

# **Crochet Patterns** FOR **DUMMIES®**

**by Susan Brittain**



Wiley Publishing, Inc.



# **Crochet Patterns** FOR **DUMMIES®**

**by Susan Brittain**



Wiley Publishing, Inc.

## Crochet Patterns For Dummies®

Published by  
**Wiley Publishing, Inc.**  
111 River St.  
Hoboken, NJ 07030-5774  
[www.wiley.com](http://www.wiley.com)

Copyright © 2007 by Wiley Publishing, Inc., Indianapolis, Indiana

Published by Wiley Publishing, Inc., Indianapolis, Indiana

Published simultaneously in Canada

No part of this publication may be reproduced, stored in a retrieval system, or transmitted in any form or by any means, electronic, mechanical, photocopying, recording, scanning, or otherwise, except as permitted under Sections 107 or 108 of the 1976 United States Copyright Act, without either the prior written permission of the Publisher, or authorization through payment of the appropriate per-copy fee to the Copyright Clearance Center, 222 Rosewood Drive, Danvers, MA 01923, 978-750-8400, fax 978-646-8600. Requests to the Publisher for permission should be addressed to the Legal Department, Wiley Publishing, Inc., 10475 Crosspoint Blvd., Indianapolis, IN 46256, 317-572-3447, fax 317-572-4355, or online at <http://www.wiley.com/go/permissions>.

**Trademarks:** Wiley, the Wiley Publishing logo, For Dummies, the Dummies Man logo, A Reference for the Rest of Us!, The Dummies Way, Dummies Daily, The Fun and Easy Way, Dummies.com and related trade dress are trademarks or registered trademarks of John Wiley & Sons, Inc. and/or its affiliates in the United States and other countries, and may not be used without written permission. All other trademarks are the property of their respective owners. Wiley Publishing, Inc., is not associated with any product or vendor mentioned in this book.

**LIMIT OF LIABILITY/DISCLAIMER OF WARRANTY: THE PUBLISHER AND THE AUTHOR MAKE NO REPRESENTATIONS OR WARRANTIES WITH RESPECT TO THE ACCURACY OR COMPLETENESS OF THE CONTENTS OF THIS WORK AND SPECIFICALLY DISCLAIM ALL WARRANTIES, INCLUDING WITHOUT LIMITATION WARRANTIES OF FITNESS FOR A PARTICULAR PURPOSE. NO WARRANTY MAY BE CREATED OR EXTENDED BY SALES OR PROMOTIONAL MATERIALS. THE ADVICE AND STRATEGIES CONTAINED HEREIN MAY NOT BE SUITABLE FOR EVERY SITUATION. THIS WORK IS SOLD WITH THE UNDERSTANDING THAT THE PUBLISHER IS NOT ENGAGED IN RENDERING LEGAL, ACCOUNTING, OR OTHER PROFESSIONAL SERVICES. IF PROFESSIONAL ASSISTANCE IS REQUIRED, THE SERVICES OF A COMPETENT PROFESSIONAL PERSON SHOULD BE SOUGHT. NEITHER THE PUBLISHER NOR THE AUTHOR SHALL BE LIABLE FOR DAMAGES ARISING HEREFROM. THE FACT THAT AN ORGANIZATION OR WEBSITE IS REFERRED TO IN THIS WORK AS A CITATION AND/OR A POTENTIAL SOURCE OF FURTHER INFORMATION DOES NOT MEAN THAT THE AUTHOR OR THE PUBLISHER ENDORSES THE INFORMATION THE ORGANIZATION OR WEBSITE MAY PROVIDE OR RECOMMENDATIONS IT MAY MAKE. FURTHER, READERS SHOULD BE AWARE THAT INTERNET WEBSITES LISTED IN THIS WORK MAY HAVE CHANGED OR DISAPPEARED BETWEEN WHEN THIS WORK WAS WRITTEN AND WHEN IT IS READ.**

For general information on our other products and services, please contact our Customer Care Department within the U.S. at 800-762-2974, outside the U.S. at 317-572-3993, or fax 317-572-4002.

For technical support, please visit [www.wiley.com/techsupport](http://www.wiley.com/techsupport).

Wiley also publishes its books in a variety of electronic formats. Some content that appears in print may not be available in electronic books.

Library of Congress Control Number: 2007931552

ISBN: 978-0-470-04555-8

Manufactured in the United States of America

10 9 8 7 6 5 4 3 2 1





## *About the Author*

**Susan Brittain's** fascination with crochet began very early, when she was 4 or 5 years old. She would watch her grandmother, who had lost her sight in midlife, spend hours crocheting beautiful afghans for friends and family, counting the stitches with her fingers. By the age of 8, Susan was crocheting her own projects, starting with simple patterns such as scarves, and then moving on to afghans, toys, and sweaters. Although her creative streak has led her to learn many different crafts, crochet has been a steady thread throughout.

Susan finally had the opportunity to combine work with pleasure, and she held the position of assistant editor for *Crochet Fantasy* magazine for a little more than two years, contributing as a designer as well. She is also the coauthor of *Crocheting For Dummies* (Wiley) and continues to design new projects for various yarn companies, as well as friends and family.



# Dedication

This book is first and foremost dedicated to my family, without whom I could never have completed this book. They gave me the time and space I needed to crochet all the designs, and then get them down on paper. My husband, Paul, and daughter, Angela, put up with boxes and bags of yarn, late meals, and piles of laundry that never seemed to quite get finished. Also, to my stepdaughters, Ashley and Sarah, who provided me with insights about what crochet projects the younger generation would like to see. Ashley even took a whole box of yarn and hooks with her when she went off to college.

Again, my gratitude goes to my family, the most important people in my life.

# Author's Acknowledgments

First of all, I'd like to thank Lindsay Lefevere at Wiley Publishing for giving me the opportunity to write another *For Dummies* book and, hopefully, expose more people to the craft of crochet. Even though crochet is "in" these days, it's a dying art, and I'd hate to see it go by the wayside. I want to thank Elizabeth Kuball, my first project editor, and Alissa Schwipps, my second and final PE, for attempting to keep me on track and for their wonderful insights, even though I probably gave both of them some sleepless nights. Thanks also go to Vicki Adang, my copy editor, for her creativity with words and making sense of my sometimes mixed-up wording.

I have to thank my husband, Paul, and my daughter, Angela, for putting up with piles of yarn, hooks, and notes scattered throughout the house and my distraction when designing a new project.

Many thanks go to Lynn Carlisle of Caron Yarns, as well as Kathleen Sams and Terri Geck at Coats & Clark for so willingly supplying me with some fabulous yarn for many of these projects.

I also send many thanks to Elizabeth, Chelsea, Savannah, and Lu for helping me out when this book was in its beginning stages.

And last but not least, thanks to the readers, who I hope get as much enjoyment from reading this book as I did from writing it.

## **Publisher's Acknowledgments**

We're proud of this book; please send us your comments through our Dummies online registration form located at [www.dummies.com/register/](http://www.dummies.com/register/).

Some of the people who helped bring this book to market include the following:

### ***Acquisitions, Editorial, and Media Development***

**Senior Project Editor:** Alissa Schwipps  
**Project Editor:** Elizabeth Kuball  
**Acquisitions Editor:** Lindsay Lefevere  
**Copy Editor:** Victoria M. Adang  
**Technical Editor:** Karen Frisa  
**Senior Editorial Manager:** Jennifer Ehrlich  
**Editorial Assistants:** Leeann Harney, Erin Calligan Mooney, Joe Niesen  
**Cover Photo:** Kreber  
**Cartoons:** Rich Tennant ([www.the5thwave.com](http://www.the5thwave.com))

### ***Composition Services***

**Project Coordinator:** Jennifer Theriot  
**Layout and Graphics:** Stacie Brooks, Carrie A. Foster, Brooke Graczyk, Denny Hager, Stephanie D. Jumper, Laura Pence, Alicia B. South, Erin Zeltner  
**Illustrations:** Many illustrations in this book are based on illustrations published in *Crochet Fantasy* magazine, an All American Crafts publication; other illustrations are based on the art of Karen Manthey.  
**Photography:** Photographs, Kreber/Mark Madden; Art Direction, Kreber/LeeAnn Kolka; Set Stylist, Kreber/Suzanne King  
**Anniversary Logo Design:** Richard Pacifico  
**Proofreaders:** Betty Kish, Susan Moritz, Christy Pingleton  
**Indexer:** Sherry Massey

---

### **Publishing and Editorial for Consumer Dummies**

**Diane Graves Steele**, Vice President and Publisher, Consumer Dummies  
**Joyce Pepple**, Acquisitions Director, Consumer Dummies  
**Kristin A. Cocks**, Product Development Director, Consumer Dummies  
**Michael Spring**, Vice President and Publisher, Travel  
**Kelly Regan**, Editorial Director, Travel

### **Publishing for Technology Dummies**

**Andy Cummings**, Vice President and Publisher, Dummies Technology/General User

### **Composition Services**

**Gerry Fahey**, Vice President of Production Services  
**Debbie Stailey**, Director of Composition Services

# Contents at a Glance

<b><i>Introduction</i></b> .....	<b>1</b>
<b><i>Part I: Reinforcing Your Crochet Foundation</i></b> .....	<b>5</b>
Chapter 1: Gearing Up and Getting Started.....	7
Chapter 2: Gauge and Garments: Sizing Facts and Figures.....	21
Chapter 3: Sum and Substance: Reading a Pattern.....	31
Chapter 4: Brushing Up on Stitch Basics.....	39
<b><i>Part II: Hook, Yarn, Action! Crocheting Simple Projects</i></b> .....	<b>53</b>
Chapter 5: Working in the First Dimension.....	55
Chapter 6: Expanding and Diminishing Dimensions: Adding Shape.....	63
Chapter 7: Going in Circles: Crocheting in the Round.....	73
Chapter 8: Coloring It In.....	85
Chapter 9: Mixing It Up: A Few Changes Make a Dramatic Difference.....	97
<b><i>Part III: Putting Your Skills to the Test</i></b> .....	<b>107</b>
Chapter 10: Seams Sew Easy: Joining Pieces Together.....	109
Chapter 11: Finding the Loopholes and Creative Combinations.....	117
Chapter 12: Sensational Sweaters.....	127
Chapter 13: Timeless Techniques: Using the Afghan Stitch and Filet Crochet.....	151
Chapter 14: Mixing Traditional Stitches with Contemporary Materials.....	169
<b><i>Part IV: The Part of Tens</i></b> .....	<b>181</b>
Chapter 15: Nearly Ten Projects That Take an Hour or So.....	183
Chapter 16: Ten-Plus Tips for Caring for Your Crochet.....	203
Chapter 17: Ten Kid-Friendly Projects.....	209
<b><i>Part V: Appendixes</i></b> .....	<b>227</b>
Appendix A: Crochet Stitches.....	229
Appendix B: Yarn Supply Sources.....	253
<b><i>Index</i></b> .....	<b>255</b>



# Table of Contents

<b><i>Introduction</i></b> .....	<b>1</b>
About This Book.....	1
Conventions Used in This Book .....	2
Foolish Assumptions .....	3
How This Book Is Organized.....	3
Part I: Reinforcing Your Crochet Foundation.....	3
Part II: Hook, Yarn, Action! Crocheting Simple Projects.....	3
Part III: Putting Your Skills to the Test.....	3
Part IV: The Part of Tens .....	4
Part V: Appendixes.....	4
Icons Used in This Book.....	4
Where to Go from Here.....	4
<b><i>Part I: Reinforcing Your Crochet Foundation</i></b> .....	<b>5</b>
<b>Chapter 1: Gearing Up and Getting Started</b> .....	<b>7</b>
Taking a Look at the Crochet Hook.....	7
Considering hook types and construction.....	8
Selecting the right size.....	9
Keeping your hooks in tiptop shape.....	10
Comprehending Yarn Complexities .....	11
A light discussion of yarn weights .....	11
Understanding what your yarn is made of.....	13
Unraveling a yarn label.....	13
A ply for a ply: Swapping yarns .....	15
Getting Your Fingers Moving .....	15
Holding the hook and yarn.....	16
Working with the hook and yarn together .....	17
It's in the Bag: Completing Your Crochet Kit .....	18
<b>Chapter 2: Gauge and Garments: Sizing Facts and Figures</b> .....	<b>21</b>
Practicing with a Gauge Swatch .....	21
Making a swatch .....	22
Determining whether you're on the right track .....	22
Making adjustments.....	24
Sizing Your Garment .....	24
Tale of the tape: Taking accurate measurements.....	24
Fit to be sized: Adjusting the fit.....	26
Picking the Right Pattern Size .....	27
<b>Chapter 3: Sum and Substance: Reading a Pattern</b> .....	<b>31</b>
Interpreting the Written Instructions .....	31
Understanding the abbreviations.....	32
Taking note of common terms .....	33
Deciphering the symbols .....	33
Decoding the Diagram .....	36



<b>Chapter 4: Brushing Up on Stitch Basics .....</b>	<b>39</b>
Keeping You in Stitches .....	39
Refreshing the fundamentals .....	39
Constructing combinations .....	41
Change Is Good: Adding New Yarn .....	42
Making the switch at the beginning or end: It's all the same .....	42
Midstream changes .....	43
Hold on tight! Carrying your yarn .....	44
Weave it to the end .....	46
The Ins and Outs of Increasing and Decreasing Stitches .....	46
Expanding rows by adding stitches .....	46
Shortening your rows with dwindling numbers .....	47
You'll Come Around: Crocheting in Circles .....	49
Crafting the center ring .....	50
Making the first round .....	50
Joining ends .....	51
Branching out .....	51
Just keep going: Spirals .....	52
Creating shapes .....	52

***Part II: Hook, Yarn, Action! Crocheting Simple Projects.....53***

<b>Chapter 5: Working in the First Dimension .....</b>	<b>55</b>
Practical Potholders .....	55
Materials and vital statistics .....	56
Directions .....	57
Variation: Doubling the thickness .....	57
Variation: Pumping up the size .....	57
Handy Headbands .....	57
Materials and vital statistics .....	58
Directions .....	59
A Smart Scarf .....	59
Materials and vital statistics .....	60
Directions .....	60
Wooly Warmer Afghan .....	60
Materials and vital statistics .....	61
Directions .....	62
Variation: Supersize it! .....	62
Variation: Trying a different yarn .....	62
<b>Chapter 6: Expanding and Diminishing Dimensions: Adding Shape .....</b>	<b>63</b>
Beaded-Fringe Belt .....	63
Materials and vital statistics .....	64
Directions .....	65
Variation: Adding some color or a jingle .....	66
Shades-of-Gray Shawl .....	66
Materials and vital statistics .....	67
Directions .....	67
Festive Diamond-Shaped Table Runner .....	68
Materials and vital statistics .....	68
Directions .....	69
Variation: Giving it some shine, or adding a detail .....	69
Curlicue Scarf .....	70
Materials and vital statistics .....	70
Directions .....	71
Variation: Shrinking the scarf.....	71



<b>Chapter 7: Going in Circles: Crocheting in the Round .....</b>	<b>73</b>
Flirty Denim Skirt .....	73
Materials and vital statistics .....	74
Directions .....	75
Coffee Suede Beret .....	76
Materials and vital statistics .....	77
Directions .....	77
Variation: Add a different color .....	79
Red Velvet Crusher Hat .....	80
Materials and vital statistics .....	80
Directions .....	81
Bella Drawstring Bag .....	82
Materials and vital statistics .....	82
Directions .....	83
Variation: Making a sturdier bag .....	84
<b>Chapter 8: Coloring It In .....</b>	<b>85</b>
A Scarf of a Different Color .....	85
Materials and vital statistics .....	86
Directions .....	87
Denim Cloche .....	87
Materials and vital statistics .....	88
Directions .....	89
Wavy Chevron Throw .....	90
Materials and vital statistics .....	91
Directions .....	91
Variation: Highlight the stitches, not the colors .....	92
Cozy Chenille Throw Rug .....	92
Materials and vital statistics .....	93
Directions .....	93
Variation: Size it to fit just right .....	95
Variation: Fringe it! .....	95
<b>Chapter 9: Mixing It Up: A Few Changes Make a Dramatic Difference .....</b>	<b>97</b>
Beads-'n'-Bows Belt .....	98
Materials and vital statistics .....	98
Directions .....	99
Ruffles-'n'-Bows Scarf .....	100
Materials and vital statistics .....	100
Directions .....	101
Child's Rolled-Brim Hat .....	101
Materials and vital statistics .....	102
Directions .....	102
Adult's Rolled-Brim Hat .....	103
Materials and vital statistics .....	104
Directions .....	104
<b>Part III: Putting Your Skills to the Test .....</b>	<b>107</b>
<b>Chapter 10: Seams Sew Easy: Joining Pieces Together .....</b>	<b>109</b>
Furry Boa Pillow .....	109
Materials and vital statistics .....	110
Directions .....	110

Flower-Power Belt .....	111
Materials and vital statistics .....	112
Directions .....	112
Variation: Choosing hues that fit your style .....	113
Southwest Vest .....	114
Materials and vital statistics .....	114
Directions .....	115
Variation: Belt it! .....	116
<b>Chapter 11: Finding the Loopholes and Creative Combinations .....</b>	<b>117</b>
Elegant Evening Wrap .....	117
Materials and vital statistics .....	118
Directions .....	118
Double-Crossing Belt .....	119
Materials and vital statistics .....	120
Directions .....	121
Love Those Loops Scarf .....	121
New skill: The loop stitch .....	122
Materials and vital statistics .....	123
Directions .....	123
Variation: Adding more loops .....	124
Variation: Fashioning a furry look .....	124
Variation: Swapping yarns .....	124
Geometric Wrap .....	124
Materials and vital statistics .....	125
Directions .....	126
Variation: Why knot add beads? .....	126
<b>Chapter 12: Sensational Sweaters .....</b>	<b>127</b>
Vertical Stripes Tunic .....	127
Materials and vital statistics .....	128
Directions .....	129
Lacy Bolero .....	133
Materials and vital statistics .....	134
Directions .....	134
Springtime Pullover .....	138
Materials and vital statistics .....	138
Directions .....	139
Shell Stitch Tank Top .....	141
Materials and vital statistics .....	142
Directions .....	143
Fur-Trimmed Jacket .....	145
Materials and vital statistics .....	146
Directions .....	147
<b>Chapter 13: Timeless Techniques: Using the Afghan Stitch and Filet Crochet .....</b>	<b>151</b>
Afghan Stitch Baby Blanket .....	151
New skill: The afghan stitch .....	152
Materials and vital statistics .....	154
Directions .....	154
Variation: Making a bigger blankie .....	155
Variation: Picking a new color palette .....	155
Tunisian Stitch Tote Bag .....	155
New skill: The Tunisian knit stitch .....	156
Materials and vital statistics .....	157
Directions .....	157

Love-to-Read Bookmark .....	158
New skill: Basic filet crochet stitches .....	158
Materials and vital statistics .....	161
Directions .....	161
Heartland Window Valance.....	163
New skill: Fancy filet crochet stitches .....	163
Materials and vital statistics .....	166
Directions .....	167
Variation: Using the pattern to create edging.....	168
<b>Chapter 14: Mixing Traditional Stitches with Contemporary Materials .....</b>	<b>169</b>
Not Your Granny's Scarf .....	169
Materials and vital statistics .....	170
Directions .....	171
Variation: Making a cozy afghan .....	171
Shells and Lace Pillowcase Edging .....	172
Materials and vital statistics .....	173
Directions .....	173
Honey, I Shrank My Bag.....	174
Materials and vital statistics .....	175
Directions .....	175
Variation: Felting? Fuhgeddaboutit! .....	176
Hemp Basket .....	176
Materials and vital statistics .....	177
Directions .....	177
Variation: Making the basket just the right size .....	178
Variation: Using different sizes of hemp cord.....	178
Wire-'n'-Beads Necklace .....	178
Materials and vital statistics .....	179
Directions .....	179
Variation: Dressing up the look .....	180
Variation: Complementing the necklace.....	180
<b>Part IV: The Part of Tens .....</b>	<b>181</b>
<b>Chapter 15: Nearly Ten Projects That Take an Hour or So .....</b>	<b>183</b>
Lacy Bookmark.....	183
Materials and vital statistics .....	183
Directions .....	184
Geometric Coaster Set.....	185
Materials and vital statistics .....	185
Directions .....	186
Variation: Creating coordinating table accessories .....	189
Fun Fur Scrunchies .....	189
Materials and vital statistics .....	190
Directions .....	190
Friendship Bracelet.....	190
Materials and vital statistics .....	191
Directions .....	191
Variation: Dressing the bracelet up with ribbon .....	192
Variation: Adding some width.....	192
Velvet Roses .....	192
Materials and vital statistics .....	193
Directions .....	193
Pocket Patches .....	194
Materials and vital statistics .....	195
Directions .....	195

Stemmed-Glass Markers .....	197
Materials and vital statistics .....	198
Directions .....	198
Variation: Making a marker set for every occasion .....	199
Must-See Fur Frame .....	199
Materials and vital statistics .....	199
Directions .....	200
Standout Luggage Tags .....	200
Materials and vital statistics .....	201
Directions .....	201

## **Chapter 16: Ten-Plus Tips for Caring for Your Crochet .....203**

Be a Pack Rat: Save the Labels .....	203
Show Your Care: Attach Your Own Care Labels .....	204
Forget Dishpan Hands. Get Afghan Hands! .....	205
Blocking for a Better Shape .....	205
Take It to the Cleaners .....	206
Get a Load of This: Machine Washing .....	206
Let It Go for a Spin: Machine Drying .....	206
Iron It — but Only If You Must .....	207
Put Those Hangers Away! .....	207
Dazzling Displays and Safe Storage .....	207
Get Rid of Those Pesky Pills .....	208

## **Chapter 17: Ten Kid-Friendly Projects .....209**

Blue Note Scarf .....	209
Materials and vital statistics .....	210
Directions .....	210
Wear Your Heart Pin .....	210
Materials and vital statistics .....	211
Directions .....	211
MP3 Player Cover .....	213
Materials and vital statistics .....	213
Directions .....	214
Beadies Can-Cozy .....	215
Materials and vital statistics .....	216
Directions .....	216
Page Runner .....	217
Materials and vital statistics .....	217
Directions .....	218
Camouflage Belt .....	218
Materials and vital statistics .....	219
Directions .....	219
Chocolate Lace Headband .....	220
Materials and vital statistics .....	221
Directions .....	221
Chain-Link Bracelet .....	221
Materials and vital statistics .....	222
Directions .....	222
Variation: Making matching pieces .....	223
Think Pink Pocket Purse .....	223
Materials and vital statistics .....	223
Directions .....	224
Variation: Stitching a small handbag .....	224
Beaded Anklet .....	225
Materials and vital statistics .....	226
Directions .....	226

<b>Part V: Appendixes</b> .....	<b>227</b>
<b>Appendix A: Crochet Stitches</b> .....	<b>229</b>
Slipknot.....	229
Chain Stitch (ch) .....	230
Slip Stitch (sl st) .....	231
Single Crochet Stitch (sc) .....	232
Double Crochet Stitch (dc).....	232
Triple Crochet Stitch (tr) .....	233
Double Triple Crochet (dtr).....	234
Half Double Crochet Stitch (hdc).....	235
Decrease 1 Single Crochet Stitch (dec 1 sc) .....	236
Decrease 1 Double Crochet Stitch (dec 1 dc).....	237
V-stitch .....	238
Crossed Double Crochet Stitch .....	238
Shell Stitch .....	239
Picot .....	239
Cluster Stitch .....	240
Reverse Single Crochet Stitch (reverse sc) .....	241
Puff Stitch .....	242
Popcorn Stitch (pop or pc).....	242
Bobble Stitch .....	244
Front Post Double Crochet (FPdc).....	244
Back Post Double Crochet Stitch (BPdc) .....	246
Long (Spike) Stitch.....	247
Fringe .....	248
Tassels .....	249
Whipstitch.....	250
Blanket Stitch.....	250
<b>Appendix B: Yarn Supply Sources</b> .....	<b>253</b>
<b>Index</b> .....	<b>255</b>



# Introduction

---

There's nothing like being able to sit down in a favorite chair for a while to catch up on some much needed down time, whether it's in the evening after the dinner dishes are done or on a rainy afternoon. If you're anything like me, though, you find it hard to just sit. This is when I like to get my crocheting out and sit and relax, but still be creative at the same time.

As with any new skill, practice makes perfect. Even after 30-plus years of working with a hook and yarn, I still learn new techniques and new ways to do old things. Mastering the basics is, of course, essential, and even if you've been crocheting for a while, it never hurts to review skills that may be a little rusty.

*Crochet Patterns For Dummies* was written so you can practice and enhance your skills in this time-honored craft, while at the same time create designs that are both useful and fashionable.

## About This Book

The craft of crochet has been around for hundreds of years, originally developed out of necessity, and then continued throughout the ages because of the beautiful designs that can be created. I can't even begin to count the variations of stitches that can be crocheted, but one thing I can tell you is that they all begin with the basics. For that reason, I give you projects in this book that allow you to develop a strong foundation of the most commonly used stitches and stitch patterns.

Patterns' skill levels are categorized as Beginner, Easy, Intermediate, or Advanced, and some pattern books note the skill level using one of the following symbols:

 Beginner

 Easy

 Intermediate

 Experienced

I don't include the symbols in this book because most of the patterns fall into the Beginner and Easy categories. I note which patterns are more advanced in the pattern introductions. Each chapter is organized so the patterns graduate from the least to the most complicated, so you can pick and choose where you want to begin.

Each part of this book focuses on a different aspect of crochet, and the parts are further broken down into chapters pertaining to specific information, such as

- ✓ Hook and yarn information, and how to choose the right materials
- ✓ Deciphering crochet lingo, reading a pattern, and understanding garment sizing

- ✔ A review of the basic stitches and stitch combinations, with a concise appendix containing step-by-step instructions for working these stitches
- ✔ Loads of patterns separated into chapters for specific skills used

To give you an idea of what the projects look like when they're finished, I include photos:

- ✔ Each set of project instructions within the chapter includes a photo of the completed item.
- ✔ In the center of the book, you can find color photos of the projects. These photos also give you a better idea about the yarn colors I chose. (Of course, if you're not crazy about the yarn I used, you can always branch out on your own and choose colors that are more suited to your taste.)

Some instructions also include illustrations that show you stitch diagrams or project dimensions. Some things are easier to visualize than read about, and these illustrations are meant to show you how stitches or sizes relate.

Some projects include a "Variation" section after the basic instructions. This can be as simple as how to substitute materials, or it can give you ideas about creating a whole new project from the original pattern. Read these sections even if you don't want to employ them. They can expand your knowledge about crochet and how you can adapt designs and patterns.

The best thing about this book is that you don't have to read it cover to cover. You choose where to start. If something looks interesting, go ahead and flip to that chapter. If you need a refresher on a certain skill used, go ahead and flip back, make a practice swatch, and then continue on with the project.

## *Conventions Used in This Book*

The following conventions are used throughout the text to make the patterns consistent and easy to understand:

- ✔ New terms appear in *italic* and are closely followed by an easy-to-understand definition.
- ✔ **Bold** is used to highlight the action parts of numbered steps and for keywords in bulleted lists.
- ✔ When you see a set of bulleted (•) instructions in this book, work the stitches through once, and then go back and repeat them the number of times indicated.
- ✔ If a new skill is introduced that is not included elsewhere in the book, you'll find it listed within that particular pattern under the heading "New skills." In that section, you'll find step-by-step instructions on how to work that particular stitch.
- ✔ The specific part of an illustration that relates to the step you're working on is shaded dark gray. For example, if you're inserting your hook into a certain stitch, only that stitch is shaded so you can clearly see where to go.
- ✔ The patterns included in this book are all written in typical crochet fashion, as you'd see in any publication. Crochet has a language all its own, most of it abbreviated. To brush up on the lingo, see Chapter 4.



## ***Foolish Assumptions***

My greatest hope is that, by picking up this book, you are looking to further develop the crochet skills that you already possess. If you have a working knowledge of the basics and are ready to take your skills to the next level, then you've come to the right place. This book does contain a little bit of very basic, beginner-level information to help jog your memory, but you should have at least some prior experience.

If you're looking to learn to crochet from the start, then look around the bookshelves for *Crocheting For Dummies*, the companion book to this one. In that book, you'll find in-depth information about crochet from start to finish. If you're feeling really adventurous, pick up both books so you'll have a complete set.

## ***How This Book Is Organized***

This book is divided into five easily identifiable parts, with a total of 17 chapters and two appendixes. Any brand-new stitches that are introduced within a particular chapter are illustrated in the "New skills" section. If at any point it seems that you need specific knowledge about a concept, I'll point you in the right direction.

### ***Part I: Reinforcing Your Crochet Foundation***

This part contains all the reference material you need to crochet your way through the rest of the book. It starts off with choosing the right hook and yarn, and then moves on to figuring out gauge. Information about reading patterns, sizing garments, and understanding stitches and their relationships to each other is included in this section. And last, but not least, you can refresh your memory about how to change colors correctly, increasing and decreasing stitches, and crocheting in a circle.

### ***Part II: Hook, Yarn, Action! Crocheting Simple Projects***

Part II has five chapters packed full of patterns designed to get your fingers moving. Each chapter focuses on a different aspect of the basic skills. You can choose a project in which you concentrate on crocheting your stitches evenly, or one that has you shaping the design through increases and decreases. You can make great accessories while crocheting in the round, or you can crochet multicolored patterns designed to get you into the color-changing mode.

### ***Part III: Putting Your Skills to the Test***

Ready to take your skills a step further? The patterns in this part of the book combine all of the basics and more. I include a whole bunch of sweater designs, as well as more home décor and accessories. You'll use some slightly more advanced techniques, as well as see what it's like to work with unconventional materials such as hemp and wire.

## Part IV: The Part of Tens

Not to be outdone, Part IV has loads of patterns as well. Included are quick 'n' easy designs that are great for when you need a creative fix. I also came up with a whole bunch of designs with the younger set in mind. I hope these patterns get them crocheting, but they're great for you to make as gifts for tweens and teens as well. This part also contains information on caring for your work after it's done.

## Part V: Appendixes

When you get stuck, turn to this part for a little help. Appendix A walks you through how to do basic and not-so-basic crochet stitches. Appendix B provides yarn companies' names and contact info that you can use when you can't find the yarn you want in your neighborhood craft store.

## Icons Used in This Book



To make this book easier to read and simpler to use, I include some icons that can help you find and fathom key ideas and information that are worth taking a second glance at.

This icon appears any time I provide information that can make your work a bit easier or show you a trick that experienced crocheters have developed over the years.



Any time you see this icon, you should know that the information that follows is important. It highlights different points in the skills or pattern that you should remember.



When you see this icon, be sure to read carefully the information that follows. It can help you avoid common mistakes and pitfalls that can lead to a disastrous finished design.

## Where to Go from Here

The beauty of this book is that you can start anywhere you want. If it's been a while since you've crocheted, or if you're still a relative beginner, then by all means start at the beginning. If you're ready to jump right in, browse through the project chapters or take a look at the color insert and choose one that looks like fun. Chapter 12 is all about sweaters. Chapter 15 has a bunch of patterns that you can make in an hour or so. And I've scattered accessories and home décor items throughout the project chapters.

Remember, though, that you can always seek additional, in-depth information in the companion book, *Crocheting For Dummies*. It provides detailed explanations on everything provided in this book.

# Part I

# Reinforcing Your Crochet Foundation

The 5<sup>th</sup> Wave

By Rich Tennant



"That one? That's your P-100 industrial hook, used mostly for crocheting chainlink fences, mesh grill tops, that sort of thing."

## *In this part . . .*

**T**aking another step into the world of crochet is exciting. Gaining more experience will help you expand your skills and knowledge of this time-honored craft. Even the best of us, though, need some refresher information now and then.

This part of the book provides some basic information that will never be obsolete. First and foremost, I explain how to choose the right materials, from hooks to yarn. Moving on, you can refresh your knowledge of the all-important concept of gauge, from how to calculate it to the impact it can have on the final outcome of your finished piece. You'll also find some invaluable information about reading patterns and deciphering the lingo associated with crochet. And last but not least, I include a review of the stitches you'll find throughout the book.

Take some time to glance through this part, and know that it's here as a reference for you as you crochet.

# Chapter 1

## Gearing Up and Getting Started

### *In This Chapter*

- ▶ Deciphering the difference between hooks
- ▶ Unraveling yarn mysteries
- ▶ Collecting other crochet accouterments
- ▶ Holding the yarn and hook

**W**hen embarking on a new project, gathering the necessary supplies is a must before you can even think about starting. To begin a new crochet design, you need a hook and some yarn, and you're all set to go.

Like most crafts, even those with the simplest needs, there are variations in the tools used. This chapter covers the differences between the various types of hooks available and when it's appropriate to use each type. Additionally, yarns are now available in a huge array of colors, textures, weights, and compositions. After you have a basic understanding of the more common yarns available, you will have an easier time choosing which yarn is best for your project.

And if you want to brush up on the best way to hold your hook and yarn, you'll find that information in this chapter, too.

### *Taking a Look at the Crochet Hook*

A hook is one of two essentials for crocheting. (The other being yarn, of course. More on yarn later.) Choosing the proper crochet hook is essential to your comfort and the outcome of your design.

Crochet hooks are all basically the same in design. They each have a point, throat, shaft, and handle, and most (except the largest sizes) have a thumb rest (see Figure 1-1).

**Figure 1-1:**  
The anatomy of a crochet hook.

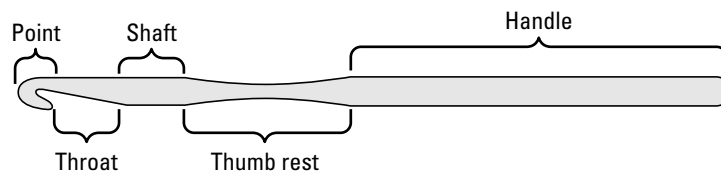

There are, however, subtle differences in the hook's shape. Some hooks have rounded points, which generally work easiest with thicker yarns, while others have sharper points that are ideal for thin yarns, wire, and other detail work. Some hooks have distinct, cutout throats that help to keep the yarn in place on the hook. Others have a smoother, more rounded throat, which enables you to work through stitches very quickly. As for which features to look for on your hook, it's just a matter of preference. Practice with every type to see which features you prefer. Sometimes it's just a matter of selecting the hook you like best for a particular yarn, stitch, or project.

## *Considering hook types and construction*

Crochet hooks are typically divided into two primary categories, based on the diameter of the hook shaft. You can find hooks ranging from a fraction of a millimeter in diameter up to hooks larger than your finger. Depending on the size, a hook can be sorted into two primary categories:

- ✔ **Standard:** These hooks are typically used when crocheting with yarn, and they range from 2mm up to 20mm in diameter.
- ✔ **Steel:** These hooks are smaller and generally used when working with crochet thread, size 10 and smaller.

Steel hooks are made of, well, steel. But standard hooks can be made of different materials including aluminum, plastic, and even wood. The following list helps you weigh the pros and cons of each material:

- ✔ **Aluminum:** These hooks are lightweight and smooth, helping you work with the yarn quickly and without catching. Aluminum hooks are some of the easiest to find and are often coated in a spectrum of colors.
- ✔ **Plastic:** These hooks are also lightweight, but they can feel sticky to work with. While inexpensive, some crocheters feel the grippy plastic slows them down.
- ✔ **Wood:** Crochet hooks can be made out of hard woods such as ebony, rosewood, and oak with fine woodworking techniques. These hooks are beautiful to look at, and, when made properly, can be as pleasant to use as your favorite aluminum workhorse. You also can likely find inexpensive bamboo hooks, even in your local megastore. These also have a bit more “grip” than aluminum, but many crafters enjoy how they stay warm in your hands.

For most of your crochet projects, the hook you'll require is generally 5 to 6 inches long and falls into one of the above categories. Don't be surprised to read about — or see in the store — other hook-ended tools, including

- ✔ **Afghan hooks:** These hooks range from 12 to 16 inches in length, with a hook at one end and a knob at the other. These hooks are used for afghan or Tunisian stitches that require you to keep more than one loop on the hook shaft. For examples of some of these projects, check out Chapter 13.
- ✔ **Double ended crochet hooks:** Also long like afghan hooks, these tools have a hook at each end. They are used for something called *double ended crochet*, which makes a thick and reversible fabric.

## Selecting the right size

There are two separate sizing categories when it comes to hooks, one for standard hooks and one for steel hooks. Knowing which is which is invaluable. The pattern that you're working from will give you the size hook used to crochet the original design. This is especially important because not only is it the proper size for the type of yarn used, but it also determines the size of the stitch it creates, which determines the gauge (see Chapter 2 for detailed gauge info). The gauge, in turn, determines the final size of the design.

Hooks come in a wide range of sizes (see Figure 1-2) and are labeled accordingly (most standard hooks are labeled with both the U.S. and Continental sizes). The labels are sometimes embossed on the side of the shaft. On other hooks, you may see a raised letter or number on the round end of the shaft. Hooks with padded or "comfort" grips may display this information on the grip.

In the U.S. and Canada, standard hooks are labeled using letters, with B on the small end and S on the large end. In the U.S. and Canada, steel hooks are labeled using numbers. These hooks range from the smallest fraction of a millimeter to about 2 millimeters in diameter. Table 1-1 gives the most common sizes for steel crochet hooks and standard crochet hooks. Take note that the U.S. and U.K. sizes for steel hooks are the opposite of what you'd expect — the larger the number, the smaller the hook. And the U.K. sizes for standard hooks are a bit backwards, too — the smaller the number, the larger the hook.

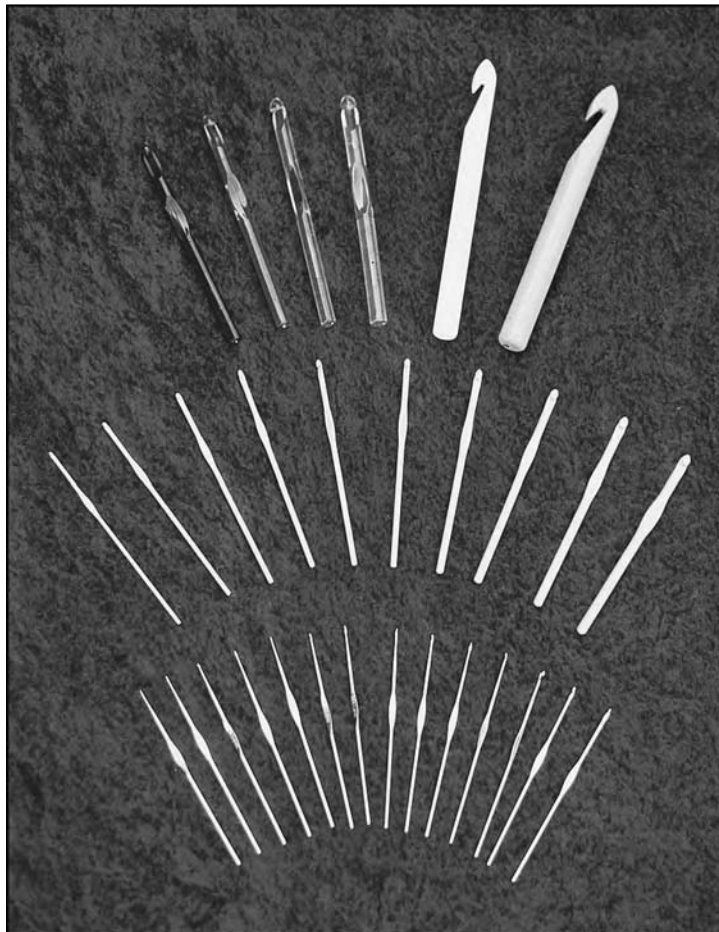

**Figure 1-2:**  
The wide  
array of  
sizes for  
both  
standard  
and steel  
hooks.

<b>Table 1-1 Common Crochet Hook Sizes</b>		
<b><i>Steel Crochet Hooks</i></b>		
<b><i>U.S. (American)</i></b>	<b><i>Continental (Metric)</i></b>	<b><i>U.K. (English)</i></b>
6	1.8mm	3½
7	1.65mm	4
8	1.5mm	4½
9	1.4mm	5
10	1.3mm	5½
<b><i>Standard Crochet Hooks</i></b>		
<b><i>U.S. (American)</i></b>	<b><i>Continental (Metric)</i></b>	<b><i>U.K. (English)</i></b>
E-4	3½mm	9
F-5	3¾mm	(no equivalent)
G-6	4mm	8
G-7	4½mm	7
H-8	5mm	6
I-9	5½mm	5
J-10	6mm	4
K-10½	6½mm	3

## *Keeping your hooks in tiptop shape*

Over time, you'll build up quite a collection of hooks. And although hooks aren't expensive, you don't want to have to run out and buy the same hook over and over again because you damaged or lost the first one you bought in that size. Follow this advice to keep your hooks like new and safe:

- ✓ **Cleaning:** You may not think this is too important or wonder how the hooks get dirty. But if you stop to think about it, it becomes obvious. The hook is tucked in your hand or between your fingers for each and every stitch you work, and your hands have natural oils that protect the skin. Over time, these oils build up on your hook and may rub off on your yarn.
  - For your steel hooks, a good soaking in rubbing alcohol does the trick. Follow the bath by rubbing down the hook with a clean, soft cloth.
  - Aluminum and plastic hooks benefit from a thorough washing with a mild detergent. Dry completely before storage.
  - Wood hooks are a bit trickier to clean. Although most have been lacquered or coated to resist splintering, it's not advisable to soak or scrub the hook. Instead, use a damp cloth to wipe clean. Be sure to dry it with a clean towel almost immediately.





✓ **Storing:** Proper storage ensures that the hook you need for your next project is ready, willing, and able for work when you are. Invest in a case specially made to store hooks. They are readily available at craft and yarn shops. If you can't find one, or don't want one, roll your hooks in a piece of felt, keeping them separated.

Throwing your hooks in a bag or box can cause them to bang together, creating pits, which in turn can cause snags in the yarn as you work. Plastic hooks can bend and become warped as well as pit.

## Comprehending Yarn Complexities

When I first started crocheting, choosing yarn wasn't much more difficult than deciding which color to use. Aside from crochet thread, there were only a couple different sizes, and no interesting textures. Colors were either solid or *variegated* (meaning they contain multiple colors). As I'm sure you've seen, that's not the case today. Just walk into the yarn aisle of your favorite craft store or any yarn shop, and you can literally spend hours sorting through the variety of colors and textures available.

Most of the time, you'll decide to make a particular project based on how the item looks; you like the overall design and the material it's made with. Although pictures are nice, you can't always see all the details, and understanding what type of yarn is used to craft the project can go a long way in determining if you'll really like the finished design. The important points to note about the materials can be found on the yarn label. Pay close attention to yarn size or weight and yarn content, but don't be afraid to mix it up. The "A ply for a ply: Swapping yarns" section tells you how.

### *A light discussion of yarn weights*

When the word *weight* is used in relation to yarn, it generally means the thickness of the yarn. The thicker the yarn, the larger the stitches you'll be able to create.

Yarns are labeled with any of about a dozen names that all describe the weight of the yarn. You may see the words "worsted," "aran," "double knitting," "sport," or "chunky." All of these words (and several more) roughly correspond to the thickness of the yarns. So, if a pattern asks for a chunky yarn, you can't really use a substantially thinner sport weight and expect the same results. But you can expect all worsted-weight yarns to crochet to more or less the same fabric. These yarn weights correspond to the gauge, or number of stitches per inch, that you can expect to obtain while crocheting.

Figure 1-3 compares some of the more common weights and textures, but keep in mind that the photo is far from inclusive.

Over the course of the last few years, the yarn industry has been making inroads into standardizing yarn weights. This is really a wonderful effort because one particular weight of yarn can be called several different names (for example, yarns categorized as worsted, afghan, and aran all have the same weight). Figure 1-4 shows the new symbols in use and the weights (or sizes) of yarn they represent.

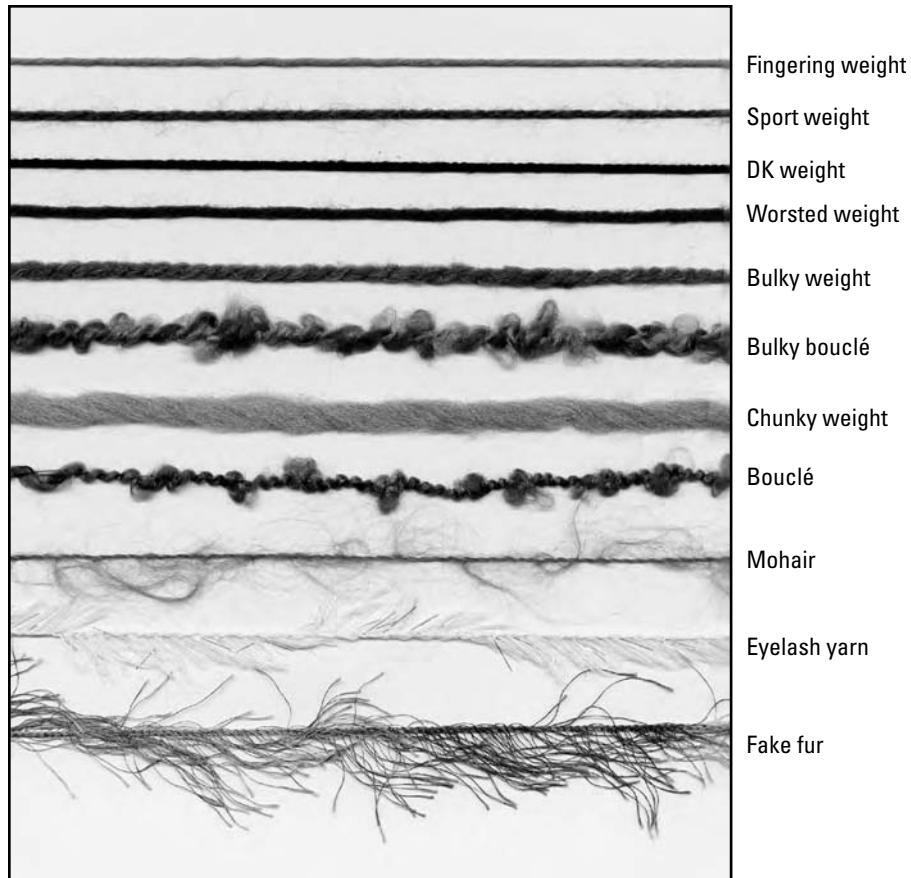

**Figure 1-3:** Comparison of commonly used yarn weights.

Yarn Weight, Symbol & Category Names	 1 SUPER FINE	 2 FINE	 3 LIGHT	 4 MEDIUM	 5 BULKY	 6 SUPER BULKY
Type of Yarns in Category	Sock, Fingering, Baby	Sport, Baby	Double Knitting, Light Worsted	Worsted, Afghan, Aran	Chunky, Craft, Rug	Bulky, Roving

**Figure 1-4:** Standard yarn-weight system.

*Courtesy of Craft Yarn Council of America*

So if you really love a project but don't like the suggested yarn, you can use the yarn-weight symbol to find another yarn of the same weight that will work just as well for the item. If the yarn or the pattern you like doesn't use a standard yarn-weight symbol, you can still substitute effectively. Just look at the gauge information provided on the ball band (or yarn label) and pattern and make sure they match. (Chapter 2 goes into more detail on the concept of gauge.)

## Understanding what your yarn is made of

Something to keep in mind when working with yarn is its composition. Do you prefer manmade materials, or are you a natural person? Yarns are readily available in both, and sometimes it comes down to your favorite choice. Garments are especially nice if they're made of natural fibers such as wool, silk, or cotton, while items such as afghans lend themselves to synthetic fibers, such as acrylic, mainly because of the reasonable cost and ease of care.

When beginning to crochet, most people find it easiest to learn on a smooth wool or wool/acrylic blend. Although pure acrylic yarns are often the most inexpensive and easiest to find, they don't have much elasticity. When you're just starting out, this means your stitches may look more uneven than in a wool or wool-blend yarn. Slippery fibers, such as cotton or silk, create beautiful fabric but can be tough for an inexperienced crocheter to keep on the hook. After a little experience, you'll be able to crochet wonderfully with any yarn.

As far as price is concerned, on the cheaper end of the scale are usually pure acrylic and other manmade yarns. On the high end are cashmere, silk, and other luxury fibers. Workhorse wools, cottons, and blends of more than one fiber type fall in the middle of the spectrum.

When looking for yarns of different fiber types, be aware that every store carries a different range of products. Although you may have a great variety of budget acrylic yarns at your local megastore, you may have to go to specialty yarn shops for pure silks and wools. But this is changing. It's now not uncommon to find great quality natural fibers in some of the same stores that were long known for carrying only synthetics.

Most patterns, however, specify a particular yarn because it makes the design what it is, so keep that in mind if you substitute a different brand or type of yarn. No matter what you do, that fluffy wool yarn won't look the same as a shiny cotton when crocheted.

## Unraveling a yarn label

Whether packaged in a neat little ball, a long, log-like pull-skein, or a twisted skein or hank, all yarns come with a label that gives you invaluable information about its possible use with your project. As shown in Figure 1-5, all the information necessary to choose the right yarn can be found in one small space.

**Figure 1-5:**  
Essential  
information  
located on a  
yarn label.

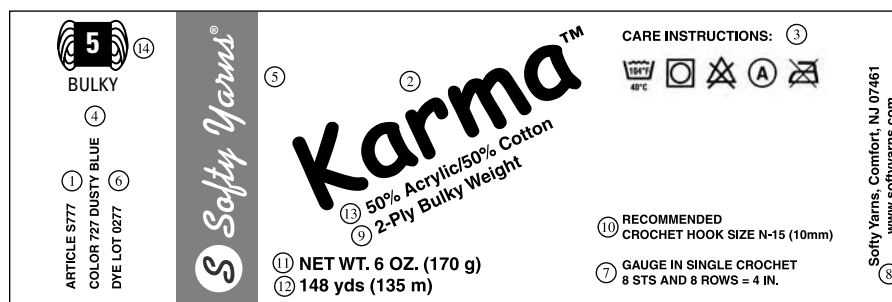

Yarn labels typically include most, if not all of the following information:

- 1. Article number:** This is a code that the manufacturer uses to keep track of different products, and you won't always find an article number on a ball of yarn.
- 2. Brand name:** This is the name of the yarn. For example, "Silk Purse," "Baby Soft," or "Regia 4ply."
- 3. Care instructions:** Is easy care important to the project? If so, look for yarns labeled "Superwash" or that give care instructions that allow for machine wash and dry. More delicate yarns will tell you to hand wash or dry clean to prevent shrinking.
- 4. Color name and number:** A particular yarn color is given a name or a number (or sometimes both) by the manufacturer.
- 5. Company name and logo:** The manufacturer's name and logo will be prominently displayed on the label. Note that this should not be confused with the brand name of the yarn.
- 6. Dye lot number:** Yarns that have been machine or hand dyed will include an identifying number that relates to the batch, or *lot*, in which the yarn was dyed. When a project requires more than one skein or ball of yarn, be sure to purchase yarn from the same dye lot if you want the colors to match perfectly. Yarns from different dye lots can have subtle (or not-so-subtle) variations in color that could have you seeing stripes.
- 7. Gauge:** The suggested *gauge*, or number of stitches that fit in 4 inches, is often given on the label. Sometimes only a gauge in knitting is provided. Knitted gauge is given generically, such as "20 sts = 4 inches," and does not relate to the crochet gauge at all. More often than not, though, both knit and crochet gauges are given. For crochet, look for any crochet stitch abbreviation, usually "sc" (single crochet), or a small picture of a crochet hook next to a number. For example, "12 sc = 4 inches" is an example of crochet gauge.
- 8. Manufacturer's address:** The yarn manufacturer's location is sometimes provided. It can be helpful if you need to find another source for its yarns. Increasingly, the manufacturer's Web site is being added, which can be a great resource for yarn information and sometimes free patterns.
- 9. Ply:** Occasionally, a yarn label will provide *ply information*, such as 2 ply, 4 ply, or 12 ply, which means the number of strands that are twisted together to create the yarn. The number of plies does not correspond to the crochet gauge or the yarn weight. For example, it's possible to have a super-thick 2-ply or a super-thin 12-ply yarn, or vice versa.
- 10. Recommended hook size:** When a crocheted gauge is given, a recommended hook size to obtain that gauge is also provided. You may need a different size hook to obtain the same gauge as the ball band or for the gauge provided in the pattern. (Read Chapter 2 for more details on gauge.)
- 11. Weight:** The physical weight of the ball or skein of yarn will be listed. This may be in grams or ounces or both, depending on the country of origin.
- 12. Yardage:** The length of the yarn will be given in yards and/or meters depending on the country of origin. Be sure to buy enough yards for your project. Don't be tempted to buy by weight only. Different types of yarn, even at the same thickness, contain vastly different yards per gram or ounce, and you don't want to run short.
- 13. Fiber content:** By law, every commercially available yarn must include a detailed description of its fiber content. For example, you may see "100% merino wool" or blends such as "65% acrylic, 15% nylon, 15% elasten, 5% cotton."
- 14. Yarn-weight symbol:** Many yarn companies are beginning to include this symbol, handy for yarn substitution, provided your pattern also includes the symbol. (See the earlier section, "A light discussion of yarn weights," for more on these symbols.)

## *A ply for a ply: Swapping yarns*

Most patterns will tell you specifically which yarn to use for best results, but never forget that you have the option to substitute another yarn. Let your imagination go. With all the choices available, there's no reason not to make some changes to suit your own taste. (Appendix B contains a list of yarn companies and their Web addresses for your browsing pleasure.)

Changing yarn can be as simple as choosing a different color of the same yarn used in the original pattern, or much more complex by picking a different yarn altogether. If you prefer wool and the pattern uses an acrylic yarn, you can look for a substitute. Just be sure to keep the following in mind:

- ✓ **Weight (or thickness):** If the pattern calls for a worsted- (or medium-) weight yarn, stick to that. Using a chunky-weight yarn (yarn that is heavier than worsted-weight) or sport-weight yarn (yarn that is lighter) will alter your results dramatically.

This is where the yarn-weight symbols come in handy. If your pattern and the yarn you want both use the symbols, be sure they match. Otherwise, check the gauge section of the yarn label and pattern to be sure the yarns crochet similarly. If your pattern gives only crocheted gauge, and the yarn label only knitted gauge, you may have to research the pattern yarn to determine its knitted gauge. This way, you can compare knitted gauges of the pattern yarn and the yarn you want to use. If the knitted gauges are the same, the new yarn you've chosen will substitute nicely. (You can research knitted gauge on the Internet or by asking at your local yarn store.)

- ✓ **Yardage:** Make sure to purchase enough yarn. Every type and brand of yarn varies in terms of the yards per ball or skein. Even when buying a worsted-weight skein from company X and one from Y, you may see a difference in yards per skein. For example, if your pattern calls for 5 balls of X at 100 yards a ball, and you buy 5 balls of Y at 80 yards a ball, you'll be short by a full ball!

Buying enough yarn at the beginning of your project is important because most yarns have dye lots (see the "Unraveling a yarn label" section). Although you may not be able to see the subtle differences in color before the yarn is worked, when your piece is crocheted, you probably won't like the contrast. Better to be safe than sorry. Most shops will let you exchange or return unused, unopened skeins of yarn if you purchase too much.

## *Getting Your Fingers Moving*

Whether you're brand-new to crochet or you learned the stitches years ago, it's well worth a few minutes to get a refresher on how to hold the hook and yarn and get started for your first few stitches.

To get started, you'll need a ball of yarn and a hook. Many beginners choose to practice using a size H-8 U.S. hook and worsted- or aran-weight yarn. Smooth yarn is easiest to work with at this point; too much texture makes it hard to see what you're holding.



Most of the instructions in this book are from a right-hander's perspective, but if you're a lefty, the same rules apply. You probably already have practice reversing directions, but here are a few tips to help you work from your point of view:

- ✓ **Mirror it:** Hold the picture up to a mirror to get a reverse view. It may feel a bit clumsy, but it should work well enough to get you going.
- ✓ **Flip it:** If you have a computer with a scanner, scan the illustration, and then use the photo software to flip the illustration horizontally. If you don't have a scanner, pull out some tracing paper and a pencil, trace the photo, and then view it from the opposite side.
- ✓ **Go righty:** Try crocheting the right-handed way. You may be surprised to find that you're ambidextrous.

## Holding the hook and yarn

Even though you use just one hook for crochet, both hands are involved in the action. Your dominant hand, the one you write with, holds and moves the hook. Your other hand is responsible for holding and tensioning the yarn.

You can hold the hook in one of two ways: over the hook, as in Figure 1-6, and under the hook, as in Figure 1-7. Neither grip is better or worse than the other. It's just a matter of what feels best in your hand.

**Figure 1-6:**  
The over-  
the-hook  
position  
for left-  
and right-  
handers.

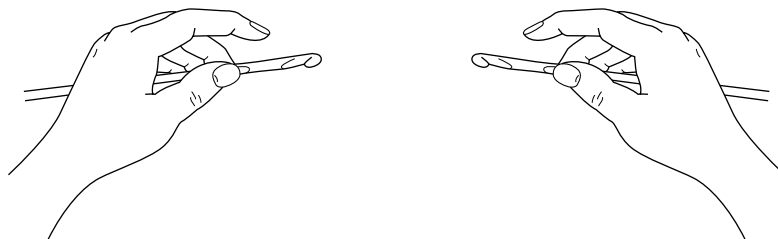

**Figure 1-7:**  
The under-  
the-hook  
position  
for left-  
and right-  
handers.

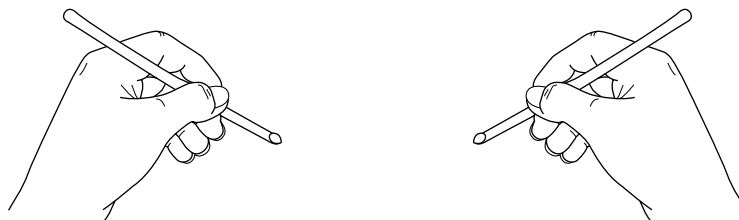

Now, you use your other hand to get a hold on the yarn. If you're right-handed, you use your left hand. If you're a lefty, you use your right. Although you can work with the yarn many different ways, here's one of the more common methods (see Figure 1-8):

1. **With the ball or skein positioned below your hand, bring the yarn up between your ring and little fingers.**
2. **Wrap the yarn around your little finger to create a loop.**  
This keeps the yarn from moving too quickly through your fingers, causing loose and sloppy stitches.
3. **Bring the yarn under your ring and middle fingers, and up to the top of your hand between your middle and forefinger.**

When you close your little, ring, and middle fingers to hold the yarn, you can use your forefinger to raise or lower the yarn. While you crochet, it's important to pay attention to the tension of the yarn. If it feels too loose, take time to readjust, working through the above steps.

**Figure 1-8:** Wrapping the yarn over your hand helps maintain good tension.

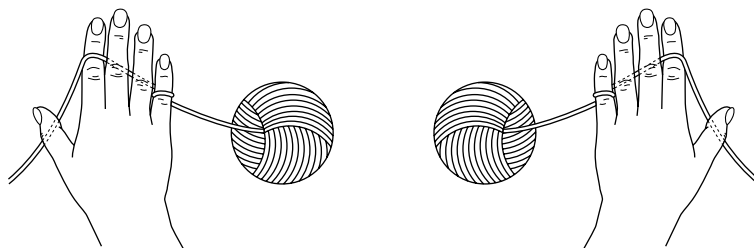

## *Working with the hook and yarn together*

You're comfortable holding your hook. You know how to control the yarn. Now you're ready to get the yarn on the hook and get crocheting. It all starts with a slipknot:

1. With about 6 inches of yarn, make a loop that looks like a pretzel (see Figure 1-9).

**Figure 1-9:** Starting a slipknot.

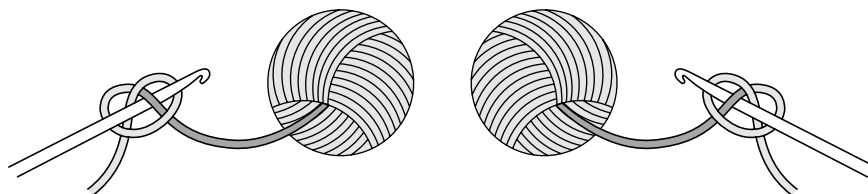

2. Insert your hook through the center of the loop, draw the yarn through the loop, and pull on the tail to tighten.

The slipknot should be loose enough to slide easily along the hook, but tight enough to avoid falling off. See Figure 1-10.

**Figure 1-10:** The slipknot tightened on the hook.

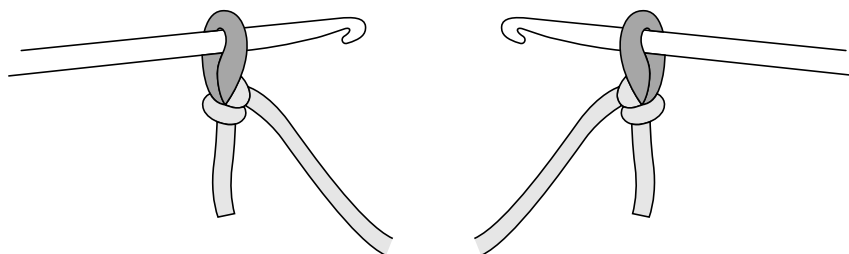

When you put everything together, your setup should look like Figure 1-11 or Figure 1-12, depending on which hand you use and whether you hold the hook underhand or overhand.

If this feels awkward at first, don't worry. With a little practice, you'll be able to get set up to crochet within seconds, without really thinking about it.

**Figure 1-11:**  
The correct  
position of  
both hands  
for the over-  
the-hook  
position.

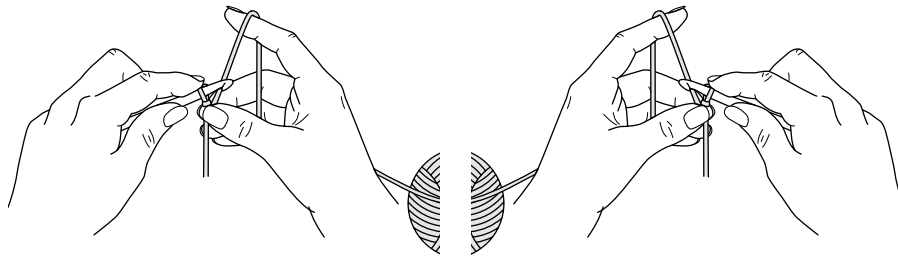

**Figure 1-12:**  
The correct  
position of  
both hands  
for the under-  
the-hook  
position.

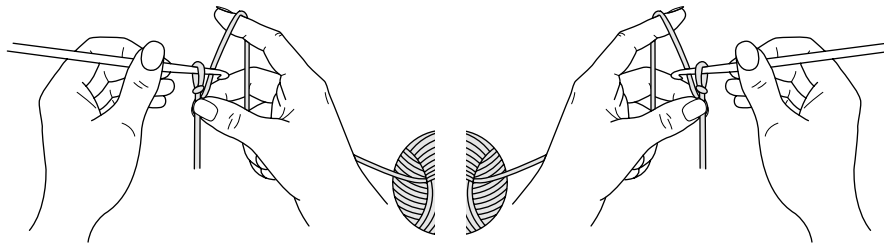

## It's in the Bag: Completing Your Crochet Kit

In addition to keeping the work off the couch and out of reach of pets, kids, and accidental spills, the advantages of keeping your yarn, pattern, finished pieces, notions, notes, and work-in-progress all together are numerous. With a dedicated crochet bag, you can quickly grab your project as you head off for a weekend away, an afternoon at a friend's house, or to a needlework guild meeting.

As simple and inexpensive as a leftover tote bag, or as luxurious as a just-for-crocheters designer bag, a dedicated place to store your project is a practical investment. If you've got multiple projects under way, consider placing each one inside a large freezer storage bag or other clear pouch so you can easily identify which is which.



It probably goes without saying that pets love yarn. It's soft, it's squishy, and it sometimes tastes like sheep. Although it may be cute to watch your kitten bat around a ball of yarn, it sets you up for a lifetime of problems when you go to work on your crochet. Much worse than that, even ingesting a few inches of yarn can cause a life-threatening emergency or death. Be safe. Always keep an eye on your yarn, and put it well out of reach in a closed crochet bag when you're not around.

Few things are more frustrating than getting ready to finish a project late at night and realizing that you're missing the yarn needle to sew it all together. Putting together a crochet kit, containing some inexpensive but often-used items, can help your projects go a lot more smoothly. Consider purchasing a small, zippered cosmetics pouch or other container to keep everything together and easily found in your crochet bag.

This list includes a few items that, although not always necessary, are great additions to your crochet kit. You probably already have most of them around the house — just gather them together and put them in a spot with your crochet hooks.



- ✔ **Scissors:** Try to find a small, blunt-nosed but sharp-bladed pair for snipping ends.
- ✔ **Hard ruler:** A 6-inch (or smaller) inflexible ruler is helpful for measuring your gauge.
- ✔ **Fabric tape measure:** Look for a retractable fabric tape measure for keeping track of your progress as you crochet. You also can use this tape measure for taking body measurements when crocheting a sweater, hat, or other garment.
- ✔ **Pins:** Straight pins, such as the type that sewers use, are handy when it comes time to sew your project together.
- ✔ **Removable stitch markers or coil-less safety pins:** Your craft or yarn store sells pouches of plastic stitch markers with an opening on one side. These are designed to go around the stitch itself and be removed easily later. Some crocheters prefer safety pins without the coil on one end. (The coil tends to snag.)  
  
Unless you're also a knitter, don't buy the solid stitch markers that are designed to sit on a knitting needle. You'll only have to cut them out of your work later.
- ✔ **Yarn and tapestry needles:** Consider purchasing a range of yarn needles in different sizes for different projects. Because these are small, they'll get lost easily, but you'll need one for weaving your ends and stitching project pieces together.
- ✔ **Pencil and paper:** Keeping track of your pattern progress can be helpful. A small notebook or pad of paper, plus a pencil or pen, makes life easier.





## Chapter 2

# Gauge and Garments: Sizing Facts and Figures

---

### *In This Chapter*

- ▶ Creating a gauge swatch
  - ▶ Figuring out those measurements
  - ▶ Selecting the proper size
- 

**E**veryone always talks about the importance of gauge, but what exactly is gauge? Why should you be so careful about attaining the same gauge as the pattern specifies? Simply put, *gauge* is the ratio of a given number of stitches and/or rows to inches (or other given measurement). You'll see it written like this:

**Gauge:** 12 sc and 8 rows = 4 in.

The reason gauge is so important is that the finished size of the pattern you're crocheting is based on this measurement. Now, if you're making an afghan and the finished size is off by a couple of inches, it's not quite so critical. But on the other hand, if it's a sweater you're making, being a few inches off could have a disastrous effect on the end result.

This chapter covers the basics of gauge — how to practice getting it right, how to measure it, and how to correct your gauge if you're off. I also talk about pattern sizes and how to make sure you get the fit you want when you're making sweaters, hats, skirts, and the like. Don't let the numbers scare you. They're necessary for making everything turn out just right!

## *Practicing with a Gauge Swatch*

The best way to ensure that you're working to the proper gauge is to crochet a *gauge swatch*, which is a reduced sample of the pattern. This allows you to work a small section of fabric to see how close you are to the given measurements. It also gives you the opportunity to practice the stitch pattern, which is really nice if it's a complicated one or is comprised of stitches you haven't worked before.

Working a gauge swatch is a very simple process and only takes a few minutes. If you're like me, you probably want to jump right in and start working on the project itself. But, again if you're like me, you've done this and cried over the finished design, wondering why it didn't come out right. Nine times out of ten the answer will be — the gauge was off.



Getting the gauge right is very important. Don't skip this step.

## Making a swatch

You need to make a gauge swatch whether you're working in rows or rounds:

- ✓ **Stitching a square:** To get an accurate measurement, the swatch should be at least 4 inches square, but it can be larger depending on the pattern. Read the gauge specifications at the beginning of the pattern, and then work the stitches for that pattern that accommodate those measurements.
- ✓ **Working a round:** The measurements given for a circular gauge will tell you what the diameter is for a given number of rounds. Follow the instructions for the pattern, being sure to crochet an extra few rounds above and beyond the number given for the gauge. This ensures that you can take a measurement in the middle of the piece, because the first and last round may be shorter or taller than a normal round, depending on the stitches used.

Typically, simple patterns that use one or two stitches repeated will give the gauge over 4 inches. For example, 12 sc and 8 rows measure 4 inches square. In this case, you would chain a few more stitches than noted and work rows of single crochet, without increasing or decreasing, until you've worked a few more rows than required.

To put this theory into practice, you can try your hand at making a quick gauge swatch using the double crochet stitch. Grab some yarn and a hook — anything will do.

**Gauge:** 11 dc = 4 in.

1. **Chain 20, turn, work one double crochet in the 4th chain from the hook, work one double crochet in each chain across.**
2. **Continue to work in rows of double crochet until the square measures slightly more than 4 inches square.**



When you've finished your swatch, take a set of gauge measurements. Then you can finish the swatch as you would the finished design, which typically involves *blocking*, a process that evens out the stitches and allows you to shape the piece. Depending on the type of yarn (don't forget to read the label), you can usually just wet or steam the swatch, shape it, and allow it to dry. Then take another set of measurements. This will give you an accurate gauge.



Your measurements may change, so if necessary, you should adjust your hook size based on the second set of measurements, which reflects a more accurate gauge. This is especially important when making garments: If your gauge shrinks (or grows) after blocking, you'll end up with a different size garment than you intended, which wouldn't do at all.

## Determining whether you're on the right track

Whether you're measuring an unblocked or a blocked swatch, you want to obtain the most accurate measurement possible, both in terms of stitches and rows. Specifically, you measure the swatch from side to side, counting the stitches, and from bottom to top, counting the rows.



When counting stitches and measuring rows, always use the center of the square swatch, rather than going from edge to edge (see Figure 2-1). Compare your measurement to those given in the pattern to determine the accuracy of your stitches. And make sure to position your ruler or tape measure evenly across the stitches and rows.

To measure stitches:

1. **Place the ruler at the left edge of a stitch and measure across to the left edge of another stitch (see Figure 2-1a).**

Make sure the ruler is level across the top of the row below.

2. **Count the stitches that you have in the 4 inches.**

The number of stitches you count should equal the gauge given for the pattern.

You can count half stitches too. If you're even a half of a stitch off, your finished piece may be several inches too big (or too small).



It's essential to count accurately; don't stretch or distort your crochet to get the "right" number. If your gauge isn't perfect the first time around, you can change hook size later to get everything right.

To measure rows:

1. **Align the ruler's edge vertically to the side edge of the stitches, making sure it's evenly positioned (see Figure 2-1b).**
2. **Count rows, keeping track of any partial rows.**

Because a crochet row can be quite tall, you need to measure as accurately as possible. Again, in an ideal world, the number of rows will match the gauge given in the pattern.

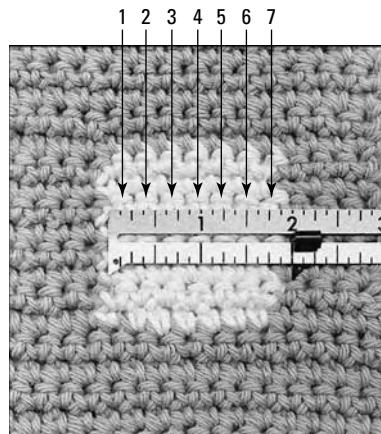

a.

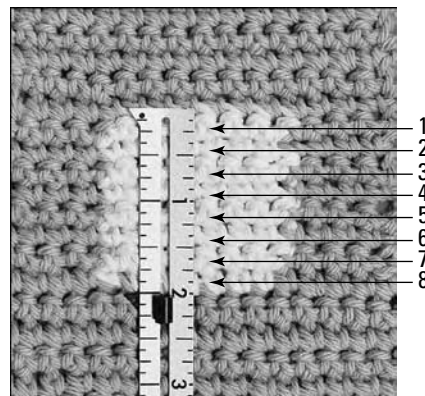

b.

**Figure 2-1:**  
Measuring  
gauge in  
stitches  
and rows.



You can use these steps to measure the gauge of the practice swatch you made in the last section to see how close your gauge is to the one given in the pattern. And if your gauge is off (either in rows or stitches), don't fret. The next section, "Making adjustments," helps you correct the problem.

When measuring gauge in the round, measure from the outside edges of the given round through the center of the swatch (see Figure 2-2). Figure 2-2a shows three rounds of double crochet stitches that equal  $3\frac{1}{2}$  inches in diameter. Figure 2-2b shows two rounds of a motif that equal 3 inches in diameter across the widest point.

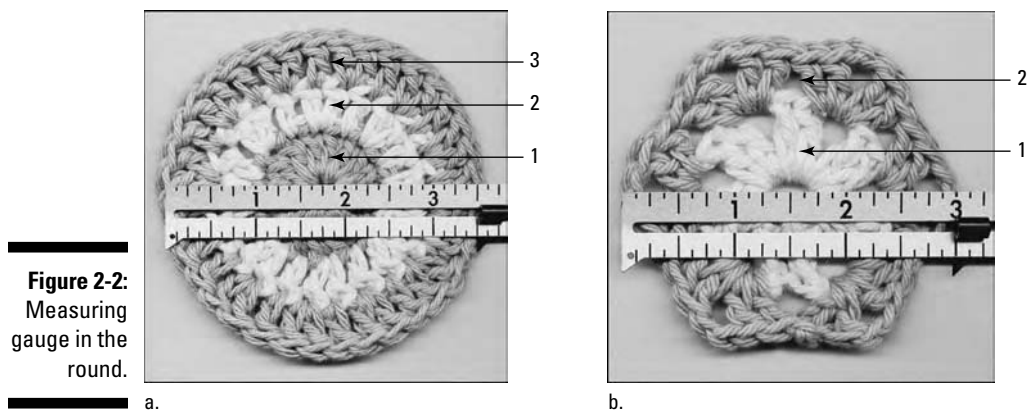

**Figure 2-2:**  
Measuring  
gauge in the  
round.

If, after you measure your swatch, the gauge is right on, then you're good to go, and you can jump right in to the project. However, if you have too many stitches, then you're crocheting too tight and you have to loosen up a bit. If you have too few stitches, then you're too loose and need to tighten up. But don't try to adjust your crochet tension to correct the problem! The next section tells you what to do instead.

## Making adjustments

The best way to achieve the correct gauge is to change hook size. If your stitches are too tight, use the next larger hook size. If they're too loose, use the next smaller size. It's okay to use a different hook size because the gauge of the finished piece is way more important than what hook you use to create it. And when you change hook size, make another swatch to make sure the gauge is correct.



Don't try to adjust your crocheting! Everyone has a natural way to crochet, and if you try to change your method, you'll invariably end up right back where you started.

## Sizing Your Garment

This section covers a subject that I dearly wish clothing manufacturers would pay more attention to — sizing. I'm sure you've noticed that just because a label says a sweater is a certain size, it doesn't mean it really is that size. This makes me absolutely crazy when I shop — the stuff I can wear spans three different sizes, and I don't even know which one is correct anymore. There are, however, standards in sizing, even if many manufacturers don't pay much attention to them.

The good news is that when you're making your own clothing, you can pay attention to sizing and get the fit just right. You can take basic measurements, decide how you want the garment to fit, and then figure out which size to make to meet your particular needs.

## Tale of the tape: Taking accurate measurements

To ensure that the finished garment you're crocheting actually fits, you must first take correct body measurements. This isn't difficult or time consuming; you just have to know where to measure. To take accurate measurements, make sure to have a fabric tape measure on hand.



When taking your measurements, it's easiest (and more accurate) to ask someone else for help! Also, be sure to take your measurements often; don't just rely on numbers from a few years back.

### *Sweaters and vests*

Most garment patterns give specific finished measurements for things such as bust, waist, back length, and sleeve length. These finished measurements, in most cases, are designed to be a few inches larger than your actual body measurements. This concept is called *ease*. So, to select the right size, think about how you want the sweater or vest to fit.

- ✔ Do you want it fairly close to your body? If so, selecting a size an inch or so larger than your actual chest measurement is the way to go.
- ✔ If you'd like a bit more room, select a size 2–4 inches larger than your actual measurement.
- ✔ Is the garment supposed to be quite oversized? Go for even more ease.



What you plan on wearing underneath impacts sizing too. If you're wearing the top over a close-fitting camisole, you'll need less ease than if you plan to wear it over a heavy turtleneck.

If you match up your measurements to the corresponding size in the pattern, your finished sweater or vest will fit just the way you want (assuming your gauge follows the pattern specifications). Figure 2-3 shows how to measure various areas to ensure a great outcome.

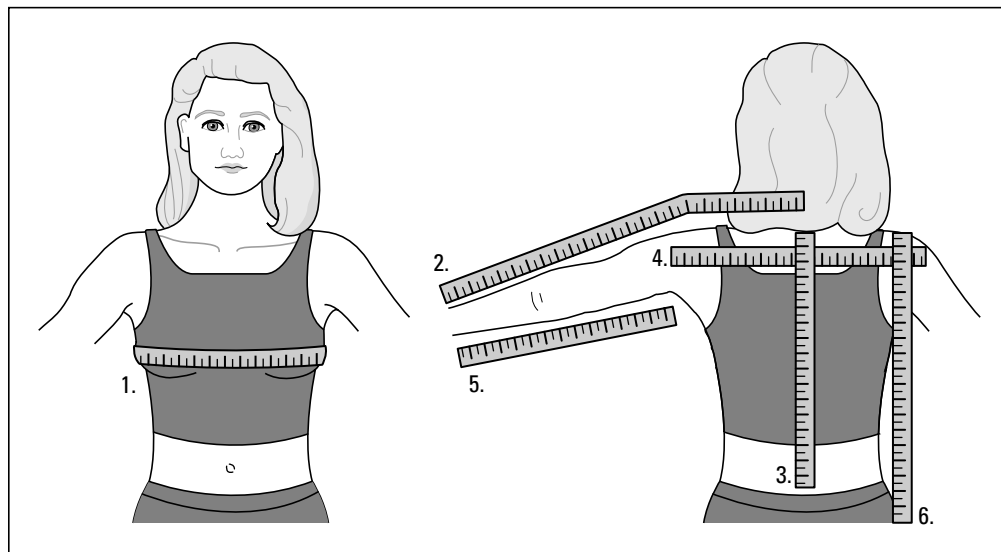

**Figure 2-3:**  
Measuring  
areas of  
the body  
correctly.

- ✔ **Chest or bust (1):** Measure around the fullest part of your model's chest or bust. Don't draw the tape too tightly or measure while inhaling or exhaling.
- ✔ **Center back, neck-to-cuff (2):** With the model's arm slightly bent, measure from the back base of the neck, across the shoulder, and around the bend of the elbow to the wrist.
- ✔ **Back waist length (3):** Measure from the most prominent bone at the base of the neck to the model's natural waistline.

- ✓ **Cross back (4):** Measure from shoulder to shoulder.
- ✓ **Sleeve length (5):** With your model's arm slightly bent, measure from her armpit to cuff.
- ✓ **Back hip length (6):** Measure from the top of the model's shoulder to the top of the hip.

## Hats

For an accurate head measurement, place a tape measure across the forehead and measure around the full circumference of the head. Keep the tape snug for accurate results. Figure 2-4 shows you how.



**Figure 2-4:**  
Measuring  
head cir-  
cumference.

## Skirts

For skirts, a waist measurement is most helpful. Before measuring, think about where the skirt should hang. Will it sit at the natural waist or lower on the hips? Wrap the tape measure around the body at the position where you want the top edge of the skirt's waistband to hit and take the reading.

After you've determined the position of the skirt's waistband, tie a string or length of yarn loosely around the body at this position. Then, beginning at this line, let the measuring tape hang straight down. Get a friend to help, or look in a mirror, to determine the hem length you'd like.

## *Fit to be sized: Adjusting the fit*

After you've chosen the proper size for the project you want to crochet (see the previous section), you can think about some simple adjustments. The length of a garment is generally the easiest to adjust.

## *Sweaters and vests*

Whether you're crocheting a top for a woman, child, or man, taking a few additional measurements can help you adjust the length of the pattern.



- ✓ For a waist-length garment, take the measurement from the top of the model's shoulder down to the place where her pants sit.
- ✓ For a hip-length garment, measure past the top of the pants by 2 or 3 inches.
- ✓ For a tunic length, your measurement will be even longer, up to mid-thigh.

Now, compare the measurement for the length you want to the finished length listed in the pattern. If the woman's jacket you like has a finished length of 20 inches for your size, but you'd like it to be more of a coat length, your desired finished measurement may be 24 or 26 inches.



If you want to add additional length, do it before any waist shaping on a woman's garment or any time after the hem on a child or man's garment.



If the sweater you want to crochet isn't sized large (or small) enough in the chest, it's generally too difficult to rewrite the pattern to allow for the change in width, unless you'd like to take on a big project. Instead, consider using a thicker (or thinner) yarn for slight adjustments. Or search for another pattern.

### **Hats**

The easiest adjustment to make to a hat pattern is to alter the length of the hat. Want a hat with a fold-up brim? Increase the length by enough inches to compensate for the fold. How about adding a flared brim? If the hat is worked from the top down, add some increases a few rows before finishing, and you'll have a floppy, ruffled edge.

### **Skirts**

If you want to change the length of a skirt, consider its shape. For a skirt with little or no shaping, like a straight pencil skirt, you can shorten or lengthen at any point between the hem and the waist.

For skirts with more shaping, such as flouncy or A-line shapes, think about where you want the length to be altered. Adding length at the widest portion will make the skirt seem fuller all around, while removing length here will make it slimmer. Making adjustments to the slimmer portion of the skirt will have the opposite effect. You may choose to add (or subtract) a little length in both places to keep the look proportional.

## ***Picking the Right Pattern Size***

The following charts will help when determining which pattern size is correct (see Tables 2-1, 2-2, 2-3, 2-4, and 2-5). Take your measurements, or those for whom the sweater will be made, and choose the size in the pattern you're making that corresponds the best. Don't worry if your numbers don't match the pattern exactly — a half inch or an inch here and there won't make a huge difference, but if in doubt, go to the next larger size. Decide how much ease you'd like in the sweater (see the "Tale of the tape: Taking accurate measurements" section earlier in the chapter), then pick the size that comes closest to that measurement. If you can't take measurements of the person for whom the sweater is being made, the charts in this section should help you determine which size should fit best.

If you're wondering where the chart is for skirt sizes, I'm sorry to say you won't find one. In the crochet world, skirt sizes haven't been standardized because the fit depends on whether the skirt is meant to hang from your hips or your waist. The Craft Yarn Council, the group that works on standardizing measurements, hasn't provided a chart for skirt sizing yet.

Even though this book doesn't include patterns for babies, children, or men, the size charts for these folks are still useful to have. You never know when you'll need to crochet a garment for someone in this group.

The last thing to keep in mind is that patterns are far from standardized. The measurements in the following charts have been in use for many years, and are pretty accurate, but always check each pattern individually, and don't assume the measurements given will match the numbers below.

<b>Table 2-1 Baby Size Chart</b>					
<b>Baby's Size</b>	<b>3 Months</b>	<b>6 Months</b>	<b>12 Months</b>	<b>18 Months</b>	<b>24 Months</b>
Chest (in.)	16	17	18	19	20
Center Back Neck-to-Cuff	10½	11½	12½	14	18
Back Waist Length	6	7	7½	8	8½
Cross Back (Shoulder to Shoulder)	7¼	7¾	8¼	8½	8¾
Sleeve Length to Underarm	6	6½	7½	8	8½

<b>Table 2-2 Child Size Chart</b>								
<b>Child's Size</b>	<b>2</b>	<b>4</b>	<b>6</b>	<b>8</b>	<b>10</b>	<b>12</b>	<b>14</b>	<b>16</b>
Chest (in.)	21	23	25	26½	28	30	31½	32½
Center Back Neck-to-Cuff	18	19½	20½	22	24	26	27	28
Back Waist Length	8½	9½	10½	12½	14	15	15½	16
Cross Back (Shoulder to Shoulder)	9¼	9¾	10¼	10¾	11¼	12	12¼	13
Sleeve Length to Underarm	8½	10½	11½	12½	13½	15	16	16½

<b>Table 2-3 Woman Size Chart</b>									
<b>Woman's Size</b>	<b>X-Small</b>	<b>Small</b>	<b>Medium</b>	<b>Large</b>	<b>1X</b>	<b>2X</b>	<b>3X</b>	<b>4X</b>	<b>5X</b>
Bust (in.)	28–30	32–34	36–38	40–42	44–46	48–50	52–54	56–58	60–62
Center Back Neck-to-Cuff	27–27½	28–28½	29–29½	30–30½	31–31½	31½–32	32½–33	32½–33	33–33½
Back Waist Length	16½	17	17¼	17½	17¾	18	18	18½	18½

<b>Woman's Size</b>	<b>X-Small</b>	<b>Small</b>	<b>Medium</b>	<b>Large</b>	<b>1X</b>	<b>2X</b>	<b>3X</b>	<b>4X</b>	<b>5X</b>
Cross Back (Shoulder to Shoulder)	14–14½	14½–15	16–16½	17–17½	17½	18	18	18½	18½
Sleeve Length to Underarm	16½	17	17	17½	17½	18	18	18½	18½

**Table 2-4 Man Size Chart**

<b>Man's Size</b>	<b>Small</b>	<b>Medium</b>	<b>Large</b>	<b>X-Large</b>	<b>XX-Large</b>
Chest (in.)	34–36	38–40	42–44	46–48	50–52
Center Back Neck-to-Cuff	32–32½	33–33½	34–34½	35–35½	36–36½
Back Hip Length	25–25½	26½–26¾	27–27¼	27½–27¾	28–28½
Cross Back (Shoulder to Shoulder)	15½–16	16½–17	17½–18	18–18½	18½–19
Sleeve Length to Underarm	18	18½	19½	20	20½

**Table 2-5 Head Circumference Chart**

	<b>Preemie</b>	<b>Baby</b>	<b>Toddler</b>	<b>Child</b>	<b>Woman</b>	<b>Man</b>
Circumference (in.)	12	14	16	18	20	22



## Chapter 3

# Sum and Substance: Reading a Pattern

### *In This Chapter*

- ▶ Brushing up on abbreviations
- ▶ Rehashing repeats: Bullets, brackets, and parentheses
- ▶ Deciphering stitch diagrams

**B**esides knowing how to make the stitches, the most important aspect of crocheting is being able to read a pattern. At first glance, patterns may appear to be nothing more than a lot of gibberish, but that's simply not so. If you think about all the stitches that go into a project, be it large or small, and realize that each stitch has to be written out in some form or another, you realize why creating an abbreviated language was necessary. Imagine the length of a crochet pattern if each stitch had to be written out — you'd have what amounts to an epic novel for each one.

In an effort to keep instructions relatively short and uncluttered, crochet patterns and diagrams are created using abbreviations and symbols. The language has developed over the years and is relatively simple and mostly common sense. The more patterns that you read, the easier it becomes to recognize each abbreviation and symbol. Pretty soon it'll become just like a second language, and you won't have to put much thought into it at all.

## *Interpreting the Written Instructions*

A crochet pattern is more than just a set of abbreviations and symbols. In addition to line-by-line directions, it includes everything you need to know to replicate the item as pictured. From yarn quantities to hook sizes to any additional notes about the pattern construction, you'll find it all in a well-written crochet pattern.



Always read the section at the very beginning of the pattern. This is where you find all the crucial information you need before you get started: yarn, hook size, gauge, garment sizes (if applicable), and any special stitches used in the pattern. Be sure to pay attention to special stitches because they vary from pattern to pattern, and practice any that you're unfamiliar with. (For hints on making a practice swatch, flip to Chapter 2.)



Always read through the pattern instructions before you get started. If you come across any instructions that seem confusing or that you don't quite understand, read through the pattern again. Eventually, it'll make sense, or you can ask someone to explain it to you. It's better to figure out complicated instructions before you get started than to have to rip out work that's not right.

## Understanding the abbreviations

When it comes to the written instructions, it's clearer and more efficient to use a series of standardized abbreviations. For instance, instead of writing out *single crochet stitch* each time it's used in a pattern, the instruction will just say *sc*. You'll notice that there are generally no periods after an abbreviation, unless it comes at the end of a sentence. This keeps the instructions from getting too cluttered. But when it comes to *in*, I put a period after it to designate the abbreviation for *inches* (in.), so you don't think I mean the word *in*.

Table 3-1 lists the most commonly used abbreviations (there's also a handy pocket version of these abbreviations on the Cheat Sheet at the front of the book). Although the list is by no means all-inclusive, all of the abbreviations in the patterns found in this book are contained in the list. So if you get stuck while working one of the patterns, flip to this table for a memory boost.

<b>Abbreviation</b>	<b>Spelled-Out Term</b>
approx	approximately
beg	begin(ning)
bet	between
blp	back loop only
BP	back post
CC	contrasting color
ch	chain
dc	double crochet
dec	decrease(s)(d)(ing)
dtr	double triple crochet
flp	front loop only
foll	follow(ing)
FP	front post
hdc	half double crochet
inc	increase(s)(d)(ing)
MC	main color
pat	pattern
rem	remaining
rep	repeat
rib	ribbing
RS	right side
sc	single crochet

<i>Abbreviation</i>	<i>Spelled-Out Term</i>
sl st	slip stitch
st(s)	stitch(es)
tog	together
tr	triple crochet
WS	wrong side
yo	yarn over

## Taking note of common terms

In addition to stitch abbreviations, other phrases that you'll frequently run across refer to where to work stitches or how to proceed with the pattern without having to actually write out each and every stitch, row, or round. The following list contains some commonly used terms:

- ✔ **Space:** A space usually refers to the space that's created by 1 or 2 chain stitches worked between other stitches. To work in a *ch-space*, insert your hook into the space underneath the chain stitches and complete the specified stitch.
- ✔ **Loop:** A loop is 3 or more chain stitches worked in a row. *Ch-loops* are quite often seen in lacy patterns and threadwork. To work in a *ch-loop*, insert your hook underneath the loop and not into any particular chain stitch.
- ✔ **Work across:** Crochet the designated stitches across the whole length of the row.
- ✔ **Work around:** Crochet the same stitch or pattern repeatedly until you come back to where you started.
- ✔ **Work to within last st:** Crochet following the pattern until you have one stitch left in the row or round. The instructions will tell you what to do with this last stitch. You may also see this for 2, 3, or more stitches at the end of a row or round.
- ✔ **Established pat:** This phrase is most often seen when crocheting garments. The stitch pattern will be written out in the first few lines of the instruction, then, rather than keep writing out the same thing over and over, you'll be told to work in *established pat*, which means to repeat the stitch pattern over and over until the instructions tell you to do something else.
- ✔ **Work even:** This means to continue crocheting on the same number of stitches that you currently have on your work without making any increases or decreases.

## Deciphering the symbols

When you read a crochet pattern, you'll notice some punctuation and symbols that you don't encounter very often in everyday reading. Bullets, brackets, and parentheses appear all over the place in written instructions, and each one has its own meaning (or in some cases, more than one meaning). You must be able to interpret these symbols correctly or you may be in for a big surprise when you get to the end of your design.



Whether working in rounds or rows, punctuation serves the same purpose.

***Bouncing bullets***

Because crochet patterns tend to have repeating sets of stitches that you work across an entire row or round, it makes sense to write them only once, then instruct you to repeat them a given number of times. Several different symbols are used to denote the repeats, such as bullets (•), asterisks (\*), plus signs (+), and crosses (†). Bullets and asterisks are the most common, and throughout this book, I use bullets in the patterns.

***Single bullets***

Bullets are used basically two different ways:

- ✓ To enclose an entire phrase, with a bullet at each end
- ✓ At the beginning of a phrase, with repeat instructions immediately following

Either way is correct; it really just depends on the preference of the publication.

For a repeat that has only one bullet, you'll see something like this:

- Sc in next st, ch 1, skip next st, rep from • 4 times.

In plain English, this means to work the stitches after the bullet once, then repeat those same stitches 4 more times for a total of 5 times.

If you see a phrase that has bullets at both ends, enclosing the entire phrase, it may look like this:

- Ch 3, • dc in each of next 2 sts, ch 2, skip next 2 sts •, rep from • to • twice, dc in each of next 5 sts, ch 2, skip next 2 sts, rep from • to • 3 times, dc in last 3 sts.

In this case, you would work the stitches between the bullets 3 times, then work the stitches immediately following the phrase, then work the stitches between the bullets another 3 times, then finish out the rest of the instructions.

Bullets are nice because they can be referred to more than once within a row without having to rewrite the stitches. You won't find, however, a phrase between bullets referenced within another row. Each row or round has its own separate set of instructions.

***Double bullets***

Once in a while, you'll come across double bullets (••) enclosing a phrase. These can be used in one of two ways:

- ✓ To note a second section to be repeated in any line of instructions
- ✓ To note a group of instructions, including at least one single-bullet repeat, that will be repeated

In general, double bullets denote a second section of instructions to repeat when there's already a single-bulleted section in the same row or round. When a particular row or round has two sets of instructions that need repeating, you'll see a set of stitches enclosed in single bullets first, then a section later on enclosed by a set of double bullets. For example:

- Dc in each of next 2 sts, ch 2, skip next 2 sts •, rep from • to • twice, •• dc in each of next 3 sts, ch 2, skip next 2 sts ••, rep from •• to •• twice, dc in each of last 2 sts.



Simply put, you would work the stitches between the single bullets for a total of 3 times, then work the stitches between the double bullets, which are different than the phrase between the single bullets, a total of 3 times, then complete the rest of the row.

When a set of instructions enclosed in single bullets is part of a larger repeat, you'll find double bullets at either end of the larger repeat. For example:

•• 5 dc in loop, ch 2, skip next 2 dc, • dc in next dc, ch 2, skip next 2 dc •, rep from • to • 5 times ••, rep from •• to •• 3 times.

In other words, you work the •• to •• phrase a total of 4 times, but within that phrase is another • to • phrase that you work a total of 6 times within each •• to •• repeat.

### *Playing with parentheses*

Parentheses are another way to denote repeats within an instruction; however, their role is slightly different than that of bullets. Here's a list of the parentheses' purpose:

- ✔ **To isolate a set of stitches that are worked all in 1 stitch.** For example,

(dc, ch 1, dc) in next sc

This means that in the next single crochet stitch, you work 1 double crochet, chain 1, then another double crochet in the same single crochet.

- ✔ **To enclose a set of stitches that you repeat a number of times in succession, in the same way that single or double bullets would be used.** For example,

(3 dc in next st, ch 1, skip next st, sc in next st, ch 1, skip next st) 4 times

Simply put, this means that you work 3 double crochet in the next stitch, chain 1, skip the next stitch, single crochet in the next stitch, chain 1, skip the next stitch, then repeat the stitches within the parentheses 3 more times for a total of 4 times.

- ✔ **To sum up a completed row or round.** At the end of a row or round, you'll see a number enclosed in parentheses that tells you how many stitches you should have (25 dc). Or, it could say (15 shells) or (6 ch-5 loops). These numbers help keep you on track so you know if you've made the correct number of stitches called for in the instructions.

- ✔ **To distinguish different sizes in garment patterns.** Most garment patterns are written in a variety of sizes to accommodate all of our different sizes. In order to distinguish the number of stitches needed for the different sizes, you'll see something like this:

Sc in each of next 24 (26, 28, 30) sts

Now, the pattern will tell you at the beginning which sizes are which, but for the sake of this example, if you were making a size Small you'd work 24 single crochet stitches, a size Medium you'd work 26 single crochet stitches, a Large 28 single crochet stitches, and an X-Large 30 single crochet stitches.

To avoid confusion as you work, it's helpful to highlight, circle, or underline the numbers that pertain to your size throughout the pattern.



***Embracing brackets***

Brackets are used in similar fashion to parentheses, usually in conjunction with them. Sometimes they are used interchangeably, but other times they are used like this:

- ✓ **As a set or phrase within another phrase.** For example:

(2 dc in center ring, [ch 3, sl st in 3rd ch from hook]) 3 times, 2 dc in center ring, sl st in first dc to join.

In plain English, this means you would work 2 double crochet stitches in the center ring, chain 3, then slip stitch in the 3rd chain from your hook, a total of 3 times, then work another 2 double crochet in the center ring before working a slip stitch to the beginning double crochet to join the stitches into a round.

- ✓ **To sum up the number of stitches at the end of a row for different sizes.**

For example:

(85 [90, 95] sts)

For a size Small you'd have 85 stitches at the end of the row, 90 stitches for size Medium, and 95 stitches for size Large.

***Rows and rounds repeated***

The other type of repeat that you're likely to come across is one that instructs you to repeat several identical rows or rounds in succession. You may see something like this:

**Rows 2–10:** Ch 1, sc in each sc across, *turn*.

This means that you chain 1, single crochet in each single crochet across, then turn at the end of the row consecutively for 9 rows.

Sometimes the pattern will instruct you to repeat a number of rows, like this:

**Row 2:** Ch 1, sc in each st across, *turn*.

**Row 3:** Ch 2, hdc in each sc across, *turn*.

**Row 4:** Ch 3, dc in each hdc across, *turn*.

























**Rows 5–13:** Rep Rows 2–4 (3 times).

For this type of repeat, you work Row 2 through Row 4 as written, then go back and repeat them consecutively 3 more times for a total of 9 more rows.

## ***Decoding the Diagram***

Stitch diagrams are a wonderful tool to use in addition to written instructions. They portray a picture of the design, which is especially helpful with more intricate patterns. They lay out each individual stitch in relation to the others so you can see what the design is supposed to look like when you're finished. Additionally, if you happen to see a pattern in a foreign publication that has a stitch diagram, you can still make the item without hiring a translator.

The stitch symbols that are used to make up these stitch diagrams are called *International Crochet Symbols*. These symbols aren't quite standardized yet, and you'll most likely find slight variations from publication to publication, but they'll be close enough that you'll recognize them. Figure 3-1, as well as the removable Cheat Sheet at the front of the book, includes a list of the symbols for the most common crochet stitches and stitch combinations. Keep this list handy as you crochet.

chain stitch ( <b>ch</b> )		V-stitch ( <b>V-st</b> )	
slip stitch ( <b>sl st</b> )	• OR 	crossed double crochet ( <b>crossed dc</b> )	
single crochet ( <b>sc</b> )	 OR 	shell [of 4 dc]	
half double crochet ( <b>hdc</b> )		picot [of ch 3, sl st]	
double crochet ( <b>dc</b> )		cluster [of 4 dc]	
triple crochet ( <b>tr</b> )		reverse [sc]	
double triple crochet ( <b>dtr</b> )		puff st [of 3 dc]	
triple triple crochet ( <b>trtr</b> )		popcorn ( <b>pop</b> or <b>pc</b> ) [of 5 dc]	
single crochet in front loop only ( <b>flp</b> )		bobble [composed of 5 loops]	
single crochet in back loop only ( <b>blp</b> )		loop stitch ( <b>loop st</b> )	
front post double crochet ( <b>FP dc</b> )		long stitch ( <b>long st</b> ) or spike	
back post double crochet ( <b>BP dc</b> )			

**Figure 3-1:**  
International  
Crochet  
Symbols.



Keep these basics in mind when crocheting from a stitch diagram:

- ✓ Each row or round is numbered so you know where to begin.
  - When working in rows, the right-side row number appears on the right-hand side of the diagram, which means you work from right to left. The wrong-side number is placed on the left-hand side of the diagram, and you work following the diagram from left to right.
  - When working in rounds, the number that appears in the center of the center ring indicates the number of chain stitches used to form the ring. Each subsequent round is then numbered at the beginning of each round.
- ✓ Because of the repetitive nature of crochet instructions and the space limitation of most publications, a stitch diagram may show only a repeated set of stitches a few times, but that will be all you need to crochet the entire piece.
- ✓ When working in rounds, work counterclockwise without turning between rounds unless the written instructions specifically tell you to.
- ✓ Crochet is three-dimensional, while stitch diagrams are not. You may see some distortion of the stitches in the diagram that won't be there in the actual crocheted piece. Always check out the written instructions before working exclusively from a diagram.

Figure 3-2 is an actual stitch diagram for a pillowcase edging that appears in Chapter 14. Because the stitch pattern is repetitive, only a small portion of the pattern is represented. This is commonly called a *reduced sample* of the pattern. It includes at least one repeat, plus any edge stitches so you can see how they join together. When working your actual piece, you start out with the specified number of chain stitches for your foundation chain, then repeat the pattern across. Notice how the right-side row is numbered on the right-hand side of the diagram and the wrong-side row is numbered on the left-hand side.

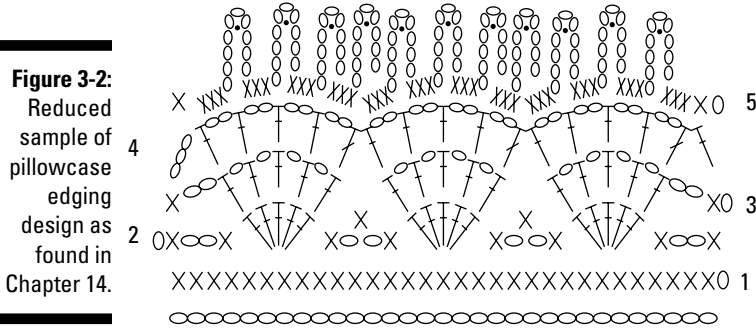

## Chapter 4

# Brushing Up on Stitch Basics

### *In This Chapter*

- ▶ Reviewing basic crochet stitches
- ▶ Stitching creative combinations
- ▶ Switching to a new color or skein of yarn
- ▶ Shaping your design by increasing or decreasing stitches
- ▶ Working in circles to crochet round designs

**T**his chapter is all about action — the stitches and stitch combinations, how to add a new ball of yarn, changing colors, increasing and decreasing your stitches, and working in circles. You need to know how to do all of these things because they're what make crochet interesting.

In this chapter, you find descriptions of stitches and their relationship to each other. I give you a detailed explanation about how to add a new ball of yarn, whether it's the same color or a new one, and how to do it without color drag. When you want to shape your work, you need to know all about increasing and decreasing your stitches, whether you're working in rows or rounds, and that how-to is here, too. So skim through these pages and refresh your memory. Then you can jump into your first pattern.

## *Keeping You in Stitches*

As I'm sure you know, crocheting is nothing more than a series of loops made with a hook and yarn. You can work those loops back and forth, back and forth across the rows, or around and around in circles. Appendix A goes into great detail on how to create each of these stitches, but the following sections should give you a memory boost about the relationship between the stitches and how they can be combined to create new stitches.

### *Refreshing the fundamentals*

Even the most complex crochet stitch patterns do nothing more than build upon these basic stitches. When you're comfortable with these stitches, you'll run into few unfamiliar techniques down the road.

- ✓ **Slip stitch:** This is the flattest of all stitches and is quite utilitarian. Besides being used as a regular stitch, the slip stitch is also used to join rounds, travel (when you need to get from point A to point B without fastening off your yarn), sew seams, and create combination stitches.
- ✓ **Single crochet stitch:** This is probably the most commonly used stitch and is the basis for all other crochet stitches. The single crochet stitch is short and compact and works just as well with a smooth yarn as with the new, textured fashion yarns.

- ✔ **Half double crochet stitch:** This stitch is a little bit fatter and a little bit taller than a single crochet stitch. It creates a nice, dense fabric without being too stiff. When working a half double crochet stitch, you start out like a double crochet stitch and end like a single crochet stitch.
- ✔ **Double crochet stitch:** This is another really popular stitch and is used quite often alone and in combinations to create other patterned and textured stitches. The double crochet stitch is slightly taller than the half double crochet stitch and creates a fairly loose fabric.
- ✔ **Triple crochet stitch:** This one builds on the double crochet stitch, and again, is just a bit taller. When worked in rows, the triple crochet stitch creates a loose, airy fabric and is often used in combination with other stitches to crochet lace-like patterns.
- ✔ **Double triple crochet stitch:** This is most likely the tallest stitch you'll see on a fairly regular basis. It is taller than the triple crochet and is most used in thread-work to create lace patterns.

All of the stitches listed above are about the same width, with the exception of the half double crochet, which has the distinction of being fat. The big difference between the rest of them is the height. You need to know how tall a stitch is so you know how long to make your turning chain. When you get to the end of a row or round, you have to bring your work to the next level, and this means working a *turning chain*. Figure 4-1 shows you how many chains to make as well as the height relationship between each stitch. Table 4-1 tells you how many chains are needed for these frequently used stitches.

**Figure 4-1:**  
Because stitches are different heights, your turning chain has to be different lengths.

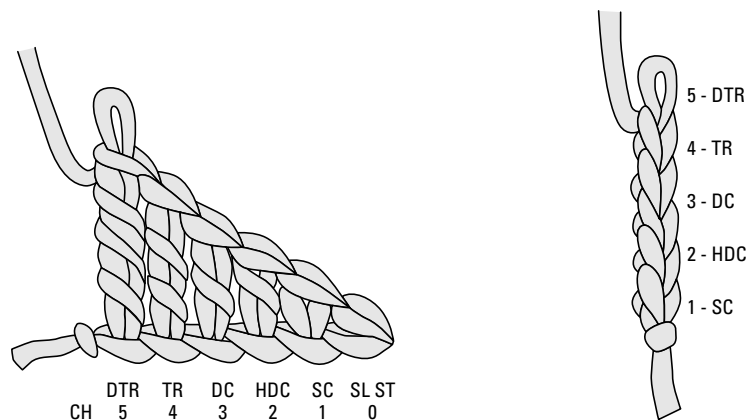

**Table 4-1** How Many Chain Stitches Make a Turning Chain?

<i>Stitch Name</i>	<i>Number of Turning Chains Needed</i>
Slip stitch (sl st)	0
Single crochet (sc)	1
Half double crochet (hdc)	2
Double crochet (dc)	3
Triple crochet (tr)	4
Double triple crochet (dtr)	5



When you start the next row or round, you have to bring your work up to the correct height of the stitch you'll be working next. Many patterns will tell you how many chains to make for the turning chain, but some don't. If the row starts out with a double crochet (dc), be sure to chain 3 instead of working an actual double crochet stitch.

In addition to bringing the hook to the proper height before working the next row or round, sometimes the turning chain counts for an actual stitch. In patterns, you may see this written as, "Ch 3 (counts as 1 dc), dc in next and foll 3 sts . . ." If a turning chain stands in for a "normal" stitch, you can expect to work the final stitch of the *next* row into that turning chain. When working in single crochet, the chain 1 is never used in place of a stitch; it simply isn't big enough to work into later on. Throughout this book, every turning chain larger than a chain 1 counts as a stitch.

## Constructing combinations

One of the things that I absolutely love about crochet is that you can take the simplest stitches and create wonderful patterns and textures without having to learn new techniques. Pattern and texture stitches come in all shapes and sizes. The toughest part about stitch combinations is deciding where to place your hook and how many yarn overs you need.

If a pattern includes a special stitch, it'll give you the instructions on how to make that stitch at the beginning of the pattern. However, you'll see certain stitches on a fairly regular basis. The list below names a few, and Appendix A gives you step-by-step instructions for each of them. Although this list is by no means all-inclusive, these stitches give you a good base for creating pattern and texture.

- ✔ **Shell stitch:** This is typically made by crocheting anywhere from three to five double crochet stitches all in the same stitch. The resulting pattern looks like a seashell.
- ✔ **V-stitch:** Like the name suggests, this stitch looks like a V. It's usually made by crocheting a double crochet stitch, chain 1, double crochet stitch all in the same stitch.
- ✔ **Crossed double crochet stitch:** This one looks like an X when it's complete. The double crochet stitches are worked on an angle, where you skip a stitch for the first double crochet, then work backward into the skipped stitch for the second double crochet.
- ✔ **Picot:** These are most often used on edgings. They are pretty little round-shaped stitches that add a decorative touch or fill an empty space. Picot stitches are almost always made by crocheting three chain stitches and then a slip stitch into the third chain from the hook.
- ✔ **Cluster:** The opposite of the shell stitch, the cluster looks like a triangle. It's formed by working a number of stitches across an equal number of stitches and joining them together across the top. It's similar to a decrease. Any of the basic stitches can be used to make a cluster, although it's most common to use half double crochet, double crochet, and triple crochet.
- ✔ **Reverse single crochet:** Just as the name suggests, this is a single crochet stitch, but instead of working it from right to left, you work it from left to right creating a decorative twisted rounded edge.
- ✔ **Puff stitch:** As the name suggests, this stitch puffs up into a gently formed oval. It's created by crocheting several half-closed stitches all in the same stitch, then joining them together at the top. Although you can use most of the basic stitches to make a puff stitch, you get the best results from the taller stitches, such as double crochet and triple crochet.

- ✓ **Bobble:** The bobble creates a similar look to the puff stitch, but instead of working actual stitches, you use a series of loops to make it stand out.
- ✓ **Popcorn stitch:** This one really pops! It's a nicely rounded oval that stands out from the fabric, and you can make it "pop" to the front or the back of the fabric. It takes a bit more time but is well worth the effort. As with puff stitches and clusters, the taller stitches make more of an impact.

In most patterns, you won't use these stitches across every stitch and every row. Textured stitches, such as the bobble and the popcorn stitch, need a plain background for contrast. In other cases, because the stitch either increases or decreases the total number of stitches, you'll need to make up that difference elsewhere in the row to keep your rows even. For example, with a shell stitch, you work multiple stitches in the same stitch. To maintain your rows, you'll need to skip a few stitches before working the next shell stitch. With a cluster, the exact opposite is true. In fact, it's not uncommon to see stitch patterns made from equal numbers of shell stitches and clusters.

## *Change Is Good: Adding New Yarn*

At one point or another, you're going to have to add another skein of yarn. You will simply run out of the one you're working with, or you will need to change colors. Don't be tempted to tie a little knot between the two skeins and continue to crochet it into the fabric. It may look secure, but the knot will find its way to the front of your lovely project, and it may even unravel. Take some time to use the proper technique.

### *Making the switch at the beginning or end: It's all the same*

Many patterns call for you to change colors at the beginning of a row. In other cases, you may get to the end of a row and realize you don't have enough yarn left in the skein to get a good start on the next row, so you decide to go ahead and start a new skein. The beginning of one row or round is the end of the previous one, so we're pretty much talking about the same spot here. The following steps walk you through the correct way to join a new color at the beginning of a row of double crochet.

1. **Work the last double crochet stitch of the row to the point where there are 2 loops left on the hook.**
2. **Drop the first yarn color and pick up the second yarn color.**
3. **Wrap the end of the second yarn color around the hook as you would during any double crochet stitch. Be sure to leave at least a 6-inch tail from the new yarn.**
4. **Draw the second yarn color through the 2 loops of the first yarn color that are on your hook (see Figure 4-2).**

If you plan to pick up the first color in a later row, leave the yarn hanging and continue with the second color.

5. **Tug on the end of the first color to tighten up the stitch.**
6. **Continue crocheting across the row or round with the second color.**



**Figure 4-2:**  
Join yarn at  
the end of a  
row by  
drawing the  
new yarn  
through 2  
loops on  
your hook.

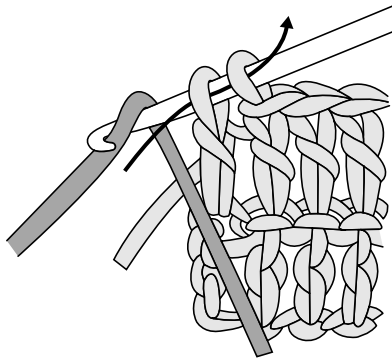

When you join a new color or skein of yarn and need to hide the end of the old color or skein, lay the loose end across the tops of the stitches in the previous row and work over it. This will save you time because you won't have to weave in the ends when you're finished.

## Midstream changes

At one time or another, you'll invariably run out of yarn in the middle of a row or round and have to add a new ball of yarn. Or maybe you're working a charted pattern that requires color changes in different places across the row. Either way, you need to be able to effect this change without making it seem obvious.

If you're just adding a new ball of the same color, you want to hide the ends and create a smooth transition without any lumps or bumps. If you're changing colors altogether, the most important thing is to prevent *color drag*. This is when the first color sort of bleeds into the second color, and you have a two-toned stitch. By changing yarns correctly, you can avoid this, and your pattern will move along smoothly.

The concept of changing colors midstream is basically the same as when you change colors at the beginning of a row (see the previous section). To add a new color in the middle of a row working in double crochet stitches, follow these steps:

1. **Work the last stitch prior to the stitch where you're going to make the color change up to the point where there are only 2 loops left on the hook.**
2. **Drop the first color yarn to the wrong side of your work and pick up the second color.**
3. **Wrap the end of the second color around the hook, getting set to complete the stitch.**
4. **Draw the second yarn color through the 2 remaining loops of the first color on your hook, completing the stitch with the second color (see Figure 4-3a).**
5. **Continue to work with the new color (see Figure 4-3b).**



If you're not going to need the first color yarn again, or at least not for a few more rows, cut the yarn, leaving a tail several inches long. Draw the tail end through the current stitch and work over the tail to hide it. You can also weave it in later with a yarn needle if that's your preference.

**Figure 4-3:**  
Join new  
yarn in the  
middle of a  
row from  
the wrong  
side of the  
fabric.

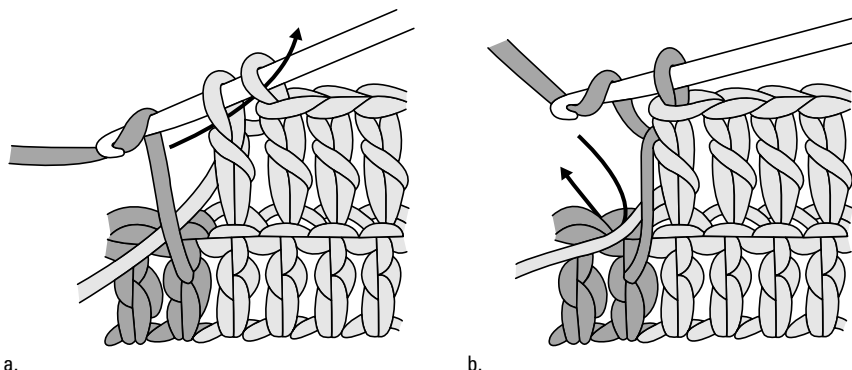

## Hold on tight! Carrying your yarn

If you've done any crocheting at all, you know that one of the most tedious aspects of crochet is weaving in a million little ends of yarn when you finally complete your design. One technique crocheters use quite often when working with two or more colors is to carry the yarn as they go. You can accomplish this through several different methods, each appropriate for particular projects:



- ✔ **Carry the yarn across the wrong side of your work:** This is probably the easiest method when working with several colors, and it's ideal for items that have a hidden "wrong side," such as a sweater, hat, or bag. To do this, simply work over the strand every few stitches, making sure that the carried strand appears on the wrong side of your work (see Figure 4-4).

If you're working a vertical stripe pattern and will be switching back and forth between colors frequently, carry the strand all the way across the row. However, if you're working a charted pattern and the picture is in the middle of the design, when you're done using the color in that row, drop the color to the wrong side and pick it back up on the return trip. That way you don't have to lug it with you all the way across.

- ✔ **Carry the yarn across the right side of your work:** There's really no reason to do this unless the design specifically calls for it. For instance, if the project includes adding a strand of tiny mirrors or sparkling sequins to your work, you would carry the strand across the right side because these are almost impossible to crochet with. You'd carry the yarn the same way as you would on the wrong side, but with the carried strand visible on the right side of the work.

**Figure 4-4:**  
Carrying  
yarn on the  
wrong  
side of your  
project.

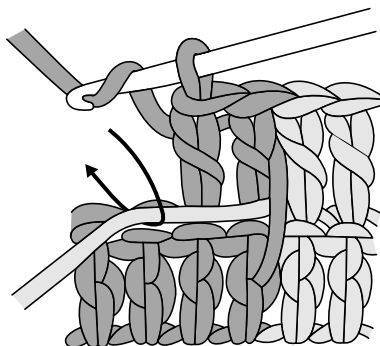

- ✔ **Working over the strand:** This hides the carried strand of yarn completely and is ideal for reversible items, such as shawls, scarves, and throws. Working over the yarn is similar to hiding the tail end of your yarn when you fasten off. Lay the unused strand of yarn across the tops of the stitches in the previous row and work your stitches over it, encasing it completely (see Figure 4-5). When you're ready to use it again, simply bring it out of hiding.
- ✔ **Carrying the yarn up the side of your work:** This works great if you're crocheting a horizontal stripe pattern that changes colors on even-numbered rows (if it changes on odd numbers, the color you need will be on the wrong end of the row). For projects with seams up both sides, any visible strands of yarn will be hidden in the seams. This is also a great technique when working with scarves or blankets that will have an edging crocheted later, because the edging will hide any stranding.

To carry the yarn up the side, follow these steps:

1. **Work two rows in the first color of your choice, switching to the second color in the last stitch of the second row.**
2. **Work two rows using the second color.**
3. **Draw up the first color from two rows below, completing the last stitch of the second row with the first color. Drop the second color to be picked up again two rows later (see Figure 4-6).**

**Figure 4-5:**  
You can  
hide your  
carried yarn  
by working  
over the  
strand.

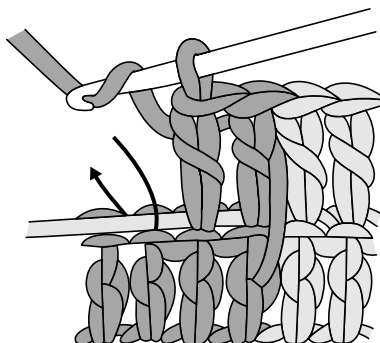

**Figure 4-6:**  
Drop the  
yarn, then  
pick it up  
two rows  
later to  
carry yarn  
up the side  
of a project.

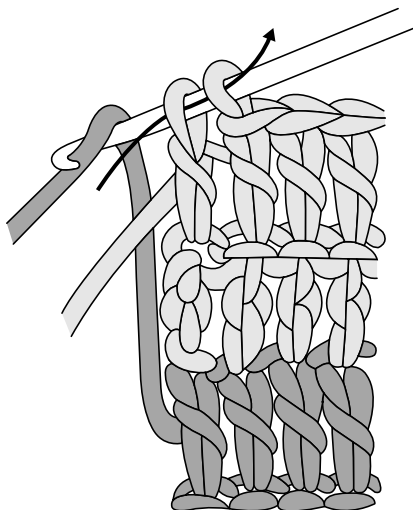



Don't pull the side strand too tightly, or you'll pull the rest of the work with it, and the side will pucker.

## *Weave it to the end*

At the very end of your project, you can handle any ends of yarn by sewing them into the fabric securely. This is called *weaving*. You typically weave in ends after any seams or edgings are completed but before you block the piece. Here's how to weave an end:

1. **Thread your yarn needle with an end.**
2. **Use your needle to weave the yarn through the center of the stitches for at least 2 inches in one direction.**
3. **Double back and sew at least 2 inches in the opposite direction.**
4. **Snip the tail of the end close to the last woven part, so it's hidden by the crochet.**

When weaving ends, really consider the best place to hide those ends. If you're working a lacy and open design, it's easiest to try to sew all the ends close to the edge of the work. Any additional bulk will become part of the edge and not disrupt the pattern. For solid patterns, it's sometimes easiest to sew the ends underneath the stitches on the row above, similar to if you carried the yarn along the tops of those stitches.

There aren't any hard and fast rules on the best places to weave ends. Use your judgment, check both sides of the fabric to ensure ends aren't showing, and weave in longer lengths than you feel you need to. Worse case scenario: If the ends become unwoven someday, you'll have enough yarn to sew them in again.



I really urge you to work over yarn ends as you crochet (see the "Making the switch at the beginning or end: It's all the same" section). Doing so allows you to avoid spending a lot of time weaving in yarn.

## *The Ins and Outs of Increasing and Decreasing Stitches*

Crochet just wouldn't be the same if you couldn't add some shape to it, and to do this, you simply add or subtract stitches across the row or around the round. Increasing or decreasing stitches is easy, and there are a few different methods of each. Read on for the specific how-to's.



When increasing or decreasing your stitches, always count how many stitches you have when you're done. The pattern will specify how many you should have at the end of the row.

### *Expanding rows by adding stitches*

*Increasing* (adding more stitches to a row than the previous row had) can be done anywhere across the row or in the round. Depending on the shape you're trying to achieve, you can increase at the beginning and end of a row, in the middle, in every stitch across the row or round, or in even increments. But, regardless of where the increase takes place, it's always accomplished by working two or more stitches into a single stitch.

The following steps walk you through a double crochet increase at the beginning of a row:

1. **Chain 3 (turning chain and first dc) (see Figure 4-7a).**
2. **Work your next stitch into the first stitch of the row immediately below the turning chain (see Figure 4-7b).**

Typically, because the turning chain counts as the first double crochet, you would skip this stitch and work into the next stitch.

**Figure 4-7:**  
Increasing  
with a  
double cro-  
chet stitch  
at the  
beginning  
of a row.

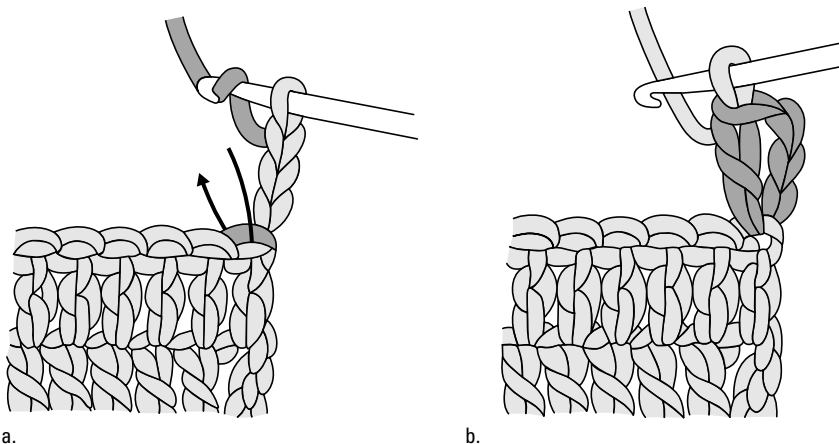

3. **Crochet across the rest of the row as you normally would, working one stitch into each stitch across.**

To increase any stitch at the beginning of a row, you follow the same steps, adjusting the turning chain accordingly. For a single crochet increase, you would chain 1, then work two complete single crochet stitches into the first stitch. For a triple crochet, you would chain 4, then work a triple crochet stitch into the first stitch of the row.

To increase a stitch at the end of the row, simply work two of the same stitches into the last stitch; to increase somewhere in the middle of a row, simply work two of the same stitches in the designated stitch of the row. Increasing in a round is a little different. I cover that technique in the “You’ll Come Around: Crocheting in Circles” section later in this chapter.

## *Shortening your rows with dwindling numbers*

Just as you can add stitches to a row or round, you can subtract, or *decrease*, the number of stitches. Decreasing stitches can take place anywhere an increase can: at the beginning and end of a row, or somewhere in the middle.

Decreasing stitches involves a few more steps than increasing, but it’s still easy. You can do your decrease in one of two ways:

- ✓ Turning two stitches into one
- ✓ Eliminating stitches altogether

*When two become one*

When you decrease a stitch, you work 1 stitch over 2 stitches in the previous row. It's a two-step process in which you do only half the stitch before starting a new stitch in the next stitch, and completing the decrease there. So you need to be ready to make a decrease before the last stitch of the row. The following steps show you how to turn two double crochet stitches into one:

1. Yarn over (yo), and insert your hook into the next stitch.
2. Yarn over, and draw the yarn through the stitch.
3. Yarn over, and draw the yarn through the first 2 loops on the hook (see Figure 4-8).

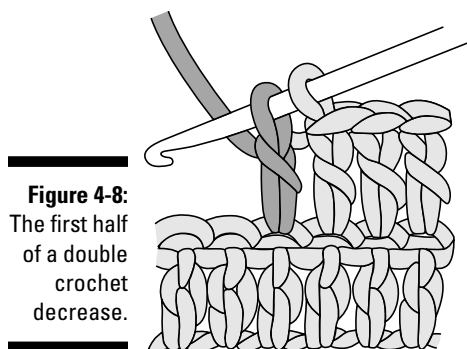

**Figure 4-8:**  
The first half  
of a double  
crochet  
decrease.

To begin the second half of the decrease, with the 2 loops still on your hook:

4. Yarn over, and insert your hook into the next stitch (see Figure 4-9).

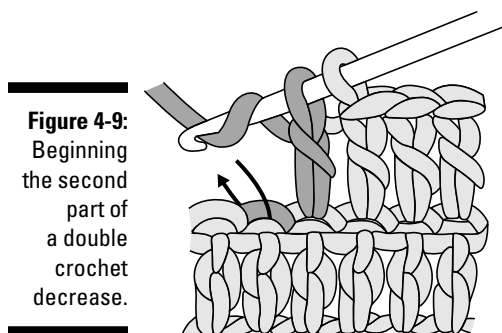

**Figure 4-9:**  
Beginning  
the second  
part of  
a double  
crochet  
decrease.

5. Yarn over, and draw the yarn through the stitch.
6. Yarn over, and draw the yarn through the first 2 loops on the hook (3 loops remain).
7. Yarn over, and draw the yarn through all 3 loops on the hook (see Figure 4-10a).

One double crochet decrease is now complete (see Figure 4-10b).



To decrease a stitch at the beginning of a row where a turning chain is involved, make the turning chain 1 stitch shorter than is normally called for. For example, a triple crochet stitch has a turning chain of 4 stitches; when you want to decrease it, chain 3 and then continue across the row as normal. When you return in the next row, don't work a stitch into the shortened chain.

**Figure 4-10:**  
Finishing  
a double  
crochet  
decrease.

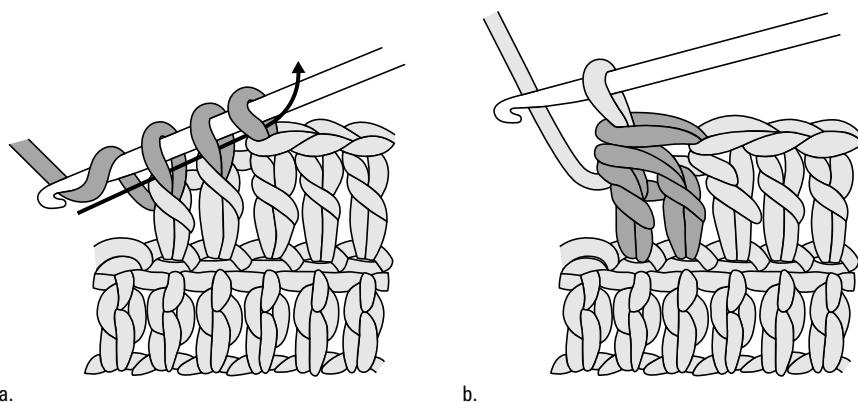

Decreasing other stitches is pretty much the same process. You work through the stitches to the last step, and then join them together by drawing your last yarn over through the remaining loops on your hook. Most patterns give you detailed steps on how the decreases should be made, so you won't feel like you're left in a lurch.

### *Skipping stitches*

The second and easiest way to decrease your stitches is, simply, not to make them. At the beginning of a row, you slip stitch across the specified number of stitches to the starting point, make your turning chain, and then proceed across the row. When you've worked the indicated number of stitches, you just stop crocheting and leave the specified number of stitches unworked. You then turn your work around and go back the way you came.

## *You'll Come Around: Crocheting in Circles*

Round designs are just as much a part of crochet as squares or rectangles. You work the stitches the same as if you were working in rows; how you begin the pattern dictates what shape it will become. *Working in rounds*, as it's called, has you going in circles instead of back and forth. The number of stitches increases with each round, usually in standard increments to ensure an even shape. You keep increasing the number of stitches in rounds until you reach the desired circumference. At this point, you may be done, as in the case of a doily or motif. But in some cases, you'll start working the same number of stitches in each round, as you would when crocheting a hat, or you'll decrease your stitches to create a ball shape.

### *Crafting the center ring*

To work in rounds, you must have a *center ring*. You typically make a center ring by crocheting several chain stitches and then joining them together with a slip stitch to form a circle. Sometimes you'll start crocheting in the round by working into a single chain stitch, but you won't see that as often.

To create a center ring, follow these steps:

1. **Chain 6.**
2. **Insert your hook into the first chain stitch made, forming a ring (see Figure 4-11a).**

**Figure 4-11:**  
Creating a  
center ring  
from a  
chain.

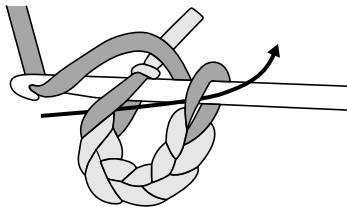

a.

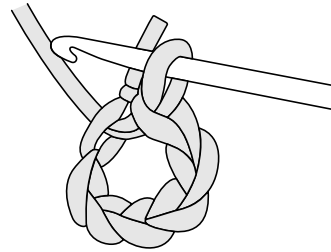

b.

### 3. Yarn over (yo).

4. Draw the yarn through the stitch and through the loop on your hook, as shown in Figure 4-11b. This makes a slip stitch to the beginning of the chain.



The number of chain stitches that make up the center ring determines how big the hole will be and how many stitches you can fit into it. The pattern you're working will tell you how many chain stitches to make when creating the center ring.

## Making the first round

After the center ring is complete, you can start working stitches into it. This is the first round. As with rows, you have to make a turning chain to bring your work up to the height of the stitches you'll be crocheting. The great thing about working into a center ring is this — you don't have to actually work into the chain stitches, just slip your hook through the hole in the center.

The following steps show you how to work your first round of single crochet stitches:

1. Chain 1 (turning chain for single crochet), and insert your hook into the center ring (see Figure 4-12a).
2. Yarn over (yo), and draw the yarn through the center ring.
3. Yarn over, and draw the yarn through the 2 loops on your hook (see Figure 4-12b).

Continue working single crochet stitches into the center ring until you can't fit any more. You'll be surprised at how many you can squeeze in there. When working a pattern, though, it will specify how many stitches to make.

**Figure 4-12:**  
Working  
single  
crochet  
stitches  
in the  
center ring.

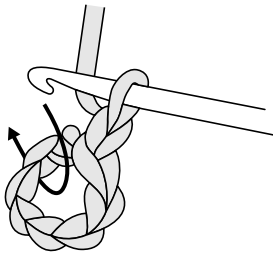

a.

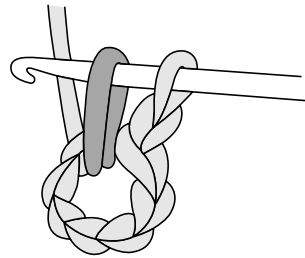

b.



## Joining ends

When you've crocheted the specified number of stitches into the center ring, it's time to move up and on, but you have to somehow bring the stitches together. To do this, you once again bring into play that invaluable little stitch, the slip stitch. Insert your hook into the top of the first stitch you made in the round and work a slip stitch (see Figure 4-13). This joins the round, and you're ready to move on to the next one.

**Figure 4-13:**  
Joining  
a single  
crochet  
round with a  
slip stitch.

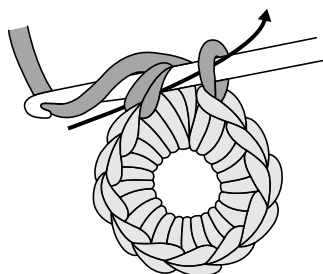

## Branching out

After joining the round, you need to chain the required number of turning chains for the next stitch, and then proceed with the instructions provided. To make sure the piece gets larger while staying flat, increases are typically worked in a regular sequence, based more or less on the number of stitches in the first round. Table 4-2 shows this increase pattern. For example, if you start with 8 stitches, each subsequent round needs to increase by 8 stitches so it stays flat and doesn't ruffle at the edges. However, be sure to read the instructions: Don't assume you'll always increase based on the number of stitches in the first round.

**Table 4-2** Increasing Stitches in Rounds

<i>Round Number</i>	<i>Number of Stitches in Round</i>			<i>How to Work the Increase</i>
Rnd 1	6	8	12	N/A
Rnd 2	12	16	24	Inc 1 stitch in each stitch around
Rnd 3	18	24	36	Inc 1 stitch in every other stitch around
Rnd 4	24	32	48	Inc 1 stitch in every 3rd stitch around
Rnd 5	30	40	60	Inc 1 stitch in every 4th stitch around
Rnd 6	36	48	72	Inc 1 stitch in every 5th stitch around



Most times you won't turn your piece after completing each round as you do with rows. Not turning your work gives it a definite front and back. If you want a piece that's reversible, turn your work after each round. The instructions in the pattern you're working will tell you how and where to do this.

## *Just keep going: Spirals*

Not all rounds are joined when you reach the end, and this method is called *working in a spiral*. You work in a spiral when you don't want to have a visible seam anywhere, usually with three-dimensional designs such as hats, bags, and toys. If you've mastered the single crochet stitch and nothing more complicated, you can crochet in a spiral because spirals typically use only the single crochet stitch. Taller stitches worked in this fashion tend to look uneven and out of shape.

To work a spiral, instead of joining the round when you get to the end, you simply work into the next stitch, which is the first stitch of the last round. Because the last stitch of the last round worked in a spiral will be raised, you have to join it to the previous round to smooth out the edge. Slip stitch into the first stitch of the previous round and fasten off.



Use a stitch marker and always mark the first stitch of each round. You'd be amazed at how easy it is to lose track of where you are and how many stitches you've worked. It's always a shame to have to tear out your work.

## *Creating shapes*

To make a round shape get bigger, you keep adding stitches. To shape it, you can either stop increasing and/or decrease your stitches. Many items such as hats, bags, socks, and mittens, start out by crocheting rounds. You shape them by changing the number of stitches.

To make a hat, you start out by increasing rounds until you reach the desired circumference, then you stop adding stitches and work even on the number of stitches that you already have. This causes the flat round piece that you have to curve upward, and there you have it — a new shape.

If you need to decrease your stitches, you work them the same way as you do when working in rows (see the "Shortening your rows with dwindling numbers" section earlier in this chapter). The instructions in the pattern will tell you where to make the decreases. They're typically made in a regular sequence the same as increases are.

# Part II

# Hook, Yarn, Action!

# Crocheting Simple Projects

The 5<sup>th</sup> Wave

By Rich Tennant



“You’re right – I probably will be the only one on the dirt track circuit to own a carburetor cozy.”

## *In this part . . .*

**I**f you're feeling a bit rusty or are unsure of where your skill level lies, this is a great section to start with. It's packed full of projects designed to get your fingers moving. All the chapters in this part focus on the basic skills, broken down into specifics within each chapter.

You'll find one chapter that focuses on the basic stitches with little or no shaping or color changes. Another provides designs that all involve some sort of shaping, whether it's increasing, decreasing, or a combination of both. Try the projects in the chapter that has you going in circles for a change of pace, or if you need to try your hand at changing colors, there's one in here just for you.

Whatever your preference is, this is a great place to start creating new projects.

## Chapter 5

# Working in the First Dimension

---

### *In This Chapter*

- ▶ Getting started with a set of practical potholders
  - ▶ Creating the ever-popular headband
  - ▶ Setting the scene with a bold and fluffy scarf
  - ▶ Working up a wooly afghan
- 

**R**eady, set, go! The projects I provide in this chapter are all designed to get your fingers moving. There's nothing quite like the satisfaction you feel when you complete a project, and you can crochet all these projects relatively quickly.

The first three designs are made using mainly two stitches — the chain stitch and the single crochet — with the occasional slip stitch thrown in, but as you'll see, the results are very different. The last pattern uses most of the basic stitches — the chain stitch, single crochet, half double crochet, double crochet, and triple crochet — combined to create a simple, attractive pattern.

Whether you decide to make just one of these projects or you want to tackle all of them, you'll find that even with the most basic of stitches you can create fabulous designs.

## *Practical Potholders*

You can never have too many potholders. Worked in 100% cotton, they're easy to care for (just throw them in the washer and dryer), and the generous size and tight single crochet stitch pattern (see Figure 5-1) provides protection for your hands.

The “Materials and vital statistics” section provides yarn information for three different colored potholders, but feel free to make just one or as many as you need. Potholders also make wonderful housewarming or hostess gifts, and the yarn is available in dozens of colors to match any décor.



**Figure 5-1:**  
You'll reach  
for these  
handy  
potholders  
over and  
over.

## *Materials and vital statistics*

✓ **Yarn:** Lily “Sugar’n Cream” 4-ply worsted-weight yarn (100% cotton), Article #102001 for solids; Article #102002 for ombres (2.5 oz. [70 g], 120 yds [109 m] each ball for solids; 2 oz. [56 g], 95 yds [86 m] each ball for ombres): 1 ball each of

- #18083 Cornflower
- #18015 Wine
- #19178 Potpourri Print

Each ball makes several potholders.

✓ **Hook:** Crochet hook size I-9 U.S. or size needed to obtain gauge (refer to Chapter 2 for more information on gauge)

✓ **Measurements:** 7¼ in. wide x 7¼ in. long

✓ **Gauge:** 11 sts and 13 rows sc = 3 in.

✓ **Stitches used:** Chain stitch (ch), slip stitch (sl st), single crochet (sc)

This is a great project to check for uniformity of stitches. The smooth yarn and simple pattern make it easy to see your stitches and ensure that you're working them evenly.

## *Directions*

**Foundation chain:** Ch 26.

**Row 1 (right side):** Sc in 2nd ch from hook, sc in each ch across (25 sc), *turn*.

**Rows 2–29:** Ch 1, sc in each sc across (25 sc), *turn*.

**Row 30:** Ch 1, sc in each sc across (25 sc), *do not turn*.

**Edging:** Working across side edge of potholder, work 1 sc in each row-end st across to next corner, work 3 sc in corner st, sc in each ch across opposite side of foundation chain to next corner, work 3 sc in corner st, working across next side edge, work 1 sc in each row-end st across to next corner.

**Finishing:** To make the hanging loop, ch 10, sl st in next sc to join, forming a loop. Fasten off.

## *Variation: Doubling the thickness*

If you'd like to make a heavier-weight potholder, make two potholders, omitting the edging. When both are complete, put the wrong sides together, matching stitches, and crochet the edging through the double thickness of both potholders.

## *Variation: Pumping up the size*

To make a larger potholder, increase the number of chain stitches in the foundation row until it reaches the desired width. Then increase the numbers of rows worked accordingly so the potholder forms a square.

## *Handy Headbands*

Whether you're young, old, or somewhere in between, and whether you wear your hair long or short, invariably you find yourself rooting through the drawers for a headband at one time or another. These days, they're a popular fashion accessory, but they're also great for keeping your hair out of your face when you're working out or cleaning the house. Crocheted using single crochet stitches, the resulting fabric is slightly stretchy, which allows for a little "head room" (see Figure 5-2).

The yarn information provided in the "Materials and vital statistics" section showcases three different types of yarn — "Trellis," "Incredible," and "Microspun" — with one ball or skein having enough yarn to make several headbands. After your family and friends see them, you're sure to get requests for more.



**Figure 5-2:**  
You can  
create  
headbands  
in different  
colors and  
textures.

## *Materials and vital statistics*

### ✓ **Yarn:**

- Lion Brand Yarn “Trellis” bulky-weight ribbon yarn (100% nylon), Article #500 (1.75 oz. [50 g], 115 yds [105 m] each ball): 1 ball of #302 Ocean
- Lion Brand Yarn “Incredible” bulky-weight ribbon yarn (100% nylon), Article #520 (1.75 oz. [50 g], 110 yds [100 m] each ball): 1 ball of #205 Carnival
- Lion Brand Yarn “Microspun” sport-weight yarn (100% microfiber acrylic), Article #910 (2.5 oz. [70 g], 168 yds [154 m] each skein): 1 skein of #109 Royal Blue

Each ball makes several headbands.

✓ **Hook:** Crochet hook size H-8 U.S. or size needed to obtain gauge (refer to Chapter 2 for more information on gauge)

✓ **Tapestry needle**

✓ **Measurements:** 1¾ in. wide x 18 in. in circumference

✓ **Gauge:** 5 sts and 5 rows sc = 1 in.

✓ **Stitches used:** Chain stitch (ch), single crochet (sc)

This pattern uses only two stitches to create the design. You crochet a short foundation chain, then work rows of single crochet stitches until the piece reaches the specified length. Sew the ends together when you’re done crocheting, and you’ve got a great accessory.



## Directions



The yarns “Trellis” and “Incredible” are part of the hot new family of fashion yarns. When crocheting with them, you may have difficulty at first because of the texture, but don’t give up. Take your time, and you’ll soon get used to their look and feel. If you’re a little uncomfortable with the textured yarns, start out with the “Microspun” and then pick up the others and give it a whirl.

**Foundation chain:** Ch 9.

**Row 1 (right side):** Sc in 2nd ch from hook, sc in each ch across (8 sc), *turn*.

**Row 2:** Ch 1, sc in each sc across (8 sc), *turn*.

Repeat Row 2 until headband measures 18 in. or fits the circumference of your head (or the recipient’s head if you’re giving it to someone else). Fasten off, leaving a sewing length of about 10 in.

**Finishing:** With the right sides of the headband facing, line up the stitches across from each other, and using the whipstitch (see Appendix A for directions on this stitch), sew the last row to the foundation chain by using the tapestry needle and sewing length.

## A Smart Scarf

This scarf really pops — and no one will believe how simple it is to make! Crocheted with loosely worked single crochet stitches (see Figure 5-3), the pattern is revealed as the yarn rolls out. With the onslaught of new yarns available, creating spectacular-looking designs without having to be an expert is easier than ever, as this project shows. Grab your hook and yarn, and jump right in!

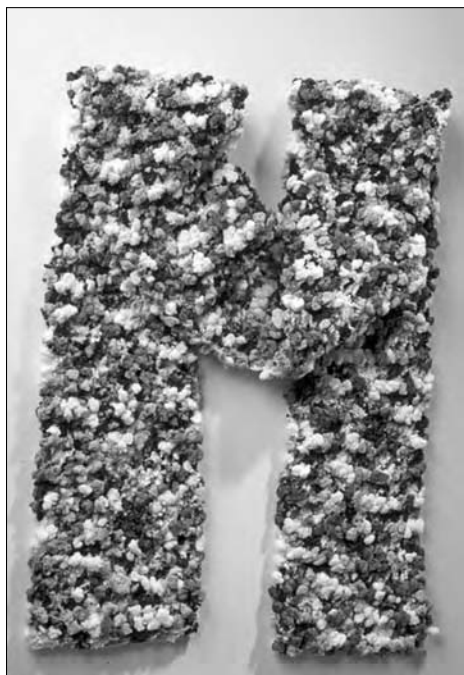

**Figure 5-3:**  
Keep the secret simplicity of this scarf to yourself.

## Materials and vital statistics

- ✓ **Yarn:** Patons “CiCi” super-bulky-weight yarn (68% acrylic/32% nylon), Article #241064 (1.75 oz. [50 g], 37 yds [33 m] each skein): 5 skeins of #64040 Starry Night
- ✓ **Hook:** Crochet hook size M-13 U.S. or size needed to obtain gauge (refer to Chapter 2 for more information on gauge)
- ✓ **Measurements:** 6 in. wide x 62½ in. long
- ✓ **Gauge:** 6 sts and 6 rows sc = 3 in.
- ✓ **Stitches used:** Chain stitch (ch), single crochet (sc)

This pattern only requires you to work two different stitches: the chain stitch for the foundation chain, then the single crochet stitch for the body of the scarf. You’ll work the single crochet stitches back and forth until you reach the desired length, and at certain points, you’ll run out of yarn and have to join a new skein. If you need a memory boost on how to do this correctly, please see Chapter 4.

## Directions



This yarn is an unconventional fashion yarn, but it really creates a fabulous fabric. Make sure to keep your stitches loose, and the bumps and lumps will pull right through.

**Foundation chain:** Ch 13.

**Row 1:** Sc in 2nd ch from hook, sc in each ch across (12 sc), *turn*.

**Row 2:** Ch 1, sc in each sc across (12 sc), *turn*.

Repeat Row 2 until scarf measures 62½ in. or desired length. Fasten off.

## Woolly Warmer Afghan

You can use this afghan on those really cold nights when you want to curl up with a soft, warm blanket and forget about the outside temperature (see Figure 5-4). The pattern uses most of the basic stitches and is worked vertically, or lengthwise, rather than in the traditional side-to-side manner. The yarn is a super-bulky-weight wool blend, which allows you to work it up faster than you could using a worsted-weight yarn (see Chapter 1 for more on yarns). Throw this afghan over the back of the sofa, or fold it at the foot of your bed, ready to provide an extra layer of warmth.



**Figure 5-4:**  
The wooly warmer afghan will protect you from winter's chill.

## *Materials and vital statistics*

- ✓ **Yarn:** Lion Brand Yarn “Wool-Ease Thick & Quick” super-bulky-weight yarn (80% acrylic/20% wool), Article #640 (6 oz. [170 g], 106 yds [97 m] each skein): 13 skeins of #143 Claret
- ✓ **Hook:** Crochet hook size M-13 U.S. or size needed to obtain gauge (refer to Chapter 2 for more information on gauge)
- ✓ **Measurements:** 50½ in. wide x 76 in. long
- ✓ **Gauge:** 6 sts = 4 in.; 5 rows in pat = 4 in.
- ✓ **Stitches used:** Chain stitch (ch), single crochet (sc), half double crochet (hdc), double crochet (dc), triple crochet (tr)

Because this afghan is worked in long rows, it's a great project to work on when you can sit yourself down in a comfortable chair or on the sofa. After you get a few rows finished, you'll find that the afghan gets somewhat awkward to shift around, and the arms of the chair or seat cushions of the sofa make a great support tool. You'll also need to add new skeins of yarn regularly, so please refer to Chapter 4 for detailed instructions.



## Directions

The bulky nature of this yarn requires the use of a larger hook, so you may find that you have to adjust your hold on the hook. Keep your hands and stitches loose, and the afghan will be finished in no time.

**Foundation chain:** Ch 124 + 2 (first hdc).

**Row 1:** Hdc in 3rd ch from hook, hdc in each ch across (125 hdc), *turn*.

**Row 2:** Ch 1, sc in first hdc, • tr in next hdc, sc in next hdc •, rep from • to • across to within last 2 hdc, tr in next hdc, sc in turning ch (125 sts), *turn*.

**Row 3:** Ch 2 (first hdc), hdc in each st across (125 hdc), *turn*.

**Row 4:** Ch 3 (first dc), dc in each hdc across, dc in turning ch (125 dc), *turn*.

**Row 5:** Ch 2 (first hdc), hdc in each dc across, hdc in turning ch (125 hdc), *turn*.

**Rows 6–57:** Rep Rows 2–5 (13 times).

**Rows 58–59:** Rep Rows 2–3. Fasten off.

## Variation: Supersize it!

To make the afghan bigger, add stitches to your foundation chain until you reach the desired length. Just make sure you end with an odd number of stitches so the pattern in Row 2 works. Adjust the width by repeating Rows 2–5 as many times as you want, and be sure to buy extra skeins of yarn.

## Variation: Trying a different yarn

This company also makes a super-bulky-weight chenille yarn that would work well with this pattern. You can use the same size hook suggested in the original pattern.

## Chapter 6

# Expanding and Diminishing Dimensions: Adding Shape

---

### *In This Chapter*

- ▶ Adding shape to a playful belt
  - ▶ Expanding your skills with a soft and stylish shawl
  - ▶ Creating interest for your table with a diamond-shaped runner
  - ▶ Multiplying stitches to create a corkscrew-shaped scarf
- 

**I**f you try to imagine a world without shapes, it seems very boring, indeed. No shaping? No fun! Shaping is involved in most crochet designs, and this chapter gives you the opportunity to create some wonderful projects while getting used to both increasing and decreasing stitches.

Adding stitches to your work, or *increasing* (inc) as it's called, is really a simple process. You just work more than one stitch in a given stitch. The pattern you're crocheting will give you specific details on how and where to place these stitches. On the opposite end of the spectrum is to subtract stitches, or *decrease* (dec) them. This process is slightly more involved than increasing, but don't let that frighten you off. Again, the pattern will give you specific details on how to get rid of those unwanted stitches. For detailed info on both of these skills, refer to Chapter 4.

This chapter's projects range from using basic crochet stitches to working with a simple pattern. You can practice not only working the stitches, but reading the patterns themselves, which get more involved as the projects do. Look through the following patterns, grab your hook and yarn, and create your favorite design. (Flip to Chapter 3 if you want a refresher on how to read a pattern.)

## *Beaded-Fringe Belt*

Belts are all the rage, and this one is no exception. From the easy-to-create design to the color pink, this is one that you'll reach for often (see Figure 6-1). A few rows of increasing, a whole bunch of rows worked even, a few rows of decreasing, add some fringe and beads, then you're done! You'll have a new fashion accessory that you'll love to wear. (If you find it missing, check with the younger set in your household!)



**Figure 6-1:**  
Add a little  
interest to  
your outfits  
with the  
beaded-  
fringe belt.

## *Materials and vital statistics*

- ✓ **Size:** One size fits most adults
- ✓ **Yarn:** Coats & Clark “TLC Cotton Plus” worsted-weight yarn (51% cotton/49% acrylic), Article #E516 (3.5 oz. [100 g], 178 yds [163 m] each skein); 1 skein of #3706 Light Rose
- ✓ **Hook:** Crochet hook size H-8 U.S. or size needed to obtain gauge
- ✓ **Beads:**
  - 88 round, silver metal beads with large center holes (4 x 6mm)
  - 44 square, pink beads with large center holes (5mm)
- ✓ **Measurements:** 2¼ in. wide x 55¼ in. long, excluding fringe
- ✓ **Gauge:** 5 sts and 5 rows sc = 1 in.
- ✓ **Stitches used:** Chain stitch (ch), single crochet (sc). **Dec 1 sc:** • (Insert hook in next st, yo, draw yarn through st) twice, yo, draw yarn through 3 loops on hook •.

This design starts out with just a single stitch on the first end and increases stitches until you have all the stitches you need for the width of the belt. The chain-1 turning chain creates a pretty scalloped effect along the edge of the belt, which eliminates the need for edging. When you get close to the end, you decrease your stitches until, once again, you’re left with just a single stitch. You finish it off by adding some beaded fringe.

## *Working up one end and the length of the belt*

**Foundation chain:** Ch 2.

**Row 1:** Sc in 2nd ch from hook (1 sc), *turn*.

**Row 2:** Ch 1, 2 sc in sc (2 sc), *turn*.

**Row 3:** Ch 1, sc in each sc across (2 sc), *turn*.

**Row 4:** Ch 1, 2 sc in first sc, 2 sc in last sc (4 sc), *turn*.

**Row 5:** Ch 1, sc in each sc across (4 sc), *turn*.

**Row 6:** Ch 1, 2 sc in first sc, sc in each of next 2 sc, 2 sc in last sc (6 sc), *turn*.

**Row 7:** Ch 1, sc in each sc across (6 sc), *turn*.

**Row 8:** Ch 1, 2 sc in first sc, sc in each of next 4 sc, 2 sc in last sc (8 sc), *turn*.

**Row 9:** Ch 1, sc in each sc across (8 sc), *turn*.

**Row 10:** Ch 1, 2 sc in first sc, sc in each of next 6 sc, 2 sc in last sc (10 sc), *turn*.

**Row 11:** Ch 1, sc in each sc across (10 sc), *turn*.

Rep Row 11 until belt measures  $53\frac{1}{2}$  in., or  $1\frac{1}{4}$  in. less than desired length.

## *Beginning the other end*

**Row 1:** Ch 1, dec 1 sc in first 2 sc, sc in each of next 6 sc, dec 1 sc in last 2 sc (8 sc), *turn*.

**Row 2:** Ch 1, sc in each sc across (8 sc), *turn*.

**Row 3:** Ch 1, dec 1 sc in first 2 sc, sc in each of next 4 sc, dec 1 sc in last 2 sc (6 sc), *turn*.

**Row 4:** Ch 1, sc in each sc across (6 sc), *turn*.

**Row 5:** Ch 1, dec 1 sc in first 2 sc, sc in each of next 2 sc, dec 1 sc in last 2 sc (4 sc), *turn*.

**Row 6:** Ch 1, sc in each sc across (4 sc), *turn*.

**Row 7:** Ch 1, dec 1 sc in first 2 sc, dec 1 sc in last 2 sc (2 sc), *turn*.

**Row 8:** Ch 1, sc in each sc across (2 sc), *turn*.

**Row 9:** Ch 1, dec 1 sc in 2 sc (1 sc). Fasten off.

## Finishing with fringe

To make the fringe, cut yarn into 22 20-in. lengths. Using 1 strand of yarn for each fringe, starting at the bottom point of one end of the belt, single-knot one fringe in the bottom point, then in every other row across the side edges of the belt 5 times (the last fringe will be in the row where stitches are worked evenly and the shaping ends).



The fringe will be uneven — that is, it should be shaped like the point of the belt. If you prefer to have it straight across, simply trim the ends even before threading the beads. (See Appendix A for more on fringe.)

To attach the beads, thread one silver bead, one pink bead, then another silver bead onto each fringe, leaving enough length free to tie the yarn in a knot. Tie the end in an overhand knot to secure. The beads will then hang at the end of each fringe. Trim ends even.

## Variation: Adding some color or a jingle

For a change of pace, use a complementary shade of yarn for the fringe, or for a more exotic look, replace the beads on the fringe with tiny bells.

## Shades-of-Gray Shawl

This generously sized shawl gives you plenty of opportunity to hone your decreasing skills while at the same time creating a fabric reminiscent of tweed (see Figure 6-2). The simple black edging ties it all together, and when finished, you've created a versatile piece that you'll want to keep handy for whenever you're heading out the door.



**Figure 6-2:**  
The shades-of-gray shawl looks great with casual attire.



## Materials and vital statistics

- ✓ **Size:** One size fits most adults
- ✓ **Yarn:** Bernat “Soft Bouclé” bulky-weight yarn (98% Gentle Soft acrylic/2% polyester), Article #161026 (5 oz. [140 g], 255 yds [233 m] each skein):
  - 3 skeins of #26928 Grey Shades (MC)
  - 1 skein of #06756 Black (CC)
- ✓ **Hook:** Crochet hook size K-10½ U.S. or size needed to obtain gauge
- ✓ **Measurements:** 34½ in. from bottom point to top edge; 68½ in. across top edge
- ✓ **Gauge:** 10 sts and 10 rows hdc = 4 in.
- ✓ **Stitches used:** Chain stitch (ch), slip stitch (sl st), single crochet (sc), half double crochet (hdc). **Dec 1 hdc:** • Yo, (insert hook in next st, yo, draw yarn through st) twice, yo, draw yarn through 4 loops on hook •.



Working a decrease with the half double stitch is almost identical to the single crochet decrease. In fact, you only do one more step, and that’s the yarn over you do at the very beginning of the decrease.

This shawl is made from the top edge down. You start off with a long foundation chain, work a single row of half double crochet stitches to get started, then begin to decrease the number of stitches in each row until you get to the very end and there’s only one stitch left.

## Directions



Take note that the decreasing is worked in the second and third stitches at the beginning of a row and the second-to-last and third-to-last stitches at the end of the row, not the first two and last two stitches as you usually see. This method creates a smoother finish to the edge and doesn’t affect the way the decreasing looks.

**Foundation chain:** With MC, ch 167 + 2 (first hdc).

**Row 1 (right side):** Hdc in 3rd ch from hook, hdc in each ch across (168 hdc), *turn*.

**Row 2 (wrong side):** Ch 2 (first hdc), dec 1 hdc in next 2 hdc, hdc in each hdc across to within last 3 hdc, dec 1 hdc in next 2 hdc, hdc in top of turning ch (166 hdc), *turn*.

**Rows 3–84:** Ch 2 (first hdc), dec 1 hdc in next 2 hdc, hdc in each hdc across to within last 3 hdc, dec 1 hdc in next 2 hdc, hdc in top of turning ch (2 hdc at end of last row), *turn*.

**Row 85:** Dec 1 hdc in 2 hdc (1 hdc). Fasten off.

**Edging:** With right side facing, join CC in first hdc at top right-hand corner, ch 1, working across top edge of shawl, sc in first hdc, ch 1, • sc in next hdc, ch 1 •, rep from • to • across to next corner, (sc, ch 1, sc) in corner st, ch 1, working in row-end sts across side edge of shawl, rep from • to • across to next corner, (sc, ch 1, sc) in bottom point, ch 1, working in row-end sts across next side edge, rep from • to • across to top right-hand corner, (sc, ch 1, sc) in corner st, ch 1, sl st in first sc to join. Fasten off.

## Festive Diamond-Shaped Table Runner

This runner will certainly add some pizzazz to your table. The colors are bright, the cotton yarn is easy to care for, and the shape is unique (see Figure 6-3). In addition to all this, you get to practice increasing and decreasing while working a simple seed stitch pattern.

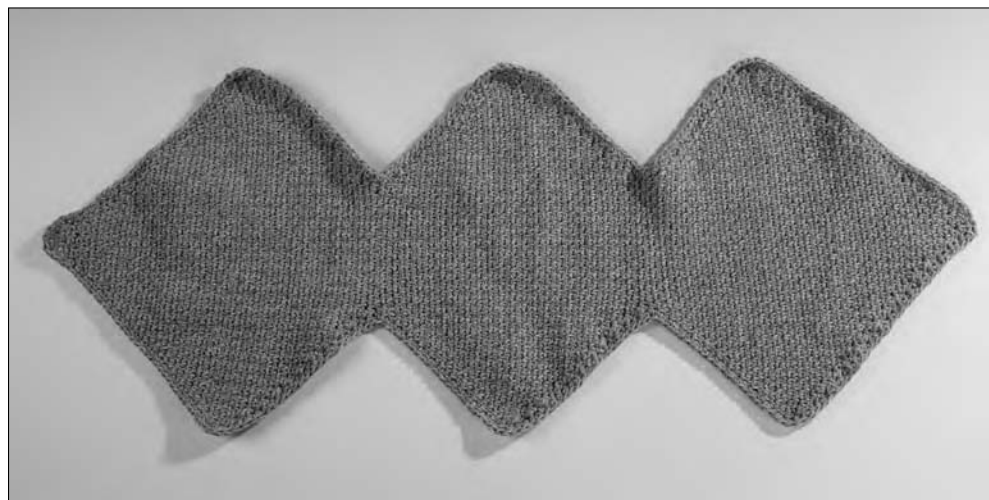

**Figure 6-3:**  
Dress up  
your table  
with this  
casual table  
runner.

This pattern is comprised of just the chain stitch and the single crochet. Don't be intimidated by the thought of working with a pattern — this one is really basic, and it'll get you in the groove.

### Materials and vital statistics

- ✓ **Yarn:** Aunt Lydia's "Quick Crochet" worsted-weight thread (75% cotton/25% acrylic), Article #174 (400 yds [366 m] each ball): 1 ball of #1004 Citrus
- ✓ **Hook:** Crochet hook size H-8 U.S. or size needed to obtain gauge
- ✓ **Measurements:** 13¼ in. wide x 30¼ in. long
- ✓ **Gauge:** 16 sts and 16 rows in pat = 3 in.
- ✓ **Stitches used:** Chain stitch (ch), slip stitch (sl st), single crochet (sc). **Dec 1 sc:** • (Insert hook in next st, yo, draw yarn through st) twice, yo, draw yarn through 3 loops on hook •.

This pattern is one that you'll see fairly regularly and is relatively simple as far as stitch patterns go. After you've got your foundation chain going, you work single crochet stitches into the spaces created by the chain stitches, then work chain stitches over the single crochet stitches to create the spaces for the next row. Be sure to work a gauge swatch to get the hang of the pattern and your stitch sizes.



## Directions

When counting your stitches in this pattern, the first chain you make before working your single crochet stitch is your turning chain and not part of the stitch count for each row.

**Foundation chain:** Ch 4.

**Row 1:** Sc in 2nd ch from hook, ch 1, skip next ch, sc in last ch (3 sts), *turn*.

**Row 2:** Ch 1, (sc, ch 1) in first sc (inc made), sc in next ch-1 space, (ch 1, sc) in last sc (inc made) (5 sts), *turn*.

**Rows 3–34:** Ch 1, (sc, ch 1) in first sc (inc made), • sc in next ch-1 space, ch 1, skip next sc •, rep from • to • across to within last sc, sc in last sc (69 sts at end of last row), *turn*.

**Row 35:** Ch 1, dec 1 sc in first sc and ch-1 space, • ch 1, skip next sc, sc in next ch-1 space •, rep from • to • across to within last 2 sts, dec 1 sc in next ch-1 space and last sc (67 sts), *turn*.

**Rows 36–57:** Ch 1, dec 1 sc in first sc and ch-1 space, • ch 1, skip next sc, sc in next ch-1 space •, rep from • to • across to within last 2 sts, dec 1 sc in next ch-1 space and last sc (23 sts at end of last row), *turn*.

**Rows 58–80:** Ch 1, (sc, ch 1) in first sc (inc made), • sc in next ch-1 space, ch 1, skip next sc •, rep from • to • across to within last sc, sc in last sc (69 sts at end of last row), *turn*.

**Rows 81–103:** Ch 1, dec 1 sc in first sc and ch-1 space, • ch 1, skip next sc, sc in next ch-1 space •, rep from • to • across to within last 2 sts, dec 1 sc in next ch-1 space and last sc (23 sts at end of last row), *turn*.

**Rows 104–126:** Ch 1, (sc, ch 1) in first sc (inc made), • sc in next ch-1 space, ch 1, skip next sc •, rep from • to • across to within last sc, sc in last sc (69 sts at end of last row), *turn*.

**Rows 127–159:** Ch 1, dec 1 sc in first sc and ch-1 space, • ch 1, skip next sc, sc in next ch-1 space •, rep from • to • across to within last 2 sts, dec 1 sc in next ch-1 space and last sc (3 sts at end of last row), *turn*. Do not fasten off.

**Edging:** Ch 1, sc in each st around entire outside edge of runner, sl st in first sc to join. Fasten off.

## Variation: Giving it some shine, or adding a detail

To dress up the runner a little bit, try using a worsted-weight metallic thread (great for a holiday look). Or for some added fun, add a tassel to each end. (See Appendix A for tassel how-to's.)

## Curlicue Scarf

Scarves are one of the must-have fashion accessories these days, not just something you wear to keep your neck warm. You can make just about any type of scarf: big, fat, fluffy scarves; really, really long scarves; skinny, silky scarves; and everything in between. This pattern falls into the in-between category because it curls around and around for its entire length (see Figure 6-4). You make the scarf curl just by increasing stitches at regular intervals along the foundation chain's length.



**Figure 6-4:** Add pizzazz with this great curlicue scarf.

### Materials and vital statistics

- ✓ **Yarn:** Muench Yarns “Oceana” worsted-weight yarn (55% viscose/30% nylon/15% cotton), Article #M480 (1.75 oz. [50 g], 77 yds [70 m] each ball): 3 balls of #4808 blue multi
- ✓ **Hook:** Crochet hook size K-10½ U.S. or size needed to obtain gauge
- ✓ **Measurements:** 3 in. wide x 56 in. long
- ✓ **Gauge:** 6 sts in pat = 2 in.; first 2 rnds = 1½ in.
- ✓ **Stitches used:** Chain stitch (ch), slip stitch (sl st), single crochet (sc), half double crochet (hdc), double crochet (dc)

This pattern showcases another type of increasing. Because you’re working across both sides of the foundation chain as opposed to just one side, it becomes a round instead of a row. By working two stitches into one, you make the piece curl, turning it into a loose spiral.

## *Directions*

**Foundation chain:** Ch 151.

**Rnd 1:** Sc in 2nd ch from hook, sc in each ch across to within last ch, 3 sc in last ch, working across opposite side of foundation ch, sc in each sc across to within last ch, 2 sc in last ch (302 sc), sl st in first sc to join.

**Rnd 2:** Ch 2 (first hdc), hdc in first sc, hdc in next sc, • 2 hdc in next sc, hdc in next sc •, rep from • to • around (453 hdc), sl st in first hdc to join.

**Rnd 3:** Ch 3 (first dc), dc in first hdc, dc in next hdc, • 2 dc in next hdc, dc in next hdc •, rep from • to • around to within last hdc, dc in last hdc (679 dc), sl st in first dc to join. Fasten off.

## *Variation: Shrinking the scarf*

You can use this pattern to create curly ribbons to wrap packages or tie your hair back with by using a smaller hook, thinner yarn, and a shorter foundation chain.



## Chapter 7

# Going in Circles: Crocheting in the Round

---

### *In This Chapter*

- ▶ Creating a denim-look flirty skirt
  - ▶ Using suede to crochet a newsboy beret
  - ▶ Designing a red velvet crusher hat
  - ▶ Combining circular techniques to make a drawstring bag
- 

**M**any crocheted pieces are worked back and forth in rows, but you can also create projects by working *in the round*. Crocheting in the round allows you to add shape to your designs that working in rows doesn't. You can use many different techniques, and this chapter highlights several of them.

In the first design, the denim-look skirt, you start off by joining your foundation chain and creating a large circle to work from. For the other three, you start with a more traditional center ring, but where you go from there makes the difference. Each one of the designs featured in this chapter allows you to get in some practice time with important crochet skills. (If you need a refresher on how crocheting in the round differs from crocheting in rows, turn to Chapter 4. And Chapter 2 contains a reminder of how to measure gauge in the round.)

## *Flirty Denim Skirt*

The denim skirt has been around for years, and with good reason. As with any pair of jeans, you can dress it up or dress it down and it still looks good. You use a denim-look yarn to create this skirt, which is designed to sit at the hip, rather than up around your waist. The drawstring at the waist allows you to adjust the fit, and the ruffles at the bottom give it a feminine edge (see Figure 7-1). Pair the skirt with a T-shirt or throw some leggings on underneath to get the look that's so popular today.

This skirt includes a combination of different construction skills for which it falls into the intermediate skill-level category, but don't let this intimidate you. The stitches are basic, and the instructions are easy to navigate. Many patterns are worked in this manner, and it's a great stepping stone to prepare you for more-advanced patterns.



The skirt is designed to be short, reaching to about mid-thigh, but if you prefer wearing something a bit longer, go ahead and keep crocheting until the length reaches one you're comfortable with. Remember, though, that if you go longer, you'll need extra yarn.

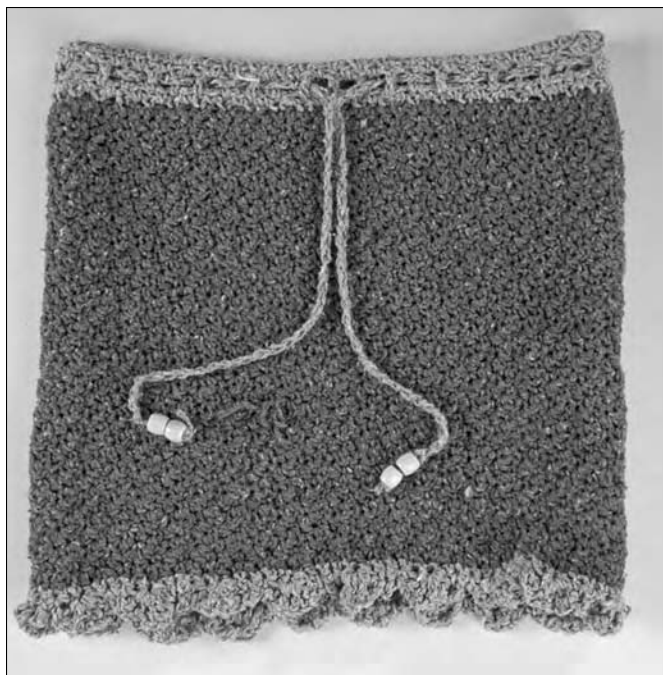
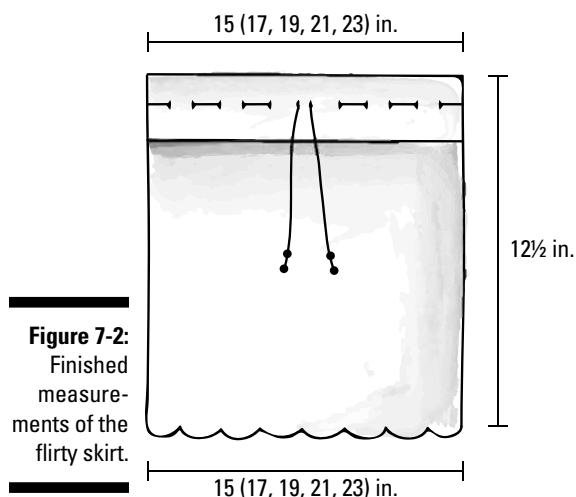

**Figure 7-1:**  
This crocheted denim-look skirt looks great paired with a casual top.

## Materials and vital statistics

- ✓ **Size:** Directions given are for size X-Small (2–4). Changes for Small (6–8), Medium (10–12), Large (14–16), and X-Large (18) are in parentheses. Finished hip: 30 (34, 38, 42, 46) in. Finished length: 12½ in. (See Figure 7-2.)
- ✓ **Yarn:** Rowan Yarns “Summer Tweed” worsted-weight yarn (70% silk/30% cotton), (1.75 oz. [50 g], 118 yds [108 m] each hank):
  - 3 (4, 4, 5, 5) hanks of #529 Denim (A) (If you’re making the skirt longer than the pattern calls for, you’ll need more of this color.)
  - 1 hank of #500 Powder (B)
  - 1 hank of #514 Reed (C)
- ✓ **Hook:** Crochet hook size I-9 U.S. or size needed to obtain gauge
- ✓ **4 8mm wooden beads**
- ✓ **Gauge:** 12 sts and 12 rows in pat = 4 in.
- ✓ **Stitches used:** Chain stitch (ch), slip stitch (sl st), single crochet (sc), double crochet (dc). **Shell:** • [(Dc, ch 1) 4 times, dc] in same stitch • **Picot:** • Ch 3, sl st in 3rd ch from hook •





The method used to start this skirt is somewhat different than you usually see, although it's not uncommon. Starting at the waist edge, you crochet a long foundation chain, and then join the ends with a slip stitch to form a circle. The body of the skirt is then worked in rounds from the waist down to the lower edge. The key here is not to twist the chain when joining the ends — it will create a tangled mess.

When you get to the waistband, Row 3 is called a *beading round*. This doesn't mean you add beads — it's a round worked with spaces between the stitches to allow you to weave a drawstring through.

## Building the skirt body

**Foundation chain:** Starting at waist edge, with A, ch 90 (102, 114, 126, 138) and without twisting ch, close into a ring with one sl st in first ch.

**Rnd 1:** Ch 1, sc in each ch around (90 [102, 114, 126, 138] sc), sl st in first sc to join, *turn*.

**Rnd 2:** Ch 3 (first dc), sc in next sc, • dc in next sc, sc in next sc •, rep from • to • around (90 [102, 114, 126, 138] sts), sl st in first dc to join, *turn*.

**Rnd 3:** Ch 3 (first dc), sc in next dc, • dc in next sc, sc in next dc •, rep from • to • around (90 [102, 114, 126, 138] sts), sl st in first dc to join, *turn*.

Rep Row 3 for pat.

Work even in pat until skirt body reaches 11 in. from beg, or 1 in. less than desired length. Fasten off.

## *Adding the all-important waistband*

**Rnd 1:** With right side facing, join B in first st at waist edge of skirt, working across opposite side of foundation ch, ch 1, • sc in ch, ch 1, skip next ch •, rep from • to • around (45 [51, 57, 63, 69] ch-1 spaces), sl st in first sc to join, *turn*.

**Rnd 2:** Ch 1, • sc in ch-1 space, ch 1, skip next sc •, rep from • to • around (45 [51, 57, 63, 69] ch-1 spaces), sl st in first sc to join, *turn*.

**Rnd 3 (beading rnd):** Ch 3 (first dc), ch 1, skip next sc, • dc in next ch-1 space, ch 1, skip next sc •, rep from • to • around (45 [51, 57, 63, 69] ch-1 spaces), sl st in first dc to join, *turn*.

**Rnd 4:** Ch 1, • sc in ch-1 space, ch 1, skip next dc •, rep from • to • around (45 [51, 57, 63, 69] ch-1 spaces), sl st in first sc to join, *turn*.

**Rnd 5:** Rep Rnd 2. Fasten off.

## *Decorating the hem with a ruffle*

**Rnd 1:** With right side facing, join C in first st at bottom edge of skirt, ch 1, sc in each st around (90 [102, 114, 126, 138] sc), sl st in first sc to join, *turn*. Fasten off C, join B.

**Rnd 2:** Ch 3 (first dc), ch 1 (first ch-1 space), (dc, ch 1, dc) in first sc, • ch 1, skip next sc, sl st in next sc, picot, sl st in next sc, ch 1, skip next sc, shell in next sc •, rep from • to • evenly around bottom edge to within last 5 sts, ch 1, sl st in next sc, picot, sl st in next sc, ch 1, (dc, ch 1) twice in first sc, sl st in first dc to join. Fasten off.

## *Finishing with the drawstring tie*

To make the drawstring tie, use C to make a chain approx 12 in. longer than the finished hip measurement. Thread two beads onto each end of the chain and tie the ends into a knot to secure. Starting at the center front of the waistband, weave the drawstring over then under the stitches in Round 3 (beading round) of the waistband, leaving equal lengths on each side. Fold the waistband down toward the right side.

## *Coffee Suede Beret*

Okay, so how many years has this style of hat been around? Too long to remember, I'm sure. But like most good fashion statements, the beret has made a comeback (see Figure 7-3). You see them in all colors of the rainbow, from browns and blacks to bold, bright colors, and even pastels. The yarn used in this project has a remarkable resemblance to real suede, although it's much easier to care for.

This project is suitable for an intermediate-level crocheter because of the shaping involved and the construction of the brim. By following the instructions step by step, you'll see how, by increasing and decreasing your stitches, the form takes shape and realize that it's not so difficult after all.

**Figure 7-3:** The news-boy beret uses a common increasing and decreasing technique to create its shape.



## Materials and vital statistics

- ✓ **Size:** One size fits most adults
- ✓ **Yarn:** Lion Brand Yarn “Lion Suede” bulky-weight yarn (100% polyester), Article #210 (3 oz. [85 g], 122 yds [110 m] each skein): 3 skeins of #126 Coffee
- ✓ **Hook:** Crochet hook size I-9 U.S. or size needed to obtain gauge
- ✓ **Stitch markers**
- ✓ **Measurement:** 21 in. in circumference
- ✓ **Gauge:** First 7 rnds = 4 in.
- ✓ **Stitches used:** Chain stitch (ch), slip stitch (sl st), single crochet (sc).  
**Dec 1 sc:** • (Insert hook in next st, yo, draw yarn through st) twice, yo, draw yarn through 3 loops on hook • **Long single crochet (lsc):** Working over sc in current row, sc in sc 2 rows below.

In this instance, the center ring is created by crocheting the stitches for the first round into a single chain stitch. The hat itself is worked in a spiral to avoid creating seams, increasing your work, then decreasing back to the desired circumference. The brim, or visor, is made of two layers of single crochet stitches, which are then crocheted together along the edges to provide a firm front.

## Stitching in circles to create the beret



Use your stitch markers when crocheting this design. If you lose count during one of your rounds, it’s almost impossible to figure out where you started. Pulling out work and starting over is never fun.

**Foundation chain:** Ch 2.

**Rnd 1 (right side):** Work 6 sc in 2nd ch from hook (6 sc), do *not* join. Continue to work in a spiral, marking beg of each rnd, moving marker up as work progresses.

**Rnd 2:** 2 sc in each sc around (12 sc).

**Rnd 3:** • Sc in next sc, 2 sc in next sc •, rep from • to • around (18 sc).

**Rnd 4:** • Sc in each of next 2 sc, 2 sc in next sc •, rep from • to • around (24 sc).

**Rnd 5:** • Sc in each of next 3 sc, 2 sc in next sc •, rep from • to • around (30 sc).

**Rnd 6:** • Sc in each of next 4 sc, 2 sc in next sc •, rep from • to • around (36 sc).

**Rnd 7:** • Sc in each of next 5 sc, 2 sc in next sc •, rep from • to • around (42 sc).

**Rnd 8:** • Sc in each of next 6 sc, 2 sc in next sc •, rep from • to • around (48 sc).

**Rnd 9:** • Sc in each of next 7 sc, 2 sc in next sc •, rep from • to • around (54 sc).

**Rnd 10:** • Sc in each of next 8 sc, 2 sc in next sc •, rep from • to • around (60 sc).

**Rnd 11:** • Sc in each of next 9 sc, 2 sc in next sc •, rep from • to • around (66 sc).

**Rnd 12:** • Sc in each of next 10 sc, 2 sc in next sc •, rep from • to • around (72 sc).

**Rnd 13:** • Sc in each of next 11 sc, 2 sc in next sc •, rep from • to • around (78 sc).

**Rnd 14:** • Sc in each of next 12 sc, 2 sc in next sc •, rep from • to • around (84 sc).

**Rnd 15:** • Sc in each of next 13 sc, 2 sc in next sc •, rep from • to • around (90 sc).

**Rnd 16:** Sc in each of next 29 sc, (2 sc in next sc, sc in each of next 14 sc) twice, 2 sc in next sc, sc in each of next 30 sc (93 sc).

**Rnd 17:** Sc in each of next 29 sc, (2 sc in next sc, sc in each of next 15 sc) twice, 2 sc in next sc, sc in each of next 31 sc (96 sc).

**Rnds 18–19:** Sc in each sc around (96 sc).

**Rnd 20:** Sc in each of next 29 sc, (dec 1 sc in next 2 sc, sc in each of next 15 sc) twice, dec 1 sc in next 2 sc, sc in each of next 31 sc (93 sc).

**Rnd 21:** Sc in each of next 29 sc, (dec 1 sc in next 2 sc, sc in each of next 14 sc) twice, dec 1 sc in next 2 sc, sc in each of next 30 sc (90 sc).

**Rnd 22:** • Dec 1 sc in next 2 sc, sc in each of next 13 sc •, rep from • to • around (84 sc).

**Rnd 23:** • Dec 1 sc in next 2 sc, sc in each of next 12 sc •, rep from • to • around (78 sc).

**Rnd 24:** • Dec 1 sc in next 2 sc, sc in each of next 11 sc •, rep from • to • around (72 sc).

**Rnd 25:** • Dec 1 sc in next 2 sc, sc in each of next 10 sc •, rep from • to • around (66 sc).

**Rnds 26–27:** Sc in each sc around (66 sc).

**Rnd 28:** Sc in each sc around (66 sc), sl st in first sc to join. Fasten off.

## *Joining the visor as you craft it*

The visor is created by first making the bottom half, then crocheting the top half in exactly the same manner. The resulting look before you join the edges will be somewhat like a duck bill. The entire bottom edge of the hat is finished by working a round of stitches beginning at the center back of the hat and working around, joining the two loose edges of visor as you go.

### *Bottom*

**Row 1:** With right side facing, skip first 20 sc, join yarn in next sc, ch 1, work 1 lsc in sc, lsc in each of next 25 sc (26 lsc), *turn*.

**Row 2:** Ch 1, working in front loops of sts, sc in each of first 8 sc, (2 sc in next sc, sc in each of next 8 sc) twice (28 sc), *turn*.

**Row 3:** Ch 1, working in both loops of sts, dec 1 sc in first 2 sc, sc in each sc across to last 2 sc, dec 1 sc in last 2 sc (26 sc), *turn*.

**Row 4:** Ch 1, dec 1 sc in first 2 sc, sc in each of next 6 sc, 2 sc in next sc, sc in each of next 8 sc, 2 sc in next sc, sc in each of next 6 sc, dec 1 sc in last 2 sc (26 sc), *turn*.

**Row 5:** Ch 1, dec 1 sc in first 2 sc, sc in each sc across to last 2 sc, dec 1 sc in last 2 sc (24 sc), *turn*.

**Row 6:** Ch 1, dec 1 sc in first 2 sc, sc in each of next 5 sc, 2 sc in next sc, sc in each of next 8 sc, 2 sc in next sc, sc in each of next 5 sc, dec 1 sc in last 2 sc (24 sc), *turn*.

**Row 7:** Ch 1, dec 1 sc in first 2 sc, sc in each sc across to last 2 sc, dec 1 sc in last 2 sc (22 sc), *turn*.

**Row 8:** Ch 1, dec 1 sc in first 2 sc, sc in each of next 4 sc, 2 sc in next sc, sc in each of next 8 sc, 2 sc in next sc, sc in each of next 4 sc, dec 1 sc in last 2 sc (22 sc), *turn*.

**Row 9:** Ch 1, dec 1 sc in first 2 sc, sc in each sc across to last 2 sc, dec 1 sc in last 2 sc (20 sc). Fasten off.

### *Top*

**Row 1:** With right side facing, join yarn in rem loop of first st in Row 1 of visor bottom, ch 1, working in rem loops, sc in each of first 8 sc, (2 sc in next sc, sc in each of next 8 sc) twice (28 sc), *turn*.

**Rows 2–8:** Rep Rows 3–9 of visor bottom. Fasten off.

## *Finishing with basic stitches*

With right side facing, join yarn in center st at back of beret, sl st in each st around to first row of visor, working through double thickness of visor bottom and top, matching sts, sc in each sc around entire front edge of visor, sl st in each st around edge of beret, sl st in first sl st to join. Fasten off.

## *Variation: Add a different color*

Add a colorful twist to the hat by working the visor and edging in a complementary color.

## Red Velvet Crusher Hat

This hat will make you stand out in a crowd! The resulting fabric resembles crushed red velvet and is just as soft to the touch (see Figure 7-4). With hats featured so prominently these days, this pattern is a must. You use basic stitches and techniques and get ample opportunity to practice working in the round, but the results will make you look like an expert. If red isn't your color, go ahead and choose another color, but by all means, grab your hook and yarn and work up a fabulous fashion accessory.



**Figure 7-4:** You can toss this crusher hat in a bag when you're not wearing it, and it will retain its shape when you put it back on.

### Materials and vital statistics

- ✓ **Size:** One size fits most adults
- ✓ **Yarn:** Caron "Jewel Box" medium-weight yarn (64% acrylic/20% rayon/16% polyester), Article #JB1000 (2.5 oz. [70g], 100 yds [91 m] each skein): 2 skeins of #0020 Ruby
- ✓ **Hook:** Crochet hook size H-8 U.S. or size needed to obtain gauge
- ✓ **Stitch markers**
- ✓ **Measurement:** 22 in. in circumference
- ✓ **Gauge:** First 4 rnds = 2 in. in diameter
- ✓ **Stitches used:** Chain stitch (ch), slip stitch (sl st), single crochet (sc)

When making the transition from the crown of the hat to the sides, then again from the sides to the brim, you work your stitches into the back loops and front loops of the stitches, respectively. Remember, the back loops are the ones farthest from you, and the front loops are the ones closest to you.

## Directions

**Foundation chain:** Ch 4 and close into ring with sl st in first ch.

**Rnd 1:** Ch 1, work 6 sc in ring, do *not* join. Continue to work in a spiral, marking beginning of each rnd and moving marker up as work progresses.

**Rnd 2:** Work 2 sc in each sc around (12 sc).

**Rnd 3:** • Sc in next sc, 2 sc in next sc •, rep from • to • around (18 sc).

**Rnd 4:** • Sc in each of next 2 sc, 2 sc in next sc •, rep from • to • around (24 sc).

**Rnd 5:** • Sc in each of next 3 sc, 2 sc in next sc •, rep from • to • around (30 sc).

**Rnd 6:** • Sc in each of next 4 sc, 2 sc in next sc •, rep from • to • around (36 sc).

**Rnd 7:** • Sc in each of next 5 sc, 2 sc in next sc •, rep from • to • around (42 sc).

**Rnd 8:** • Sc in each of next 6 sc, 2 sc in next sc •, rep from • to • around (48 sc).

**Rnd 9:** • Sc in each of next 7 sc, 2 sc in next sc •, rep from • to • around (54 sc).

**Rnd 10:** • Sc in each of next 8 sc, 2 sc in next sc •, rep from • to • around (60 sc).

**Rnd 11:** • Sc in each of next 9 sc, 2 sc in next sc •, rep from • to • around (66 sc).

**Rnd 12:** Sc in each sc around (66 sc), sl st in first sc to join.

**Rnd 13:** Ch 1, working in back loops of sts, sc in each sc around (66 sc), do *not* join. Continue to work in a spiral as before.

**Rnds 14–25:** Sc in each sc around (66 sc).

**Rnd 26:** Working in front loops of sts, • sc in each of next 10 sc, 2 sc in next sc •, rep from • to • around (72 sc).

**Rnd 27:** Working in both loops of sts, • sc in each of next 11 sc, 2 sc in next sc •, rep from • to • around (78 sc).

**Rnd 28:** • Sc in each of next 12 sc, 2 sc in next sc •, rep from • to • around (84 sc).

**Rnd 29:** • Sc in each of next 13 sc, 2 sc in next sc •, rep from • to • around (90 sc).

**Rnd 30:** • Sc in each of next 14 sc, 2 sc in next sc •, rep from • to • around (96 sc).

**Rnd 31:** • Sc in each of next 15 sc, 2 sc in next sc •, rep from • to • around (102 sc).

**Rnd 32:** • Sc in each of next 16 sc, 2 sc in next sc •, rep from • to • around (108 sc).

**Rnd 33:** • Sc in each of next 17 sc, 2 sc in next sc •, rep from • to • around (114 sc).

**Rnd 34:** • Sc in each of next 18 sc, 2 sc in next sc •, rep from • to • around (120 sc), sl st in first sc to join. Fasten off.

## Bella Drawstring Bag

Fun and funky is the only way to describe this bag (see Figure 7-5). Most people need more than one carryall to cart around the various items that we can't seem to do without these days, and this pattern fits the purpose nicely. The yarn used is one of a hot new family — self-striping — which allows you to use different colors without having to actually change them. Beat that!



**Figure 7-5:** This drawstring bag with self-striping yarn looks much more complicated to make than it is.

### Materials and vital statistics

- ✓ **Yarn:** Plymouth Yarn “Bella Colour” worsted-weight yarn (55% cotton/45% acrylic), (1.75 oz. [50 g], 104 yds [95 m] each ball): 5 balls of #19 greens
- ✓ **Hook:** Crochet hook size I-9 U.S. or size needed to obtain gauge
- ✓ **Stitch markers**
- ✓ **Measurements:** 8½ in. in diameter x 10 in. tall
- ✓ **Gauge:** First 4 rnds = 4 in. in diameter
- ✓ **Stitches used:** Chain stitch (ch), slip stitch (sl st), single crochet (sc), double crochet (dc). **Shell:** • 4 dc in same st • **Picot:** • Ch 3, sl st in third ch from hook •

To make the bag's base, you use the more common technique of joining rounds when you get to the end of each one, and you work the sides in a spiral to avoid having an unseemly seam. Simple shells and picots make up the edging, and the cord is twisted rather than crocheted to give it a slightly different look.



## *Going 17 rounds for the base*

**Foundation chain:** Ch 2.

**Rnd 1:** Work 4 sc in 2nd ch from hook (4 sc), sl st in first sc to join.

**Rnd 2:** Ch 1, 2 sc in each sc around (8 sc), sl st in first sc to join.

**Rnd 3:** Ch 1, 2 sc in each sc around (16 sc), sl st in first sc to join.

**Rnd 4:** Ch 1, 2 sc in first sc, sc in next sc, • 2 sc in next sc, sc in next sc •, rep from • to • around (24 sc), sl st in first sc to join.

**Rnd 5:** Ch 1, 2 sc in first sc, sc in each of next 2 sc, • 2 sc in next sc, sc in each of next 2 sc •, rep from • to • around (32 sc), sl st in first sc to join.

**Rnd 6:** Ch 1, 2 sc in first sc, sc in each of next 3 sc, • 2 sc in next sc, sc in each of next 3 sc •, rep from • to • around (40 sc), sl st in first sc to join.

**Rnd 7:** Ch 1, 2 sc in first sc, sc in each of next 4 sc, • 2 sc in next sc, sc in each of next 4 sc •, rep from • to • around (48 sc), sl st in first sc to join.

**Rnd 8:** Ch 1, 2 sc in first sc, sc in each of next 5 sc, • 2 sc in next sc, sc in each of next 5 sc •, rep from • to • around (56 sc), sl st in first sc to join.

**Rnd 9:** Ch 1, 2 sc in first sc, sc in each of next 6 sc, • 2 sc in next sc, sc in each of next 6 sc •, rep from • to • around (64 sc), sl st in first sc to join.

**Rnd 10:** Ch 1, 2 sc in first sc, sc in each of next 7 sc, • 2 sc in next sc, sc in each of next 7 sc •, rep from • to • around (72 sc), sl st in first sc to join.

**Rnd 11:** Ch 1, 2 sc in first sc, sc in each of next 8 sc, • 2 sc in next sc, sc in each of next 8 sc •, rep from • to • around (80 sc), sl st in first sc to join.

**Rnd 12:** Ch 1, 2 sc in first sc, sc in each of next 9 sc, • 2 sc in next sc, sc in each of next 9 sc •, rep from • to • around (88 sc), sl st in first sc to join.

**Rnd 13:** Ch 1, 2 sc in first sc, sc in each of next 10 sc, • 2 sc in next sc, sc in each of next 10 sc •, rep from • to • around (96 sc), sl st in first sc to join.

**Rnd 14:** Ch 1, 2 sc in first sc, sc in each of next 11 sc, • 2 sc in next sc, sc in each of next 11 sc •, rep from • to • around (104 sc), sl st in first sc to join.

**Rnd 15:** Ch 1, 2 sc in first sc, sc in each of next 12 sc, • 2 sc in next sc, sc in each of next 12 sc •, rep from • to • around (112 sc), sl st in first sc to join.

**Rnd 16:** Ch 1, 2 sc in first sc, sc in each of next 13 sc, • 2 sc in next sc, sc in each of next 13 sc •, rep from • to • around (120 sc), sl st in first sc to join.

**Rnd 17:** Ch 1, sc in each sc around (120 sc), sl st in first sc to join, *turn*.

## *Working your way up the sides*

**Rnd 18:** Ch 1, working over sts in previous rnd, sc in each sc 2 rnds below (120 sc), sl st in first sc to join, *turn*.

**Rnd 19:** Ch 1, sc in each sc around (120 sc), do *not* join. Continue to work in a spiral, marking beg of each rnd, moving marker up as work progresses.

**Rnds 20–59:** Sc in each sc around (120 sc).

**Rnd 60:** Sc in each sc around (120 sc), sl st in first sc to join.

**Rnd 61 (beading rnd):** Ch 3 (first dc), ch 2, skip next 2 sc, • dc in next sc, ch 2, skip next 2 sc •, rep from • to • around (40 ch-2 spaces), sl st in top of turning ch to join.

**Rnd 62:** Ch 3 (first dc), dc in first dc, skip next ch-2 space, (sc, picot) in next dc, skip next ch-2 space, • shell in next dc, skip next ch-2 space, (sc, picot) in next dc, skip next ch-2 space •, rep from • to • around, 2 dc in same st as first 2 dc, sl st in top of turning ch to join. Fasten off.

## *Finishing with the drawstring cord*

To make the drawstring cord, cut yarn into three 4-yard lengths. With the lengths held together as one, fold the lengths in half. Tie cut ends in an overhand knot to secure.

Holding the knotted end in your hand, place the folded end over a hook such as the kind used to hold curtain tiebacks (or have a friend hold it for you), and pull taut. Twist the cord until you can't twist it any more and it begins to kink.

Carefully, keeping the twisted cord taut, place a finger in the center of the cord and fold it in half. Remove the folded end from the hook and allow the two ends of the cord to twist together. Pull gently on each end to even the twist, and tie each end in an overhand knot approximately 1 inch from the end to secure. Cut ends to form tassels.

To insert the cord into the bag, weave one end of cord under then over each of the double crochet stitches in Round 61, leaving equal lengths on both sides.

## *Variation: Making a sturdier bag*

To add support to the bottom of the bag, cut a circle from a piece of thick plastic to fit inside.

If you'd like to take this bag to the beach, make the bag using a worsted-weight nylon yarn, which will stand up to the abuse of sun and sand.

# Chapter 8

## Coloring It In

---

### *In This Chapter*

- ▶ Changing color and texture to crochet a fashion-forward scarf
  - ▶ Using various colors and stitches to create a comfortable cloche
  - ▶ Designing with shells and clusters in a wavy throw
  - ▶ Crocheting with chenille to make a feet-pleasing throw rug
- 

Changing colors is an integral part of crochet, and being able to change colors properly is absolutely essential. The technique is not difficult, but if you do it incorrectly, you can ruin the final look of your design.



Here are a couple things to remember before you get started:

- ✓ When joining a new yarn color, always finish the last stitch of the first color with the second color, regardless of the type of stitch you're working (see Chapter 4 for detailed info on changing colors). Doing so gets you ready to start the first stitch of the second color with the correct color loop on your hook. This also prevents *color drag*, which is what happens when part of a stitch is one color and the rest of a stitch is another color. Starting the new color in the last stitch of the old color applies to all color changes, regardless of whether you change yarn at the end of a row or round, or midstream.
- ✓ Hide the tail end of the yarn color by laying it across the tops of the stitches in the previous row and working over it, or weaving it in with a yarn needle when you finish crocheting.

The patterns in this chapter give you the opportunity to practice changing colors. The color changes all take place at the beginning (or end) of a row or round, but the concept is the same no matter where the change takes place.

## *A Scarf of a Different Color*

Crocheting this scarf is really fun, and it'll certainly brighten up your wardrobe. Not only are you changing colors with each row, but textures as well (see Figure 8-1). You work the scarf completely with single crochet stitches, but you'd never know to look at it. Sometimes it's okay to mix and match yarns, and this design is a great example.



**Figure 8-1:**  
By using the single crochet stitch in this scarf, you can focus on changing colors.

## *Materials and vital statistics*

### ✓ **Yarn:**

- Bernat “Matrix” railroad yarn (62% nylon/38% polyester), Article #166102 (1.75 oz. [50 g], 140 yds [128 m] each ball): 1 ball of #02430 Web Wines (A)
- Patons “Silverlash” eyelash yarn (98% polyester/2% lurex), Article #244081 (1.75 oz. [50 g], 164 yds [150 m] each skein): 1 skein of #81415 Rose Quartz (B)
- Patons “Lacette” fine-weight yarn (39% nylon/36% acrylic/25% mohair), Article #243030 (1.75 oz. [50 g], 235 yds [215 m] each skein): 1 skein of #30040 Touch of Black (C)
- Patons “Silverlash” eyelash yarn (98% polyester/2% lurex), Article #244081 (1.75 oz. [50 g], 164 yds [150 m] each skein): 1 skein of #81405 Maroon Magic (D)
- Patons “Lacette” fine-weight yarn (39% nylon/36% acrylic/25% mohair), Article #243030 (1.75 oz. [50 g], 235 yds [215 m] each skein): 1 skein of #30008 Cream Caress (E)

You’ll have enough yarn to make several scarves.

✓ **Hook:** Crochet hook size H-8 U.S. or size needed to obtain gauge

✓ **Measurements:** ¾ in. wide x 45 in. long

✓ **Gauge:** 8 sts = 2 in.; 6 rows = 1 in.

✓ **Stitches used:** Chain stitch (ch), slip stitch (sl st), single crochet (sc)

The beauty of this design reveals itself as you complete each row. You’ll get lots of practice changing yarn colors, and the great thing is the textures will hide any slip-ups if you don’t get it quite right the first time. Because the scarf is worked in single crochet stitches, it’s also a great project to help you get used to working with novelty yarns.

## Directions

**Foundation chain:** With A, ch 201.

**Row 1 (right side):** Sc in 2nd ch from hook, sc in each ch across (200 sc), *turn*. Fasten off A, join B.

**Row 2:** With B, ch 1, sc in each sc across (200 sc), *turn*. Fasten off B, join C.

**Row 3:** With C, ch 1, sc in each sc across (200 sc), *turn*. Fasten off C, join B.

**Row 4:** With B, ch 1, sc in each sc across (200 sc), *turn*. Fasten off B, join A.

**Row 5:** With A, ch 1, sc in each sc across (200 sc), *turn*. Fasten off A, join D.

**Row 6:** With D, ch 1, sc in each sc across (200 sc), *turn*. Fasten off D, join E.

**Row 7:** With E, ch 1, sc in each sc across (200 sc), *turn*. Fasten off E, join D.

**Row 8:** With D, ch 1, sc in each sc across (200 sc), *turn*. Fasten off D, join A.

**Row 9:** With A, ch 1, sc in each sc across (200 sc), *turn*. Fasten off A, join C.

**Row 10:** With C, ch 1, sc in each sc across (200 sc), *turn*. Fasten off C, join A.

**Row 11:** With A, ch 1, sc in each sc across (200 sc), *turn*. Fasten off A, join D.

**Row 12:** With D, ch 1, sc in each sc across (200 sc), *turn*. Fasten off D, join E.

**Row 13:** With E, ch 1, sc in each sc across (200 sc), *turn*. Fasten off E, join D.

**Row 14:** With D, ch 1, sc in each sc across (200 sc), *turn*. Fasten off D, join A.

**Row 15:** With A, ch 1, sc in each sc across (200 sc), *turn*. Fasten off A, join B.

**Row 16:** With B, ch 1, sc in each sc across (200 sc), *turn*. Fasten off B, join C.

**Row 17:** With C, ch 1, sc in each sc across (200 sc), *turn*. Fasten off C, join B.

**Row 18:** With B, ch 1, sc in each sc across (200 sc), *turn*. Fasten off B, join A.

**Row 19:** With A, ch 1, sc in each sc across (200 sc), *turn*.

**Row 20:** Ch 1, sc in each sc across (200 sc). Fasten off.

## Denim Cloche

You've probably seen these little hats everywhere, and now you can make your own in no time at all (see Figure 8-2). Denim never goes out of style, and the yarn used here is probably as close to the real thing as I've ever seen. My guess is you'll have to fight your teens off to get to wear this hat.



**Figure 8-2:**  
A snug-fitting cloche won't blow off on a windy winter day.



You change colors when working in the round the same way as when you work in rows: Complete the last stitch of the old color with the new color. You get a seamless transition with no color drag.

## Materials and vital statistics

- ✓ **Size:** One size fits most adults
- ✓ **Yarn:** Twilleys of Stamford “Denim Freedom” sport-weight yarn (100% cotton), (1.75 oz. [50 g], 102 yds [93 m] each ball): 1 ball each of
  - #104 Navy (A)
  - #101 Natural (B)
  - #102 Blue (C)
- ✓ **Hook:** Crochet hook size G-6 U.S. or size needed to obtain gauge
- ✓ **Measurement:** 21 in. in circumference
- ✓ **Gauge:** First 4 rnds = 2½ in.
- ✓ **Stitches used:** Chain stitch (ch), slip stitch (sl st), single crochet (sc), double crochet (dc)



The inherent characteristics of this yarn make it fade and shrink a bit, so be sure to wash the cloche before you wear it the first time. After a while, it'll look like your favorite pair of jeans.

You create the pattern in the hat by varying the stitches in different rounds, from double crochet stitches to single crochet stitches, and even creating spaces to work in with a chain stitch thrown in.

## Directions

**Foundation chain:** With A, ch 4 and close into a ring with 1 sl st in first ch.

**Rnd 1:** Ch 3 (first dc), work 5 dc in ring (6 dc), sl st in first dc to join.

**Rnd 2:** Ch 3 (first dc), dc in first dc, 2 dc in each dc around (12 dc), sl st in first dc to join.

**Rnd 3:** Ch 3 (first dc), dc in first dc, dc in next dc, • 2 dc in next dc, dc in next dc •, rep from • to • around (18 dc), sl st in first dc to join.

**Rnd 4:** Ch 3 (first dc), dc in first dc, dc in each of next 2 dc, • 2 dc in next dc, dc in each of next 2 dc •, rep from • to • around (24 dc), sl st in first dc to join.

**Rnd 5:** Ch 3 (first dc), dc in first dc, dc in each of next 3 dc, • 2 dc in next dc, dc in each of next 3 dc •, rep from • to • around (30 dc), sl st in first dc to join.

**Rnd 6:** Ch 3 (first dc), dc in first dc, dc in each of next 4 dc, • 2 dc in next dc, dc in each of next 4 dc •, rep from • to • around (36 dc), sl st in first dc to join. Fasten off A, join B.

**Rnd 7:** With B, ch 1, 2 sc in first dc, sc in each of next 5 dc, • 2 sc in next dc, sc in each of next 5 dc •, rep from • to • around (42 sc), sl st in first sc to join.

**Rnd 8:** Ch 1, 2 sc in first sc, sc in each of next 6 sc, • 2 sc in next sc, sc in each of next 6 sc •, rep from • to • around (48 sc), sl st in first sc to join. Fasten off B, join C.

**Rnd 9:** With C, ch 3 (first dc), dc in first sc, dc in each of next 7 sc, • 2 dc in next sc, dc in each of next 7 sc •, rep from • to • around (54 dc), sl st in first dc to join.

**Rnd 10:** Ch 3 (first dc), dc in first dc, dc in each of next 8 dc, • 2 dc in next dc, dc in each of next 8 dc •, rep from • to • around (60 dc), sl st in first dc to join. Fasten off C, join B.

**Rnd 11:** With B, ch 1, 2 sc in first dc, sc in each of next 9 dc, • 2 sc in next dc, sc in each of next 9 dc •, rep from • to • around (66 sc), sl st in first sc to join. Fasten off B, join A.

**Rnd 12:** With A, ch 3 (first dc), dc in first sc, dc in each of next 10 sc, • 2 dc in next sc, dc in each of next 10 sc •, rep from • to • around (72 dc), sl st in first dc to join.

**Rnd 13:** Ch 3 (first dc), dc in first dc, dc in each of next 11 dc, • 2 dc in next dc, dc in each of next 11 dc •, rep from • to • around (78 dc), sl st in first dc to join.

**Rnd 14:** Ch 3 (first dc), dc in first dc, dc in each of next 12 dc, • 2 dc in next dc, dc in each of next 12 dc •, rep from • to • around (84 dc), sl st in first dc to join. Fasten off A, join B.

**Rnd 15:** With B, ch 1, sc in first dc, ch 1, skip next dc, • sc in next dc, ch 1, skip next dc •, rep from • to • around (84 sts), sl st in first sc to join. Fasten off B, join C.

**Rnd 16:** With C, ch 2, skip first sc, • sc in next ch-1 space, ch 1, skip next sc •, rep from • to • around (84 sts), sl st in first ch to join. Fasten off C, join B.

**Rnd 17:** With B, ch 1, sc in first ch-1 space, ch 1, skip next sc, • sc in next ch-1 space, ch 1, skip next sc •, rep from • to • around (84 sts), sl st in first sc to join. Fasten off B, join A.

**Rnd 18:** With A, ch 3 (first dc), dc in each sc and each ch-1 space around (84 dc), sl st in first dc to join.

**Rnd 19:** Ch 3 (first dc), dc in each dc around (84 dc), sl st in first dc to join. Fasten off A, join B.

**Rnd 20:** With B, ch 1, sc in each dc around (84 sc), sl st in first sc to join. Fasten off B, join C.

**Rnd 21:** With C, ch 1, sc in each sc around (84 sc), sl st in first sc to join. Fasten off C, join A.

**Rnd 22:** With A, ch 1, sc in each sc around (84 sc), sl st in first sc to join. Fasten off.

## Wavy Chevron Throw

Sometimes, there's nothing like having a soft, warm blanket to throw over your legs or wrap around your shoulders to keep the chill out (see Figure 8-3). The *chevron* pattern (a fancy way to describe the repeated V shape) features shells at the peaks and clusters at the valleys.

This pattern probably falls into the intermediate skill-level category because of the stitch combination involved in creating the pattern. The pattern is commonly used, and it's a great way for you to become familiar with a design that you'll see repeatedly throughout your crochet experience.

The yarn used here is a wonderfully soft acrylic, which stands up to daily use and repeated washings. You should be able to find the yarn in most craft stores, and it comes in a multitude of colors if you decide on a different color palette.



**Figure 8-3:** Complementary colors draw attention to the chevron design of this afghan.



## Materials and vital statistics

- ✓ **Yarn:** Lion Brand Yarn “Homespun” bulky-weight yarn, (98% acrylic/2% polyester), Article #790 (6 oz. [170 g], 185 yds [169 m] each skein):
  - 5 skeins of #347 Mediterranean (A)
  - 3 skeins of #318 Sierra (B)
  - 3 skeins of #326 Ranch (C)
- ✓ **Hook:** Crochet hook size K-10½ U.S. or size needed to obtain gauge
- ✓ **Measurements:** 36 in. wide x 58 in. long, excluding tassels
- ✓ **Gauge:** 11 sts in pat = 4 in.; 6 rows in pat = 4 in.
- ✓ **Stitches used:** Chain stitch (ch), double crochet (dc). **Shell:** • 3 dc in same stitch •. **Cluster:** • 3 dc (half closed and joined tog) worked across 3 consecutive stitches •. (See Appendix A for detailed instructions on shells and clusters.)

The stitch pattern used to make this throw is a simple chevron pattern, comprised of shell stitches and clusters. The shells are made with three double crochet stitches worked into one stitch, and the clusters are three double crochet stitches, half-closed and joined together, worked across three separate stitches (see Figure 8-4). The shells form the peaks, while the clusters draw the fabric together to form the valleys of the pattern.

**Figure 8-4:**  
Reduced  
sample of  
stitch  
pattern.

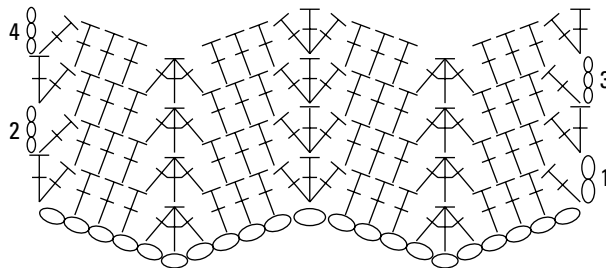

## Directions

**Foundation chain:** With A, chain 101 + 2 (first dc).



Normally, the first dc in a row is made by working 3 chain stitches, not 2. However, for the foundation row in this pattern, a chain of only 2 stitches is used. The rest of the pattern uses a turning ch of 3 for the first dc in a row.

**Row 1 (right side):** Dc in 3rd ch from hook, • dc in each of next 3 ch, work one cluster of 3 dc across next 3 ch, dc in each of next 3 ch, shell in next ch •, rep from • to • across to within last ch, 2 dc in last ch (102 sts), *turn*.

**Row 2:** Ch 3 (first dc), dc in first dc, • dc in each of next 3 dc, work one cluster of 3 dc across next 3 sts (the center dc of the cluster will be worked in the top of the cluster in the row below), dc in each of next 3 dc, shell in next dc (the shell will be worked in the center dc of the shell from the row below) •, rep from • to • across to within last dc, 2 dc in last dc (102 sts), *turn*.

**Rows 3–7:** Rep Row 2. Fasten off A, join B.

**Rows 8–10:** With B, rep Row 2. Fasten off B, join C.

**Rows 11–12:** With C, rep Row 2. Fasten off C, join B.

**Row 13:** With B, rep Row 2. Fasten off B, join A.

**Rows 14–21:** With A, rep Row 2. Fasten off A, join C.

**Row 22:** With C, rep Row 2. Fasten off C, join B.

**Row 23:** With B, rep Row 2. Fasten off B, join C.

**Row 24:** With C, rep Row 2. Fasten off C, join A.

**Rows 25–32:** With A, rep Row 2. Fasten off A, join B.

**Row 33:** With B, rep Row 2. Fasten off B, join C.

**Rows 34–35:** With C, rep Row 2. Fasten off C, join B.

**Rows 36–38:** With B, rep Row 2. Fasten off B, join A.

**Rows 39–46:** With A, rep Row 2. Fasten off A, join B.

**Rows 47–78:** Rep Rows 8–38. Fasten off B, join A.

**Rows 79–85:** With A, rep Row 2. Fasten off.

**Adding tassels:** To make a tassel, cut two 8-inch lengths of colors A, B, and C. Holding all lengths together as one, fold in half. Cut two more 6-inch lengths of color A. Using one 6-inch length of yarn, tie the bundle securely together through the center fold, leaving equal lengths on each side. With the bundle folded in half, wrap the second length of yarn several times around the folded bundle approximately  $\frac{3}{4}$  in. below folded end. Tie tightly to secure. Make 20 tassels.

To attach the tassels, use the ends of yarn from the first tie at the center top of the tassel to tie one tassel to each point across each short edge of throw.

### ***Variation: Highlight the stitches, not the colors***

This stitch pattern also looks great worked in a solid color. The yarn used comes in a multitude of shades, so choose your own solid or color combination.

## ***Cozy Chenille Throw Rug***

Your feet will absolutely love you every time they encounter this chenille throw rug. Place it next to your bed or at the foot of your favorite chair and sink your feet into its cozy warmth. The chenille yarn used is super bulky in weight, making this a quick project to work up, and it also gives the rug depth (see Figure 8-5). Use the colors given, or choose a palate that matches your décor.



**Figure 8-5:**  
You'll want  
to burrow  
your toes  
into this  
chenille  
throw rug.

## Materials and vital statistics

- ✓ **Yarn:** Lion Brand Yarn “Chenille Thick & Quick” super-bulky-weight yarn (91% acrylic/9% rayon), Article #950 (100 yds [90 m] each skein):
  - 3 skeins of #178 Basil (A)
  - 1 skein of #155 Champagne (B)
  - 1 skein of #136 Terracotta (C)
  - 1 skein of #126 Chocolate (D)
- ✓ **Hook:** Crochet hook size P-15 U.S. or size needed to obtain gauge
- ✓ **Measurements:** 40 in. wide x 29 in. long
- ✓ **Gauge:** 6 sts and 6 rows in pat = 4 in.
- ✓ **Stitches used:** Chain stitch (ch), slip stitch (sl st), single crochet (sc), long single crochet (lsc), half double crochet (hdc)

The pattern for this rug is primarily made up of half double crochet stitches, with some simple variations thrown in for interest. Half double crochet stitches are nice and fat, especially when worked with a bulky yarn. The edging gets a feminine, ruffled look by working chain stitches between the single crochet stitches.

## Directions

**Foundation chain:** With A, ch 60 + 2 (first hdc).

**Row 1 (right side):** Hdc in 3rd ch from hook, hdc in each ch across (61 hdc), *turn*.

**Rows 2–3:** Ch 2 (first hdc), hdc in each hdc across (61 hdc), *turn*. Fasten off A, join D.

**Row 4:** With D, ch 1, sc in first hdc, • ch 1, skip next hdc, sc in next hdc •, rep from • to • across (31 sc and 30 ch-1 spaces), *turn*. Fasten off D, join B.

**Row 5:** With B, ch 1, sc in first sc, • working over ch-1 in previous row, lsc in hdc 2 rows below, sc in next sc in current row •, rep from • to • across (31 sc and 30 lsc), *turn*. Fasten off B, join C.

**Rows 6–7:** With C, ch 2 (first hdc), hdc in each hdc across (61 hdc), *turn*. Fasten off C, join B.

**Row 8:** With B, ch 1, sc in each hdc across (61 sc), *turn*. Fasten off B, join D.

**Row 9:** With D, ch 1, sc in each sc across (61 sc), *turn*. Fasten off D, join B.

**Row 10:** With B, ch 1, sc in each sc across (61 sc), *turn*. Fasten off B, join A.

**Rows 11–13:** With A, ch 2 (first hdc), hdc in each st across (61 hdc), *turn*. Fasten off A, join B.

**Rows 14–16:** Rep Rows 8–10.

**Rows 17–22:** With A, ch 2 (first hdc), hdc in each hdc across, *turn*. Fasten off A, join D.

**Row 23:** With D, ch 1, sc in each hdc across (61 sc), *turn*. Fasten off D, join C.

**Row 24:** With C, ch 1, sc in each sc across (61 sc), *turn*. Fasten off C, join B.

**Row 25:** With B, ch 1, sc in each sc across (61 sc), *turn*. Fasten off B, join C.

**Row 26:** With C, ch 1, sc in each sc across (61 sc), *turn*. Fasten off C, join D.

**Row 27:** With D, ch 1, sc in each sc across (61 sc), *turn*. Fasten off D, join A.

**Rows 28–33:** With A, ch 2 (first hdc), hdc in each sc across (61 hdc), *turn*. Fasten off A, join B.

**Row 34:** With B, ch 1, sc in each hdc across (61 sc), *turn*. Fasten off B, join D.

**Row 35:** With D, ch 1, sc in each sc across (61 sc), *turn*. Fasten off D, join B.

**Row 36:** With B, ch 1, sc in each sc across (61 sc), *turn*. Fasten off B, join A.

**Rows 37–39:** With A, ch 2 (first hdc), hdc in each sc across (61 hdc), *turn*. Fasten off A, join B.

**Rows 40–41:** Rep Rows 34–35. Fasten off D, join B.

**Row 42:** With B, ch 1, sc in each sc across (61 sc), *turn*. Fasten off B, join C.

**Rows 43–44:** With C, ch 2 (first hdc), hdc in each st across (61 hdc), *turn*. Fasten off C, join B.

**Row 45:** With B, ch 1, sc in first sc, • ch 1, skip next hdc, sc in next hdc •, rep from • to • across (31 sc and 30 ch-1 spaces), *turn*. Fasten off B, join D.

**Row 46:** With D, ch 1, sc in first sc, • working over ch-1 in previous row, lsc in hdc 2 rows below, sc in next sc in current row •, rep from • to • across (31 sc and 30 lsc), *turn*. Fasten off D, join A.

**Rows 47–49:** With A, ch 2 (first hdc), hdc in each st across (61 hdc), *turn*. *Do not turn at end of last row.*

**Edging:** Working in row-end sts across short edge of rug, sc in corner st, ••• ch 2, sc in next st •, rep from • to • across to next corner, (sc, ch 2, sc) in corner st ••, rep from •• to •• around, sl st in first sc to join. Fasten off.

### ***Variation: Size it to fit just right***

If you need a larger or smaller rug to fit your particular space, you can always change the number of chain stitches in your foundation chain. When working your foundation chain, make sure you have an odd number of stitches to accommodate the stitch pattern.

To figure out how many more (or fewer) stitches you need to adjust the size, use the gauge given in the beginning of the instructions (6 sts and 6 rows = 4 in.). Decide in inches what you want the finished dimensions to be, then divide by 4 (gauge) and multiply by 6 (sts). See Chapter 2 for detailed info on gauge.

### ***Variation: Fringe it!***

Omit the edging and add fringe to the short edges of the rug in colors to match the stripes for a whole new look (see Appendix A for fringe how-to's).



## Chapter 9

# Mixing It Up: A Few Changes Make a Dramatic Difference

### *In This Chapter*

- ▶ Crocheting a hip belt
- ▶ Increasing in size to create a fashion-forward scarf
- ▶ Working in the round to make the ever-popular rolled-brim hat for kids
- ▶ Moving up a size to crochet a rolled-brim hat for adults

The projects in this chapter illustrate the importance of gauge and of using the proper materials listed with each pattern. The size of the hook you use dictates the size of the stitches made, which in turn creates the stitch *gauge*, or number of stitches and rows per a given measurement. Using a different weight yarn while keeping the hook size the same also alters the outcome of your gauge and the appearance of your fabric. For instance, if you use a lighter-weight yarn than the pattern calls for, but keep your hook size the same, the resulting fabric will have looser stitches and a more open look.

For a pattern to work consistently time after time, you have to use the same size materials, both hook and yarn, each time. By changing the hook size and/or the yarn weight, your project can turn out dramatically different (see Chapter 2 for detailed information on gauge and Chapter 1 for materials).

The following list explains how using different materials affects the gauge:

- ✔ **Larger hook with the same size yarn:** Fewer stitches per given measurement with the resulting project turning out larger than intended.
- ✔ **Smaller hook with the same size yarn:** More stitches per given measurement with resulting project turning out smaller than intended.
- ✔ **Same size hook with heavier-weight yarn:** Fewer stitches per given measurement with the resulting project turning out larger than intended with a tighter fabric.
- ✔ **Same size hook with a lighter-weight yarn:** More stitches per given measurement with the resulting project turning out smaller than intended with a looser fabric.
- ✔ **Larger hook with heavier-weight yarn:** The finished design will increase in size proportionally from the original size, provided that the hook size is the one recommended for use with the yarn.
- ✔ **Smaller hook with lighter-weight yarn:** The finished design will decrease in size proportionally from the original size, provided that the hook size is the one recommended for use with the yarn.



This isn't to say that you can't substitute yarn — but if you want your project to turn out the same as the pattern dimensions, the yarn has to be the same weight as the recommended yarn in the materials list.

In the first pattern, you create a fanciful belt with a pattern that creates a series of bows and ruffles running across its length. That belt turns into a feminine scarf in the second pattern, simply by using a heavier weight of yarn and a larger hook.

In the third pattern, you make a child's rolled-brim hat using a yarn that has the look of many seed beads strung together. Using the identical pattern, you can create a softer (and larger) version for an adult, simply by using different yarn and a larger hook.

Not all patterns can be adapted this way, but the ones in this chapter give you a sense of how important it is to follow the directions given with an individual pattern, and how even the smallest change can affect the final outcome.

## Beads-'n'-Bows Belt

This design is an ultra-feminine belt with frills, beads, and bows (see Figure 9-1). Don't worry about finding beads — this new yarn incorporates the beads right into the strands, which eliminates the necessity of stringing the beads before getting started. Because this project introduces a new stitch pattern, it's suitable for someone with intermediate-level skills. To help you out, the instructions walk you through each step, and you'll find that you can work the new stitches with relative ease and add a new skill to your repertoire.

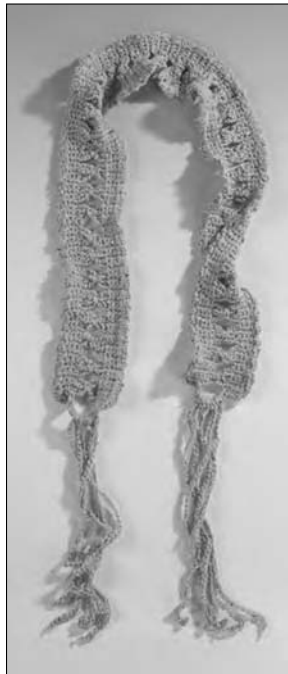

**Figure 9-1:** The beads-'n'-bows belt adds a feminine touch to a spring skirt.

### Materials and vital statistics

- ✓ **Size:** Directions given are for size Small (28 in.). Changes for Medium (32 in.), Large (36 in.), and X-Large (40 in.) are in parentheses.
- ✓ **Yarn:** Moda Dea “Beadnik” worsted-weight yarn (90% acrylic/5% polyester/5% PVC), Article #R149 (1.76 oz. [50 g], 103 yds [95 m] each ball): 2 balls of #2923 Daddy-O Tan



- ✓ **Hook:** Crochet hook size H-8 U.S. or size needed to obtain gauge
- ✓ **Measurements:** 3 in. wide x 28 (32, 36, 40) in. long, excluding ties
- ✓ **Gauge:** 13 sts in pat = 2½ in.; 8 rows in pat = 2 in.
- ✓ **Stitches used:** Chain stitch (ch), single crochet (sc). **Long single crochet (lsc):** • Working over 3 ch-8 loops formed in previous 3 rows, work 1 sc, thus gathering loops together •. (See Appendix A for exact details on how to work this stitch.)  
**Shell:** • 5 sc in same st •.

The bows in this design are crocheted using a series of single crochet stitches and chain loops, which are then drawn together in the center with a long single crochet stitch. The edging is comprised of a variation of the shell stitch using single crochet stitches rather than the more traditional double crochet shell.

And don't worry about the beads in this yarn getting hung up — they're small seed beads and slide right through the loops that create the stitches.

## Directions



If none of the sizes listed in the “Materials and vital statistics” section quite fit your particular shape, work the pattern repeat to ½ in. less than the desired length, then work the last two rows.

**Foundation chain:** Ch 14.

**Row 1 (right side):** Sc in 2nd ch from hook, sc in each ch across (13 sc), *turn*. (Figure 9-2 shows the stitch diagram for the first five rows.)

**Row 2:** Ch 1, sc in each of first 3 sc, ch 8, skip next 7 sc, sc in each of last 3 sc (14 sts), *turn*.

**Rows 3–4:** Ch 1, sc in each of first 3 sc, ch 8, skip next ch-8 loop, sc in each of last 3 sc (14 sts), *turn*.

**Row 5:** Ch 1, sc in each of first 3 sc, ch 3, lsc over 3 ch-8 loops, ch 3, sc in each of last 3 sc (13 sts), *turn*.

Rep Rows 2–5 until belt measures 27½ (31½, 35½, 39½) in.

**Next Row:** Ch 1, sc in each of first 3 sc, ch 8, sc in each of last 3 sc (14 sts), *turn*.

**Next Row:** Ch 1, sc in each of first 3 sc, work 7 sc in ch-8 loop, sc in each of last 3 sc (13 sc), *do not turn*.

**Figure 9-2:** Stitch diagram for the beads-'n'-bows belt and the ruffles-'n'-bows scarf.

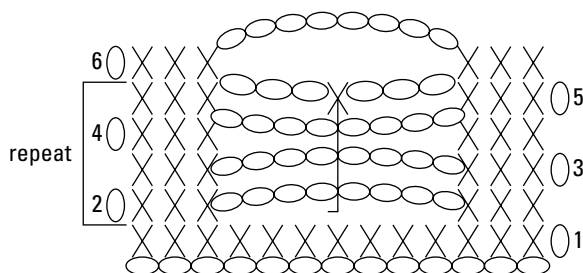

**Edging:** Working in row-end sts across long edge of belt, sc in first row-end st, • shell in next st, skip next st •, rep from • to • across to within last st, sc in last st. Fasten off.

With right side facing, rep edging across long edge on other side of belt.

**Ties:** With right side facing, • join yarn in ch-8 loop on one short end formed by first 2 rows, ch 50. Fasten off •. Rep from • to • 4 times in ch-8 loop. For the other tie, rep from • to • 5 times in ch-8 loop on other short end.

## Ruffles-'n'-Bows Scarf

The basic pattern for this scarf is exactly the same as the one for the beads-'n'-bows belt, with the exception of the ties (you really don't need them for a scarf). You work the stitches the same, but the outcome is quite different. When you change the weight of the yarn and size of the hook, you create a different material (see Figure 9-3). Instead of ruffles and bows around your waist, you can now wear them around your neck.

This project is for someone who has mastered the basic crochet stitches and is ready to move on to new stitches. Make sure to work your gauge swatch to get the hang of the long single crochet stitch, and you'll be moving through each step just like a pro.



**Figure 9-3:** A scarf with ruffles and bows creates a soft frame for your face.

### Materials and vital statistics

- ✓ **Yarn:** Coats and Clark Red Heart “Casual Cot’n” bulky-weight yarn (61% acrylic/29% cotton/10% polyester), Article #E723 (4 oz. [113 g], 140 yds [128 m] each skein): 2 skeins of #3937 Grand Canyon
- ✓ **Hook:** Crochet hook size J-10 U.S. or size needed to obtain gauge
- ✓ **Measurements:** 4 in. wide x 60 in. long
- ✓ **Gauge:** 13 sts in pat = 3¼ in.; 8 rows in pat = 2¼ in.

✓ **Stitches used:** Chain stitch (ch), single crochet (sc). **Long single crochet (lsc):** • Working over 3 ch-8 loops formed in previous 3 rows, work 1 sc, thus gathering loops together •. (See Appendix A for exact details on how to work this stitch.)  
**Shell:** • 5 sc in same st •.

This pattern really uses only two different stitches, the chain stitch and the single crochet stitch. The other two listed in the “Stitches used” line are just variations and combinations of the single crochet. Work your chains and gather them together to form the bow-like design, then add some single crochet shells across the edges, and you’ve got a feminine scarf to dress up your outerwear.

## Directions

Refer to Figure 9-2 in the “Directions” section for the beads-’n’-bows belt for the stitch diagram for this pattern (remember, the pattern for the belt and scarf are the same).

**Foundation chain:** Ch 14.

**Row 1 (right side):** Sc in 2nd ch from hook, sc in each ch across (13 sc), *turn*.

**Row 2:** Ch 1, sc in each of first 3 sc, ch 8, skip next 7 sc, sc in each of last 3 sc (14 sts), *turn*.

**Rows 3–4:** Ch 1, sc in each of first 3 sc, ch 8, skip next ch-8 loop, sc in each of last 3 sc (14 sts), *turn*.

**Row 5:** Ch 1, sc in each of first 3 sc, ch 3, lsc over 3 ch-8 loops, ch 3, sc in each of last 3 sc (13 sts), *turn*.

Rep Rows 2–5 until scarf measures 59 in. in length.

**Next Row:** Ch 1, sc in each of first 3 sc, ch 8, sc in each of last 3 sc (14 sts), *turn*.

**Next Row:** Ch 1, sc in each of first 3 sc, work 7 sc in ch-8 loop, sc in each of last 3 sc (13 sc), *do not turn*.

**Edging:** Working in row-end sts across long edge of scarf, sc in first row-end st, • shell in next st, skip next st •, rep from • to • across to within last st, sc in last st. Fasten off.

With right side facing, rep edging across long edge on other side of scarf.

## Child’s Rolled-Brim Hat

In most parts of the country, hats are an indispensable part of a child’s cool-weather wardrobe. The best kind of hat is one that your child can just pull on with no fuss and then pull off again and throw in the closet (or shove into a backpack). This design is for a basic hat with a rolled brim, and the yarn has the look of many tiny beads strung together, which gives it a really fun pattern, as shown in Figure 9-4.



**Figure 9-4:**  
The yarn creates a unique pattern in the child's rolled-brim hat.

## Materials and vital statistics

- ✓ **Size:** One size fits most children
- ✓ **Yarn:** Aunt Lydia's "Beadies Crochet" worsted-weight yarn (94% acrylic/6% polyester), Article #159 (1.765 oz. [50 g], 66 yds [60 m] each skein); 2 skeins of #00356 Flower Power
- ✓ **Hook:** Crochet hook size I-9 U.S. or size needed to obtain gauge
- ✓ **Yarn needle**
- ✓ **Measurement:** 20 in. in circumference
- ✓ **Gauge:** First 3 rnds = 2¾ in.
- ✓ **Stitches used:** Chain stitch (ch), slip stitch (sl st), double crochet (dc)

Starting at the top of the hat, working in rounds, you increase the diameter using double crochet stitches until the correct size is reached, and then you work the pattern evenly for several rounds until the desired depth is met. You create the brim by rolling the last two rounds up toward the outside, and then sewing the last round to the hat itself. For a refresher on working in rounds, see Chapter 4.

## Directions

**Center ring:** Ch 4 and close into a ring with 1 sl st in first ch.

**Rnd 1:** Ch 3 (first dc), work 7 dc in ring (8 dc), sl st in first dc to join.

**Rnd 2:** Ch 3 (first dc), dc in first dc, 2 dc in each dc around (16 dc), sl st in first dc to join.

**Rnd 3:** Ch 3 (first dc), dc in first dc, dc in next dc, • 2 dc in next dc, dc in next dc •, rep from • to • around (24 dc), sl st in first dc to join.

**Rnd 4:** Ch 3 (first dc), dc in first dc, dc in each of next 2 dc, • 2 dc in next dc, dc in each of next 2 dc •, rep from • to • around (32 dc), sl st in first dc to join.

**Rnd 5:** Ch 3 (first dc), dc in first dc, dc in each of next 3 dc, • 2 dc in next dc, dc in each of next 3 dc •, rep from • to • around (40 dc), sl st in first dc to join.

**Rnd 6:** Ch 3 (first dc), dc in first dc, dc in each of next 4 dc, • 2 dc in next dc, dc in each of next 4 dc •, rep from • to • around (48 dc), sl st in first dc to join.

**Rnd 7:** Ch 3 (first dc), dc in first dc, dc in each of next 5 dc, • 2 dc in next dc, dc in each of next 5 dc •, rep from • to • around (56 dc), sl st in first dc to join.

**Rnd 8:** Ch 3 (first dc), dc in first dc, dc in each of next 6 dc, • 2 dc in next dc, dc in each of next 6 dc •, rep from • to • around (64 dc), sl st in first dc to join.

**Rnds 9–16:** Ch 3 (first dc), dc in each dc around (64 dc), sl st in first dc to join.

**Rnd 17:** Ch 3 (first dc), dc in each dc around (64 dc), sl st in first dc to join. Fasten off.

**Brim:** With right side facing, roll last two rounds of hat up toward the outside, creating a rolled edge around the entire lower edge of hat. Using yarn needle and approximately 24 in. of yarn, sew last round of stitches to third round from bottom edge.

## *Adult's Rolled-Brim Hat*

Just like kids, adults need to keep their heads warm, too, and this pattern, which is identical to the child's rolled-brim hat pattern (see the previous project), adapts well to the increase in size. Simply by changing the materials, you can create a hat that not only functions well, but looks good, too. The resulting fabric is a bit more open and airy (see Figure 9-5), providing a finished design that will keep you warm and looking good.

As you create this project, you'll see that by using different materials, you can change the final outcome without a complete redesign.



**Figure 9-5:**  
The adult version of the rolled-brim hat is simple and functional.

## *Materials and vital statistics*

- ✓ **Size:** One size fits most adults
- ✓ **Yarn:** Aunt Lydia's "New Wave Crochet" worsted-weight yarn (96% polyester/4% nylon), Article #184 (1.76 oz. [50 g], 98 yds [90 m] each skein): 2 skeins of #00149 Orchid
- ✓ **Hook:** Crochet hook size K-10½ U.S. or size needed to obtain gauge
- ✓ **Yarn needle**
- ✓ **Measurement:** 21 in. in circumference
- ✓ **Gauge:** First 3 rnds = 3 in.
- ✓ **Stitches used:** Chain stitch (ch), slip stitch (sl st), double crochet (dc)

To crochet this hat, you start off with a small center ring, and by adding stitches incrementally in each round (increasing), you work until the desired diameter is reached. You then work even on the stitches to create the shape of the hat, and continue until the proper depth is reached. The brim is created by rolling the bottom few rolls up and sewing them into place. For more info on crocheting in rounds, see Chapter 4.

## *Directions*

**Center ring:** Ch 4 and close into a ring with 1 sl st in first ch.

**Rnd 1:** Ch 3 (first dc), work 7 dc in ring (8 dc), sl st in first dc to join.

**Rnd 2:** Ch 3 (first dc), dc in first dc, 2 dc in each dc around (16 dc), sl st in first dc to join.

**Rnd 3:** Ch 3 (first dc), dc in first dc, dc in next dc, • 2 dc in next dc, dc in next dc •, rep from • to • around (24 dc), sl st in first dc to join.

**Rnd 4:** Ch 3 (first dc), dc in first dc, dc in each of next 2 dc, • 2 dc in next dc, dc in each of next 2 dc •, rep from • to • around (32 dc), sl st in first dc to join.

**Rnd 5:** Ch 3 (first dc), dc in first dc, dc in each of next 3 dc, • 2 dc in next dc, dc in each of next 3 dc •, rep from • to • around (40 dc), sl st in first dc to join.

**Rnd 6:** Ch 3 (first dc), dc in first dc, dc in each of next 4 dc, • 2 dc in next dc, dc in each of next 4 dc •, rep from • to • around (48 dc), sl st in first dc to join.

**Rnd 7:** Ch 3 (first dc), dc in first dc, dc in each of next 5 dc, • 2 dc in next dc, dc in each of next 5 dc •, rep from • to • around (56 dc), sl st in first dc to join.

**Rnd 8:** Ch 3 (first dc), dc in first dc, dc in each of next 6 dc, • 2 dc in next dc, dc in each of next 6 dc •, rep from • to • around (64 dc), sl st in first dc to join.

**Rnds 9–16:** Ch 3 (first dc), dc in each dc around (64 dc), sl st in first dc to join.

**Rnd 17:** Ch 3 (first dc), dc in each dc around (64 dc), sl st in first dc to join. Fasten off.

**Brim:** With right side facing, roll last two rounds of hat up toward the outside, creating a rolled edge around the entire lower edge of hat. Using yarn needle and approximately 24 in. of yarn, sew last round of stitches to third round from bottom edge.





# Part III

## Putting Your Skills to the Test

The 5<sup>th</sup> Wave

By Rich Tennant

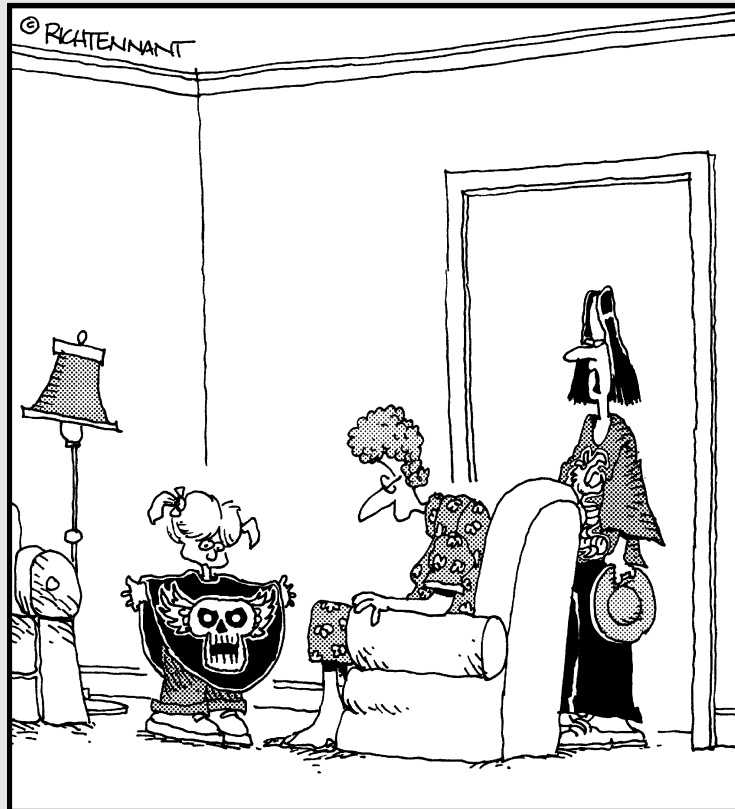

"Why should I invest in crochet patterns when my husband owns a tattoo parlor?"

## *In this part . . .*

**A**re you feeling adventurous? Ready to try something new? This part is just loaded with patterns that combine all of the basics and more. I've tried to include a little bit of everything here.

There's a chapter dedicated just to sweaters (although you'll find wearables in other chapters, too), and one that lets you practice stitch combinations while crocheting great accessories. Take a look at the chapter that includes filet crochet designs and projects using the afghan stitch. And for a really fun chapter, check out what you can make crocheting with nontraditional materials, such as wire and hemp. This same chapter introduces felting, which is really hot these days, and also offers a new take on the traditional granny square.

Browse through the projects and pick a few to try. All are unique, and they're not your grandmother's crochet!

## Chapter 10

# Seams Sew Easy: Joining Pieces Together

---

### *In This Chapter*

- ▶ Using furry squares to make a fun decorative pillow
  - ▶ Joining as you go to add length to a floral belt
  - ▶ Working up a warm winter vest
- 

**M**any crocheted items are comprised of several pieces joined together. The methods used to join these pieces are varied, and the method that you choose is largely dictated by the design and the type of yarn that you're using. For instance, the first pattern, the furry boa pillow, lends itself best to sewing, as does the third pattern, the southwest vest, because these two projects use a novelty yarn that can create a somewhat bulky seam when crocheted.

But the flower-power belt is created by joining each separate *motif* (a repeated figure in a design) as you go. When crocheting a design that's comprised of motifs, you generally have a lot of them. Joining them as you go saves time (you don't have to go back and sew everything together), and it also creates a neater seam. Many motifs lend themselves to a quick slip stitch in corresponding stitches across the edges to join.

Sewing separate pieces together creates a neater seam and works best in designs where you don't want the seam to be visible. On the other hand, crocheting a seam can be used as part of the design. For instance, when joining pieces of an afghan, you can use a crocheted seam not only to join the separate pieces, but to add color and dimension to the finished design.

This chapter allows you to practice two methods for joining pieces together and become familiar with why each is used. So pick a project, grab your hook and yarn, and get crocheting!

## *Furry Boa Pillow*

Pillows are a must-have for home décor — and if you walk through any store that carries home fashions, you'll see proof of this. This project gives you practice sewing pieces together (see Figure 10-1), and at the same time creates a pillow that rivals many that you see for sale — and at a fraction of the price. The yarn used is a very short, thick eyelash yarn with a strong base thread so it will stand up well to wear and tear. It's available in a variety of colors, so choose one that fits your color scheme.



**Figure 10-1:**  
The furry  
pillow is a  
must-have  
for your  
décor.

## *Materials and vital statistics*

- ✓ **Yarn:** Bernat “Boa” bulky-weight fur yarn (100% polyester), Article # 164081 (1.75 oz. [50 g], 71 yds [65 m] each ball): 6 balls of #81206 Toucan
- ✓ **Hook:** Crochet hook size K-10½ U.S. or size needed to obtain gauge
- ✓ **Yarn needle**
- ✓ **Pillow form:** 16 in. x 16 in.
- ✓ **Measurements:** 16 in. wide x 16 in. long
- ✓ **Gauge:** 10 sc = 4¼ in.; 10 rows = 4 in.
- ✓ **Stitches used:** Chain stitch (ch), single crochet (sc)

This design couldn’t be much easier. Crochet your foundation chain, and then work rows of single crochet stitches until your piece becomes a square. It may be slow going for the first row or two because of the furry nature of the yarn (sometimes it’s hard to see the stitches), but don’t give up. Count the stitches as you go so you don’t inadvertently drop any, and pretty soon you’ll be moving right along.

## *Directions*

Repeat these directions twice, once for the front and once for the back.

**Foundation chain:** Ch 43.

**Row 1 (right side):** Sc in 2nd ch from hook, sc in each ch across (42 sc), *turn*.

**Row 2:** Ch 1, sc in each sc across (42 sc), *turn*.

Rep Row 2 until piece measures 16 in. from beg. Fasten off.

**Assembly:** With the right sides of the front and back facing, using yarn needle and a length of yarn approximately 24 in. long, sew the pieces together using the whipstitch (see Appendix A for details on how to do this stitch) around three sides, matching stitches across each edge. Turn right side out. Insert pillow form between 2 pieces and sew remaining side closed.

## Flower-Power Belt

This floral design is popping up in all the stores (see Figure 10-2), so here it does double duty. Not only do you create this hot new fashion item, but you also practice the technique of joining motifs as you go. Although this pattern includes a new skill and probably falls within the intermediate skill level, it's really quick and easy to navigate. This project is a great stepping stone to prepare you for more-advanced patterns.

This joining method is used quite frequently and is accomplished by joining corresponding stitches on the current motif with those on the last motif made. It can consist of just a few stitches, such as this one, or it can be worked around four sides of a square motif. It's a great method if it can be used, and you save time because you don't have to sew a lot of pieces together when you're finished crocheting.



**Figure 10-2:**  
This belt  
gives you  
flower  
power  
to wear  
around your  
waist.

## Materials and vital statistics

- ✓ **Size:** Directions given are for size Small/Medium (48 in. in length). Changes for Large/X-Large (60 in. in length) are in parentheses.
- ✓ **Yarn:** Patons “Grace” sport-weight yarn (100% mercerized cotton), Article #246060 (1.75 oz. [50 g], 136 yds [125 m] each ball): 1 ball each of
  - #60005 Snow (A)
  - #60130 Sky (B)
  - #60104 Azure (C)
  - #60903 Lavender (D)
- ✓ **Hook:** Crochet hook size G-6 U.S. or size needed to obtain gauge
- ✓ **Measurements:** Motif = 3 in. in diameter
- ✓ **Gauge:** First rnd = 1¼ in.
- ✓ **Stitches used:** Chain stitch (ch), slip stitch (sl st), single crochet (sc), half double crochet (hdc), double crochet (dc)

The flower motifs that make up this belt illustrate a common method for creating flowers. There are many variations on this, but the principle is the same: Crochet a chain loop, and then fill it with stitches that graduate in height from shortest to tallest, then back down again. Joining the motifs is as easy as working a slip stitch into the corresponding stitch on the previous motif where designated.

## Directions

Make 4 (5) motifs of colors A, B, C, and D, working in the foll color sequence: A, B, C, D. (See Figure 10-3 for the stitch diagram.)

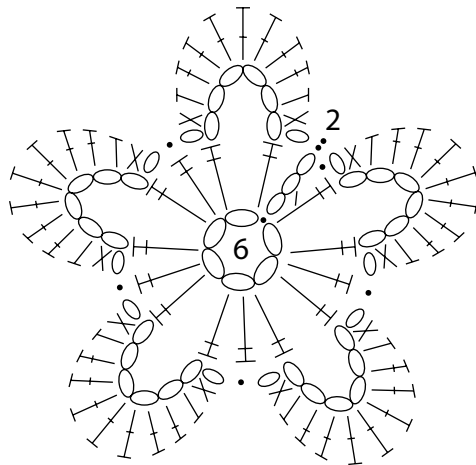

**Figure 10-3:**  
Motif stitch  
diagram.

### First motif

**Center ring:** With A, ch 6 and close into a ring with 1 sl st in first ch.

**Rnd 1:** Ch 3 (first dc), dc in ring, • ch 6, 3 dc in ring •, rep from • to • 3 times, ch 6, dc in ring, sl st in top of first dc (15 dc and 5 ch-6 loops).

**Rnd 2:** • Ch 1, (sc, hdc, 7 dc, hdc, sc) in next ch-6 loop, ch 1, skip next dc, sl st in next dc •, rep from • to • around (5 petals made). Fasten off.

### *Second and successive motifs*

**Center ring:** With next color in sequence, ch 6 and close into a ring with 1 sl st in first ch.

(See Figure 10-4 for a stitch diagram for joining motifs.)

**Rnd 1:** Ch 3 (first dc), dc in ring, • ch 6, 3 dc in ring •, rep from • to • 3 times, ch 6, dc in ring, sl st in top of first dc (15 dc and 5 ch-6 loops).

**Rnd 2:** • Ch 1, (sc, hdc, 7 dc, hdc, sc) in next ch-6 loop, ch 1, skip next dc, sl st in next dc •, rep from • to • around to within last petal, ch 1, (sc, hdc, 2 dc) in next ch-6 loop, with right sides facing, •• sl st in corresponding dc in last motif made, dc in ch-6 loop in current motif ••, rep from •• to •• twice, (2 dc, hdc, sc) in ch-6 loop in current motif, ch 1, skip next dc, sl st in next dc. Fasten off.

**Figure 10-4:**  
Stitch  
diagram for  
joining  
rounds for  
petals.

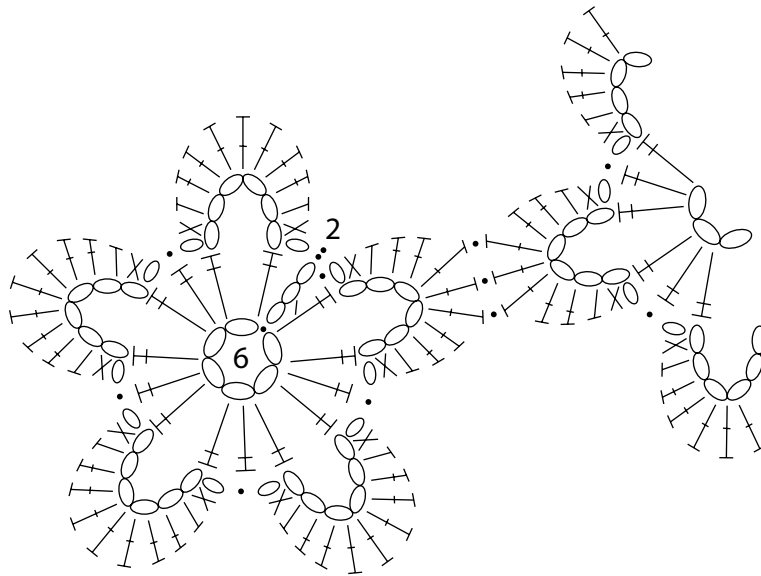

### *Variation: Choosing hues that fit your style*

This yarn comes in a multitude of colors, so feel free to choose your own combination, or use just a single color for a more subtle look.

## Southwest Vest

This vest is made with a wonderfully soft fur yarn in an unusual color combination (see Figure 10-5). The half double crochet stitch is nice and fat, so you don't have spaces between the stitches. There are no buttonholes, zippers, or belts to deal with, so you can just throw it on over a turtleneck and a pair of jeans, and you're ready for a brisk fall day.

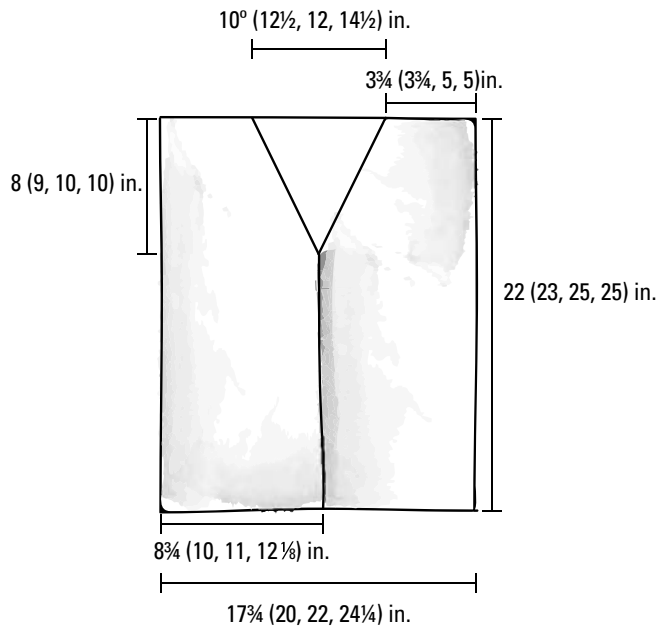

**Figure 10-5:** The southwest vest only requires sewing at the shoulders.

### Materials and vital statistics

- ✓ **Size:** Directions given are for size X-Small (4–6). Changes for Small (8–10), Medium (12–14), and Large (16) are in parentheses. Finished bust: 35¼ (40, 44, 48½) in. Back length: 22 (23, 25, 25) in. (See Figure 10-6 for measurements of specific project parts.)
- ✓ **Yarn:** South West Trading Company “Pagoda” bulky-weight yarn (100% polyester), (3.5 oz. [100 g], 110 yds [101 m] each skein): 5 (5, 6, 6) skeins of #311 Bear Cub
- ✓ **Hook:** Crochet hook size L-11 U.S. or size needed to obtain gauge.
- ✓ **Yarn needle**
- ✓ **Gauge:** 10 hdc = 5½ in.; 9 rows hdc = 5 in.
- ✓ **Stitches used:** Chain stitch (ch), slip stitch (sl st), half double crochet (hdc). **Dec 1 hdc:** • Yo, (insert hook in next st, yo, draw yarn through st) twice, yo, draw yarn through 4 loops on hook •.





**Figure 10-6:**  
Schematic  
for the vest.

The construction of this vest couldn't be much simpler: The whole thing is worked in one piece from the bottom edge to the armholes. The work is then split into the two sides of the front and the back by skipping stitches to create the armhole openings. The only sewing required is to sew the shoulder seams.

The first couple of rows worked with this yarn can be slow going, but after you've gotten three to four of them done, the work becomes much easier.

## Directions

**Foundation chain:** Ch 63 (71, 79, 87) + 2 (first hdc).

**Row 1 (right side):** Hdc in 3rd ch from hook, hdc in each ch across (64 [72, 80, 88] hdc), *turn*.

**Row 2:** Ch 2 (first hdc), hdc in each hdc across (64 [72, 80, 88] hdc), *turn*.

Rep Row 2 until piece measures 14 (14, 15, 15) in. from beg, ending with a wrong-side row.

### Shape right front

**Next Row:** Ch 2 (first hdc), hdc in each of next 14 (16, 18, 20) hdc (15 [17, 19, 21] hdc), *turn*, leaving rem sts unworked.

**Next Row:** Ch 2 (first hdc), hdc in each hdc across to within last 2 hdc, dec 1 hdc in last 2 hdc (14 [16, 18, 20] hdc), *turn*.

**Next Row:** Ch 2 (first hdc), dec 1 hdc in next 2 hdc, hdc in each hdc across (13 [15, 17, 19] hdc), *turn*.

Rep last 2 rows until 7 (7, 9, 9) sts rem on work.

Work even in hdc until right front measures 8 (9, 10, 10) in. from beg of shaping.  
Fasten off.

### ***Back***

**Next Row:** With right side facing, skip next 2 sts to the left of last st made in first row of right front, join yarn in next st, ch 2 (first hdc), hdc in each of next 29 (33, 37, 41) hdc (30 [34, 38, 42] hdc), *turn*, leaving rem sts unworked.

Work even in hdc across 30 (34, 38, 42) hdc until back measures same as finished front.  
Fasten off.

### ***Shape left front***

**Next Row:** With right side facing, skip next 2 sts to the left of last st made in first row of back, join yarn in next st, ch 2 (first hdc), hdc in each hdc across (15 [17, 19, 21] hdc), *turn*.

**Next Row:** Ch 2 (first hdc), dec 1 hdc in next 2 hdc, hdc in each hdc across (14 [16, 18, 20] hdc), *turn*.

**Next Row:** Ch 2 (first hdc), hdc in each hdc across to within last 2 hdc, dec 1 hdc in last 2 hdc (13 [15, 17, 19] hdc), *turn*.

Rep last 2 rows until 7 (7, 9, 9) sts rem on work.

Work even in hdc until left front measures 8 (9, 10, 10) in. from beg of shaping.  
Fasten off.

### ***Assembly***

Turn the vest inside out so the right sides are facing each other, and using the yarn needle and a 12-in. length of yarn, use the whipstitch to sew the fronts to the back across the shoulders, beginning at the armhole edge, matching stitches across.

## ***Variation: Belt it!***

If you'd like to have a vest that you can cinch, the easiest way is to make a belt.

Make a foundation chain long enough to fit around your waist, then add about 18 in. Work 3 rows of single crochet stitches to complete the belt, or more if you'd like it a bit wider.

## Chapter 11

# Finding the Loopholes and Creative Combinations

---

### *In This Chapter*

- ▶ Working in the spaces to create an elegant wrap
  - ▶ Creating a belt in crossed double crochet stitch for an up-to-date accessory
  - ▶ Throwing a loop into your stitches to create a standout scarf
  - ▶ Revisiting the V-stitch with a fashion-forward wrap
- 

**D**o you want to know why crocheting is unique when compared to the other needlework arts? Because after you've gotten the hang of the basic stitches, you can combine them in simple ways to create totally different looks. Using only the chain stitch, slip stitch, single crochet stitch, and double crochet stitch, you can add a plethora of stitch patterns to your skill library.

The patterns in this chapter give you a chance to practice these frequently used combinations while creating designs you'll be proud to show off.

## *Elegant Evening Wrap*

Many of us love to have a wrap around because you can take it on and off easily and you can wear it with countless outfits (see Figure 11-1). The yarn I suggest here is actually a combination of three strands of yarn wound together to create one, with rich browns, coppers, and gold eyelash included.

When crocheting with some of these newer novelty yarns, you may have some difficulty working into the stitches, so a design such as this one is especially well-suited to these yarns. The spaces are easy to see, the pattern is light and airy, and the strands of fur and eyelashes fill in the spaces.



**Figure 11-1:**

The yarn and stitch pattern turns a simple wrap into one that's elegant enough to wear just about anyplace.

## Materials and vital statistics

- ✓ **Yarn:** Ironstone Yarns “Showstopper” bulky-weight yarn (1 strand each of Paris Nights, Eyelash, and Mohair), (4.3 oz. [123 g], 100 yds [91 m] each hank): 5 hanks of #2 copper/rust/brown
- ✓ **Hook:** Crochet hook size L-11 U.S. or size needed to obtain gauge
- ✓ **Measurements:** 20 in. wide x 69½ in. long, excluding fringe
- ✓ **Gauge:** 10 sts in pat = 4 in.; 5 rows in pat = 4 in.
- ✓ **Stitches used:** Chain stitch (ch), double crochet (dc)

This is a fairly common stitch pattern, using only the chain stitch and double crochet stitch. The pattern is really nice when working with textured yarns because you don't necessarily have to see the tops of the stitches. The stitches in the current row are worked into the chain spaces created in the previous row, which also makes it really fast to crochet.

## Directions



Sometimes it's easier to “see” with your fingers. Let your fingers feel for the next space to stick your hook into.

**Foundation chain:** Ch 49 + 3 (first dc).

(See Figure 11-2 for a stitch diagram.)

**Row 1:** Dc in 4th ch from hook, • ch 1, skip next ch, dc in next ch •, rep from • to • across (26 dc and 24 ch-1 spaces), *turn*.

**Row 2:** Ch 3 (first dc), • dc in next ch-1 space, ch 1, skip next dc •, rep from • to • across, dc in first dc (26 dc and 24 ch-1 spaces), *turn*.

**Rows 3–86:** Ch 3 (first dc), • dc in next ch-1 space, ch 1, skip next dc •, rep from • to • across, dc in first dc (26 dc and 24 ch-1 spaces), *turn*.

**Row 87:** Ch 3 (first dc), • dc in next ch-1 space, ch 1, skip next dc •, rep from • to • across, dc in first dc (26 dc and 24 ch-1 spaces). Fasten off.

**Figure 11-2:**  
Stitch  
diagram  
of wrap  
pattern.

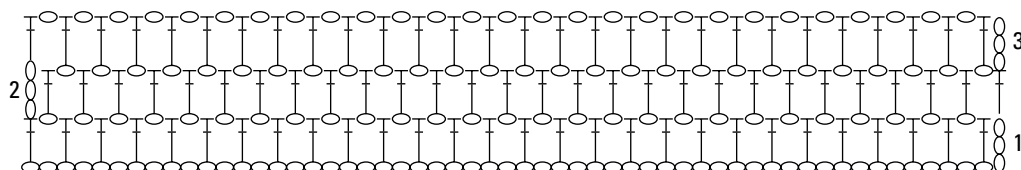

**Fringe:** Cut 50 24-in. lengths of yarn. Using one length for each fringe, single knot one fringe in each ch-1 space and between the last 2 dc across each short edge of wrap (see Appendix A for fringe how-to's).

## Double-Crossing Belt

Everyone is wearing belts these days, and you see them in all sorts of styles and materials. Based on the name, you may think that this belt can be wrapped around you twice, but the name is actually based on the name of the stitch combination used. You rely on the half double crochet stitch and throw in some crossed double crochet stitches every couple of inches (see Figure 11-3).



**Figure 11-3:**  
The creative  
order  
of basic  
crochet  
stitches  
gives this  
belt a  
unique look.

What's a crossed double crochet stitch, you ask? It's nothing more than double crochet stitches worked out of order. By doing so, you create an X-shaped pattern that is slightly raised. The crochet thread used in this project is available in a wide range of colors, so if your wardrobe doesn't call for a white belt, choose your own color.

## Materials and vital statistics

- ✓ **Size:** Directions are for size X-Small. Changes for Small, Medium, Large, X-Large, and XX-Large are in parentheses. Finished waist: 34 (36, 38, 40, 42, 44) in.
- ✓ **Yarn:** Aunt Lydia's Fashion Crochet Thread size 3 crochet cotton (100% mercerized cotton), Article #182 (150 yds [137 m] each ball): 2 balls of #926 Bridal White
- ✓ **Hook:** Crochet hook size E-4 U.S. or size needed to obtain gauge
- ✓ **Belt buckle:** Dritz Glamour Rings, 2½ in., gold
- ✓ **Tapestry needle**
- ✓ **Measurements:** 2 in. wide x 34 (36, 38, 40, 42, 44) in. long
- ✓ **Gauge:** 5 sts and 4 rows hdc = 1 in.
- ✓ **Stitches used:** Chain stitch (ch), single crochet (sc), half double crochet (hdc), double crochet (dc), triple crochet (tr). **Crossed dc:** Skip next st, dc in next st, working behind dc just made, dc in last skipped st.



When determining which size to make, measure your waist (or hips, depending on where you'll wear the belt), and add approximately 3 inches to get your finished size.

To work the crossed double crochet stitch, you simply jump around a bit when you stitch the double crochet stitches. Instead of working them straight across a row, you simply skip a stitch, work your double crochet stitch, and then go back and work a double crochet stitch in the skipped stitch. The stitch diagram in Figure 11-4 gives you an idea of what stitches to make where. If you want more-detailed instructions on making the crossed double crochet stitch, flip to Appendix A.

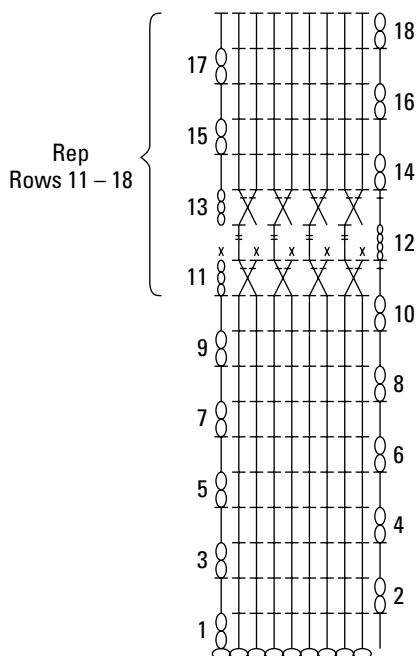

**Figure 11-4:**  
Stitch  
diagram of  
belt pattern.

## Directions

**Foundation chain:** Ch 9 + 2 (first hdc).

(See Figure 11-4 for a stitch diagram.)

**Row 1 (wrong side):** Hdc in 3rd ch from hook, hdc in each ch across (10 hdc), *turn*.

**Row 2 (right side):** Ch 2 (first hdc), hdc in each hdc across (10 hdc), *turn*.

**Rows 3–10:** Rep Row 2.

**Row 11:** Ch 3 (first dc), • skip next hdc, dc in next hdc, working behind dc just made, dc in skipped hdc (crossed dc made) •, rep from • to • across to within last hdc, dc in last hdc (10 dc), *turn*.

**Row 12:** Ch 4 (first tr), • sc in next dc, tr in next dc •, rep from • to • across to within last dc, sc in last dc (10 sts), *turn*.

**Row 13:** Ch 3 (first dc), • skip next tr, dc in next sc, working behind dc just made, dc in skipped tr (crossed dc made) •, rep from • to • across to within last tr, dc in last tr (10 sts), *turn*.

**Rows 14–18:** Ch 2 (first hdc), hdc in each st across (10 hdc), *turn*.

Rep Rows 11–18 for pat until belt reaches 35 (37, 39, 41, 43, 45) in. in length. Fasten off.

**Finishing:** With wrong side facing, draw Foundation row through both belt rings and fold over, matching Foundation row to Row 10. With tapestry needle and 12-in. length of yarn, sew Foundation row to Row 10, matching sts across.

## Love Those Loops Scarf

Throw a loop into your wearable accessories with this design. The loop stitch used to create the texture in this standout scarf is actually a variation of the single crochet. The loops appear on the “wrong” side of the fabric, but because you work the stitch in consecutive rows, the loops show up on both sides of the scarf (see Figure 11-5).



**Figure 11-5:**  
Your friends  
will go loopy  
over this fun  
scarf.

## *New skill: The loop stitch*

When working the loop stitch, the most important thing is to try to get your loops uniform in size. There really is no standard size, but they should be somewhere around an inch long. If your loops vary in size across each row, it can tend to look a little messy. When working your gauge swatch, which is a great way to practice this stitch as well, you'll probably find that you tend to create the loops at a certain length. Don't try to change this, just concentrate on making them all the same. If you find that your loops are disappearing as you crochet subsequent rows, don't worry about it. When you're finished, just go back and give them a gentle tug, and they'll reappear as good as new.

To make a loop stitch:

1. Using the index finger of your yarn hand to control the loop size, wrap the yarn from front to back over your index finger, and insert your hook in the next stitch (see Figure 11-6a).
2. Pick up both threads of the loop and draw through stitch (3 loops on hook) (see Figure 11-6b).
3. Yarn over, and draw yarn through the 3 loops on your hook.

Figure 11-6c shows a completed loop stitch.

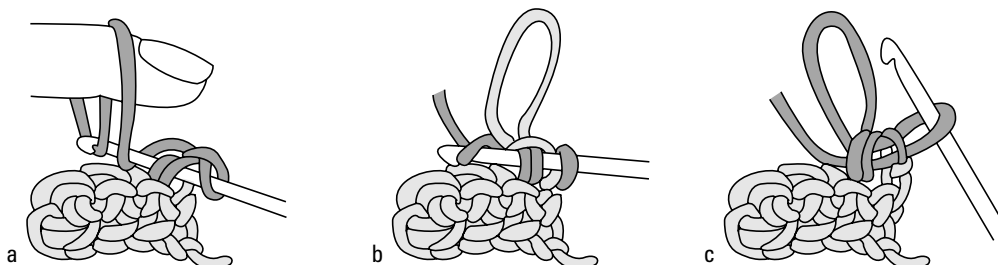

**Figure 11-6:**  
The three  
steps to  
creating a  
loop stitch.





Make sure to work a practice swatch so you can get the hang of the stitch. It may take a little time to get the loops uniform in size, but the end result is well worth it.

## Materials and vital statistics

- ✓ **Yarn:** Caron “Simply Soft Brites” worsted-weight yarn (100% acrylic), Article #H9700B (6 oz. [170 g], 330 yds [302 m] each skein): 1 skein of #9605 Mango
- ✓ **Hook:** Crochet hook size J-10 U.S. or size needed to obtain gauge
- ✓ **1½ in. pompom maker (optional)**
- ✓ **Measurements:** 4 in. wide x 49 in. long, excluding pompoms
- ✓ **Gauge:** 10 loop sts and 10 rows = 3 in.
- ✓ **Stitches used:** Chain stitch (ch), single crochet (sc), loop stitch (see the “New skill: The loop stitch” section)

Crocheting the loop stitch may seem intimidating, but it’s not hard. The stitch is simply a version of the single crochet. Instead of pulling your yarn tight as you draw it through the stitch, you leave a loop hanging on the wrong side. This design is worked by crocheting rows of the loops stitch, separated by several rows of single crochet, and finishing it off with fun pompoms on each corner.

## Directions

**Foundation chain:** Ch 13.

**Row 1 (right side):** Sc in 2nd ch from hook, sc in each ch across (12 sc), *turn*.

**Rows 2–11:** Ch 1, work one loop st in each st across (12 loop sts), *turn*.

**Rows 12–19:** Ch 1, sc in each st across (12 sc), *turn*.

Rep Row 2–19 ten times or until scarf measures 3 in. less than desired length.

Rep Rows 2–11 one time.

**Last Row:** Ch 1, sc in each st across (12 sc). *Do not turn*.

**Edging:** Working in row-end sts across long edge of scarf, sc evenly across long edge to next corner, 3 sc in corner st, sc in each st across short edge to next corner, 3 sc in corner st, working in row-end sts across next long edge, sc evenly across long edge to next corner, sl st to join. Fasten off.

**Optional finishing:** Make four 1½-in. pompoms with pompom maker. Loosely tie one pompom to each corner on each short edge of scarf.

### *Variation: Adding more loops*

If you're looking for more loops, then you've come to the right place. In the main pattern, each section of loops is separated with sections of single crochet stitches. Here, you omit the single crochet sections and just keep going with the loops. To be on the safe side, pick up an extra skein of yarn so you can be sure not to run out.

**Foundation chain:** Ch 13.

**Row 1 (right side):** Sc in 2nd ch from hook, sc in each ch across (12 scs), *turn*.

**Row 2:** Ch 1, work one loop st in each st across (12 loop sts), *turn*.

Rep Row 2 until scarf reaches 49 in. or desired length.

**Last row:** Ch 1, sc in each st across (12 sc). *Do not turn*.

**Edging:** Working in row-end sts across long edge of scarf, sc evenly across long edge to next corner, 3 sc in corner st, sc in each st across short edge to next corner, 3 sc in corner st, working in row-end sts across next long edge, sc evenly across long edge to next corner, sl st to join. Fasten off.

**Optional finishing:** Make four 1½-in. pompoms with pompom maker. Loosely tie one pompom to each corner on each short edge of scarf.

### *Variation: Fashioning a furry look*

Turn your loops into fur! When you're finished crocheting, cut the loops in two to create a fur-like fabric. Don't worry about the stitches falling apart. Each stitch is secured as it's made, so you won't end up with a bunch of short pieces of yarn.

### *Variation: Swapping yarns*

This scarf would also look wonderful made with a softly textured yarn such as a mohair blend. You can also tone it down by using a more subtle color.

## *Geometric Wrap*

If you take a look around you when you go to the mall, or almost any clothing store for that matter, you're bound to see a design such as the one in this wrap (see Figure 11-7). Worked in the shape of a triangle, the V-stitch, which is comprised of two double crochet stitches joined by a chain stitch, creates an open and lacy pattern that makes this wrap ideal for when there's a touch of chill in the air. The yarn adds a slight shimmer and is available in several colors. If you don't want to wear it as a wrap, go for the modern look and wrap it around your waist (sideways, of course) as a great accent to a pair of jeans.



**Figure 11-7:**

You can wear the geometric wrap traditionally or wrapped around your waist.

## Materials and vital statistics

- ✓ **Size:** One size fits most adults
- ✓ **Yarn:** Aunt Lydia's "Shimmer Fashion" fine sport-weight yarn (64% cotton/36% rayon), Article #188 (2 oz. [57 g], 124 yds [113 m] each ball): 5 balls of #2242 Light Linen
- ✓ **Hook:** Crochet hook size I-9 U.S. or size needed to obtain gauge
- ✓ **Measurements:** 31½ in. from bottom point to top edge; 45 in. across top edge
- ✓ **Gauge:** 7 V-sts = 5 in.; 10 rows in pat = 5 in.
- ✓ **Stitches used:** Chain stitch (ch), double crochet (dc). **V-stitch:** (Dc, ch 1, dc) in same st or space. (For a quick reminder on how to create a V-stitch, refer to Appendix A.)

Because the V-stitch creates an open fabric, watch where you put your hook. Make sure to work your next row of stitches in the space created by the chain-one stitch of the V-stitch directly below it, and not between the V-stitches themselves (see Figure 11-8). The triangle shape of this pattern is created by starting with a single V-stitch, then increasing them as you go along. The increases take place across two rows, in this case Rows 4 and 5, until you reach the desired width.

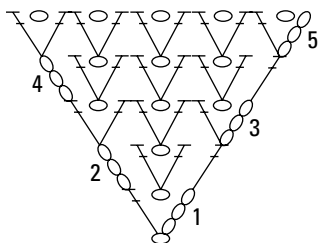

**Figure 11-8:**  
Reduced sample of stitch pattern.

## Directions

**Foundation chain:** Ch 2 + 3 (first dc).

(See Figure 11-8 for a reduced sample of the stitch pattern.)

**Row 1 (right side):** Dc in 5th ch from hook (1 V-st), *turn*.

**Row 2:** Ch 3 (first dc), V-st in next ch-1 space, dc in last dc (1 V-st and 2 dc), *turn*.

**Row 3:** Ch 3 (first dc), (ch 1, dc) in first dc, V-st in next ch-1 space, V-st in last dc (3 V-sts), *turn*.

**Row 4:** Ch 3 (first dc), V-st in each ch-1 space across, dc in last dc (3 V-sts and 2 dc), *turn*.

**Row 5:** Ch 3 (first dc), (ch 1, dc) in first dc, V-st in each ch-1 space across, V-st in last dc (5 V-sts), *turn*.

**Rows 6–63:** Rep Rows 4–5 (29 times) (63 V-sts at end of last row). Fasten off.

**Fringe:** Cut yarn into 130 9-in. lengths. Using 2 strands of yarn held together as one for each fringe, starting at the bottom point of wrap, single-knot one fringe in bottom point, then in every even-numbered row across sides of wrap. Trim ends even. (See Appendix A for more info on fringe.)



When cutting yarn for fringe, try to find something to wrap the yarn around that will produce the lengths you need. You might try a book, a sturdy piece of cardboard, a CD case, and so on.

## Variation: Why knot add beads?

For a different twist, add some beads to the fringe. Just keep them small and light so they don't add too much weight.

## Chapter 12

# Sensational Sweaters

---

### *In This Chapter*

- ▶ Working vertically to create a winter tunic
  - ▶ Layering with a light bolero
  - ▶ Pulling off a pullover
  - ▶ Staying cool with a tank top
  - ▶ Warming up with a stylish jacket
- 

**F**or as long as I can remember, whenever I would mention crochet to people, they would get a funny look on their face, and I could almost see them thinking about all the doilies, afghans, tablecloths, and other yarn stuff scattered around their grandmother's house. Fortunately, people now realize that crochet projects go way beyond home décor items. Crochet is hot, especially when it comes to garments. You can see crocheted sweaters, jackets, and tops on the runways at all the major fashion shows, and you can't go into a clothing store without seeing clothes either entirely crocheted or at least embellished with it. And then, of course, you have all sorts of crocheted accessories.

This chapter provides you with five patterns to crochet your own sweaters, from warm winter pullovers to lacy tops. Just think how great you'll feel when someone asks you where you bought your top and you can tell them, "I made it!"

## *Vertical Stripes Tunic*

Everyone knows that vertical stripes are flattering. Combine this concept with dark tones, and you've got a sweater that's not only pretty and warm, but one that makes you look great as well (see Figure 12-1). When the cold weather comes in, this is definitely a sweater to reach for.

Instead of working in rows from bottom to top as is typically done, you crochet this sweater vertically. Because this method is different from normal crocheting, this tunic is best tackled after you've mastered the basic crochet skills and are ready to move on to intermediate-level projects. That doesn't make the method any more difficult; it's just different. You'll come across sweaters worked this way from time to time, and after crocheting this one, you'll know just what to expect.

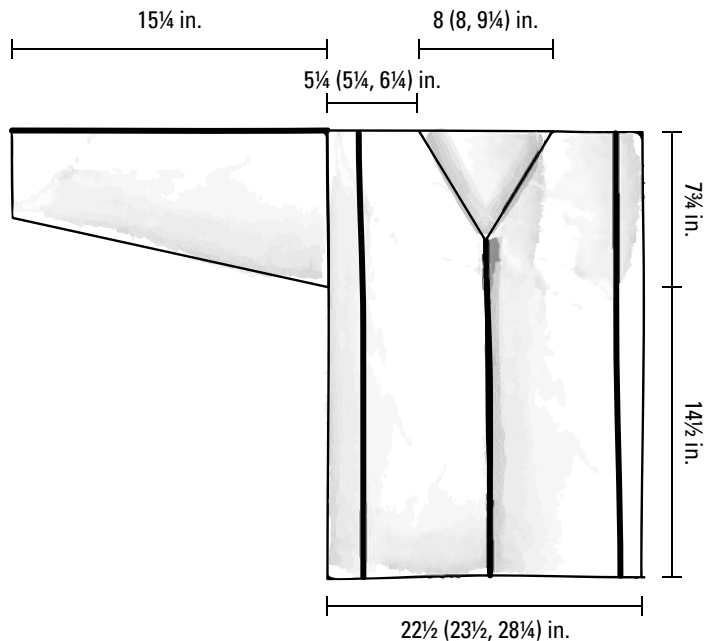

**Figure 12-1:**  
The warm and cozy winter tunic requires you to think vertical instead of horizontal.

## *Materials and vital statistics*

- ✓ **Size:** Directions are for size Small (4–6). Changes for Medium (8–10) and Large (12–14) are in parentheses. **Note:** This is an oversized garment.
- ✓ **Yarn:** Caron “Bliss” bulky-weight yarn (60% acrylic/40% nylon), Article #BL1000 (1.75 oz. [50 g], 82 yds [75 m] each ball):
  - 13 (14, 15) balls of #0013 Black (MC)
  - 2 balls of #0015 Fiesta (CC)
- ✓ **Hook:** Crochet hook size K-10½ U.S. or size needed to obtain gauge
- ✓ **Tapestry needle**
- ✓ **Measurements:** Finished bust: 45 (47, 56½) in. Back length: 22¼ in. Sleeve length: 15¼ in. Figure 12-2 shows finished measurements.
- ✓ **Gauge:** 10 hdc = 3 in.; 10 rows = 5¾ in.
- ✓ **Stitches used:** Chain stitch (ch), slip stitch (sl st), half double crochet (hdc)

The design of this sweater is atypical, although not uncommon. Sweaters are usually worked in horizontal rows starting at the bottom edge and working up to the neck edge, but not this one. Instead, you work in vertical rows starting at one side edge and working across the front, shaping the armholes and neck as you go. There’s really only one stitch involved, the half double crochet, and a couple of color-changing rows, so you can concentrate on the design without having to worry about complicated stitch patterns. (If you need a refresher on changing colors, head to Chapter 4.)



**Figure 12-2:**  
Schematic  
for the tunic.

## Starting with the front

**Foundation chain:** With MC, ch 47 + 2 (first hdc).

**Row 1 (right side):** Hdc in 3rd ch from hook, hdc in each ch across (48 hdc), *turn*.

**Row 2:** Ch 2 (first hdc), hdc in each hdc across (48 hdc), *turn*.

Rep Row 2 (1 [2, 3] times). *Do not turn* at end of last row.

### Beg shoulder

**Next Row:** Ch 27, *turn*, hdc in 3rd ch from hook, hdc in each ch across, hdc in each hdc across (74 hdc), *turn*.

Work even in hdc across 74 sts for 2 (2, 3) more rows. Fasten off MC, join CC.

**Next Row:** With CC, hdc in each hdc across (74 hdc), *turn*. Fasten off CC, join MC.

**Next Row:** With MC, hdc in each hdc across (74 hdc), *turn*. Fasten off MC, join CC.

**Next Row:** With CC, hdc in each hdc across (74 hdc), *turn*. Fasten off CC, join MC.

With MC, work even in hdc for 3 (3, 4) rows.

### Shape neck

**Next Row:** With MC, hdc in each hdc across, dec 1 st at neck edge on each of next 6 (6, 7) rows (68 [68, 67] hdc at end of last row). Fasten off MC, join CC.

**Next Row:** With CC, hdc in each hdc across, dec 1 hdc at neck edge (67 [67, 66] hdc), *turn*. Fasten off CC, join MC.

**Next Row:** With MC, hdc in each hdc across (67 [67, 66] hdc), *turn*. Fasten off MC, join CC.

**Next Row:** With CC, hdc in each hdc across, inc 1 st at neck edge (68 [68, 67] hdc), *turn*. Fasten off CC, join MC.

With MC, hdc in each hdc across, inc 1 st at neck edge on each of next 6 (6, 7) rows (74 [74, 74] hdc at end of last row).

With MC, work even across 74 hdc for 3 (3, 4) rows. Fasten off MC, join CC.

**Next Row:** With CC, hdc in each hdc across (74 hdc), *turn*. Fasten off CC, join MC.

**Next Row:** With MC, hdc in each hdc across (74 hdc), *turn*. Fasten off MC, join CC.

**Next Row:** With CC, hdc in each hdc across (74 hdc), *turn*. Fasten off CC, join MC.

With MC, work even across 74 hdc for 3 (3, 4) rows.

### ***Shape armhole***

**Next Row:** Hdc in each of next 47 hdc (48 [48, 48] hdc), *turn*, leaving 26 sts at shoulder unworked.

Work even in hdc across 48 sts for 2 (3, 4) more rows. Fasten off.

## ***Turning to the back***

**Foundation chain:** With MC, ch 47 + 2 (first hdc).

**Row 1 (right side):** Hdc in 3rd ch from hook, hdc in each ch across (48 hdc), *turn*.

**Row 2:** Ch 2 (first hdc), hdc in each hdc across, hdc in top of turning ch (48 hdc), *turn*.

Rep Row 2 (1 [2, 3] times). *Do not turn* at end of last row.

### ***Beg shoulder***

**Next Row:** Ch 27, *turn*, hdc in 3rd ch from hook, hdc in each ch across, hdc in each hdc across (74 hdc), *turn*.

Work even in hdc across 74 sts for 2 (2, 3) more rows. Fasten off MC, join CC.

**Next Row:** With CC, hdc in each hdc across (74 hdc), *turn*. Fasten off CC, join MC.

**Next Row:** With MC, hdc in each hdc across (74 hdc), *turn*. Fasten off MC, join CC.

**Next Row:** With CC, hdc in each hdc across (74 hdc), *turn*. Fasten off CC, join MC.

With MC, work even in hdc for 3 (3, 4) rows.

### ***Shape neck***

**Next Row:** With MC, hdc in each hdc across, dec 1 st at neck edge (73 hdc), *turn*.

Work even across 73 hdc for 5 (5, 6) more rows. Fasten off MC, join CC.



**Next Row:** With CC, hdc in each hdc across, (73 hdc), *turn*. Fasten off CC, join MC.

**Next Row:** With MC, hdc in each hdc across (73 hdc), *turn*. Fasten off MC, join CC.

**Next Row:** With CC, hdc in each hdc across, (73 hdc), *turn*. Fasten off CC, join MC.

With MC, hdc in each hdc across for 5 (5, 6) rows (73 hdc), *turn*.

**Next Row:** Hdc in each hdc across, inc 1 st at neck edge (74 hdc), *turn*.

With MC, work even in hdc for 3 (3, 4) rows. Fasten off MC, join CC.

**Next Row:** With CC, hdc in each hdc across (74 hdc), *turn*. Fasten off CC, join MC.

**Next Row:** With MC, hdc in each hdc across (74 hdc), *turn*. Fasten off MC, join CC.

**Next Row:** With CC, hdc in each hdc across (74 hdc), *turn*. Fasten off CC, join MC.

With MC, work even across 74 hdc for 3 (3, 4) rows.

### ***Shape armhole***

**Next Row:** Hdc in each of next 47 hdc (48 [48, 48] hdc), *turn*, leaving 26 sts at shoulder unworked.

Work even in hdc across 48 sts for 2 (3, 4) more rows. Fasten off.

## ***Moving on to the sleeves***

**Note:** You need to make two of these.

**Foundation chain:** With MC, ch 29 + 2 (first hdc).

**Row 1:** Hdc in 3rd ch from hook, hdc in each ch across (30 hdc), ch 4, *turn*.

**Row 2:** Hdc in 3rd ch from hook, hdc in next ch, hdc in each hdc across, (33 hdc), *turn*.

**Row 3:** Hdc in each hdc across (33 hdc), ch 4, *turn*.

**Row 4:** Hdc in 3rd ch from hook, hdc in next ch, hdc in each hdc across, (36 hdc), *turn*.

**Row 5:** Hdc in each hdc across (36 hdc), ch 4, *turn*.

**Row 6:** Hdc in 3rd ch from hook, hdc in next ch, hdc in each hdc across, (39 hdc), *turn*.

**Row 7:** Hdc in each hdc across (39 hdc), ch 4, *turn*.

**Row 8:** Hdc in 3rd ch from hook, hdc in next ch, hdc in each hdc across, (42 hdc), *turn*.

**Row 9:** Hdc in each hdc across (42 hdc), ch 4, *turn*.

**Row 10:** Hdc in 3rd ch from hook, hdc in next ch, hdc in each hdc across, (45 hdc), *turn*.

**Row 11:** Hdc in each hdc across (45 hdc), ch 4, *turn*.

**Row 12:** Hdc in 3rd ch from hook, hdc in next ch, hdc in each ch across, (48 hdc), *turn*.

**Row 13:** Hdc in each hdc across (48 hdc), ch 4, *turn*.

**Row 14:** Hdc in 3rd ch from hook, hdc in next ch, hdc in each hdc across (51 hdc), *turn*.

**Rows 15–20:** Hdc in each hdc across (51 hdc), *turn*. Fasten off MC, join CC.

**Row 21:** With CC, hdc in each hdc across (51 hdc), *turn*. Fasten off CC, join MC.

**Row 22:** With MC, hdc in each hdc across (51 hdc), *turn*. Fasten off MC, join CC.

**Row 23:** With CC, hdc in each hdc across (51 hdc), *turn*. Fasten off CC, join MC.

**Rows 24–29:** With MC, hdc in each hdc across (51 hdc), *turn*.

**Row 30:** Sl st in each of first 3 sts, ch 2 (first hdc), hdc in each hdc across (48 hdc), *turn*.

**Row 31:** Hdc in each hdc across (48 hdc), *turn*.

**Row 32:** Sl st in each of first 3 sts, ch 2 (first hdc), hdc in each hdc across (45 hdc), *turn*.

**Row 33:** Hdc in each hdc across (45 hdc), *turn*.

**Row 34:** Sl st in each of first 3 sts, ch 2 (first hdc), hdc in each hdc across (42 hdc), *turn*.

**Row 35:** Hdc in each hdc across (42 hdc), *turn*.

**Row 36:** Sl st in each of first 3 sts, ch 2 (first hdc), hdc in each hdc across (39 hdc), *turn*.

**Row 37:** Hdc in each hdc across (39 hdc), *turn*.

**Row 38:** Sl st in each of first 3 sts, ch 2 (first hdc), hdc in each hdc across (36 hdc), *turn*.

**Row 39:** Hdc in each hdc across (36 hdc), *turn*.

**Row 40:** Sl st in each of first 3 sts, ch 2 (first hdc), hdc in each hdc across (33 hdc), *turn*.

**Row 41:** Hdc in each hdc across (33 hdc), *turn*.

**Row 42:** Sl st in each of first 3 sts, ch 2 (first hdc), hdc in each hdc across (30 hdc), *turn*.

**Row 43:** Hdc in each hdc across (30 hdc), *do not turn*.

### ***Seam edging***

Working in row-end sts toward cuff edge of sleeve, • hdc in base of “step,” sl st in top of “step” •, rep from • to • across to next corner. Fasten off. Repeat on other side edge.

## *Putting the pieces together*

When sewing the pieces of this sweater together, use the whipstitch (see Appendix A for detailed instructions). With right sides facing, using yarn needle and MC, sew front to back across shoulders. With right sides of sleeves facing in, fold sleeves in half lengthwise. Matching the center fold to the shoulder seam, sew each sleeve in place. Beginning at the lower edge of each side seam, leaving first 3 inches free, matching stitches, sew side seams from lower edge to underarm. Sew underarm and sleeve seams.

## *Lacy Bolero*

This top is really fun. With its open, lacy design, you can wear this bolero anywhere and any time (see Figure 12-3). Layer it over your favorite top — long or short sleeve, it doesn't matter — and you'll have an eye-catching look.



**Figure 12-3:**

The lacy bolero adds a trendy look to your wardrobe.

The stitch pattern and shaping involved make this a more intermediate-level pattern, but it's nothing that you can't tackle. After you're done with this, take a look at the designs displayed in the stores, and you'll realize that it's not so hard after all. Then you can make your own instead of buying them. This design is fun, so go ahead and make a few. Use different colors to match your wardrobe, or whip up a couple for those teens in your life!

## Materials and vital statistics

- ✓ **Size:** Directions are for size Small/Medium (4–8). Changes for Medium/Large (10–14) are in parentheses.
- ✓ **Yarn:** Fiesta Yarns “La Luz” sport-weight yarn (100% silk), (2 oz. [50 g], 220 yds [201 m] each hank): 3 (4) hanks of #3307 Cherry
- ✓ **Hook:** Crochet hook size G-6 U.S. or size needed to obtain gauge
- ✓ **Tapestry needle**
- ✓ **Measurements:** Finished bust: 30–34 (36–40) in. Back length: 12 in. Sleeve length: 4½ in. Figure 12-4 shows finished measurements.
- ✓ **Gauge:** 3 shells in pat = 4½ in.; 9 rows in pat = 4 in.
- ✓ **Stitches used:** Chain stitch (ch), slip stitch (sl st), single crochet (sc), double crochet (dc). **Shell:** • (Dc, ch 2, 4 dc) in same stitch or space •.



Because of the design, the fit of this garment is very forgiving. The front ties allow you to adjust the front fit.

This fun little top is a great way to practice working a lacy stitch pattern. You start out with a long foundation chain that sets the width for the top including the front ties (don't worry — the top isn't this big across!). You then skip a bunch of stitches from the end and begin to work the body of the top. This is then split to separate the fronts from the back. The only assembly required is to sew the fronts to the back to create the shoulder seams.

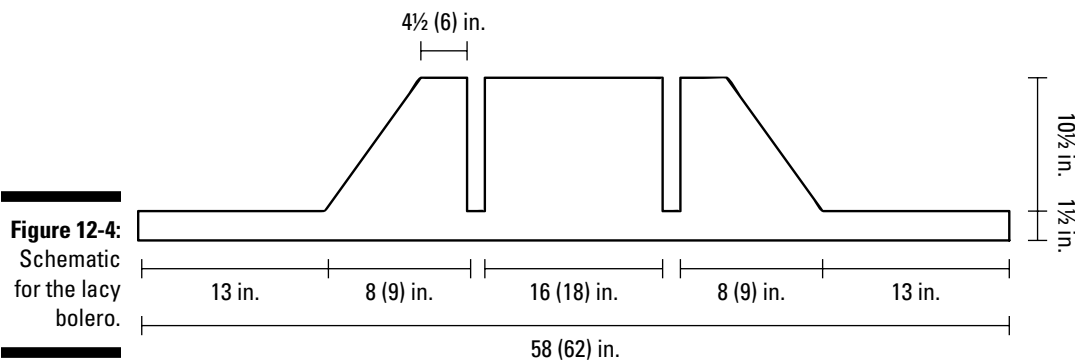

**Figure 12-4:**  
Schematic  
for the lacy  
bolero.

## Laying the foundation

**Foundation chain:** Ch 294 (315) + 3 (first dc) + 1 (first ch-1 space).

**Row 1 (right side):** Dc in 5th ch from hook, • ch 2, skip next 5 ch, 4 dc in next ch, ch 2, dc in next ch •, rep from • to • across to within last 6 ch, ch 2, skip next 5 ch, 4 dc in last ch (41 [44] shells and 2 half shells), *turn*.

**Row 2 (wrong side):** Ch 3 (first dc), ch 1 (first ch-1 space), dc in first dc, • ch 2, shell in ch-2 space of next shell •, rep from • to • across to within last shell, shell in ch-2 space of last shell, ch 2, 4 dc in last ch-1 space (41 [44] shells and 2 half shells), *turn*.

**Row 3:** Rep Row 2 for pat. Fasten off.

## *Beginning with the body*

**Row 4:** With wrong side facing, skip first 10 shells, skip next ch-2 space, join yarn in next dc, ch 3 (first dc), 3 dc in ch-2 space, work in established pat across next 22 (25) shells, skip next 3 dc, (dc, ch 1, dc) in next dc (22 [25] shells and 2 half shells), *turn*, leaving rem sts unworked.

**Row 5:** Ch 1, sc in first ch-1 space (dec made), shell in ch-2 space of next shell, ch 2, work in established pat across to within last 4 dc, skip next 2 dc, sc in next dc (dec made) (22 [25] shells), *turn*.

## *Focusing on the left front*

**Row 1:** Ch 2, skip next ch-2 space, shell in ch-2 space of next shell, work in established pat across next 4 (5) shells, ch 2, skip next 3 dc (dc, ch 1, dc) in next dc (5 [6] shells and 1 half shell), *turn*, leaving rem sts unworked.

**Row 2:** Ch 3 (first dc), ch 1 (first ch-1 space), dc in first ch-1 space, ch 2, work in established pat across next 5 shells, ch 2, skip next 3 dc, sc in last dc (4 [5] shells and 1 half shell), *turn*.

**Row 3:** Ch 2, 4 dc in ch-2 space of next shell, ch 2, work in established pat across next 3 (4) shells, ch 2, skip next 4 dc, (dc, ch 1, dc) in last ch-1 space (3 [4] shells and 2 half shells), *turn*.

**Row 4:** Ch 3 (first dc), ch 1 (first ch-1 space), dc in first ch-1 space, ch 2, work in established pat across next 3 (4) shells, ch 2, skip next 4 dc, skip next ch-2 space, sc in last dc (3 [4] shells), *turn*.

**Row 5:** Ch 2, 4 dc in ch-2 space of next shell, ch 2, work in established pat across next 2 (3) shells, ch 2, skip next 4 dc, (dc, ch 1, dc) in last ch-1 space (2 [3] shells and 2 half shells), *turn*.

**Row 6:** Ch 3 (first dc), ch 1 (first ch-1 space), dc in first ch-1 space, ch 2, work in established pat across next 2 (3) shells, ch 2, skip next 4 dc, skip next ch-2 space, sc in last dc (2 [3] shells and 1 half shell), *turn*.

**Row 7:** Ch 2, 4 dc in ch-2 space of next shell, ch 2, work in established pat across next 1 (2) shells, ch 2, skip next 4 dc, (dc, ch 1, dc) in last ch-1 space (1 [2] shells and 2 half shells), *turn*.

**Row 8:** Ch 3 (first dc), ch 1 (first ch-1 space), dc in first ch-1 space, ch 2, shell in each of next 1 (2) shells, skip next ch-2 space, skip next 3 dc, (dc, ch 1, dc) in last dc (1 [2] shells and 2 half shells), *turn*.

Work even in established pat for 16 rows. Fasten off.

## *Heading around to the back*

**Row 1:** With wrong side facing, skip first shell to the left of last shell made in first row of left front, skip next ch-2 space, join yarn in ch-2 space of next shell, ch 3 (first dc), 3 dc in ch-2 space, work in established pat across next 8 (9) shells, shell in next shell, ch 2, (dc, ch 1, dc) in last dc of current shell (9 [10] shells and 2 half shells), *turn*, leaving rem sts unworked.

Work even in established pat for 23 rows. Fasten off.

## *Turning to the right front*

**Row 1:** With wrong side facing, skip first shell to the left of last shell made in first row of back, skip next ch-2 space, join yarn in next dc, ch 3 (first dc), (ch 1, dc) in next ch-2 space, ch 2, shell in each of next 5 (6) shells, ch 2, skip next half shell, sc in next dc 2 rows below (5 [6] shells), *turn*.

**Row 2:** Ch 2, shell in each of next 4 (5) shells, ch 2, (dc, ch 1, dc) in last ch-1 space (4 [5] shells and 1 half shell), *turn*.

**Row 3:** Ch 3 (first dc), (ch 1, dc) in first ch-1 space, ch 2, work in established pat across next 3 (4) shells, ch 2, 4 dc in next shell (3 [4] shells and 2 half shells), *turn*, leaving rem sts unworked.

**Row 4:** Ch 2, work in established pat across next 3 (4) shells, ch 2, (dc, ch 1, dc) in last ch-1 space (3 [4] shells and 1 half shell), *turn*.

**Row 5:** Ch 3 (first dc), (ch 1, dc) in first ch-1 space, ch 2, work in established pat across next 2 (3) shells, ch 2, 4 dc in next shell (2 [3] shells and 2 half shells), *turn*, leaving rem sts unworked.

**Row 6:** Ch 2, work in established pat across next 2 (3) shells, ch 2, (dc, ch 1, dc) in last ch-1 space (2 [3] shells and 1 half shell), *turn*.

**Row 7:** Ch 3 (first dc), (ch 1, dc) in first ch-1 space, ch 2, work in established pat across next 1 (2) shells, ch 2, 4 dc in next shell (1 [2] shells and 2 half shells), *turn*, leaving rem sts unworked.

**Row 8:** Ch 2, work in established pat across next 1 (2) shells, ch 2, (dc, ch 1, dc) in last ch-1 space (1 [2] shells and 2 half shells), *turn*.

Work even in established pat for 16 rows. Fasten off.

## *Joining the fronts to the back*

With right sides facing, using tapestry needle and yarn, whipstitch fronts to back across shoulders, matching sts from outside edges and working toward neck. Turn right side out.

## *Adding the sleeves*

**Rnd 1:** With right side facing, join yarn in ch-2 space of shell at center of underarm, ch 3 (first dc), 3 dc in ch-2 space, ch 2, dc in same space, ch 2, working in row-end sts around edges of armhole, • skip next 2 row-end sts, shell in next row-end st, ch 2 •, rep from • to • around (16 shells and 1 half shell), ch 2, sl st in first dc to join, *turn*.

**Rnd 2:** Ch 3 (first dc), (ch 1, dc) in sl st, ch 2, work in established pat around (16 shells and 1 half shell), ch 2, sl st in turning ch to join.

**Rnd 3:** Ch 3 (first dc), ch 2 (first ch-2 space), work in established pat around, ch 2, 3 dc in last ch-1 space (16 shells and 1 half shell), sl st in first dc to join, *turn*.

**Rnd 4:** Sl st in each of first 4 dc, ch 2, work in established pat around to within last shell, shell in last shell (16 shells), ch 2, sl st in first sl st to join, *turn*.

Work now progresses in rows.

**Row 5:** Sl st in first ch-2 space, ch 2, work in established pat across to within last 2 shells, shell in next shell, ch 2, sl st in first dc of next shell (15 shells), *turn*, leaving rem sts unworked.

**Row 6:** Ch 2, work in established pat across to within last shell, shell in last shell (15 shells), *turn*.

**Row 7:** Sl st in first ch-2 space, ch 2, work in established pat across next 10 shells, ch 2, 4 dc in next shell (10 shells and 1 half shell), *turn*.

**Row 8:** Ch 2, sl st in next ch-2 space, ch 2, work in established pat across next 8 shells, ch 2, sl st in next ch-2 space (8 shells), *turn*.

**Row 9:** Ch 2, sl st in next ch-2 space, ch 2, work in established pat across next 6 shells, ch 2, sl st in next ch-2 space (6 shells). Fasten off.

Rep sleeve around other armhole.

## *Finishing with easy edgings*

You use single crochet stitches to complete the bolero and give it a polished look.

### *Outside edging*

With right side facing, join yarn in center st on lower edge of center back, ch 1, sc evenly around entire outside edge, working in ch spaces, sts, and row-end sts, sl st in first sc to join. Fasten off.

### *Sleeve edging*

With right side facing, join yarn in center st at underarm, ch 1, sc evenly around entire outside edge of sleeve, working in ch spaces, sts, and row-end sts, sl st in first sc to join. Fasten off. Rep around other sleeve.

## Springtime Pullover

This lightweight, V-neck pullover is great for that layered look that never goes out of style (see Figure 12-5). Made with a light-weight *cotton flake yarn* (that means the yarn has thick and thin spots), the sweater is ideal for days when the weather is just starting to warm up, but isn't quite there yet.



**Figure 12-5:**  
Create a layered look with the springtime pullover.

The stitch pattern is used quite often for garments: single crochet and chain stitches. You work in the chain spaces which makes the work move right along. Beads finish off the bottom edge and sleeves, giving it a special flair. Because you work the sleeves right onto the garment instead of working them separately, and then work some bead crochet, the pattern is suitable when you're ready for an intermediate-level project. I know you'll be just fine and will add new skills to your crochet library in the process.

### Materials and vital statistics

- ✓ **Size:** Directions are for size Small (2–4). Changes for Medium (6–8), Large (10–12), and X-Large (14–16) are in parentheses.
- ✓ **Yarn:** Ironstone Warehouse “Flake Cotton” light-weight cotton flake yarn (100% mercerized cotton), (3.5 oz. [100 g], 328 yds [300 m] each skein): 3 (4, 4, 5) skeins of #8702
- ✓ **Hook:** Crochet hook size H-8 U.S. or size needed to obtain gauge
- ✓ **Tapestry needle**
- ✓ **Approximately 100 8mm clear blue glass or plastic beads**
- ✓ **Measurements:** Finished bust: 30 (34, 38, 42) in. Back length: 20 (20, 21, 21) in. Sleeve length: 9¼ in. Figure 12-6 shows finished measurements.



✓ **Gauge:** 15 sts and 15 rows in pat = 3 in.

✓ **Stitches used:** Chain stitch (ch), slip stitch (sl st), single crochet (sc). **Dec 1 sc:** • (Insert hook in next st, yo, draw yarn through st) twice, yo, draw yarn through 3 loops on hook •.

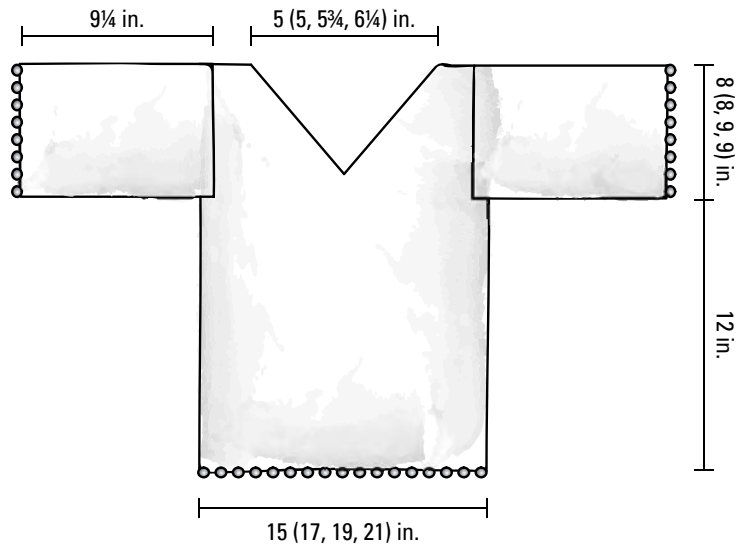

**Figure 12-6:**  
Schematic  
for the  
pullover.

The stitch pattern used to create the fabric for this sweater is really wonderful. It creates a fabric tight enough so you can't see through it, yet is still flexible so you don't end up with a stiff garment. The layered look works perfectly with this design — throw on one of those lacy little tanks to finish off the look. Creating the V-neck shape for both the front and back is accomplished by decreasing your stitches in the designated rows only at the neck edge of the sweater until you reach the correct number of stitches. Then you work even until the length of the sweater is reached.

## *Fashioning the front and back*

**Note:** You need to follow these directions twice — once for the front, once for the back.

**Foundation chain:** Ch 76 (86, 96, 106).

**Row 1:** Sc in 2nd ch from hook, sc in each ch across (75 [85, 95, 105] sc), *turn*.

**Row 2:** Ch 1, sc in first sc, • ch 1, skip next sc, sc in next sc •, rep from • to • across (37 [42, 47, 52] ch-1 spaces), *turn*.

**Row 3:** Ch 1, sc in first sc, • sc in next ch-1 space, ch 1, skip next sc • rep from • to • across to within last ch-1 space, sc in ch-1 space, sc in last sc (36 [41, 46, 51] ch-1 spaces), *turn*.

**Row 4:** Ch 1, sc in first sc, • ch 1, skip next sc, sc in next ch-1 space •, rep from • to • across to within last 2 sc, ch 1, sc in last sc (37 [42, 47, 52] ch-1 spaces), *turn*.

Rep Rows 3–4 for pat. Work even in established pat until piece measures 12 in. from beg, ending with Row 3.

**Shape armholes**

**Next Row:** Sl st in each of next 5 (5, 7, 7) sts, ch 1, work in established pat across to within last 6 (6, 8, 8) sts, sc in next st (32 [37, 42, 47] ch-1 spaces), *turn*, leaving rem sts unworked.

Work even in established pat across these sts for 3 (3, 5, 5) rows.

**Beg first neck**

**Next Row:** Ch 1, work in established pat across first 31 (37, 41, 47) sts (15 [18, 20, 23] ch-1 spaces), *turn*, leaving rem sts unworked.

**Next Row:** Dec 1 sc in first 2 sts, work in established pat across (30 [36, 40, 46] sts), *turn*.

Work even in established pat for 2 rows.

Maintaining established pat, dec 1 sc at neck edge every 3rd row until 20 (25, 28, 32) sts rem on work.

Work even across 20 (25, 28, 32) sts until first neck measures 8 (8, 9, 9) in. from beg of armhole shaping. Fasten off.

**Second neck**

With appropriate side facing, skip one st to the left of last st made in first row of first neck, join yarn in next st, ch 1, work in established pat across (31 [37, 41, 47] sts), *turn*.

**Next Row:** Ch 1, work in established pat across to within last 2 sts, dec 1 sc in last 2 sts (30 [36, 40, 46] sts), *turn*.

Work even in established pat for 2 rows.

Maintaining established pat, dec 1 sc at neck edge every 3rd row until 20 (25, 28, 32) sts rem on work.

Work even across 20 (25, 28, 32) sts until second neck measures 8 (8, 9, 9) in. from beg of armhole shaping. Fasten off.

**Attaching the front and back**

With right sides facing, using tapestry needle and yarn, sew front to back across shoulders using the whipstitch. You'll sew the side seams when the sleeves are complete.

**Checking out what's up with your sleeves**

Don't worry if you end up with more stitches in the sleeve than you worked across the body of the sweater. Sleeves can be deceptive in size and are often wider than the front or back of the sweater itself, though they don't appear so.

**Row 1:** With right side facing, join yarn in first st at beg of armhole shaping, working in row-end sts across armhole, ch 1, sc in first row-end st, • ch 1, skip next st, sc in next st •, rep from • to • across to beg of armhole shaping on opposite side of armhole, ending with an odd number of sts, *turn*.

**Row 2:** Sl st in next st of armhole, ch 1, sc in first st in Row 1 of sleeve, work in established pat across, *turn*.

Rep Row 2 (3 [3, 5, 5] times).

**Next Row:** Ch 1, work even in established pat across, *turn*.

Work even in established pat until sleeve measures 4 in. from beg.

**Next Row:** Dec 1 st in first 2 sts, work in established pat across to within last 2 sts, dec 1 st in last 2 sts, *turn*.

Work even in established pat for 4 more rows, then dec 1 st at each end of next row and every 5th row thereafter 4 more times. Fasten off.

Rep sleeve across other armhole.

## Completing the sweater assembly

With right sides facing, using tapestry needle and yarn, sew side seams and underarm seams using the whipstitch. Leave sweater with wrong side facing out.

## Adding the finishing touches



When crocheting with beads, the bead pops to the opposite side of the fabric that's facing you, so to get the beads to show up on the right side, you have to work from the wrong side.

### Bottom edging

String 45 beads onto yarn. With wrong side facing, join yarn in one side seam, working across opposite side of foundation ch, ch 1, • sc in each of next 3 sts, draw 1 bead up close to hook, sc in next st •, rep from • to • evenly around bottom edge, sl st in first sc to join. Fasten off.

### Sleeve edging

String 25 beads onto yarn. With wrong side facing, join yarn in underarm seam, ch 1, • sc in each of next 3 sts, draw 1 bead up close to hook, sc in next st •, rep from • to • evenly around lower edge of sleeve, sl st in first sc to join. Fasten off.

Rep sleeve edging across lower edge of other sleeve.

### Neck edging

Turn sweater right side out. With right side facing, join yarn in one shoulder seam, ch 1, • sc in next st, ch 1, skip next st •, rep from • to • evenly around entire neck edge, sl st in first sc to join. Fasten off.

## Shell Stitch Tank Top

When warmer weather comes around, many of us put down our crochet hooks thinking that it's too hot to work with yarn. But with this pretty tank top, you can continue crocheting without having a lot of bulky yarn on your lap. Even better, you'll have a comfortable, cool, and fashionable top that you can pair with jeans, shorts, or a skirt (see Figure 12-7).



**Figure 12-7:**

This easy tank top is light enough to stitch—and wear—during the hot summer months.

This design features the very versatile shell stitch, made with five double crochet stitches. As with many stitch patterns, variations on both the stitch itself and the pattern exist, but this pattern produces a fabric with stitches that are tight enough that you don't have to worry about anything underneath peeking through.

## Materials and vital statistics

- ✓ **Size:** Directions are for size X-Small (4). Changes for Small (6), Medium (8–10), Large (12–14), and X-Large (16) are in parentheses.
- ✓ **Yarn:** Artful Yarns “Fable” worsted-weight yarn (85% pima cotton/15% silk), (3.5 oz. [100 g], 184 yds [168 m] each hank): 4 (4, 5, 5, 5) hanks of #93 Little Red Riding Hood
- ✓ **Hook:** Crochet hook size G-6 U.S. or size needed to obtain gauge
- ✓ **Tapestry needle**
- ✓ **Measurements:** Finished bust: 25½ (28, 30½, 32½, 35) in. Back length: 20½ (20½, 20½, 21¼, 21¼) in. Figure 12-8 shows finished measurements.
- ✓ **Gauge:** 3 shells in pat = 3½ in.; 7 rows in pat = 3 in.
- ✓ **Stitches used:** Chain stitch (ch), slip stitch (sl st), single crochet (sc), double crochet (dc). **Shell:** • 5 dc in same stitch •.

This design will definitely give you some practice with the shell stitch. The pattern here calls for a 5-double crochet shell, which is pretty common. You'll see how to adjust the pattern so that the shells nestle upon each other in subsequent rows. There's very little neck shaping and no sleeves, so you can complete this project in no time.

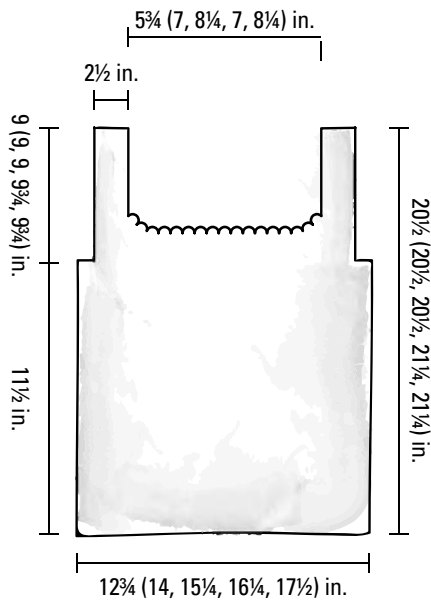

**Figure 12-8:**  
Schematic  
for the  
tank top.

## First, you've got your back

**Foundation chain:** Ch 68 (74, 80, 86, 92).

**Row 1 (right side):** Sc in 2nd ch from hook, • skip next 2 ch, shell in next ch, skip next 2 ch, sc in next ch •, rep from • to • across (11 [12, 13, 14, 15] shells), *turn*.

**Row 2 (wrong side):** Ch 3 (first dc), 2 dc in first sc (half shell made), sc in center dc of next shell, • shell in next sc, sc in center dc of next shell •, rep from • to • across to within last sc, 3 dc in last sc (10 [11, 12, 13, 14] shells and 2 half shells), *turn*.

**Row 3:** Ch 1, sc in first dc, skip next 2 dc, • shell in next sc, sc in center dc of next shell •, rep from • to • across to within last sc, shell in next sc, skip next 2 dc, sc in last dc (11 [12, 13, 14, 15] shells), *turn*.

Rep Rows 2–3 for pat until back measures 11½ in. from beginning, ending with Row 2 of pat.

### Shape armholes

**Next Row (right side):** Sl st to center dc of first (first, first, second, second) shell, ch 1, sc in dc, work in established pat across to within last 1 (1, 1, 2, 2) shell(s), sc in center dc of shell (9 [10, 11, 10, 11] shells), *turn*, leaving rem sts unworked.

Work even in established pat for 13 (13, 13, 15, 15) more rows.

### Shape right neck

**Next Row (right side):** Ch 1, sc in first dc, • shell in next sc, sc in center dc of next shell •, rep from • to • twice (3 shells), *turn*, leaving rem sts unworked.

**Next Row:** Sl st to center dc of first shell, ch 1, sc in dc, shell in next sc, work in established pat across to last sc, 3 dc in last sc (2 shells and 1 half shell), *turn*.

**Next Row:** Ch 1, sc in first dc, • shell in next sc, sc in center dc of next shell •, rep from • to • once (2 shells), *turn*, leaving rem sts unworked.

Work even in established pat for 4 more rows. Fasten off.

**Shape left neck**

**Next Row:** With right side facing, skip center 2 (3, 4, 3, 4) shells, skip next sc, join yarn in center dc of next shell, ch 1, sc in dc, work in established pat across (3 shells), *turn*.

**Next Row:** Ch 3 (first dc), 2 dc in first sc, work in established pat across to within last shell, sc in center dc of last shell (2 shells and 1 half shell), *turn*, leaving rem sts unworked.

**Next Row:** Sl st to center dc of first shell, ch 1, sc in dc, work in established pat across (2 shells), *turn*.

Work even in established pat for 4 more rows. Fasten off.

**Next, focus on the front**

**Foundation chain:** Ch 68 (74, 80, 86, 92).

**Row 1 (right side):** Sc in 2nd ch from hook, • skip next 2 ch, shell in next ch, skip next 2 ch, sc in next ch •, rep from • to • across (11 [12, 13, 14, 15] shells), *turn*.

**Row 2 (wrong side):** Ch 3 (first dc), 2 dc in first sc (half shell made), sc in center dc of next shell, • shell in next sc, sc in center dc of next shell •, rep from • to • across to within last sc, 3 dc in last sc (10 [11, 12, 13, 14] shells and 2 half shells), *turn*.

**Row 3:** Ch 1, sc in first dc, skip next 2 dc, • shell in next sc, sc in center dc of next shell •, rep from • to • across to last sc, shell in next sc, skip next 2 dc, sc in last dc (11 [12, 13, 14, 15] shells), *turn*.

Rep Rows 2–3 for pat until front measures 11½ in. from beginning, ending with Row 2 of pat.

**Shape armholes**

**Next Row (right side):** Sl st to center dc of 1st (1st, 1st, 2nd, 2nd) shell, ch 1, sc in dc, work in established pat across to within last 1 (1, 1, 2, 2) shell(s), sc in center dc of shell (9 [10, 11, 10, 11] shells), *turn*, leaving rem sts unworked.

Work even in established pat for 3 more rows.

**Shape left neck**

**Next Row (right side):** Ch 1, sc in first dc, • shell in next sc, sc in center dc of next shell •, rep from • to • twice (3 shells), *turn*, leaving rem sts unworked.

**Next Row:** Sl st to center dc of first shell, ch 1, sc in dc, shell in next sc, work in established pat across to within last sc, 3 dc in last sc (2 shells and 1 half shell), *turn*.

**Next Row:** Ch 1, sc in first dc, • shell in next sc, sc in center dc of next shell •, rep from • to • once (2 shells), *turn*, leaving rem sts unworked.

Work even in established pat for 14 (14, 14, 16, 16) more rows. Fasten off.

**Shape right neck**

**Next Row:** With right side facing, skip center 2 (3, 4, 3, 4) shells, skip next sc, join yarn in center dc of next shell, ch 1, sc in dc, work in established pat across (3 shells), *turn*.

**Next Row:** Ch 3 (first dc), 2 dc in first sc, work in established pat across to within last shell, sc in center dc of last shell (2 shells and 1 half shell), *turn*, leaving rem sts unworked.

**Next Row:** Sl st to center dc of first shell, ch 1, sc in dc, work in established pat across (2 shells), *turn*.

Work even in established pat for 14 (14, 14, 16, 16) more rows. Fasten off.

### *In the home stretch! Tackling the assembly*

With right sides facing, using tapestry needle and yarn, sew front to back across shoulders, using the whipstitch. Beginning at lower edge of each side, matching stitches across side edges, sew side seams from lower edge to armholes.

### *Finally, finishing with armhole edging*

With right side facing, join yarn in side seam at lower edge of one armhole, ch 1, sc evenly around entire armhole, sl st in first sc to join. Fasten off.

Repeat armhole edging around other armhole.

## *Fur-Trimmed Jacket*

If you're looking for something with a bit of class, you've come to the right place. The design of this jacket is slightly fitted, sits on the hip, and is trimmed with a "fur" collar and cuffs. The striped pattern is easy to work (see Figure 12-9). Carry the yarn up the sides and you won't have to worry about weaving in a zillion little ends (see Chapter 4 for details on carrying the yarn).



**Figure 12-9:**  
You'll look striking wearing this fitted jacket with faux fur.

## Materials and vital statistics

- ✓ **Size:** Directions given are for size X-Small (2–4). Changes for Small (6–8), Medium (10–12), and Large (14–16) are in parentheses.
- ✓ **Yarn:**
  - Patons “Classic Wool” worsted-weight yarn (100% pure new wool), Article #244077 (3.5 oz. [100 g], 223 yds [204 m] each skein): 3 (3, 3, 4) skeins of #0231 Chestnut Brown (A)
  - Patons “Divine” bulky-weight yarn (76.5% acrylic/10.5% mohair/10.5% wool/2.5% polyester), Article #241006 (3.5 oz. [100 g], 142 yds [130 m] each skein): 3 (3, 3, 4) skeins of #06013 Deep Earth (B)
  - Patons “Allure” bulky-weight yarn (100% nylon), Article #241004 (1.75 oz. [50 g], 47 yds [43 m] each skein): 2 skeins of #04040 Ebony (C)
- ✓ **Hook:** Crochet hook size J-10 U.S. or size needed to obtain gauge
- ✓ **Yarn needle**
- ✓ **6 buttons, 1 in. in diameter**
- ✓ **Sewing needle and matching sewing thread**
- ✓ **Measurements:** Finished bust: 32 (36, 40, 44) in. Back length: 20 (21, 22, 23) in. Sleeve length: 17 (17, 17, 17½) in., excluding cuff. Figure 12-10 shows finished measurements.
- ✓ **Gauge:** 12 sts and 12 rows in pat = 4 in.
- ✓ **Stitches used:** Chain stitch (ch), slip stitch (sl st), single crochet (sc), half double crochet (hdc)

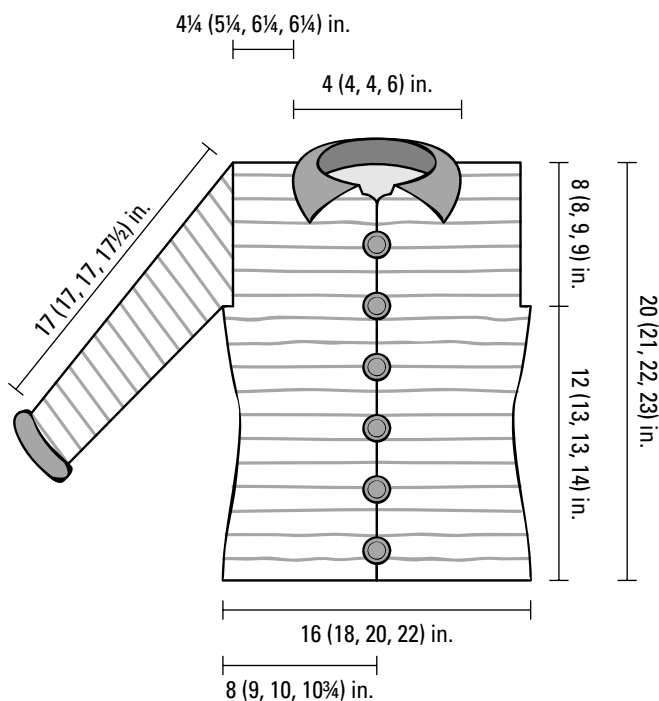

**Figure 12-10:** Schematic for the fur-trimmed jacket.



The construction of this jacket is pretty typical of garments in general. Each piece is made separately and then sewn together. You start with the back, then make each of the fronts. When these pieces are finished, you sew them together, and your project starts to look like something. Then you crochet each of the sleeves and sew them into place. Last but not least, you add the fur collar and cuffs to complete the design.

## *Getting down to business: The back*

**Foundation chain:** With A, ch 47 (53, 59, 65) + 2 (first hdc).

**Row 1 (right side):** Hdc in 3rd ch from hook, hdc in each ch across (48 [54, 60, 66] hdc), *turn*.

**Row 2:** Ch 2 (first hdc), hdc in each hdc across (48 [54, 60, 66] hdc), *turn*. Drop A, join B.

**Row 3:** With B, ch 1, sc in each hdc across (48 [54, 60, 66] sc), *turn*.

**Row 4:** Ch 1, sc in each sc across (48 [54, 60, 66] sc), *turn*. Drop B, pick up A.

**Row 5:** With A, ch 2 (first hdc), hdc in each sc across (48 [54, 60, 66] hdc), *turn*.

**Row 6:** Ch 2 (first hdc), hdc in each hdc across (48 [54, 60, 66] hdc), *turn*. Drop A, pick up B.

Rep Rows 3–6 for pat. Work even in pat until back measures 4 in. from beg.

Maintaining established pat, dec 1 st at each end of next row and every row thereafter for 3 more rows (40 [46, 52, 58] sts at end of last row).

Work even in established pat for 4 rows.

Maintaining established pat, inc 1 st at each end of next row and every row thereafter for 3 more rows (48 [54, 60, 66] sts at end of last row).

Work even in established pat until back measures 12 (13, 13, 14) in. from beg.

### *Shape armholes*

**Next Row:** Maintaining established pat, sl st in each of first 5 sts, work in pat across to within last 5 sts, *turn*, leaving rem sts unworked (38 [44, 50, 56] sts).

Work even in established pat until back measures 8 (8, 9, 9) in. from beg of armhole shaping. Fasten off.

## *What's left? The left front*

**Foundation chain:** With A, ch 23 (26, 29, 31) + 2 (first hdc).

**Row 1 (right side):** Hdc in 3rd ch from hook, hdc in each ch across (24 [27, 30, 32] hdc), *turn*.

**Row 2:** Ch 2 (first hdc), hdc in each hdc across (24 [27, 30, 32] hdc), *turn*. Drop A, join B.

Work even in pat as established in back until left front measures 4 in. from beg, ending with a wrong-side row.

**Next Row (right side):** Dec 1 st in first 2 sts, work in established pat across (23 [26, 29, 31] sts), *turn*.

**Next Row:** Work in established pat across to within last 2 sts, dec 1 st in last 2 sts (22 [25, 28, 30] sts), *turn*.

Rep last 2 rows once (20 [23, 26, 28] sts at end of last row), *turn*.

Work even in established pat for 4 rows.

Maintaining established pat, inc 1 st at outside edge on next row and every row thereafter for 3 more rows (24 [27, 30, 32] sts at end of last row), *turn*.

Work even in established pat until left front measures 12 (13, 13, 14) in. from beg.

### ***Shape armhole***

**Next Row:** Maintaining established pat, sl st in each of first 5 sts, work in pat across (19 [22, 25, 27] sts), *turn*.

Work even in established pat until left front measures 5 rows less than finished back, ending with a wrong-side row.

### ***Shape neck***

**Next Row (right side):** Work in established pat across first 17 (20, 23, 23) sts, *turn*, leaving rem sts unworked.

Maintaining established pat, dec 1 st at neck edge on next row and every row thereafter for 3 more rows (13 [16, 19, 19] sts at end of last row). Fasten off.

## ***It's all right: The right front***

Work same as left front until right front measures 4 in. from beg, ending with a wrong-side row.

**Next Row (right side):** Work in established pat across to within last 2 sts, dec 1 st in last 2 sts (23 [26, 29, 31] sts), *turn*.

**Next Row:** Dec 1 st in first 2 sts, work in established pat across (22 [25, 28, 30] sts), *turn*.

Rep last 2 rows once (20 [23, 26, 28] sts at end of last row), *turn*.

Work even in established pat for 4 rows.

Maintaining established pat, inc 1 st at outside edge on next row and every row thereafter for 3 more rows (24 [27, 30, 32] sts at end of last row), *turn*.

Work even in established pat until right front measures 12 (13, 13, 14) in. from beg.

***Shape armhole***

**Next Row:** Work in established pat across first 19 (22, 25, 27) sts, *turn*, leaving rem sts unworked.

Work even in established pat until right front measures 5 rows less than finished back, ending with a wrong side row.

***Shape neck***

**Next Row (right side):** Sl st in each of first 2 (2, 2, 4) sts, work in established pat across 17 (20, 23, 23) sts, *turn*.

Dec 1 st at neck edge on next row and every row thereafter for 3 more rows (13 [16, 19, 19] sts at end of last row). Fasten off.

***Fronts meet back: Attaching the pieces***

With right sides facing, using yarn needle and A, sew fronts to back across shoulders using the whipstitch.

***Armed and delicate: Creating the sleeves***

**Note:** You need to make two of these.

**Foundation chain:** With A, ch 51 (51, 51, 54) + 2 (first hdc).

**Row 1 (right side):** Hdc in 3rd ch from hook, hdc in each ch across (52 [52, 52, 55] hdc), *turn*.

**Row 2:** Ch 2 (first hdc), hdc in each hdc across (52 [52, 52, 55] hdc), *turn*. Drop A, join B.

Work even in pat as established in back body of sweater until sleeve measures 3 in. from beg.

Maintaining established pat, dec 1 st at each end of next row and every 4th row thereafter until 32 (32, 32, 35) sts rem on work.

Work even in established pat until sleeve measures 17 (17, 17, 17½) in. from beg. Fasten off.

***Sew what? Joining the sleeves to the jacket body***

With right sides facing, using yarn needle and A, sew sleeves into armholes using the whipstitch. Sew side and underarm seams.



When sewing the side and underarm seams, make sure to match the stripes. That way your sweater's appearance will be "seamless"!

## *Delightful! Finishing with details*

Many times, the details draw you to a piece of clothing. You can't resist the feel of the fabric or the fancy buttons or the collar. Here's where you create the details that will really make people notice your work of art.

### *Button band*

**Row 1:** With right side facing, join A in first st at top edge of left front. Working in row-end sts across center front edge, sc evenly across to last st at bottom edge, *turn*.

**Rows 2–3:** Ch 1, sc in each sc across, *turn*. Fasten off.

### *Buttonhole Band*

**Row 1:** With right side facing, join A in first st at bottom edge of right front, ch 1, working in row-end sts across center front edge, sc evenly across to beg of neck shaping, *turn*. Mark spaces for buttonholes with top buttonhole 1 in. below top edge, bottom buttonhole 1 in. above bottom edge, and rem 4 buttonholes evenly spaced between.

**Row 2:** Ch 1, sc in each sc across, working (ch 3, skip next 3 sc) at each marker, *turn*.

**Row 3:** Ch 1, sc in each sc across, working 3 sc in each ch-3 loop. Fasten off.

With sewing needle and matching thread, sew buttons to button band opposite buttonholes.

### *Collar*

**Row 1:** With right side facing, join C in first st at beg of neck shaping, ch 1, sc evenly across neck edge to last st of neck shaping on opposite side, *turn*.

**Rows 2–7:** Ch 1, 2 sc in first sc, sc in each sc across to within last sc, 2 sc in last sc, *turn*. Fasten off.

### *Cuff*

**Rnd 1:** With right side facing, join C in underarm seam at cuff edge of one sleeve, ch 1, sc evenly around cuff edge, sl st in first sc to join.

**Rnds 2–5:** Ch 1, sc in each sc around, sl st in first sc to join. Fasten off.

Rep cuff around lower edge of other sleeve.

## Chapter 13

# Timeless Techniques: Using the Afghan Stitch and Filet Crochet

---

### *In This Chapter*

- ▶ Creating an adorable baby blanket in basic afghan stitch
  - ▶ Making a tote bag using the Tunisian knit stitch
  - ▶ Showing your love of reading with a filet crochet bookmark
  - ▶ Dressing up your windows with a lacy valance
- 

**T**he two techniques outlined in this chapter are quite different than those shown in other chapters. They aren't any more difficult, they just enable you to create designs with a look that is set apart from traditional crochet. The *afghan stitch*, worked with a special afghan hook, creates a pattern similar to knitting; *filet crochet* uses blocks and spaces to give you a lacy look. It's also perfect for "writing out" words and creating pictures, as you discover in the bookmark project.

Don't be intimidated by something new — I think you'll find these techniques a welcome addition to your crochet skills. Pick a project, grab a hook and some yarn, and start creating!

## *Afghan Stitch Baby Blanket*

Baby items are among the most popular designs to crochet. While I was waiting, rather impatiently, for the arrival of my daughter, I would crochet for her in my spare time. Not only did I create beautiful blankets, booties, and other cute accessories, but keeping my hands busy also helped take my mind off the fact that I couldn't see my feet anymore. Whether for you, a family member, or a friend, crocheted baby items are not only useful, but they also quite often become heirlooms to be passed down through generations.

The afghan stitch lends itself wonderfully to baby blankets because of the tight stitch pattern. It creates a warm fabric without any loose holes for tiny fingers and toes to get caught in. The size of this blanket (see Figure 13-1) was designed with a bassinet or stroller in mind, so it's large enough to cover a baby without the risk of getting tangled up.

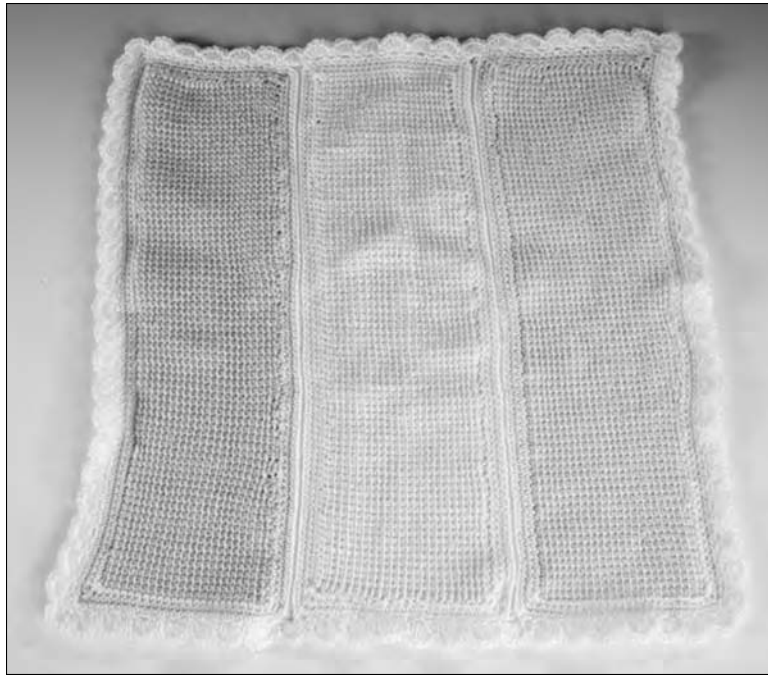

**Figure 13-1:**  
This baby blanket, worked in basic afghan stitch, keeps a little one warm and snugly.

## *New skill: The afghan stitch*

The afghan stitch differs from other crochet stitches in the way you create each stitch. Instead of working off all loops and ending up with just one loop on your hook after each stitch, here the stitches are created across two rows. In the first row, you draw up loops for each stitch, and they all stay on your hook (you have a special hook with an end similar to that of a knitting needle). On the second pass through, you work the loops off the hook. The added benefit to this method is that you don't have to turn your work.

### *Working the first half of the foundation row*

Chain the required number of chain stitches just like you would for any other pattern. Then:

1. Insert your hook in the second chain from the hook, yarn over, and draw the yarn through the stitch (see Figure 13-2a).
2. Insert your hook in the next chain, yarn over, and draw the yarn through the stitch.

You should now have 3 loops on your hook.

3. Repeat Step 2 across the chain, as shown in Figure 13-2b.

This action of adding the loops to your hook is known as *drawing up the loops*. You should have one loop for each chain stitch.

**Figure 13-2:**  
Working the first half of your foundation row.

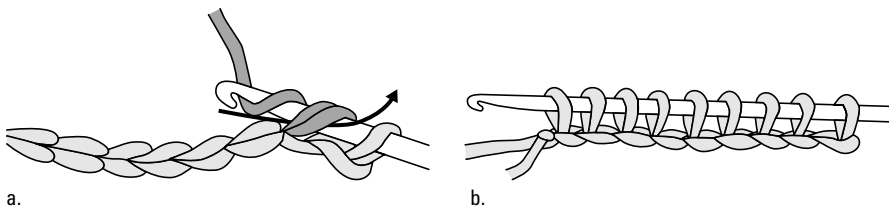

*Working the second half of the foundation row*

When you work the second half of the foundation row, you work the loops off the hook:

1. Yarn over hook, draw the yarn through 1 loop on the hook (see Figure 13-3a).
2. Yarn over hook, draw the yarn through the next 2 loops on your hook (see Figure 13-3b).

**Figure 13-3:**  
Foundation  
row, part  
two:  
Working off  
the loops.

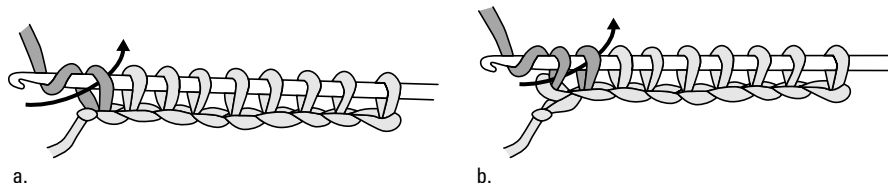

3. Repeat Step 2 across the row until 1 loop remains on your hook (see Figure 13-4).

**Figure 13-4:**  
The finished  
foundation  
row.

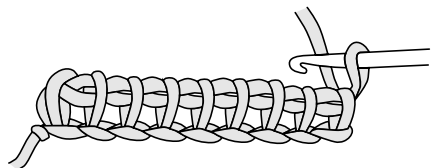
*Working the next row and beyond*

To begin the second row:

1. Insert your hook in the next vertical bar in the row below.  
Don't use the vertical bar directly beneath your hook.
2. Yarn over and draw the yarn through the stitch (see Figure 13-5a).
3. Repeat Steps 1 and 2 across the row until you reach the last stitch.
4. Insert your hook under the last two vertical bars at the end of the row (refer to Figure 13-5b), yarn over, and draw the yarn through both vertical bars.

**Figure 13-5:**  
Working the  
first half  
of the  
second row.

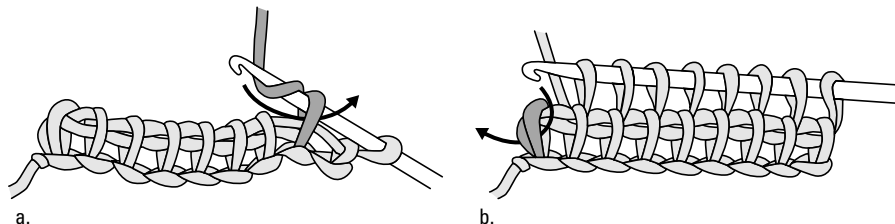

To finish the second row, repeat Steps 1 through 3 from “Working the second half of the foundation row.” Each successive row will be worked in the same way as the second row.



As the saying goes, practice makes perfect. Be sure to work a gauge swatch so you can get the hang of the stitch and make sure your gauge is accurate. Swatches should be about 4 inches square, so if you're using the yarn for this project, start with a foundation chain of 17 stitches, and work 16 rows to make a square. You'll know you've got it right if the vertical bars line up one on top of another.

## Materials and vital statistics

- ✓ **Yarn:** Caron “Simply Soft” 4-ply worsted-weight yarn (100% acrylic), Article #H3000 (3 oz. [85 g], 165 yds [151 m] each skein): 1 skein each of
  - #2615 Soft Blue (A)
  - #2613 Soft Yellow (B)
  - #2705 Soft Green (C)
  - #2601 White (D)
- ✓ **Hooks:**
  - Afghan crochet hook size J-10 U.S. or size needed to obtain gauge
  - Standard crochet hook size J-10 U.S. or size needed to obtain gauge
- ✓ **Measurements:** Panel = 5¾ in. wide x 19½ in. long; blanket = 22½ in. wide x 22½ in. long
- ✓ **Gauge:** Working in basic afghan stitch with afghan crochet hook, 17 sts and 16 rows = 4 in.
- ✓ **Stitches used:** Chain stitch (ch), slip stitch (sl st), single crochet (sc), double crochet (dc), basic afghan stitch (see the “New skill: The afghan stitch” section).  
**Shell:** • 5 dc in same st •.

No one will realize how easy it is to make this design when you show them the finished product. The afghan consists of three separate panels worked in the basic afghan stitch with no increasing or decreasing necessary. After the panels are complete, you crochet a simple edging consisting of single crochet stitches, then join those together with slip stitches. This is a perfect example of how the joining seam becomes part of the design. Add a pretty border with the shell stitch, and you're done.

## Creating a couple of panels

This afghan is made up of 3 panels, one each in colors A, B, and C.

**Foundation row:** With afghan hook and first color, ch 25. Insert hook in second ch from hook, yo, draw yarn through st, • insert hook in next st, yo, draw yarn through st •, rep from • to • across, keeping all loops on hook (25 loops — first half of foundation row complete), beg 2nd half of row, yo, draw yarn through 1 loop on hook, •• yo, draw yarn through 2 loops on hook ••, rep from •• to •• across (1 loop remains and counts as first st of next row).

**Second and successive rows:** Work in basic afghan stitch across all 25 stitches until panel measures 19½ in.

**Last row:** Sl st in each vertical stitch across. Fasten off.



***Panel border***

Work border around each panel.

**Rnd 1:** With right side facing, using standard crochet hook, join D in any corner st, ch 1, sc in each st and row-end st around panel, working 3 sc in each corner st, sl st in first sc to join. Fasten off D, join color to match panel.

**Rnd 2:** Ch 1, sc in each sc around, working 3 sc in each corner st. Fasten off, join D.

**Rnd 3:** With D, rep Rnd 2. Fasten off.

***Putting the panels together and adding the final touch***

With right sides facing, matching stitches across long edges of each panel, using standard crochet hook and D, sl st panels tog through back loops of sts in the foll color sequence: A, B, C to form a square.

***Edging***

**Rnd 1:** With right side facing, using standard crochet hook, join D in any corner st, ch 1, sc in corner st, • ch 1, skip next sc, sc in next sc •, rep from • to • around, working (sc, ch 1, sc) in each corner st, to within last corner st, (sc, ch 1) in corner st, sl st in first sc to join.

**Rnd 2:** Ch 1, sc in first ch-1 space, skip next sc, ••• shell in next ch-1 space, skip next sc, sc in next ch-1 space, skip next sc •, rep from • to • across to next corner, shell in corner ch-1 space ••, rep from •• to •• around, sl st in first sc to join. Fasten off.

***Variation: Making a bigger blankie***

If you want to make this afghan for a toddler, increase the size of each panel by making a longer foundation chain. For instance, to make it twice the size, double the number of stitches in the foundation chain, then keep working rows until the panel reaches the desired length. Follow the directions for the edging and border as written above. Don't forget to buy extra yarn.

***Variation: Picking a new color palette***

This afghan would look really great worked in different colors. Make it solid pink for a little girl or blue for a little boy. Primary colors would look great as well.

***Tunisian Stitch Tote Bag***

What woman will ever say she has enough, or too many, bags? For some reason, most of us seem to carry all kinds of stuff around, not including those items we carry in our purses. This bag will serve a multitude of purposes — it's neither too large nor too small. The colorations in the yarn cause it to resemble a denim tweed when it's worked up, and the Tunisian stitch used (which is a variation of the basic afghan stitch) closely resembles knitting (see Figure 13-6). You get a nice tight fabric with an interesting pattern, and best of all, this yarn is user friendly. When the bag gets dirty, you can throw it in the washer and dryer.



**Figure 13-6:**  
The variation of the afghan stitch and the medium-weight yarn make this a sturdy bag.

## *New skill: The Tunisian knit stitch*

The Tunisian knit stitch, or stockinette stitch as it's sometimes called, is a variation of the basic afghan stitch. The foundation row is worked exactly the same. You'll see the pattern variation when you get to the second row and beyond. Instead of vertical bars appearing as you work, you'll see V's marching across the row, one stacked upon another. The difference comes in the placement of the hook when you draw up your loops. Instead of inserting it under the front vertical bar, you insert it from front to back between the front and back vertical bars.

To start the Tunisian stitch, work a foundation row just as you would for the basic afghan stitch (see the "New skill: The afghan stitch" section in the preceding baby blanket project).

For the first row of Tunisian knit stitch:

1. Insert your hook, from front to back, between the front and back strands of the next vertical stitch, yarn over, and draw the yarn through the stitch (see Figure 13-7a).
2. Repeat Step 1 across the row until you reach the last stitch.
3. Insert your hook under the last 2 vertical bars at the end of the row (see Figure 13-7b), yarn over, and draw the yarn through the stitch.

**Figure 13-7:**  
Working the first half of the Tunisian knit stitch row.

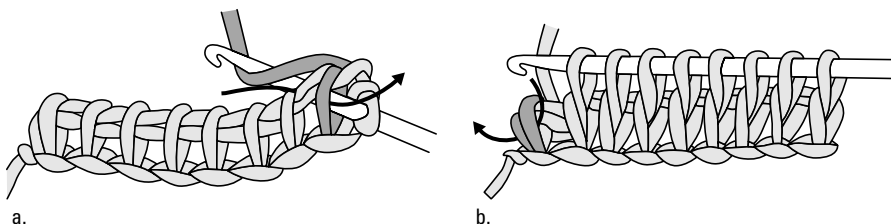

Work the loops off the hook in the same way as described for the basic Afghan stitch in the “New skill: The Afghan stitch” section in the baby blanket project. Now you’ve completed one row of Tunisian knit stitch (see Figure 13-8).

**Figure 13-8:**  
A finished  
first row of  
Tunisian knit  
stitch.

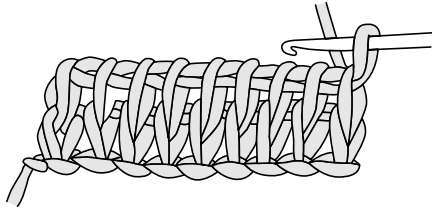

Work a practice swatch using the yarn suggested in this pattern not only to ensure that your gauge is correct, but to get a handle on the stitch. Your swatch should be about 4 inches square, so start with a foundation chain of 15 stitches, then work the Tunisian stitch for 16 rows. The resulting pattern will remind you of a knitted fabric, with a whole bunch of V’s lined up side by side, one on top of another.

## Materials and vital statistics

- ✓ **Yarn:** Coats & Clark Red Heart “Fiesta” worsted-weight yarn (73% acrylic/27% nylon), Article #E704 (6 oz. [170 g], 316 yds [289 m] each skein): 2 skeins of #6382 Country Blue
- ✓ **Hooks:**
  - Afghan hook size J-10 U.S. or size needed to obtain gauge
  - Standard crochet hook size J-10 U.S. or size needed to obtain gauge
- ✓ **Yarn needle**
- ✓ **Measurements:** 13 in. wide x 11½ in. deep, excluding handles
- ✓ **Gauge:** Working in Tunisian knit stitch, 15 sts and 16 rows = 4 in.
- ✓ **Stitches used:** Chain stitch (ch), slip stitch (sl st), single crochet (sc), Tunisian knit stitch (see the “New skill: Tunisian knit stitch” section for how-to’s)

The construction of this bag couldn’t be easier. You crochet a big rectangle using the Tunisian stitch, fold it in half to form the bag, and then sew the side edges together. The handles are added afterward by crocheting several rows of single crochet stitches.

## Making the body of the bag

**Foundation row:** With afghan hook and first color, ch 50. Insert hook in second ch from hook, yo, draw yarn through st, • insert hook in next st, yo, draw yarn through st •, rep from • to • across, keeping all loops on hook (50 loops — first half of foundation row complete), beg 2nd half of row, yo, draw yarn through 1 loop on hook, •• yo, draw yarn through 2 loops on hook ••, rep from •• to •• across (1 loop remains and counts as first st of next row).

**Second and successive rows:** Work in Tunisian knit stitch across all 50 stitches until panel measures 22 in.

**Last row:** Sl st in each vertical stitch across. Fasten off.

### *Assembly*

With right sides facing, fold piece in half crosswise, matching short edges. Using yarn needle and yarn, sew sides of bag together using a whipstitch (see Appendix A for specifics of this stitch), matching stitches. Turn bag right side out.

### *Top edging*

**Rnd 1:** With right side facing, using standard crochet hook, join yarn in one side seam, ch 1, sc in each st around, sl st in first sc to join.

**Rnd 2:** Ch 1, sc in each sc around, sl st in first sc to join. Fasten off.

## *Adding the handles*

**Row 1:** With right side facing, using standard crochet hook, join yarn in st approx 2 in. in from side seam, ch 75, and without twisting ch, sl st in corresponding st approx 2 in. in from other side seam on same edge of bag, sl st in next st on edge of bag, *turn*.

**Row 2:** Ch 1, sc in each ch across, sl st in next sc on edge of bag, *turn*.

**Rows 3–4:** Ch 1, sc in each sc across, sl st in next sc on edge of bag, *turn*. Fasten off.

Rep handle on opposite side of bag.

## *Love-to-Read Bookmark*

This design is for the readers in your life. Anyone who spends a lot of time with books knows how valuable a good bookmark is. The pattern uses the filet crochet stitches of blocks and spaces to spell out a special message (see Figure 13-9), with some basic decreasing at the top.



You'll work from a chart to create this project. Make a copy of the chart and work from that. You can then mark the rows you've completed or highlight the current row, and you'll still have the original for future use. To make the chart even easier to read, enlarge it so you can see where you are and where you're going without having to search for the right row.

## *New skill: Basic filet crochet stitches*

Not only is filet crochet easy to work, but it's easy to read as well. Because filet patterns are charted, you don't have to worry about reading rows and rows of written instructions. The reason they are charted is this: Each square on the chart represents either a *space* or a *block*. Each space or block is made up of a certain number of stitches, which are given to you in a key. Typically, each square is 3 stitches, although as with anything, there are variations. The rows on the chart are numbered, and you work from the bottom up.

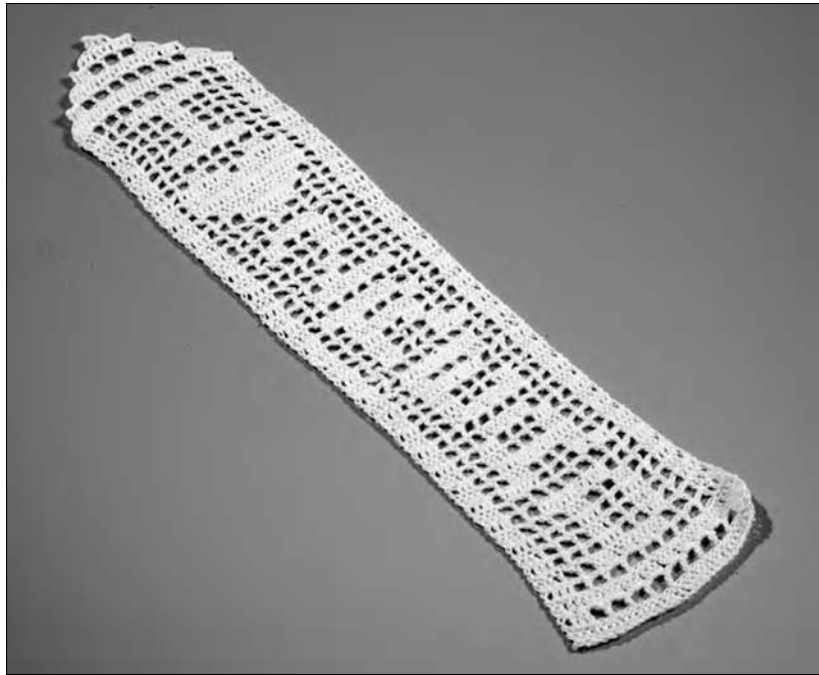

**Figure 13-9:**  
You may think this bookmark is too clever to hide inside a book.

### *Making spaces*

Spaces form the *mesh*, or background, upon which the design is created. They are also used within the design itself to separate the blocks, allowing the picture or words to appear. To work the first row of spaces, chain the designated number of stitches for your foundation chain. Then:

1. **Chain 2 (top of first space), and then double crochet in the 8th chain from the hook to create the first space.**
2. **Chain 2, skip the next 2 chain stitches, and double crochet in the next chain stitch.**

You've just completed the second space.

3. **Repeat Step 2 across the row (see Figure 13-10).**

**Figure 13-10:**  
Working the first row of spaces.

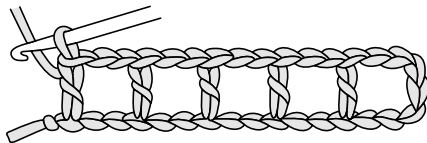

To work the second row of spaces:

1. **Chain 3 for the first double crochet.**
2. **Chain 2 more for the top of the first space.**
3. **Skip the next 2 chain stitches, and double crochet in the next double crochet.**
4. **Repeat Steps 2 and 3 across the row.**

**Building blocks**

Blocks are the solid squares that are used to create the main design, whether it's a picture or a saying. They're also used quite frequently to make a border that frames the main design. To work the first row of blocks, chain the designated number of stitches for your foundation chain, and then:

1. Double crochet in the 4th chain from the hook.
2. Double crochet in the next 2 chain stitches to complete the first block.
3. Double crochet in each of next 3 chain stitches to complete the second block.
4. Repeat Step 3 across the row (See Figure 13-11).

**Figure 13-11:**  
First row of  
filet crochet  
blocks.

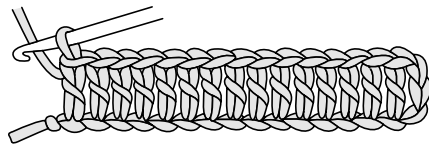

**Practicing with a swatch**

Figure 13-12 shows a chart that you can use to make a swatch and practice filet crochet spaces and blocks. To make a swatch that is 5 squares wide by 5 rows high and uses both spaces and blocks, follow these steps:

1. Chain 18 for your foundation chain.
2. Chain 2 to create the top of the first space.
3. Double crochet in the 8th chain from the hook to create the first space.
4. Chain 2.
5. Skip the next 2 chain stitches.
6. Double crochet in the next chain stitch.

Two spaces are now complete, and you've completed the first two squares on the chart.

7. Repeat Steps 4 through 6 for each square in Row 1.

Row 1 of the chart is now complete.

8. To continue working the swatch, work in blocks and spaces following the chart in Figure 13-12.

Read all odd-numbered rows from right to left and all even-numbered rows from left to right. Fasten off at the end of the last row.

**Figure 13-12:**  
Filet crochet  
chart and  
key for  
working a  
practice  
swatch  
using blocks  
and spaces.

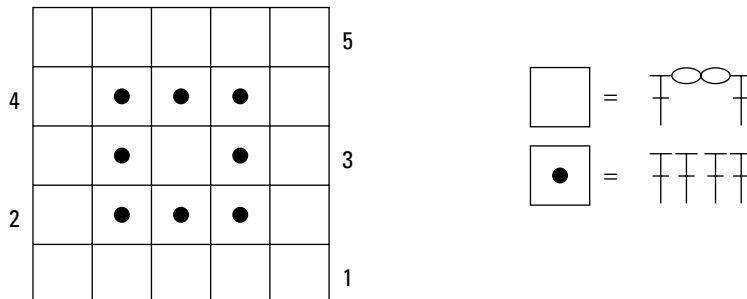



When working a filet crochet design, it's really easy to see when you've got it right or if you've made a mistake. Squares will line up on top of each other, so whether the squares contain spaces or blocks, every three stitches that make up a square will be in alignment.

### *Decreasing spaces and blocks*

Sometimes filet crochet designs require you to decrease spaces or blocks, usually to create an interesting border or edge shape. Decreasing is always done at the beginning or end of a row, never in the middle.

To decrease one space or block at the beginning of a row:

1. **Slip stitch in each of the first 3 stitches.**
2. **Chain 3 for the first double crochet of the next space or block.**
3. **Continue following the chart across the row.**



To decrease more than one space or block at the beginning of the row, simply slip stitch in each stitch across for the number of spaces or blocks that you're decreasing.

To decrease one space or block at the end of a row:

1. **Work the chart across the row until you reach the last 3 stitches (the beginning of the last space or block).**
2. **Turn your work, leaving the remaining stitches unworked.**



To decrease more than one space or block at the end of a row, work the row according to the chart, then stop crocheting when you've completed all the spaces or blocks. Turn your work and begin the next row.

## *Materials and vital statistics*

- ✓ **Yarn:** DMC "Cebelia" size 20 crochet thread (100% mercerized cotton), Article #167 (1.75 oz. [50 g], 405 yds [370 m] each ball): 1 ball of Blanc (white)
- ✓ **Hook:** Steel crochet hook size 6 U.S. or size needed to obtain gauge
- ✓ **Measurements:** 3¼ in. wide x 13 in. long
- ✓ **Gauge:** 5 spaces = 1½ in.; 7 rows dc = 1 ½ in.
- ✓ **Stitches used:** Chain stitch (ch), slip stitch (sl st), double crochet (dc). **Filet st:** Dc in dc, ch 2, skip next 2 sts: 1 space made. Dc in dc, dc in each of next 2 sts: 1 block made. **To dec 1 space at beg of row:** Sl st to designated dc, ch 3 (first dc) to beg row. **To dec one space at end of row:** Work to designated dc, then *turn* to beg next row.

This design uses blocks to create a border around the entire edge of the design. After you make the foundation chain, Row 1 writes out the instructions for the first row of the chart (read from right to left), then you continue to work the chart from Row 2, which you read from left to right.

## *Directions*

**Foundation chain:** Ch 33 + 3 (first dc).

**Row 1:** Dc in 4th ch from hook, dc in each ch across (first row of chart complete — 11 blocks), *turn*.

**Rows 2–61:** Work in blocks and spaces, foll chart (see Figure 13-13). Read all odd-numbered rows from right to left, all even-numbered rows from left to right. Fasten off at end of last row.

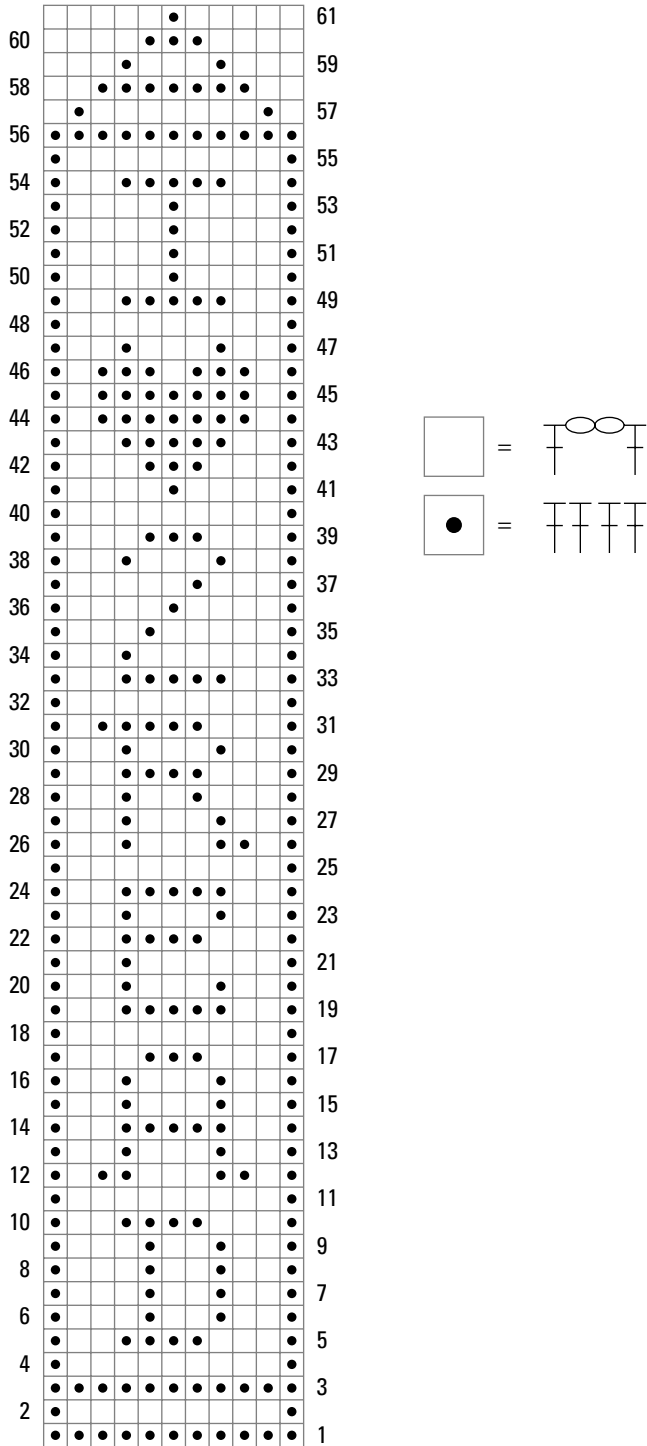

**Figure 13-13:**  
Bookmark  
chart  
and key.



**Finishing:** Using liquid starch, block the finished piece as follows:

1. Hand wash the design gently in cold water with mild soap, rinsing several times to remove all soap residue.
2. In a separate clean tub, prepare liquid starch solution according to the directions on the bottle.
3. Immerse the crocheted piece in the solution and allow the solution to completely penetrate the fabric.
4. Prepare a blocking surface large enough to accommodate the design, such as a piece of cardboard or foam board wrapped in plastic.
5. Remove the item from the solution and blot it with a clean towel to remove any extra solution.
6. Using rustproof straight pins, pin the design onto the blocking board to the required dimensions, taking care to shape any stitch patterns.
7. Blot the design again to remove any excess solution that may still remain.
8. Allow the piece to dry completely before removing the pins.

## Heartland Window Valance

The design of this window valance is a variation of one that has been around for many, many years. The pattern incorporates all the basic filet stitches: spaces, blocks, bars, and lacets (see Figure 13-14). Using a heavier-weight yarn increases the size of the design, making it suitable to hang at the top of a window.

**Figure 13-14:**  
Because you can add as many panels as you need, you can make this window valance to fit any size window.

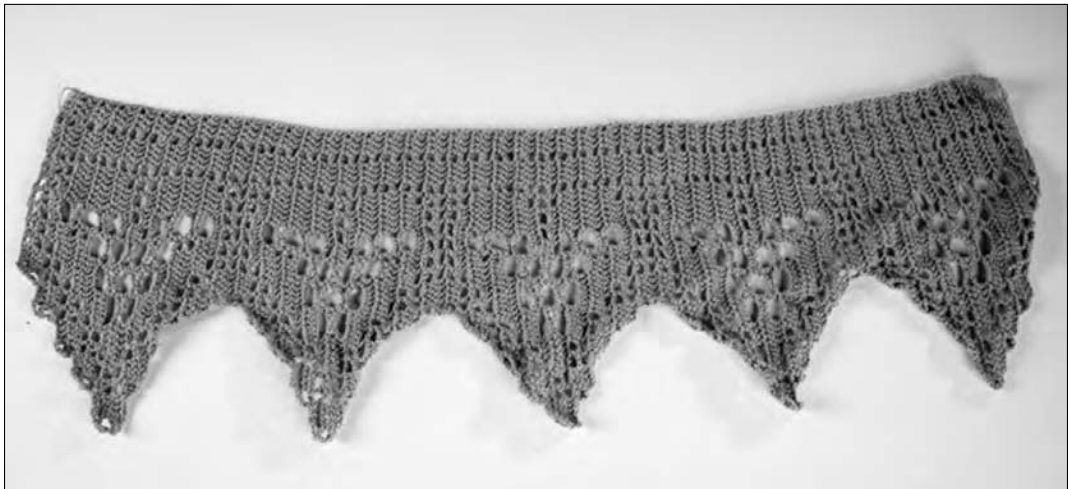

### *New skill: Fancy filet crochet stitches*

Filet crochet includes stitches called *bars* and *lacets*, in addition to spaces and blocks (see the “New skill: Basic filet crochet stitches” section under the bookmark project). Both lacets and bars are worked across two spaces or blocks in the previous row, as opposed to just one. They aren’t any harder to make; they just lend a decorative touch.

### Creating lacets

Lacets resemble V's, and it is the only filet crochet stitch to use a stitch other than the chain stitch and double crochet. The center of the V is formed with a single crochet stitch as follows:

1. Work the first double crochet as you would to begin a regular space or block.
2. Chain 3.
3. Skip the next 2 stitches.
4. Single crochet in the next stitch.
5. Chain 3.
6. Skip the next 2 stitches.
7. Double crochet in the next double crochet to complete 1 lacet (see Figure 13-15).

**Figure 13-15:**  
A lacet  
spanning  
two spaces.

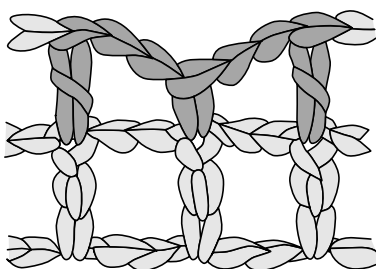

### Putting in bars

Bars are really nothing more than double spaces that cross over two spaces or blocks in the row below them. They are typically worked over a lacet, although not always. To make a bar:

1. Work the first double crochet as you would to begin a regular space or block.
2. Chain 5.
3. Skip the next 5 stitches or 2 spaces.
4. Double crochet in the next double crochet to complete 1 bar (see Figure 13-16).

**Figure 13-16:**  
A bar span-  
ning a lacet.

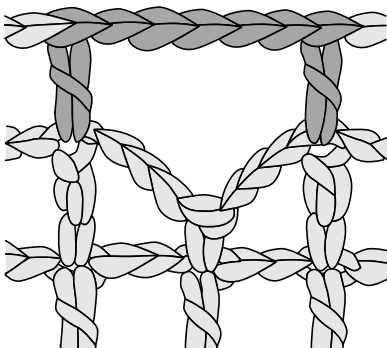

*Practicing with a swatch*

To get the hang of making lacets and bars, work this practice swatch using the chart and key in Figure 13-17 before jumping into the next project.

1. Chain 27 for the foundation chain.
2. Chain 2 to create the top of the first space.
3. Double crochet in the 8th chain stitch from the hook to create the first space.
4. Chain 2.
5. Skip the next 2 chain stitches.
6. Double crochet in the next chain stitch.

Two spaces are now complete, and you've completed the first 2 squares on the chart.

7. Repeat Steps 4 through 6 for each square in Row 1.

Row 1 of the chart is now complete.

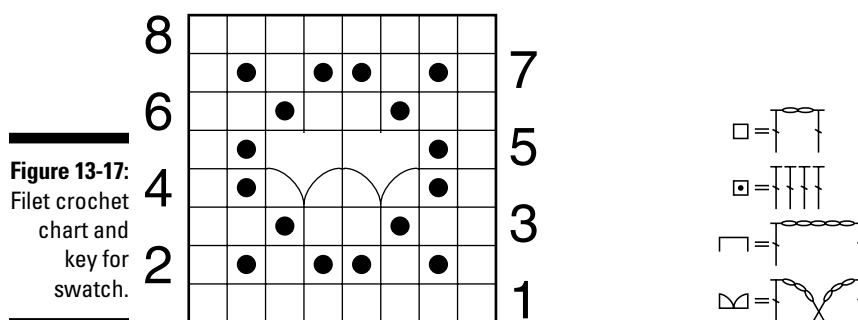

8. To continue working the swatch, work the blocks, spaces, lacets, and bars following the chart.

Read all odd-numbered rows from right to left and all even-numbered rows from left to right. Fasten off at end of last row.

*Increasing spaces and blocks*

This design has a shaped lower edge, so to create this detail, you need to increase and decrease spaces at the beginning of specified rows. Many filet crochet pieces are symmetrical, so you need to be able to increase spaces and blocks at both ends, but for the sake of clarity, the instructions below only show you how to increase spaces at the beginning of a row, which is all you need to complete this design. (Turn to the “New skill: Basic filet crochet stitches” section in the bookmark project to find out how to make spaces and blocks.)

To increase a space at the beginning of a row:

1. When you reach the end of the row that precedes the row you're going to increase, turn your work, then chain 2 for the base of the first increase space.
2. Chain 3 more for the turning chain of the row's first double crochet.
3. Chain 2 more for the top of the first space.
4. Double crochet in the 8th chain from the hook (see Figure 13-18a).

Now you've completed one space increase, as shown in Figure 13-18b.

**Figure 13-18:**  
Increasing  
one space  
at the  
beginning  
of a row.

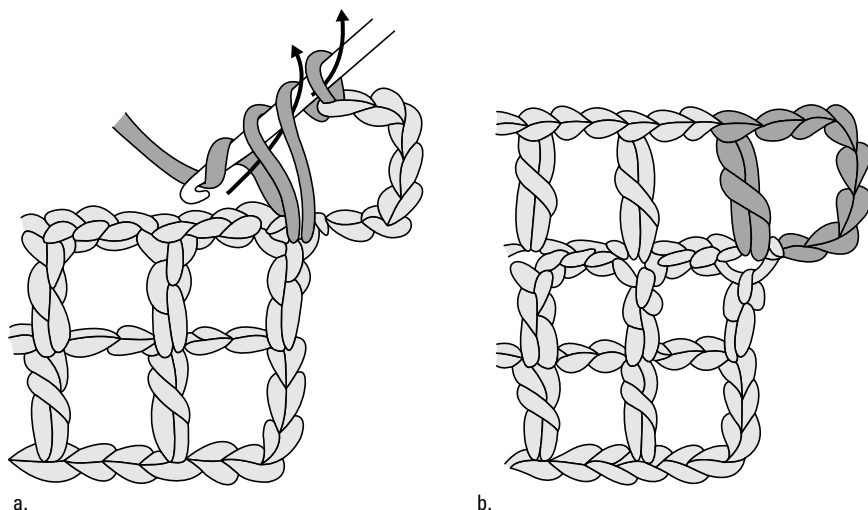

To increase a block at the beginning of a row:

1. When you reach the end of the row that precedes the row you're going to increase, turn your work, then chain 2 for the base of the first increase block.
2. Chain 3 more for the turning chain of the row's first double crochet.
3. Double crochet in the 4th chain from the hook to complete the block's 2nd double crochet (see Figure 13-19a).
4. Double crochet in each of next 2 chain stitches to complete the first block, as shown in Figure 13-19b.

**Figure 13-19:**  
Increasing  
one block  
at the  
beginning  
of a row.

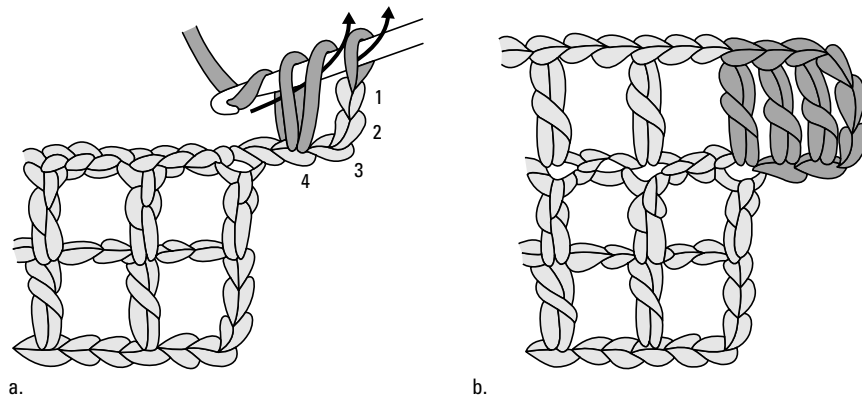

## Materials and vital statistics

- ✓ **Yarn:** Coats & Clark Red Heart “LusterSheen” sport-weight yarn (100% acrylic), Article #E721 (4 oz. [113 g], 335 yds [306 m] each skein): 1 skein of #0624 Sea Green will make a valance that is about 42 inches long. (Purchase more yarn as needed to make a valance that fits your window.)
- ✓ **Hook:** Crochet hook size E-4 U.S. or size needed to obtain gauge
- ✓ **Measurements:** Pattern repeat = 7 in. x 10 in.
- ✓ **Gauge:** 8 spaces = 3 in.; 5 rows dc = 3 in.

✓ **Stitches used:** Chain stitch (ch), slip stitch (sl st), single crochet (sc), double crochet (dc). **Filet st:** Dc in dc, ch 2, skip next 2 sts: 1 space made. Dc in dc, dc in each of next 2 sts: 1 block made. Dc in dc, ch 3, skip next 2 sts, sc in next st, ch 3, skip next 2 sts: 1 lacet made. Dc in dc, ch 5, skip next 5 sts, or 2 spaces: 1 bar made. **To inc 1 space and 1 block at beg of row:** Ch 11, dc in 8th ch from hook, dc in each of next 3 sts. **To dec 2 spaces at end of row:** Work to designated dc, then *turn* to beg next row.

This design incorporates almost all of the filet crochet skills you'll ever need. Keep in mind as you're working this project that the design is crocheted sideways and from the bottom edge to the top edge and back again.

## Directions

**Foundation chain:** Ch 36 + 3 (first dc) + 2 (first space).

**Row 1:** Dc in 8th ch from hook, dc in each of next 3 ch, (ch 2, skip next 2 ch, dc in next ch) 7 times, dc in each of next 3 ch, ch 2, skip next 2 ch, dc in next ch, dc in each of last 3 ch (first row of chart complete — 12 spaces and blocks), *turn*.

**Rows 2–19:** Work in blocks, spaces, bars, and lacets foll chart (see Figure 13-20). Read all odd-numbered rows from right to left, all even-numbered rows from left to right.

Rep Rows 2–19 for pat until valance reaches desired width to fit window. Fasten off at end of last row.

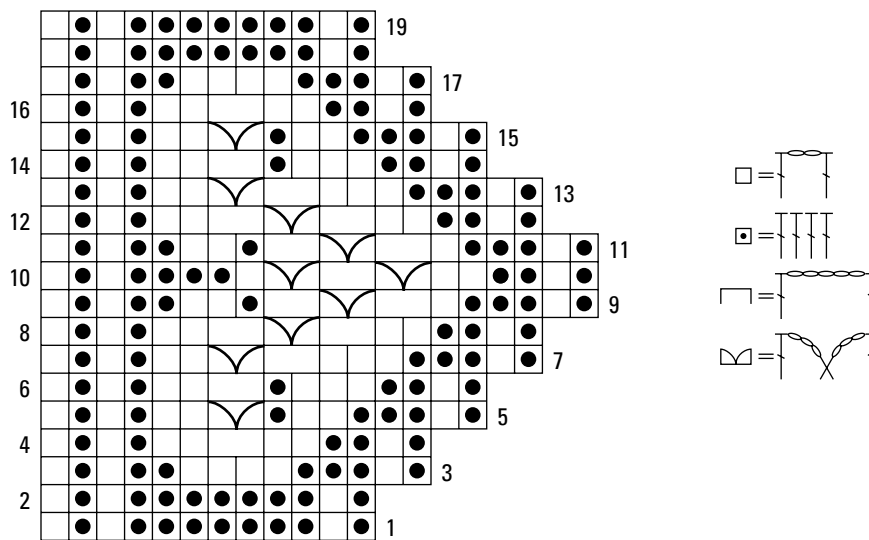

**Figure 13-20:** Window valance chart and key.

**Hanging the valance:** Use the second row of spaces down from the top edge to hang your valance. Thread a thin curtain rod through these spaces and hang in the desired window.

### *Variation: Using the pattern to create edging*

This design lends itself to adjustment. You can use a size 10 thread and a size 6 or 7 steel crochet hook to create shelf edging. Keep crocheting the pattern repeat until the edging is as wide as you want it.

To make a pillowcase edging, use size 20 crochet thread and a size 12 steel crochet hook. Work the pattern repeat until it reaches the desired width.

## Chapter 14

# Mixing Traditional Stitches with Contemporary Materials

---

### *In This Chapter*

- ▶ Creating a new design with the age-old granny square
  - ▶ Using thread crochet to dress up a plain pillowcase
  - ▶ Felting your way to a great carry-all
  - ▶ Working with hemp to crochet a basket
  - ▶ Crocheting with wire and beads to create a funky necklace
- 

**G**one are the days when women could pick up only a skein of basic 4-ply yarn or crochet thread to stitch their latest project. Today, you can use wire, hemp rope, and all sorts of fancy yarns to let your creativity shine. This chapter has a bunch of fun projects that incorporate old-time traditions with new ideas and materials. The granny square is showcased in a new light, while the pillowcase edging shows how you can create beautiful bedding on your own without having to rely on department stores.

This chapter also covers felting, a hot new craze in crochet. And finally, you can check out two projects that show how to use nontraditional materials to crochet. Browse through the projects, then give one a try. You just may discover a whole new side to your creativity!

## *Not Your Granny's Scarf*

Granny squares have made a comeback in a big way, but they certainly don't resemble those from when your granny may have worked the pattern. New advances in yarn affect how the granny square is crafted and viewed today, and this scarf is no exception (see Figure 14-1). Although the pattern itself remains the same, the colors and textures are strictly modern.

This is a great project if you're on the go, too, because you don't have to cart around a big unwieldy piece. Each square is made separately, and then sewn together in a strip to form a wear-everywhere scarf.

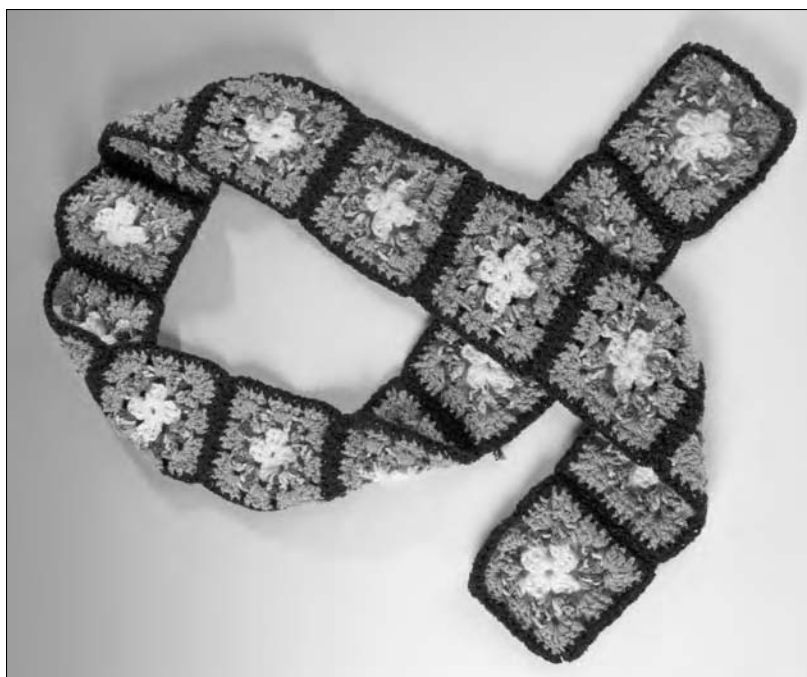

**Figure 14-1:**

The yarn used for this scarf brings the granny square into the 21st century.

## *Materials and vital statistics*

- ✓ **Yarn:** Coats and Clark “Moda Dea Metro” bulky-weight yarn (94% acrylic/6% nylon), Article #R143 (3.52 oz. [100 g], 124 yds [113 m] each skein): 1 skein each of
  - #9317 Vanilla (A)
  - #9863 Mocha Latte (B)
  - #9321 Wheat (C)
  - #9340 Chocolate (D)
- ✓ **Hook:** Crochet hook size J-10 U.S. or size needed to obtain gauge
- ✓ **Yarn needle**
- ✓ **Measurements:** Motif = 5¼ in. wide x 5¼ in. long; scarf = 5¼ in. wide x 82½ in. long
- ✓ **Gauge:** First 2 rnds of motif = 3½ in. in diameter
- ✓ **Stitches used:** Chain stitch (ch), slip stitch (sl st), single crochet (sc), double crochet (dc)

These granny square motifs work up quickly — each one is comprised of only four rounds. See Figure 14-2 for the stitch diagram. When changing the colors between each round, be sure to work over the yarn tails, that way you won’t be left with a lot of little ends to weave in when you’re done. Sew the motifs together end to end to form a long strip, and your scarf is complete.



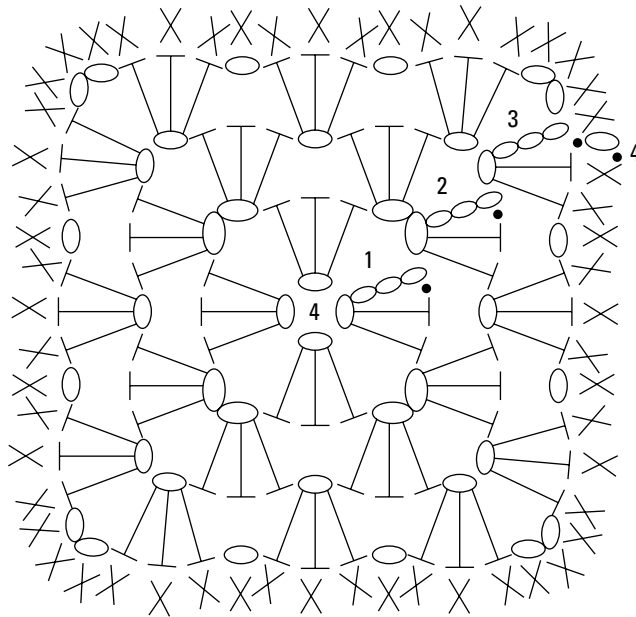

**Figure 14-2:**  
Motif stitch  
diagram.

## Directions

**Motif (make 15):**

**Center ring:** With A, ch 4 and close into a ring with one sl st in first ch.

**Rnd 1:** Ch 3 (first dc), ch 2 (first ch-2 space), (3 dc, ch 2) 3 times in ring, 2 dc in ring, sl st in first dc to join (4 ch-2 spaces). Fasten off A, join B.

**Rnd 2:** With B, ch 3 (first dc), ch 2 (first ch-2 space), 3 dc in first ch-2 space, ch 1, • (3 dc, ch 2, 3 dc) in next ch-2 space, ch 1 •, rep from • to • twice, 2 dc in first sl st, sl st in first dc to join. Fasten off B, join C.

**Rnd 3:** With C, ch 3 (first dc), ch 2 (first ch-2 space), 3 dc in first ch-2 space, ch 1, • 3 dc in next ch-1 space, ch 1, (3 dc, ch 2, 3 dc) in next ch-2 space, ch 1 •, rep from • to • twice, 3 dc in next ch-1 space, ch 1, 2 dc in first sl st, sl st in first dc to join. Fasten off C, join D.

**Rnd 4:** With D, ch 1, sc in each st and each ch-1 space around, working 3 sc in each ch-2 corner space, sl st in first sc to join. Fasten off.

**Assembly:** With right sides facing, using yarn needle and D, matching stitches across short edges, sew motifs together forming a strip that is 1 motif wide by 15 motifs long.

## Variation: Making a cozy afghan

The granny squares used for this scarf would also make a great afghan. To make one that is approximately 42 in. by 52 in. in size, you need 3 skeins of each yarn color. Following the directions above:

1. Make 80 motifs.
2. With right sides facing, sew motifs together to form an afghan 10 motifs wide by 8 rows in height.
3. Stitch the border:

With right side facing, join D in top right-hand corner stitch, ch 1, • 3 sc in corner stitch, sc in each st across to next corner •, rep from • to • around, sl st in first sc to join. Fasten off.

## *Shells and Lace Pillowcase Edging*

The design of this pillowcase edging (see Figure 14-3) was popular years ago, especially when women were still putting together hope chests for their daughters. A beautifully made bed is something that has never gone out of style, though, and the pillowcase edging here allows you to create a look that you won't see in any store.

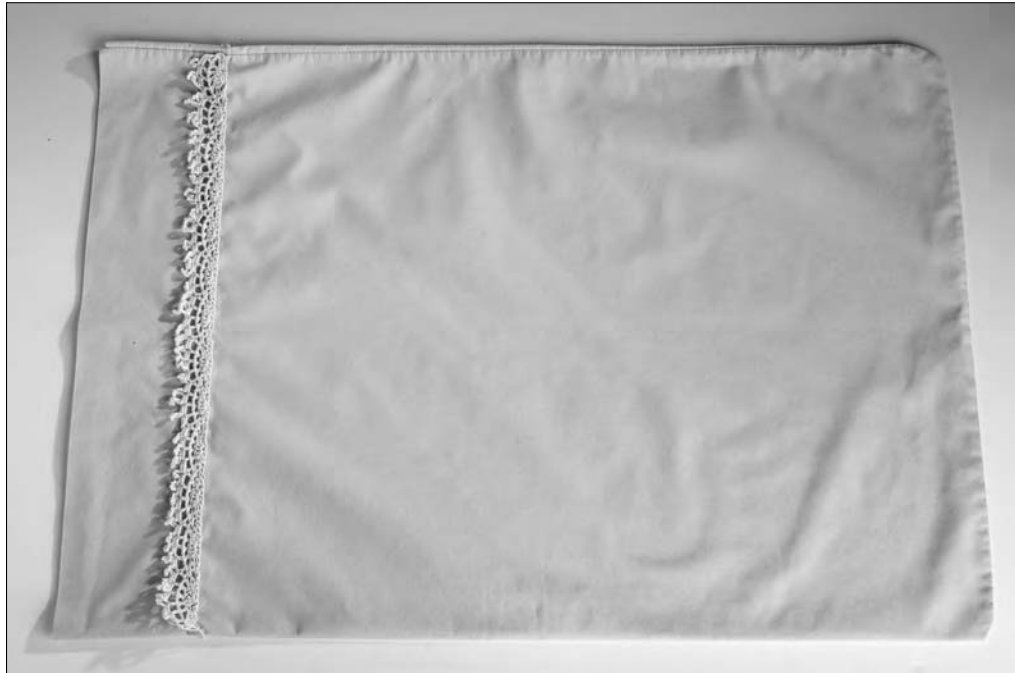

**Figure 14-3:**  
Dress up  
your pillows  
with this  
elegant  
edging.

When you decide to add edging to something, you can choose from literally hundreds of different edging designs. This one incorporates a variation of the shell stitch and works up into a narrow band that you sew across the front of the pillow. Make it in the beige color I use here, or go for a brighter look to add some pizzazz. This project is good for an intermediate-level crocheter, mainly because you use crochet thread, which is much finer and can be harder to work with. Don't let that put you off, though. Thread crochet makes some really beautiful designs.

## Materials and vital statistics

- ✓ **Yarn:** DMC “Cebelia” size 10 crochet thread (100% double mercerized cotton), Article #167G (1.75 oz. [50 g], 284 yds [260 m] each ball): 1 ball of #712 ecru makes several edgings
- ✓ **Hook:** Steel crochet hook size 4 U.S. or size needed to obtain gauge
- ✓ **Sewing needle and matching sewing thread**
- ✓ **Measurements:** 1½ in. wide x 19½ in. long
- ✓ **Gauge:** 3 pat repeats = 4 in.
- ✓ **Stitches used:** Chain stitch (ch), slip stitch (sl st), single crochet (sc), double crochet (dc). **Shell:** • 5 dc in same st •. **Cluster:** • 2 dc (half closed and joined together) worked across 2 designated sts •. **Picot:** • Ch 6, sl st in 3rd ch from hook •. (For refreshers on the shell, cluster, and picot stitches, turn to Appendix A.)

This is a great pattern to crochet for someone who’s relatively new to thread crochet. It’s not too complicated, yet the results look like you’ve been crocheting for years. The design is actually an expanded shell pattern (see Figure 14-4), one that you’ll likely see if you do any amount of thread crochet. You may find that the edges curl a bit as you work, but once you’re finished, wet the edging, shape it, lay it flat to dry, and it’ll be just fine.

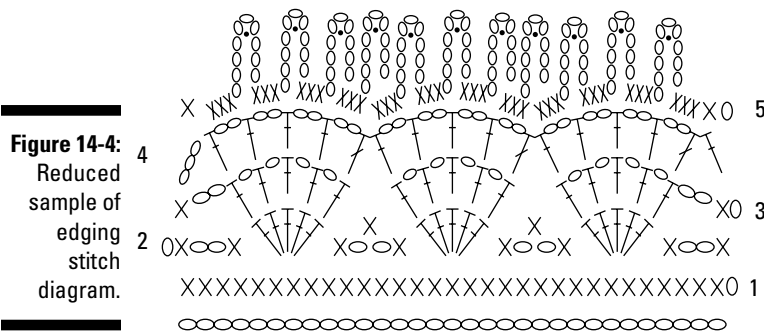

## Directions



The length of this edging is long enough to cover the edge of one side of a standard pillowcase. If you’d like to make your edging go all the way around the pillow, or if you want to make a matching edging for your sheets, make a foundation chain that is long enough for your needs and is a multiple of 9 sts + 5 to accommodate the pattern.

**Foundation chain:** Ch 122.

**Row 1:** Sc in 2nd ch from hook, sc in each ch across (121 sc), *turn*.

**Row 2:** Ch 1, sc in first sc, ch 2, skip next 2 sc, sc in next sc, • skip next 2 sc, shell in next sc, skip next 2 sc, sc in next sc, ch 2, skip next 2 sc, sc in next sc •, rep from • to • across (13 shells made), *turn*.

**Row 3:** Ch 1, sc in first sc, ch 2, • dc in first dc of next shell, (ch 1, dc in next dc) 4 times, sc in next ch-2 space •, rep from • to • across to within last shell, dc in first dc of last shell, (ch 1, dc in next dc) 4 times, ch 2, skip next ch-2 space, sc in last sc, *turn*.

**Row 4:** Ch 3 (first dc), skip next ch-2 space, (dc in next dc, ch 2) 4 times, • work one cluster of 2 dc across next 2 dc, with first dc of cluster in next dc, skip next sc, and second dc of cluster in next dc, ch 2, (dc in next dc, ch 2) 3 times •, rep from • to • across to within last dc, work one cluster of 2 dc across next 2 sts, with first dc of cluster in next dc, skip next ch-2 space, and second dc of cluster in last sc, *turn*.

**Row 5:** Ch 1, sc in top of first cluster, 3 sc in first ch-2 space, • ch 6, sl st in 3rd ch from hook (picot made), ch 4, 3 sc in next ch-2 space •, rep from • to • across to within last 2 dc, skip next dc, sc in last dc. Fasten off.

**Finishing:** To sew this edging to the pillowcase, pin the first row of the edging, close to the foundation chain, to the right side of the pillowcase in the desired location. Using a sewing needle and matching thread (or a sewing machine and matching thread), sew the edging to the pillowcase across the entire front edge.

## Honey, I Shrunk My Bag

Creating this felted carry-all is really fun! You start with one design and end up with another. Felting is the hot new craze among crocheters, and with good reason. The resulting fabric is soft, warm, and extremely durable (see Figure 14-5).

What is felting? You've probably done it and not even realized it. Remember when you were learning how to do laundry, and you inadvertently put that wool sweater into the washer and dryer and ended up with a sweater that would fit a child? Well, that's what felting is all about. *Felting* is what happens to wool fibers when they're exposed to hot water and friction. The stitches fuse into a densely woven fabric that is strong, but still soft to the touch. Using wool yarn, you crochet your item several sizes larger than you want the finished design to be. Then you throw the project into the washer and dryer to fuse the strands of wool together. No two bags come out exactly the same, so you always end up with a one-of-a-kind design.



**Figure 14-5:**  
You intentionally shrink this carry-all after you're done crocheting.

## Materials and vital statistics

- ✓ **Yarn:** Lion Brand “Lion Wool” worsted-weight yarn (100% wool), Article #820 (3 oz. [85 g], 158 yds [144 m] each skein for solids; 2¾ oz. [78 g], 143 yds [131 m] each skein for multis):
  - 3 skeins of #140 Rose (MC)
  - 1 skein of #201 Autumn Sunset (CC)
- ✓ **Hook:** Crochet hook size K-10½ U.S. or size needed to obtain gauge
- ✓ **Measurements:** 22 in. wide x 12½ in. deep, excluding handles, and before felting
  - **Note:** The finished measurements after felting will vary, but the carry-all will be considerably smaller. The bag shown here measured 17 in. wide x 9 in. deep, excluding the handles, after felting.
- ✓ **Gauge:** First 2 rnds of base = 1¾ in.
- ✓ **Stitches used:** Chain stitch (ch), slip stitch (sl st), single crochet (sc), half double crochet (hdc)

The beauty of this design is that the stitches are basic, and when you get done, you don’t really see them at all. Whether you tend to crochet on the loose side or make your stitches tight, the final outcome will be unique. The felting process blends the stitches together, so the look you get is one of a solid fabric.

## Crafting the tote

You create the base and sides of the bag as you crochet by working in rounds, instead of making the pieces individually and putting everything together at the end.

### Base

**Foundation chain:** With MC, ch 62.

**Rnd 1 (wrong side):** Hdc in 3rd ch from hook, hdc in each of next 58 ch, 3 hdc in last ch, working across opposite side of foundation ch, hdc in each of next 58 ch, hdc in same ch as first hdc (122 hdc), sl st in turning ch to join.

**Rnd 2:** Ch 2 (first hdc), 2 hdc in next hdc, hdc in each of next 58 hdc, 2 hdc in each of next 3 hdc, hdc in each of next 58 hdc, 2 hdc in next hdc, hdc in same st as first hdc (128 hdc), sl st in first hdc to join, *turn*.

### Bag sides

**Rnd 1 (right side):** Ch 2 (first hdc), working in flps only, hdc in each hdc around (128 hdc), sl st in first hdc to join.

**Rnd 2:** Ch 2 (first hdc), working in both loops of sts, hdc in each hdc around (128 hdc), sl st in first hdc to join.

Rep Row 2 in the foll color sequence: 5 rows MC; 3 rows CC; 9 rows MC; 2 rows CC; 3 rows MC; 2 rows CC; 3 rows MC; 2 rows CC; 9 rows MC; 1 row CC.

**Last Row:** With MC, sl st in each hdc around. Fasten off.

## Getting the hang of the handles

**Row 1:** With right side facing, join MC in 11th st from side, ch 100, join with sl st in corresponding st on same side edge of bag being careful not to twist ch, sl st in next st on edge of bag, *turn*.

**Row 2:** Ch 1, sc in each st across handle, sl st in next st on side edge of bag, *turn*.

**Rows 3–4:** Rep Row 2. Fasten off.

Rep handle in corresponding sts on opposite side of bag.

## Finishing up with felting

When felting an item, it's just like washing any other article of clothing. Set the washer to the hot or warm/cool rinse cycle and the appropriate load size. If you're felting the piece by itself, a small or medium wash setting will do the trick. Start the washer, and add the recommended amount of detergent for the size load you're going to run. If you want, you can throw some like-colored items in with the piece to help increase the agitation (however, check the yarn label to see if it tells you whether the yarn is colorfast).

It's a good idea to check your piece periodically, once at least halfway through the cycle, then again every few minutes or so to make sure it's not felting (or shrinking) too much. (To check the piece, stop the washer and wait for everything to stop moving before you reach into the machine.) Take the bag out of the washer when it's felted to your satisfaction, or if, at the end of the cycle, you want a more felted look, just run the piece through again.

You can also felt the bag even more in the dryer. Put the item in the dryer on the regular setting, and run the dryer until the piece is almost dry. Don't worry if the shape is skewed — while the bag is still damp, lay it flat, adjust into the proper shape, and allow the piece to finish air drying. If your piece is felted to your satisfaction when it comes out of the washing machine, you can let it air dry completely. Lay the piece on a flat surface and shape to dry.



Don't forget to check the piece during the felting process. After the fibers are fused, you can't undo it.

## Variation: Felting? Fuhgeddaboudit!

If you really like the way the bag looks before the felting process, go ahead and use it that way. If it gets wet or dirty, don't worry — it won't automatically felt. Just hand wash the bag in cool water and lay flat to dry.

## Hemp Basket

Baskets have a multitude of purposes, from displaying dried flowers in the living room to holding pretty soaps in the bathroom. Large or small, square or round, they're one of the most useful items to have around the house. Now you can create your own baskets. This project uses hemp cord instead of yarn (see Figure 14-6), and one ball

will make enough baskets so you can have several to place around the house or share with friends. It also proves that you don't always have to crochet with yarn. Almost any flexible material will work. Just use your imagination!



**Figure 14-6:**  
After you see how handy this basket is, you'll want to shout, "Hemp, hemp, hooray!"

## *Materials and vital statistics*

- ✓ **Yarn:** Hemp jewelry cord (worsted-weight) (73 yds [67 m] each ball): 1 ball
- ✓ **Hook:** Crochet hook size J-10 U.S. or size needed to obtain gauge
- ✓ **Stitch marker**
- ✓ **Measurements:** 5½ in. in diameter across top x 2½ in. tall
- ✓ **Gauge:** First 4 rnds of base = 2¾ in. in diameter
- ✓ **Stitches used:** Chain stitch (ch), slip stitch (sl st), single crochet (sc)

The pattern for this basket is typical of any round item you may come across, such as hats. The difference is in the material. Hemp cord is a little stiffer than yarn, so you may have to work a little harder to create each stitch.

## *Building the base*

**Center ring:** Ch 4 and close into a ring with one sl st in first ch.

**Rnd 1:** Ch 1, work 4 sc in ring (4 sc), sl st in first sc to join.

**Rnd 2:** Ch 1, 2 sc in each sc around (8 sc), sl st in first sc to join.

**Rnd 3:** Ch 1, 2 sc in each sc around (16 sc), sl st in first sc to join.

**Rnd 4:** Ch 1, sc in each of first 3 sc, 2 sc in next sc, • sc in each of next 3 sc, 2 sc in next sc •, rep from • to • around (20 sc), sl st in first sc to join.

### *Working your way up the sides*

**Rnd 1:** Ch 1, working in blps of sts only, sc in each sc around (20 sc), *do not join*. Continue working in a spiral, marking beg of each rnd and moving marker up as work progresses.

**Rnd 2:** Working in both loops of sts, • sc in each of next 4 sc, 2 sc in next sc •, rep from • to • around (24 sc).

**Rnd 3:** Sc in each sc around (24 sc).

**Rnd 4:** • Sc in each of next 5 sc, 2 sc in next sc •, rep from • to • around (28 sc).

**Rnd 5:** Sc in each sc around (28 sc), sl st in first sc to join. Fasten off.

### *Variation: Making the basket just the right size*

You can make bigger or smaller baskets. Increase or decrease the size of your base, then the sides accordingly. If you want to make a taller basket, keep going up, up, and around until the basket is the height you want.

### *Variation: Using different sizes of hemp cord*

Hemp cord comes in different sizes. You can use a finer-weight cord and smaller hook, or a heavier-weight cord and a larger hook.

If you use a finer-weight cord, your basket will be smaller in size. You can compensate for this by making the base larger, then the sides taller to arrive at the same dimensions as above.

If you use a heavier-weight cord, the basket will be larger. If that's what you're looking for, then that's just fine, but if you want to keep it the same size, decrease the size of your base, and work the sides until they reach the desired height.

## *Wire-'n'-Beads Necklace*

The wire-'n'-beads necklace is another example of using a nontraditional material to crochet with. Wire is ideal and is readily available. If you look in the beading section of your local craft store, you'll find lots of it. Use wire that is 28 to 30 gauge (this is the most flexible). It also comes in lots of different colors. The design shown here is really simple (see Figure 14-7), and you can make the necklace in just a few hours. The stitches are worked loosely, and as is done here, you can add beads or a charm or two to give it an up-to-date look.



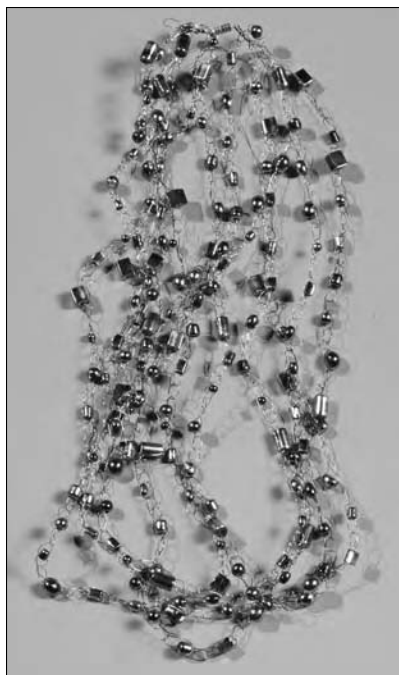

**Figure 14-7:**  
Chain  
stitches and  
beads make  
a funky  
statement.

## *Materials and vital statistics*

- ✓ **Yarn:** Wyr Knittr Wyr Pak 30-gauge copper-coated wire (40 yds [36 m] per spool): #02106 Jewels
- ✓ **Hook:** Crochet hook size H-8 U.S. or size needed to obtain gauge
- ✓ **Beads:** 180 Darice Jewelry Designer tie-dye glass bead #1981-70
- ✓ **Necklace clasp**
- ✓ **Measurement:** Each strand = approx 26 in. in length
- ✓ **Gauge:** 16 ch sts = 4 in.
- ✓ **Stitches used:** Chain stitch (ch). **Beaded chain stitch:** • Draw bead up close to hook, yo, draw wire through •.

Who ever would have thought of crocheting with wire? Well, wait until you try this one. Wire is really easy to work with. The only thing to remember is not to pull the stitches too tight because they're rather hard to undo. Leave them on the loose side, and don't worry if each one is not exactly the same size as the one before. This adds to the charm of the design.

## *Directions*

Make 6 strands: 2 each in pink, green, and blue.

**Foundation chain:** Thread 30 beads onto wire. Leaving a 3-in. tail, ch 2, • work one beaded chain st, ch 2 •, rep from • to • until all beads are used. Fasten off leaving a 3-in. tail.

**Assembly:** Lay strands side by side so that ends are even. Fasten ends to clasp according to directions for your type of clasp.

### ***Variation: Dressing up the look***

Use gold or silver wire and clear or matching gold or silver beads for a more elegant look.

### ***Variation: Complementing the necklace***

You can make a bracelet or anklet to wear when you wear the necklace. Reduce the number of beads you use (you'd probably need about 10 beads for each strand, so plan accordingly), and shorten the length of wire you chain. Assemble as above, and wrap the piece around your wrist or ankle.

# Part IV

## The Part of Tens

The 5<sup>th</sup> Wave By Rich Tennant

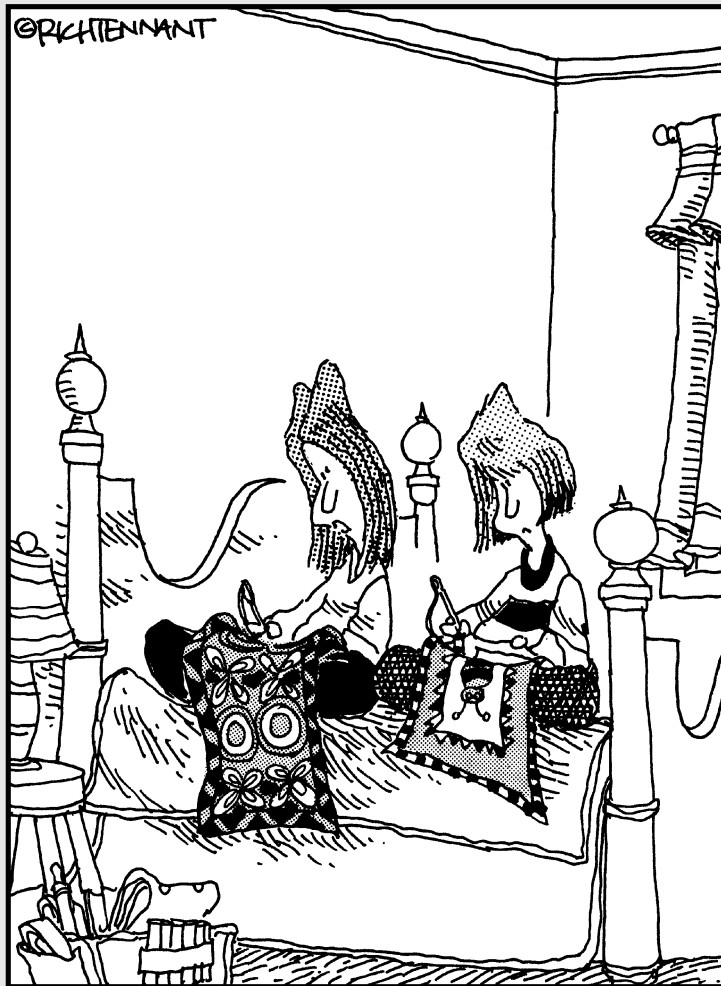

“So how old were you when you realized that metallic thread didn’t come from steel wool?”

### *In this part . . .*

**R**eady for some more fun? Read on for a whole bunch more patterns. This section features quick and easy designs, many that you can make in an hour or less. I also dedicate a chapter to the younger set as a way to draw a new generation into crochet when they see what they can make with their own two hands. And, if you've ever wondered how to take care of your crochet after you're finished, I include a short chapter about that, too.

## Chapter 15

# Nearly Ten Projects That Take an Hour or So

---

### *In This Chapter*

- ▶ Crocheting for immediate gratification
  - ▶ Some great gift-giving ideas
- 

Looking for a quick crochet fix? Then you've turned to the right place. This chapter provides a bunch of quick and easy designs that are guaranteed to satisfy you when your creative side needs a pick-me-up. If you're anything like me (and lots of others out there), sometimes you absolutely need to make something, but don't want to get involved in a lengthy project.

In this chapter, you'll find an array of projects ranging from home décor to fashion accessories and more. Many of them are great for gift-giving, or you can make a bunch to use as party favors. You use size 10 crochet thread to make several of the designs, so you can make more than one project using materials already at hand. And, as always, feel free to choose colors to suit your own wardrobe or color scheme.

## *Lacy Bookmark*

These bookmarks (see Figure 15-1) are for those who love to read and know the value of a good book. No more dog-eared pages to mark the spot where you left off. This design is quick enough, so you can make several in an evening. Then you'll have plenty to use for your reading and crochet books.

### *Materials and vital statistics*

- ✓ **Yarn:** Coats & Clark "South Maid" size 10 crochet thread (100% mercerized cotton), Article #D54 (350 yds [320 m] each ball): 1 ball of #458 Purple
- ✓ **Hook:** Steel crochet hook size 4 U.S. or size needed to obtain gauge
- ✓ **Measurements:** ¾ in. wide x 6¾ in. long, excluding tassel
- ✓ **Gauge:** First rnd = ¼ in.
- ✓ **Stitches used:** Chain stitch (ch), slip stitch (sl st), single crochet (sc), double crochet (dc). **Shell:** • 5 dc in same st •.



**Figure 15-1:**

These delicate bookmarks will stand up to the heaviest reading material.

These bookmarks work up really quickly — they're only two rounds (see Figure 15-2 for the stitch diagram). They also give you a great opportunity to work with thread without having to delve into a large project.

## Directions

**Foundation chain:** Ch 50.

**Rnd 1:** Sc in 2nd ch from hook, sc in each ch across to within last ch, 3 sc in last ch, working across opposite side of foundation ch, sc in each sc across to within last ch, 2 sc in last ch (100 sc), sl st in first sc to join.

**Rnd 2:** Ch 1, sc in first sc, • skip next 2 sc, shell in next sc, skip next 2 sc, sc in next sc •, rep from • to • 7 times, 3 sc in next sc, sc in next sc, • rep from • to • 8 times, 3 sc in last sc (16 shells), sl st in first sc to join. Fasten off.

**Finishing:** To make the tassel, wrap thread 20 times around a 2¼-inch piece of cardboard (I used a credit card). Slide the thread off the cardboard and cut one end. Tie a 6-inch length of thread securely around the center of the bundle, leaving equal length on each side. Fold the bundle in half, with the tie at the center top.

Wrap a second 6-inch length of yarn several times around the folded bundle approximately ¼ inch below the folded end. Tie tightly to secure and trim extra length. Using the remaining ends of thread from the first tie at the center top of the tassel, tie the tassel securely to one end of the bookmark. Weave in the extra lengths and trim ends even.

**Figure 15-2:**  
Stitch  
diagram for  
the lacy  
bookmark.  
(Tassel)

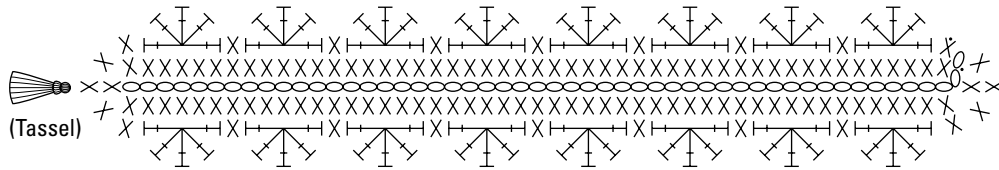

## Geometric Coaster Set

No more boring, round things to protect your tabletop. These coasters use bold colors and strong geometric shapes to help you serve drinks in style (see Figure 15-3). To create the designs, each coaster's unique design is depicted on a chart, instead of writing out each row. After you get used to following a chart, you'll find that the chart is much easier to "read" than if the instructions were written out row by row. The color changes involved and the charted pattern make this a good project for you if you've mastered crochet basics.



**Figure 15-3:**  
This  
geometric  
coaster set  
adds flair to  
your table.

### Materials and vital statistics

- ✓ **Yarn:** Paton's "Grace" light-weight yarn (100% mercerized cotton), Article #246060 (1.75 oz. [50 g], 136 yds [124 m] each skein): 2 skeins of #60005 Snow (MC) and 1 skein of #60040 Night (CC)
- ✓ **Hook:** Crochet hook size F-5 U.S. or size needed to obtain gauge

- ✓ **Measurements:** 4 in. wide x 4 in. long
- ✓ **Gauge:** 11 sc and 11 rows = 2 in.
- ✓ **Stitches used:** Chain stitch (ch), slip stitch (sl st), single crochet (sc)



When working from a chart, it's a good idea to make a copy of the chart before you get started. If necessary, you can enlarge it so it's easier to read, and you can also mark it up to keep track of where you are. Doing so leaves the original chart intact for future use.

Only one skein of each color is needed to complete the set of four coasters. However, because of the color changes in coasters 1 and 3, you need two skeins of white so you don't have to carry the yarn across too many stitches (see Chapter 4 for color-change information).

## Directions

Each coaster is made following a chart (see Figures 15-4, 15-5, 15-6, and 15-7). Read all odd-numbered rows from right to left, all even-numbered rows from left to right. When you begin this project, you'll see that the first couple of rows are written out in normal crochet fashion. This is typical when working from a chart, simply to get you going on the right track. After these rows are completed, you then "read" the chart for the balance of the pattern.



To change color, complete the last single crochet of the first color with the next color. Drop the first color to the wrong side to be picked up later. Attach separate balls of color as needed. Fasten off colors when they're not needed in the following row.

### Coaster 1

**Foundation chain:** With CC, ch 23.

**Row 1 (right side):** Sc in 2nd ch from hook, sc in each ch across (22 sc), *turn*. Row 1 of chart (Figure 15-4) complete.

**Row 2:** Join MC, ch 1, sc in first sc, drop MC to wrong side to be picked up later, with CC, sc in each of next 20 sc, drop CC to wrong side to be picked up later, join 2nd skein of MC, sc in last sc (22 sc), *turn*. Second row of chart complete.

**Rows 3–22:** Work in sc foll chart. Fasten off.

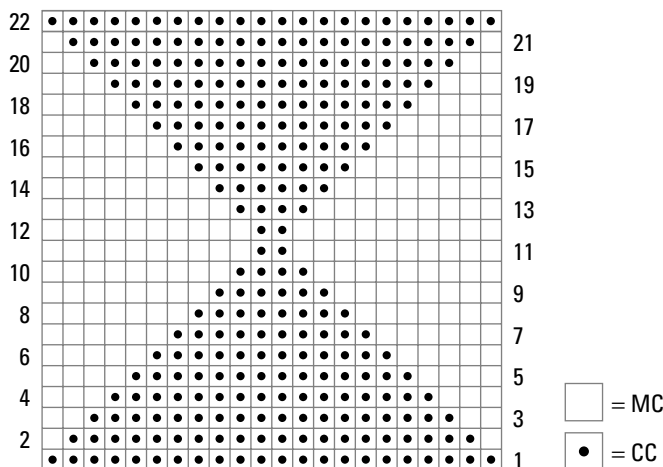

**Figure 15-4:**  
Coaster 1  
color chart  
and key.



**Edging:** With right side facing, join CC in any corner st, ch 1, 3 sc in corner st, sc in each st and each row-end st around, working 3 sc in each corner st, sl st in first sc to join. Fasten off.

### Coaster 2

**Foundation chain:** With CC, ch 23.

**Row 1 (right side):** Sc in 2nd ch from hook, sc in each ch across (22 sc), *turn*. Row 1 of chart (Figure 15-5) complete.

**Row 2:** Join MC, ch 1, sc in first sc, drop MC to wrong side to be picked up later, with CC, sc in each of next 21 sc (22 sc), *turn*. Second row of chart complete.

**Rows 3–22:** Work in sc foll chart. Fasten off.

**Edging:** With right side facing, join CC in any corner st, ch 1, 3 sc in corner st, sc in each st and each row-end st around, working 3 sc in each corner st, sl st in first sc to join. Fasten off.

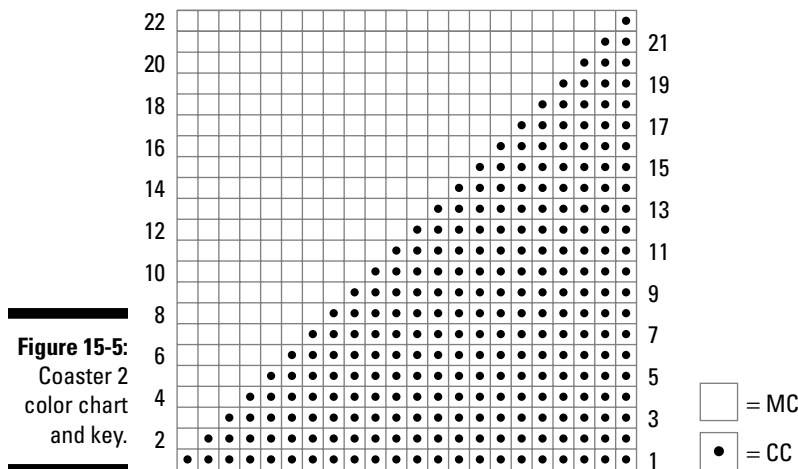

### Coaster 3

**Foundation chain:** With MC, ch 10, join CC, ch 2, drop CC to wrong side to be picked up later, join 2nd skein of MC, ch 11.

**Row 1 (right side):** Sc in 2nd ch from hook, sc in each of next 9 ch, drop MC to wrong side, pick up CC, sc in each of next 2 ch, drop CC to wrong side, pick up MC, sc in each of last 10 ch (22 sc), *turn*. Row 1 of chart (Figure 15-6) complete.

**Row 2:** Ch 1, sc in each of next 9 sc, drop MC to wrong side, pick up CC, sc in each of next 4 sc, drop CC to wrong side, pick up MC, sc in each of last 9 sc (22 sc), *turn*. Second row of chart complete.

**Rows 3–22:** Work in sc foll chart. Fasten off.

**Edging:** With right side facing, join CC in any corner st, ch 1, 3 sc in corner st, sc in each st and each row-end st around, working 3 sc in each corner st, sl st in first sc to join. Fasten off.

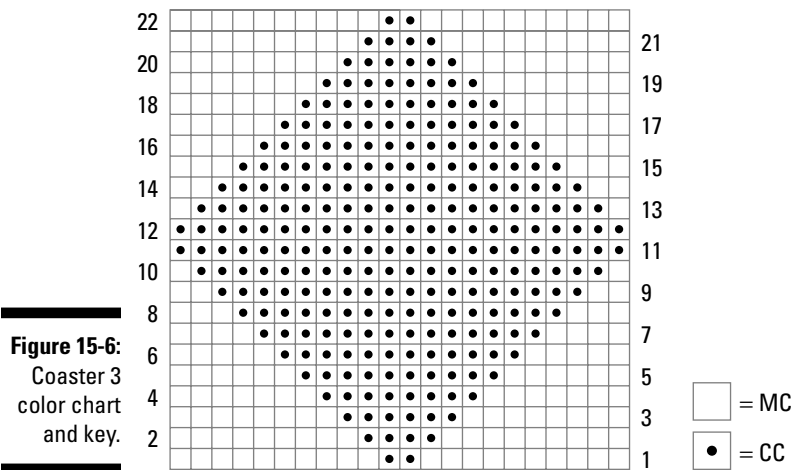

### Coaster 4

**Foundation chain:** With MC, ch 11, drop MC to be picked up later, join CC, ch 12.

**Row 1 (right side):** With CC, sc in 2nd ch from hook, sc in each of next 10 ch, drop CC to wrong side, pick up MC, sc in each of next 11 ch (22 sc), *turn*. Row 1 of chart (Figure 15-7) complete.

**Row 2:** With MC, ch 1, sc in each of next 12 sc, drop MC to wrong side, pick up CC, sc in each of next 10 sc (22 sc), *turn*.

**Rows 3–22:** Work in sc foll chart. Fasten off.

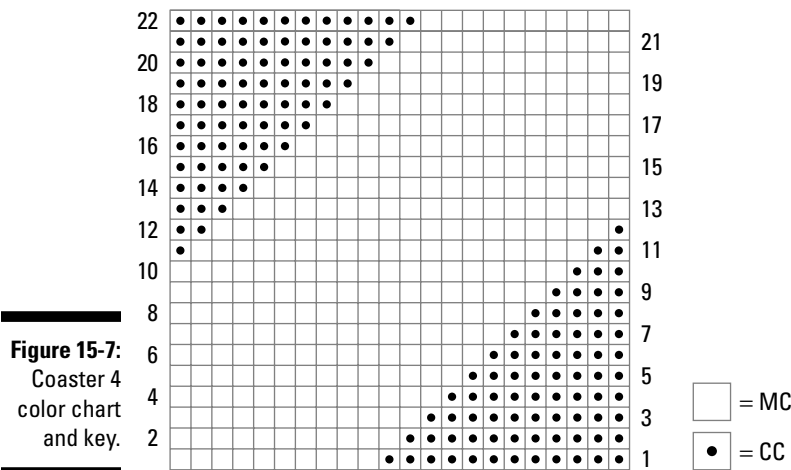

**Edging:** With right side facing, join CC in any corner st, ch 1, 3 sc in corner st, sc in each st and each row-end st around, working 3 sc in each corner st, sl st in first sc to join. Fasten off.

## *Variation: Creating coordinating table accessories*

To make matching placemats that measure approximately 12 in. x 16 in., crochet 12 individual coasters for each placemat and omit the edging. Instead of making them all the same pattern (that might get a little busy), try making half of them in solid colors, and alternate them with the patterned ones, or use the patterned squares as a border with a solid-colored center. When all are completed, lay out the squares 4 wide by 3 high in the desired pattern. Using a tapestry needle and matching yarn, sew the squares together. Crochet the edging around the entire placemat the same way you would for an individual coaster.

You can make a table runner in the same manner as the placemat. To figure out how many coasters you need, decide how wide (in inches) you want the runner to be, then divide by 4 inches (that's the size of each coaster). Then decide how long (in inches) you'd like it to be, and again divide by 4 inches. Obviously, the length and width have to be numbers that divide equally by 4 so you get an even number. For that reason, you may have to compromise a bit on the size.

## *Fun Fur Scrunchies*

Everyone uses these indispensable hair ties these days, young and old alike. Scrunchies are an easy way to dress up a ponytail or braids without a lot of fuss (see Figure 15-8). Each one of these patterns can be made in a short amount of time, and you can choose colors to match everything in your wardrobe.

These three scrunchies use a fun fur yarn with little bobbles of color throughout. Whether you make just one or all three, you're sure to be pleased with the outcome.

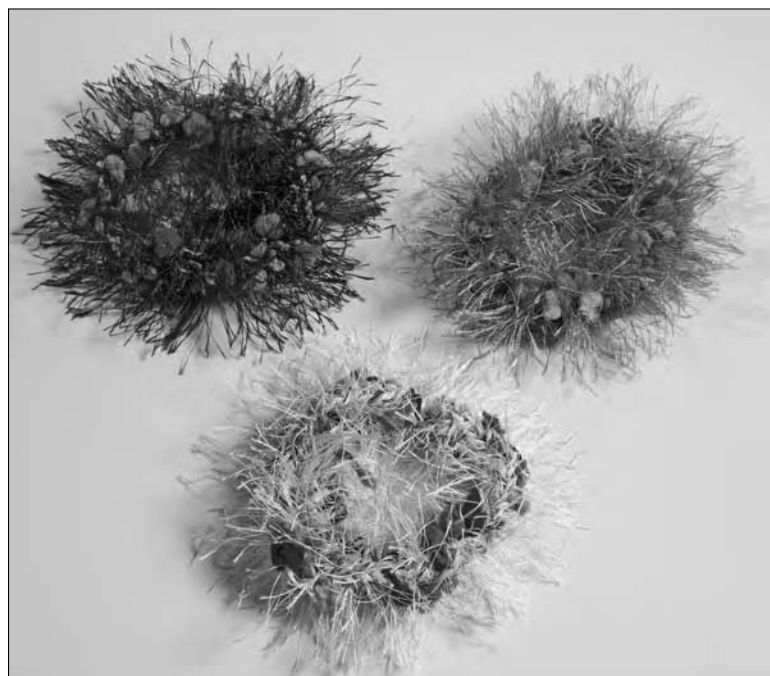

**Figure 15-8:**  
You can  
crochet  
scrunchies  
for every  
occasion.

## Materials and vital statistics

✓ **Yarn:** Lion Brand “Fancy Fur” eyelash yarn (55% polyamide/45% polyester), Article #220 (1.75 oz. [50 g], 39 yds [36 m] each skein): 1 skein each of

- #295 Party Pink
- #200 Wild White
- #254 Stained Glass

Each skein makes several scrunchies.

✓ **Hook:** Crochet hook size I-9 U.S. or size needed to obtain gauge

✓ **Elastic:** 8 in. of ¼-in. wide elastic for each scrunchy

✓ **Sewing needle and sewing thread**

✓ **Measurements:** ¾ in. in diameter

✓ **Gauge:** 4 sts = 1 in.

✓ **Stitches used:** Chain stitch (ch), slip stitch (sl st), single crochet (sc)

This is one of a very few designs that you’ll see where you don’t crochet a foundation chain or center ring. The elastic acts as the center ring, and you work your first round of stitches over the elastic in the same way that you would a crocheted center ring. Crochet the second round as you normally would and you’re done!

## Directions

With sewing needle and thread, sew ends of one 8-in. length of elastic together to form a circle.

**Rnd 1:** Working over elastic ring, sl st yarn onto elastic, ch 1, work 50 sc in ring (50 sc), sl st in first sc to join.

**Rnd 2:** Ch 1, 2 sc in each sc around (100 sc), sl st in first sc to join. Fasten off.

## Friendship Bracelet

These bracelets (see Figure 15-9) are reminiscent of the ones I used to make as a kid, though those weren’t crocheted. Of course, one was never enough, and we had to make several in different colors to wear at the same time. Although this design is worked in a pastel palette, bold-colored stripes or even solid colors would work just as well.

The bracelet is designed to fit loosely around the average adult wrist, but it’s easy enough to adjust the length. If you’re making these for the younger set, use the gauge to calculate how long to make your foundation chain for a smaller version.

**Figure 15-9:**

You can create friendship bracelets in any color combination.



## Materials and vital statistics

- ✓ **Yarn:** J & P Coats “Royale” Classic Crochet Thread, size 10 (100% mercerized cotton), Article #162 (400 yds [366 m] each ball for white; 350 yds [320 m] each ball for colors): 1 ball each of
  - #0423 Maize (A)
  - #0401 Orchid Pink (B)
  - #0201 White (C)
  - #0495 Wood Violet (D)
- ✓ **Hook:** Steel crochet hook size 6 U.S. or size needed to obtain gauge
- ✓ **1⅜ in. (size 0) sew-on snap**
- ✓ **Sewing needle and matching sewing thread**
- ✓ **Measurements:** ¾ in. wide x 8½ in. long
- ✓ **Gauge:** 9 sc = 1 in.; 5 rows sc = ½ in.
- ✓ **Stitches used:** Chain stitch (ch), single crochet (sc)

## Directions

**Foundation chain:** With A, ch 76.

**Row 1 (right side):** Sc in 2nd ch from hook, sc in each ch across (75 sc), *turn*. Fasten off A, join B.

**Row 2:** With B, ch 1, sc in each sc across (75 sc), *turn*. Fasten off B, join C.

Rep Row 2 in the foll color sequence: 1 row C; 1 row D; 1 row C; 1 row B; 1 row A. Fasten off.

**Finishing:** With sewing needle and thread, sew one side of snap to wrong side of bracelet ¼ in. in from one short edge, and other side of snap to right side of bracelet ¼ in. in from other short edge.



The fit of the bracelet can be adjusted at this point. If you'd prefer it to be looser, sew the snaps closer to the edge. If it needs to be tightened, sew the snaps farther from the edge.

### *Variation: Dressing the bracelet up with ribbon*

Instead of using snaps, you can fasten the bracelet with a pretty tie. Thread an 8-in. length of matching ribbon through each short end, and tie the ribbons together in a bow to secure the bracelet to your wrist.

### *Variation: Adding some width*

If you'd like a wider version of the bracelet, rep Row 2 above for 4 more rows in the following color sequence: 1 row D; 1 row C; 1 row B; 1 row A. This will give you a bracelet that is a little more than an inch wide.

## *Velvet Roses*

While these roses don't look exactly like the ones you'd pick out of your garden, they come pretty darn close (see Figure 15-10). The nice thing is you can choose the colors, and can even adjust their size. This is one of those designs where, by changing yarn and hook size, you can adjust the size of the finished design. And the finished project is 3-D, rather than flat, which makes it an intermediate-level project. Don't let this dimensional stuff throw you off, though. Flowers such as these are really fun to make, and after you get the hang of it, you'll see that they're no trouble at all.

You can use the roses to embellish hats, scarves, even jackets — add a pin back to them and you can attach them almost anywhere. Use your imagination and grow a whole bouquet!



**Figure 15-10:**  
Crocheted roses stay fresh all year long.

## Materials and vital statistics

- ✓ **Yarn:** Lion Brand Yarn “Lion Suede” bulky-weight yarn (100% polyester), Article #210 (3 oz. [85 g], 122 yds [112 m] each skein for solids; 2¾ oz. [78 g], 111 yds [101 m] each skein for multis): 1 skein each of
  - #113 Scarlet (A)
  - #204 Mountaintop (B)
  - #126 Coffee (C)
  - #202 Vineyard (D)
- ✓ **Hook:** Crochet hook size J-10 U.S. or size needed to obtain gauge
- ✓ **Measurement:** ¾ in. in diameter
- ✓ **Gauge:** First 2 rnds = 2¼ in. in diameter
- ✓ **Stitches used:** Chain st (ch), slip stitch (sl st), single crochet (sc), half double crochet (hdc), double crochet (dc), triple crochet (tr)

When you make crocheted flowers, the petals are created in rounds as you go. For three-dimensional flowers such as these, it’s a two-step process. You start with the petals in the center of the flower, then crochet chain loops behind these petals in the second round. On the third pass around, you crochet the actual petals in the chain loops from the previous row. You just keep working in this fashion until all petal rounds are complete. Refer to the stitch diagram (Figure 15-11) for placement of the stitches.

## Directions

**Center ring:** Ch 2.

**Rnd 1:** (2 sc, 2 hdc, 2 dc, tr) in 2nd ch from hook, sl st in first sc to join (7 sts).

**Rnd 2:** Working behind sts just made and into center ring, ch 3, skip first 2 sts, sl st bet last skipped st and next st, ch 3, skip next 2 sts, sl st bet last skipped st and next st, ch 3, skip next st, sl st bet last skipped st and next st, ch 3, skip next st, sl st bet last skipped st and next st, ch 3, sl st in first ch to join (5 ch-3 loops).

**Rnd 3:** Sl st in first ch-3 loop, ch 1, (sc, hdc, dc, hdc, sc) in loop, • sl st in next loop, ch 1, (sc, hdc, dc, hdc, sc) in loop •, rep from • to • around, sl st in first sl st to join (5 petals made).

**Rnd 4:** Working behind sts just made and into ch-3 loops of Rnd 2, skip first 2 sts on first petal, • sl st bet last skipped st and next st, ch 3, skip next 3 sts on current petal and next 2 sts on next petal •, rep from • to • around, sl st in first sl st to join (5 ch-3 loops).

**Rnd 5:** Sl st in first ch-3 loop, ch 1, (sc, hdc, 3 dc, hdc, sc) in loop, • sl st in next loop, ch 1, (sc, hdc, 3 dc, hdc, sc) in loop •, rep from • to • around, sl st in first sl st to join (5 petals made).

**Rnd 6:** Working behind sts just made and into ch-3 loops of Rnd 4, skip first 3 sts on first petal, • sl st bet last skipped st and next st, ch 3, skip next 4 sts on current petal and next 3 sts on next petal •, rep from • to • around, sl st in first sl st to join (5 ch-3 loops).

**Rnd 7:** Sl st in first ch-3 loop, ch 1, (sc, hdc, 5 dc, hdc, sc) in loop, • sl st in next loop, ch 1, (sc, hdc, 5 dc, hdc, sc) in loop •, rep from • to • around, sl st in first sl st to join (5 petals made). Fasten off.

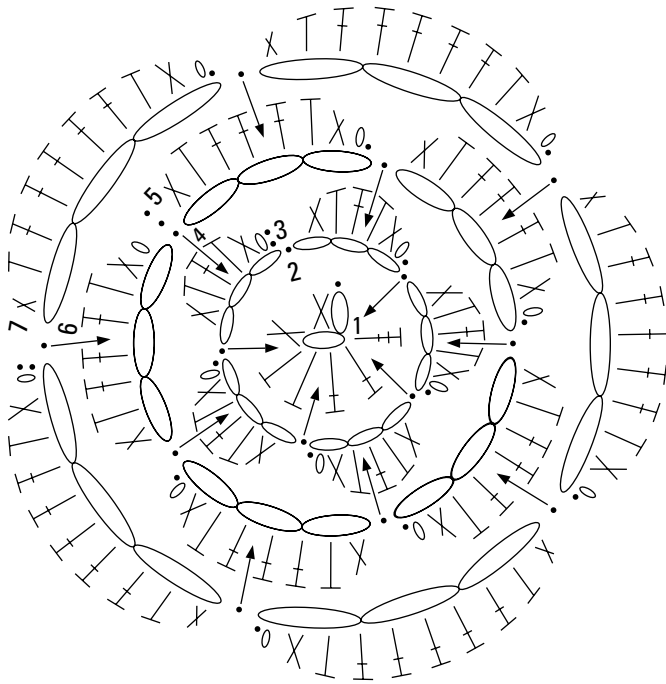

**Figure 15-11:**  
Stitch  
diagram for  
the velvet  
roses.

## Pocket Patches

Have you seen those jeans in the store that cost an arm and a leg? Many of them have simple embellishments on the back pockets that allow the stores to raise the prices through the roof. A friend of mine had on a pair of those jeans, and it inspired me to create this design (see Figure 15-12). You can now have those jeans at a fraction of the price. This design falls in the intermediate category for two main reasons — you're crocheting with thread and the construction. You make three small motifs, sew them together, then work a section off of the joined motifs. Take your time and you'll find it's not that difficult.





**Figure 15-12:**  
Create  
pocket  
patches  
to sew  
onto your  
favorite  
jeans.

## *Materials and vital statistics*

- ✓ **Yarn:** DMC “Traditions” size 10 crochet thread (100% cotton), Article #145 (2.3 oz. [65 g], 400 yds [366 m] each ball): 1 ball of Ecru
- ✓ **Hook:** Crochet hook size E-4 U.S. or size needed to obtain gauge
- ✓ **Tapestry needle**
- ✓ **Measurements:** 5½ in. wide x 3½ in. long
- ✓ **Gauge:** First 2 rnds of motif = 1¼ in.; finished motif = 1¾ in.
- ✓ **Stitches used:** Chain stitch (ch), slip stitch (sl st), single crochet (sc), double crochet (dc)

To create these pocket patches, you’ll need to crochet three motifs for each pocket, and then sew them together. After the motifs are joined, you work a pattern of coordinating stitches off the bottom edge to finish the design. Finally, you sew the patch onto the back pocket of your favorite pair of jeans. Refer to Figure 15-13 for the stitch and assembly diagram.

## *Creating and joining the motifs*

Follow these directions twice to make a patch for each pocket.

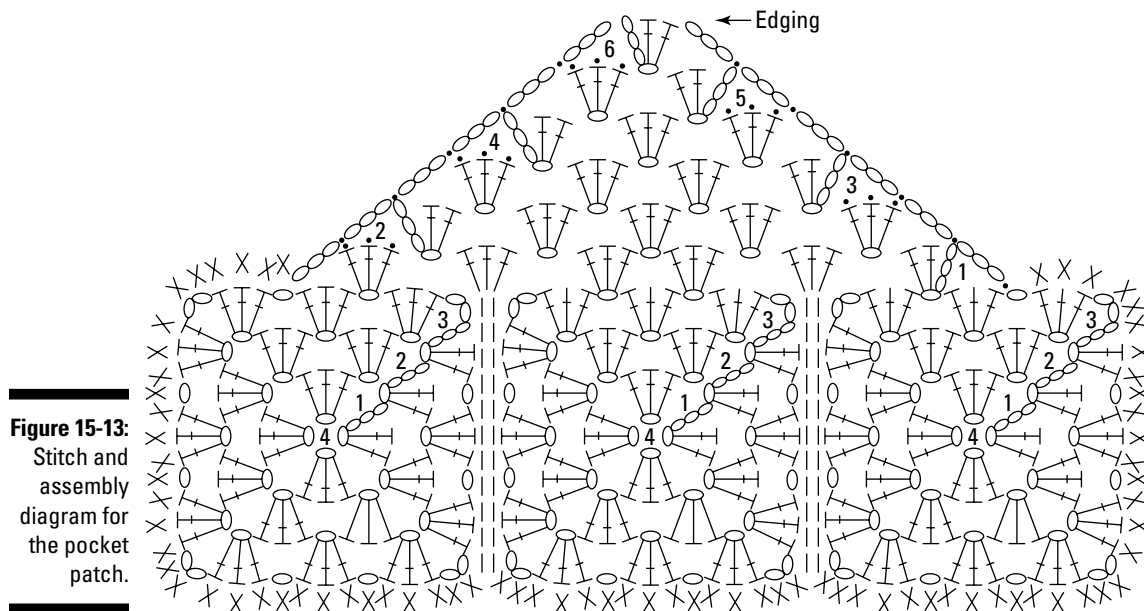

**Figure 15-13:**  
Stitch and  
assembly  
diagram for  
the pocket  
patch.

### ***Motif (make 3 for each pocket patch)***

**Center ring:** Ch 4 and close into a ring with sl st in first ch.

**Rnd 1:** Ch 3 (first dc), ch 2 (first ch-2 space), (3 dc, ch 2) 3 times in ring, 2 dc in ring, sl st in 3rd ch to join (4 ch-2 spaces).

**Rnd 2:** Ch 3 (first dc), ch 2 (first ch-2 space), 3 dc in first ch-2 space, ch 1, • (3 dc, ch 2, 3 dc) in next ch-2 space, ch 1 •, rep from • to • twice, 2 dc in first sl st, sl st in 3rd ch to join.

**Rnd 3:** Ch 3 (first dc), ch 2 (first ch-2 space), 3 dc in first ch-2 space, ch 1, • 3 dc in next ch-1 space, ch 1, (3 dc, ch 2, 3 dc) in next ch-2 space, ch 1 •, rep from • to • twice, 3 dc in next ch-1 space, ch 1, 2 dc in first sl st, sl st in 3rd ch to join. Fasten off.

### ***Assembly***

With right sides facing, using tapestry needle and crochet thread, sew motifs together, through back loops only, to form a strip three motifs wide (see Figure 15-13).

## ***Finishing the design and adding final touches***

**Row 1:** With right sides facing, skip first ch-2 corner space, skip next ch-1 space, join thread in next ch-1 space, ch 3 (first dc), 2 dc in ch-1 space, ch 1, 3 dc in joining seam, ch 1, skip next ch-2 corner space, (3 dc, ch 1) in each of next 2 ch-1 spaces, 3 dc in next joining seam, ch 1, skip next ch-2 space, 3 dc in next ch-1 space (6 groups of 3 dc), *turn*.

**Row 2:** Sl st to first ch-1 space, ch 3 (first dc), 2 dc in ch-1 space, • ch 1, 3 dc in next ch-1 space •, rep from • to • 3 more times (5 groups of 3 dc), *turn*.

**Row 3:** Sl st to first ch-1 space, ch 3 (first dc), 2 dc in ch-1 space, • ch 1, 3 dc in next ch-1 space •, rep from • to • 2 more times (4 groups of 3 dc), *turn*.

**Row 4:** Sl st to first ch-1 space, ch 3 (first dc), 2 dc in ch-1 space, • ch 1, 3 dc in next ch-1 space •, rep from • to • once (3 groups of 3 dc), *turn*.

**Row 5:** Sl st to first ch-1 space, ch 3 (first dc), 2 dc in ch-1 space, ch 1, 3 dc in next ch-1 space (2 groups of 3 dc), *turn*.

**Row 6:** Sl st to first ch-1 space, ch 3 (first dc), 2 dc in ch-1 space (1 group of 3 dc), *do not turn*.

### *Edging*

Working in row-end sts across side of pocket, • ch 3, sl st in first dc of next row •, rep from • to • 4 times, ch 3, sl st in next ch-1 space in next row, sc evenly around motif strip to first ch-1 space at beginning of Row 1, working 2 sc in each ch-2 corner space, rep from • to • across row-end sts to first dc in Row 6, sl st in first dc to join. Fasten off.

### *Finishing*

With tapestry needle and crochet thread, sew pocket patch to back pocket of jeans.

## Stemmed-Glass Markers

These little wine glass doodads (see Figure 15-14) have soared in popularity over the past few years, and with good reason. What better way to always know which glass is yours, instead of wondering if you're drinking someone else's drink.

Made with earring hoops, size 10 crochet thread, and a charm, you can whip one of these up in about 10 minutes. In an evening, you can have a whole bunch made to show off and use at your next gathering. They'd also make a wonderful hostess gift the next time you need one.



**Figure 15-14:**  
Stemmed-  
glass  
markers  
keep guests  
from sipping  
each other's  
chardonnay.

## Materials and vital statistics

- ✓ **Yarn:** J & P Coats “Royale” Classic Crochet Thread, size 10 (100% mercerized cotton), Article #162 (350 yds [320 m] each ball): 1 ball of #0401 Orchid Pink makes many
- ✓ **Hook:** Steel crochet hook size 6 U.S. or size needed to obtain gauge
- ✓ **7/8-in. earring hoop wires with loop on one end**
- ✓ **Small charm with hanging loop**
- ✓ **Clear nail polish**
- ✓ **Measurement:** 1¼ in. in diameter
- ✓ **Gauge:** 6 sc = ½ in.
- ✓ **Stitches used:** Chain stitch (ch) slip stitch (sl st), single crochet (sc). **Picot:** Sc in 3rd ch from hook (see Appendix A for detailed how-to’s).



The earring hoops used in this design generally come in packages with quite a few included, so you’ll have enough hoops to make as many of these markers as you need. When picking out the charms, don’t forget to vary the design so everyone has his or her own. If all the charms are the same, it kind of defeats the purpose!

This is one of those designs where you don’t actually crochet a foundation chain or center ring. The first row is worked directly around the hoop of the earring, then you work back to finish the second row, adding the charm as you go (see Figure 15-15 for the stitch diagram).

## Directions

Thread charm onto crochet thread before beginning.

**Row 1:** Starting at loop end of hoop, join yarn to earring hoop with sl st, ch 1, work 31 sc around hoop (31 sc), *turn*.

**Row 2:** Ch 1, sc in first sc, • ch 5, sl st in 3rd ch from hook (picot made), ch 3, skip next 4 sc, sc in next sc •, rep from • to • twice, draw charm up to hook, sl st around hanging loop of charm to secure, rep from • to • 3 times. Fasten off.

Apply clear nail polish to thread at loose end of earring hoop to prevent stitches from sliding off.

**Figure 15-15:**  
Stitch  
diagram of  
stemmed-  
glass  
marker with  
charm.

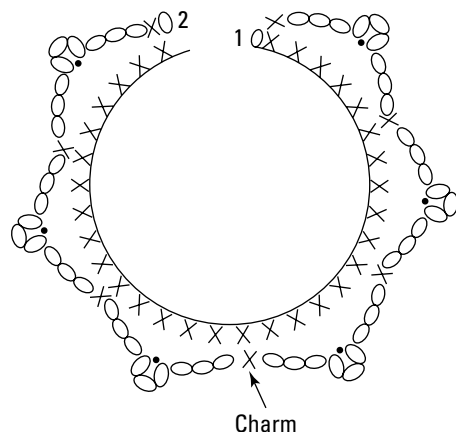

## *Variation: Making a marker set for every occasion*

These markers would make great additions to holiday parties as well as for the different seasons of the year: pastel threads for spring, black and orange with spooky charms for Halloween, green and red or metallic thread with tiny ornament charms for Christmas. The size 10 thread comes in every color of the rainbow, and the variety of charms available is endless. Use your imagination and create a set for all occasions.

## *Must-See Fur Frame*

Some pictures deserve to be shown off in a special frame, and this one does the trick (see Figure 15-16). Made with a long eyelash yarn, it's especially pleasing for tweens and teens to show off pictures of themselves and their friends. This project is suitable for you if your skills have advanced to an intermediate level. The yarn itself can be hard to work with (sometimes it's hard to see the stitches through the fur). And the large center ring can be a challenge. Just make sure not to twist it when you join the ends, and count your stitches as you go so you get the corners right on the first go-round.



**Figure 15-16:**  
You can't help but smile when you see a picture in a furry frame.

## *Materials and vital statistics*

- ✓ **Yarn:** Lion Brand Yarn “Fun Fur” bulky-weight yarn (100% polyester), Article #320 (1.75 oz. [50 g], 60 yds [55 m] each ball): 1 ball of #098 Ivory makes several
- ✓ **Hook:** Crochet hook size I-9 U.S. or size needed to obtain gauge

- ✓ **5 x 7 in. photo frame with 7/8-in. flat frame**
- ✓ **Clear-drying craft glue**
- ✓ **Measurements:** Inside dimensions = 4 5/8 in. wide x 6 5/8 in. long; outside dimensions = 6 1/2 in. wide x 8 1/2 in. long
- ✓ **Gauge:** 9 sc = 3 in.; 4 rows = 7/8 in.
- ✓ **Stitches used:** Chain stitch (ch), slip stitch (sl st), single crochet (sc)

This frame begins with a large center ring, which you have to be sure not to twist when you join the ends. In the first row, you create the corners, turning the ring into a square. Each successive row builds on the first, making it wider, so you'll have plenty of material to attach to the frame when you're finished.

## Directions

**Center ring:** Ch 80 and, without twisting ch, close into a ring with sl st in first ch.

**Rnd 1:** Ch 1, sc in each of next 21 ch, 3 sc in next ch, sc in each of next 17 ch, 3 sc in next ch, sc in each of next 21 ch, 3 sc in next ch, sc in each of next 17 ch, 3 sc in last ch (88 sc), sl st in first sc to join.

**Rnd 2:** Ch 1, sc in each of next 22 sc, 3 sc in next sc, sc in each of next 19 sc, 3 sc in next sc, sc in each of next 23 sc, 3 sc in next sc, sc in each of next 19 sc, 3 sc in next sc, sc in last sc (96 sc), sl st in first sc to join.

**Rnd 3:** Ch 1, sc in each of next 23 sc, 3 sc in next sc, sc in each of next 21 sc, 3 sc in next sc, sc in each of next 25 sc, 3 sc in next sc, sc in each of next 21 sc, 3 sc in next sc, sc in each of last 2 sc (104 sc), sl st in first sc to join.

**Rnd 4:** Ch 1, sc in each of next 24 sc, 3 sc in next sc, sc in each of next 23 sc, 3 sc in next sc, sc in each of next 27 sc, 3 sc in next sc, sc in each of next 23 sc, 3 sc in next sc, sc in each of last 3 sc (112 sc), sl st in first sc to join. Fasten off.

**Finishing:** With craft glue, glue crocheted piece to frame, matching inside and outside corners.

## Standout Luggage Tags

When traveling by plane these days, it seems that almost everyone has the same luggage, or at least bags that are similar enough to make it hard to tell yours apart from the hundreds of others that come spinning out into the baggage-claim area. These luggage tags (see Figure 15-17) make it easy for you to customize your bags so you don't have to spend time watching the carousel go round and round, grabbing for bags that aren't yours. And because these tags only use a small amount of yarn, they're also a great way to use up leftover scrap yarn.

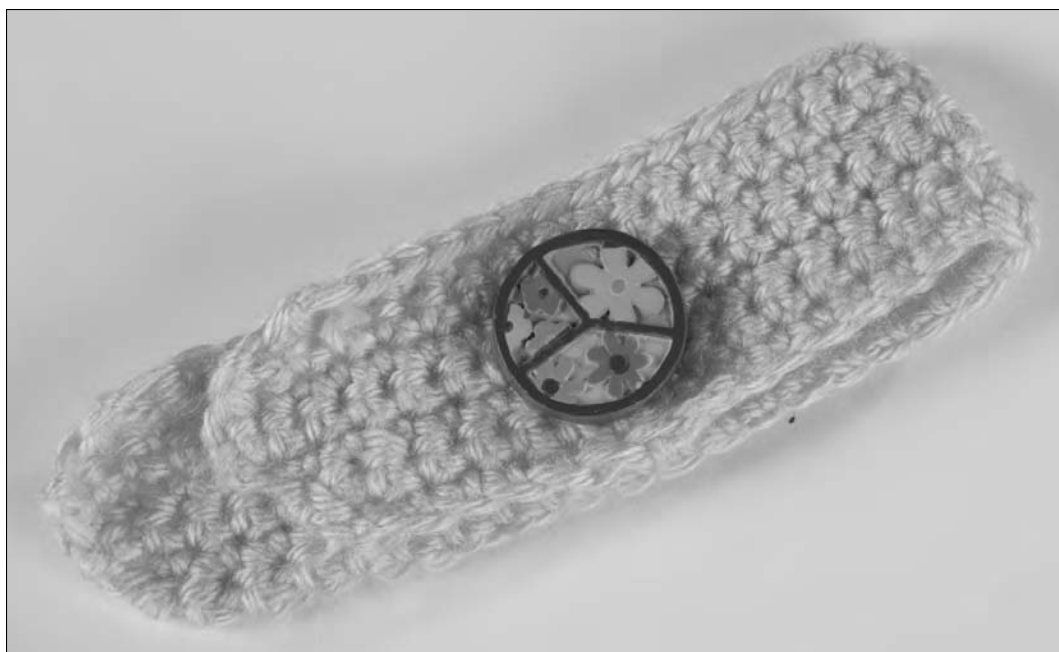

**Figure 15-17:**  
Make a tag  
to help  
you find  
your bag.

## *Materials and vital statistics*

- ✓ **Yarn:** Caron “Simply Soft Brites” worsted-weight yarn (100% acrylic), Article #H9700B (6 oz. [170 g], 330 yds [302 m] each skein): 1 skein of #9606 Lemonade makes many
- ✓ **Hook:** Crochet hook size H-8 U.S. or size needed to obtain gauge
- ✓ **One 1-in. shank button**
- ✓ **Tapestry needle**
- ✓ **Measurements:** 1½ in. wide x 10 in. long
- ✓ **Gauge:** 4 sc and 5 rows = 1 in.
- ✓ **Stitches used:** Chain stitch (ch), single crochet (sc). **Dec 1 sc:** • (Insert hook in next st, yo, draw yarn through st) twice, yo, draw yarn through 3 loops on hook •.

These luggage tags are really quick and easy to make, and you also get to practice making buttonholes without having to crochet a whole sweater. But don’t worry — buttonholes are a piece of cake to create. In this case, all you do is crochet a small chain where specified, skip a few stitches, then join the yarn back to the row, and you’re on your way again.

## *Directions*

**Foundation chain:** Ch 36.

**Row 1 (right side):** Sc in 2nd ch from hook, sc in each ch across (35 sc), *turn*.

**Row 2:** Ch 1, 2 sc in first sc, sc in each sc across to within last sc, 2 sc in last sc (37 sc), *turn*.

**Row 3:** Rep Row 2 (39 sc).

**Row 4:** Ch 1, 2 sc in first sc, sc in each of next 5 sc, ch 3, skip next 3 sc (buttonhole made), sc in each sc across to within last sc, 2 sc in last sc (41 sts), *turn*.

**Row 5:** Ch 1, dec 1 sc in first 2 sc, sc in each sc across working 3 sc in ch-3 space to within last 2 sc, dec 1 sc in last 2 sc (39 sc), *turn*.

**Row 6:** Ch 1, dec 1 sc in first 2 sc, sc in each sc across to within last 2 sc, dec 1 sc in last 2 sc (37 sc), *turn*.

**Row 7:** Rep Row 6 (35 sc). Fasten off.

**Finishing:** With right side facing, fold tag in half crosswise, forming a loop. Check loop to make sure it fits snugly around luggage handle and mark spot for button placement. Using tapestry needle and yarn, sew button in place.



## Chapter 16

# Ten-Plus Tips for Caring for Your Crochet

---

### *In This Chapter*

- ▶ What to do when the work is done
  - ▶ Maintaining the look of your crocheted pieces
  - ▶ How to properly store your pieces of art
- 

**N**ow that you've completed your design, the final step is making it look its best and making sure that it stays looking its best. Because of all the time you've invested, it would be a shame to have your project fall apart on the first wash, shrink to a baby-doll size, stretch so far out of proportion it's unrecognizable, or discolor by being improperly stored.

It's not difficult to preserve the beauty of the original finished piece, but you do need to take a few extra steps. Follow the appropriate tips given in this chapter to ensure that your work will stick around for a long time.

## *Be a Pack Rat: Save the Labels*

Don't throw out those yarn labels! Every yarn label has care instructions on it. Keep them organized in a binder, or keep a notebook of your projects with the yarn label attached. Write a note underneath the label with the name or description of the crocheted item so you'll have a handy reference when you need to launder that item. Figure 16-1 provides a complete list of care symbols and information about each one.

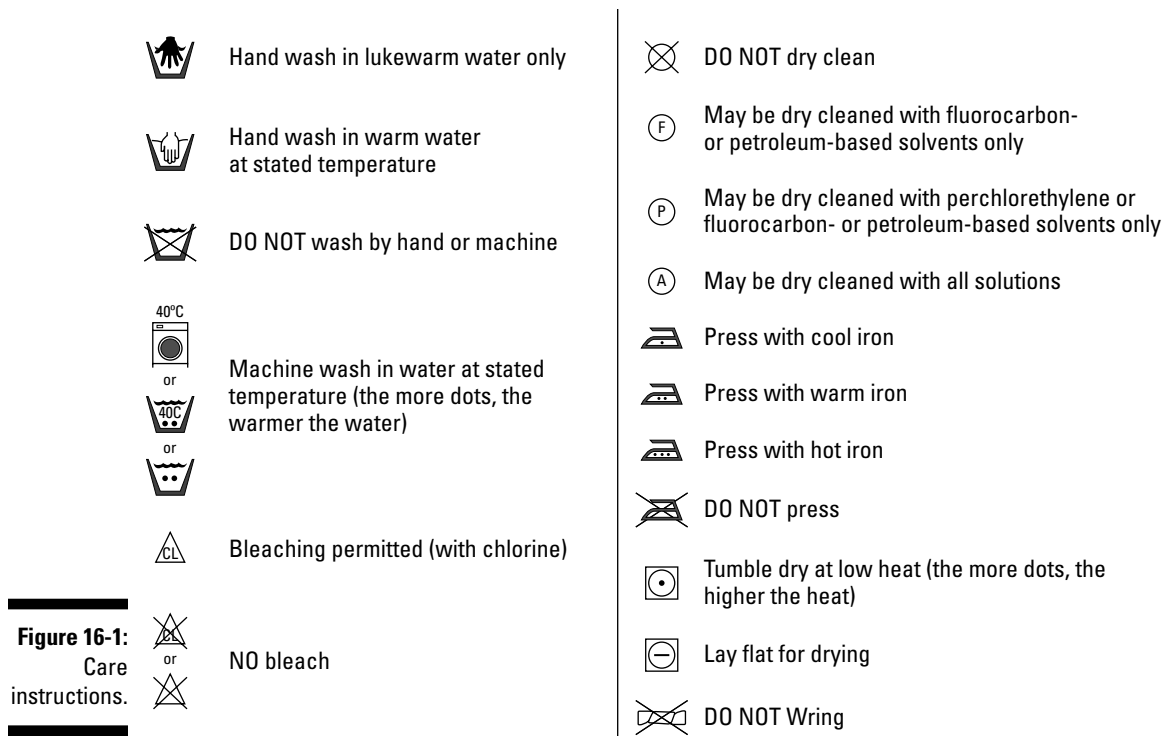

**Figure 16-1:**  
Care instructions.

## Show You Care: Attach Your Own Care Labels

Another way to know how to care for an item is to sew a care label (if appropriate) onto the item itself. These are available at craft stores and some yarn shops. Use a permanent ink pen to write care instructions on the label (*before* you attach the label to the item! You don't want to ruin all of your hard work by getting permanent ink on it). Attaching a care label works best for items such as garments and afghans. You can also include your name and the date you made the item, too.

The best way to attach the label is to sew it on with a sewing needle and matching sewing thread. Don't iron the label on — you can ruin all your work with one blast of heat.

It's especially important to include care information if you're giving the piece to someone as a gift. Even though you may know how to care for it, the recipient probably doesn't have a clue. If it's not practical to attach a label directly to the item, then a decorative card with the instructions would work just as well. You don't have to go into great detail, just a simple phrase would do. Here are some ideas to help you word the instructions:

- ✔ "I'm delicate. Please hand wash me and lay me flat to dry."
- ✔ "I can be washed and dried."
- ✔ "Take me to the cleaners — I need it."

## Forget Dishpan Hands. Get Afghan Hands!

Hand washing your crocheted items is the safest bet. Unless the yarn specifically states “dry clean only,” this is what I recommend. Here’s how:

**1. Grab a bottle of mild detergent and make sure your sink or bathtub is clean.**

The best soap to use is a mild laundry detergent formulated for delicate items or baby clothes, such as Woolite or Ivory Soap. For small items, the kitchen sink is the perfect size. For larger items such as afghans, the bathtub or washtub works better.

**2. Fill the sink or tub with enough cool to warm water so the item can be submerged.**

**3. Swish the item around gently.**

By keeping the agitation to a minimum, you preserve the integrity of the stitches.

**4. After washing, rinse thoroughly and squeeze out excess moisture.**

Rinse the item under cool water until it runs clear.

Never wring a crocheted item because the twisting motion can stretch the stitches and ultimately ruin the item’s shape.

**5. Wrap the item in towels to absorb the extra moisture and lay flat to dry, blocking as necessary (see the next section for blocking info).**

Never hang a crocheted piece to dry (it will stretch out of shape beyond recognition), and please, keep items out of the sun, which can cause fading.



## Blocking for a Better Shape

If you’re an experienced seamstress or crafter, when you see the word *blocking*, you probably want to run the other direction. If you’re new to the term, I’m not talking about defensive sports moves or the movements of actors on stage. *Blocking* often involves lots of starch, straight pins, and room to lay out your design, and this is true when blocking thread crochet. Although blocking can be a complicated process in some cases, items you craft with yarn can be whipped into shape rather easily.

Blocking can be as simple as the following four steps:

**1. Wet the item until it is saturated, squeezing out excess moisture if necessary.**

**2. Lay it flat, using an absorbent towel underneath to soak up moisture.**

Make sure to lay the piece away from sunlight and direct sources of heat.

**3. Shape it.**

**4. Leave it to dry.**

If your item looks a bit out of whack and isn’t really dirty, check the yarn care instructions, then go ahead and block it. Items that may require blocking include any garments, including hats that sometimes need to be reshaped, and thread crochet items such as doilies and table runners. But keep in mind that any crocheted piece that looks a bit out of shape can usually, but not always, be fixed by blocking.

Blocking a piece made of thread crochet involves a few more steps:

1. **Hand wash the design gently in cold water with mild soap, rinsing several times to remove all the soap residue.**
2. **In a separate clean tub, prepare a liquid starch solution according to the directions on the bottle based on the desired amount of stiffness for the finished piece.**
3. **Immerse the crocheted piece in the solution and allow the solution to completely penetrate the fabric.**
4. **Prepare a blocking surface large enough to accommodate the design, such as a plastic-wrapped piece of cardboard or foam board.**
5. **Remove the item from the solution and blot it dry with a clean towel to remove any extra solution.**
6. **Using rustproof straight pins, pin the design onto the blocking board to the required dimensions, taking care to shape any stitch patterns.**
7. **Blot the design again to remove any excess solution that may still remain.**
8. **Allow the piece to dry completely before removing the pins.**

## *Take It to the Cleaners*

This may be the easiest way of all to clean your crochet (but it may not be the cheapest). If the yarn label says “Dry clean only,” then by all means, take the item to the cleaners. A word of advice, though: Bring the label (or a copy of the label) to the cleaners with you. That way they’ll know what material they’re working with and can use the appropriate chemicals.

## *Get a Load of This: Machine Washing*

In some cases, it’s perfectly fine to throw your crocheted masterpieces in the washing machine. This holds true for items made from synthetic yarns, such as acrylic, which won’t sustain so much damage from the washing machine. Use the delicate cycle and, if size permits, throw the item into a mesh laundry bag. Be sure to check the yarn label for the correct water temperature settings.



It’s always a safe bet to wash these items alone the first time around, just to make sure the colors won’t bleed into the rest of your laundry. If you’re not sure what the correct water temperature should be, opt for the safe route and use the cool water setting.

## *Let It Go for a Spin: Machine Drying*

Sometimes tossing your afghan, scarf, or other piece of handiwork in the dryer is just fine. Again, check the yarn label to make sure it’s okay. Most synthetic yarns will take a low heat setting unless it’s got some funky stuff attached like sequins or mirrors. Add some smooth-textured items like pillowcases to the dryer to help absorb moisture.



Don't machine dry wool — it will shrink! Find a spot large enough to accommodate the piece and lay it out flat, shape it if necessary, and allow to dry, preferably in a place that is out of direct sunlight and won't be disturbed by playful pets.

## *Iron It — but Only If You Must*

If you feel that you need to add some heat to an item to get all the wrinkles out, set the iron on the lowest heat setting suggested for the yarn. Place a slightly damp cloth, such as a clean cotton dish towel, on top of your crocheted piece before ironing.



Never allow the iron to come into direct contact with the yarn. Excessive heat can ruin the integrity of the yarn fibers, and even cotton thread can flatten out too much and ruin the original look of the design.

## *Put Those Hangers Away!*

By all means, use and enjoy your crochet. That's why you made it. But when you're not using the item, whether it's a sweater or tablecloth or anything in between, never, ever, ever hang crocheted items. Hanging stretches out the stitches, and the damage can't be reversed.

- ✓ **For garments, find a spot to lay them flat with as few folds as possible.** If this means you have to rearrange your closet or drawers, go ahead and do it.
- ✓ **For items such as tablecloths, doilies, runners, and even afghans, roll them up and store them that way to minimize creases and folds.**

You've put in a lot of crochet time, so take the time to care for your pieces properly.

## *Dazzling Displays and Safe Storage*

Home décor items are meant to be shown off, so go ahead and use them. If it's a table runner, then lay it out on the table. Afghans can be draped over the back of your favorite chair or sofa, but be sure to keep them out of direct sunlight or extreme temperatures.

If items are to be stored for any length of time, such as holiday designs or winter sweaters, invest in some acid-free tissue paper. Place the paper between the folds and around the outside of the piece. This ensures that the piece stays clean and dust free, and helps preserve the yarn fibers until you bring it out again.



Always put your items away clean. Time in storage allows stains to set, and you may not be able to get them out a year later.

To avoid pulling out pieces that the moths have dined on (especially wool items), place these items in a plastic storage bin with a couple of cedar blocks and store the bin in a cool, dry place.

## Get Rid of Those Pesky Pills

It's inevitable — where there's yarn there's *pills*, those unsightly little balls that pop up on fabric after laundering or from normal wear and tear. Removing the pills can revitalize your crocheted pieces and make them look like new again.

You can get rid of pills two ways:

- ✔ **By using a sweater stone:** This is the recommended preference because it is gentler on the fabric and you have more control over it.
- ✔ **By using a sweater shaver:** These devices are typically battery operated or electric, and if you don't use them properly, you can put holes in your item.

To use a sweater stone properly:

1. **Lay the item on a flat surface.**
2. **Hold the stone in the palm of your hand and gently brush the fabric in smooth short strokes.**

The stone will crumble a bit, but don't worry, this is normal and won't damage your piece. Gently shake the item or use a lint roller to remove these tiny pieces.



Never, ever try to remove pilling with scissors! Remember that crochet is a series of interlocking loops, and if you inadvertently slip and cut even one of the strands of yarn, your whole piece can unravel.

## Chapter 17

# Ten Kid-Friendly Projects

### *In This Chapter*

- ▶ Easy designs kids can crochet
- ▶ Making fun wearables for preteens through teens

**T**his chapter is all about getting the younger set involved. Crochet is hot, and if you can get the kids involved, you just may be starting them on the road to a lifelong affair with a hook and some yarn. If they show an interest, and their motor skills are fairly well developed, no age is too young to start. I started at about 8 years old and got my daughter crocheting when she was about 9. Your kids should be able to read so they can follow a pattern themselves.

The designs featured here are all about giving novice crocheters the opportunity to create something fairly quickly, using basic stitches and techniques. I collaborated with my daughter (who's 11 going on 21!) to come up with many of these designs, from the idea itself to color and stitch choices. You can use this chapter to teach crocheting basics to anyone you know who's old enough to handle a hook and yarn. Browse through the pages, pick a project, and get crocheting.

## *Blue Note Scarf*

Accessories are in, and scarves are no exception. This one is really long and skinny, so you can wrap it around and around your neck or style it any way you choose. It's a perfect design to practice making single crochet stitches. The yarn used is lightly textured and *self-stripping*, which means you end up with a cool, funky design without changing colors. Because of the nature of the yarn, each scarf has a slightly different pattern, each one unique (see Figure 17-1).



**Figure 17-1:**

The self-stripping blue note scarf may not be wide, but it's long — nearly 7 feet long.

## Materials and vital statistics

- ✓ **Yarn:** Bernat “Super Stripes” bulky-weight yarn (97% acrylic/3% polyester), Article #161069 (3.5 oz. [100 g], 182 yds [166 m] each skein): 1 skein of #69742 B & Blue
- ✓ **Hook:** Crochet hook size H-8 U.S. or size needed to obtain gauge
- ✓ **Measurements:** 3 in. wide x 83 in. long
- ✓ **Gauge:** 12 sc = 4 in.; 3 rows = 1 in.
- ✓ **Stitches used:** Chain stitch (ch), single crochet (sc)

This scarf is worked lengthwise in long rows, instead of side to side in shorter rows. You crochet a really long foundation chain, then work just nine more rows, and you’re done.

## Directions

**Foundation chain:** Ch 251.

**Row 1:** Sc in 2nd ch from hook, sc in each ch across (250 sc), *turn*.

**Rows 2–9:** Ch 1, sc in each sc across (250 sc), *turn*. Fasten off.

## Wear Your Heart Pin

This pin is super-easy and fast to make (see Figure 17-2). It’s one of those designs that you can sit down and make several of them in an evening — then hand out to your friends the next day. The heart is made using wool yarn and some simple increasing and decreasing to get the shape. Throw it in the washer and dryer to *felt* (make the yarn fibers mat together and shrink), then sew on the pin back. Pin it to a jacket, hat, or even your backpack. It’s a fun and versatile accessory.



**Figure 17-2:**  
This felted heart pin is so easy that you can make one for all your friends.



## Materials and vital statistics

- ✓ **Yarn:** Lion Brand “Lion Wool” worsted-weight yarn (100% wool), Article #820 (3 oz. [85 g], 158 yds [144 m] each skein): 1 skein of #113 Scarlet makes many
- ✓ **Hook:** Crochet hook size H-8 U.S. or size needed to obtain gauge
- ✓ **Pin back**
- ✓ **Sewing needle and matching sewing thread**
- ✓ **Measurements:** 4 in. wide x 4½ in. long before felting. Heart will shrink during felting process. The one shown here measured ¾ in. wide x about 4 in. long after felting.
- ✓ **Gauge:** 14 sts = 4 in; 16 rows = 4 in.
- ✓ **Stitches used:** Chain stitch (ch), single crochet (sc). **Dec 1 sc:** • (Insert hook in next st, yo, draw yarn through st) twice, yo, draw yarn through 3 loops on hook •. **Dec 2 sc:** • (Insert hook in next st, yo, draw yarn through st) 3 times, yo, draw yarn through 4 loops on hook •.

This is a great project to crochet to get comfortable with shaping a piece using both increasing and decreasing. You start off with just one single crochet stitch at the base of the heart, then gradually increase your stitches until the project reaches the desired width. Each side of the top of the heart is crocheted separately, and they are created by decreasing the stitches to form the rounded tops.

## Stitching the heart

**Foundation chain:** Ch 2.

**Row 1 (right side):** Sc in 2nd ch from hook (1 sc), *turn*.

**Row 2:** Ch 1, 2 sc in sc (2 sc), *turn*.

**Row 3:** Ch 1, 2 sc in each sc across (4 sc), *turn*.

**Row 4:** Ch 1, 2 sc in first sc, sc in each of next 2 sc, 2 sc in last sc (6 sc), *turn*.

**Row 5:** Ch 1, sc in each sc across (6 sc), *turn*.

**Row 6:** Ch 1, 2 sc in first sc, sc in each of next 4 sc, 2 sc in last sc (8 sc), *turn*.

**Row 7:** Ch 1, sc in each sc across (8 sc), *turn*.

**Row 8:** Ch 1, 2 sc in first sc, sc in each of next 6 sc, 2 sc in last sc (10 sc), *turn*.

**Row 9:** Ch 1, sc in each sc across (10 sc), *turn*.

**Row 10:** Ch 1, 2 sc in first sc, sc in each of next 8 sc, 2 sc in last sc (12 sc), *turn*.

**Row 11:** Ch 1, sc in each sc across (12 sc), *turn*.

**Row 12:** Ch 1, 2 sc in first sc, sc in each of next 10 sc, 2 sc in last sc (14 sc), *turn*.

**Row 13:** Ch 1, sc in each sc across (14 sc), *turn*.

***Beg shaping***

**Row 14:** Ch 1, sc in each of first 7 sc (7 sc), *turn*, leaving rem sts unworked.

**Row 15:** Ch 1, dec 1 sc in first 2 sc, sc in each sc across (6 sc), *turn*.

**Row 16:** Ch 1, sc in each of first 4 sc, dec 1 sc in last 2 sc (5 sc), *turn*.

**Row 17:** Ch 1, dec 1 sc in first 2 sc, sc in each sc across (4 sc), *turn*.

**Row 18:** Ch 1, sc in each sc across (4 sc), *turn*.

**Row 19:** Ch 1, dec 1 sc in first 2 sc, sc in each of last 2 sc (3 sc), *turn*.

**Row 20:** Ch 1, dec 2 sc in last 3 sc (1 sc). Fasten off.

***Shape second side***

**Row 1:** With right side facing, join yarn in first st of Row 13, ch 1, sc in each of first 7 sc (7 sc), *turn*.

**Rows 2–7:** Rep Rows 15–20.

***Fusing the stitches and finishing***

*Felting* is what happens to wool fibers when they're exposed to hot water and friction. The stitches fuse into a densely woven fabric that is extremely durable but still soft to the touch. Additionally, the fabric shrinks during this process. The amount of shrinkage that occurs varies according to the amount of agitation and the heat of the water, so no two pieces come out exactly the same.

Start by putting the piece in the washing machine with the appropriate amount of detergent for the size of the load you are running, and use the hot or warm wash/cool rinse cycle. Because this piece is so small, you can throw it in with other items. Just make sure they can be washed in hot water and are of like colors (a few towels work well) because the dye in the yarn may run. The yarn shouldn't shed, but you never know, so don't throw any good items in with this at first.

It's a good idea to check your piece periodically (about half way through, then again before the end of the cycle) to make sure it's not felting too much. (To check the piece, stop the washer and wait for everything to stop moving before you reach into the machine.) If, at the end of the complete wash cycle, you want a more felted look, just run the piece through again.

You can also felt it even more in the dryer. Put the item in the dryer on the regular setting, and run the dryer until the piece is almost dry. While it's still damp, lay it flat, adjust into the proper shape, and allow the piece to finish air drying. If your piece is felted to your satisfaction when it comes out of the washing machine, you can let it air dry completely. Lay the piece on a flat surface and shape to dry.



Don't forget to check the piece during the felting process. After the fibers are fused, you can't undo it.

***Assembly***

When the piece is dry, using the sewing needle and thread, sew the pin back to the center back of the heart.

## MP3 Player Cover

Everyone seems to have an MP3 player today, and I have to say, it sure makes it easy to take your music with you. To reduce the risk of scratching the player, it's a good idea to protect it with a cover. Why buy one when you can make your own? This design gives you a stylish way to protect your music and show off your skills (see Figure 17-3). Plus, there's a pocket built right in where you can store your earphones when you're not using them.

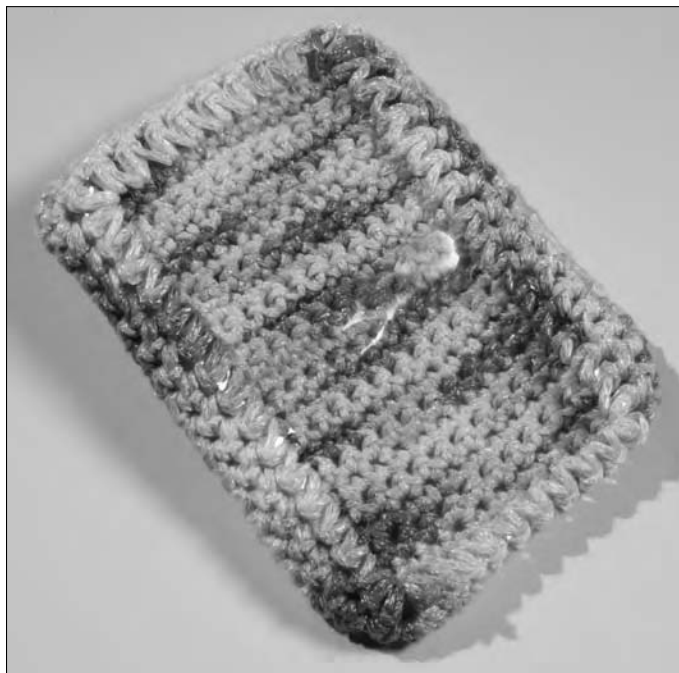

**Figure 17-3:**  
Carry your  
music in  
style.

### *Materials and vital statistics*

- ✓ **Yarn:** Bernat “Cool Crochet” light-weight yarn (70% cotton/30% nylon), Article #161074 (1.75 oz. [50 g], 200 yds [183 m] each skein): 1 skein of #74009 Neopolitan Shades
- ✓ **Hook:** Crochet hook size G-6 U.S. or size needed to obtain gauge
- ✓ **3/16 in. hole punch**
- ✓ **2½ x 4 in. piece of 16-gauge clear vinyl**
- ✓ **Stitch marker**
- ✓ **Tapestry needle**
- ✓ **Measurements:** 3 in. wide x 4 in. long
- ✓ **Gauge:** 11 sts and 11 rows = 2 in.
- ✓ **Stitches used:** Slip stitch (sl st), single crochet (sc)

To crochet this cover, you start by working your initial round of stitches right into the holes you punch in the vinyl cover, instead of creating a foundation chain. You work several rounds to create a border around the front, then begin to work in rows to crochet the back and the pocket. When you've completed all the crocheting, you then sew the back to the front to finish the cover.



## Directions

Working into the holes in the vinyl window is easy — just pretend it's a stitch. Insert your hook through the hole, and it acts the like row below. Just don't pull too tight or you'll pucker the plastic.

### Front vinyl window

Using the template shown in Figure 17-4, cut vinyl to match. With  $\frac{3}{16}$  hole punch, punch holes  $\frac{1}{4}$  in. in from edge according to template.

### Front window border

**Rnd 1 (right side):** Join yarn in top left-hand corner hole of vinyl, ch 1, • 3 sc in corner hole, sc in each hole across to next corner •, rep from • to • around (52 sc), *do not join*. Continue to work in a spiral, marking beg of each row, moving marker up as work progresses.

**Rnd 2:** Sc in next sc, • 3 sc in next sc (corner), sc in each sc across to next corner •, rep from • to • twice, 3 sc in next sc (corner), sc in each sc around (60 sc). Work now progresses in rows.

**Row 3:** Sc in each of next 21 sc (21 sc), *turn*, leaving rem sts unworked.

**Row 4:** Ch 1, sc in each of first 49 sc (49 sc), *turn*.

**Row 5:** Ch 1, sc in each of first 31 sc (31), *turn*, leaving rem sts unworked.

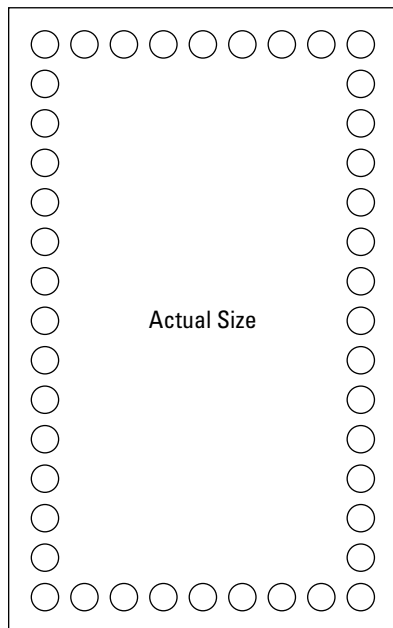

**Figure 17-4:**  
Template  
for front  
cover —  
actual size.

### Beq back

**Row 1 (wrong side):** Ch 1, sc in each of first 13 sc (13 sc), *turn*, leaving rem sts unworked.

**Rows 2–10:** Ch 1, sc in each sc across (13 sc), *turn*.

***Beq pocket lining***

**Row 1 (wrong side):** Ch 1, working in flps of sts, sc in each sc across (13 sc), *turn*.

**Rows 2–12:** Ch 1, working in both loops of sts, sc in each sc across (13 sc), *turn*.  
Fasten off.

***Beq pocket front***

**Row 1:** With right side facing, join yarn in rem loop of first st in Row 10 of back, ch 1, sc in rem loop of each sc across (13 sc), *turn*.

**Rows 2–12:** Ch 1, sc in each sc across (13 sc), *turn*. Fasten off.

***Assembly***

With right sides facing, fold the back up toward the top of the front. With tapestry needle and 18-in. length of yarn, matching sts across sides, working through sides and pocket, sew sides of body together. Turn right side out.

## ***Beadies Can-Cozy***

Use this neat little beadies can-cozy (see Figure 17-5) to keep those sweating soft-drink cans from slipping out of your hand and to help keep them cold. Yarn may seem like an odd choice to use for a can-cozy, but it works. The yarn used in this project makes it look like you've got your own designer, beaded cozy. If you don't want to use the cozy to slip onto a can, it also makes a great pencil holder!

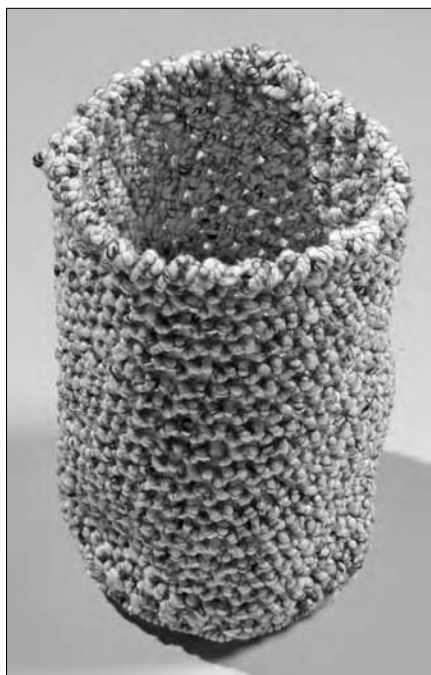

**Figure 17-5:**  
A can-cozy  
keeps your  
drinks cool  
and your  
hands dry.

## Materials and vital statistics

- ✓ **Yarn:** Aunt Lydia's "Beadies Crochet" worsted-weight yarn (94% acrylic/6% polyester), Article #159 (1.76 oz. [50 g], 66 yds [60 m] each skein): 1 skein of #35 Flower Power
- ✓ **Hook:** Crochet hook size J-10 U.S. or size needed to obtain gauge
- ✓ **Stitch marker**
- ✓ **Measurements:** 2¾ in. in diameter x 4½ in. tall
- ✓ **Gauge:** First 4 rnds of bottom = 2 in. in diameter
- ✓ **Stitches used:** Chain stitch (ch), slip stitch (sl st), single crochet (sc), reverse single crochet

To make this can-cozy, you start with a flat base, then work in a spiral to create a tube to slip your can into. Working in a spiral is easy — all you do is work in rounds, but instead of joining each round, you start the next round when you reach the end of the current round, thus eliminating seams.

## Directions

The bottom of the can cozy is flat. To crochet this, you start with a small circle, then increase your stitches in each subsequent round until the proper dimension is reached.

### Bottom

**Center ring:** Ch 4 and close into a ring with one sl st in first ch.

**Rnd 1:** Ch 1, work 6 sc in ring (6 sc), sl st in first sc to join.

**Rnd 2:** Ch 1, 2 sc in each sc around (12 sc), sl st in first sc to join.

**Rnd 3:** Ch 1, sc in first sc, 2 sc in next sc, • sc in next sc, 2 sc in next sc •, rep from • to • around (18 sc), sl st in first sc to join.

**Rnd 4:** Ch 1, sc in each of first 2 sc, 2 sc in next sc, • sc in each of next 2 sc, 2 sc in next sc •, rep from • to • around (24 sc), sl st in first sc to join.

**Rnd 5:** Ch 1, sc in each of first 3 sc, 2 sc in next sc, • sc in each of next 3 sc, 2 sc in next sc •, rep from • to • around (30 sc), sl st in first sc to join.

### Beg sides

**Rnd 1:** Ch 1, working in blps of sts, sc in each sc around (30 sc), *do not join*. Continue to work in a spiral, marking beg of each rnd, moving marker up as work progresses.

**Rnd 2:** Sc in each sc around (30 sc).

Rep Rnd 2 until sides measure 4 in. from beg, sl st in next sc to join at end of last rnd.

**Edging**

Ch 1, working from left to right, reverse sc in each sc around (30 reverse sc), sl st in first reverse sc to join. Fasten off.

**Page Runner**

Okay, so “page runner” is just a fancy name for a bookmark, but this project looks like a runner you’d see on the floor in the hallway (see Figure 17-6). Simple stitches with some fringe added at the ends make for a unique look. These quick designs would be great projects for the school book fair or to sell at a fund-raiser.

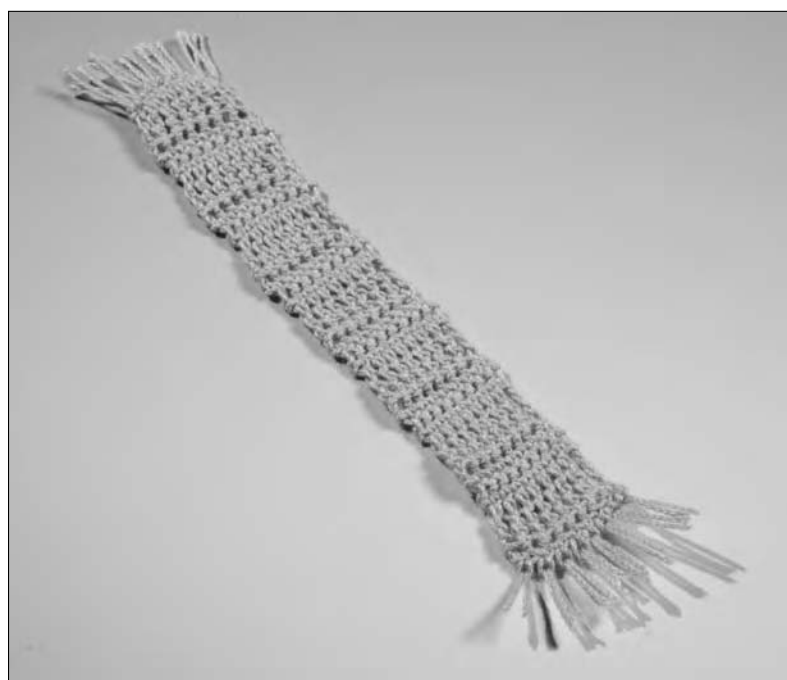

**Figure 17-6:**

The page runner bookmark takes some simple stitches and adds a few pieces of fringe for a touch of flair.

**Materials and vital statistics**

- ✓ **Yarn:** Coats & Clark “LusterSheen” sport-weight yarn (100% acrylic), Article #E721 (4 oz. [113 g], 335 yds [306 m] each skein): 1 skein of #0518 Light Mulberry makes many
- ✓ **Hook:** Crochet hook size F-5 U.S. or size needed to obtain gauge
- ✓ **Measurements:** 1½ in. wide x 8¾ in. long
- ✓ **Gauge:** 5 sts = 1 in.; 4 rows in pat = 1¼ in.
- ✓ **Stitches used:** Chain stitch (ch), single crochet (sc), double triple crochet (dtr) (see Appendix A for details on how to make this stitch)

This project is a great example of a repeating pattern. Four rows are worked over and over again to create the pattern, which is shown in the stitch diagram, Figure 17-7. It's a basic repeat as far as stitch patterns go, and this project is a wonderful opportunity to introduce stitch diagrams to a beginning crocheter.

## Directions

**Foundation chain:** Ch 9.

**Row 1 (wrong side):** Sc in 2nd ch from hook, sc in each ch across (8 sc), *turn*.

**Row 2:** Ch 5 (first dtr), dtr in each sc across (8 dtr), *turn*.

**Rows 3–5:** Ch 1, sc in each st across (8 sc), *turn*.

**Rows 6–25:** Rep Rows 2-5 (5 times).

**Row 26:** Rep Row 2.

**Row 27:** Ch 1, sc in each dtr across (8 sc). Fasten off.

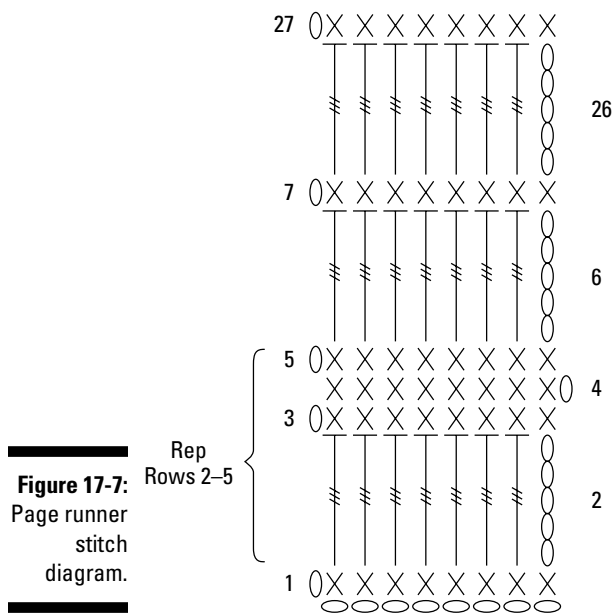

**Finishing:** To make the fringe, cut yarn into 16 4-in. lengths. Using 1 strand of yarn for each fringe, single-knot one fringe in each stitch across each short edge of bookmark. Trim ends even.

## Camouflage Belt

I dare you to try and find a preteen, tween, or teen who doesn't have at least one camouflage item in her wardrobe. Even adults are wearing it. This belt (see Figure 17-8) is perfect for adding a touch of camouflage to your outfit. If your favorite camouflage pants or that great camo T-shirt is still in the laundry, throw this belt on with a pair of jeans. Simple stitches and a D-ring belt buckle are all it takes to create this great fashion accessory.





**Figure 17-8:**  
Wear cam-  
ouflage at  
your waist  
for a trendy  
look.

## *Materials and vital statistics*

- ✓ **Size:** Directions given are for size X-Small. Changes for Small, Medium, Large, X-Large, and XX-Large are in parentheses. Finished waist: 34 (36, 38, 40, 42, 44) in.
- ✓ **Yarn:** Coats & Clark Red Heart “Super Saver” worsted-weight yarn (100% acrylic), Article #E300 (5 oz. [141 g], 255 yds [233 m] each skein): 1 skein of #0971 Camouflage
- ✓ **Hook:** Crochet hook size H-8 U.S. or size needed to obtain gauge
- ✓ **Belt buckle:** Gold-colored D-ring style buckle
- ✓ **Tapestry needle**
- ✓ **Measurement:** 1½ in. wide
- ✓ **Gauge:** 4 sts in pat = 1 in.; 14 rows in pat = 4 in.
- ✓ **Stitches used:** Chain stitch (ch), single crochet (sc)

Crocheting doesn’t get a whole lot easier than this. This project uses a basic stitch pattern that’s really versatile, and it creates a flexible fabric without being too bulky — ideal for around your waist. The single crochet stitches are worked into the chain spaces of the previous row, and the chain spaces are created over the single crochet stitches, which alternate in each row.

## *Directions*

**Foundation chain:** Ch 8.

**Row 1 (right side):** Sc in 2nd ch from hook, • ch 1, skip next ch, sc in next ch •, rep from • to • across (4 sc and 3 ch-1 spaces), *turn*.

**Row 2:** Ch 1, sc in first sc, • sc in next ch-1 space, ch 1, skip next sc •, rep from • to • across to within last ch-1 space, sc in last ch-1 space, sc in last sc (5 sc and 2 ch-1 spaces), *turn*.

**Row 3:** Ch 1, sc in first sc, • ch 1, skip next sc, sc in next ch-1 space •, rep from • to • across to within last 2 sc, ch 1, skip next sc, sc in last sc (4 sc and 3 ch-1 spaces), *turn*.

Rep Rows 2–3 for pat until belt measures 39 (41, 43, 45, 47, 49) in. from beg or to desired length. Fasten off.

**Assembly:** With wrong side facing, draw Foundation row through flat side of both belt rings and fold over, matching Foundation row to Row 10. With tapestry needle and yarn, sew Foundation row to Row 10, matching sts across and enclosing belt rings.

## Chocolate Lace Headband

The design for this lace headband (see Figure 17-9) not only provides a great hair accessory, but also gives you the opportunity to practice a simple yet common stitch pattern. Brown seems to be the color of choice these days, but as always, you can choose another color (or several others) to suit your taste.



**Figure 17-9:** You achieve the lacy look of this headband by using a larger hook with the yarn.

## Materials and vital statistics

- ✓ **Yarn:** Bernat “Cool Crochet” light-weight yarn (70% cotton/30% nylon), Article #161074 (1.75 oz. [50 g], 200 yds [183 m] each skein): 1 skein of #74013 Chocolate makes several
- ✓ **Hook:** Crochet hook size H-8 U.S. or size needed to obtain gauge
- ✓ **Tapestry needle**
- ✓ **Measurements:** 2 in. wide x 16 in. in circumference
- ✓ **Gauge:** 10 sts in pat = 2 in.; 13 rows in pat = 4 in.
- ✓ **Stitches used:** Chain stitch (ch), single crochet (sc), double crochet (dc)

You create this pattern by using a slightly larger hook than is normally used for this yarn, which creates a lacy look to a pattern that is normally tighter and textured. Just crochet a strip, sew together the ends, and you’re done. This project can easily be made in a couple of hours.

## Directions

**Foundation chain:** Ch 11.

**Row 1 (right side):** Sc in 2nd ch from hook, dc in next ch, • sc in next ch, dc in next ch •, rep from • to • across (10 sts), *turn*.

**Row 2:** Ch 1, sc in first dc, dc in next sc, • sc in next dc, dc in next sc •, rep from • to • across (10 sts), *turn*.

Rep Row 2 for pat until piece measures 16 in. from beg. Fasten off, leaving a 10-in. sewing length.

**Assembly:** With right sides facing, using tapestry needle and sewing length, matching sts across short edges, sew last row to foundation ch, thus forming a circle.

## Chain-Link Bracelet

A girl can never have enough accessories, and with this easy pattern, you can make as many bracelets as you can fit on your arms. This design can be crocheted in less than an hour, so you can make dozens in no time at all. This bracelet features three wire chains held together with a jump ring and spring ring clasp (see Figure 17-10), but feel free to branch out on your own. It would look equally as good with just one chain or several, whatever suits your taste.



**Figure 17-10:**  
Crochet  
simple  
chains to  
form a  
bracelet.

## *Materials and vital statistics*

- ✓ **Yarn:** Wyr Knittr Wyr Pak 30 gauge copper-coated wire (40 yds per spool) #02106 Jewels (1 spool each of pink, green, blue per pack)
- ✓ **Hook:** Crochet hook size G-6 U.S. or size needed to obtain gauge
- ✓ **Jump ring and spring ring clasp**
- ✓ **Measurement:** 7 in. in circumference
- ✓ **Gauge:** 17 chain sts = 4 in.
- ✓ **Stitches used:** Chain stitch (ch)

This bracelet is just a bunch of chains, but what makes it unique is the material it's crocheted from. Wire crocheted jewelry is everywhere. But don't be intimidated by the wire — it's almost easier to use than yarn. It tends to be a bit slippery, so you may have to work a little slower, and be sure not to pull your stitches too tight. You want to leave them loose so you can see the individual stitches.

## *Directions*

Make 1 chain each in pink, blue, and green.

**Foundation chain :** Leaving a 3-in. tail, ch 30. Fasten off, leaving a 3-in. tail.

**Assembly:** Lay chains side by side, matching up ends. Twist wire tails together, then insert one end through clasp and the other end through the jump ring. Twist ends tightly to secure. Trim even.

## *Variation: Making matching pieces*

To make a matching necklace, follow the instructions above, but make your chains longer, anywhere from 16 in. to 20 in. or more, whatever length you desire.

To crochet matching earrings, follow the instructions above, but make your chains much shorter, about 10 chain stitches for a small hoop, 12–15 stitches for larger hoops. Attach the wire ends to the earring post of your choice.

## *Think Pink Pocket Purse*

This pocket purse (see Figure 17-11) is the perfect little hold-all for any small items that you don't want to lose in the bottom of your purse or shoulder bag. The hot pink "suede" yarn gives the purse a unique color and feel, so you can look in your bag and see it right away or reach in and grab it by feel.



**Figure 17-11:**  
You can use this little purse to hold change, lip gloss, or other little doodads in your bag.

## *Materials and vital statistics*

- ✓ **Yarn:** Lion Brand “Lion Suede” bulky-weight yarn (100% polyester), Article #210 (3 oz. [85 g], 122 yds [112 m] each skein): 1 skein of #140 Rose
- ✓ **Hook:** Crochet hook size I-9 U.S. or size needed to obtain gauge
- ✓ **Yarn needle**
- ✓ **One 1-in. button**
- ✓ **Sewing needle and matching sewing thread**

- ✓ **Measurements:** 4 in. wide x 3 in. tall
- ✓ **Gauge:** 12 sc in pat = 4 in.; 11 rows in pat = 4 in.
- ✓ **Stitches used:** Chain stitch (ch), single crochet (sc). **Dec 1 sc:** • (Insert hook in next st, yo, draw yarn through st) twice, yo, draw yarn through 3 loops on hook •.

You crochet this pocket purse as one piece, using decreasing stitches to shape the front flap. Then you sew the fabric together at the sides. Add a pretty button to the front for the closure, and you're good to go. This can easily be made in an evening, so make matching pocket purses for all your friends.

## Directions

**Foundation chain:** Ch 13.

**Row 1 (right side):** Sc in 2nd ch from hook, sc in each ch across (12 sc), *turn*.

**Row 2:** Ch 1, sc in flp of first sc, sc in blp of next sc, • sc in flp of next sc, sc in blp of next sc •, rep from • to • across (12 sc), *turn*.

**Row 3:** Ch 1, sc in blp of first sc, sc in flp of next sc, • sc in blp of next sc, sc in flp of next sc •, rep from • to • across (12 sc), *turn*.

Rep Rows 2–3 for pat until piece measures 5¼ in. from beg.

### *Beg front flap*

**Next Row:** Ch 1, dec 1 sc in first 2 sc, maintaining flp/blp pat, sc in each sc across to within last 2 sc, dec 1 sc in last 2 sc (10 sc), *turn*.

Rep last row until 4 sts rem on work.

**Next Row:** Ch 1, sc in first sc, ch 2, skip next 2 sc (buttonhole made), sc in last sc (4 sts), *turn*.

**Next Row:** Ch 1, sc in first sc, 2 sc in ch-2 space, sc in last sc (4 sc), *turn*.

**Next Row:** Ch 1, (dec 1 sc in next 2 sc) twice (2 sc), *turn*.

**Last Row:** Ch 1, dec 1 sc in 2 sc (1 sc). Fasten off.

### *Assembly*

With right sides facing, fold Foundation row up to last row before beginning of the front flap. Using yarn needle and 12-in. length of yarn, sew side seams. With sewing needle and matching sewing thread, sew button to the front aligned with buttonhole.

## Variation: *Stitching a small handbag*

To make a larger bag that is approximately 10 in. wide x 8 in. deep, you need 3 skeins of yarn.

***Beg the bag***

**Foundation chain:** Ch 31.

**Row 1 (right side):** Sc in 2nd ch from hook, sc in each ch across (30 sc), *turn*.

**Row 2:** Ch 1, sc in flp of first sc, sc in blp of next sc, • sc in flp of next sc, sc in blp of next sc •, rep from • to • across (30 sc), *turn*.

**Row 3:** Ch 1, sc in blp of first sc, sc in flp of next sc, • sc in blp of next sc, sc in flp of next sc •, rep from • to • across (30 sc), *turn*.

Rep Rows 2–3 for pat until piece measures 16 in. from beg.

***Beg front flap***

**Next Row:** Ch 1, dec 1 sc in first 2 sc, maintaining flp/blp pat, sc in each sc across to within last 2 sc, dec 1 sc in last 2 sc (28 sc), *turn*.

Rep last row until 4 sts rem on work.

**Next Row:** Ch 1, sc in first sc, ch 2, skip next 2 sc (buttonhole made), sc in last sc (4 sts), *turn*.

**Next Row:** Ch 1, sc in first sc, 2 sc in ch-2 space, sc in last sc (4 sc), *turn*.

**Next Row:** Ch 1, (dec 1 sc in next 2 sc) twice (2 sc), *turn*.

**Last Row:** Ch 1, dec 1 sc in 2 sc (1 sc). Fasten off.

***Assembly***

With right sides facing, fold Foundation row up to last row before beginning of the front flap. Using yarn needle and 18-in. length of yarn, sew side seams. With sewing needle and matching sewing thread, sew button to the front aligned with buttonhole.

***Adding a shoulder strap***

**Row 1:** With right side facing, join yarn in first stitch to the right of side seam on one side of bag, ch 1, sc in st, sc in side seam, sc in next st (3 sc), *turn*.

**Row 2:** Ch 1, sc in each sc across (3 sc), *turn*.

Rep Row 2 until strap reaches desired length.

**Next Row:** With right side facing, being careful not to twist strap, sl st in corresponding st on opposite side of bag, sl st in each of next 2 sts. Fasten off.

## ***Beaded Anklet***

Here's a piece of jewelry that's been around for many years. Anklets can be rather formal, made with gold or silver and jewels, or casual, as this one is. The yarn used is studded with beads, and the color reminds me of the always popular hemp jewelry (see Figure 17-12). Crochet a couple rows, attach a clasp, and fasten around your ankle.



**Figure 17-12:**  
You can  
create  
wearable  
art for  
your ankle.

## Materials and vital statistics

- ✓ **Yarn:** Moda Dea “Beadnik” worsted-weight yarn (90% Acrylic/5% polyester/5%PVC), Article #R149 (1.76 oz. [50 g], 103 yds [94 m] each ball): 1 ball of #2923 Daddy-O Tan makes many
- ✓ **Hook:** Crochet hook size F-5 U.S. or size needed to obtain gauge
- ✓ **Jump ring and spring ring clasp**
- ✓ **Measurements:** ½ in. wide x 9¼ in. long
- ✓ **Gauge:** 17 sts in pat = 4 in.
- ✓ **Stitches used:** Chain stitch (ch), slip stitch (sl st), single crochet (sc). **Bobble:** • 3 dc (half closed and joined tog) worked in same st •. (See Appendix A for details.)

This anklet not only consists of just two rows, which makes it quick and easy to crochet, but also gives you the chance to practice your bobble making.

## Directions

**Foundation chain:** Leaving a 3-in. tail, ch 46.

**Row 1 (right side):** Sc in 2nd ch from hook, bobble in next ch, • sl st in next ch, bobble in next ch •, rep from • to • across to within last ch, sc in last ch (22 bobbles), *turn*.

**Row 2:** Ch 1, sc in first sc, sl st in next bobble, • sc in next sl st, sl st in next bobble •, rep from • to • across to within last sc, sc in last sc. Fasten off, leaving a 3-in. tail.

**Assembly:** Using tails, tie spring clasp to one end of anklet and jump ring to the other end of anklet. Weave in ends.



# Part V

# Appendixes

The 5<sup>th</sup> Wave

By Rich Tennant

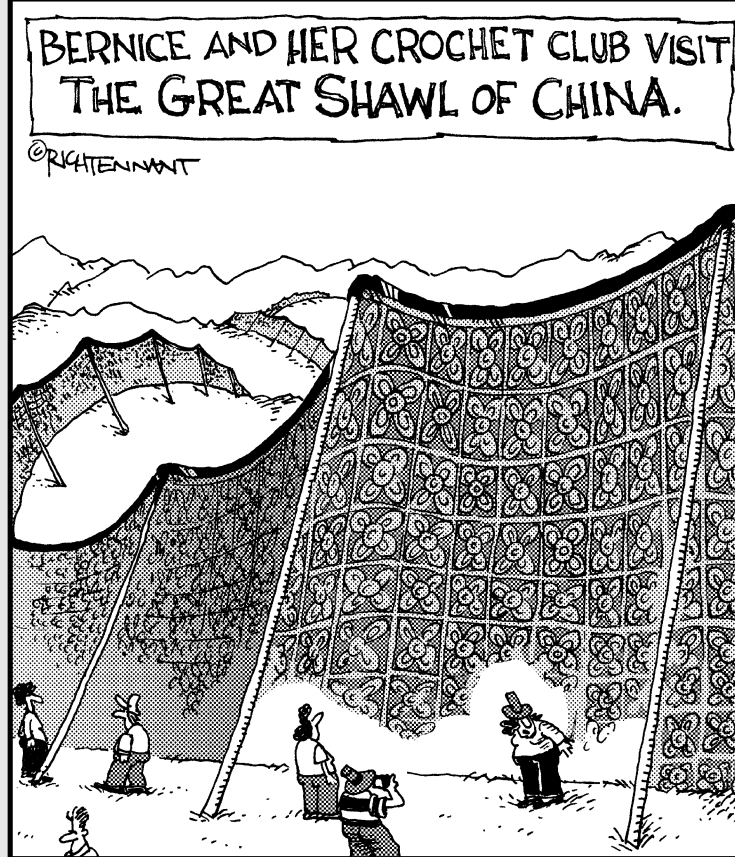

"Wait—don't take the picture yet. My watch is snagged."

## *In this part . . .*

**I**f you're looking for a refresher lesson on how to do a particular stitch, you've come to the right place. Appendix A includes steps for completing basic stitches, more advanced stitches, and finishing techniques.

If, after searching high and low at your local yarn or craft store, you can't find a particular yarn I've recommended in one of the patterns, look at the resource list in Appendix B. Contact information for several yarn companies is listed there.

# Appendix A

## Crochet Stitches

---

**E**ven if you're familiar with how to make most crochet stitches, it never hurts to have a reference. Almost all of the stitches that you'll come across in your day-to-day crocheting can be found here, along with illustrations and step-by-step instructions. The stitches are in relative order beginning with the easiest and moving forward from there. After the basic stitches, you'll find some of the more common stitch combinations, as well as a few miscellaneous items such as sewing techniques and embellishments.

I include a few of the unique or more complex stitches as new skills in the chapters in which they are used. So if you're looking for instructions on how to do one of the following stitches, you need to flip to the chapter indicated:

- ✓ **The loop stitch:** Chapter 11
- ✓ **The afghan stitch:** Chapter 13
- ✓ **The Tunisian knit stitch:** Chapter 13
- ✓ **Filet crochet stitches (spaces, blocks, lacets, and bars):** Chapter 13

### Slipknot

Before you can do anything, you first have to join the yarn to the hook. This is accomplished by making a slipknot.

1. **Starting about 6 inches from the end of the yarn, make a loop that looks somewhat like a pretzel.**
2. **Insert your hook through the center of the loop (see Figure A-1) and draw the working end of the yarn through.**

**Figure A-1:**  
Drawing  
the yarn  
through  
the loop.

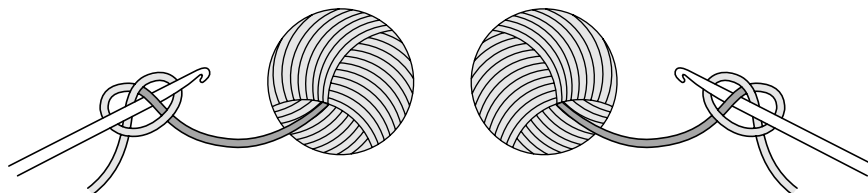

3. **Gently tug on both ends of the yarn to tighten the loop around your hook (see Figure A-2).**

**Figure A-2:**  
Tightening  
the loop  
around  
the hook.

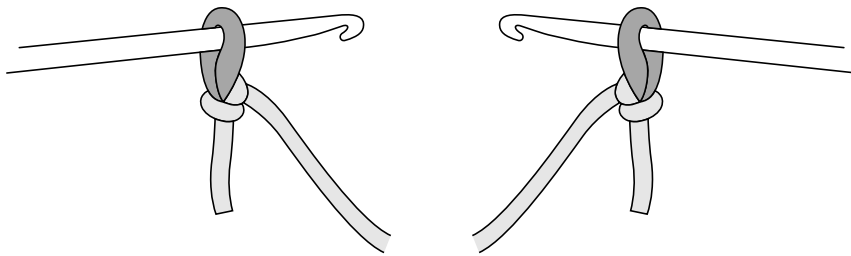

## Chain Stitch (ch)

I can't think of a single crocheted piece that doesn't start with at least one chain stitch. This stitch forms the base that you work all your stitches off of, whether it's a foundation chain or a center ring.

1. Slide a slipknot onto the shaft of your hook.
2. Yarn over (yo) your hook.
3. Draw the yarn through the loop on your hook to make the first chain stitch (see Figure A-3).

**Figure A-3:**  
Making the  
first chain  
stitch.

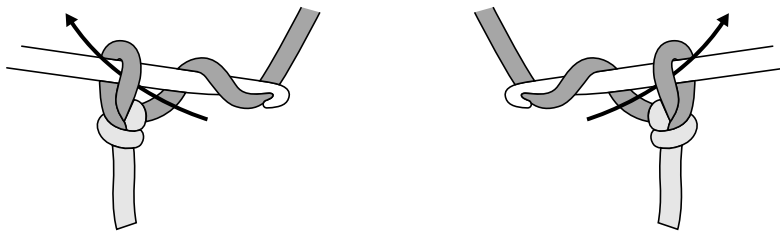

4. Repeat Steps 2 and 3 for the required number of stitches (see Figure A-4), holding the chain close to your hook as it grows for better control.

**Figure A-4:**  
Several  
chain  
stitches  
in a  
row.

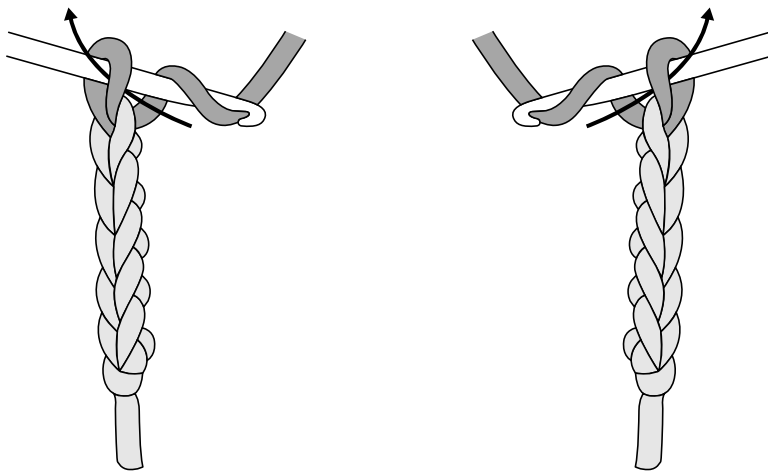

## Slip Stitch (sl st)

This is a handy little stitch that you can use for lots of reasons. It's used for fastening off, traveling from one place to the next when you don't want your stitches visible, joining seams, or creating a nice smooth edge, just to name a few. It has next to no height and lays relatively flat. It's easier to work the slip stitch on an established row, so to practice this stitch, make a swatch using double crochet stitches 16 stitches long and several rows deep.

1. Insert your hook in the next stitch (see Figure A-5).

**Figure A-5:**  
Beginning  
the first  
slip stitch.

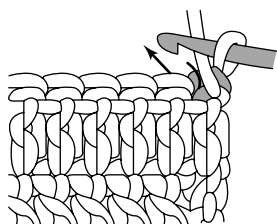

2. Yarn over (yo) your hook.
3. Draw the yarn through the stitch and through the loop on your hook (see Figure A-6).

**Figure A-6:**  
Completing  
the first  
slip stitch.

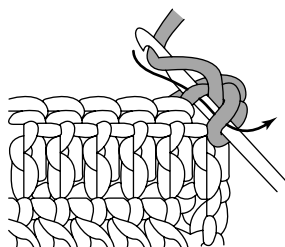

4. Repeat Steps 1 through 3 for the required number of stitches (see Figure A-7).

**Figure A-7:**  
Working the  
slip stitch  
across  
the row.

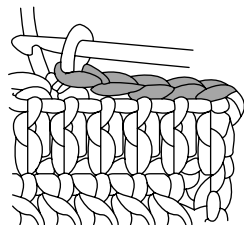

## Single Crochet Stitch (sc)

This stitch is the most elementary of all stitches, and you'll use it a lot. It's compact and creates a nice tight fabric. It's often used alone, but in many cases it works well in combination with other stitches.

1. Insert your hook in the 2nd chain stitch from your hook (see Figure A-8).

**Figure A-8:**  
Starting the first single crochet stitch.

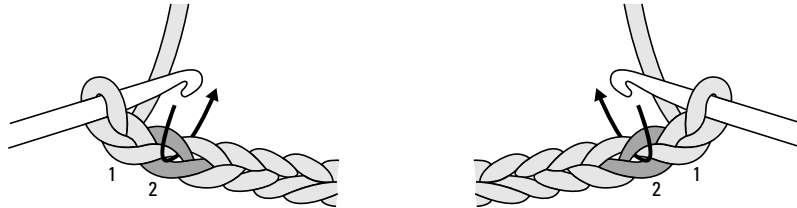

2. Yarn over (yo) your hook, and draw the yarn through the stitch (see Figure A-9).

**Figure A-9:**  
Drawing the yarn through the stitch.

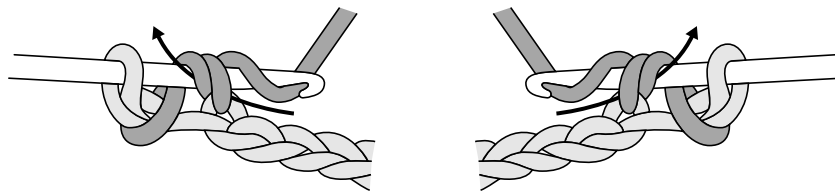

3. Yarn over, and draw the yarn through the 2 loops on your hook (see Figure A-10).

**Figure A-10:**  
Completing the first single crochet stitch.

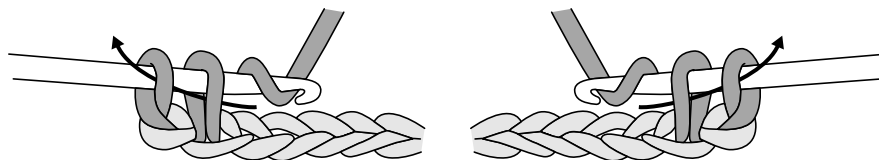

4. Insert your hook in the next stitch, then repeat from Step 2 for the required number of stitches.

## Double Crochet Stitch (dc)

The double crochet stitch is another stitch that you'll use all the time. It's about twice as tall as the single crochet stitch and creates a fairly solid — but not stiff — fabric. It's used alone and in combination with other stitches.

1. Yarn over (yo) your hook, and insert your hook in the 4th chain from your hook (see Figure A-11a).

**Figure A-11:**  
The first two steps in creating a double crochet stitch.

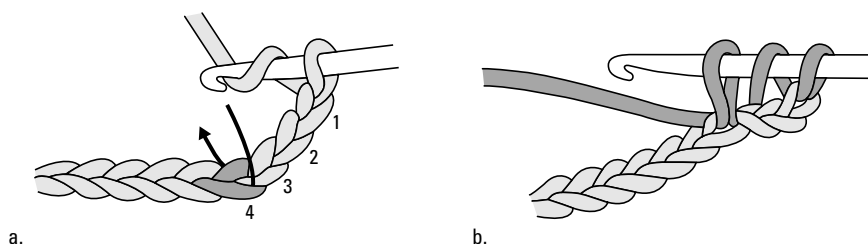

2. Yarn over, and draw the yarn through the stitch (see Figure A-11b).
3. Yarn over, and draw the yarn through 2 loops on your hook (see Figure A-12a).

**Figure A-12:**  
Completing the double crochet stitch.

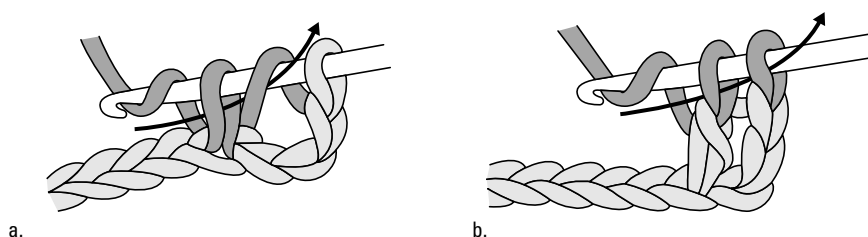

4. Yarn over, and draw the yarn through the remaining 2 loops on your hook (A-12b).
5. Yarn over, and insert your hook in the next stitch, repeating from Step 2 for the required number of stitches.

## Triple Crochet Stitch (*tr*)

The triple crochet stitch is similar to the double crochet but is slightly taller. It creates a loose, open fabric with longer openings between each stitch. You often use the triple crochet in combination with other stitches to create interesting textures and patterns.

1. Yarn over (yo) twice, and insert your hook in the 5th chain from your hook (see Figure A-13a).

**Figure A-13:**  
Starting a triple crochet stitch.

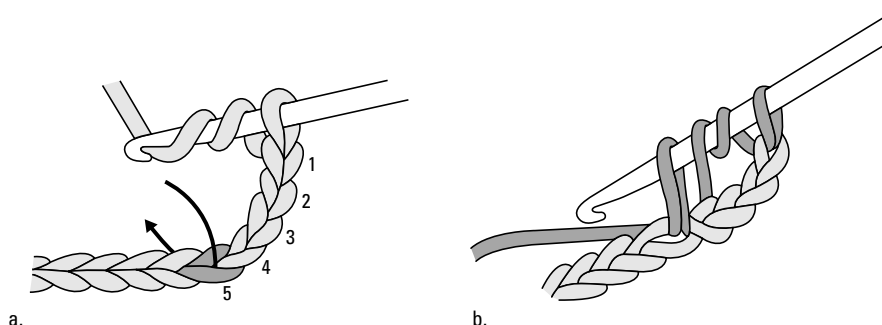

2. Yarn over, and draw the yarn through the stitch (see Figure A-13b).
3. Yarn over, and draw the yarn through 2 loops on your hook (see Figure A-14a).

**Figure A-14:**  
Drawing  
the yarn  
through  
the loops.

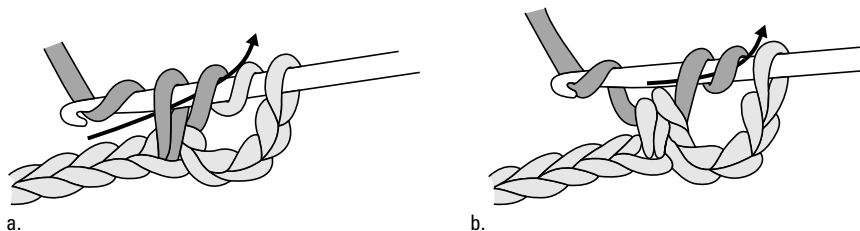

4. Yarn over, and draw the yarn through 2 loops on your hook (see Figure A-14b).
5. Yarn over, and draw the yarn through the last 2 loops on your hook (see Figure A-15a).

One triple crochet stitch is now complete (see Figure A-15b).

**Figure A-15:**  
Completing  
the first  
triple  
crochet.

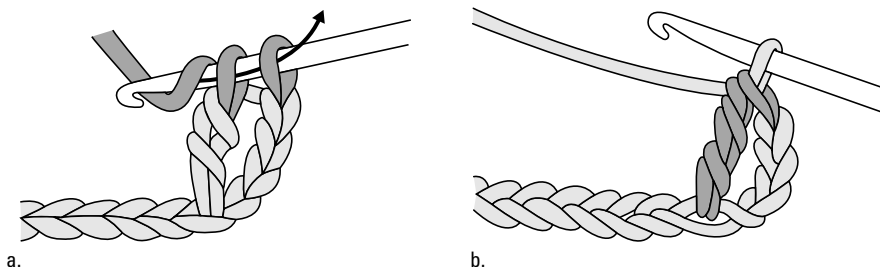

6. Yarn over twice, and insert your hook in the next stitch, repeating from Step 2 for the required number of stitches.

## Double Triple Crochet (dtr)

This stitch is yet again a little bit taller than the triple crochet, and is often used in combinations with other stitches to create a lacy pattern. The fabric itself is loose and holey, and you commonly see it used in thread crochet designs.

1. Yarn over (yo) 3 times, and insert your hook in the next stitch (see Figure A-16).

**Figure A-16:**  
Beginning a  
double triple  
crochet  
stitch.

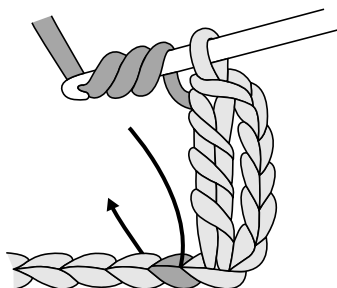



**2. Yarn over, and draw the yarn through the stitch.**

You should now have 5 loops on your hook.

**3. Yarn over, and draw your yarn through the first 2 loops on your hook (4 loops remain).****4. Repeat Step 3 three more times until you have only 1 loop on your hook.**

One double triple crochet stitch is complete (see Figure A-17).

**Figure A-17:**  
Several  
complete  
double triple  
crochet  
stitches.

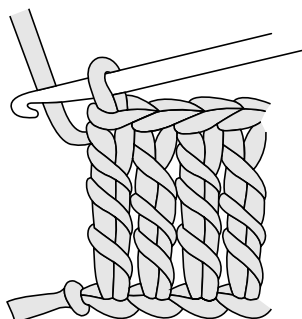

## Half Double Crochet Stitch (hdc)

The half double crochet stitch is a funny kind of in-between stitch. You start out as you would for a double crochet stitch and finish like a single crochet stitch. It's like a fatter version of the single crochet, with a height somewhere between the single and double crochet.

**1. Yarn over (yo), and insert your hook in the 3rd chain from your hook (see Figure A-18a).**

**Figure A-18:**  
Beginning a  
half double  
crochet  
stitch.

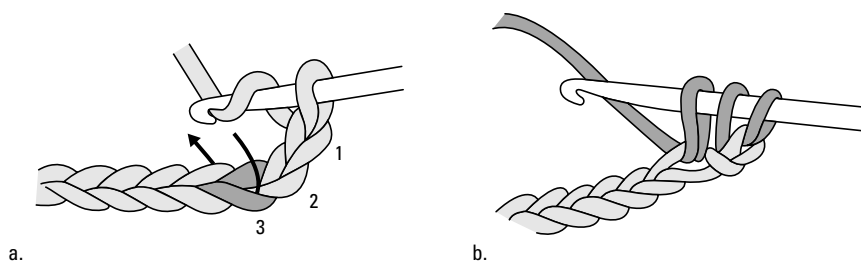
**2. Yarn over, and draw the yarn through the stitch (see Figure A-18b).****3. Yarn over, and draw the yarn through the 3 loops on your hook (see Figure A-19a).**

See Figure A-19b for the finished half double crochet.

**Figure A-19:**  
Finishing a half double crochet stitch.

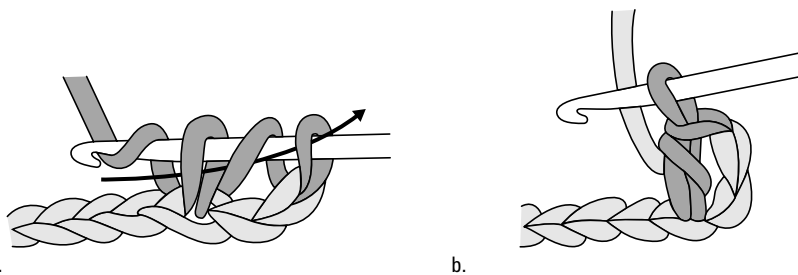

4. Yarn over, insert your hook in the next stitch, repeating from Step 2 for the required number of stitches.

## Decrease 1 Single Crochet Stitch (*dec 1 sc*)

Decreasing stitches is an integral part of crochet. It's not difficult; you just have a few simple steps to follow. To shape any design, whether working in rows or rounds, you need to know how to work this two-part process of turning two stitches into one.

1. Insert your hook into the next stitch.
2. Yarn over (yo), and draw the yarn through the stitch, leaving 2 loops on your hook.
3. With the 2 loops still on your hook, insert your hook into the next stitch (see Figure A-20).

**Figure A-20:**  
Beginning the second half of the single crochet decrease.

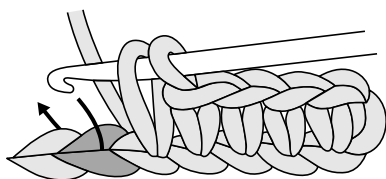

4. Yarn over, and draw the yarn through the stitch.
5. Yarn over, and draw the yarn through all 3 loops on your hook (see Figure A-21a).

You've made one single crochet decrease, as shown in Figure A-21b.

**Figure A-21:**  
Completing a single crochet decrease.

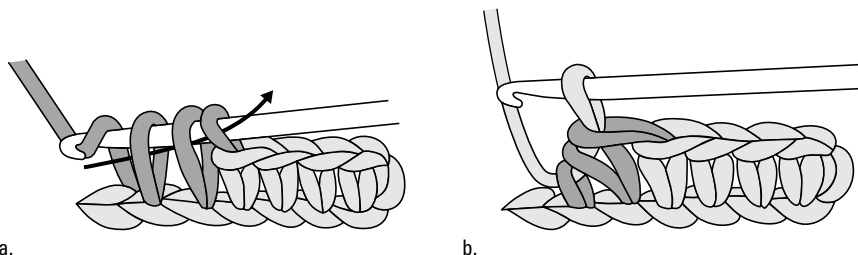

## Decrease 1 Double Crochet Stitch (*dec 1 dc*)

Making a double crochet decrease is second only in frequency of use to the single crochet decrease. It's worked in a similar manner, but because of the extra loops you have an extra step.

1. Yarn over (yo), and insert your hook into the next stitch.
2. Yarn over, and draw the yarn through the stitch.
3. Yarn over, and draw the yarn through the first 2 loops on the hook (see Figure A-22).

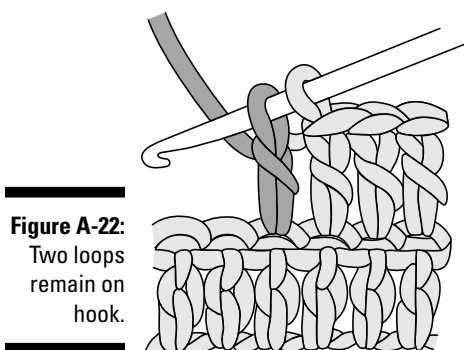

4. With 2 loops still on your hook, yarn over, and insert your hook into the next stitch (see Figure A-23).

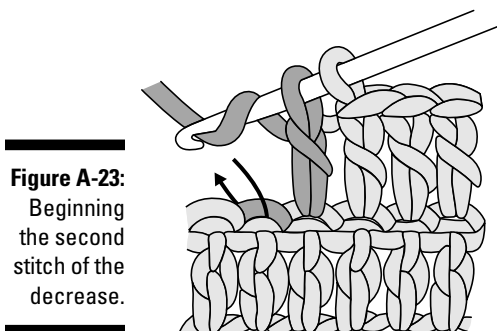

5. Yarn over, and draw the yarn through the stitch.
6. Yarn over, and draw the yarn through the first 2 loops on the hook (3 loops remain).
7. Yarn over, and draw the yarn through all 3 loops on the hook (see Figure A-24a).

One double crochet decrease is now complete (see Figure A-24b).

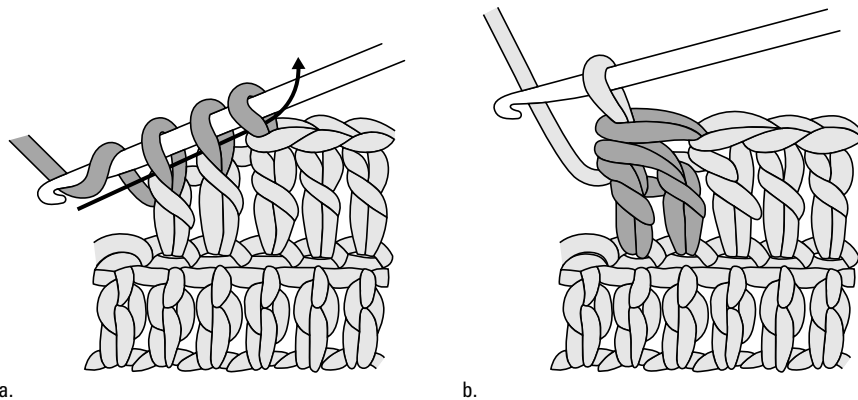
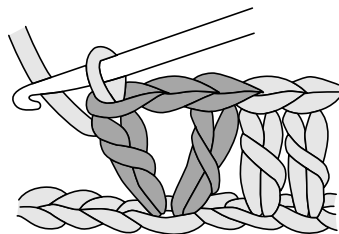

**Figure A-24:**  
Finishing up  
a double  
crochet  
decrease.

## V-stitch

The V-stitch is an extremely easy and versatile stitch combination. It's typically comprised of two double crochet stitches and a chain stitch worked together all in the same stitch with the results forming a V.

**Work 1 double crochet stitch, chain 1, then work another double crochet stitch (dc, ch1, dc) all in the same stitch (see Figure A-25).**



**Figure A-25:**  
Creating a  
V-stitch.

## Crossed Double Crochet Stitch

To create this pattern that looks like a bunch of X's marching across your fabric, you work two double crochet stitches on an angle. That's not as hard as it may sound — you simply skip stitches so you're not working in the stitch directly below.

1. Skip the next stitch in the row.
2. Work 1 double crochet in the next stitch.
3. Working behind the double crochet stitch you just made, work 1 double crochet into the skipped stitch (see Figure A-26a).

Figure A-26b shows the completed crossed double crochet stitch.

4. Repeat Steps 1 through 3 for the required number of stitches.

**Figure A-26:**  
Working a  
crossed  
double  
crochet  
stitch.

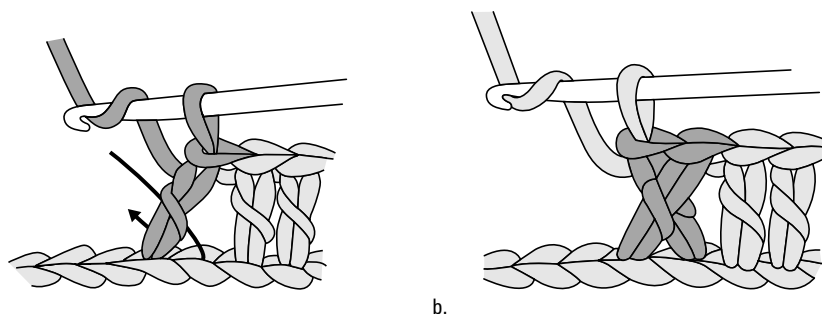

## Shell Stitch

This is another one of those stitch combinations that you'll see everywhere. The shape of the shell stitch resembles a clam shell, and the stitch can be used to create either a very tight fabric, or when worked in combination with other stitches, a loose and airy pattern. The illustration here shows a shell made with four double crochet stitches, but variations of the stitch can use any number.

**Work 4 double crochet stitches all in the same stitch, as shown in Figure A-27.**

**Figure A-27:**  
Crocheting  
a 4-double  
crochet  
shell stitch.

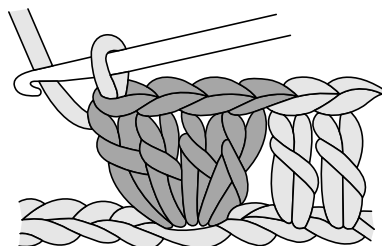

## Picot

These pretty little knobs add a decorative touch to edgings and are often used to fill in an empty space. The picot stitch is most often seen in thread crochet, but there's no reason why it can't be worked with yarn as well.

1. Chain 3.
2. Insert your hook into the third chain from the hook (see Figure A-28a).

**Figure A-28:**  
Crocheting  
a picot  
stitch.

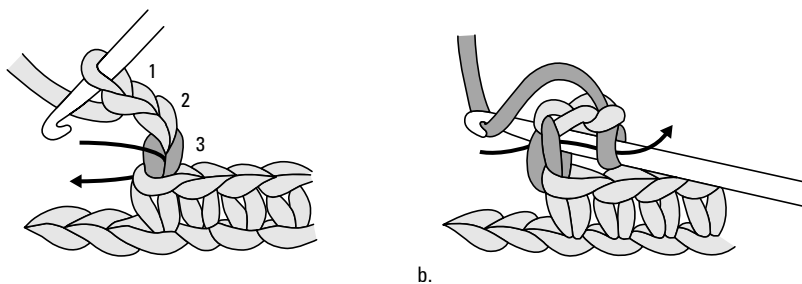

3. Yarn over (yo), and draw the yarn through the stitch and through the loop on the hook (see Figure A-28b).

One picot stitch is now complete, as shown in Figure A-29.

**Figure A-29:**  
The finished  
picot stitch.

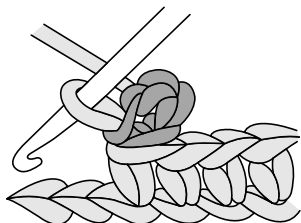

## Cluster Stitch

The cluster stitch is the opposite of the shell stitch, forming a shape that resembles an upside-down shell stitch or a triangle. To create a cluster, you work a set of stitches across an equal number stitches, then join them all together at the top. The technique is the same as a decrease; you're just working a few more stitches than two. When joining several stitches together at the top like this, and you don't complete each stitch until you're done, the stitches are referred to as *half-closed* because you haven't completed them yet. The following example details how to make a cluster of four double crochet stitches.

1. Yarn over (yo), insert the hook into the next stitch, yarn over, draw the yarn through the stitch, yarn over, and draw the yarn through 2 loops on the hook (2 loops remain on the hook).
2. Repeat Step 1 three times (see Figure A-30a).

**Figure A-30:**  
The first  
steps for  
working a  
4-double  
crochet  
cluster  
stitch.

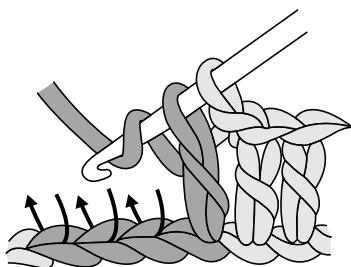

a.

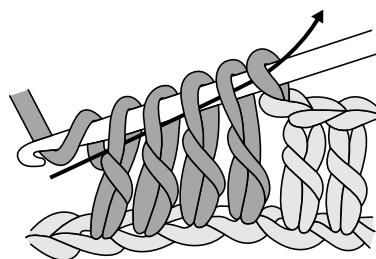

b.

3. Yarn over, and draw the yarn through all 5 loops on the hook (see Figure A-30b).

One 4-double crochet cluster stitch is complete, as shown in Figure A-31.

**Figure A-31:**  
A complete  
4-double  
crochet  
cluster  
stitch.

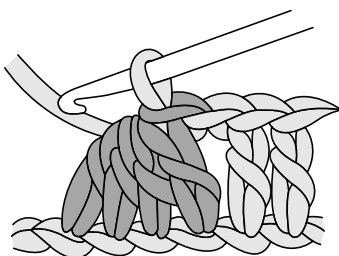

## Reverse Single Crochet Stitch (reverse sc)

The reverse single crochet stitch, sometimes referred to as the crab stitch, creates a rounded twisted edge and is used only to make a finished edging for your piece. You'll never see it in the middle of your work. The mechanics are the same as for a single crochet stitch, except you work in reverse. Instead of working from right to left, you work from left to right.

1. With the right side of your work facing, insert the hook, from the front to the back, in the next stitch to the right (see Figure A-32a).

**Figure A-32:**  
The first  
steps to  
working a  
reverse  
single  
crochet  
stitch.

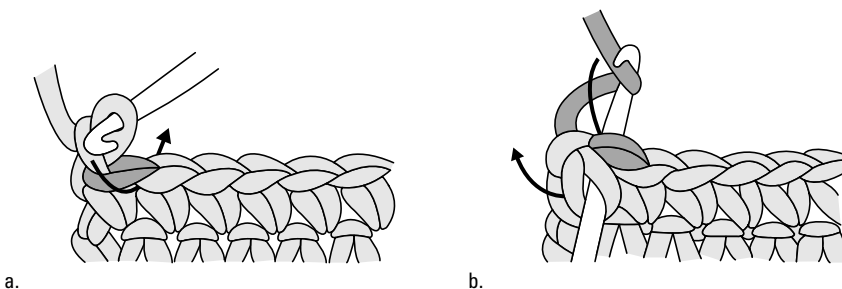

2. Yarn over (yo), and draw the yarn through the stitch (see Figure A-32b).
3. Yarn over, and draw the yarn through the 2 loops on the hook (see Figure A-33a).

**Figure A-33:**  
Finishing a  
reverse  
single  
crochet  
stitch

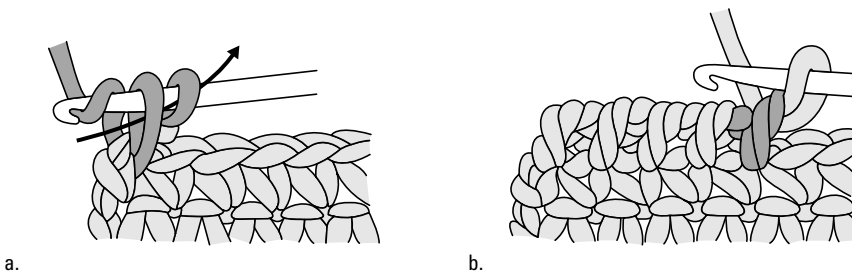

4. Repeat Steps 1 through 3 for the required number of stitches.

Figure A-33b shows several completed reverse single crochet stitches.

## Puff Stitch

This is one of the stitches in the family of oval combination stitches that gently puffs to create texture. The puff stitch is similar to the cluster stitch in construction — you combine several half-closed stitches together. The difference here is that the stitches are all worked in the same stitch as opposed to being worked across several stitches. To create a 3–double crochet puff stitch, follow these steps:

1. **Yarn over (yo), insert the hook in the designated stitch, yarn over, draw the yarn through the stitch, yarn over, and draw the yarn through the 2 loops on the hook (see Figure A-34a).**

**Figure A-34:**  
Working a  
3–double  
crochet  
puff stitch.

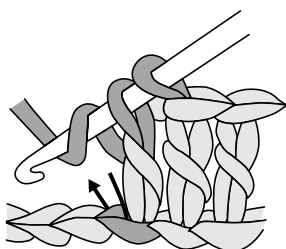

a.

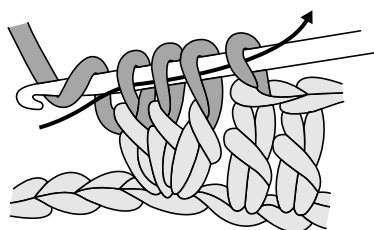

b.

2. **In the same stitch, repeat Step 1 twice.**

You should now have 4 loops on your hook.

3. **Yarn over, and draw the yarn through all 4 loops on your hook, as shown in Figure A-34b.**

Figure A-35 shows the completed 3–double crochet puff stitch.

**Figure A-35:**  
The  
completed  
puff stitch.

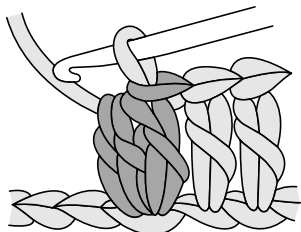

## Popcorn Stitch (pop or pc)

The popcorn stitch is the second stitch in the family of ovals. This one really stands out from the fabric — it's a rounded, compact oval that you can make so it “pops” either to the front of your work or the back. It takes a little more time to make this stitch, but the results are well worth it.

To make a popcorn stitch that pops to the front of your work, follow these steps:

1. **Work 5 double crochet stitches in the same stitch.**
2. **Drop the loop from your hook.**



3. Insert your hook from front to back under the top 2 loops of the first double crochet of the group.
4. Grab the dropped loop with your hook and pull it through the stitch (refer to Figure A-36a).

Figure A-36b shows the finished popcorn stitch popping to the front.

**Figure A-36:**  
Making a  
front-  
popping  
popcorn  
stitch.

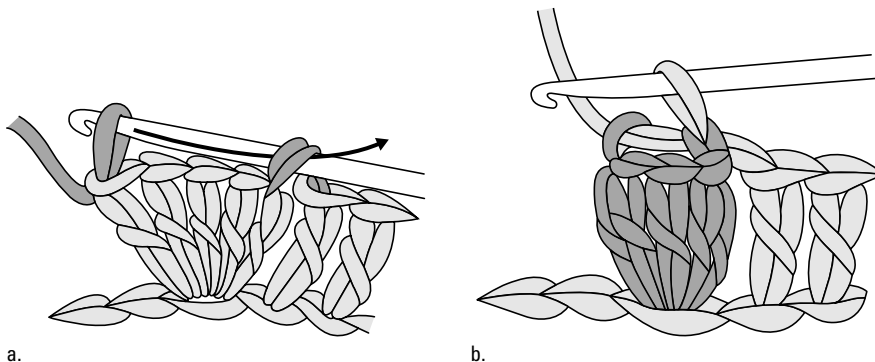

To make a popcorn stitch “pop” to the back of your work:

1. Work 5 double crochet stitches in the same stitch.
2. Drop the loop from your hook.
3. Insert your hook from back to front under the top 2 loops of the first double crochet of the group.
4. Grab the dropped loop with your hook and pull it through the stitch (refer to Figure A-37a).

Figure A-37b shows the finished popcorn stitch popping to the back of your work.

**Figure A-37:**  
Making a  
back-  
popping  
popcorn  
stitch.

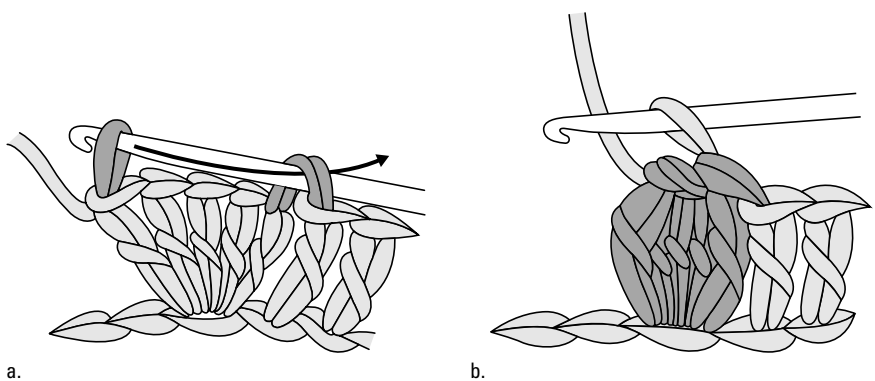

## Bobble Stitch

This is the last in the family of oval stitches. The bobble stitch is worked a bit differently from the others in that it's made using a series of loops rather than stitches. It creates a smoother surface and is best worked with heavier-weight yarns. These steps show you how to make a bobble stitch that ends up with 11 loops on the hook, but as always, there are variations, so be sure to read the special stitch instructions given at the beginning of each pattern.

1. Yarn over (yo), and insert the hook into the designated stitch (see Figure A-38a).

**Figure A-38:**  
The beginning stages of the bobble stitch.

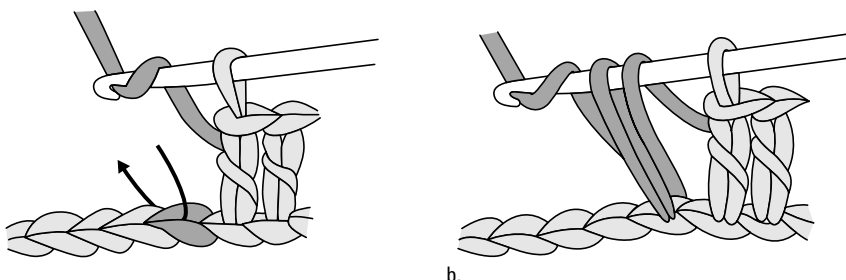

2. Yarn over, and draw the yarn through the stitch, bringing the loop up to the height of the previous stitch (3 loops on hook — see Figure A-38b).
3. Working in the same stitch, repeat Steps 1 and 2 four times (11 loops on hook).
4. Yarn over, and draw the yarn through all 11 loops on hook as shown in Figure A-39a.

One bobble stitch is complete (see Figure A-39b).

**Figure A-39:**  
Wrapping up the bobble stitch.

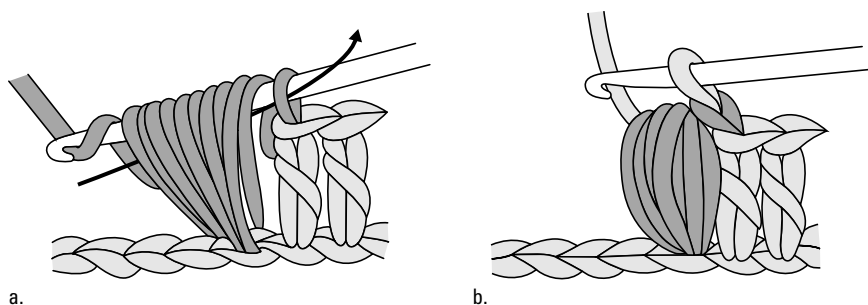

## Front Post Double Crochet (FPdc)

Sometimes you don't work stitches into the tops of the stitches in the previous row, but rather you find another place to stick your hook. The front post double crochet stitch is one of those instances. The stitch itself is a plain old double crochet stitch,

but instead of working it in the top of a stitch, you work it around the *post* (or body) of the stitch in the previous row. This causes the stitch to stand out and is used to create cable patterns, ribbing, and others relief designs.

1. Yarn over (yo), and insert your hook from front to back between the posts of the first and second double crochet of the row below and then from back to front again between the posts of the second and third stitches (see Figure A-40a).

Figure A-40b shows the correct positioning of the hook.

**Figure A-40:**  
Correct way  
to insert  
your hook  
when work-  
ing a front  
post double  
crochet  
stitch.

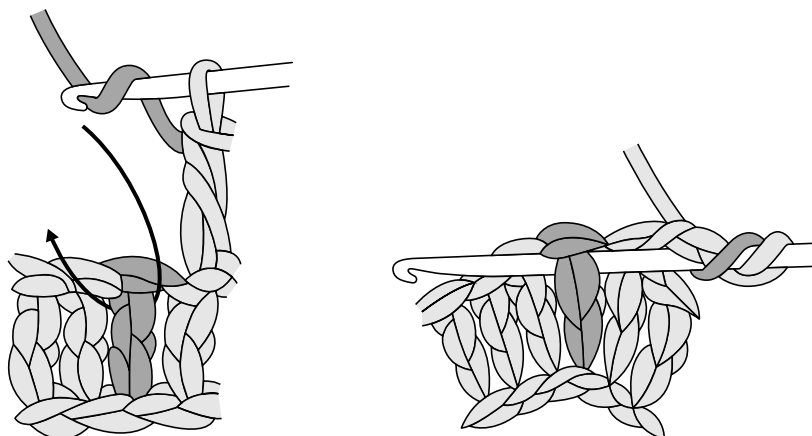

a.

b.

2. Yarn over, and draw the yarn around the post of the stitch.
3. Yarn over, and draw the yarn through the 2 loops on the hook, twice, as shown in Figure A-41a.

Figure A-41b shows the completed front post double crochet.

**Figure A-41:**  
Finishing  
up a front  
post double  
crochet  
stitch.

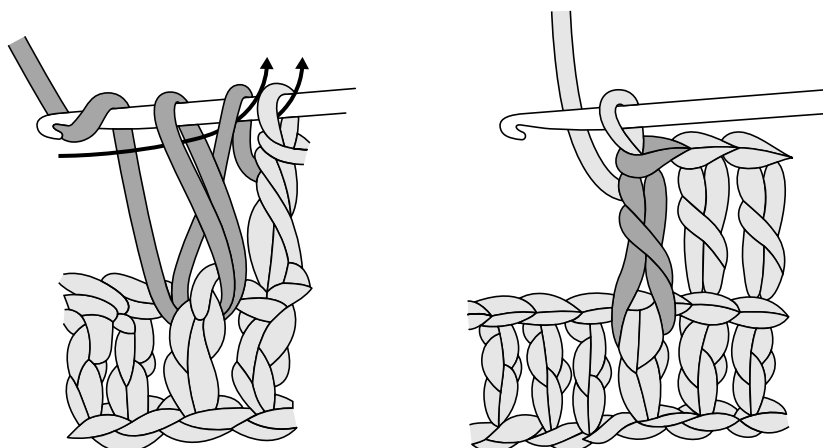

a.

b.

## Back Post Double Crochet Stitch (BPdc)

The back post double crochet stitch looks exactly the same as the front post double crochet, but it's raised to the back side of the fabric. When looking at it from the right side, it appears to recede.

1. Yarn over (yo), and insert your hook from back to front between the posts of the first and second double crochet of the row below and then from front to back again between the posts of the second and third stitches (see Figure A-42a).

Figure A-42b shows the correct positioning of the hook.

**Figure A-42:**  
Correct way  
to insert  
your hook  
when work-  
ing a back  
post double  
crochet  
stitch.

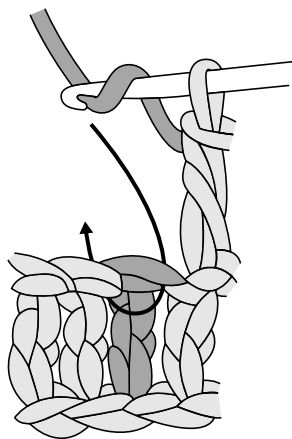

a.



b.

2. Yarn over, and draw the yarn around the post of the stitch.
3. Yarn over, and draw the yarn through the 2 loops on the hook, twice, as shown in Figure A-43a.

Figure A-43b shows the completed back post double crochet.

**Figure A-43:**  
Finishing  
up a back  
post double  
crochet  
stitch.

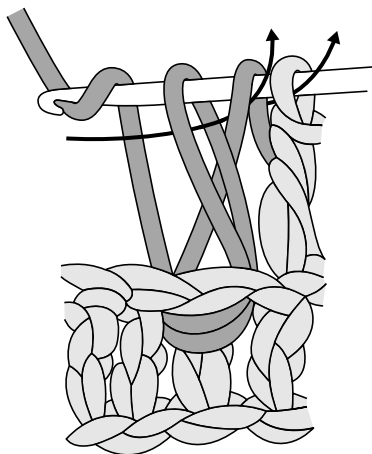

a.

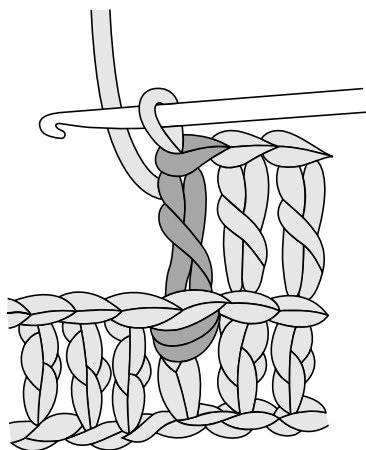

b.

## Long (Spike) Stitch

Long stitches, or spikes as they're sometimes called, are stitches that you work into spaces or stitches two or more rows below the current row you're working on. Typically, they're single crochet stitches, and they create a long vertical spike of yarn on both sides of the fabric. This is especially nice if you're working on a project that's reversible. When done in a contrasting color, they really stand out.

1. Insert the hook from front to back under the top 2 loops of the designated stitch one or more rows below (see Figure A-44).

**Figure A-44:**  
Working a  
long single  
crochet  
stitch three  
rows below.

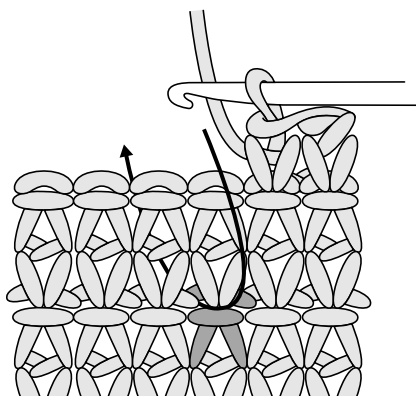

2. Draw the yarn through the stitch and up to the current level of work, keeping the stitch loose enough so it doesn't pucker the fabric.
3. Yarn over (yo), and draw the yarn through the 2 loops on your hook.

One long stitch is complete, as shown in Figure A-45.

**Figure A-45:**  
Completed  
long stitch  
in single  
crochet.

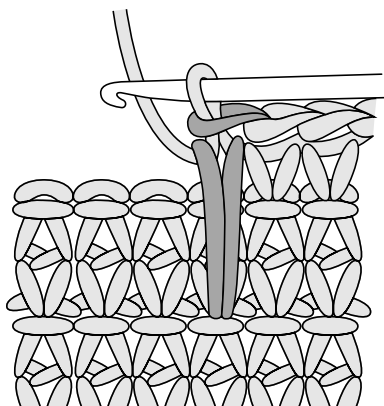

## Fringe

There are times when a pattern just doesn't look complete without the addition of a little extra something across the edges. A nice full fringe usually does the trick, and it also hides row ends, which aren't always so pretty.

1. Cut the yarn into the required number of equal lengths.
2. Fold the strands of yarn for one fringe in half, forming a loop at one end and matching the cut ends of the yarn on the other end.
3. Working from the right side of the fabric, take your hook and draw the loop through the stitch that you're attaching the fringe to (see Figure A-46a).

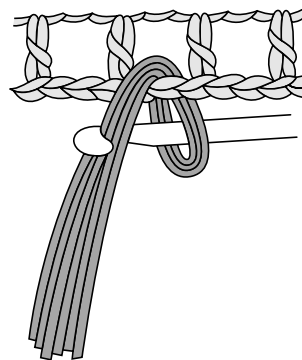
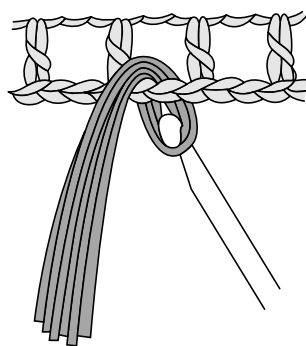

**Figure A-46:**  
The first steps used to make a single-knot fringe.

a.

b.

4. Draw the loose ends of the yarn through the loop (see Figure A-46b).
5. Holding the top of the fringe in one hand, gently pull on the fringe ends with your other hand to tighten the knot.
6. To finish, trim the ends of the fringe so they're even.

Figure A-47 shows a completed single-knot fringe.

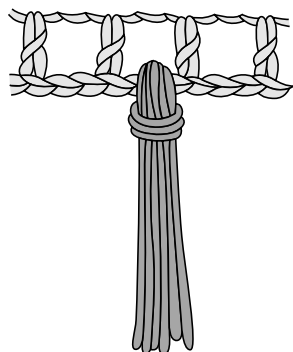
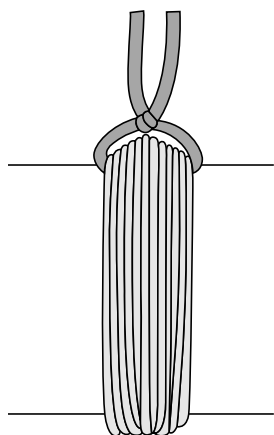

**Figure A-47:**  
The completed fringe attached to a crocheted row.

## Tassels

Tassels add a decorative touch to particular spots on a design, such as the top of a hat or the points of a shawl. Instead of working them directly onto the crocheted piece, you make tassels separately and then attach them to the specified points.

1. Cut a piece of cardboard the same width as your desired tassel length.
2. Wrap the yarn several times around the cardboard.
3. Slip a separate length of yarn between the cardboard and the wrapped yarn, and tie the yarn bundle together at one end (see Figure A-48).



**Figure A-48:**  
Wrapping  
the tassel.

4. Slide the bundle of yarn off the cardboard.
5. Wrap another length of yarn 2 or 3 times around the bundle below the tied end and tie in a knot to secure (see Figure A-49).
6. Cut the loops on the opposite end of the bundle from the tied end.
7. Trim the ends of the tassel so they're even.
8. Using the top tie's remaining yarn length, attach the tassel to the designated spot.

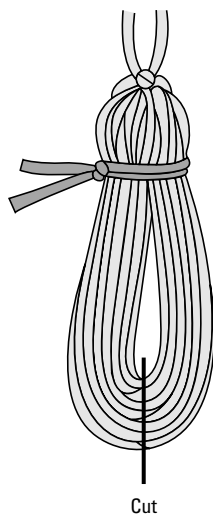

**Figure A-49:**  
Finishing  
steps to  
making a  
tassel.

## Whipstitch

Whipstitch is the all-purpose stitch that's used when sewing project pieces together, such as side seams, shoulder seams, and motifs. It works best with the shorter crochet stitches — single crochet, half double crochet, and double crochet. Sometimes you sew the row-end stitches together, and sometimes you join the tops of stitches. Either way, the key to sewing a successful seam is to match up the stitches on each side of the seam, making sure not to pull too tightly.

1. **Position the pieces with the right sides (or wrong sides, depending on what the pattern says) facing each other. Match the stitches across each side edge.**
2. **Using a yarn needle and matching yarn, weave the yarn back and forth through several stitches on one of the pieces to secure the end.**
3. **Insert the needle and pull the yarn through the inside loops of the first 2 corresponding stitches of the 2 pieces to be joined.**
4. **Draw the needle up and over the 2 loops of the first stitch.**
5. **Repeat Steps 3 and 4 across the edges to be joined (see Figure A-50).**
6. **At the end of the seam, weave the yarn back through several stitches to secure.**

**Figure A-50:**  
Sewing  
a seam  
using the  
whipstitch.

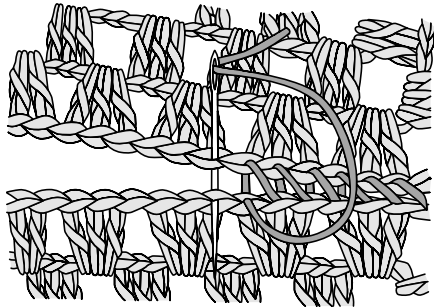

## Blanket Stitch

This is another stitch used to join seams, particularly longer stitches like the triple crochet and taller. When sewing seams with this stitch, you always join the row-end stitches at the top and the base, which adds stability and helps to prevent gaping.

1. **With the correct sides facing each other (right side/wrong side, depending on the pattern), lay the pieces of fabric on a flat, smooth surface and align the edges and stitches.**
2. **Using a yarn needle and matching yarn, thread the yarn through the base of the first few corresponding stitches, leaving a yarn length to weave in later to secure the seam.**
3. **Lay the working end of the yarn against the fabric in the direction of the stitches, as shown in Figure A-51.**



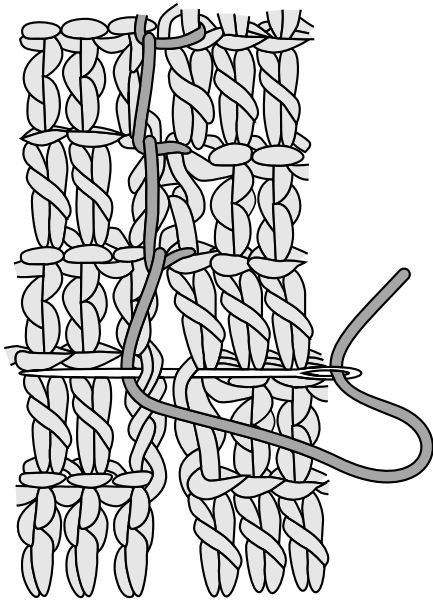

**Figure A-51:**  
Joined at  
the hip with  
the blanket  
stitch.

4. Thread your yarn through the base of the next 2 corresponding stitches, making sure that the working end of the yarn is underneath the needle.
5. Repeat Steps 3 and 4 across the edges to be joined.
6. At the end of the seam, weave the yarn back through several stitches to secure.



## Appendix B

# Yarn Supply Sources



**M**ost of the yarns and notions used for the projects in this book can be easily found at your local craft store or yarn shop. If you're unable to find a particular yarn, or they're unavailable in your area, you can contact the following manufacturers directly. Most have Web sites that you can order from, or if not, they can direct you to a retailer.

- ✓ **Bernat Yarns:** 320 Livingstone Ave. South, Listowel, ON, Canada N4W 3H3; 888-368-8401; [www.bernat.com](http://www.bernat.com)
- ✓ **Caron International:** Customer Service, P.O. Box 222, Washington, NC 27889; [www.caron.com](http://www.caron.com)
- ✓ **Coats & Clark Inc.:** Consumer Services, P.O. Box 12229, Greenville, SC 29612-0229; 800-648-1479; [www.coatsandclark.com](http://www.coatsandclark.com)
- ✓ **DMC Corporation:** 77 S. Hackensack Ave., Bldg 10F, South Kearny, NJ 07032-4688; 973-589-0606; [www.dmc-usa.com](http://www.dmc-usa.com)
- ✓ **Herrschners:** 2800 Hoover Road, Stevens Point, WI 54492-0001; 800-441-0838; [www.herrschners.com](http://www.herrschners.com)
- ✓ **Lily Sugar n Cream:** 320 Livingstone Ave. South, Listowel, ON, Canada N4W 3H3; 888-368-8401; [www.sugarncream.com](http://www.sugarncream.com)
- ✓ **Lion Brand Yarn:** 135 Kero Road, Carlstadt, NJ 07072; 800-258-YARN (800-258-9276); [www.lionbrand.com](http://www.lionbrand.com)
- ✓ **Moda Dea:** P.O. Box 12229, Greenville, SC 29612-0229; 800-648-1479; [www.modadea.com](http://www.modadea.com)
- ✓ **Muench Yarns:** 1323 Scott St., Petaluma, CA 94954-1135; 800-733-9276; [www.muenchyarns.com](http://www.muenchyarns.com)
- ✓ **Patons Yarns:** 320 Livingstone Ave. South, Listowel, ON, Canada N4W 3H3; 888-368-8401; [www.patonsyarns.com](http://www.patonsyarns.com)
- ✓ **Plymouth Yarn:** P.O. Box 28, Bristol, PA 19007; 215-788-0459; [www.plymouthyarn.com](http://www.plymouthyarn.com)
- ✓ **Rowan Yarns:** Green Lane Mill, Holmfirth, HD9 2DX England; +44 (0) 1484 681881; [www.knitrowan.com](http://www.knitrowan.com)
- ✓ **Twilley's of Stamford:** Thomas B. Ramsden (Bradford) Limited, Netherfield Road, Guiseley, Leeds, LS20 9PD; (01943) 872264; [www.tbramsden.co.uk](http://www.tbramsden.co.uk)
- ✓ **South West Trading Company:** 866-794-1818; [www.soysilk.com](http://www.soysilk.com)



# Index

## *Symbols and Numerics*

- ( and ) (parentheses) characters, pattern instructions, 35
- [ and ] (brackets) characters, pattern instructions, 36
- \* (asterisk) character, pattern instructions, 34
- (bullet) character, pattern instructions, 34–35
- † (cross) character, pattern instructions, 34
- + (plus sign) character, pattern instructions, 34
- 1 double crochet stitch decrease (dec 1 dc), technique illustrated, 237–238
- 1 single crochet stitch decrease (dec 1 sc), technique illustrated, 236
- 16-gauge clear vinyl, MP3 player cover, 213

## • A •

- abbreviations, pattern instructions, 32–33
- acid-free tissue paper, item storage, 207
- acrylic, synthetic fiber, 13
- adult's rolled-brim hat project, 103–105
- afghan category, medium yarn, 12
- afghan hooks, uses, 8
- afghan stitch baby blanket project, 151–155
- afghans
  - granny square, 171–172
  - home decor display, 207
  - synthetic fibers, 13
  - wavy chevron throw, 90–92
  - wooly warmer, 60–62
- aluminum hooks
  - cleaning, 10
  - pros/cons, 8
- anklet, kid-friendly project, 225–226
- aran yarn category
  - beginners, 15
  - medium yarn, 12
- article number, label information, 13–14
- asterisk (\*) character, pattern instructions, 34

## • B •

- babies, size charts, 28
- baby blanket, afghan stitch, 151–155
- baby category
  - fine yarn, 12
  - super fine yarn, 12
- back hip length, sizing measurements, 25–26
- back post double crochet stitch (BPdc), technique illustrated, 246

- back waist length, sizing measurements, 25
- back, southwest vest, 116
- bags
  - bella drawstring, 82–84
  - carrying yarn across rows, 45
  - gear storage, 18
  - honey, I shrunk my bag, 174–176
  - shaping, 52
  - Tunisian stitch tote, 155–158
- bars, fancy filet crochet stitch, 163–164
- basic filet crochet stitch, love-to-read bookmark, 158–159
- basket, hemp, 176–178
- beaded anklet, kid-friendly project, 225–226
- beaded chain stitch, wire-'n'-beads necklace, 179
- beaded-fringe belt project, 63–66
- beadies can-cozy, kid-friendly project, 215–217
- beading round, flirty denim skirt, 75
- beads
  - beaded-fringe belt, 64
  - flirty denim skirt, 74
  - geometric wrap, 126
  - springtime pullover, 138
  - wire-'n'-beads necklace, 179, 180
- beads-'n'-bows belt project, 98–100
- beginners
  - aran weight yarn, 15
  - H-8 U.S. hook, 15
  - wool/acrylic blends, 13
  - worsted weight yarn, 15
- beginning-of-row
  - adding new yarn, 42–43
  - decreases, 48
  - skipping stitches, 49
- bella drawstring bag project, 82–84
- belt buckle
  - camouflage belt, 219
  - double-crossing belt, 120
- belts
  - beaded-fringe, 63–66
  - beads-'n'-bows, 98–100
  - camouflage, 218–220
  - double-crossing, 119–121
  - flower-power, 111–113
  - southwest vest, 116
- beret, coffee suede, 76–79
- Bernat Yarns, 253
- binders, care instruction storage, 203–204
- blanket stitch, technique illustrated, 250–251

blankets  
 afghan stitch baby blanket, 151–155  
 hiding yarn strands, 45

blends, natural/synthetic fibers, 13

blocking  
 crochet thread pieces, 206  
 gauge swatch, 22  
 love-to-read bookmark, 163  
 techniques, 205–206

blocks  
 basic filet crochet stitch, 158, 160–161  
 fancy filet crochet stitch, 163, 165–166

blue note scarf, kid-friendly project, 209–210

bobble stitch  
 beaded anklet, 226  
 combination stitch, 42  
 technique illustrated, 244

bolero (lacy) project, 133–137

bookmarks  
 chart, 162  
 lacy, 183–185  
 love-to-read bookmark, 158–163  
 page runner, 217–218

borders  
 afghan stitch baby blanket, 155  
 MP3 player cover, 214

bouclé, yarn weight/texture, 12

BPdc. *See* back post double crochet stitch (BPdc)

bracelets  
 chain-link, 221–223  
 friendship bracelet, 190–192

brackets [ and ] characters, pattern instructions, 36

brand name, label information, 13–14

brims  
 adult's rolled-brim hat, 105  
 child's rolled-brim hat, 103

Brittain, Susan (*Crocheting For Dummies*), 3, 4

buckle, belt, 120, 219

bulky category, super bulky yarn, 12

bulky weight, yarn weight/texture, 12

bulky, yarn category, 12

bullet (•) character, pattern instructions, 34–35

bust, sizing measurements, 25

button band, fur-trimmed jacket, 150

buttonhole band, fur-trimmed jacket, 150

buttons  
 fur-trimmed jacket, 146  
 standout luggage tag, 201  
 think pink pocket purse, 223

## • C •

camouflage belt, kid-friendly project, 218–220

Canada, hook sizing conventions, 9–10

can-cozy, kid-friendly project, 215–217

cardboard  
 creating tassels, 249  
 lacy bookmark project, 184  
 used in blocking, 163, 206

care instructions  
 attaching labels to a project, 204  
 label information, 13–14  
 saving old labels, 203–204

Caron International, 253

cases, hook storage, 11

CC (contrasting color), 32, 247

center back/neck-to-cuff, sizing measurements, 25

center rings  
 adult's rolled-brim hat, 104  
 beadies can-cozy, 216  
 child's rolled-brim hat, 102  
 flower-power belt, 112–113  
 hemp basket, 177–178  
 must-see fur frame, 200  
 velvet roses, 193–194  
 working in rounds, 50

ch. *See* chain stitch

chain loops, flower-power belt, 111–112

chain stitch (ch)  
 center ring, 50  
 picot stitch combination, 41  
 standout luggage tags, 201  
 stemmed-glass markers, 198  
 technique illustrated, 230

chain-link bracelet, kid-friendly project, 221–223

charms, stemmed-glass markers, 198

charts  
 garment sizing, 27–29  
 geometric coaster set, 186–188  
 heartland window valance, 167  
 love-to-read bookmark, 162

chenille throw rug, 92–95

chest, sizing measurements, 25

children, size charts, 28

child's rolled-brim hat project, 101–103

chocolate lace headband, kid-friendly project, 220–221

chunky category, bulky yarn, 12

chunky weight, yarn weight/texture, 12

circles, working in rounds, 49–52

clear pouch, project component storage, 18

- clothing. *See also* garments; hats; scarves; shawls  
 care instruction storage, 203–204  
 dry cleaning, 206  
 elegant evening wrap, 117–119  
 flirty denim skirt, 73–76  
 fur-trimmed jacket, 145–150  
 geometric wrap, 124–126  
 label attachment, 204  
 lacy bolero, 133–137  
 pattern size selection, 27–29  
 red velvet crusher hat, 80–81  
 shaping, 52  
 sizing, 24–27  
 shell stitch tank top, 141–145  
 southwest vest, 114–116  
 springtime pullover, 138–141  
 velvet roses, 192–194  
 vertical stripes tunic, 127–133
- cluster stitch  
 combination stitch, 41  
 shells and lace pillowcase edging, 173  
 technique illustrated, 240–241  
 triangles, 41  
 wavy chevron throw, 91
- coasters, geometric coaster set, 185–189
- Coats & Clark Inc., 253
- coffee suede beret project, 76–79
- coilless safety pins, kit component, 19
- collar, fur-trimmed jacket, 150
- color changes, adding new yarn, 42–44
- color drag, prevention techniques, 43
- color name/number, label information, 13–14
- colors, adding new yarn, 42–44
- combination stitches  
 bobble, 42  
 cluster, 41  
 crossed double crochet stitch, 41  
 double crochet stitch, 40  
 double-crossing belt, 119–121  
 elegant evening wrap, 117–119  
 geometric wrap, 124–126  
 love those loops scarf, 121–124  
 picot, 41  
 popcorn stitch, 42  
 puff stitch, 41  
 reverse single crochet, 41  
 shell stitch, 41  
 slip stitch, 39  
 triple crochet stitch, 40  
 v-stitch, 41
- company name/logo, label information, 13–14
- complements, wire-'n'-beads necklace, 180
- Continental, hook sizing conventions, 9–10
- contrasting color (CC), 32, 247
- copper-coated wire, wire-'n'-beads necklace, 179
- cords  
 drawstring, 84  
 hemp basket, 178
- cosmetics pouch, gear storage, 18
- cotton flake yarn, thick/thin spots, 138
- cotton, natural fiber, 13
- cozy chenille throw rug project, 92–95
- craft category, bulky yarn, 12
- craft glue, must-see fur frame, 200
- crochet bag, gear storage, 18
- crochet hooks. *See* hooks
- crochet thread  
 blocking, 206  
 diamond-shaped table runner, 68  
 double-crossing belt, 120  
 friendship bracelet, 191  
 lacy bookmark, 183  
 love-to-read bookmark, 161  
 shells and lace pillowcase edging, 173  
 stemmed-glass markers, 198  
 velvet roses, 193
- Crocheting For Dummies* (Susan Brittain), 3, 4
- cross (†) character, pattern instructions, 34
- cross back, sizing measurements, 25–26
- crossed double crochet stitch  
 combination stitch, 41  
 double-crossing belt, 120  
 technique illustrated, 238–239
- cuffs, fur-trimmed jacket, 150
- curlicue scarf project, 70–71
- D •
- dc. *See* double crochet stitch (dc)
- decreases. *See also* increases; stitches  
 1 double crochet stitch (dec 1 dc), 237–238  
 1 single crochet stitch (dec 1 sc), 236
- beaded-fringe belt, 64
- blocks, 161
- diamond-shaped table runner, 68
- rows/rounds, 47–49
- shades-of-gray shawl, 67
- skipping stitches, 49
- southwest vest, 114
- spaces, 161
- springtime pullover, 139
- standout luggage tags, 201

## decreases (*continued*)

- think pink pocket purse, 224
- wear your heart pin, 211
- working in rounds, 52
- denim cloche project, 87–90
- denim skirt project, 73–76
- diagrams, pattern instructions, 36–38
- diamond-shaped table runner project, 68–69
- DK weight, yarn weight/texture, 12
- DMC Corporation, 253
- double bullets (••), pattern instructions, 34–35
- double crochet stitch (dc)
  - adding new yarn, 42–43
  - adult’s rolled-brim hat, 104
  - afghan stitch baby blanket, 154
  - bella drawstring bag, 82
  - child’s rolled-brim hat, 102
  - chocolate lace headband, 221
  - cluster stitch combination, 41
  - crossed double crochet stitch combination, 41
  - curlicue scarf, 70
  - decreases, 48–49
  - denim cloche, 88
  - double-crossing belt, 120
  - elegant evening wrap, 118
  - flower-power belt, 112
  - flirty denim skirt, 74
  - geometric wrap, 125
  - heartland window valance, 167
  - increases, 47
  - lacy bolero, 134
  - lacy bookmark, 183
  - love-to-read bookmark, 161
  - not your granny’s scarf, 170
  - pocket patch, 195
  - puff stitch combination, 41
  - shell stitch combination, 41
  - shell stitch tank top, 142
  - shells and lace pillowcase edging, 173
  - technique illustrated, 232–233
  - turning chains, 40
  - uses, 40
  - velvet roses, 193
  - v-stitch combination, 41
  - wavy chevron throw, 91
  - wooly warmer afghan, 61
- double ended crochet, 8
- double ended crochet hooks, uses, 8
- double knitting category, light yarn, 12
- double triple crochet stitch (dtr)
  - page runner, 217
  - technique illustrated, 234–235

- turning chains, 40
- uses, 40

- double-crossing belt project, 119–121
- drawstring bag project, 82–84
- drawstring cord, bella drawstring bag, 84
- drawstring ties, denim skirt, 76
- dry cleaning, project care, 206
- dtr. *See* double triple crochet stitch (dtr)
- dye lot number, label information, 13–14

## • E •

- earring hoop wires, stemmed-glass markers, 198

- ease, garment fit, 25

### edgings

- afghan stitch baby blanket, 155
- beadies can-cozy, 217
- beads-’n’-bows belt, 100
- cozy chenille throw rug, 95
- diamond-shaped table runner, 69
- geometric coaster set, 187–188
- heartland window valance, 168
- hiding yarn strands, 45
- lacy bolero, 137
- love those loops scarf, 123, 124
- picot stitch, 41
- pillowcase stitch diagram, 38
- pocket patch, 197
- practical potholders, 57
- reverse single crochet stitch, 41
- ruffles-’n’-bows scarf, 101
- shades-of-gray shawl, 67
- shell stitch tank top, 145
- shells and lace pillowcase, 172–174
- springtime pullover, 141
- Tunisian stitch tote bag, 158
- vertical stripes tunic, 132
- weaving yarn ends, 46

- elastic, fun fur scrunchies, 190

- elegant evening wrap project, 117–119

- embellishments, pocket patches, 194–197

- end-of-row, adding new yarn, 42–43

- established pat, pattern instructions, 33

- evening wraps, elegant evening wrap, 117–119

- eyelash yarn, yarn weight/texture, 12

## • F •

- fabric tape measure

- garment sizing, 24–27

- kit component, 19

- fake fur, yarn weight/texture, 12



- fancy filet crochet stitch, heartland window valance, 163–166
- felting
- honey, I shrunk my bag, 174–176
  - wear your heart pin, 212
- fibers
- blends, 13
  - felting, 174
  - label information, 13–14
  - natural, 13
  - synthetic, 13
- fine, yarn category, 12
- fingering category, super fine yarn, 12
- fingering weight, yarn weight/texture, 12
- finishing
- bella drawstring bag, 84
  - coffee suede beret, 79
  - double-crossing belt, 121
  - flirty denim skirt, 76
  - friendship bracelet, 191–192
  - handy headband, 59
  - honey, I shrunk my bag, 176
  - lacy bookmark, 184
  - love those loops scarf, 123, 124
  - love-to-read bookmark, 163
  - page runner, 218
  - pocket patch, 196–197
  - practical potholders, 57
  - shells and lace pillowcase edging, 174
  - standout luggage tags, 202
- flirty denim skirt project, 73–76
- flower-power belt project, 111–113
- forehead, sizing measurements, 26
- foundation chain
- attaching edgings, 174
  - becoming a round, 70
  - chain stitch (ch), 230
  - decreasing project size, 71, 95
  - definition, 38
  - increasing project size, 62, 95
  - joining, 73
- foundation rows
- afghan stitch baby blanket, 152–154
  - Tunisian stitch tote bag, 157–158
- FPdc. *See* front post double crochet (FPdc)
- frames, must-see fur, 199–200
- freezer bag, project component storage, 18
- friendship bracelet project, 190–192
- fringe
- beaded-fringe belt, 66
  - cozy chenille throw rug, 95
  - elegant evening wrap, 119
  - geometric wrap, 126
  - technique illustrated, 248
- front post double crochet (FPdc), technique illustrated, 244–245
- fun fur scrunchies project, 189–190
- fur-like fabric, love those loops scarf, 124
- furry boa pillow project, 109–111
- fur-trimmed jacket project, 145–150
- **G** •
- garment sizes, parentheses ( and ) characters, 35
- garments. *See also* clothing; items; projects
- avoiding hangers, 207
  - ease of fit, 25
  - natural fibers, 13
  - pattern sizing guidelines, 27–29
  - sizing, 24–27
- gauge
- definition, 21
  - gauge swatch, 21–24
  - manufacturer's recommendation, 13–14
  - measuring, 22–24
  - yarn substitution, 97
- gauge swatch
- blocking, 22
  - measurement guidelines, 22–24
  - pattern adjustments, 24
  - pattern sample, 21–24
  - stitching a square, 22
  - working a round, 22
- geometric coaster set project, 185–189
- geometric wrap project, 124–126
- glue, must-see fur frame, 200
- granny squares
- afghan, 171–172
  - not your granny's scarf, 169–171
- **H** •
- half double crochet stitch (hdc)
- cluster stitch combination, 41
  - cozy chenille throw rug, 93
  - curlicue scarf, 70
  - double-crossing belt, 120
  - flower-power belt, 112
  - fur-trimmed jacket, 146
  - honey, I shrunk my bag, 175
  - shades-of-gray shawl, 67
  - southwest vest, 114
  - technique illustrated, 235–236
  - turning chain, 40
  - uses, 40
  - velvet roses, 193

half double crochet stitch (hdc) (*continued*)  
 vertical stripes tunic, 128  
 wooly warmer afghan, 61

half-closed stitches, puff stitch combination, 41

hand washing, recommended care, 205

handle  
 hook design element, 7  
 honey, I shrunk my bag, 176  
 Tunisian stitch tote bag, 158

hands  
 over-the-hook position, 16–18  
 under-the-hook position, 16–18  
 yarn handling position, 16–18

handy headbands project, 57–59

hangers, avoiding, 207

hard ruler, kit component, 19

hats  
 adult's rolled-brim, 103–105  
 carrying yarn across rows, 45  
 child's rolled-brim, 101–103  
 coffee suede beret, 76–79  
 denim cloche, 87–90  
 fit adjustments, 27  
 red velvet crusher, 80–81  
 shaping, 52  
 sizing measurements, 26

hdc. *See* half double crochet stitch (hdc)

headbands  
 chocolate lace, 220–221  
 handy, 57–59

heads  
 size charts, 29  
 sizing measurements, 26

heartland window valance project, 163–168

heights, stitch variations, 39–40

hemp basket project, 176–178

hems  
 flirty denim skirt, 76  
 ruffled, 76

Herrschners, 253

hole punch, MP3 player cover, 213

honey, I shrunk my bag project, 174–176

hook size, label information, 13–14

hooks  
 afghan, 8  
 aluminum, 8  
 beginner suggestions, 15  
 cleaning, 10  
 design elements, 7–8  
 double ended crochet, 8  
 gauge variation results, 97  
 illustration, 9  
 left-handed use, 15–16  
 length guidelines, 8  
 material types, 8

plastic, 8  
 sizing conventions, 9–10  
 standard category, 8  
 steel, 8  
 storage cases, 11  
 wood, 8

horizontal stripe pattern, hiding yarn strands, 45

household item display, 207

## • 1 •

increases. *See also* decreases; stitches  
 blocks, 165–166  
 rows/rounds, 46–47  
 spaces, 165–166  
 working in rounds, 51–52

International Crochet Symbols, stitch symbols,  
 36–37

in-the-round. *See also* rounds  
 adult's rolled-brim hat, 103–105  
 beadies can-cozy, 216  
 bella drawstring bag, 82–84  
 center ring, 50  
 child's rolled-brim hat, 101–103  
 coffee suede beret, 76–79  
 decreases, 52  
 denim cloche, 87–90  
 end joins, 51  
 flower-power belt, 111–113  
 gauge swatch, 22  
 gauge swatch measurement, 24  
 hemp basket, 177–178  
 increases, 51–52  
 must-see fur frame, 200  
 red velvet crusher hat, 80–81  
 shapes, 52  
 spirals, 52  
 stitch markers, 49  
 velvet roses, 193–194

ironing, cautions/concerns, 207

items. *See also* garments; projects  
 avoiding hangers, 207  
 care instruction storage, 203–204  
 dry cleaning, 206  
 home decor display, 207  
 long-term storage, 207

## • 1 •

jacket, fur-trimmed, 145–150

joins  
 adding new yarn, 42–44  
 coffee suede beret, 79  
 slip stitch, 39

spirals, 52  
 working in rounds, 51  
 jump rings  
 beaded anklet, 226  
 chain-link bracelet, 222

## ● **K** ●

keys  
 geometric coaster set, 186–188  
 heartland window valance, 167  
 love-to-read bookmark, 162  
 kid-friendly projects. *See also* projects  
 beaded anklet, 225–226  
 beadies can-cozy, 215–217  
 blue note scarf, 209–210  
 camouflage belt, 218–220  
 chain-link bracelet, 221–223  
 chocolate lace headband, 220–221  
 MP3 player cover, 213–215  
 page runner, 217–218  
 think pink pocket purse, 223–225  
 wear your heart pin, 210–212

## ● **L** ●

labels  
 attaching to a project, 204  
 care instructions, 203–204  
 dry cleaning only, 206  
 gauge, 13–14  
 hook size information, 9  
 information types, 13–14  
 saving for future reference, 203–204  
 lace patterns, double triple crochet stitch, 40  
 lacets, fancy filet crochet stitch, 163–164  
 lacy bolero project, 133–137  
 lacy bookmark project, 183–185  
 lacy designs, weaving yarn ends, 46  
 left-handers  
 hook holding, 16  
 technique suggestions, 15–16  
 yarn handling, 16–17  
 letters, hook sizing conventions, 9–10  
 light worsted category, light yarn, 12  
 light, yarn category, 12  
 Lily Sugar n Cream, 253  
 Lion Brand Yarn, 253  
 long (spike) stitch, technique illustrated, 247  
 long single crochet stitch (lsc)  
 beads-'n'-bows belt, 99  
 coffee suede beret, 77  
 cozy chenille throw rug, 93  
 ruffles-'n'-bows scarf, 101  
 loop stitch, love those loops scarf, 122–123

loops  
 bobble stitch combination, 42  
 pattern instructions, 33  
 love those loops scarf project, 121–124  
 love-to-read bookmark project, 158–163  
 lsc. *See* long single crochet stitch  
 luggage tags, standout luggage tags, 200–202

## ● **M** ●

machine drying, synthetic yarns, 206–207  
 machine washing, synthetic yarns, 206  
 manufacturer's address, label information, 13–14  
 markers, stemmed-glass, 197–199  
 measurements  
 garment sizing, 24–27  
 gauge swatch, 22–24  
 sizing, 25–27  
 measuring tape  
 garment sizing, 24–27  
 kit component, 19  
 medium, yarn category, 12  
 men, size charts, 29  
 middle-of-a-row  
 adding new yarn, 43–44  
 skipping stitches, 49  
 mittens, shaping, 52  
 Moda Dea, 253  
 mohair, yarn weight/texture, 12  
 motifs  
 flower-power belt, 112–113  
 not your granny's scarf, 170–171  
 pocket patches, 194–195  
 repeated figure design, 109  
 MP3 player cover, kid-friendly project, 213–215  
 Muench Yarns, 253  
 must-see fur frame project, 199–200

## ● **N** ●

nail polish (clear), stemmed-glass markers, 198  
 names, yarn conventions, 11–12  
 natural fibers, yarn material type, 13  
 necklace clasp, wire-'n'-beads necklace, 179  
 necklace, wire-'n'-beads, 178–180  
 needles  
 tapestry, 19  
 yarn, 19  
 not your granny's scarf project, 169–172  
 notebooks  
 care instruction storage, 203–204  
 kit component, 19  
 numbers, hook sizing conventions, 9–10

## • O •

open designs, weaving yarn ends, 46  
 ovals, puff stitch, 41  
 over-the-hook, hand position, 16–18

## • P •

page runner, kid-friendly project, 217–218  
 panels, afghan stitch baby blanket project, 154–155  
 parentheses ( and ) characters, pattern instructions, 35  
 Patons Yarns, 253  
 patterns  
   abbreviations, 32–33  
   common terms, 33  
   diagram conventions, 36–38  
   garment sizing guidelines, 27–29  
   International Crochet Symbols, 36–37  
   reading/understanding written instructions, 31–36  
   reduced sample, 38  
   symbols, 33–35  
   turning chain instructions, 41  
   yarn substitution guidelines, 15  
 pencil/paper, kit component, 19  
 pets, yarn cautions/concerns, 18  
 photo frame, must-see fur frame, 200  
 phrases, brackets [ and ] characters, 36  
 picot stitch  
   bella drawstring bag, 82  
   combination stitch, 41  
   edgings, 41  
   flirty denim skirt, 74  
   shells and lace pillowcase edging, 173  
   stemmed-glass markers, 198  
   technique illustrated, 239–240  
 picture frames, must-see fur, 199–200  
 pillow forms, furry boa pillow, 110  
 pillowcase edging, stitch diagram, 38  
 pillowcases, shells and lace pillowcase edging, 172–174  
 pillow, furry boa, 109–111  
 pills, removal techniques, 208  
 pin back, wear your heart pin, 211  
 pin, wear your heart pin, 210–212  
 pins (straight), kit component, 19  
 placemats, geometric coaster set, 189  
 plastic hooks  
   cleaning, 10  
   pros/cons, 8  
 plastic storage bins, long-term storage, 207  
 plus sign (+), pattern instructions, 34  
 ply, label information, 13–14  
 Plymouth Yarn, 253

pocket patches project, 194–197  
 point, hook design element, 7–8  
 pompoms, love those loops scarf, 123, 124  
 pop/pc. *See* popcorn stitch  
 popcorn stitch (pop/pc)  
   combination stitch, 42  
   technique illustrated, 242–243  
 practical potholders project, 55–57  
 projects. *See also* kid-friendly projects  
   adult’s rolled-brim hat, 103–105  
   afghan stitch baby blanket, 151–155  
   beaded-fringe belt, 63–66  
   beads-’n’-bows belt, 98–100  
   bella drawstring bag, 82–84  
   care instruction storage, 203–204  
   child’s rolled-brim hat, 101–103  
   coffee suede beret, 76–79  
   cozy chenille throw rug, 92–95  
   curlicue scarf, 70–71  
   denim cloche, 87–90  
   diamond-shaped table runner, 68–69  
   double-crossing belt, 119–121  
   dry cleaning, 206  
   elegant evening wrap, 117–119  
   flirty denim skirt, 73–76  
   flower-power belt, 111–113  
   friendship bracelet, 190–192  
   fun fur scrunchies, 189–190  
   furry boa pillow, 109–111  
   fur-trimmed jacket, 145–150  
   geometric coaster set, 185–189  
   geometric wrap, 124–126  
   handy headbands, 57–59  
   heartland window valance, 163–168  
   hemp basket, 176–178  
   honey, I shrunk my bag, 174–176  
   label attachment, 204  
   lacy bolero, 133–137  
   lacy bookmark, 183–185  
   love those loops scarf, 121–124  
   love-to-read bookmark, 158–163  
   must-see fur frame, 199–200  
   not your granny’s scarf, 169–172  
   pocket patches, 194–197  
   practical potholders, 55–57  
   red velvet crusher hat, 80–81  
   ruffles-’n’-bows scarf, 100–101  
   scarf of a different color, 85–87  
   shades-of-gray shawl, 66–67  
   shell stitch tank top, 141–145  
   shells and lace pillowcase edging, 172–174  
   smart scarf, 59–60  
   southwest vest, 114–116  
   springtime pullover, 138–141  
   standout luggage tags, 200–202  
   stemmed-glass markers, 197–199  
   Tunisian stitch tote bag, 155–158

velvet roses, 192–194  
 vertical stripes tunic, 127–133  
 wavy chevron throw, 90–92  
 wire-'n'-beads necklace, 178–180  
 wooly warmer afghan, 60–62  
 puff stitch  
   combination stitch, 41  
   technique illustrated, 242  
 pullover, springtime, 138–141  
 purse, think pink pocket purse, 223–225

## • R •

red velvet crusher hat project, 80–81  
 reduced sample, patterns, 38  
 repeats  
   pattern instructions, 36  
   stitch diagrams, 37  
 resources, yarn supply, 253  
 reverse sc. *See* reverse single crochet stitch  
 reverse single crochet stitch (reverse sc)  
   beadies can-cozy, 216  
   combination stitch, 41  
   technique illustrated, 241  
 ribbons, friendship bracelet, 192  
 right-handers  
   hook holding, 16  
   yarn handling, 16–17  
 right-side rows  
   carrying yarn across, 44  
   stitch diagram numbering conventions, 38  
 rounds. *See also* in-the-round  
   decreases, 47–49  
   parentheses ( and ) characters, 35  
   repeat instructions, 36  
   slip stitch, 39  
   stitch diagrams, 37  
   turning chains, 40–41  
 roving category, super bulky yarn, 12  
 Rowan Yarns, 253  
 rows  
   adding new yarn, 42–44  
   decreases, 47–49  
   gauge swatch measurement, 23  
   increases, 46–47  
   parentheses ( and ) characters, 35  
   repeat instructions, 36  
   stitch diagram numbering conventions, 38  
   stitch diagrams, 37  
   triple crochet stitch, 40  
   turning chains, 40–41  
   weaving yarn ends, 46  
 ruffled hem, flirty denim skirt, 76  
 ruffles-'n'-bows scarf project, 100–101

rug, cozy chenille, 92–95  
 rugs category, bulky yarn, 12

## • S •

safety pins, kit component, 19  
 sc. *See* single crochet stitch (sc)  
 scarf of a different color project, 85–87  
 scarves  
   blue note, 209–210  
   curlicue, 70–71  
   hiding yarn strands, 45  
   love those loops, 121–124  
   not your granny's, 169–171  
   ruffles-'n'-bows, 100–101  
   scarf of a different color, 85–87  
   smart, 59–60  
   working over the strand, 45  
 schematics  
   flirty denim skirt, 75  
   fur-trimmed jacket, 146  
   lacy bolero, 134  
   shell stitch tank top, 143  
   southwest vest, 115  
   springtime pullover, 139  
   vertical stripes tunic, 129  
 scissors  
   kit component, 19  
   pill removal, 208  
 scrunchies, fun fur, 189–190  
 seams  
   hiding yarn strands, 45  
   slip stitch, 39  
   weaving yarn ends, 46  
 self-striping yarn, blue note scarf, 209–210  
 sewing needles  
   friendship bracelet, 191  
   fun fur scrunchies, 190  
   fur-trimmed jacket, 146  
   shells and lace pillowcase edging, 173  
   think pink pocket purse, 223  
   wear your heart pin, 211  
 sewing seams, slip stitch, 39  
 sewing thread  
   friendship bracelet, 191  
   fun fur scrunchies, 190  
   fur-trimmed jacket, 146  
   shells and lace pillowcase edging, 173  
   think pink pocket purse, 223  
   wear your heart pin, 211  
 sew-on snaps, friendship bracelet, 191  
 shades-of-gray shawl project, 66–67  
 shaft, hook design element, 7  
 shank button, standout luggage tags, 201

- shapes, working in rounds, 52
- shaping, clothing, 52
- shawls
  - evening wrap, 117–119
  - geometric wrap, 124–126
  - shades-of-gray, 66–67
  - working over the strand, 45
- shell stitch
  - afghan stitch baby blanket, 154
  - beads-’n’-bows belt, 99
  - bella drawstring bag, 82
  - flirty denim skirt, 74
  - lacy bolero, 134
  - lacy bookmark, 183
  - ruffles-’n’-bows scarf, 101
  - shell stitch tank top, 142
  - shells and lace pillowcase edging, 173
  - technique illustrated, 239
  - wavy chevron throw, 91
- shell stitch tank top project, 141–145
- shells and lace pillowcase edging project, 172–174
- shoulder strap, think pink pocket purse, 225
- silk, natural fiber, 13
- single bullet (•) character, pattern
  - instructions, 34
- single crochet stitch (sc)
  - afghan stitch baby blanket, 154
  - beaded anklet, 226
  - beaded-fringe belt, 64
  - beadies can-cozy, 216
  - beads-’n’-bows belt, 99
  - bella drawstring bag, 82
  - blue note scarf, 210
  - camouflage belt, 219
  - chocolate lace headband, 221
  - coffee suede beret, 77
  - cozy chenille throw rug, 93
  - curlicue scarf, 70
  - denim cloche, 88
  - diamond-shaped table runner, 68
  - double-crossing belt, 120
  - flirty denim skirt, 74
  - flower-power belt, 112
  - friendship bracelet, 191
  - fun fur scrunchies, 190
  - furry boa pillow, 110
  - fur-trimmed jacket, 146
  - geometric coaster set, 186
  - handy headbands, 58
  - heartland window valance, 167
  - hemp basket, 177
  - honey, I shrunk my bag, 175
  - lacy bolero, 134
  - lacy bookmark, 183
  - love those loops scarf, 123
  - MP3 player cover, 213
  - must-see fur frame, 200
  - not your granny’s scarf, 170
  - page runner, 217
  - pocket patch, 195
  - practical potholders, 56
  - red velvet crusher hat, 80
  - reverse single crochet combination, 41
  - ruffles-’n’-bows scarf, 101
  - scarf of a different color, 86
  - shades-of-gray shawl, 67
  - shell stitch tank top, 142
  - shells and lace pillowcase edging, 173
  - smart scarf, 59–60
  - springtime pullover, 139
  - standout luggage tags, 201
  - stemmed-glass markers, 198
  - technique illustrated, 232
  - think pink pocket purse, 224
  - Tunisian stitch tote bag, 157
  - turning chain, 40
  - uses, 39
  - velvet roses, 193
  - wear your heart pin, 211
  - wooly warmer afghan, 61
  - working in rounds, 50–51
- size
  - adjusting fit, 26–27
  - body measurements, 25–26
  - garments, 24–27
  - parentheses ( and ) characters, 35
  - pattern size selection, 27–29
- size charts
  - babies, 28
  - children, 28
  - heads, 29
  - men, 29
  - women, 28–29
- skirts
  - denim, 73–76
  - fit adjustments, 27
  - sizing measurements, 26
- sl st. *See* slip stitch (sl st)
- sleeve length, sizing measurements, 25–26
- slip stitch (sl st)
  - adult’s rolled-brim hat, 104
  - afghan stitch baby blanket, 154
  - beaded anklet, 226
  - beadies can-cozy, 216
  - bella drawstring bag, 82
  - child’s rolled-brim hat, 102
  - coffee suede beret, 77
  - cozy chenille throw rug, 93
  - curlicue scarf, 70

- denim cloche, 88
- diamond-shaped table runner, 68
- flirty denim skirt, 74
- flower-power belt, 112
- fun fur scrunchies, 190
- fur-trimmed jacket, 146
- geometric coaster set, 186
- heartland window valance, 167
- hemp basket, 177
- honey, I shrunk my bag, 175
- joining ends, 51
- lacy bolero, 134
- lacy bookmark, 183
- love-to-read bookmark, 161
- MP3 player cover, 213
- must-see fur frame, 200
- not your granny's scarf, 170
- picot stitch combination, 41
- pocket patch, 195
- practical potholders, 56
- red velvet crusher hat, 80
- scarf of a different color, 86
- shades-of-gray shawl, 67
- shell stitch tank top, 142
- shells and lace pillowcase edging, 173
- southwest vest, 114
- spiral joins, 52
- springtime pullover, 139
- stemmed-glass markers, 198
- technique illustrated, 231
- Tunisian stitch tote bag, 157
- turning chains, 40
- uses, 39
- velvet roses, 193
- vertical stripes tunic, 128
- slipknot, technique illustrated, 17, 229–230
- smart scarf project, 59–60
- sock category, super fine yarn, 12
- socks, shaping, 52
- solid patterns, weaving yarn ends, 46
- South West Trading Company, 253
- southwest vest project, 114–116
- spaces
  - basic filet crochet stitch, 158–159, 161
  - fancy filet crochet stitch, 163, 165–166
  - pattern instructions, 33
- spirals, working in, 52
- sport category, fine yarn, 12
- sport weight, yarn weight/texture, 12
- spring ring clasp
  - beaded anklet, 226
  - chain-link bracelet, 222
- springtime pullover project, 138–141
- squares, gauge swatch, 22
- standard hooks
  - diameter ranges, 8
  - sizing conventions, 9–10
- standout luggage tags project, 200–202
- steam blocking, gauge swatch, 22
- steel hooks
  - cleaning, 10
  - size ranges, 8
  - sizing conventions, 9–10
- stitch diagrams
  - beads-'n'-bows belt, 99
  - double-crossing belt, 120
  - elegant evening wrap, 119
  - flower-power belt, 112–113
  - geometric wrap, 125
  - lacy bookmark, 185
  - not your granny's scarf, 171
  - page runner, 218
  - pattern instructions, 36–38
  - pocket patches, 196
  - reduced sample, 38
  - ruffles-'n'-bows scarf, 99
  - shells and lace pillowcase edging, 173
  - stemmed glass markers, 198
  - velvet roses, 194
  - wavy chevron throw, 91
- stitch markers
  - beadies can-cozy, 216
  - bella drawstring bag, 82
  - coffee suede beret, 77
  - kit component, 19
  - MP3 player cover, 213
  - red velvet crusher hat, 80
  - working in rounds, 49
- stitches. *See also* combination stitches;
  - decreases; increases
  - afghan, 152–153
  - back post double crochet (BPdc), 246
  - basic filet crochet, 158–161
  - blanket stitch, 250–251
  - bobble stitch, 244
  - brackets [ and ] characters, 36
  - chain stitch (ch), 230
  - cluster stitch, 240–241
  - combinations, 41–42
  - crossed double crochet stitch, 238–239
  - decreases, 47–49
  - double crochet stitch (dc), 40, 232–233
  - double triple crochet (dtr), 40, 234–235
  - fancy filet crochet, 163–166
  - front post double crochet (FPdc), 244–245
  - gauge swatch measurement, 23
  - half double crochet stitch (hdc), 40, 235–236
  - height variations, 39–40
  - illustrated, 229–251
  - increases, 46–47
  - International Crochet Symbols, 36–37
  - long (spike) stitch, 247
  - parentheses ( and ) characters, 35

## stitches (*continued*)

- picot stitch, 239–240
- popcorn stitch (pop/pc), 242–243
- puff stitch, 242
- reverse single crochet stitch (reverse sc), 241
- shell stitch, 239
- single crochet stitch (sc), 39, 232
- skipping, 49
- slip stitch (sl st), 39, 231
- slipknot, 17, 229–230
- triple crochet stitch (tr), 40, 233–234
- Tunisian knit, 156–157
- turning chains, 40–41
- V-stitch, 238
- whipstitch, 250
- straight pins, kit component, 19
- super bulky, yarn category, 12
- super fine, yarn category, 12
- sweater shaver, pill removal, 208
- sweater stone, pill removal, 208
- sweaters
  - carrying yarn across rows, 45
  - fit adjustments, 26–27
  - fur-trimmed jacket, 145–150
  - lacy bolero, 133–137
  - shell stitch tank top, 141–145
  - sizing measurements, 25–26
  - springtime pullover, 138–141
  - vertical stripes tunic, 127–133
- symbols
  - International Crochet Symbols, 36–37
  - label information, 13–14
  - pattern instructions, 33–35
  - yarn weight, 12
- synthetic fibers, yarn material type, 13
- synthetic yarns
  - machine drying, 206–207
  - machine washing, 206

## • T •

- table runners
  - diamond-shaped, 68–69
  - geometric coaster set, 189
  - home decor display, 207
- tags, standout luggage, 200–202
- tank top, shell stitch, 141–145
- tape measure
  - garment sizing, 24–27
  - kit component, 19
- tapestry needles
  - camouflage belt, 219
  - chocolate lace headband, 221
  - double-crossing belt, 120
  - handy headbands, 58
  - kit component, 19

- lacy bolero, 134
- MP3 player cover, 213
- pocket patch, 195
- shell stitch tank top, 142
- springtime pullover, 138
- standout luggage tags, 201
- vertical stripes tunic, 128
- tassels
  - lacy bookmark, 184
  - technique illustrated, 249
  - wavy chevron throw, 92
- think pink pocket purse, kid-friendly project, 223–225
- thread. *See* crochet thread; sewing thread
- threadwork, double triple crochet stitch, 40
- throat, hook design element, 7–8
- throw rug, cozy chenille, 92–95
- throws. *See also* afghans
  - wavy chevron, 90–92
  - working over the strand, 45
- thumb rest, hook design element, 7
- ties
  - beads-'n'-bows belt, 100
  - drawstring, 76
- tissue paper, item storage, 207
- tote bag, Tunisian stitch, 155–158
- tr. *See* triple crochet stitch (tr)
- travel, slip stitch, 39
- triangles
  - cluster stitch, 41
  - geometric wrap, 124–126
- triple crochet stitch (tr)
  - cluster stitch combination, 41
  - double-crossing belt, 120
  - puff stitch combination, 41
  - technique illustrated, 233–234
  - turning chain decrease, 48
  - turning chain, 40
  - uses, 40
  - velvet roses, 193
  - wooly warmer afghan, 61
- tunic, vertical stripes, 127–133
- Tunisian knit stitch, 156–157
- Tunisian stitch tote bag project, 155–158
- turning chains
  - decreases, 48
  - skipping stitches, 49
  - stitch variations, 40–41
- Twilleys of Stanford, 253

## • U •

- under-the-hook, hand position, 16–18
- United Kingdom, hook sizing conventions, 9–10
- United States, hook sizing conventions, 9–10



• **V** •

variations

- afghan stitch baby blanket, 155
- beaded-fringe belt, 66
- bella drawstring bag, 84
- chain-link bracelet, 223
- coffee suede beret, 79
- cozy chenille throw rug, 95
- curlicue scarf, 71
- diamond-shaped table runner, 69
- flower-power belt, 113
- friendship bracelet, 192
- geometric coaster set, 189
- geometric wrap, 126
- granny squares, 171–172
- heartland window valance, 168
- hemp basket, 178
- honey, I shrunk my bag, 176
- love those loops scarf, 124
- potholder, 57
- southwest vest, 116
- stemmed-glass markers, 199
- think pink pocket purse, 224–225
- wavy chevron throw, 92
- wire-'n'-beads necklace, 180
- wooly warmer afghan, 62

variegated yarn, 11

velvet roses project, 192–194

vertical stripes tunic project, 127–133

vests

- fit adjustments, 26–27
- shaping, 115–116
- sizing measurements, 25–26
- southwest, 114–116

vinyl window, MP3 player cover, 214

visors, coffee suede beret, 79

V-stitch

- combination stitch, 41
- geometric wrap, 125
- technique illustrated, 238

• **W** •

waistband, flirty denim skirt, 76

waists, sizing measurements, 26

wavy chevron throw, 90–92

wear your heart pin, kid-friendly project, 210–212

weaving, yarn ends, 46

Web sites

- Bernat Yarns, 253
- Caron International, 253
- Coats & Clark Inc., 253
- DMC Corporation, 253
- Herrschners, 253

- Lily Sugar n Cream, 253
- Lion Brand Yarn, 253
- Moda Dea, 253
- Muench Yarns, 253
- Patons Yarns, 253
- Plymouth Yarn, 253
- South West Trading Company, 253
- Twilleys of Stanford, 253

weight

- label information, 13–14
- yarn conventions, 11–12
- yarn substitution guidelines, 15

wet blocking, gauge swatch, 22

whipstitch

- furry boa pillow, 111
- fur-trimmed jacket, 149
- shell stitch tank top, 145
- southwest vest, 116
- springtime pullover, 141
- technique illustrated, 250
- vertical stripes tunic, 133

window border, MP3 player cover, 214

window valance, heartland, 163–168

wine glass, stemmed-glass markers, 197–199

wire-'n'-beads necklace project, 178–180

women, size charts, 28–29

wood hooks

- cleaning, 10
- pros/cons, 8

wool fibers, felting, 174

wool, natural fiber, 13

wooly warmer afghan project, 60–62

work across, pattern instructions, 33

work around, pattern instructions, 33

work even, pattern instructions, 33

work to within last st, pattern instructions, 33

worsted category

- medium yarn, 12
- beginners, 15

worsted weight, yarn weight/texture, 12

wraps

- elegant evening, 117–119
- geometric, 124–126

wrong-side rows

- carrying yarn across, 44
- stitch diagram numbering conventions, 38

• **Y** •

yardage

- label information, 13–14
- yarn substitution guidelines, 15

yarn

- adding to a row, 42–44
- beginner suggestions, 15
- blends, 13

yarn (*continued*)

- carrying across rows, 44–46
  - carrying up the side, 45
  - category names, 12
  - cotton flake, 138
  - gauge variation results, 97
  - handling guidelines, 16–17
  - illustrated weights, 12
  - label information, 13–14
  - material types, 13
  - pattern substitution guidelines, 15
  - pills, 208
  - price ranges, 13
  - self-stripping, 209
  - supply sources, 253
  - symbols, 12
  - variegated, 11
  - weaving, 46
  - weights, 11–12
  - working over the strand, 45
- yarn needles
- adult's rolled-brim hat, 104
  - child's rolled-brim hat, 102
  - furry boa pillow, 110
  - fur-trimmed jacket, 146
  - kit component, 19
  - not your granny's scarf, 170
  - southwest vest, 114
  - think pink pocket purse, 223
  - Tunisian stitch tote bag, 157
- yarn-weight symbol, label information, 13–14

**• Z •**

- zippered bag, gear storage, 18





## BUSINESS, CAREERS & PERSONAL FINANCE

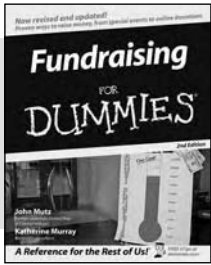

0-7645-9847-3

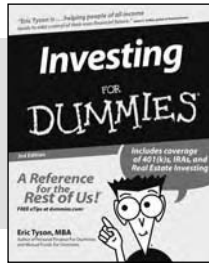

0-7645-2431-3

### Also available:

- ✓ Business Plans Kit For Dummies 0-7645-9794-9
- ✓ Economics For Dummies 0-7645-5726-2
- ✓ Grant Writing For Dummies 0-7645-8416-2
- ✓ Home Buying For Dummies 0-7645-5331-3
- ✓ Managing For Dummies 0-7645-1771-6
- ✓ Marketing For Dummies 0-7645-5600-2
- ✓ Personal Finance For Dummies 0-7645-2590-5\*
- ✓ Resumes For Dummies 0-7645-5471-9
- ✓ Selling For Dummies 0-7645-5363-1
- ✓ Six Sigma For Dummies 0-7645-6798-5
- ✓ Small Business Kit For Dummies 0-7645-5984-2
- ✓ Starting an eBay Business For Dummies 0-7645-6924-4
- ✓ Your Dream Career For Dummies 0-7645-9795-7

## HOME & BUSINESS COMPUTER BASICS

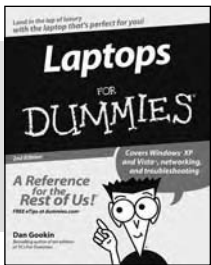

0-470-05432-8

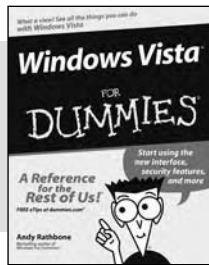

0-471-75421-8

### Also available:

- ✓ Cleaning Windows Vista For Dummies 0-471-78293-9
- ✓ Excel 2007 For Dummies 0-470-03737-7
- ✓ Mac OS X Tiger For Dummies 0-7645-7675-5
- ✓ MacBook For Dummies 0-470-04859-X
- ✓ Macs For Dummies 0-470-04849-2
- ✓ Office 2007 For Dummies 0-470-00923-3
- ✓ Outlook 2007 For Dummies 0-470-03830-6
- ✓ PCs For Dummies 0-7645-8958-X
- ✓ Salesforce.com For Dummies 0-470-04893-X
- ✓ Upgrading & Fixing Laptops For Dummies 0-7645-8959-8
- ✓ Word 2007 For Dummies 0-470-03658-3
- ✓ Quicken 2007 For Dummies 0-470-04600-7

## FOOD, HOME, GARDEN, HOBBIES, MUSIC & PETS

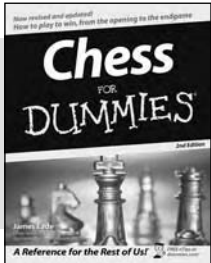

0-7645-8404-9

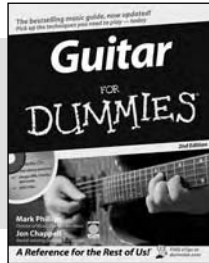

0-7645-9904-6

### Also available:

- ✓ Candy Making For Dummies 0-7645-9734-5
- ✓ Card Games For Dummies 0-7645-9910-0
- ✓ Crocheting For Dummies 0-7645-4151-X
- ✓ Dog Training For Dummies 0-7645-8418-9
- ✓ Healthy Carb Cookbook For Dummies 0-7645-8476-6
- ✓ Home Maintenance For Dummies 0-7645-5215-5
- ✓ Horses For Dummies 0-7645-9797-3
- ✓ Jewelry Making & Beading For Dummies 0-7645-2571-9
- ✓ Orchids For Dummies 0-7645-6759-4
- ✓ Puppies For Dummies 0-7645-5255-4
- ✓ Rock Guitar For Dummies 0-7645-5356-9
- ✓ Sewing For Dummies 0-7645-6847-7
- ✓ Singing For Dummies 0-7645-2475-5

## INTERNET & DIGITAL MEDIA

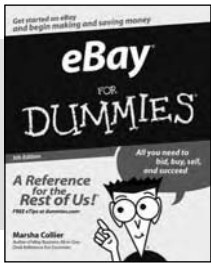

0-470-04529-9



0-470-04894-8

### Also available:

- ✓ Blogging For Dummies 0-471-77084-1
- ✓ Digital Photography For Dummies 0-7645-9802-3
- ✓ Digital Photography All-in-One Desk Reference For Dummies 0-470-03743-1
- ✓ Digital SLR Cameras and Photography For Dummies 0-7645-9803-1
- ✓ eBay Business All-in-One Desk Reference For Dummies 0-7645-8438-3
- ✓ HDTV For Dummies 0-470-09673-X
- ✓ Home Entertainment PCs For Dummies 0-470-05523-5
- ✓ MySpace For Dummies 0-470-09529-6
- ✓ Search Engine Optimization For Dummies 0-471-97998-8
- ✓ Skype For Dummies 0-470-04891-3
- ✓ The Internet For Dummies 0-7645-8996-2
- ✓ Wiring Your Digital Home For Dummies 0-471-91830-X

\* Separate Canadian edition also available

† Separate U.K. edition also available

Available wherever books are sold. For more information or to order direct: U.S. customers visit [www.dummies.com](http://www.dummies.com) or call 1-877-762-2974. U.K. customers visit [www.wileyurope.com](http://www.wileyurope.com) or call 0800 243407. Canadian customers visit [www.wiley.ca](http://www.wiley.ca) or call 1-800-567-4797.



## SPORTS, FITNESS, PARENTING, RELIGION & SPIRITUALITY

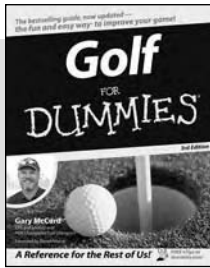

0-471-76871-5

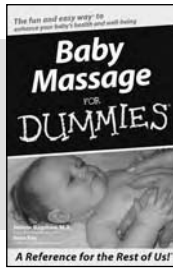

0-7645-7841-3

### Also available:

- ✓ Catholicism For Dummies 0-7645-5391-7
- ✓ Exercise Balls For Dummies 0-7645-5623-1
- ✓ Fitness For Dummies 0-7645-7851-0
- ✓ Football For Dummies 0-7645-3936-1
- ✓ Judaism For Dummies 0-7645-5299-6
- ✓ Potty Training For Dummies 0-7645-5417-4
- ✓ Buddhism For Dummies 0-7645-5359-3
- ✓ Pregnancy For Dummies 0-7645-4483-7 †
- ✓ Ten Minute Tone-Ups For Dummies 0-7645-7207-5
- ✓ NASCAR For Dummies 0-7645-7681-X
- ✓ Religion For Dummies 0-7645-5264-3
- ✓ Soccer For Dummies 0-7645-5229-5
- ✓ Women in the Bible For Dummies 0-7645-8475-8

## TRAVEL

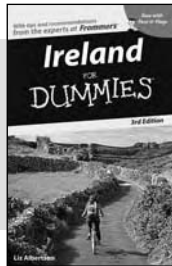

0-7645-7749-2

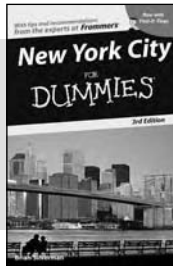

0-7645-6945-7

### Also available:

- ✓ Alaska For Dummies 0-7645-7746-8
- ✓ Cruise Vacations For Dummies 0-7645-6941-4
- ✓ England For Dummies 0-7645-4276-1
- ✓ Europe For Dummies 0-7645-7529-5
- ✓ Germany For Dummies 0-7645-7823-5
- ✓ Hawaii For Dummies 0-7645-7402-7
- ✓ Italy For Dummies 0-7645-7386-1
- ✓ Las Vegas For Dummies 0-7645-7382-9
- ✓ London For Dummies 0-7645-4277-X
- ✓ Paris For Dummies 0-7645-7630-5
- ✓ RV Vacations For Dummies 0-7645-4442-X
- ✓ Walt Disney World & Orlando For Dummies 0-7645-9660-8

## GRAPHICS, DESIGN & WEB DEVELOPMENT

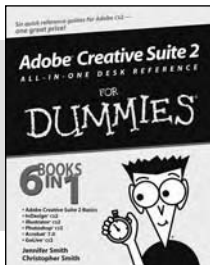

0-7645-8815-X

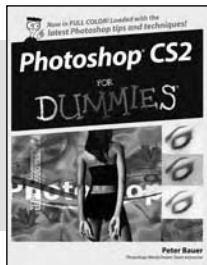

0-7645-9571-7

### Also available:

- ✓ 3D Game Animation For Dummies 0-7645-8789-7
- ✓ AutoCAD 2006 For Dummies 0-7645-8925-3
- ✓ Building a Web Site For Dummies 0-7645-7144-3
- ✓ Creating Web Pages For Dummies 0-470-08030-2
- ✓ Creating Web Pages All-in-One Desk Reference For Dummies 0-7645-4345-8
- ✓ Dreamweaver 8 For Dummies 0-7645-9649-7
- ✓ InDesign CS2 For Dummies 0-7645-9572-5
- ✓ Macromedia Flash 8 For Dummies 0-7645-9691-8
- ✓ Photoshop CS2 and Digital Photography For Dummies 0-7645-9580-6
- ✓ Photoshop Elements 4 For Dummies 0-471-77483-9
- ✓ Syndicating Web Sites with RSS Feeds For Dummies 0-7645-8848-6
- ✓ Yahoo! SiteBuilder For Dummies 0-7645-9800-7

## NETWORKING, SECURITY, PROGRAMMING & DATABASES

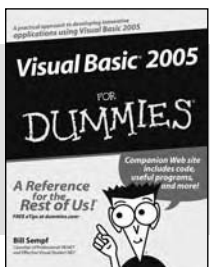

0-7645-7728-X

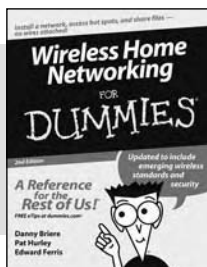

0-471-74940-0

### Also available:

- ✓ Access 2007 For Dummies 0-470-04612-0
- ✓ ASP.NET 2 For Dummies 0-7645-7907-X
- ✓ C# 2005 For Dummies 0-7645-9704-3
- ✓ Hacking For Dummies 0-470-05235-X
- ✓ Hacking Wireless Networks For Dummies 0-7645-9730-2
- ✓ Java For Dummies 0-470-08716-1
- ✓ Microsoft SQL Server 2005 For Dummies 0-7645-7755-7
- ✓ Networking All-in-One Desk Reference For Dummies 0-7645-9939-9
- ✓ Preventing Identity Theft For Dummies 0-7645-7336-5
- ✓ Telecom For Dummies 0-471-77085-X
- ✓ Visual Studio 2005 All-in-One Desk Reference For Dummies 0-7645-9775-2
- ✓ XML For Dummies 0-7645-8845-1



Bags are something a woman can never have enough of, and these three fulfill every need. Learn new techniques, such as felting, by crocheting the pink-striped tote, featured in Chapter 14, and the Tunisian afghan stitch as shown in the blue tweed bag in Chapter 13. The small pink suede pocket purse works up in an evening; you can find the pattern in Chapter 17.

This flirty denim-like skirt can go from school to a night out at the movies. Chapter 7 has all the details. The felted heart pin, crocheted separately, can be attached to a jacket, sweater, or even your backpack, while the beaded anklet is a fast and fun accessory to stitch. Find the designs for both in Chapter 17. The luggage tag will make your bag stand out from everyone else's. Find the directions in Chapter 15.

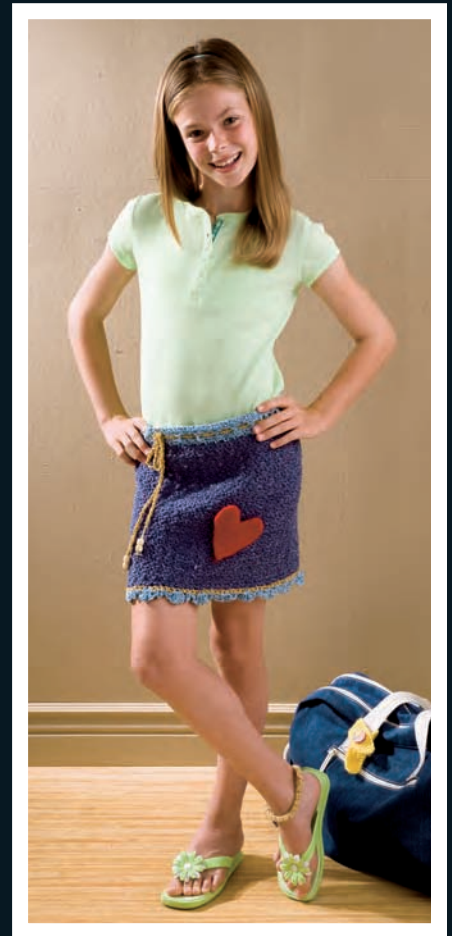

Pick a scarf, any scarf. The curlicue scarf is made by increasing stitches, which causes the length to curl, as the pattern in Chapter 6 describes. For a bold splash of black and white, crochet this textured scarf using only single crochet stitches; the yarn does the work for you. See Chapter 5 for the pattern. Set the mood with this unique black-and-blue scarf. It's really long, and no two will come out exactly the same due to the self-striping yarn used. Flip to Chapter 17 for instructions.

The springtime pullover, found in Chapter 12, is just what you need for cooler days. It's crocheted using a simple stitch pattern that creates a flexible but non-see-through fabric. You embellish the sweater with beads along the bottom edge and sleeves. Grab this self-striping drawstring bag, featured in Chapter 7, to hold your belongings, and off you go (pin optional).







A belt for every reason: Wear the beads-'n'-bows belt (top) around your waist or on your hips for a feminine touch; the pattern is in Chapter 9. Pair the beaded-fringe belt (middle) with your favorite jeans and T-shirt; it's featured in Chapter 6. The white belt, made from crossed double crochet stitches, goes with everything; whip this up from the pattern in Chapter 11.



This casual open-front vest is great for when it's a little cool outside but you don't need a full coat. The stitches and the shaping are easy; check out the pattern in Chapter 10.



Casual warmth describes this oversized shawl crocheted with a soft bouclé yarn. Start with a single stitch and increase your way up to the final width, and then add the edging with a contrasting color. Find this pattern in Chapter 6.





Fun and funky describes this wire-'n'-beads necklace. Pair it with the wire chain-link bracelet, and you've got a set no one else will be wearing. Find the necklace pattern in Chapter 14 and the wire bracelet pattern in Chapter 17.



Expand your stitch pattern knowledge while crocheting this stylish lacy bolero. You can find the pattern in Chapter 12.



Dress up a plain pair of jeans with this pocket patch for a fraction of the cost that you'd see in the stores. Crocheted with size 10 thread and basic square motifs, you can have a pair finished in no time. Turn to Chapter 15 for the instructions.



This unique scarf really brightens up a gloomy day. Crochet large loops to create the texture, and then add some pompoms for more fun. This pattern can be found in Chapter 11.



These practical potholders are something you can never have too many of. Worked in single crochet to create a tight, sturdy fabric, they're great for when you need to make something but don't have a lot of time. See Chapter 5 for the pattern.



Add a bold splash of color and design to cocktail time. Each coaster in this set is worked from a chart, carrying the yarn as you go. Turn to Chapter 15 for the pattern.

With good music, your favorite book, and a cold drink, you're set for a relaxing afternoon. Crochet this unique can-cozy by making a flat base and then working even in a spiral until the desired height is reached. The MP3 cover combines materials and stitch techniques to create a one-of-a-kind cover that will stand out. Lavender yarn and long stitches make for a bookmark reminiscent of a floor runner. All three of these projects can be found in Chapter 17. The purple bookmark is made using size 10 crochet thread and a simple shell stitch pattern. Turn to Chapter 15 for the details.



You can crochet countless items to use around the house. Some pictures deserve an extra-special frame, and this one made with fun fur yarn will do the trick, as found in Chapter 15. For the readers in your life, use filet crochet to create this one-of-a-kind bookmark. The instructions and chart are found in Chapter 13. So you know which drink is yours, mark your glass with this stemmed glass marker made from an earring hoop and crochet thread; see Chapter 15 for the instructions. The ever-useful basket is made with the untraditional crochet material, hemp cord; the instructions are in Chapter 14. Underneath it all is the diamond-shaped table runner. This design lets you hone your increasing and decreasing skills, so flip to Chapter 6 for instructions.





Show your love for baby by using filet crochet to make this heart valance to hang across the nursery windows. The pastel-colored blanket, worked in basic afghan stitch, will keep baby warm. You can find both patterns in Chapter 13.



Throw this super-soft pillow on your bed or sofa to add a splash of color or texture; turn to Chapter 10 for instructions. While resting your head, wrap yourself in this generously sized afghan for an extra dose of warmth; find the pattern in Chapter 5. And, not to leave out your feet, sink your toes into the softness of this striped throw rug made with chenille yarn; see Chapter 8 for the pattern.



Create your own crocheted bedding with this simple pillowcase edging using size 10 crochet thread. You can find the pattern along with the stitch diagram in Chapter 14. The chevron throw is made using a common wave stitch pattern and ultra-soft yarn. Find this pattern in Chapter 8.





Hats are a great way to practice crocheting in the round and shaping your designs. The two hats on the left are created from the identical pattern. A simple change in material and hook size creates different looks and sizes. You can find the instructions in Chapter 9. Adorn the hat with a crocheted rose, and you've got a whole new look. The pattern is in Chapter 15. The red velvet crusher hat involves increasing stitches and some more advanced shaping techniques, so turn to Chapter 7 for details. The denim cloche combines increasing stitches, shaping, color changes, and varying stitch patterns; find this design in Chapter 8. The striped scarf, also found in Chapter 8, uses a variety of textured yarns that makes the scarf look more complicated to stitch than it actually is. Crochet individual flowers with just two rounds to create the fun and funky flower-power belt; flip to Chapter 10 for the pattern.

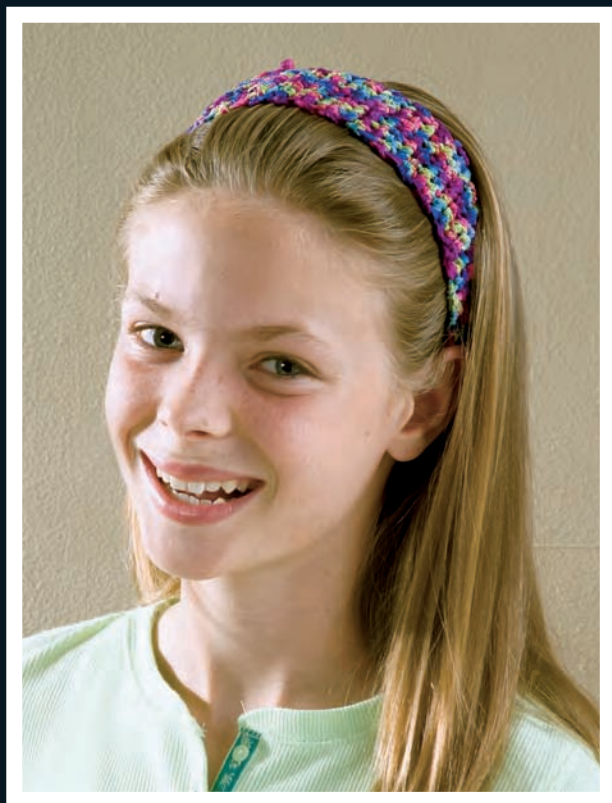

You'll find all the colors of the rainbow in this easy-to-crochet headband. Turn to Chapter 5 for this pattern, as well as instructions to create two additional headbands using different materials.

This classically styled newsboy beret is created by crocheting in the round, increasing and decreasing your stitches to create the shape; the pattern is in Chapter 7. Pair the beret with this nontraditional granny square scarf, and you've got a great combination. Turn to Chapter 14 for the pattern.







Dress it up or dress it down, this great little tank top goes anywhere. You crochet it with a basic shell stitch pattern and little shaping, so it's a perfect choice for a starter garment. See Chapter 12 for the pattern.



Wear this fur-trimmed jacket with a pair of black pants or skirt and you're ready for a night out on the town. Turn to Chapter 12 for instructions.



Wrap yourself in elegance with this sparkly, soft evening wrap. The yarn does all the work as you follow the simple stitch pattern found in Chapter 11.



The neutral color and easy stitch pattern make this design a must-have. Wear it over your shoulders as shown, or wrap it around your waist to make a fashion statement all your own. The pattern is featured in Chapter 11.

Camouflage is as popular as ever, so to crochet this military-style belt and be the envy of all your friends, flip to Chapter 17.



Keep warm and cozy this winter with this tunic sweater worked in vertical rows. The pattern in Chapter 12 has all the details. Add the colorful beads-'n'-bows scarf for an extra layer of warmth; the pattern can be found in Chapter 9.



Delight your friends by making this easy-to-stitch friendship bracelet for each of them. The bracelet can be worked up in an evening; see Chapter 15 for the instructions.



Whip up a great hair accessory in no time flat. The pattern in Chapter 15 gives you instructions for this scrunchy as well as others made with different materials.