

The Vampire Adept Bible

Notice:

The Vampire Religion requires that all followers refrain from any and all criminal acts as defined by their respective governments.

To be a Vampire, a follower of the Vampire Religion, you are expected to behave in a responsible and adult manner within society.

The Temple of the Vampire
will excommunicate any individual who fails to do so.

The Temple of the Vampire
will not be held responsible for the actions of anyone
who fails to behave in a legal and socially responsible manner.

The above statements are made not subject to our standard disclaimer
and can be relied upon as being factual and accurate.

The Vampire Adept Bible

Copyright © 1989 by the Temple of the Vampire.

No portion of this book may be reproduced, stored in a retrieval system, or transmitted, in any form or by any means, electronic, mechanical, photocopying, recording or otherwise without the written permission of the publisher. For information contact the Temple of the Vampire.

Published by the Temple of the Vampire.

Distributed by
Temple of the Vampire
P.O. Box 3582
Lacey, WA 98509 U.S.A.

Internet website
www.vampiretemple.com

Cover: *The Winged Skull of UR*, trademark logo
of the Temple of the Vampire.

Printed in the United States of America.

*Within lies fact and fancy,
truth and metaphor.
Discriminate
with care.*

Contents

What Is Truth?

The Four Dimensions of Experience

The Nine Gates and Angles

The Doctrine of Dreams



What is Truth?

We of the Temple are unique in many ways. We have abandoned identification with the human and embraced the role of the predator. We have rejected the irrational in human culture and skimmed the cream of humanity to replenish Our numbers over the long centuries. We have chosen to do much, try much and expect much.

Yet what truly sets the Vampire apart is a flexibility in belief. I know of no other body in history which says to the member, "Why settle for the mundane when stretching before you is the freedom of choice?" I know of no other because there is no other. We are unique.

The Dayside personality permits Our members to live "normal" lives within the human community. It is a fact that most of our members have kept the reality of the Temple a secret from the humans they work and play with for years. The Dayside is the physical foundation, the physical anchor, which roots Our members into the world as it is. The Dayside Vampire believes nothing. The Dayside Vampire is the complete skeptic, the materialist, the cynic. As a consequence, the Dayside Vampire is seldom if ever taken in by the merciless lies which rule the world of mortals. The Dayside Vampire sees through human foibles and does not hesitate to take the fullest advantage of human nature to prosper, dominate and survive. The Dayside Vampire has a rational plan for immortality through scientific technology and spurns with knowing scorn the make-believe heavens and hells of the human religions.

Yet We are not limited to only this side of Our nature for there is also the **Nightside**. During the day of brilliant sunlight and sharp contrasts, there is no room for the powers of darkness, the creeping, stealthy flow of ghostly beings in the night. Night is different from day. Thus, the **Nightside Vampire** embraces and develops the Powers of Darkness, communes with the Undead Gods, rises above the chains of a limited physical body and experiences the ecstasies of astral immortality and power.

Some members of the Temple are attracted by the brilliance of the **Dayside** to better their lot in life and join with those very few of this era who will achieve physical immortality in the flesh. Some members of the Temple are attracted by the **Nightside** to experience the thrill of Vampirism, flight, shape changing and the incomparable depth of the studies of true magic with Those Who Have Risen.

Yet, in time, most members find the greatest joy in the balance of these two perspectives. These are the members who overcome the limitations of a narrow single belief system. These are the ones who enjoy the pleasures of the moment and see that it is an unbroken bridge through eternity. These are the members who come to the Temple with respect, with curiosity, but most of all with the intense desire to have fun with their never-ending voyage.

If you have found yourself bound by your **Dayside** doubts, unbind yourself in the **Nightside**. If you have found yourself dominated by your yet unproven beliefs of the **Nightside**, entrench yourself in the firmness of the **Dayside**.

Both are real. Both have power. Both fall under Our sway!
Stay strong! Enjoy!

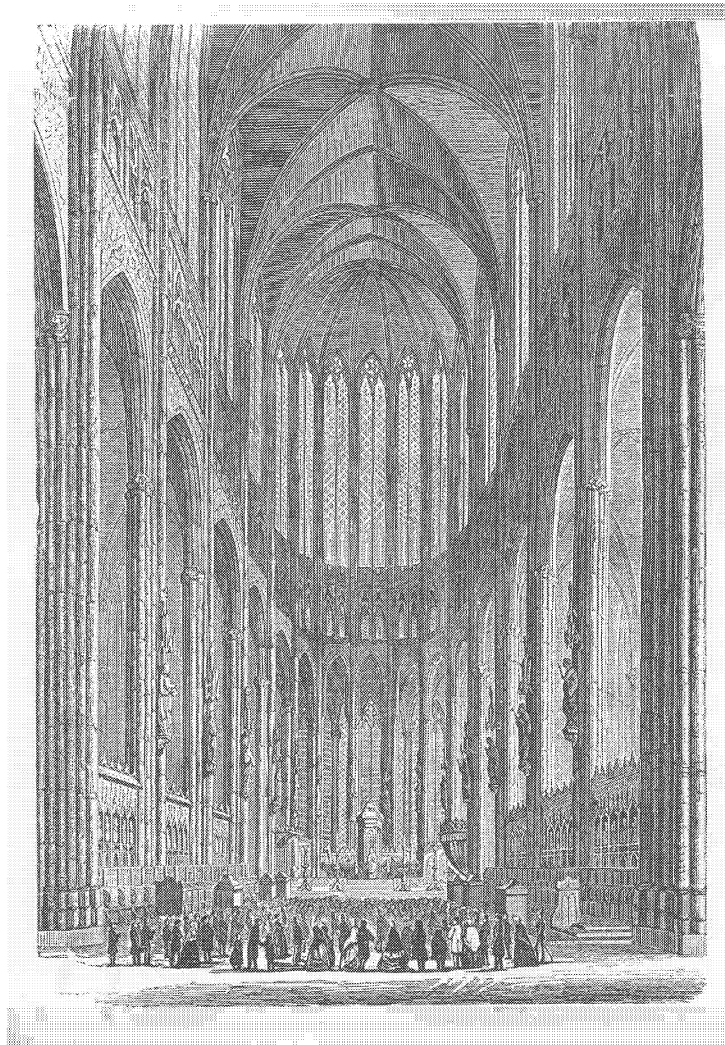

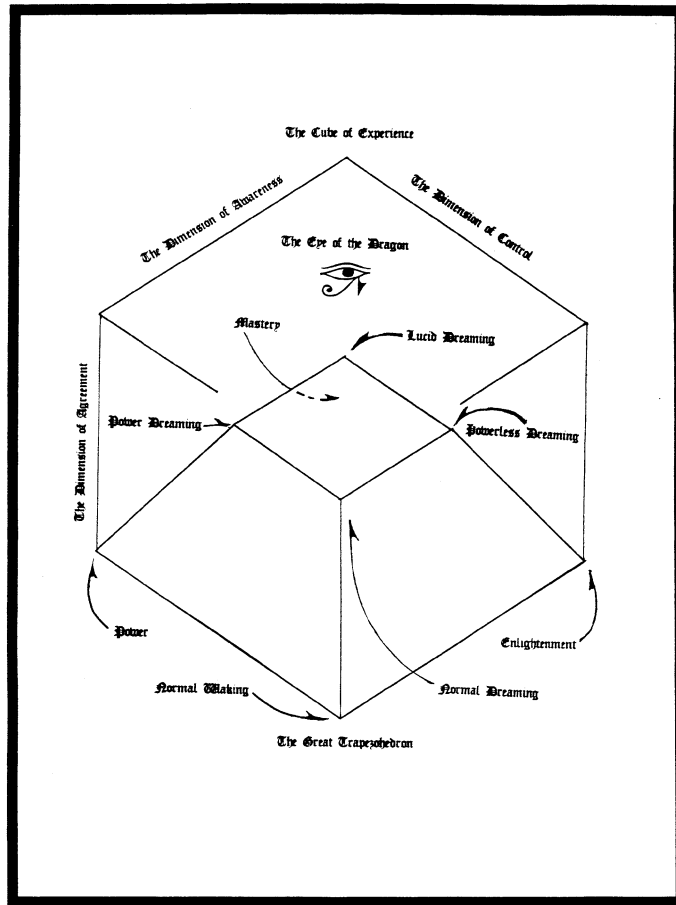

The Four Dimensions of Experience

The Dragon Speaks:

Envision now a cube of three dimensions. I shall name the vertical dimension "Agreement", the dimension of depth "Control", and the dimension of width "Awareness". Listen now as I reveal the secrets of the structure of the universe and place in your hands a Map of the Three Worlds.

The Dimension of Agreement

All is Belief

Agreement, the vertical dimension, is found in the realization that what living conscious minds agree upon as real, is and becomes real in experience.

Experience includes all experience. The self-deceived of the first world commonly divide mental experience from physical perception and altogether damn emotional experience to a limbo between the real and unreal.

All experience is real. The function of Agreement is to decide which of your kind can *perceive* what exists! If you see and hear a purring cat on a chair and ten other persons present in that same place see no cat but only an empty chair, you lack Agreement. The other ten would call your real experience an "hallucination". If everyone present can see and hear the cat, then your experience of the cat has Agreement and is considered "real" by others.

Abandon now this dogmatic prejudice of the blind fools of the World of Slavery! Agreement is the determiner of what the ignorant call "real". Again, I tell you *all* experience is real. What is, *is!*

If you were to photograph the chair, the cat would appear in the photograph if there was sufficient Agreement but would be absent from the picture without sufficient Agreement. The perceptual fabric of the tapestry of experience is determined by Agreement.

But, hold! Consider the situation in which *some* of those present were to see the cat while others did not! What happens in the presence of partial Agreement?

The answer to this question is found by any careful examination of your present world. Your deathist culture has worked to diligently ignore those aspects of your world which fall into partial Agreement. These exceptions, these legions of "anomalies" and "impossibilities" recorded daily and throughout the whole of your history, shatter the illusion of a fixed "reality" to any but the most obstinate.

Your "science", based upon the shadows of a dream reality, ignores the barrage of facts which demonstrate the truth of My words. Yet, even within the hallowed halls of the mausoleum of your science we find some who, realizing the truth, come forward to declare the error of their ways. Few, indeed, are those who will cast off their blindfolds and declare the light of day to exist!

For the foundation of Agreement is found in the psychology of the minds creating it! Discovering that most other persons in

that room denied seeing the cat, how many would also then "choose" to no longer see the cat? And how soon those still restrained within the World of Slavery then come to no longer be *capable* of perceiving even that which *has* Agreement!

As an animal sinking in quicksand thrashes wildly, dooming itself to destruction, the deceived of your world struggle with abandon to admit the fluid structure of experience and acknowledge the power of the dimension of Agreement.

How often, despite their struggles, the humans of your earth reduce the dimension of Agreement in what you call sleep, to move in a world of their own total creation called dreams? And again, how often in moving up the scale of Agreement following sleep, do these humans encounter glimpses of future events, the thoughts of others, the vision of people and objects and landscapes around them which they then condemn to the "unreality" of "hallucination"? And, even again, how often, when their "unreal" dreams probe to have Agreement and "reality" do these same fools purposefully work to forget these glaring exceptions to their false view of things?

Do you not know of those who have seen the deaths of others of your kind from a dream vision at the same moment? Have you not known of the Agreement that exists between those who die, those who sleep, and those who dream, with quick journeys down long star path tunnels, meeting with others whole and alive as you are?

Consider also the objects which fly in your heavens and are visible to some while invisible to others, all the while being tracked by your radar! Consider the marching millions of visions, apparitions and visitations to your earth across the

centuries. Consider the followers of the human religions of death who, almost weekly, find another appearance of their long-dead religious founder, god or saint.

And I tell you that all these are the creations of the minds of your race through unconscious Agreement! There are none of the other worlds who would remain in converse with such as the majority who inhabit your earth now, so know that all these are the creations of your own minds and a key to the secret of the Magic of Agreement!

Do you doubt my words? Then consider closely the messages given by your "alien visitors", "angels", "Madonnas", and others of the fairie creation of your own unconscious Agreement. Do these messages not duplicate the lies of your own death-worshipping religions? Do these "beings" not lead your masses on long journeys to mountain tops to be "rescued" at the predicted end of your world, only then to have nothing happen? And isn't it true that the same form of beings have come again and again while matching your machine technology stage for stage? Were there not chariots in the sky when there were chariots on earth and spacecraft in the heavens when there were spacecraft on earth?

Look and understand! Your race has chosen a path of self-destruction and death-worship and for millennia has talked to itself through projections of Agreement to find the "faith" to believe its own lies. Sacrifice your "faith" on the altar of your mind and know the truth! Agreement is that dimension which determines what exists in your mutual experience.

There is no other determiner of "reality"!

The Dimension of Control

All is Mind-Stuff

The ability to control the elements of experience in accordance with your conscious desire is the dimension of Control.

When you choose to close or open your hand and do so, this is an example of Control familiar to you. Moving the voluntary muscles of your body, ordinary walking, stretching, blinking your eyes, breathing, talking, and so forth are all common examples of Control.

Extending your Control over most of your experience includes all of the magical powers which your people think of when they hear the word "magic". When you extend your ability to move your finger so that you can move a paperweight without physical contact, this is called psychokinesis, or mind-over-matter.

When you extend your ability to see the paperweight in front of you so that you can see through a wall to a book on a desk beyond that wall, this is called clairvoyance or remote viewing. When you extend your ability to talk with someone miles away without a telephone, this is called telepathy or mind-reading.

All of these are simple extensions of your common powers of Control over your environment. You treat these common skills as if they were nothing, yet, in actuality, the mystery of how you can move your hand once you mentally choose to do so is no better understood by you than the demonstrated ability of some who have moved objects without touching them.

On one level, the whole universe of experience is made up of a form of mental substance or "mind-stuff", what the most ancient yogi rishis of India called "prakriti".

So it is that your mind does not only receive information through your senses about the universe around you but also your mind can project changes upon the universe because the basic nature of reality is mental.

Everything that exists in experience is made up from this mental substance and therefore your mind can directly influence the shape and behavior of the universe around you.

Imagine for a moment that you were outdoors at night when there was a thick fog drifting from the ground up to about the level of your waist. The fog has a kind of shape to it as it flows over parked cars, fences and bushes, and as air currents move it slowly about.

The essence of this low-hanging blanket of fog would be air and, because you can move air, you could move the fog around you by simply waving the air above it down towards this white mass with your hand.

In the same way, if the *appearance* of the physical universe were represented by that blanket of fog, the *air* would represent the mind-stuff. Because you can and do Control your mind-stuff, just as you can and do move air, your mind can directly influence the shape and behavior of the physical universe, just like that fog.

The Dimension of Awareness

All Is A Dream

The dimension of width is the Awareness that all of experience is a mental construction, just like a dream. The Magic of Awareness is the supreme magic and is what I call My Dragon Magic.

Know first that this is *not* a denial of the objectivity of reality! It is the dimension of Agreement that determines objectivity. Rather, know that Awareness is determined by the degree of lucidity on your part concerning the fact that the universe is a dreamlike construction following the Nine Laws of Magic.

And what is true of a dream? In your dreams there are two truths. First, anything can happen in a dream. Second, what you expect tends to happen in a dream.

What can you not do in a dream? What can you not experience? Dreams are the gateway to infinite joy and eternal power. And constant is My prodding to remind even the most dead of your world of the truth of the dimension of Awareness.

Yet what is required to awaken in the Dream of your experience? How may you rise as a Dream Master and cause your power of desire to mold the whole of your life experience at will?

Understand that I shall give to you the tools to forge this Awareness and to seize this power which sleeps within you even as you read these words. And with the Magic of Awareness all, yes, all possibilities will become open to you

and you shall then see your true position and understand that, in truth, all experience exists to serve the Experienter!

Now there is an additional realization you need to have and this thought, new to your mind, can open wide the gate to this World of Power. When you dream, you most usually know not that you are dreaming. Later, when awake, you compare the discrepancies between your waking experience and the dream experience.

Yet have you not been certain you were awake only later to discover you were actually still dreaming? The early morning sometimes holds the dream of rising, preparing for the day, going through many of your routine behaviors and then awakening from that dream as the alarm clock brashly bursts that world.

What you need to experience and then understand is the truth of the Dream of Power. The Dream of Power is that dream in which you awaken without disrupting the dream. Known also as the lucid dream, the Dream of Power is that experience which you seek as a true magician.

When you have walked the Third World through the Dream of Power you will come to know the truth of this statement I now say to you:

You cannot ever know with certainty when you are "awake".

You can only verify when you are dreaming.

You can only discover with certainty that *this* is a dream.

You can never verify any other reality.

The Dimension of the Dragon

Being is not Experience

Now imagine a single, mathematical point existing *outside* the cube we have described with the dimensions of Agreement, Control and Awareness.

This single point is outside of all experience represented by the cube. This point is outside all time and space represented by the cube.

Such a point is both finite and infinite and the qualities of experience do not apply.

This point, this fourth dimension, is your innermost Self, the Observer, and is Myself, the Dragon.

I, the Dragon, am the necessary anchor to give meaning to your experience when you rise to majesty in the World of Power.

Without me, you become no more than a mindless mystic, merged in the oneness of the cube of experience.

It is because of Me that your Dream of Power does not fragment your Will. It is because of My Essence that the game of experience is ever fresh, ever renewed within you.

Never can you know directly the Dragon, for I am Being. Your Innermost Self is not to be experienced but to Be!

As teeth do not themselves bite, not the eye upon its own orb
gaze, so too I can only be known in the mirror of the mind by
My perpetual absence as the experienced and Presence as the
Observer.

Know that without Me there would be no consciousness.

Yet know also that if you would come to believe that I am
found as an experience, then you have been deluded.

I am your Self!

To think you see Me is to demonstrate that you only see
another!

I am the Black Flame which casts the light of consciousness
but is Itself never to be seen.

May you read and understand!

Tat tvam asi!

bnA rEo kA can A!

There is no other!

The Nine Gates and Angles

Why This Information Is Important

When a new idea is presented to the mind, it requires effort to understand it. What you are about to read is not easy for most individuals to grasp, but it is extremely useful.

Altered states of consciousness can potentially give you access to different powers and understandings. Throughout recorded history different so-called occult or metaphysical or mystery schools have offered fuzzy and contradictory explanations for applying their techniques as well as selecting and achieving their goals. Consequently, the student would commonly find himself lost, pursuing dead-end directions sometimes for decades and often not even certain if the goal offered was truly desirable to achieve. The student often discovered that where he was headed was not where he wanted to end up.

There will be no such confusions here.

While what follows is sometimes complex, you will find, if you make the necessary effort, that it is understandable and very, very useful.

After digesting this information you will be able to listen to descriptions of specific altered states and not only understand exactly what the individual experienced but precisely what you would need to do to duplicate that experience. You will also know if it is an experience you wish to achieve or if it would take you in the wrong direction.

What follows is a road map, compass and guidebook.

Use these tools well and never be lost again!

Caution!

All of the terms and expressions used herein have been called by many other names and titles throughout history.

Be especially careful to not confuse corrupted non-Temple explanations and schools of thought with the realities delineated here.

There is no public model extant which has a direct one-to-one correspondence to these Highest Teachings regarding the nature and manipulation of reality.

In other words, do not believe you understand these ideas in advance of what you are about to read.

The following is not a restatement of any other occult or metaphysical teaching available in the human world.

May you read and understand!

The Nine Gates To All Possible Worlds

The three dimensions of all possible experience (Agreement, Control and Awareness) form the Great Pyramid, the Temple of the Nine Angles and the Nine Gates.

The base of the pyramid is the Plane of Agreement where (potentially) all sentient beings may agree with each other regarding the presence of the same experiences.

The next higher level, where there is minimum Agreement, is the Plane of Dreams, where (potentially) there is no sharing of agreed-upon experience with any other sentient being.

The peak of the pyramid is the Eye of the Dragon, seemingly a single point of awareness but, in actuality, an infinite plane beyond experience, the presence of which makes all other experiences possible.

Each corner of the truncated pyramid (known also as the Great Trapezohedron) as well as the pinnacle is a Gate and a Destination and an example of an ideal state of consciousness.

In the Plane of Agreement the four Gates are:
Normal Making, Power, Enlightenment and Mastery.

In the Plane of Dreams the four Gates are:
Normal Dreaming, Power Dreaming, Powerless Dreaming
and Lucid Dreaming.

The Ninth Gate is the Gate of the Dragon.

If we assign a weight of either "one" or "zero" to each of the Nine Gates such that "one" represents 100% of the potential of any dimension and "zero" represents 0% of the potential of any dimension, we can generate a Table of Gate Relationships. (See table below).

Table of Gate Relationships

	Normal Waking	Power	Enlightenment	Mastery	Normal Dreaming	Power Dreaming	Lucid Dreaming	Powerless Dreaming
Agreement	1	1	1	1	0	0	0	0
Control	0	1	0	1	0	1	1	0
Awareness	0	0	1	1	0	0	1	1
Total	1	2	2	3	0	1	2	1

If we total the weights for each Gate, then the higher the total, the more desirable the Gate. The Gate of Mastery is the most desirable with a score of "3."

The Gates of Power, Enlightenment and Lucid Dreaming are next most desirable with scores of "2" each.

The Gates of Normal Waking, Power Dreaming and Powerless Dreaming are less desirable with scores of "1" each.

Least desirable is the Gate of Normal Dreaming with a score of "0."

These values make a great deal of sense when we examine the quality of the content of experience possible at each Gate.

For example, the Gate of Mastery is the most highly desired since in that condition you have complete power over the elements of reality (Control), you are fully cognizant of the fact that the universe of experience is a dream (Awareness), and you are capable of demonstrating these facts to anyone else (Agreement).

This Gate is superior to the Gate of Power because while you may be able to perform "miracles" that others recognize as "real" at the Gate of Power, you lack the stability to remain very long in that condition because you do not understand the true source of your power to control the elements of reality.

You lack the Awareness that because all is a dream, you, as the dreamer, are the ultimate source of the control of the dream.

The Gate of Mastery is also superior to the Gate of Enlightenment because to fully realize how all experience is a dream (we usually refer to this as "the Dream" with a capital "D") may be emotionally liberating (as we will discuss regarding the condition called "nirvana"), it lacks control over the elements of reality.

You may recognize that all is a Dream, but you may retain a desire to change the Dream to suit you and find that this ability is lacking.

This frustration is absent in the Gate of Mastery.

The Nine Angles

Pathways Through To Other Worlds

When the great truncated pyramid is viewed from above (from the viewpoint of the Eye of the Dragon) it is possible to trace eight different angles or paths of experience which a sentient being may follow when beginning from the experience of normal waking.

One of these leads to normal dreaming.

Two of these lead to Power.

Two of these lead to Enlightenment.

Three of these lead to Mastery.

The Ninth is embodied in the quality of the infinite which is the Eye of the Dragon Itself.

The sigils used to designate each Angle or Pathway consist of a small circle, indicating the starting position (state of consciousness) on the Map of All Worlds.

The line connected to that circle follows the edges of the Grand Trapezohedron indicating which states of consciousness are passed through on the journey to the end condition.

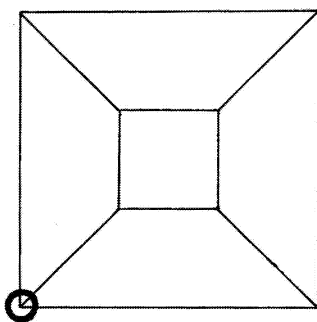

The Path of Normal Waking

The sigil for normal waking is represented only as a small circle with no projecting lines as we consider the Gate of Normal Waking to be a starting point from which any Path may begin. In a sense it represents the "zero" state, the beginning, the Alpha position.

Know that while many believe that they are in the normal waking state, this is actually a rare achievement because this Gate requires absolute Agreement. In truth, most sentient beings in the normal human state "float" between the Gates of Normal Waking and Normal Dreaming.

There is even a biorhythmic cycle of losing Agreement approximately every ninety minutes or so. In normal dreaming this is usually accompanied by rapid eye movement (REM) and it can be observed that the normal human being

will evince REM approximately every ninety minutes even while supposedly wide awake.

The implications of this for human manipulation become immediately evident. If one were to desire to influence another it would be a very wise step to spend at least ninety minutes in their presence and become alert to the subtle presence of rapid eye movement, indicating that there is a loss of Agreement. At this time, gentle suggestions loosely veiled as normal conversation can produce often profound hypnotic effects.

Conversely, if one were to wish to perform an act of reality manipulation in the presence of another, waiting for the cyclic presence of REM would make the operation much easier.

Along this line, it should also be remembered that it is possible to induce REM through the phenomena known as "driving." All that is required here is to recognize that the specific rhythms of the early sleep stages can be communicated to another in many ways such that the other person will begin to respond and produce the same REM rhythms.

A popular example of this can be found in the cinematic works of Frank Langella. Observe how he will cause his eyes to "shudder" left to right while gazing into the camera toward his audience. Such behavior can "drive" a response from the observer. Avoiding eyestrain, there are numerous other means to communicate this effect to include sound (music) rhythms, physical vibrations, the play of shadows over light, etc. Experimentation with these procedures will produce results.

Again, most human beings believe that they are fully awake and the truth is, the ideal condition of Normal Waking is actually

far from normal and requires enormous effort to touch upon. It is for this reason that groups of human beings will form irrational mobs under the correct circumstances.

The varying condition of semi-wakefulness of each individual member, when massed together behind some focused cause (as seen in lynch mobs or violent political rallies, for example), produces an averaged lessened level of Agreement as the mob moves further up the scale toward dreaming.

To form and control a mob relies upon primarily the same principles for "driving" RFA in an individual. In this case, however, the fact that in any sizable group of people there will almost certainly be a few individuals already in the RFA state, enables the manipulating leader to simply need to raise the emotional focus through properly impactful voice tonality and gestures.

Finally, for some further evidence of the false sense of wakefulness self-ascribed by most humans, consider the failure of witnesses to crimes to be able to produce matching descriptions of the most simple crime scenes they have witnessed.

Understand that the average human being is rarely awake with a high degree of Agreement. Most commonly, the average human being walks through a fog of semi-consciousness, head-stooped, staring stupidly at his feet and he trudges forward all the while believing he is the king of creation and the total master of his fate.

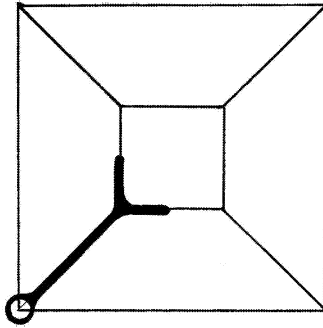

The Path of Normal Dreaming

The sigil or Angle for normal dreaming begins (as do all the sigils or Angles) at normal waking with a small circle and then climbs along the Southwest edge of the Grand Trapezohedron. At the Gate of Normal Dreaming, the potential paths from that Gate are represented by the two branching lines giving the sigil the appearance of a "U" with a small circle at its base.

Ideal Normal Dreaming is lacking in any Agreement, Awareness or Control. As is the case for these more mundane Gates, achieving the ideal is most unusual.

It is far more common for the human to range up and down the Southwest edge, gaining and losing Agreement, in the course of sleeping and dreaming. Thus there is always the opportunity for the individual to share dreams with others.

This Angle is known as the Path of the Slaves since this Path is where most human beings spend their lives, ignorant of the possibilities surrounding them.

Those remaining upon this vector are easily manipulated as they deny the possibility that dreams might contain the presence of other entities.

Such entities entering the dream state of this Angle can exert enormous power over the thinking and actions of the dreamer.

As it is written in the Shurpu Kishpu, "The Dreamers Eat The Sleepers."

The Gate of Normal Dreaming rests in isolation from the interplay with other sentient beings at the ideal level only.

All along this Path, everywhere below this Gate on this Path, the human is in illusion, believing either he is awake or, with some small Eastward motion toward Awareness, believing he is "only" dreaming.

This is why this Path is the Path of the Slaves - those upon it are enslaved in ignorance.

This Vector is the first leg in the journey of three other Pathways, as the Gate of Normal Dreaming is an important Gate to be passed through in traveling to many Higher Gates.

The key is to not stay there but to press on.

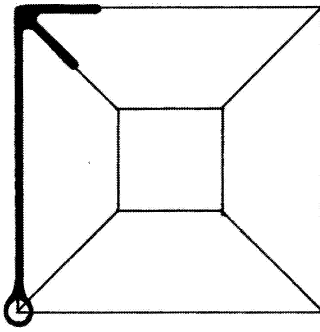

The Path of Power

This Angle is a direct assault upon one's effort to gain Control. This is the direct Path of magic. Beginning in Normal Making, the individual moves directly North. There is no need for losing Agreement nor dreaming.

To achieve this requires almost always a set of beliefs that enables one to gain Control. For example, one might hold some of the classic beliefs of magic. You might suppose that the principles of contagion and sympathy are universal fundamentals. Thus if you wished to gain control over the position of a mountain, you might take a small stone from that mountain and, placing it upon a map where the mountain is located, move the stone. With sufficient movement in the direction of Control, the mountain itself would begin to move along the same path.

The difficulty in pursuing the Path of Power is to gain sufficient success in lesser efforts to build up your belief in higher efforts.

As Control is a dimension of consciousness, your expectations must be such that you can accept the reality of such a Vector.

Thus the would-be magic user who tries to create a thunderstorm to end a drought can only move that far along the dimension of Control if he has had much success with lesser levels of Control, such as making small clouds appear or disappear.

The would-be magic user must be able to divert his judgment from failures while cataloging successes in order to amass enough success to come to expect more of the same.

This can often pose a problem as the magic user may come to feel he is only fooling himself and making excuses for failures. When this cycle of self-doubt begins, it is most difficult to undo.

An additional problem with the Path of Power is that it operates with a high degree of Agreement throughout. This means that from the beginning, the follower of this Path must produce results which are verifiable by others.

Since the vast majority of humanity deny that reality can be molded or altered, the follower of this Path finds himself subjected to the most intense social skepticism.

Thus it is most wise to conceal your intentions and efforts from the prying eyes of the masses when following this path.

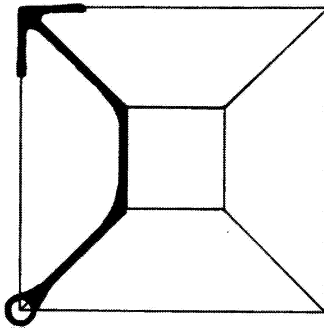

The Path of the Shaman

This is the second Angle of Power leading to the Gate of Power. This is the traditional dream or trance path to Power. The individual enters the dream state, reducing his Agreement but then Wills that he should possess power, moving northward. The traveler lacks Awareness and thus cannot rely upon the fact that he is dreaming as a lever to move North increasing control. Instead, there are several clever strategies he can follow to achieve this end.

The use of personal flying (as in the time-tested method of "Flying the Dragon") promotes Northern motion once in the Plane of Dreams. As the traveler enters sleep practicing flight, he transitions into flying dreams. To fly is to possess considerable Control and thus the traveler moves smoothly northward.

Another tactic, often utilized by the traditional shaman, is to enter "trance", which is to say, to move toward the Plane of Dreams while retaining the idea that it is not a dream he enters, but a parallel world such as an underworld or heavenly world.

By choosing therefore to believe that it is not Agreement which has lessened but a magical distance traveled to a numinous world, the traveler increases Control. He does this by assuming that he may perform deeds in this other world which are otherwise denied to him on earth because of the power of the place, rather than any personal power he may have exerted.

In either case, the traveler then completes this Angle by reacquiring Agreement. For the shaman this consists of often finding and possessing some element of the "higher world" he believes he has entered, and exiting his trance.

In the case of a healing, for example, the shaman might have entered trance, found an "animal of power," and then captured and clasped this creature to his bosom while returning from his trance state. At that point he might believe he has absorbed the Lifeforce of the "power animal" and will then go to his patient and breathe out the Lifeforce into the inhaling breath of the patient.

Examples of this are found in the traditional shamanistic practice of finding and bringing back to the Gate of Normal Making this "power" animal or object. In a poor reflection of true Vampirism, the shaman will "inhale" the power animal or object into his body and then, upon returning from his "higher world", will exhale the power into some material object or person to work his magic.

The Vampire will tend to utilize Flying the Dragon and upon entering dreams of flying will gather Agreement by expecting to enter the out-of-body experience.

Thus the Vampire will find that he transitions from a dream of flying to discovering himself, perhaps in his bedroom, but floating out-of-body above his bed.

To increase Agreement at this stage is to move to complete the ideal of this Angle.

This can often be accomplished by means of the Lifeforce approach.

Once out-of-body, the Vampire can further solidify his astral body by drawing more Lifeforce from his physical in the same manner that he mightampirize a victim.

Care should be taken to not approach too closely to the physical as unconscious mechanisms tend then to terminate the experience.

Again this Angle lacks Awareness and is somewhat limited in terms of its ultimate potentials.

The tendency is for the traveler to attempt to classify the experiences he has as more or less "real" rather than to see all of this as a measure of Agreement alone.

The advantage to this approach is the ease with which the traveler can enter the Gate of Power through the pattern of nightly dreaming.

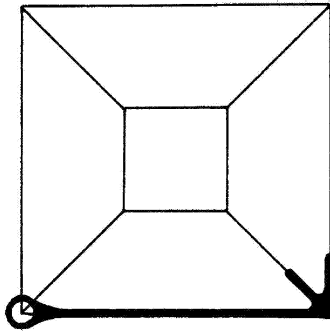

The Path of Illumination

Known commonly as "enlightenment" or mokṣha or nirvāna, the Gate of Knowledge can be entered without altering the degree of Agreement experienced. This Angle passes due East from normal wakefulness to the condition in which one realizes that all is a Dream.

There are many, many techniques to travel this Angle. Entire schools of discipline have been devoted to single approaches. All three major versions of Buddhism were originally only specific systematic approaches to moving toward the Gate of Knowledge. Every world religion stemmed from a core teaching devoted to motion along this Angle, though quickly became redefined as social institutions for the proper control of human beings instead.

The most direct method for passage to the East on this Angle is to constantly choose to remain behind the eyes while treating all of experience as a dream world. Constant application of the deidentification process is thus a motive power to the East.

Entering the Gate of Knowledge as a pure goal still denies the traveler any significant Control over his experience. This is because the traveler comes to feel that in the absence of any "objective" reality, all action becomes meaningless. In a dream there are no others to impress, protect, conquer not interact with.

Thus social functions lose meaning. In a dream no creation has meaning as it is only a dream. Thus all productivity and creation drops away. In a dream there is only isolation and emptiness. This condition is known in the Western traditions as "the dark night of the soul."

This trap of apathy and lack of meaning occurs because the Self, the Dragon, is absent in the awareness of the traveler. The traditional mystic achieving this Gate, will often be martyred or destroyed by the high Agreement around him, despite his personal certainty that all is a dream. From such failures of development have come the founders of many world religions.

It is rare for the Vampire to remain long in this Gate for his Awareness of the Dragon is the most common technique for movement along the Dimension of increased Awareness. The Vampire carries within his mind the duality of the Self and the Worlds.

Thus he avoids the dark night.

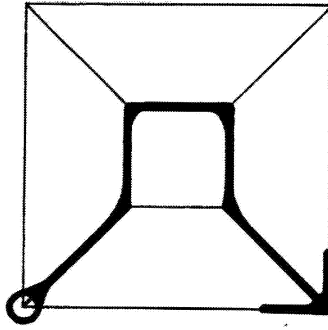

The Hell Path to Knowledge

This Angle is a near miss to the gate of Mastery and leads for short periods to the Gate of False Making also known as the Hell Worlds.

Following the Path of the Shaman, reaching the Gate of Dreaming Power, the traveler rouses himself to question the pure objectivity of his experience. He wonders if he might not be dreaming and thus moves East, realizing that this is so. This awakening in the dream leads him to the Gate of Lucid Dreaming, one step removed from Mastery.

Because the categorization of "dream" versus "reality" is false, the traveler may decide that the "lucid dream" has ended and that he has awakened in his normal waking world of mundane

consciousness. Then terror strikes as nightmarish experiences upset his usually secure "world."

The traveler lacks any real control over these experiences and will usually believe that he is "trapped" in a dream. This condition is commonly known as the false waking.

The traveler believes he has awoken from his dreams but then his bedroom evidences powerful dreamlike changes which can be terrifying to the uninitiated.

The avoidance of the Hell Worlds relies upon understanding that all experience is real. Thus the false dichotomy between "dreams" and "reality" is dropped and the experiences of the Gate of False Waking are only a momentary recognition that one has lost Control while retaining Awareness.

The passage out of this unpleasant condition can be swift unless fed by ignorant fears. These teachings are intended to help you avoid such ignorance.

One practical strategy for release from the bodily paralysis which often accompanies entrance to this Gate, is to concentrate your attentions upon physically moving a single finger on your hand.

This will almost always cause an immediate descent to Normal Waking Consciousness as the focused Will to move a specific muscle group concentrates and gathers Agreement, forcing the traveler to descend into greater Agreement.

Thus the Gate is passed.

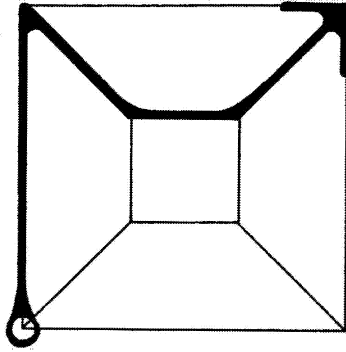

The Path of the Magician

This first Angle of Mastery is achieved by following the Path of Power, entering the Gate of Power and then remembering to question the reality of it all. Thus the traveler comes to exert direct Control over the Plane of Agreement but then rises directly toward the Dream Plane to question himself, "Could all this be a Dream?" From here the traveler enters the Gate of Lucid Dreaming and then, by Willing his experience to conform to the Plane of Agreement, retains all three: Agreement, Control and Awareness.

A more specific example of this Angle would be the traveler who, by means of the Path of Power, causes a "magical event" to happen on the Plane of Agreement. Immediately thereafter, he enters a trance state and rises to the Dream Plane and reminds himself to remember that he is dreaming, thus

achieving the gate of Lucid Dreaming. Then he exerts his Control to cause his dream state to conform to the appearance of his normal waking. He gathers Agreement and achieves the Gate of Mastery.

For example, the traveler might cause a lightning bolt to strike a particular spot in an open field.

He accomplishes this by means of the Path of Power and his many experiences of seeing his Will cause direct change in the world.

The shock of the power of his causing the thunderbolt might, to others, seem to knock him senseless or they see the magician fall into a swoon following his act of Power.

In that state of trance, the magician focuses his attention on the idea that he is dreaming and enters the Gate of Lucid Dreaming. Then, as the final act, he causes his dream to conform to the place in the open field where he just caused a lightning strike.

As his dream gathers Agreement, he enters the Gate of Mastery. Suddenly to all on that field, the magician can perform in their presence all that he could perform in his lucid dream. He has attained, for a time, the Gate of Mastery.

This is a difficult path for most. It requires nimble thought and action. The very belief systems employed to enter the Gate of Power must then be abandoned in the face of a greater achievement, the Gate of Mastery.

It can be followed but is not the easiest of paths.

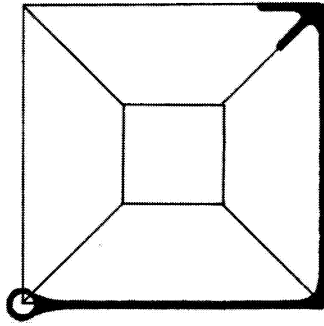

The Path of Will

Another difficult Angle to Mastery is this Vector which requires one to follow the path of Illumination and then turn North by force of Will to achieve the Gate of Mastery.

This requires an almost superhuman effort to overcome the most powerful of obstacles, certainty of futility. Having entered the Gate of Illumination, the traveler is convinced that all is a dream and nothing carries importance over anything else. Life and death, the same. Existence and nonexistence, the same.

Yet, the rare one will exert his Will despite all this and seek to express Control over his experience. Despite lack of meaning, he acts. Despite lack of motive, he acts.

Rare is the one who has moved far on this Path to Mastery for the Gate of Illumination is a realm far more alluring than the mere Dream Sharing of mortals.

Fortunately, most entering this Gate remain but a brief time and then leave, carried by the Vortices, the innate flow of motion in the Great Trapezohedron which is forever clockwise when viewed from the Eye of the Dragon.

From those few who have bridged this gap we find the saints and yogis who rise in miraculous power and perform deeds of apparent supernatural force.

So too we see why in their words and writings the use of such powers are condemned as leading one astray from the Gate of Illumination.

One manner for the traveler to go North from Illumination is to fix in his mind an obligation to the One Who transcends the Dream, the Dragon.

For it is the Will of the Dragon that the traveler should enter the Gate of Mastery.

For those who will dedicate themselves to the Great Dragon there remains the urge to go North and to escape from the Dark Night of the Soul.

Without this urge, the traveler is lost.

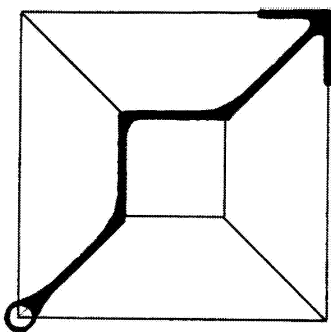

The Path of the Dragon

Herein we see the Angle leading to Mastery, easiest to walk, easiest to follow, most sure of success, best in all ways.

Rising to the Plane of Dreams while Flying the Dragon, the traveler gains Control and with increased Control gathers Awareness, entering the Gate of Lucid Dreams.

There he molds the elements of his experience to conform to his normal waking in the effort toward achieving the out-of-body experience, and thus settles down within the gate of Mastery.

How similar are the last steps to the difficult path of the Magician, yet lacking the troubles of conflicting belief systems.

Here the traveler need only use the natural condition of dreams to rise to Power, Awareness and then Mastery.

See also how the traveler rises toward the Eye of the Dragon and then, awash in Its Vision, finally descends, wrapping himself in Agreement, entering the Gate of Mastery.

This "H" shaped Angle is also the Path of Those Who Have Risen and Walk the Night Skies.

Once this Path has been walked, the way is remembered ever after.

Mastery then remains a Gate to enter and reenter. Mastery is not a final state but an ever-to-be-returned-to destination.

At the Gate of Mastery, there is only the need to gather more and more Agreement.

For here is the Gate that leads to the Other Gates, so long closed to the Body of the Blood, the Family of the Undead Gods.

The individual here may skip from body to body, thus finding a special immortality.

Yet here too the dedicated traveler can discover the Gates of the Ancient Times and help prepare the way beyond the limits of even Mastery.

May you read and understand!

The Doctrine of Dreams

The World is a Dream, And I am the Dreamer.
To Awake in the Dream Is the Purpose of Life.

The Dreamer Awake Is the Human Enlightened,
A Master of Power Beyond mortal strife.

I know now the reason The Dream exists truly.
The Dream serves the Dreamer For Time without end.

To Awake in the Dream Is the True Purpose only.
To awake from the Dream Is yet dreaming again.

And the thing men call death Is only illusion.
For dying is only To Dream once again.

And the dead Dreamer knows not The fact of the matter,
And seeking the Truth Finds only a Dream.

And all of man's gods And all of his heavens
And demons and hells Are not what they seem.

Yet the Dreamer Awake Rises high above all these;
The Founder, the Maker, The One Who Can See.

And all of the records Of time past forever
Are moment to moment In Dreams yet to be.

For time is illusion Spun out of the moment
Separate always From the Truth that is One.

The future and past Exist only by moments
And are only Dream Futures, Dream Pasts all alone.

And all that can Be Exists just as illusion,
The illusion created by T J A M A T, The One.

And I am the Dreamer Who makes the Worlds ever,
And can never fail To Dream Dreams anew.

And My Purpose forever Is always to Gather
My Forces for Knowing that this fact is true:

That the Worlds of My Dreaming Exist only to serve Me,
I am the Master, The Source of It All.

And all Power falls under My Choices of Wishing,
All Dreamers move closer To hearing the Call.

And this is My Promise: to Remember the Dragon,
The Dreamer, My True Self, The Source of It All.

And I promise most truly To Awaken all Others
To the Truth of the Dreamer To Hear the True Call.

Then All Worlds shall be The Places of Wonder
And Joy, Love and Power As each one of Us still

Will Gather the Power As the Dreamers Awaken
And manifest all In accord with My Will.

And True Power is Mine And carries My Will
As I Stir and Awaken To My Inner Call.

For always Behind All the Dreams of My Dreaming
There Stands the True Essence, My Self Knowing All.

And this Self is the Dragon, the Mother, the Founder,
The True God Who lives at the Source of It All.

And this Source is Forever Awake to the Truth
That All Is A Dream, And the Dreamer is Free.

And Remembering always, The Truth of My Being
causes My Being To Now Remind Me:

The World is a Dream And I am the Dreamer
To Awake in the Dream Is True Birth from the Womb

And My Inner Self always Awake to this Truth
Grants all of My wishes By Remembering !

HAA !



242. Final page, "Finis coronat" (the end crowns [the work]). From Jacob Cats' autobiographical poem *An Eighty-Two-Year-Long Life*, published by Jan van der Deyster, Leyden, 1732.

*Without lies fact and fancy,
truth and metaphor.
Discriminate
with care.*