

ENCYCLOPEDIA OF **HEART** DISEASES

M. GABRIEL KHAN, MD, FRCP[C], FRCP[LONDON], FACP, FACC

Cardiologist

The Ottawa Hospital
Ottawa, Canada

Associate Professor of Medicine
University of Ottawa
Ottawa, Canada



ELSEVIER

AMSTERDAM • BOSTON • HEIDELBERG • LONDON
NEW YORK • OXFORD • PARIS • SAN DIEGO
SAN FRANCISCO • SINGAPORE • SYDNEY • TOKYO

Academic Press is an imprint of Elsevier



Elsevier Academic Press
30 Corporate Drive, Suite 400, Burlington, MA 01803, USA
525 B Street, Suite 1900, San Diego, California 92101-4495, USA
84 Theobald's Road, London WC1X 8RR, UK

This book is printed on acid-free paper. ♾

Copyright © 2006, Elsevier Inc. All rights reserved.

No part of this publication may be reproduced or transmitted in any form or by any means, electronic or mechanical, including photocopy, recording, or any information storage and retrieval system, without permission in writing from the publisher.

Permissions may be sought directly from Elsevier's Science & Technology Rights Department in Oxford, UK: phone: (+44) 1865 843830, fax: (+44) 1865 853333, E-mail: permissions@elsevier.com. You may also complete your request on-line via the Elsevier homepage (<http://elsevier.com>), by selecting "Customer Support" and then "Obtaining Permissions."

Library of Congress Cataloging-in-Publication Data

Application submitted

British Library Cataloguing in Publication Data

A catalogue record for this book is available from the British Library

ISBN 13: 978-0-12-406061-6

ISBN 10: 0-12-406061-7

For all information on all Elsevier Academic Press publications
visit our Web site at www.books.elsevier.com

Printed in the United States of America

05 06 07 08 09 10 9 8 7 6 5 4 3 2 1

Working together to grow
libraries in developing countries

www.elsevier.com | www.bookaid.org | www.sabre.org

ELSEVIER

BOOK AID
International

Sabre Foundation

CONTENTS

<i>About the Author</i>	<i>xv</i>	Anemia and the Heart	25
<i>Preface</i>	<i>xvii</i>	I. Anemia and Heart Function	25
<i>Acknowledgments</i>	<i>xix</i>	II. Clinical Studies	25
		Bibliography	26
Aging and the Heart	I	Aneurysm	27
I. The Size of the Problem	I	I. Abdominal Aortic Aneurysm	27
II. Effects of Aging on the Heart and		II. Thoracic Aortic Aneurysm	30
Vascular System	I	III. Aortic Dissection	31
III. Cardiovascular Therapy in the Elderly	2	IV. Berry Aneurysm	32
IV. Research Implications	3	Bibliography	32
Bibliography	3		
Alcohol and the Heart	5	Angina	35
I. Alcohol and Coronary Heart Disease	5	I. Size of the Problem	35
II. Alcohol and Hypertension	6	II. Pathophysiology	36
III. Alcohol and Heart Failure	6	III. Diagnosis	39
IV. Alcohol and Cardiomyopathy	6	IV. Disease Processes Causing	
V. Alcohol and Abnormal Heart Rhythms		Angina	40
and Abnormal Electrocardiograms	7	V. Stable and Unstable Angina	41
VI. Alcohol and Coagulation Factors and Stroke	7	VI. Nondrug Treatment	42
VII. Type of Alcohol Consumption	7	VII. Drug Treatment	45
VIII. Perspective	8	VIII. Hypertension	53
Bibliography	8	IX. Angina Patients with Heart Failure	53
Altitude and Pulmonary Edema	9	X. Silent Ischemia	53
I. Signs and Symptoms	9	XI. Variant Angina	
II. Mechanisms	9	(Prinzmetal's Angina)	53
III. Management	10	XII. Unstable Angina/Acute	
IV. Clinical Study	10	Coronary Syndrome	54
V. Perspective and Research Implications	10	Bibliography	55
Bibliography	11		
Anatomy of the Heart and Circulation	13	Angioplasty/Coronary Balloon	57
I. Anatomic Features	13	I. Procedure	57
II. Circulation of Blood	21	II. Indications	58
Bibliography	21	III. Contraindications and Limitations	58
Anderson-Fabry Disease	23	IV. Outcome of Angioplasty	59
Bibliography	23	Bibliography	60

Angiotensin-Converting Enzyme Inhibitors/Angiotensin Receptor Blockers	61	Artificial Heart	105
I. ACE Inhibitors	61	I. Electric Total Artificial Heart	105
II. Angiotensin II Receptor Blockers	65	II. Left Ventricular Assist Device	107
Bibliography	67	III. Is There a Logical Role for Ventricular Assist Devices?	108
Antihistamines	69	IV. New Frontiers	109
I. Histamine Antagonists	69	Bibliography	109
Bibliography	69	Aspirin for Heart Disease	111
Antioxidants	71	I. Historical Review	111
I. Statins	71	II. Mechanism of Action	112
II. Vitamin E	72	III. Recognized Indications for Aspirin and Dose	113
III. Vitamin C	73	IV. Perspective	114
IV. Beta-Carotene	73	Bibliography	114
V. Mediterranean Diet	74	Atherosclerosis/Atheroma	117
VI. Dietary Plant-Derived Flavonoids	74	I. Introduction and Historical Background	117
VII. French Red Wine	74	II. Pathology	119
VIII. ProbucoI	75	III. Pathogenesis	121
Bibliography	75	IV. Vulnerable Atheromatous Plaques	127
Antiphospholipid Antibody Syndrome	77	V. Clinical Studies	127
I. Diagnosis	77	VI. Perspective and Research Implications	128
II. Management	77	Bibliography	130
Bibliography	77	Athletes and Sudden Cardiac Death	131
Antiplatelet Agents	79	I. Cardiac Causes of Sudden Death in Young Athletes	132
I. Mechanism of Action	79	II. Sudden Death Not Associated with Cardiac Disease	135
II. Indications	80	III. Athlete's Heart Versus Hypertrophic Cardiomyopathy	136
III. Available Antiplatelet Agents	80	Bibliography	137
Bibliography	83	Atrial Fibrillation	139
Arginine and the Heart	85	I. Epidemiology	140
I. Clinical Study	85	II. Diagnosis	140
Bibliography	85	III. Causes and Research Implications	141
Arrhythmias/Palpitations	87	IV. Pathophysiology	143
I. Origin of the Heartbeat	87	V. Classification and Management	143
II. Palpitations, Premature Beats, and Irregular Beats	88	VI. Anticoagulants	148
III. Tachycardia	89	VII. Electronic Pacing	149
IV. Antiarrhythmic Agents	95	Bibliography	149
V. Automatic Implantable Cardioverter Defibrillator	100	Atrial Septal Defect	151
VI. Conclusion	100	I. Clinical Study	151
Bibliography	100	Bibliography	152
Arteriosclerosis	101	B-Type Natriuretic Peptide	153
I. Diseases Causing Arteriosclerosis	101	I. Clinical Studies	153
II. Atherosclerosis	102	II. Perspective	154
Bibliography	103	Bibliography	155

Beriberi Heart Disease	157	IV. Next Generation Agents	196
I. Clinical Manifestations	157	Bibliography	197
Bibliography	157	Carcinoid Heart Disease	199
Beta-Blockers	159	I. Heart Damage	199
I. Beta-Receptors	160	II. Diagnosis	199
II. Mechanism of Action	160	III. Treatment	200
III. Salutary Effects	160	IV. Clinical Study	200
IV. Indications	161	Bibliography	200
V. Clinical Trials	163	Cardiogenic Shock	201
VI. Adverse Effects and Cautions	164	I. Causes	201
VII. Classification	164	II. Pathophysiology	201
VIII. Subtle Differences and Research Implications	165	III. Management	202
IX. Individual Beta-Blockers	166	IV. Perspective and Research Implications	202
Bibliography	167	Bibliography	202
Blood Clots	169	Cardiomyopathy	203
I. Causes of Blood Clots	169	I. Hypertrophic Cardiomyopathy	204
II. Nondrug Treatment	170	II. Sudden Death	207
III. Drug Treatment	170	III. Dilated Cardiomyopathy	209
Bibliography	174	IV. Restrictive Cardiomyopathy	211
Blood Pressure	175	V. Specific Heart Muscle Disease	211
I. Historical Review	175	Bibliography	212
II. Systolic and Diastolic Blood Pressure	178	Cardiopulmonary Resuscitation (CPR)	215
III. Classification	178	I. Causes of Loss of Consciousness	215
IV. Normal Fluctuations in Blood Pressure	178	II. Cardiac Arrest Rhythms	216
V. Finger Cuff Method of Penaz	180	III. Cardiopulmonary Resuscitation	216
VI. Technique and Pitfalls of Measurement	180	IV. Defibrillation	219
VII. Effects of High Blood Pressure	180	V. Drugs for Cardiac Arrest	220
Bibliography	180	VI. Perspectives and Research Implications	221
Brugada Syndrome	183	VII. Outcomes of Out-of-Hospital Cardiac Arrest	221
I. Clinical Features	183	VIII. The Heimlich Maneuver	222
II. Perspective	184	Bibliography	222
Bibliography	184	Chagas Disease	223
Bundle Branch Block	185	I. Epidemiology	223
I. Right Bundle Branch Block	185	II. Symptoms and Signs	223
II. Left Bundle Branch Block	187	III. Diagnostic Investigations	225
Bibliography	187	IV. Management	225
Caffeine and the Heart	189	Bibliography	225
I. Biochemistry	189	Chelation and Heart Disease	227
II. Effects	190	I. Clinical Study	227
Bibliography	191	II. Perspective	227
Calcium Antagonists	193	Bibliography	228
I. Mechanism of Action	193	Abstract	228
II. Available Calcium Antagonists	194	Chemotherapy-Induced Heart Disease	229
III. Therapeutic Benefits	196	I. Chemotherapeutic Agents	229
		II. Cardiac Damage from Anthracyclines	229

III. Cyclophosphamide	231	III. Perspective and Research Implications	279
IV. 5-Fluorouracil	231	Bibliography	280
Bibliography	232		
Cholesterol	233	Cytochrome P-450	281
I. The Magnitude of the Problem	233	I. Definition and Nomenclature	281
II. Historical and Clinical Trials	233	II. Functions	281
III. Causes of Hypercholesterolemia	235	III. P-450s Regulation	283
IV. Types of Cholesterol	236	IV. P-450s and Cardiovascular Drug Interactions	283
V. Blood Tests	240	Bibliography	285
VI. Coronary Artery Disease Risk	241		
VII. Diets and Cholesterol	242	Deep Vein Thrombosis	287
VIII. Cholesterol-Lowering Drugs	244	I. Incidence and Location	287
Bibliography	246	II. Pathogenesis of Deep Vein Thrombosis	287
		III. Diagnostic Features	288
		IV. Management	289
		Bibliography	290
Coenzyme Q10	247	Depression and the Heart	291
I. Actions	247	I. Pathophysiologic Mechanisms	291
II. Clinical Study	247	II. Drug Management	291
III. Prospective and Research Implications	249	Bibliography	292
Bibliography	249		
Congenital Heart Disease	251	Diabetes and Cardiovascular Disease	293
I. Incidence and Classification	251	I. Size of the Problem	293
II. Ventricular Septal Defect	252	II. Clinical Features and Complication of	
III. Patent Ductus Arteriosus	253	Type 2 Diabetes	294
IV. Aortic Stenosis	254	III. Pathogenesis of Type 2 Diabetes and	
V. Bicuspid Aortic Valve	254	Research Implications	295
VI. Coarctation of the Aorta	254	IV. Maturity Onset Diabetes of the Young	299
VII. Other Congenital Anomalies	255	V. Management of Type 2 Diabetes	299
VIII. Congenital Cyanotic Heart Disease	256	VI. Hyperglycemic Hyperosmolar Coma	301
Bibliography	261	VII. Dyslipidemia in Type 2 Diabetes	301
		VIII. Clinical Studies, Type 2 Diabetes	302
		IX. Coffee Consumption and Risk of Type 2	
		Diabetes	302
		X. Insulin Resistance	303
		XI. Type 1 Diabetes	303
		Bibliography	306
Contraception and Cardiovascular Disease	263	Diets and Heart Disease	307
I. Oral Contraceptives	263	I. Diets	307
Bibliography	265	II. Trans Fatty Acids and Coronary	
		Artery Disease	308
		III. Diet–Drug Valvulopathy	310
		IV. Fish Oils	311
		Bibliography	311
Coronary Artery Bypass Surgery	267	Diuretics	313
I. The Coronary Arteries	267	I. Indications	313
II. Indications	268	II. Renal Physiology	314
III. Types of Grafts	268	III. Individual Diuretics	315
IV. Outcomes	270	Bibliography	318
V. Complications	271		
VI. Surgery in the Elderly	272		
VII. Contraindications	273		
VIII. Medications	273		
IX. Coronary Bypass Surgery Versus PCI	274		
Bibliography	275		
C-Reactive Protein and the Heart	277		
I. A Marker of Risk	277		
II. Clinical Studies	278		

Down Syndrome	319	Erectile Dysfunction and the Heart	367
I. Genetics	319	I. Mechanism of Erectile Dysfunction	367
II. Incidence of Congenital Heart Malformations	319	II. Causes of Erectile Dysfunction	369
Bibliography	319	III. Management	369
Dyslipidemia	321	Bibliography	373
I. Lipoproteins	321	Exercise and the Heart	375
Bibliography	326	I. Benefits of Exercise	375
Echocardiography	327	II. Aerobic Exercise	376
I. Historical	327	III. Isometric, Static Exercise	380
II. Instrumentation	328	IV. Weight Reduction and Exercise	381
III. Echocardiographic Examination	328	V. Effects on Blood Pressure and Atheroma	381
IV. Clinical Applications	329	VI. Effects on Blood	382
V. Research Implications	332	VII. Clinical Studies of Exercise and Heart Disease	383
VI. New Frontiers	333	VIII. Injuries During Jogging	385
Bibliography	333	IX. How to Start an Exercise Program	385
Effects of Smoking and Heart Disease	335	X. Exercise Stress Test	387
I. Effects of Components of Cigarette Smoke	335	XI. Conclusion	388
II. Cigarette Smoke and Atherosclerosis	337	Bibliography	388
III. Recent Epidemiologic Study	337	Gene Therapy	391
IV. Anginal Chest Pain and Impotence	337	I. Strategies	391
V. Habituation and Cessation	338	II. Clinical Application	392
Bibliography	338	III. Clinical Trials	394
Electrocardiography	341	IV. Adverse Outcomes	394
I. Historical	341	Bibliography	395
II. General Applications	342	Heart Attacks	397
III. The Normal Electrocardiogram	343	I. Perspective	398
IV. Diagnosis of Specific Conditions	343	II. Causes and Pathophysiology	398
V. Recent Discoveries	349	III. Door-to-Needle Time	400
Bibliography	349	IV. Symptoms	400
Embryology	353	V. Physical Signs	405
I. Development of the Heart	353	VI. Mimics of a Heart Attack	405
Bibliography	357	VII. Ambulance Transport	407
Endocarditis	359	VIII. What to Expect in the Hospital	409
I. Definition and Sites of Infection	359	IX. Diagnostic Tests	411
II. Diagnosis	359	X. Specific Management	413
III. Therapy	360	XI. Clinical Trials	417
IV. Prevention	360	XII. Non-ST Elevation Myocardial Infarction	417
Bibliography	361	XIII. Complications of Myocardial Infarction	418
Endocrine Disorders and the Heart	363	XIV. Heart Attack and Emotional Impact	420
I. Acromegaly	363	XV. Depression and Anxiety	420
II. Thyroid Diseases	364	XVI. Diet After a Heart Attack	421
III. Adrenal Disorders	364	XVII. Rehabilitation, Retirement, and Travel	421
Bibliography	365	XVIII. Retirement and Travel	423
		XIX. Sexual Activities	423
		XX. Beta-Blockers	424
		XXI. Eplerenone (INSPRA)	426
		XXII. Case History of a Heart Patient	426

XXIII. Risk Factors and Prevention	427	II. How High is High?	471
XXIV. Heart Attack Prevention Diet	428	III. Causes of Hypertension	471
Bibliography	429	IV. Pathogenesis of Primary Essential Hypertension	474
Heart Failure	433	V. Complications	476
I. Incidence and Pathogenesis	433	VI. Symptoms	477
II. Basic Causes of Heart Failure	434	VII. Investigations	477
III. Precipitating Factors	435	VIII. Nondrug Treatment	478
IV. Pathophysiology	436	IX. Drug Treatment	480
V. Symptoms and Signs	437	Bibliography	490
VI. Diagnosis	438	Hypertrophy of the Heart	493
VII. Drug Treatment	438	I. Pathophysiology	493
VIII. Nondrug Therapy	444	II. Causes and Complications of Heart Hypertrophy	495
IX. What to Expect in the Hospital and on Discharge	445	III. Diagnosis	495
Bibliography	446	IV. Prevention and Management	497
Hemochromatosis	449	Bibliography	499
I. Incidence	449	Kawasaki Heart Disease	501
II. Genetics and Iron Overload	449	I. Clinical Features	501
III. Clinical Complications	450	II. Diagnosis	501
IV. Management	451	III. Causation	502
Bibliography	451	IV. Management	502
Herbal, Dietary Supplements, and Cardiovascular Disease	453	Bibliography	502
I. Historical	453	Miscellaneous Disorders	505
II. Consumption and Regulation	453	I. Marfan Syndrome	505
III. Benefits, Adverse Effects, and Drug Interactions	454	II. Cor Pulmonale	505
IV. Substances Used by Athletes	460	III. Ehlers-Danlos Syndrome	506
Bibliography	461	IV. Noonan Syndrome	506
HIV and the Heart	463	V. Ebstein's Anomaly	507
I. Incidence	463	VI. Turner Syndrome	507
II. Cardiac Complications of AIDs	463	VII. Fetal Alcohol Syndrome	507
Bibliography	464	VIII. Holt-Oram Syndrome	507
Homocysteine and Cardiovascular Disease	465	IX. Paget's Disease	507
I. Homocysteine Metabolism	465	X. Ankylosing Spondylitis	507
II. Homocysteine and Vascular Disease	465	XI. Rubella Syndrome	507
III. Clinical Studies	465	XII. Pseudoxanthoma Elasticum	507
IV. Conditions Causing Hyperhomocystinemia	466	XIII. Myotonic Muscular Dystrophy	508
V. Screening	466	XIV. Takayasu	508
VI. Management of Hyperhomocystinemia	467	XV. Lupus Erythematosus	508
VII. Benefits of Decreasing Homocysteine Levels	467	XVI. Sarcoidosis	509
VIII. Clinical Studies	467	XVII. Syphilis	509
Bibliography	468	XVIII. Atrial Myxoma	509
Hypertension	469	Bibliography	509
I. Measurement of Blood Pressure	469	Murmurs and Heart Disease	511
		I. Clinical Cases	511
		II. Clinical Diagnosis of Heart Murmurs	512
		III. Investigative Tests	514
		Bibliography	514

Nonsteroidal Anti-Inflammatory Drugs	515	Sleep and the Heart	559
I. Adverse Cardiovascular Effects	515	I. Effects of Normal Sleep on the	
Bibliography	517	Cardiovascular System	559
Obesity and Heart Disease	519	II. Sleep Apneas	559
I. Incidence and Definitions	519	III. Sleep Apnea and Heart Failure	560
II. Effects on the Cardiovascular System	521	IV. Sleep Apnea and Hypertension	563
III. Management	521	V. Sleep Apnea and Arrhythmias	563
IV. Clinical Studies of Diets	523	Bibliography	563
Bibliography	524	Stents	565
Pacemakers	525	I. A Major Advance	565
I. Historical	525	II. Restenosis	565
II. Complete Heart Block	526	III. Drug-Eluting Stents	566
III. Second Degree AV Block	528	IV. Problems to be Resolved	567
IV. Sinus Node Dysfunction	528	Bibliography	568
V. Permanent Pacemakers	529	Stress and Heart Disease	569
VI. What a Pacemaker Will Not Do	532	I. Effects on the Cardiovascular System	569
VII. Activities	532	II. Type A Behavior	572
Bibliography	532	Bibliography	573
Patent Foramen Ovale	533	Stroke/Cerebrovascular Accident	575
I. Developmental Features	533	I. Incidence	575
II. Clinical Features and Investigations	535	II. Types of Cerebrovascular Accidents	575
III. Proof of PFO Involvement in Stroke	535	III. Cerebral Infarction/Ischemic Stroke	576
IV. Perspective and Research Implications	537	IV. Transient Ischemic Attack	577
Bibliography	537	V. Intracranial Hemorrhage	578
Pericarditis and Myocarditis	539	VI. Subarachnoid Hemorrhage	578
I. Pericarditis	539	Bibliography	578
II. Myocarditis	541	Syncope	581
Bibliography	541	I. Definition and Incidence	581
Pulmonary Arterial Hypertension	543	II. Causes	581
I. Pulmonary Hypertension	543	III. Diagnostic Evaluation	584
II. Primary Pulmonary Hypertension	545	IV. Management	586
Bibliography	547	Bibliography	588
Pulmonary Embolism	549	Tests for Heart Diseases	589
I. Incidence	549	I. Electrocardiogram	589
II. Pathogenesis	549	II. Exercise Treadmill Stress Test	589
III. Pathophysiology	549	III. Chest X-Ray	590
IV. Diagnosis	550	IV. Echocardiogram	590
V. Investigations	550	V. Holter Monitor	590
VI. Management	551	VI. Nuclear Scans	590
Bibliography	551	VII. Coronary Arteriography/Cardiac	
Race and Cardiovascular Disease	553	Catheterization	591
I. Hypertension	553	VIII. Coronary Calcium Evaluation	593
II. Heart Failure	554	IX. Cardiovascular Magnetic Resonance	
III. Coronary Artery Disease and Stroke	556	Imaging/Magnetic Resonance Angiography	593
Bibliography	557	Bibliography	594

Thyroid Heart Disease	597	Ventricular Fibrillation	607
I. High Thyroid (Hyperthyroidism)	597	I. Clinical Features	607
II. Low Thyroid (Hypothyroidism)	597	II. Genesis and Causes	607
III. Amiodarone-Induced Thyroid Dysfunction	598	III. Management Bibliography	608 608
Bibliography	598	Women and Heart Disease	609
Valve Diseases	599	I. Relevant Statistics and Perspectives	609
I. Murmurs	599	II. Recognized Differences in Women and Men	610
II. Causes and Consequences of Valve Disease	599	III. Hormone Therapy	611
III. Rheumatic Fever	600	IV. Pregnancy and Heart Disease	612
IV. Specific Valve Lesions	601	Bibliography	614
V. Prosthetic Valve Choice	604	Appendix A	617
Bibliography	606	Appendix B	619
		Glossary	621
		Index	627

ABOUT THE AUTHOR

Doctor M. Gabriel Khan is a cardiologist at the Ottawa Hospital and an Associate Professor of Medicine at the University of Ottawa. Dr. Khan graduated MB, BCh, with First Class Honours at The Queen's University of Belfast. He is a Fellow of the American College of Cardiology, the American College of Physicians, and the Royal College of Physicians of London and Canada.

He is the author of

- *Cardiac Drug Therapy*, sixth edition, 2003, W.B. Saunders/Elsevier, Philadelphia.
- *On Call Cardiology*, second edition, 2001, W.B. Saunders/Elsevier, Philadelphia.
- *Rapid ECG Interpretation*, second edition, 2003, W.B. Saunders/Elsevier, Philadelphia.
- *Cardiac and Pulmonary Management*, 1993, Lea & Febiger, Philadelphia.
- *Medical Diagnosis and Therapy*, 1994, Lea & Febiger, Philadelphia.
- *Heart Attacks, Hypertension and Heart Drugs*, second edition, 1990, Bantam/Seal, Toronto.
- *Heart Trouble Encyclopedia*, 1996, Stoddart, Toronto.
- *Heart Disease Diagnosis and Therapy, a Practical Approach*, second edition, 2005, Humana Press, New Jersey.

His books are read worldwide, having acquired foreign translations: Chinese, French, Farsi, German, Greek, Italian, Japanese, Polish, Portuguese, Russian, Spanish, and Turkish.

Here is an excerpt from the foreword, written by a renowned cardiologist and author, Dr. Henry J. L. Marriott for the recent book, *Heart Disease Diagnosis and Therapy*:

"Whenever I read Khan, I am affected as the rustics were by Oliver Goldsmith's parson:

And still they gaz'd, and still the wonder grew
That one small head could carry all he knew.

Khan's knowledge is truly encyclopedic and, for his fortunate readers, he translates it inot easily read prose."

And for the book *Cardiac Drug Therapy*, fourth edition, a cardiologist reviewer states, "By far the best handbook on cardiovascular therapeutics I have ever had the pleasure of reading. The information given in each chapter is up-to-date, accurate, clearly written, eminently readable and well referenced."

And from *Clinical Cardiology* a review of the fifth edition of *Cardiac Drug Therapy*, "This is an excellent book. It succeeds in a very practical way while presenting the major evidence in relation to its recommendations. From the trainee to the experienced consultant, all will find it useful. The author stamps his authority very clearly throughout the text by very clear assertions of his own recommendations even when these recommendations are at odds with those of official bodies. In such situations the "official" recommendations are also stated but clearly are not preferred."

PREFACE

This encyclopedic work is directed at all who wish to pursue a research career in science and technology, including the medical sciences. Importantly, both career researchers and those who wish to devote only a few years in research will find the information provided invaluable. Postgraduates in science and technology, including MDs, and PhDs who wish to pursue research in the medical sciences must have a reference source that provides core knowledge in medicine, particularly diagnostic techniques and management strategies, with research implications. The text provides this information.

It is relevant to state that often major discoveries are made by those who pursue only a few years in research and innovations may be made by simple thought processes. A prime example is the one revealed by Reverend Hales, the father of hemodynamic medicine. During his studies in theology at Cambridge he was fortunate to do mathematics and science and had conversations with a medical student. In 1733, after many years in his ministry, at Teddington outside London he found the time for the study of circulation. Figure 1 in the chapter on Blood Pressure shows Hales observing the blood pressure in a horse, and he is credited to be the first to demonstrate measurement of blood pressure.

The vascular surgeon Korotkoff, in Russia in 1900, recognizing that a constricted artery makes no sound, used a stethoscope to observe the sounds made by the blood flowing through the artery in the arm constricted by an arm band; he heard sounds as the band was released. The first sounds were taken as the systolic blood pressure and the sounds are called Korotkoff sounds; the technique is used to this day without change. Korotkoff's innovative discovery required only his thought of sound; he was not a researcher. Surgeons do not normally use stethoscopes but vascular surgeons do so, because they listen over expanded arteries, aneurysms that emit a loud bruit, a sound made as the blood strikes the expanded wall of the artery.

Many of the technologic advances in medicine have been provided for us by the collaboration of engineers,

physicists, biologists, and medical doctors. Einthoven would not have produced the electrocardiogram in 1901 if Adler had not provided the wireless telegraph; also, the string galvanometer, a nonmedical device, was then available to Einthoven.

The advent of ultrasonography was an innovation prompted by the Titanic disaster and in 1939 the underwater search for submarines. At the end of the war physicists and medical doctors collaborated to provide the ultrasound for neurologic investigations. Echocardiography stemmed from an engineer who worked in collaboration with a medical student and a physician. In 1964 Dr. Harvey Feigenbaum saw the unsophisticated machine at the American college of cardiology scientific session. He went back to his lab and borrowed an ultrasound machine from the neurosurgical division and used this to show that pericardial effusions around the heart could be observed by ultrasonic technique and presented his hallmark paper. His research work was not overwhelming and did not require much scientific thought or expertise. He was not a major research scientist. Many of the advances in echocardiography during 1965 or to 1990 can be attributed to his work and to sophistication by engineers.

The text often describes historical events that led up to certain hallmark discoveries; this is done to indicate to those interested in research that simple thoughts and perseverance bring fruits from research. It is my hope that this historical information will provide motivation and awakening of new interests in the solving of the pathogenesis, pathophysiology, diagnosis, and management strategies of a variety of heart diseases.

Most important, at the end of topics discussed a section on research implications is provided. What is known and what is unknown is put in perspective. A prime example is the knowledge that is available on the development of atheroma and atherothrombosis, a disease process responsible for heart attacks, angina, sudden deaths, stroke intermittent claudication, and gangrene of the leg. The word atheroma is derived from the Greek word "athere" meaning porridge or gruel. Ancient Greek physicians

removed plaques of atheroma that obstructed arteries, and cutting the plaque of atheroma revealed a gelatinous porridge-like material. We still know little about the growth of atheromatous obstructions in arteries that cause heart attacks and strokes.

This disease process is currently responsible for more than 14 million deaths annually worldwide and it is believed that this will increase to about 25 million deaths in the year 2020 in a population of 7.4 billion people. This widespread disease causes more deaths than all forms of cancer, diabetes, infections, and asthma and lung diseases. Yet its prevention has defeated the medical profession

because there is a relative paucity of research work done in this area. We desperately need technologic instruments to provide noninvasive detection of atheromatous obstruction in coronary arteries that presently can only be observed with certainty by coronary angiography, and invasive procedure; electron beam CT scanning to determine calcium scores is expensive and not sufficiently helpful.

The text gives numerous illustrations to provide the reader with relevant insights and to render the material more user friendly. I trust that this volume will reach the hands and eyes of those who wish to quell the worldwide epidemic of cardiovascular disease.

M. Gabriel Khan
September 2005

ACKNOWLEDGMENTS

I am indebted to researchers worldwide whose works were used to produce this fund of knowledge for future researchers in the field of cardiovascular medicine. I feel certain that the names of many researchers have been omitted because of my oversight and because references provide only three names, *et al.*

Hilary Rowe, my Publisher at Elsevier, had the foresight to accept my proposal to provide researchers in the technologic and medical field with an *Encyclopedia of Heart Diseases*. I must express my thanks to her and her team that includes:

- Erin LaBonte-McKay who assisted me with acquiring permissions.
- Paul Gottehrer who faced the task of production of the book without disappointing me. The printing style is what I requested. A text that is non-compressed, user-friendly, and with well-positioned illustrations. Few publishers are able to follow the whims of authors.

There is little doubt, however, that without the love and commitment of my wife Brigid, this daunting task of the production of a single-authored, 91-chapter book would not have been possible.

Aging and the Heart

- I. The Size of the Problem
- II. Effects of Aging on the Heart and Vascular System
- III. Cardiovascular Therapy in the Elderly
- IV. Research Implications

GLOSSARY

- coronary heart disease** obstruction of the coronary arteries with symptoms such as chest pain, angina, or heart attacks.
- coronary thrombosis** obstruction of a coronary artery by blood clot.
- heart failure** a failure of the heart to pump sufficient blood from the chambers into the aorta; inadequate supply of blood reaches organs and tissues.
- hypertension** high blood pressure.
- hypertrophy** increase in thickness of muscle.
- myocardial infarction** death of an area of heart muscle due to blockage of a coronary artery by blood clot and atheroma; medical term for a heart attack or coronary thrombosis.
- myocardium** the heart muscle.

I. THE SIZE OF THE PROBLEM

In the year 2000 there were approximately 35 million people in the United States who were 70 years and older. In the year 2030, the number will be approximately 70 million. The world population of the elderly is approximately 610 million and will grow to approximately 2 billion by 2050. There is an epidemic of heart failure in this aging population. In the United States, heart failure is the most common diagnostic related group in the population over 65. Coronary heart disease and stroke are very common. More than 60% of these individuals have hypertension, which is an important underlying cause of heart failure. Atrial fibrillation, a serious abnormal heart rhythm, is common in the age group 70 to 85; this condition requires treatment with a blood thinner, warfarin, to prevent strokes. The main underlying cause for atrial fibrillation is hypertension.

The prevention of morbidity and mortality in this age group requires the aggressive management of hypertension.

Heart failure has several causes including hypertension, and the prevention and management of heart failure with old and new remedies require a concerted effort and relevant new research.

II. EFFECTS OF AGING ON THE HEART AND VASCULAR SYSTEM

A. Gross Anatomy

Aging causes decreased elasticity and compliance of the aorta and great arteries arterial stiffness. This results in higher systolic arterial pressures and increased impedance of the propagation of blood from the left ventricle through the arterial system and the delivery of blood to organs and tissues. Mild left ventricular hypertrophy also occurs.

B. Histological Changes

These changes in the heart muscle include decreased mitochondria and altered mitochondrial membranes. Increased collagen degeneration and interstitial fibrosis with increased lipid and amyloid deposition causes the left ventricular muscle mass to become stiffer. Because of this stiffness, after the systolic contraction of the ventricle it takes longer for the ventricular mass to relax in diastole. This defect in relaxation and an abnormal dispensability causes the ventricle to fail. Thus insufficient blood to meet the demands of the tissues is propelled into the arterial system and heart failure ensues. This condition is referred to as diastolic heart failure. The exact underlying causes for diastolic heart failure require further study. More knowledge will improve today's unsatisfactory therapy for this condition.

Heart failure is commonly caused by systolic dysfunction of the ventricle. The ventricular muscle mass is weakened by scarring from heart attacks and other cardiac diseases. Failure of the muscle pump causes insufficient blood to be expelled from the ventricle into the arteries. Treatment for systolic heart failure has improved considerably since 2000.

C. Biochemical Changes

These changes include decreased protein elasticity, changes in enzyme content that affect metabolic pathways, decreased catecholamine synthesis, and diminished responsiveness to beta-adrenergic stimulation.

D. Electrical Conduction System

Substantial loss of pacemaker cells in the sinus node cause a fall in heart rate and finally failure. This condition is called sick sinus syndrome and is the most common reason for implanting an electronic pacemaker. Increased fibrosis and calcification of the conduction system and loss of specialized cells in the His bundle and bundle branches can result in failure of the electrical impulse to reach the ventricles. This condition is called heart block and requires a pacemaker. (See the chapter Pacemakers.)

E. Valvular Changes

These changes include fibrosis, thickening and calcification of heart valves which leads to degenerative valvular disease. Calcified aortic stenosis may require valve surgery but the statins, cholesterol-lowering agents, have been shown to decrease the rate of stenosis and may delay surgical intervention. Mitral annular calcification occurs commonly and occasionally causes mitral regurgitation, atrial arrhythmia, heart block, and infective endocarditis.

Fibroproliferative lesions producing mitral regurgitation has occurred in elderly patients treated with anti-parkinsonian dopamine receptor agonist pergolide.

III. CARDIOVASCULAR THERAPY IN THE ELDERLY

A. Thrombolytic Therapy

Patients 70 years or older with an acute myocardial infarct are at high risk for serious events. Thrombolytic therapy may prevent death and further morbidity. Unfortunately, in patients older than 75 there is an increased risk of intracranial bleeding. This excessive risk must be balanced against any possible benefit derived from thrombolytic therapy. The incidence of intracranial hemorrhage in this age group is greater than 1.5% for alteplase (tissue plasminogen activator, t-PA) and tenecteplase, but greater than 0.5% for streptokinase.

Although intracranial hemorrhage incidence is lower with streptokinase, it is not the drug of choice in North

America. Fortunately, in the UK, Europe, and worldwide the less expensive agent streptokinase is still the most widely used pharmacologic reperfusion therapy. Thrombolytic agents that are effective but cause less intracranial bleeding than alteplase and tenecteplase in the elderly would be important additions to the therapeutic armamentarium.

B. Percutaneous Intervention

Because thrombolytic therapy carries a major risk of intracranial hemorrhage and stroke in patients over age 75, randomized clinical trials have confirmed the beneficial effects of primary coronary angioplasty with intracoronary stents. PCI is superior to thrombolytic therapy and is preferred if skilled cardiologists and facilities are readily available.

In a randomized study of 87 patients older than 75 with acute myocardial infarction, the composite of death, reinfarction, or stroke at 30 days occurred in 4 (9%) patients in the percutaneous intervention (PCI) group as compared with 12 (29%) in the patients receiving streptokinase intravenously ($p=0.01$). Patients older than 75 years of age with acute myocardial infarction or unstable angina obtain beneficial results with placement of a stent in the culprit coronary artery, blocked by atheroma and thrombosis.

C. Beta-Blocker Therapy

Beta-adrenergic blocking drugs, beta-blockers, have proven beneficial and save lives in patients with acute myocardial infarction regardless of age. Some caution is required because the elderly over the age of 75 may have disease of the sinus node and slow heart rates may occur if the dose of the beta-blocking drug is excessive. Small doses of these agents are also beneficial in the elderly patient with heart failure angina, atrial fibrillation, and hypertension. In the elderly hypertensive patient, a standing blood pressure should always be taken to document postural hypotension caused by vasodilatory anti-hypertensive agents. Beta-adrenergic blockers do not cause postural hypotension.

D. Calcium Antagonists

The calcium antagonists, or calcium entry blockers, are widely used to treat hypertension. From 1990 to 2002, the World Health Organization (WHO) and the joint national committee for advice on hypertensive treatment in the United States recommended the use of calcium antagonists as first line agents for management of hypertension in the

elderly. Their recommendation is illogical and somewhat misguided. These agents are well known to precipitate heart failure and should be used only in elderly patients who have no evidence of left ventricular dysfunction.

An epidemic of heart failure is occurring particularly in the elderly. Calcium antagonists increase the incidence of heart failure in the elderly because the aging heart loses its contractile function and abnormal histologic, anatomic, and biochemical changes occur that increase the risk of heart failure. Fortunately, the Antihypertensive and Lipid-Lowering Treatment to Prevent Heart Attack Trial (ALLHAT) showed conclusively that the use of a diuretic was more beneficial than calcium antagonists in the prevention of stroke mortality and heart failure. Importantly, this study showed that the alpha blocker doxazosin caused an increased risk for the development of heart failure and the use of alpha blockers should be curtailed. The result of this study will change recommendations and prescribing habits worldwide.

IV. RESEARCH IMPLICATIONS

The following is a list of research implications.

1. The processes that occur in the aging heart require intensive studies. As outlined earlier, the population of individuals 75 years and older is increasing and the incidence of heart failure and atrial fibrillation are increasing by leaps and bounds. The pathophysiology of the aging heart needs to be clarified. These answers will surely result in improvement and changes in therapeutic strategies.
2. It may be possible to prevent collagen degeneration and the fibrosis that stiffens the left ventricular muscle wall. Agents such as spironolactone cause a more complete block of aldosterone production than is achieved with angiotensin-converting enzyme (ACE) inhibition and reduce mortality and morbidity in patients with heart failure. The salutary effects are not only related to sodium and water loss by this mild diuretic, but also to a decrease in cardiac fibrosis, retardation of endothelial dysfunction, and increased nitric oxide vasodilator production. Tissue collagen turnover and fibrosis appear to be important facets of heart failure. Spironolactone may attenuate deleterious structural remodeling in the aging heart. A derivative compound, eplerenone (Inspra), has fewer adverse effects when compared with spironolactone and has been shown in a well-run randomized clinical trial to be an effective antihypertensive agent.
3. Damage to mitochondria must be addressed.
4. The use of beta-blocking drugs to treat hypertension in patients prior to age 65 and from age 65 to 80 may favorably alter myocardial processes and decrease the incidence of heart failure. This hypothesis needs to be tested. There are more than 12 beta-blocking drugs currently available, but subtle differences exist and carvedilol, bisoprolol, or metoprolol should be used in clinical trials for hypertension and heart failure and the use of atenolol, propranolol, sotalol, acebutolol, and other beta-blockers that are not shown to be cardioprotective in randomized clinical trials should be avoided.
5. Polypharmacy is common in the elderly. The majority of elderly patients take more than eight to 12 pills daily. Drug interactions occur commonly and results in a significant number of deaths that should be avoided by appropriate research and education to patients, physicians and nurses who render care for the elderly. Renal dysfunction is a common occurrence in the elderly, and importantly, a normal blood creatinine may be present in patients with significantly compromised renal function that can lead to drug toxicity.

BIBLIOGRAPHY

- Boer, M., Ottervanger, J., and Arnoud, W. Reperfusion therapy in elderly patients with acute myocardial infarction. *J. Am. Coll. Cardiol.*, 59:1723–8, 2002.
- Khan, M. G. Beta blockers the cornerstone of cardiac drug therapy. In *Cardiac Drug Therapy*, sixth edition, W.B. Saunders, Philadelphia, 2003.
- Lakatta, E. G., Levy, D. et al. Arterial and cardiac aging: Major shareholders in cardiovascular disease enterprises: Part I: Aging arteries: A "set up" for vascular disease. *Circulation*, 107:139–146, 2003.
- Lakatta, E. G. et al. Arterial and cardiac aging: Major shareholders in cardiovascular disease enterprises: Part III: Cellular and molecular clues to heart and arterial aging. *Circulation*, 107:490, 2003.
- Major Cardiovascular Events in Hypertensive Patients Randomized to Doxazosin vs Chlorthalidone
- Mehta, R. H., Granger, C. B., Alexander, K. P. et al. Reperfusion strategies for acute myocardial infarction in the elderly: Benefits and risks. *J. Am. Coll. Cardiol.*, 45:471–478, 2005.
- Pitt, B., Reichek, N., Willenbrock, R. et al. Effects of eplerenone, enalapril, and eplerenone/enalapril in patients with essential hypertension and left ventricular hypertrophy. The 4E-left ventricular hypertrophy study. *Circulation*, 108:1831, 2003.
- The ALLHAT Officers and Coordinators for the ALLHAT Collaborative Research Group:
The Antihypertensive and Lipid-Lowering Treatment to Prevent Heart Attack Trial (ALLHAT) *JAMA*, 283:1967–1975. 2000.
- The ALLHAT Officers and Coordinators for the ALLHAT Collaborative Research Group:
The Antihypertensive and Lipid-Lowering Treatment to Prevent Heart Attack Trial (ALLHAT Major Outcomes in High-Risk Hypertensive Patients Randomized to Angiotensin-Converting Enzyme Inhibitor or Calcium Channel Blocker vs Diuretic). *JAMA*, 288:2981–2997, 2002.

Alcohol and the Heart

- I. Alcohol and Coronary Heart Disease
- II. Alcohol and Hypertension
- III. Alcohol and Heart Failure
- IV. Alcohol and Cardiomyopathy
- V. Alcohol and Abnormal Heart Rhythms and Abnormal Electrocardiograms
- VI. Alcohol and Coagulation Factors and Stroke
- VII. Type of Alcohol Consumption
- VIII. Perspective

GLOSSARY

arrhythmia general term for an irregularity or rapidity of the heartbeat, an abnormal heart rhythm.

cardiomyopathy heart muscle disease.

cardioprotection protection of the heart from serious events that include coronary artery disease and its complications, angina, myocardial infarction and heart failure.

HDL cholesterol high density lipid; the good cholesterol.

heart failure a failure of the heart to pump sufficient blood from the chambers into the aorta; inadequate supply of blood reaches organs and tissues.

hypercholesterolemia high levels of cholesterol in the blood.

I. ALCOHOL AND CORONARY HEART DISEASE

The regular consumption of small quantities of alcohol — two drinks per day for men and one drink per day for women — appears to be associated with lower rates of cardiovascular events in most studies. These studies, however, do not have sound methodology. In most of these epidemiologic studies actual mortality rates are not stated and mainly relative risks are described.

Study question: Let's examine the relationship between alcohol intake and risk of coronary heart disease (CHD) among men with type 2 diabetes. Because type 2 diabetes is associated with an increased risk of CHD, Tanasescu et al. studied the effect of alcohol on the risk of CHD.

Methods: This included the study of 2419 men who reported a diagnosis of diabetes at age 30 or older in the health professional's follow-up study. Fifty new cases of CHD (81 nonfatal myocardial infarction and 69 fatal) were documented during 11,411 person-years of follow up.

Results: A questionnaire showed that alcohol use was inversely associated with risk of CHD. After controlling for body mass index (BMI), smoking, hypercholesterolemia, physical activity level, and other variables, relative risk (RR) was 0.78, 0.6, and 0.48 (p for trend = 0.03) corresponding to intake of less than 0.5 drinks per day, 0.5–2 drinks per day, and greater than 2 drinks per day.

Conclusions: The authors concluded that moderate alcohol consumption is associated with lower risk of CHD in men with type 2 diabetes. Results are consistent with those of the four recent studies that focused on the effect of alcohol on the occurrence of fatal or nonfatal myocardial infarction (MI).

Perspective: This is a limited study, and it is not surprising that there is so much confusion about alcohol and cardioprotection.

A. Alcohol and HDL Cholesterol

Several studies have confirmed that alcohol causes a modest increase in high density lipoprotein (HDL) cholesterol levels. There is a clear association between high levels of HDL cholesterol and longevity. Individuals aged 80 and older are often observed to have HDL cholesterol levels >1.8 mmol/L (>70 mg/dl). The majority of individuals aged 30–50 have HDL cholesterol levels between 0.9 to 1.5 mmol/L. The level <0.8 mmol/L [<30 mg/dl] is associated with a high risk for coronary heart disease. No large randomized study, however, has been done to show that if levels of HDL are increased by a drug that this decreases cardiovascular mortality and morbidity.

Moderate consumption of alcohol may cause about a 10–15% increase in HDL cholesterol, and this modest increase is probably cardioprotective but not proven to be so. Moderate consumption of alcohol probably can produce a maximum increase of 20%, but it carries the risk

of liver dysfunction, increased blood pressure, worsening heart failure, behavioral disturbances, and in rare instances, damage to the heart muscle. Women, because of their smaller BMI and differences in liver metabolism, should be advised not to exceed one drink a day if benefit is to be obtained without harm.

B. Alcohol Consumption and Hemostatic Factors

I. Analysis of the Framingham Offspring Cohort

Because cardioprotection is not fully explained by the modest increase in HDL cholesterol caused by alcohol, Mukamal et al. assessed the effects of alcohol on hemostatic factors.

Methods: There were 3223 adults from the Framingham offspring study done in 1971 used. These offspring were assessed 20 years later. Patients with coronary heart disease were excluded. Alcohol use was rated as none, <3, 3–7, 7–21, and more than 21 drinks per week.

Results: After allowing for variables of up to seven drinks per week, there were lower levels of fibrinogen, plasma viscosity, and von Willebrand factor. Seven to 21 drinks weekly were associated with impaired fibrinolytic potential and higher levels of type-1 plasminogen activator inhibitor (PAI-1) antigen and tissue plasminogen activator (t-PA) antigen.

Perspective: Light alcohol consumption is associated with lower levels of coagulation factors. Higher consumption may impair fibrinolytic activity. These results may help explain the apparent protective effect of mild alcohol consumption not found in heavy drinkers. It is not known whether individuals at high risk for CHD may benefit, because this group was excluded from study.

II. ALCOHOL AND HYPERTENSION

One drink daily does not significantly alter systolic blood pressure. Three or more drinks, however, may increase systolic blood pressure significantly in hypertensive individuals.

III. ALCOHOL AND HEART FAILURE

More than 4 oz of alcohol causes the heart muscle to pump less forcefully. Eight ounces of gin given to normal healthy students caused a 33% reduction in the amount of blood ejected from the left ventricle into the arteries.

Can you imagine a sick heart as a handicap? Acute depression of myocardial contraction is reversible and occurs for up to 12 h after consumption of alcohol. Reversible dysfunction of the left ventricle occurs, but why the reversible defect transfers to permanent damage to the heart muscle in only a few individuals is unknown.

Individuals who have had heart failure may have one drink a day without harm. More than 2 oz of alcohol or greater than 2 pints of beer or 3 oz of wine may depress cardiac function significantly. Patients in whom heart failure is due to alcoholic heart muscle disease (alcoholic cardiomyopathy) should never consume alcohol. If the condition is stable after 10 years, they may be able to consume 2 oz of alcohol daily without further harm to the heart muscle.

IV. ALCOHOL AND CARDIOMYOPATHY

A. Susceptibility and Pathogenesis

Fortunately, only in susceptible individuals does more than about four drinks six days per week for five to ten years result in damage to the heart muscle. This condition is called alcoholic cardiomyopathy. (See the chapter Heart Failure for information regarding reversible temporary cardiac muscle dysfunction versus permanent damage.) With cardiomyopathy, the heart becomes dilated and the muscle becomes flabby. Dilated cardiomyopathy is an important cause of heart failure. This is a disease of unknown cause where the heart muscle becomes swollen and enlarged and heart failure becomes severe. Genetic predisposition and viral infections may play a role, but approximately one-third of all cases of dilated cardiomyopathy is caused by excessive alcohol consumption (see the chapter, Cardiomyopathy).

Three basic factors appear to enhance alcohol myocardial damage:

1. A direct toxic effect of alcohol or its metabolites acting on the muscle cells
2. Nutritional deficiency, particularly thiamine deficiency that is a cause for beriberi heart disease; alcoholic cardiomyopathy, however, has been shown to occur in the absence of nutritional deficiencies
3. Toxic effects due to additives in the alcoholic beverage or derived from containers in which the alcohol is stored

B. Pathology

The pathology of alcoholic myocardial damage is interesting. The microscopic findings are similar to that of the

idiopathic dilated cardiomyopathy of unknown etiology. Myocytic hypertrophy, interstitial fibrosis, and disorganization of mitochondria with large glycogen-containing vacuoles may be observed. Further research is required to define the pathophysiology and therapeutic strategies to prevent this type of myocardial damage.

V. ALCOHOL AND ABNORMAL HEART RHYTHMS AND ABNORMAL ELECTROCARDIOGRAMS

Alcohol is a major cause of atrial fibrillation, which is the most common abnormal heart rhythm encountered in medical practice. This serious arrhythmia requires patients to be treated with oral anticoagulants to prevent stroke. Moderate alcohol consumption can cause atrial fibrillation. (See the chapter Atrial Fibrillation). In some patients atrial or ventricular premature beats and palpitations may occur. Alcohol consumption for several years can cause the electrocardiogram to show abnormal findings such as mild deformities of the ST segment and T waves.

VI. ALCOHOL AND COAGULATION FACTORS AND STROKE

Alcohol consumption is associated with an increased incidence of hemorrhagic stroke. Alcohol consumption alters coagulation factors as outlined above in the analysis of the Framingham study.

VII. TYPE OF ALCOHOL CONSUMPTION

A. Red Wine versus White Wine

Mild alcohol consumption causes a modest reduction in cardiovascular events. There has been considerable controversy, however, regarding what type of alcoholic beverages provides the greatest cardioprotection. Studies of the French population indicate that wine, particularly red wine, offers greater protection. Studies in the UK and other countries indicate that beer is as good or even slightly better. Studies in the United States indicate that spirits are as good as wine.

In human volunteers a high-fat diet has been shown to induce endothelial dysfunction while red wine counteracts it. Reportedly, the acute administration of red wine reduces the increase in nuclear factor κ B (NF- κ B) responsible for promoting the expression of several inflammatory genes

resulting from a high-fat meal. This effect was not observed for vodka.

The French, who eat rich food and drink more heavily than many other nationalities, have a much lower rate of heart disease events, the so-called French paradox (see the chapters Atherosclerosis/Atherothrombosis and Heart Attacks). Their high consumption of red wine appears to be the source of their cardioprotection. However, genetic factors may also be involved.

There appears to be significant differences between red and white wine. Red wine has a much higher content of the powerful antioxidants called polyphenols than white wine. These polyphenols appear to mop up oxygen free radicals that damage the arterial wall and may help to prevent damage caused by diabetes. French winemakers have recently increased levels of polyphenols in white wine by altering the wine-making process. They have done this by using white grapes that have a high polyphenol content and added more of the skins in which polyphenols are heavily concentrated. They softened the grapes for six days and the mixture was heated. This straw-yellow wine contains polyphenol levels four times higher than normal. Unfortunately, a controlled clinical trial to study the results of this new process is unlikely to take place.

B. French Red Wine versus German White Wine

Investigative study: Because endothelial type nitric oxide (NO) synthase exerts vasoprotective effects and red wine consumption has been associated with a reduction of cardiovascular disease but without molecular basis, Wallerath et al. studied the effect of red wine on endothelial-type nitric oxide synthase (eNOS) expression and eNOS activity in human endothelial cells.

Methods: In the method used in this study, human endothelial cells were treated with red wine and eNOS messenger ribonucleic acid (mRNA) was measured by RNase protection assay and other techniques.

Results: The results showed that incubation of endothelial cells with red wines from France upregulated eNOS mRNA and protein expression. In contrast, red wines from Germany showed little or no effect on eNOS expression. No significant difference in eNOS mRNA expression could be detected between “en barrique” (matured in oak barrels) and “non-barrique” (matured in steel attacks) produced French red wines. Endothelial cells treated with French red wines produced up to three times more bioactive NO than did control cells. French red wines increased the activity of the eNOS promoter, and the eNOS mRNA stability was also increased by red wine.

Conclusions: This study concluded that the increase in eNOS expression and activity brought about by red wines from France may contribute to the beneficial effects on the cardiovascular system. This observation provides a plausible and fascinating explanation for the differences in the European and American observations on the cardio-protective effects of different alcoholic beverages, but further research is required to resolve these important controversies.

VIII. PERSPECTIVE

The evidence that alcohol consumption is significantly cardioprotective is growing but inconclusive. If one or two drinks daily provides some beneficial effects, then these effects are modest. Most important, only those at higher risk for coronary heart disease may benefit. Thus individuals aged 20–40 should not use alcohol for cardioprotection, because these individuals are at low risk for heart disease. Individuals from age 40 to 80 with a strong family history of heart attack before age 60 and presence of hypertension or diabetes may obtain some protection, but studies have not provided a clear analysis. In any event the protection is expected to be approximately 10% risk reduction versus approximately 33% with use of statins to lower LDL cholesterol levels. It is noteworthy that trials on antioxidants such as beta-carotene have been shown to be noncardioprotective. The antioxidants in alcohol are unlikely to be sufficiently protective for individuals at high risk. Individuals at risks for coronary heart disease are advised to take medications that have been shown in randomized clinical trials (RCTs) to decrease mortality and cardiac events and not to rely on alcohol or herbal remedies that offer modest protection, if any at all.

Those who wish to take one drink or a maximum of two drinks daily should enjoy the pleasure if they feel more relaxed and enjoyment is derived. Individuals aged 45–80 may obtain approximately 10% reduction in cardiac event rates, but those who consume more than two drinks daily may suffer the disadvantage of an increased incidence of liver dysfunction, hemorrhagic stroke, and atrial fibrillation.

BIBLIOGRAPHY

- Appeldoorn, C. C. M., Bonnefoy, A., Lutters, B. C. H. et al. Gallic acid antagonizes P-Selectin – mediated platelet – leukocyte interactions: Implications for the French paradox. *Circulation*, 111:106–112, 2005.
- Blanco-Colio, L. N., Valderrama, M., Alvarez-Sala, L. A. et al. Red wine intake prevents nuclear factor- κ B activation in peripheral blood mononuclear cells of healthy volunteers during postprandial lipemia. *Circulation*, 102:1020–6, 2000.
- Criqui, M. H., and Ringel, B. L. Does diet or alcohol explained the French paradox? *Lancet*, 44:1719–23, 1994.
- Cuveas, A. M., Guasch, V., Castillo, O. et al. A high fat diet induces and red wine counteracts endothelial dysfunction in human volunteers. *Lipids*, 35:143–8, 2000.
- Di Castelnuovo, A., Rotondo, S., Iacoviello, L. et al. Meta-analysis of wine and beer consumption in relation to vascular risk. *Circulation*, 105:2836–2844, 2002.
- Gronbaek, M., Becker, U., Johansen, D. et al. Type of alcohol consumed and mortality from all causes, coronary heart disease, and cancer. *Ann. Intern. Med.*, 133:411–9, 2000.
- Mukamal, K. J., Jadhav, P. P., D'Agostino, R. B. et al. Alcohol consumption and hemostatic factors. Analysis of the Framingham offspring cohort. *Circulation*, 104:1367–73, 2001.
- Szmitko, P. E., and Verma, S. Red wine and your heart. *Circulation*, 104:1367–1373, 2002.
- Tanasescu, M., Hu, F. B., Willett, W. C. et al. Alcohol consumption and the risk of coronary heart disease among men with type 2 diabetes mellitus. *J. Am. Coll. Cardiol.*, 38:1836–1842, 2001.
- Wallerath, T., Poleo, D., and Li, H. Red wine increases the expression of human endothelial nitric oxide synthase. *J. Am. Coll. Cardiol.*, 41:471–8, 2003.

Altitude and Pulmonary Edema

- I. Signs and Symptoms
- II. Mechanisms
- III. Management
- IV. Clinical Study
- V. Perspective and Research Implications

GLOSSARY

hypoxia; hypoxemia severe lack of oxygen in the blood.

neutrophils white blood cells.

pulmonary edema caused by heart failure and the heart fails to eject blood forward into the aorta. Fluid that contains salt and water and components of blood flood the alveoli of the lungs and this results in severe shortness of breath.

I. SIGNS AND SYMPTOMS

High-altitude pulmonary edema, severe shortness of breath due to accumulation of fluid in air sacs of the lungs, may occur in young, healthy, susceptible adults who ascend rapidly to altitudes in excess of 2500 m. The first symptom is usually dyspnea on exertion and a reduced exercise tolerance greater than expected for the altitude. A dry and annoying cough later becomes productive with blood-stained sputum. Symptoms typically occur in the first two to four days after arrival at these high altitudes.

Symptoms may become much worse when these individuals engage in strenuous exercise at such high altitudes before they become acclimatized. Cough, shortness of breath, and reduced effort tolerance may increase within hours and progress to fulminant pulmonary edema, which is heralded by extreme shortness of breath, including shortness of breath when the individual is lying in bed (orthopnea).

On examination physical signs include fever, although this rarely exceeds 38.5°C and crepitations or crackles (rales) are heard over the chest with the stethoscope. High-altitude pulmonary edema is often accompanied by

nonspecific cerebral symptoms including headache, anorexia, nausea, vomiting, fatigue, and sleep disturbance.

Death may occur in young individuals who have no structural heart disease. The risk for pulmonary edema is related to the rapidity of ascent, the level of exertion, and individual susceptibility. The pulmonary symptoms may be accompanied by severe cerebral symptoms such as altered consciousness, ataxia, and brain herniation that progresses to coma and death. Thus individuals with symptoms of acute mountain sickness (headache, anorexia, vomiting, dizziness, and fatigue) and high altitude pulmonary edema may progress rapidly to severe cerebral symptoms and death.

II. MECHANISMS

Vasoconstriction of pulmonary vessels causes an increase in both alveolar capillary pressure and vascular fluid shear stress. Flooding of pulmonary capillaries and increased capillary permeability occur. Fluid and inflammatory cells leak into the air sacs that are normally dry. Pulmonary edema is caused by an imbalance between forces that drive water into the air sacs and the physiologic mechanisms that remove it.

A reaction to lung injury brings about chemical mediators of inflammation, vascular endothelial growth factor, interleukin-1, and tumor necrosis factor. These are released from pulmonary structural cells and alveolar macrophages. Neutrophils and platelets are trapped in the pulmonary capillaries. Fluid accumulates in the air sacs resulting in acute shortness of breath.

Hypoxia increases pulmonary vascular resistance and the pulmonary artery pressures rise. Severe exertion further increases pulmonary artery pressures.

Sartori et al. determined that the nasal transepithelial potential difference in persons who were susceptible to high-altitude pulmonary edema was 33% lower than that in individuals who were not susceptible. The susceptible individuals appear to have a defect in transepithelial sodium and water clearance in the lungs, and this may be

genetically determined. Severe sudden oxygen lack and exertion appear to render the alveolar-capillary boundary leaky, in susceptible individuals, and fluid with inflammatory cells flood the alveoli.

The process is the key to models of lung injury in which catecholamines alter sodium and fluid transport. Sartori et al. hypothesized that a beta-adrenergic agonist such as salmeterol, commonly used in the treatment of asthma, may favorably alter the defective alveolar fluid and sodium clearance. They showed that in susceptible mountaineers pretreated with inhaled salmeterol, the incidence of high-altitude pulmonary edema decreased 50% compared with control subjects.

III. MANAGEMENT

The best strategy to prevent pulmonary edema is to ascend gradually to allow sufficient time for acclimatization. Descend to a lower altitude as quickly as possible and administer a high inhaled concentration of oxygen. Simulated descent with a portable hyperbaric chamber can be lifesaving.

Prevention of pulmonary edema in people with a history of high-altitude pulmonary edema may be achieved by the use of nifedipine, a calcium antagonist that reduces pulmonary artery pressures. Slow release nifedipine 20 mg every 8 h has been shown to be effective in prevention after rapid ascent to greater than 4000 m.

Continuous positive airway pressure with a portable device is useful. Also, nifedipine 10 mg immediately, then provided that the systolic blood pressure is greater than 100 mmHg, slow-release nifedipine 20–30 mg every 12–24 h along with oxygen may be useful during descent. Nifedipine is a powerful vasodilator and antihypertensive agent that may cause severe hypotension and caution is required. The high pulmonary artery pressure is caused by hypoxemia, which must be relieved by high concentrations of inhaled oxygen.

Acetazolamide, a mild diuretic and carbonic anhydrase inhibitor, causes elimination of bicarbonate by the kidney altering the blood pH and stimulating respiration. Acetazolamide should be commenced two days prior to a planned trip to high altitudes. The drug does not prevent high-altitude pulmonary edema, but it appears to be useful in the prevention of acute mountain sickness and for high-altitude flights. The dosage should be 250 mg twice or three times daily one day before ascent. A dose lower than 750 mg daily may be ineffective for some individuals. A combination of acetazolamide and dexamethasone 8 mg daily is more effective than either drug alone. Ginkgo biloba at a dose of 80 mg twice daily has been

shown to be effective in a small study, but beneficial effects were variable in other studies in preventing acute mountain sickness.

Inhaled salmeterol commenced prior to the ascent and repeated at 2000 m is advisable based on the work of Sartori et al. This drug has an excellent safety profile and has been used in asthmatics for more than 30 years. Serevent is a long-acting salmeterol that should also be tried.

IV. CLINICAL STUDY

Study question: Beta-adrenergic agonists upregulate the clearance of alveolar fluid and attenuate pulmonary edema in animal models. The study assessed effects of prophylactic inhalation of salmeterol, a beta-agonist, on the incidence of high-altitude pulmonary edema.

Methods: These included a double-blind, randomized placebo-controlled study in 37 subjects susceptible to high-altitude edema who were assessed during exposure to high altitudes (4559 m). Nasal transepithelial potential difference was used as a marker of the transepithelial sodium and water transport in the distal airways of 33 mountaineers prone to pulmonary edema and 33 who were resistant.

Results: Prophylactic inhalation of salmeterol decreased the incidence of high-altitude pulmonary edema by more than 50%; the nasal transepithelial potential difference was also significantly changed.

Perspective: Prophylactic inhalation of salmeterol, a well-known beta-adrenergic agonist used in the management of asthma for more than 25 years, was shown to be sufficiently effective in the study and is advisable.

V. PERSPECTIVE AND RESEARCH IMPLICATIONS

High-altitude pulmonary edema is preventable. Fortunately, very few mountain climbers are susceptible, but those who are may have unpredictable recurrences when they are exposed to high altitudes. The susceptible individual must take prophylaxis including acetazolamide, nifedipine, inhaled salmeterol; ascend slowly; and avoid vigorous exertion. Considerable research is required in this area to further clarify the pathogenesis of high-altitude cerebral edema. This research would help refine more beneficial treatment. Natural products including Ginkgo biloba and garlic may be useful for the amelioration of benign symptoms of high-altitude illness. Drugs including sildenafil, which inhibits hypoxemia-induced pulmonary

hypertension, may be useful in the management of high-altitude pulmonary edema and are being studied.

BIBLIOGRAPHY

- Basnyat, B., and Murdoch, D. R. High altitude illness. *Lancet*, 361:1967–74, 2003.
- Beall, C. M. High altitude adaptations. *Lancet*, 362:s14, 2003.
- Cruden, N. L. M., Newby, D. E., Webb, D. J. et al. Salmeterol for the prevention of high-altitude pulmonary edema. *N. Engl. J. Med.*, 347:1282–1285, 2002.
- Droma, Y., Hanaoka, M., Ota, M. et al. Positive association of the endothelial nitric oxide synthase gene polymorphisms with high-altitude pulmonary edema. *Circulation*, 106:826–830, 2002.
- Hackett, P., Rennie, D. et al. High-altitude pulmonary edema. *JAMA*, 287:2275–2278, 2002.
- Maggiolini, M., Mélot, C., Pierre, S. et al. High-altitude pulmonary edema is initially caused by an increase in capillary pressure. *Circulation*, 103:2078–2083, Apr 2001.
- Pilmanis, A. A. Physiological hazards of flights at high-altitude. *Lancet*, 362:s16, 2003.
- Sartori, C., Allemann, Y., Duplain, H. et al. Salmeterol for the prevention of high altitude pulmonary edema. *N. Engl. J. Med.*, 346:1631–6, 2002.
- Voelkel, N. F. High altitude pulmonary edema. *N. Engl. J. Med.*, 346:1606–07, 2002.
- Zhao, L., Mason, N. A., Morrrell, N. W. et al. Sildenafil inhibits hypoxia-induced pulmonary hypertension. *Circulation*, 104:424–28, 2001.

Anatomy of the Heart and Circulation

- I. Anatomic Features
- II. Circulation of Blood

GLOSSARY

- atherosclerosis** same as atheroma, raised plaques filled with cholesterol, calcium, and other substances on the inner wall of arteries that obstruct the lumen and the flow of blood; the plaque of atheroma hardens the artery, hence the term atherosclerosis (sclerosis = hardening).
- capillaries** minute, thin-walled blood vessels which connect the arterioles and the venules, forming a network in nearly all organs and tissues of the body.
- coronary arteries** the arteries that supply the heart muscle and other parts of the heart with blood.
- heart** the size of a closed fist, it lies within the chest cavity, directly under the breastbone (sternum); the shape of the heart is conical with the apex pointing downward to the left edge of the diaphragm.
- myocardial infarction** death of an area of heart muscle due to blockage of a coronary artery by blood clot and atheroma; medical term for a heart attack or coronary thrombosis.
- myocardium** the heart muscle.
- tissues** an aggregation of specialized cells which together perform certain special functions.

I. ANATOMIC FEATURES

Major structural parts of the heart include the muscular wall (myocardium), the inner lining (endothelium), the outer lining (pericardium), and the blood vessels supplying the heart with blood. The coronary arteries and veins run along the surface of the heart through the pericardium and traverse the muscular wall. Anatomical features of the heart and circulation are illustrated in Figs. 1–10.

A. Muscle Wall/Myocardium

The wall of the heart consists of three layers: (1) a middle layer of muscle fibers called the myocardium; (2) an outer thin covering, the pericardium (Fig. 2) and (3) an internal lining called the endocardium that is smooth as silk. The blood of the heart rests momentarily on the endocardium before it is ejected from the heart into the aorta.

B. Pericardium

The muscle wall of the heart is surrounded by a thin but double membrane, the pericardium. The innermost or visceral layer of the pericardium is a secretory membrane that is closely attached to the surface of the heart muscle. The outer or parietal layer of the pericardium consists of a thin but tough layer. Figure 1 shows the parietal pericardium (cut). The cells of the pericardium secrete minute quantities of a lubricating fluid that separate the two layers of the pericardium. This pericardial fluid may be increased by diseases creating a pericardial effusion.

C. Chambers of the Heart

The thin-walled top chambers are called the right and left atrium, see Fig. 3. Oxygenated blood passively enters the left atrium from the lungs (Fig. 4) and deoxygenated blood returns from the lower extremities, abdomen, trunk, and the head region and enters passively into the right atrium. The lower chambers are called the right and left ventricles. The left ventricle is thick-walled because the strong muscle is needed to pump the blood to all parts of the body. The right ventricle is thin-walled because only a small amount of force is required to pump the blood from the right ventricle through the lungs and return the blood to the

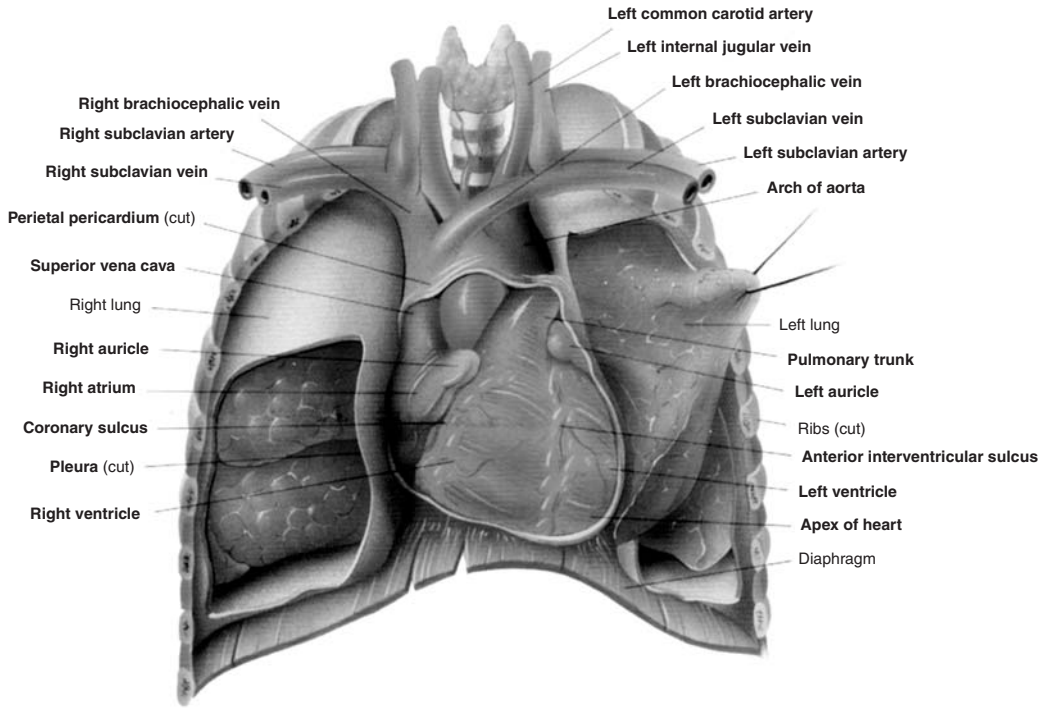

FIGURE 1 The heart in relation to surrounding structures. (Source: Gaudin, A.J., and Jones, K.C. (1989). "Human Anatomy and Physiology." Harcourt Brace Jovanovich, San Diego, p. 559. Reproduced with permission.)

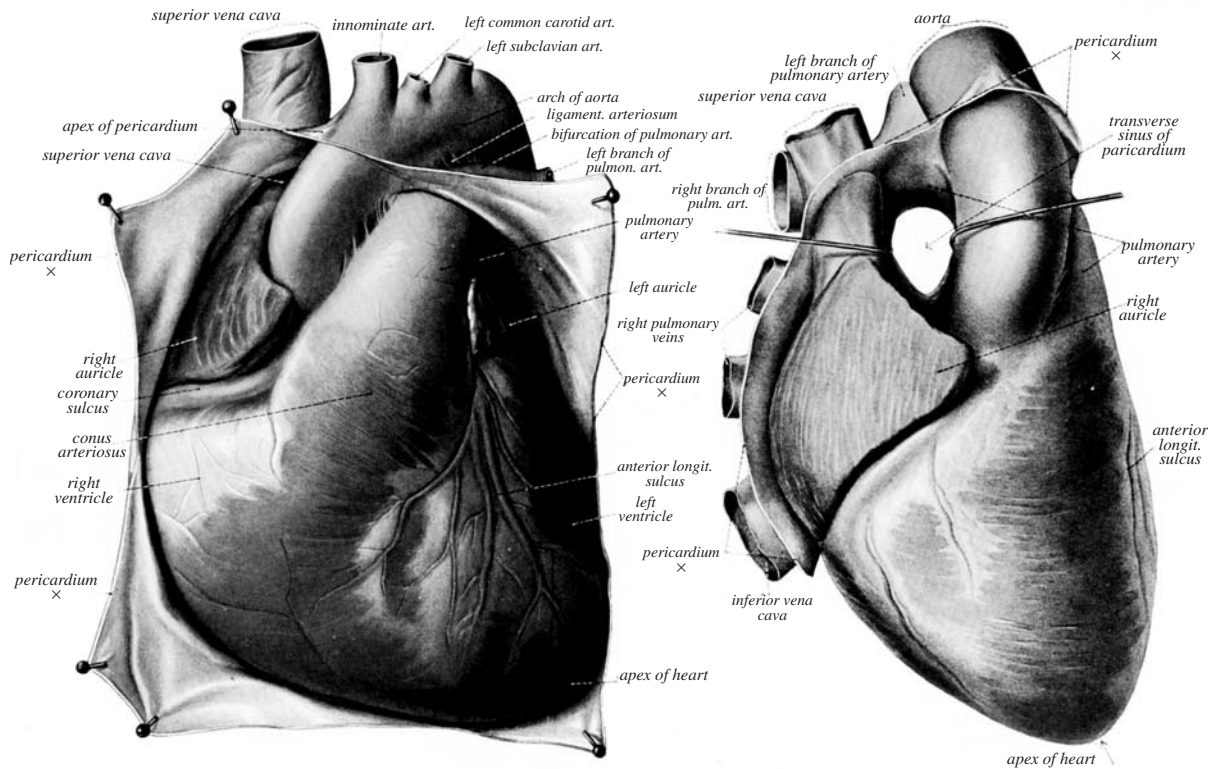

FIGURE 2 (Source: Sobotta, J., and McMurrich, J.P., *Atlas of Human Anatomy*, Philadelphia: W. B. Saunders, 1911. With permission.)

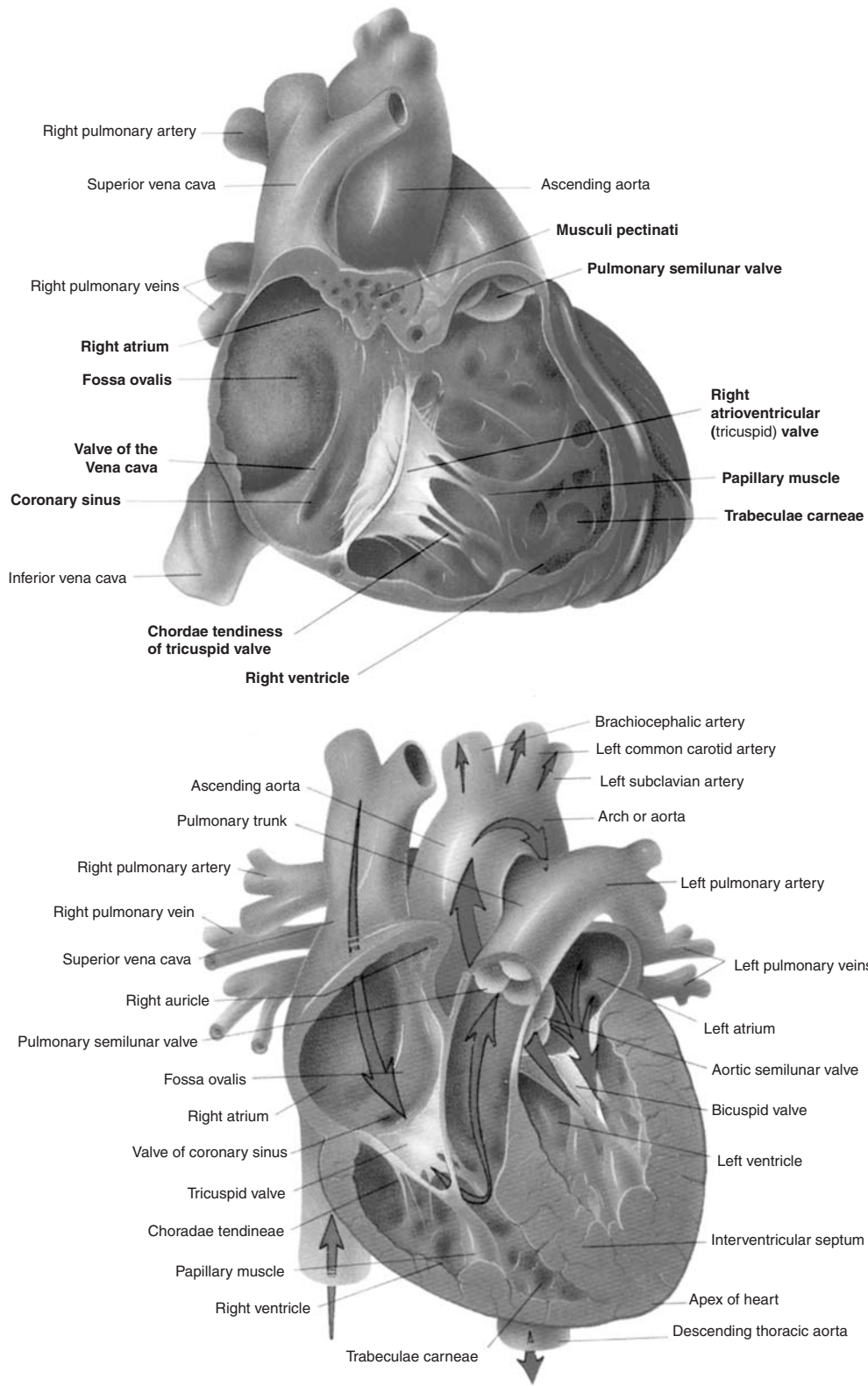

FIGURE 3 The internal anatomy of the heart. (Source: Gaudin, A.J., and Jones, K.C. (1989). "Human Anatomy and Physiology." Harcourt Brace Jovanovich, San Diego, p. 565. Reproduced with permission.)

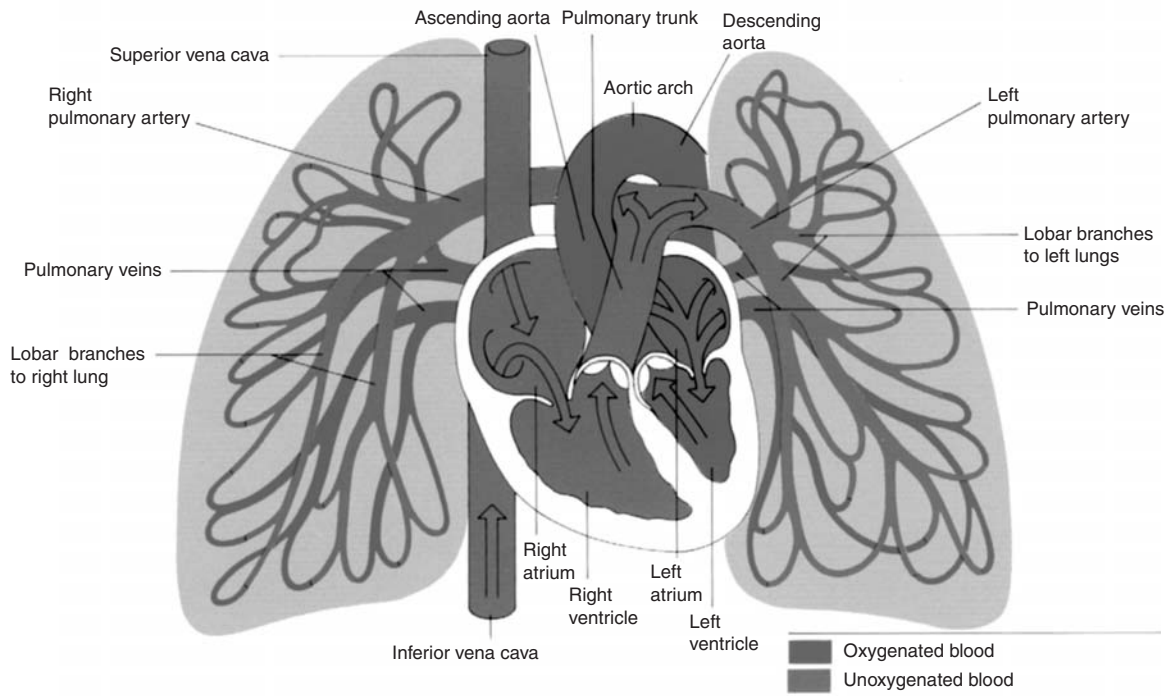

FIGURE 4 Pulmonary circulation. (Source: Gaudin, A.J., and Jones, K.C. (1989). "Human Anatomy and Physiology." Harcourt Brace Jovanovich, San Diego, p. 589. Reproduced with permission.)

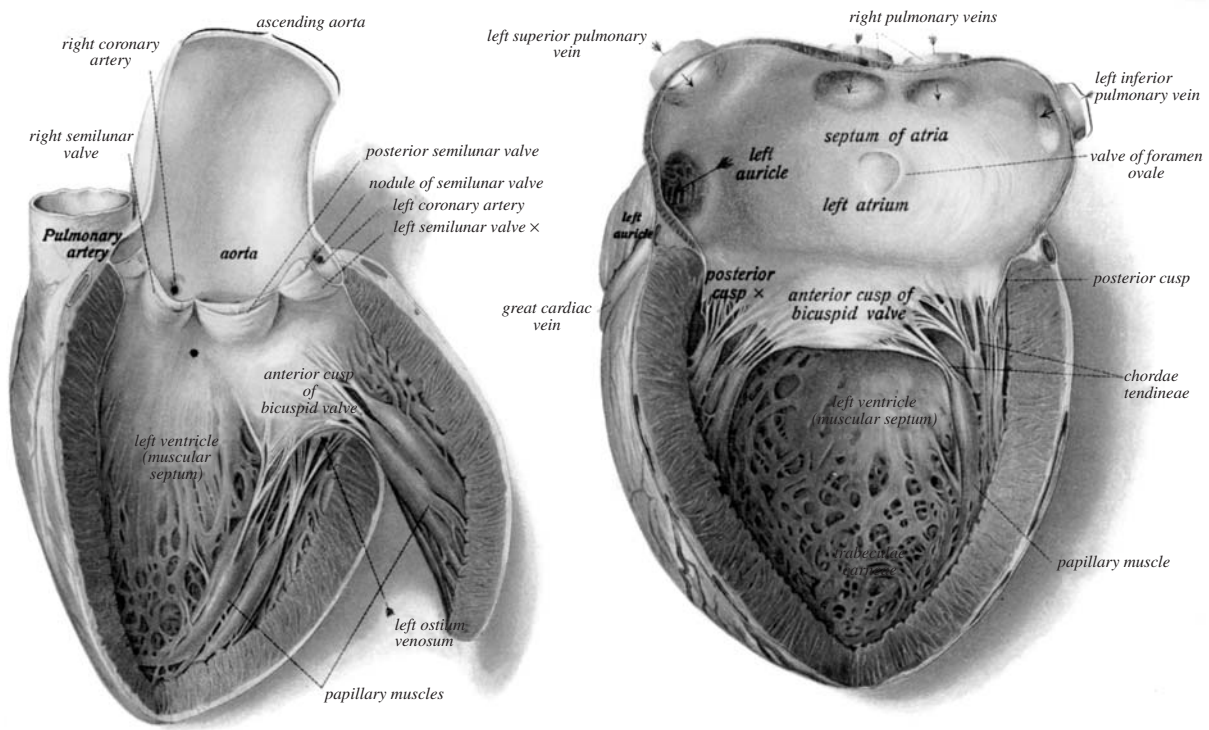

FIGURE 5 (Source: Sobatta, J., and McMurrich, J.P., *Atlas of Human Anatomy*, Philadelphia: W. B. Saunders, 1911. With permission.)

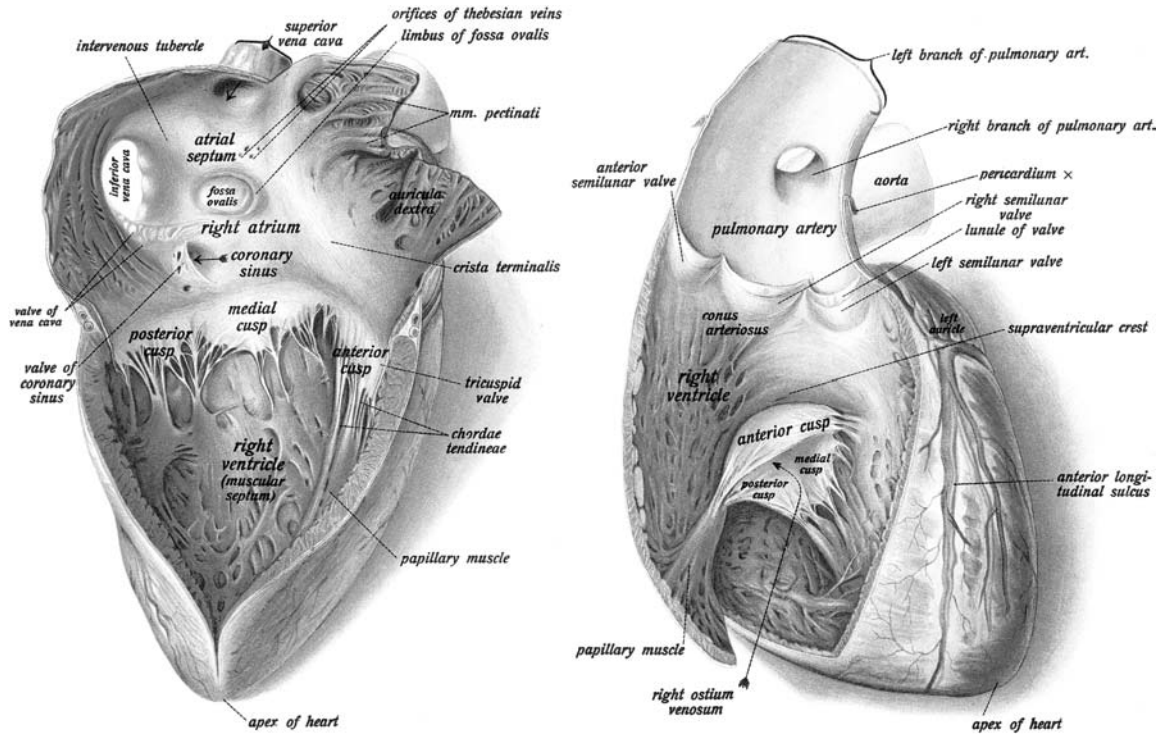

FIGURE 6 (Source: Sobatta, J., and McMurrich, J.P., *Atlas of Human Anatomy*, Philadelphia: W.B. Saunders, 1911. With permission.)

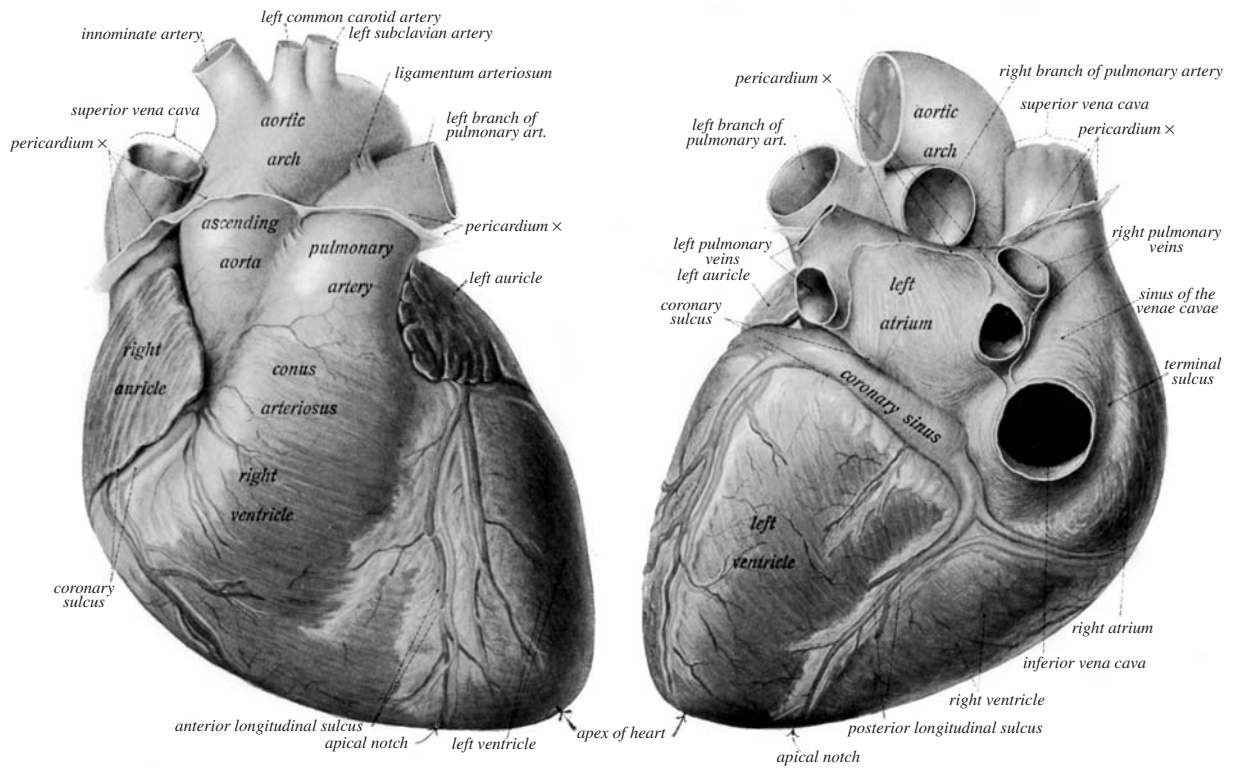

FIGURE 7 (Source: Sobatta, J., and McMurrich, J.P., *Atlas of Human Anatomy*, Philadelphia: W.B. Saunders, 1911. With permission.)

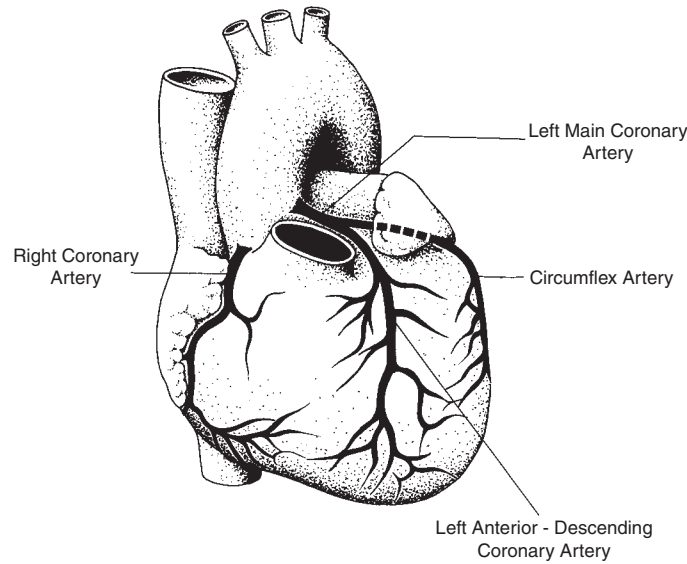

FIGURE 8 Coronary arteries. (Source: Khan, M. Gabriel, *Heart Trouble Encyclopedia*, Toronto: Stoddart, 1996. With Permission)

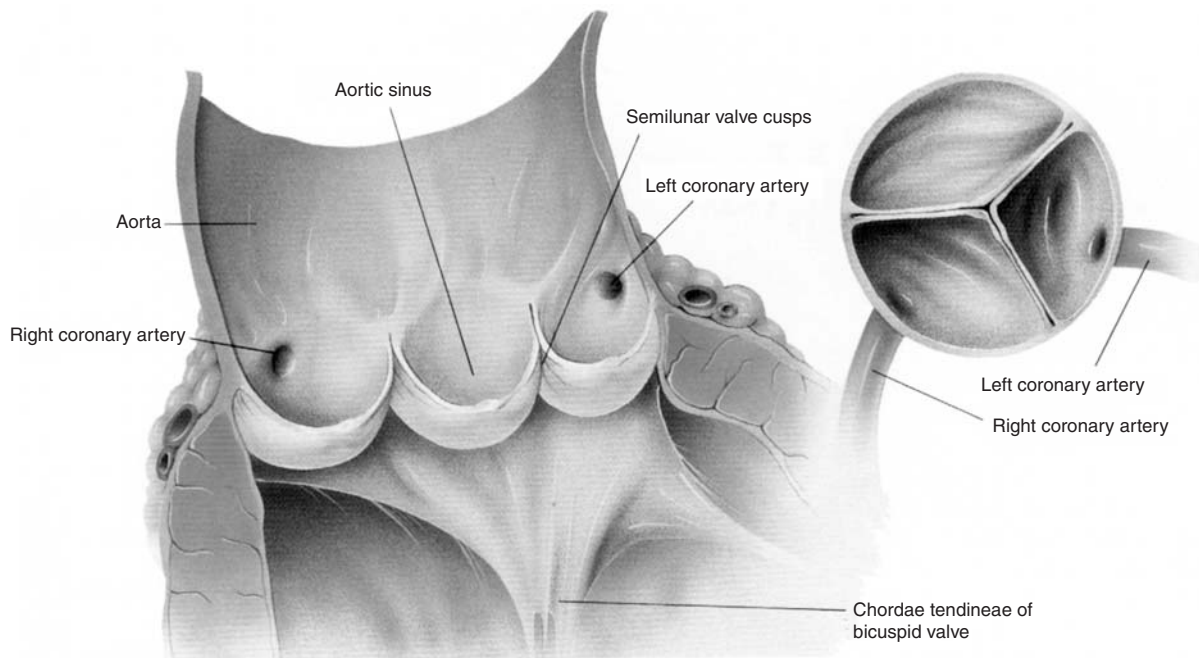

FIGURE 9 The aortic semilunar valve. (Source: Gaudin, A.J., and Jones, K.C. (1989). "Human Anatomy and Physiology." Harcourt Brace Jovanovich, San Diego, p. 566. Reproduced with permission.)

left atrium. The right and left atria are separated from each other by a thin membrane called the atrial septum. The right and left ventricles are separated by a thicker muscular structure called the interventricular septum (see Figs. 2 and 4). The right and left atria are separated from the right and left ventricles by the tricuspid and mitral valves (mitral valve = bicuspid valve in Figs. 3 and 5), respectively. The

outflow from the left ventricle is separated from the aorta by the aortic valve (Figs. 2, 5 and 9).

The aorta, the largest artery in the body (Figs. 3, 5, and 7), leaves the heart and takes blood ejected from the heart to the rest of the body. The blood from the right ventricle is ejected through the pulmonary valve into the pulmonary artery, which traverses the lung (Figs. 3, 4, 6,

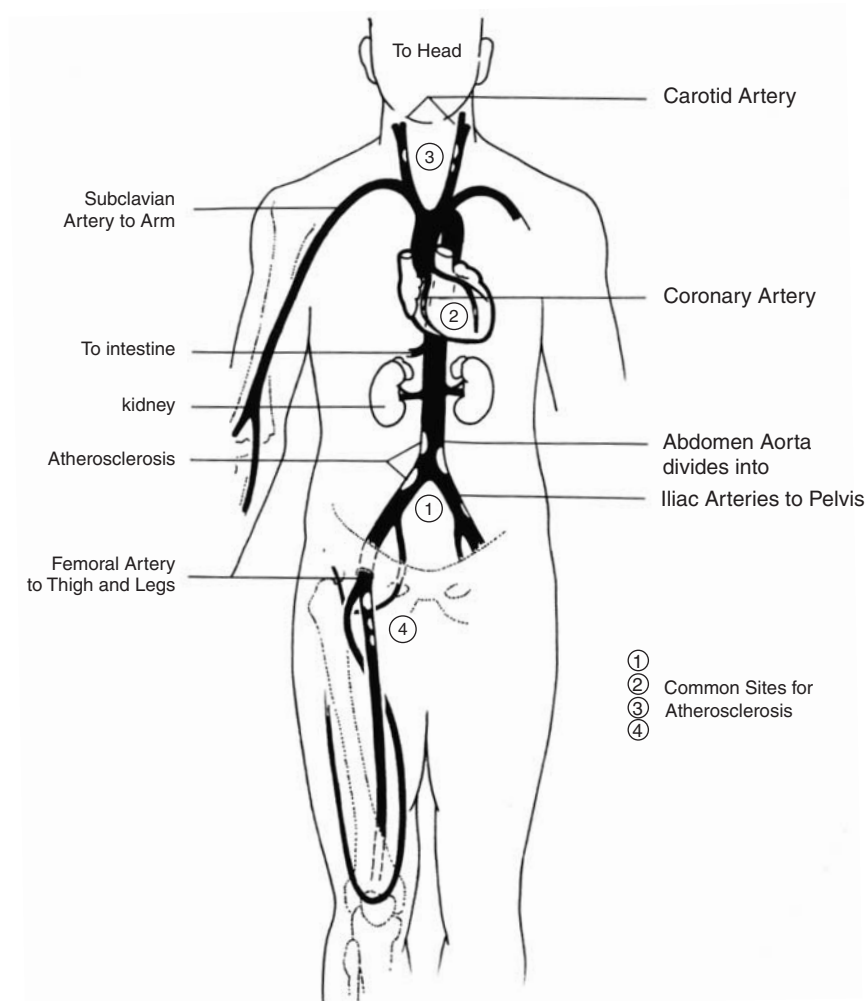

FIGURE 10 The heart and arteries.

and 7). Blood is returned from the lungs to the left atrium via the thin-walled pulmonary veins.

The heart valves open and close to allow the heart chambers to fill with blood and to allow blood to be ejected during systole or contraction of the heart. The leaflets of the valves are smooth but may become thickened by diseases such as rheumatic fever, which may lead to leaking or tight (stenotic) valves.

D. Coronary Arteries

There are two main coronary arteries, left and right, which originate from the root of the aorta as it leaves the heart (see Figs. 5 and 8). Arteries are tubes which carry blood from the heart. The channel within the tube is the lumen of the artery. The branches of the two main arteries carry oxygen and nutrients to the heart muscle and cells.

As shown in Fig. 8, the coronary arteries run along the outer surface of the heart. The left main coronary artery is very short, 0.2–4 cm, and divides almost immediately into two branches. The first branch, called the anterior descending artery, runs down the front surface of the heart near the undersurface of the left margin of the breastbone. It supplies blood to a major portion of the left ventricle. The second branch, called the circumflex artery, circles around and feeds the back of the heart. The right coronary artery leaves the aorta, veers sharply left, then is directed toward the breastbone and curves downward to run along the border of the right ventricle. The right coronary artery supplies branches to the electrical system, which involves special cells that cause the heart to beat (the sinus node or pacemaker), and to the conducting bridge for electrical transmission between the atrium and ventricle (atrioventricular (AV) node). The branches subdivide several times and perforate the heart muscle at different points to bring

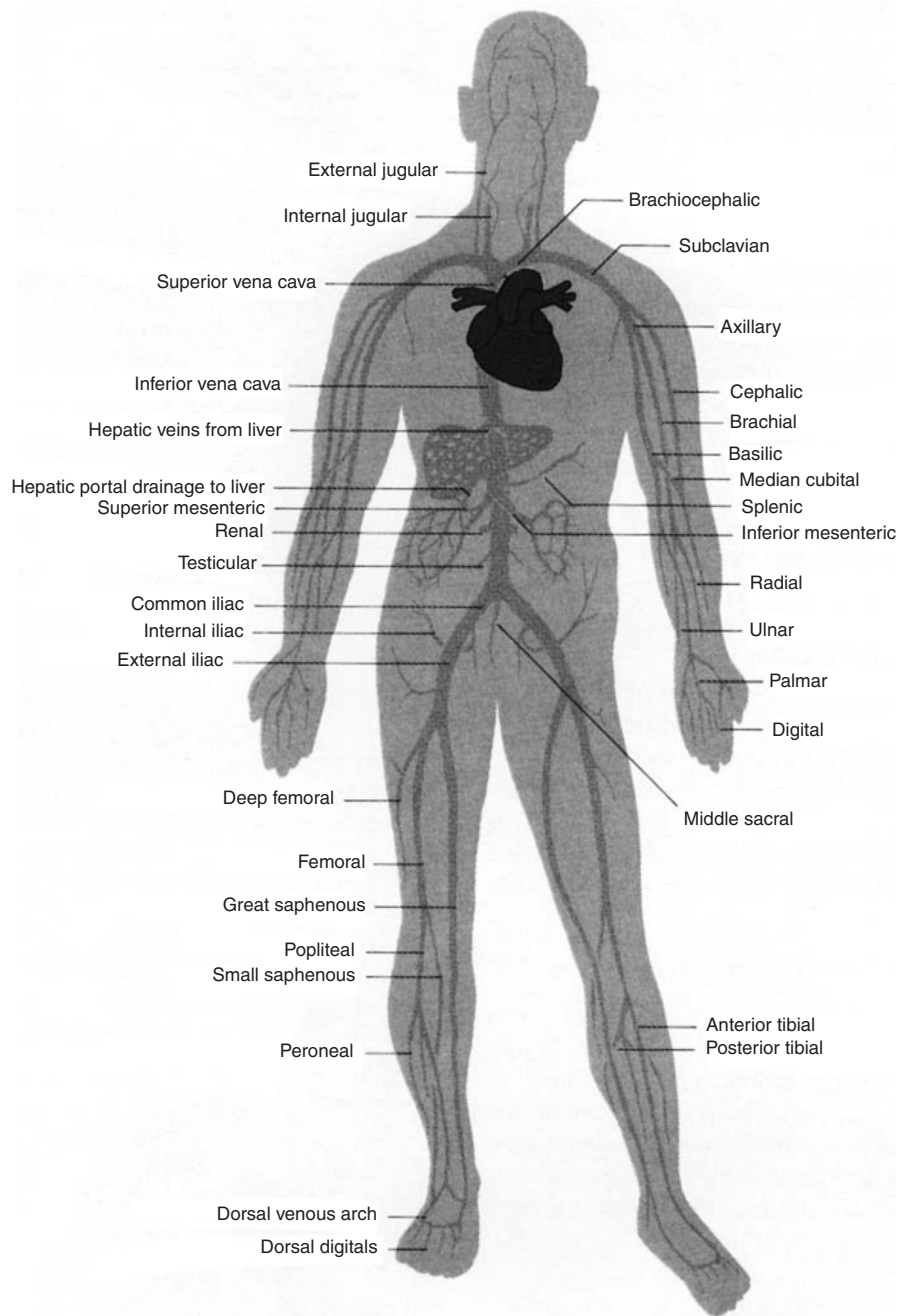

FIGURE 11 Systemic veins. (Source: Gaudin, A.J., and Jones, K.C. (1989). "Human Anatomy and Physiology." Harcourt Brace Jovanovich, San Diego, p. 598. Reproduced with permission.)

nutrients to the muscle. These arteries have nothing to do with the blood flow inside the heart, which is pumped around the body. In addition, their internal diameter is only about the size of a soda straw, thus, they are easily obstructed. When the coronary arteries are completely obstructed, a heart attack (myocardial infarction) results.

Consider the heart as being supplied by four arteries, the left main coronary artery, the left anterior descending, the circumflex, and the right coronary artery (see Fig. 8). It is easy to visualize blockage of the left main coronary artery as the most dangerous, as it would block off two major arteries. Fortunately, this occurrence is rare. Most heart attacks block the right coronary artery,

the anterior descending, and less common, the circumflex or smaller branches of all three arteries (see the chapters Heart Attacks and also Atherosclerosis/Atherothrombosis).

II. CIRCULATION OF BLOOD

A. The Heart is a Simple Pump

The human heart is a muscular pump. Its function is to pump blood containing oxygen, glucose, protein, fat, and salts to every organ, tissue, and living cell of the body. The heart is divided into four chambers. The upper chambers are called the right and left atrium, and the lower chambers are called the right and left ventricles. Blood from all parts of the body drains into veins that empty into the right atrium. Blood passes from the right atrium through the tricuspid valve and reaches the right ventricle. During contraction of the right ventricle, blood is pushed into the lungs where it gives off CO_2 , takes up oxygen, and returns via the pulmonary veins to the left atrium (Fig. 4).

During relaxation or diastole of the left ventricle, blood passes from the left atrium through the mitral valve (labeled bicuspid in Figs. 3 and 5) to reach the left ventricle. When the left ventricle contracts simultaneously with the right, about 70 ml of blood is ejected with each heartbeat through the aortic valve into the aorta. The blood is then circulated through the branches of the aorta that form the arterial system supplying blood to organs and tissues of the body.

If the heart beats 70 times per minute, it produces an output from the heart of approximately 5 L of blood per

minute. This is called the cardiac output. Each 70 ml of blood is propelled through approximately 100,000 km of blood vessels. The heart beats about 2.5 billion times during an average lifespan, pumping more than 227 million L of blood. Fortunately, the heart muscle is one of the strongest in the body. It can maintain efficient pumping and life for more than 100 years provided the coronary arteries that feed the muscle with blood do not become blocked by hardened plaques or a blood clot. Unfortunately, the coronary arteries are very narrow and are easily obstructed by plaques containing cholesterol, calcium, and other constituents (see the chapter Atherosclerosis/Atherothrombosis).

B. Systemic Circulation

The systemic circulation is the part of the vascular system that carries blood from the left ventricle to organs and tissues of the body. As outlined above, the aorta is the major artery of the systemic circulation. It extends down the length of the chest and abdomen and reaches the pelvis dividing into two branches, the iliac arteries (see Fig. 10). Veins collect blood from the capillaries of tissues and organs (see Fig. 11). The large veins drain into the superior and inferior vena cavae that return blood to the right atrium.

BIBLIOGRAPHY

Gaudin, A. J., and Jones, K. C. *Human Anatomy and Physiology*. Harcourt Brace Jovanovich, San Diego, 1989.

Anderson-Fabry Disease

GLOSSARY

hypertrophy increase in thickness of muscle.

valvular pertaining to the heart valves.

THIS DISEASE IS A RARE, INBORN X-LINKED lysosomal storage disorder. The major substrate of the deficient alpha-galactosidase A enzyme, globotriaosylceramide, accumulates in cells of the cardiovascular system. This leads to structural valvular abnormalities and enlargement of the heart with left ventricular hypertrophy, particularly in patients over age 40. The heart muscle involvement includes cardiomyopathy, but

it may be the only manifestation of this disease. Genetic abnormalities are X-linked and clinical manifestations in female heterozygotes are rare. Serious clinical disease, fortunately, only affects less than 2% of heterozygous females.

A new therapeutic strategy for treatment of lysosomal storage diseases with enzyme replacement therapy has become available.

BIBLIOGRAPHY

Kampmann, C., Baehner, F., Whybra, C. et al. Cardiac manifestations of Anderson Fabry disease in heterozygous females. *J. Am. Coll. Cardiol.*, 40:1668-74, 2002.

Anemia and the Heart

- I. Anemia and Heart Function
- II. Clinical Studies

GLOSSARY

- angina** chest pain caused by temporary lack of blood to an area of heart muscle cells, usually caused by severe obstruction of the artery supplying blood to the segment of cells.
- arrhythmia** general term for an irregularity or rapidity of the heartbeat, an abnormal heart rhythm.
- cardiac dysfunction** the normal function of the heart is reduced; abnormal heart function.
- creatinine** breakdown of proteins excreted into the urine by the kidneys so that the composition in the bloodstream remains relatively constant.
- ejection fraction** the fraction of blood ejected from the heart into the arteries, normally this ranges from 60 to 75%; a low ejection fraction is less than 40%.
- heart failure** a failure of the heart to pump sufficient blood from the chambers into the aorta; inadequate supply of blood reaches organs and tissues.
- hypotension** marked decrease in systolic blood pressure, usually less than 95 mmHg (normal pressure range 100 to 140 mm Hg)
- ischemia** temporary lack of blood and oxygen to an area of cells, for example, the heart muscle, usually due to severe obstruction of the artery supplying blood to this area of cells.
- myocardium** the heart muscle.

I. ANEMIA AND HEART FUNCTION

The heart and the circulating system through arteries, veins, and capillaries must accomplish two goals: (1) delivery of oxygen and nutrients to organs and the peripheral tissues and (2) removal of metabolic waste products that accumulate throughout the body. Oxygen is carried by hemoglobin in red blood cells to the tissues. The normal level of hemoglobin in circulating blood is 11.5–15.5 g/dl (115–155 g/L) in women and 15 to 17 g/dl in men.

A normal structural heart with normal function can tolerate a hemoglobin of 7 g/dl for approximately one year without causing cardiac damage or heart failure. Levels of 6 g/dl or less may cause cardiac dysfunction after approximately 6 months. In patients with angina, chest pain may be precipitated because lack of oxygen to the myocardium produces myocardial ischemia that causes pain.

Patients with sickle cell anemia commonly have a hemoglobin in the range of 7–8 g/dl. In these individuals cardiac enlargement with dilation occurs early in the course of the disease. Because of the anemia and poor delivery of oxygen to tissues, cardiac output increases to compensate and deliver the supply of nutrients. This entails more work for the heart. By age 40 these individuals manifest symptoms of poor cardiac function.

II. CLINICAL STUDIES

Study question: Mild anemia occurs commonly in patients with heart failure, the detrimental effects of mild to moderate anemia on cardiac function and the effect of correction has not been adequately addressed by controlled studies. Many studies consider anemia to be a rare precipitating cause of heart failure and of hospitalization for heart failure. Silverberg et al. studied the effect of correcting anemia with erythropoietin (EPO) and intravenous iron.

Methods: Patients (32) with moderate to severe heart failure class III to IV, and left ventricular ejection fraction of less than 40%, despite optimal doses of heart failure medications and with a hemoglobin level between 10 and 11.5 g/dl were randomized. Group A received subcutaneous EPO and intravenous iron to increase the hemoglobin level to >12.5 g/dl. Group B received no treatment for the anemia.

Results: Over a mean follow up of 8 months, 4 patients in group A died of heart failure. New York heart Association class improved by 42% in A and worsened by 11% in B. The ejection fraction improved approximately 5% in A and decreased approximately 5% in B.

The serum creatinine did not change in A but increased by 20% in B. Most important, the need for oral and intravenous furosemide decreased by 51 and 91%, respectively, in A, but increased 20%, respectively, in B. Length of hospital stay decreased significantly in A (79%), but increased 57% in B.

Horwich et al. analyzed a cohort of 1061 patients with severe heart failure. The survival at one year was higher in patients with increased hemoglobin levels. They concluded that in chronic heart failure relatively mild degrees of anemia are associated with worsened symptoms, functional class, and survival.

Mozaffarian et al., using a prospective cohort design, evaluated the relationship between baseline serum hematocrit and mortality among 1130 patients with a left ventricular ejection fraction less than 30% treated with ACE inhibitors, diuretics, and digitalis. Follow up at 15 months showed 407 deaths in those with a hematocrit of 25–37%; these patients had a 52% higher risk of death compared with those with a normal hematocrit of 46–58%. In patients with severe heart failure, anemia is a significant independent risk factor for death with a progressively higher risk with increasing severity of anemia. The etiology, prevention, and treatment of anemia in severe heart failure require further investigation to improve survival rates.

Correction of anemia in patients with heart failure has been shown in this study to be most beneficial. Treatment with EPO and intravenous iron caused marked improvement in heart function and was associated with a significant reduction in hospitalization, renal impairment, and the need for diuretics. Correction of the anemia

also enhances the standard therapy for heart failure. Silverberg et al. stated that it is surprising, judging from the literature on heart failure, that such an obvious treatment for improving heart failure is so rarely considered.

BIBLIOGRAPHY

- Anand, I., McMurray, J. J. V., Whitmore, J. et al. Anemia and its relationship to clinical outcome in heart failure. *Circulation*, 110:149–154, 2004.
- Ezekowitz, J. A., McAlister, F. A., Armstrong, P. W. et al. Anemia is common in heart failure and is associated with poor outcomes: Insights from a cohort of 12,065 patients with new-onset heart failure. *Circulation*, 107:223–225, 2003.
- Horwich, T. B., Fonarow, G. C., Hamilton, M. A. et al. Anemia is associated with worse symptoms, greater impairment in functional capacity and a significant increase in mortality in patients with advanced heart failure. *J. Am. Coll. Cardiol.*, 39:1780, 2002.
- Ishani, A., Weinhandl, E., Zhao, Z., Gilbertson, D. T., Collins, A. J., Yusuf, S., Herzog, C. A. et al. Angiotensin-converting enzyme inhibitor as a risk factor for the development of anemia, and the impact of incident anemia on mortality in patients with left ventricular dysfunction. *JACC*, 45:391–399.
- Mancini, D. M., Katz, S. D., Lang, C. C. et al. Effect of erythropoietin on exercise capacity in patients with moderate to severe chronic heart failure. *Circulation*, 107:294–299, 2003.
- Mozaffarian, D., Nye, R., and Levy, W. C. Anemia predicts mortality in severe heart failure. *J. Am. Coll. Cardiol.*, 41:19, 33–9, 2003.
- Schroeksnadel, Wirlleitner, K. B., Fuchs, D. et al. Anemia and congestive heart failure response. *Circulation*, 108:41–42, 2003.
- Silverberg, D. S., Wexler, D., Sheps, D. et al. The effect of correction of mild anemia in severe resistant congestive heart failure using subcutaneous erythropoietin and intravenous iron: A randomized controlled study. *J. Am. Coll. Cardiol.*, 37:1775, 2001.

Aneurysm

- I. Abdominal Aortic Aneurysm
- II. Thoracic Aortic Aneurysm
- III. Aortic Dissection
- IV. Berry Aneurysm

GLOSSARY

aneurysm a ballooning of the wall of an artery or the heart caused by severe weakening of the walls of the artery or the heart muscle.

atheroma same as atherosclerosis, raised plaques filled with cholesterol, calcium, and other substances on the inner wall of arteries that obstruct the lumen and the flow of blood; the plaque of atheroma hardens the artery, hence the term atherosclerosis (sclerosis = hardening).

heart failure failure of the heart to pump sufficient blood from the chambers into the aorta; inadequate supply of blood reaches organs and tissues.

hypotension marked decrease in systolic blood pressure, usually less than 95 mmHg.

intima the innermost lining of the vessel wall that is in contact with flowing blood.

media the middle wall of arteries.

syncope temporary loss of consciousness caused by lack of blood supply to the brain; fainting describes a simple syncopal attack.

wall tension force exerted on the vessel or chamber wall acting to pull it apart in a circumferential direction; it is a function of the radius and the pressure within the lumen or chamber.

THE LARGEST ARTERY IN THE BODY IS THE aorta, which takes blood from the heart and runs from the chest into the abdomen, lying against the spine until it reaches the pelvis. It divides at that point into iliac arteries that supply blood to the pelvis, buttocks, and legs (see Fig. 1). Because the aorta takes the full force of blood ejected from the heart, it is the most likely artery in the body to weaken.

I. ABDOMINAL AORTIC ANEURYSM

A. Pathogenesis

The abdominal aorta is commonly affected by atheroma and the process of atherosclerosis (see chapter Atherosclerosis/Atherothrombosis). Atherosclerotic disease causes thickening of the intima. This thickening appears to reduce the diffusion of oxygen and nutrients from the aortic lumen to the strong middle wall of aorta. This causes degeneration of the elastic elements and weakening of the walls of the aorta. The elastic wall of the aorta may be stretched causing the vessel to dilate. Tension on the dilated aortic wall increases, thus, causing further expansion of the artery with aneurysmal formation. Tension in the dilated vessel wall rises in accordance with Laplace's law, which states that wall tension is proportional to the product of pressure and radius; as the diameter of the aorta increases its wall tension rises. The torrential blood flow imparts considerable hydrodynamic stress on the arterial wall, especially in the lower abdominal aorta.

Most aneurysms occur in the abdomen just after the aorta branches to the kidney and before the aorta ends in its division into iliac arteries to the pelvis (see Fig. 1). Fortunately, aneurysms that occur before the aorta branches off to the kidney are rare; at this location repair of an aneurysm is fraught with danger as kidney failure may occur. Other sites for aneurysmal formation are in the thoracic aorta, the iliac arteries in the pelvis, and the popliteal artery at the back of the knee.

Although hypertension, hyperlipidemia, and smoking are considered risk factors for the expansion of aneurysms, only smoking has been identified as a consistent risk factor; smoking increases the growth rate by 20–25%. Data from a study by Brady et al. including 1743 patients followed prospectively indicated that blood pressure and cholesterol levels did not predict the rate of expansion; aneurysms expanded significantly faster in current smokers than in former smokers. In addition, other studies indicated that the risk of rupture and the risk of death due to rupture are higher among current smokers than among former

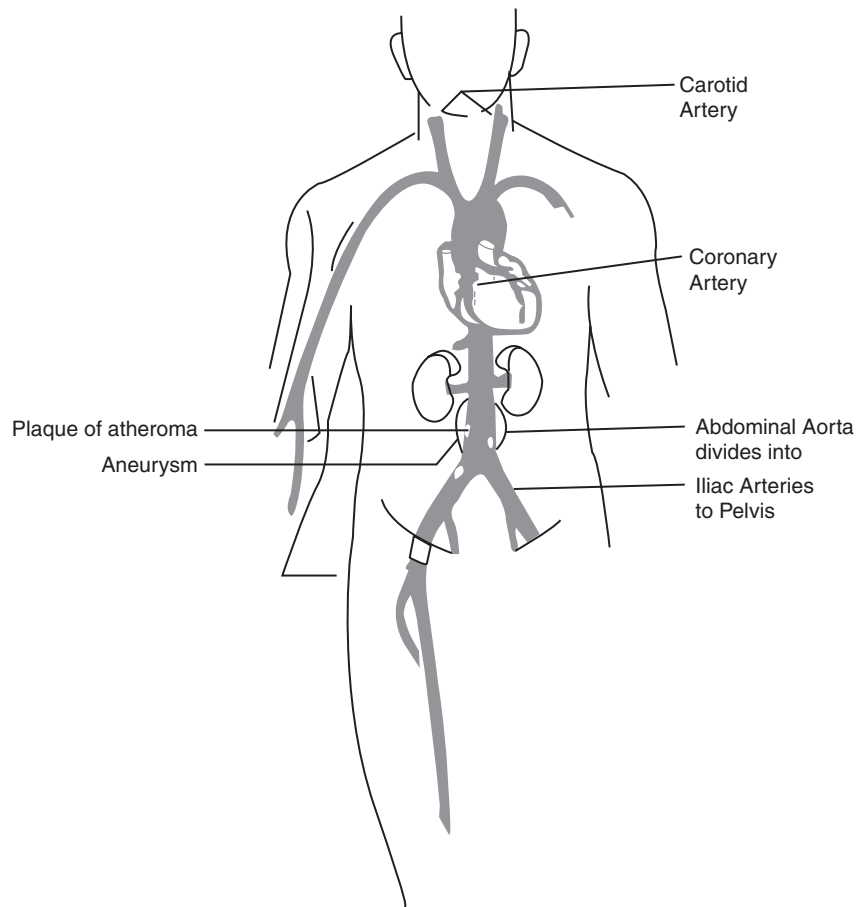

FIGURE 1 Aneurysm.

smokers and patients who never smoked by as much as a factor of 14 for smokers.

Weakening of arteries may occur because of loss of elasticity of the aortic wall due to aging. Another disease that affects the aortic wall is cystic medial necrosis, and this appears histologically as smooth muscle cell necrosis and degeneration of elastic layers within the media. The cause of the disease is unknown and mostly affects the thoracic aorta. Virtually all patients with Marfan syndrome develop cystic medial necrosis disease and many, at a young age, develop aneurysms that occur mainly in the ascending aorta, where the aorta originates from the heart.

Studies indicate that there is a familial, genetic incidence of abdominal aortic aneurysms. Screening of siblings older than 50 years of age of patients with aneurysms revealed an occult aneurysm in approximately 30% of brothers and less than 10% of sisters. The prevalence of abdominal aortic aneurysms (3–6 cm) is approximately 3 and 5% in individuals older than 55 and 65, respectively. The prevalence among men is about five times that among women. Studies suggest that one-time ultrasound

screening of men at age 65 is sufficient to identify nearly all those who are at risk. At this age men who have aortic diameters less than 2.6 cm are all expected to be free from significant aneurysm (less than 4 cm) 12 years later.

B. Signs and Symptoms

The occurrence of abdominal aortic aneurysms is common in men over age 55 and in women after age 70. Aneurysms may grow to more than 5 cm without causing symptoms and may go unnoticed by the individual. Abdominal aortic aneurysms, however, are not always asymptomatic. Back pain, abdominal pain, and particularly intermittent claudication in men greater than age 65 may be the clue to the presence of an abdominal aortic aneurysm. Selective screening for aneurysms in patients with intermittent claudication nearly doubles the yield over screening in the general population.

The asymptomatic mass may be detected by deep manual palpation of the central abdomen below or above the umbilicus. The majority of aneurysms are not detected

by palpation and they are particularly obscured by body habitus. Occasionally mild abdominal pain radiating to the low back occurs. This mild pain usually has a constant, gnawing quality and may last for hours or days. Pain of new onset or progressive increase in the intensity of pain may indicate expansion of the aneurysm or impending rupture. The rupture of an abdominal aneurysm is usually accompanied by increasing severity of pain, lower blood pressure, hypotension, and a pulsatile mass in the central abdomen. The patient is usually anxious, sweaty, and in distress.

A simple ultrasound of the abdomen detects all abdominal aneurysms and gives a good estimate of their size. Screening is recommended mainly in patients at risk. The normal diameter of the aorta is 1.8–2 cm. Approximately 10% of men have an aortic diameter of more than 2.9 cm by age 65. An aneurysm is indicated by an aortic diameter of 3 cm or greater. Aneurysms are significant when they are greater than 4 cm in diameter and from this stage must be followed closely every six months with ultrasonography. A CT is even more accurate and can determine the size of aneurysms to within a diameter of ± 2 mm. Aneurysms more than 4 cm have less than a 2% risk of rupture, but those larger than 5.5 cm have a more than a 20% risk of rupture within 2 years; the risk is considered relatively low with aneurysms less than 5 cm.

C. Treatment

Patients with aneurysms less than 4 cm are managed conservatively and should be given a beta-blocking drug that reduces blood pressure and more important, decreases cardiac ejection velocity and hydrodynamic stress on the arterial wall. The systolic blood pressure should be kept lower than 140 mmHg, and diastolic less than 85 mmHg with the use of a beta-blocker and other antihypertensive agents. Propranolol should not be used in smokers because the drug is rendered ineffective.

Aneurysmal repair is usually indicated when aneurysms are greater than 5.5 cm because of the high risk of rupture and an overall mortality rate of more than 80%. Only 10–15% of patients survive the rupture. Patients who manage to reach a hospital have a 50% mortality rate. All vascular surgeons would recommend repair of aneurysms 6 cm or larger.

I. Surgical Treatment

Repair consists of opening of the aneurysm and inserting a synthetic prosthetic tube graft, usually fabricated of Dacron or expanded polytetrafluoroethylene

(Gore-Tex). Operative mortality is approximately 5% overall for effective repair, but it is less in low-risk patients. Operative mortality reaches 50% for repair of a ruptured aneurysm.

2. Endovascular Stent Grafts

During the past decade a noninvasive but costly technique, endovascular abdominal aortic aneurysm repair, has gained some acceptance following the first Russian description of the experimental procedure in 1986. In 1991, Parodi introduced this minimally invasive percutaneous approach used to exclude blood flow through abdominal aortic aneurysms. The bypass excludes blood flow through the aneurysm which shrinks over time, and the risk of rupture is lessened. This technique involves minor surgery. A modular, bifurcated endovascular graft is introduced through an artery in the leg and is advanced to occlude and bypass the aneurysm. Since Parodi's description, several types of endovascular grafts have been tested in Europe and the United States with the Food and Drug Administration's (FDA) approval. The number of failures indicates the preponderance of newer types of grafts.

Endovascular graft deployment requires radiological and surgical skills. A stent graft system is introduced through the femoral artery and either self- or balloon-expanding stents are used to trap a Dacron prosthesis with the proximal end precisely below the renal artery. Some devices use hooks and barbs to secure better fixation and prevent device migration; stents in the wall facilitate fixation to the iliac artery.

This repair succeeds in excluding the aneurysm from circulation while allowing blood to flow through the prosthetic stent graft lumen to the distal aorta and iliac vessels to the legs. This represents a major breakthrough because many patients with aneurysms are elderly and have other diseases, particularly prior heart attacks and heart failure, which carry an increased risk for major surgical intervention.

Unfortunately, less than 50% of patients have aneurysm anatomy that is suitable for endovascular grafts. More than 90% of females are rejected because of anatomical criteria that include a smaller iliac artery diameter and aortic pathology, but the more common criteria is encroachment of the aneurysm on the renal arteries. In addition, there are several problems encountered that include a high incidence of endovascular leaks and approximately 5% of patients have aneurysms that continue to grow; 1% of patients may go on to rupture their aneurysm.

Many devices have been introduced and have become obsolete within a couple of years because no engineer or manufacturer has been able to resolve the issue of

endoleaks. Also biomaterial failure because of poor graft design leading to stent fractures, graft limb thrombosis, and iliac limb dislodgment may occur in modular grafts. The FDA issued a public health warning because of serious adverse events that occurred with approved products in 2002; a similar warning was given in the UK.

At present there is no evidence from clinical trials that the risk of rupture of an aneurysm is reduced following endovascular stent grafting. The risk of rupture is 1% per year, similar to the risk in patients who have not undergone surgery and are followed by ultrasonography. No large randomized clinical trial has convincingly documented that this repair technique confers a mortality benefit either preoperatively or long term compared to surgical repair. Most reports stem from single center, nonrandomized studies, but randomized trials comparing endovascular repair with surgery are now in progress. This technology requires further refinement to be generally acceptable. When the refinements are made, it will be useful in the elderly and in patients with comorbid conditions who are at high risk for surgery.

D. Clinical Studies

1. Lederle et al.

Study question: Does elective surgical repair of small abdominal aneurysms improve survival?

Methods: Patients 50–79 years old with abdominal aneurysms of 4–5.4 cm in diameter who did not have a high surgical risk (569 patients) underwent surveillance by means of ultrasonography or CT every six months with repair reserved for aneurysms that became symptomatic or enlarged to 5.5 cm (567 patients).

Results: After a mean of 4.9 years of follow up, death from any cause in the two groups was not significantly different. Trends in survival did not immediately favor any of the prespecified subgroups defined by age or diameter of aneurysm of entry. These findings were obtained despite a low total surgical mortality of 2.7%. Eleven patients, 0.6% a year, in the conservatively treated group had rupture of aneurysms resulting in seven deaths.

Conclusion: Survival is not improved by elective repair of abdominal aneurysms smaller than 5.5 cm, even when operative mortality is low.

2. The UK Small Aneurysm Trial Participants

Study question: Which therapy is best, immediate repair or surveillance of small abdominal aneurysms?

Methods: In this study 1090 patients from age 60 to 76 with small aneurysms of 4–5.5 cm were randomly assigned to undergo elective surgery or to undergo surveillance by ultrasonography.

Results: The mean duration of survival was not significantly different: 6.5 years in the surveillance group versus 6.7 years in the surgical group. The 30-day surgical mortality was 5.5%.

Conclusions: Among patients with small abdominal aneurysms (<5.5 cm), there appears to be no long-term difference in mean survival between early surgery and surveillance groups.

II. THORACIC AORTIC ANEURYSM

Aneurysms of the aorta in the chest are much less common than abdominal aneurysms. They are classified as the ascending, arch, or descending aortic aneurysms. Because of the etiology and natural history, treatment differs for each of these aortic segments. Aneurysms of the descending thoracic aorta are the most common and have similar causes as those of abdominal aneurysms. Aneurysms of the descending aorta usually result from a cystic medial necrosis; the etiology of which remains unknown. Also, cystic medial necrosis is observed in nearly all cases of Marfan syndrome. Another rare connective tissue disorder, Ehlers-Danlos syndrome, may involve the aorta. Syphilis was a common cause of ascending thoracic aneurysms, but is now rare because aggressive antibiotic therapy cures the disease in its early stages. In these cases chest x-ray showed typical linear calcification of the dilated ascending thoracic aorta.

A. Signs and Symptoms

More than 40% of patients are asymptomatic when first diagnosed mainly by routine chest radiography. A large ascending aortic aneurysm may compress the veins that return blood from the head and neck to the heart via the superior vena cava. The aneurysm of the aortic arch or descending aorta may compress the trachea and cause cough, shortness of breath, wheezing, and hemoptysis. Posterior compression of the esophagus may cause difficulty in swallowing and compression of the recurrent laryngeal nerve may produce hoarseness. Pain in the back and chest may occur; this is usually a constant deep, boring pain that can sometimes be severe.

Diagnosis is usually obvious from the chest radiography and aortography. A contrast-enhanced CT scan is accurate in detecting and sizing thoracic aneurysms as well as for monitoring growth. Magnetic resonance imaging (MRI) is also useful.

B. Treatment

I. Medical

Because surgical therapy carries a high mortality rate and is usually not advisable until ascending aneurysms are larger than 5.5–6 cm or larger for descending aneurysms, medical treatment has an important role. A beta-blocking drug is strongly recommended to reduce dP/dt and for the control of blood pressure. Beta-blockers reduce cardiac ejection velocity and hydrodynamic stress. A randomized study of 70 patients with Marfan syndrome treated with propranolol versus no beta-blocker and monitored over a 10-year period showed the following: the treated group showed a significantly lower rate of aortic dilatation, aortic dissection, and aortic regurgitation; fewer deaths; aortic root greater than 6 cm; and significantly lower mortality rates from the 4-year point onward. This study shows that blood pressure must be aggressively controlled.

2. Surgical

Significant risks are associated with thoracic aortic surgery, particularly in the arch and descending aorta and surgery is usually deferred for symptomatic patients or those with aneurysms greater than 6 cm. Aneurysms are usually resected and replaced with a prosthetic sleeve of appropriate size. Postoperative complications include heart attacks, heart failure, stroke, renal failure, respiratory failure, and infection.

skin is cold and clammy with impaired sensorium. Although the blood pressure may remain in the normal range or sometimes be increased, hypotension may occur from external rupture; this is an ominous sign. Syncope usually indicates a rupture into the pericardial sac with cardiac tamponade. A new loud aortic diastolic murmur may be heard and the pulses may be lost in one or more limb.

The majority of patients with aortic dissection are hypertensive and older than 60. Normotensive younger patients usually have associated underlying disease of the aortic root that includes Marfan syndrome. This is a leading cause of aortic dissection in patients under 40. Other causes include giant cell arteritis, lupus erythematosus, Ehlers-Danlos syndrome, Noonan and Turner's syndrome, and relapsing polychondritis. Approximately 15% of patients with coarctation of the aorta die from aortic dissection.

Urgent diagnosis is crucial. A clinical prediction study indicates the following probabilities based on the three most important diagnostic variables: (1) aortic pain with sudden onset, tearing or ripping character, or both; (2) widened mediastinum, aortic widening, or both; and (3) differential pulsations, differential blood pressure, or both. The probability of dissection was high if isolated pulse or blood pressures were found or all three variables were present. Probability was intermediate with isolated findings of aortic pain or mediastinal widening. The probability of dissection was low with absence of all three variables.

III. AORTIC DISSECTION

Ascending aortic aneurysms may undergo internal tearing or dissection resulting in an extremely high mortality of up to 1% per minute and 60% in 60 minutes. Thus, time-consuming investigations that are not sufficiently sensitive or specific, such as CT scans, are usually not recommended. Emergency surgery carries the only hope of survival for patients with dissecting aneurysms, and immediate accurate diagnosis is mandatory to guide therapy.

A. Signs and Symptoms

Sudden onset of severe chest and interscapular pain is common in aortic dissection. The pain is sudden like a gunshot, while heart attack pain builds up gradually over several minutes. The pain is described as a tearing or ripping sensation that becomes rapidly unbearable resulting in a shock-like state. In this state the patient's

B. Diagnostic Testing

I. Transesophageal Echocardiography

Because of its low cost, accuracy, speed, and use at the bedside in very ill patients, further improvement in diagnostic features would likely establish transesophageal echocardiography (TEE) as the investigation of choice, especially in patients who are unstable and in hospitals where MRI is not available. The advantages of TEE include excellent sensitivity and specificity; rapid portability; the ability to be safely performed in critically ill patients including those on ventilators; and the ability to detect and quantify undefined mechanisms of aortic insufficiency, the involvement of coronary orifices, pericardial effusion, and the assessment of left ventricular function. The disadvantages include missing localized dissection of the upper ascending aorta, not defining branch vessel involvement, and the reverberation of artifacts which can be misleading.

2. MRI

MRI proved remarkably useful and safe even in unstable patients with dissection in a blinded study by Nienhaber et al. In centers where new generation magnets are available, MRI may be the primary procedure of choice. New approaches to breath-hold magnetic resonance angiography (MRA) allow rapid acquisition and produce markedly improved images.

3. New Generation CT

Spiral or helical CT scan significantly reduces scanning time, reduces respiration and motion artifact, and allows more images during peak levels of contrast enhancement. Newer scanners can image the entire aorta within seconds displaying three-dimensional images and appearing to have a sensitivity and specificity comparable to that of TEE and MRI.

All three investigative methods, TEE, MRI, and CT, possess potential pitfalls in the evaluation of dissection and are complimentary. Two imaging modalities may be necessary to correctly establish the diagnosis of this life-threatening condition.

C. Management

1. Urgent Medical Management

Urgent medical management of aneurysm must be instituted. This includes immediate reduction in blood pressure to 100–120 mmHg and elimination of pain. The force of left ventricular ejection (dp/dt), or ejection velocity, must also be reduced rapidly with the use of an intravenous beta-blocking drug such as esmolol, metoprolol, or propranolol. These agents are necessary even when the blood pressure is in the low normal range of 90–120 mmHg. If the blood pressure is severely elevated, labetalol, a beta-blocker with vasodilator activity, provides better control of the pressure and reduces dp/dt .

2. Definitive Medical Management

Definitive medical therapy is indicated for uncomplicated, acute distal aortic dissection because survival rate in this group of patients is greater than 90%. It is also indicated for stable, isolated arch dissection because surgery to repair the arch of the aorta is extremely difficult. Medical treatment is also advised for stable, uncomplicated

dissection presenting more than two weeks after onset of symptoms.

3. Surgical Management

Surgical risk is increased by age and the presence of concomitant diseases, particularly respiratory failure caused by severe chronic bronchitis and emphysema. Renal failure, cardiac tamponade, or cardiogenic shock also increases surgical risk. Surgery is the treatment of choice for acute proximal dissection, acute distal dissection complicated by rupture or impending rupture, and dissection in Marfan syndrome.

IV. BERRY ANEURYSM

A different type of aneurysm can occur at the base of the brain. The arteries at this site may have a developmental defect and form small berry-like aneurysms that may remain asymptomatic until a rupture occurs when the individual is between 20 and 50 years old. A subarachnoid hemorrhage at the base of the brain may damage the brain substance and cause coma, death, or severe disability.

These aneurysms may cause sudden intense headaches. Berry aneurysms are not related to high blood pressure, but coexisting hypertension may predispose them to rupture. Patients with coarctation of the aorta or polycystic kidney disease may have coexisting berry aneurysms, and these individuals and family members should be screened with MRI. Fortunately, these aneurysms can be surgically clipped off prior to their rupture. A beta-blocking drug is useful during the perioperative period.

BIBLIOGRAPHY

- Al-Omran, M., Verma, S., Lindsay, T. F., Richard, D., Weisel, Sternbach, Y. et al. Clinical decision making for endovascular repair of abdominal aortic aneurysm. *Circulation*, 110:e517–e523, 2004.
- Brady, A. R., Thompson, S. G., Greenhalgh, R. M. et al. Cardiovascular risk factors and abdominal aortic aneurysm expansion: Only smoking counts. *Br. J. Surg.*, 90:492–3, Abstract, 2003.
- Diethrich, E. B. Stent grafts for the treatment of abdominal aortic aneurysms. *Am. Heart Hosp. J.*, 1:62–8, 2003.
- Ellegala, D. B., Day, A. L. et al. Ruptured cerebral aneurysms. *N. Engl. J. Med.*, 352:121–124, 2005.
- Goldstein, S. A., and Lindsay, Jr., J. Aortic dissection: Non invasive evaluation. *Am. Coll. Cardiol. IACC J. Rev.* May/June 18, 2001.
- Isselbacher, E. M. et al. Thoracic and abdominal aortic aneurysms. *Circulation*, 111:816–828, 2005.
- Lederle, F. A., Wilson, S. E., Johnson, G. R. et al. For the Aneurysm Detection and Management Veterans Affairs Cooperative Study

- Group. Immediate repair compared with surveillance of small abdominal aortic aneurysms. *N. Engl. J. Med.*, 346:1437–44, 2002.
- O’Gara, P. T. et al. Aortic aneurysm. *Circulation*, 107:e43–e45, 2003.
- Parodi, J. C., Palmaz, J. C., and Barone, H. D. Transfemoral intraluminal graft implantation for abdominal aortic aneurysms. *Ann. Vasc. Surg.*, 5:491–9, 1991.
- Powell, J. T., and Greenhalgh, R. M. Small abdominal aortic aneurysms. *N. Engl. J. Med.*, 348:1895–1901, 2003.
- The United Kingdom Small Aneurysm Trial Participants. Long-term outcomes of immediate repair compared with surveillance of small abdominal aortic aneurysms. *N. Engl. J. Med.*, 346:14, 45–52, 2002.
- Upchurch, G. R., and Eagleton, M. J. Endovascular abdominal aortic aneurysm repair. *J. Am. Coll. Cardiol. /ACC J. Rev.* July/August 1994–96, 2002.

Angina

- I. Size of the Problem
- II. Pathophysiology
- III. Diagnosis
- IV. Disease Processes Causing Angina
- V. Stable and Unstable Angina
- VI. Nondrug Treatment
- VII. Drug Treatment
- VIII. Hypertension
- IX. Angina Patients with Heart Failure
- X. Silent Ischemia
- XI. Variant Angina (Prinzmetal's Angina)
- XII. Unstable Angina/Acute Coronary Syndrome

GLOSSARY

afterload arterial impedance, restriction to blood flow delivered from the left ventricle; force against which the myocardium contracts in systole; a major determinant of wall stress.

arrhythmia general term for an irregularity or rapidity of the heartbeat, an abnormal heart rhythm.

atheroma same as atherosclerosis, raised plaques filled with cholesterol, calcium, and other substances on the inner wall of arteries that obstruct the lumen and the flow of blood; the plaque of atheroma hardens the artery, hence the term atherosclerosis (sclerosis = hardening).

ejection fraction the fraction of blood ejected from the heart into the arteries, normally this ranges from 50 to 75%; a low ejection fraction is less than 40%; often used as a marker of left ventricular contractility and function.

electrocardiogram test used to diagnose myocardial infarction; EKG or ECG.

heart failure a failure of the heart to pump sufficient blood from the chambers into the aorta; inadequate supply of blood reaches organs and tissues.

myocardial infarction death of an area of heart muscle due to blockage of coronary artery by blood clot and atheroma; medical term for a heart attack or coronary thrombosis.

myocardium the heart muscle.

palpitation rapid heart rate; the patient feels the heartbeat.

preload the degree of ventricular muscle stretch present at the onset of myocardial contraction; often expressed as end diastolic volume or pressure.

tachycardia increase in heart rate exceeding 100 beats per minute.

PAIN OR DISCOMFORT IN THE CHEST, THROAT, jaw, or arms caused by severe, but temporary, lack of blood and oxygen to a part of the heart muscle defines angina pectoris (see Fig. 1 in the chapter Heart Attacks). Angina is caused by coronary artery disease (CAD) but often referred to as coronary heart disease (CHD). Because obstructive coronary artery disease causes a lack of blood to reach the heart muscle (ischemia), the condition is also called ischemic heart disease (IHD). Angina affects men more commonly than women, and the underlying disease condition is not surprisingly referred to as “the widow-maker.”

I. SIZE OF THE PROBLEM

Angina is caused by CAD. Atherosclerosis of the coronary arteries causes obstruction to blood flow and deprives the heart muscle of blood. Obstructive atherosclerotic CAD leads to stable or unstable angina, fatal or nonfatal myocardial infarction, sudden death, heart failure, arrhythmias, atrial fibrillation, and thromboembolism that may cause stroke. Approximately 15 million Americans have CAD; approximately 7 million have angina and 8 million have had a heart attack. The approximate economic cost of CAD and stroke in North America is approximately \$350 billion, with about \$120 billion just for CAD.

Although there has been a mild decrease in the incidence of CAD in North America during the past decade, the disease process and its complications are expected to increase because of an aging population. Unfortunately, in developing countries the prevalence of CAD and its complications have increased in the past decade, and worldwide it is estimated that by 2025 cardiovascular disease will reach epidemic proportions with approximately 24 million deaths annually worldwide. Table 1

TABLE I
Approximate [Rounded] Population and Incidence of Common Diseases and Death in 2020

	Population (Millions)	Total deaths (Millions)	CMPN	Injury	NonCMPN, non CVD	All CVD	IHD	Stroke	RHD	Other CVD
1990										
World										
% Total deaths	5267	50.4	34.2	10.1	27.4	28.4	12.4	8.7	0.7	6.7
EstME										
% Total deaths	798	7.12	6.4	6.2	42.8	44.6	23.4	11.1	0.3	12.0
EmgME										
% Total deaths	346	3.8	5.6	10.3	29.5	54.6	27.1	16.9	0.7	10.0
DevE										
% Total deaths	4124	39.5	41.9	10.7	24.3	23.0	9.0	7.5	0.7	5.7
2020										
World										
% Total deaths	7844	68.3	15.1	12.3	36.4	36.3	16.3	11.3	0.7	8.1
EstME										
% Total deaths	905	8.6	6.2	5.2	46.3	42.3	22.5	10.6	0.2	9.1
EmgME										
% Total deaths	365	4.8	2.9	8.6	34.8	53.7	27.0	16.3	0.5	9.9
DevE										
% Total deaths	6573	54.8	17.6	13.7	34.9	33.8	14.3	10.9	0.8	12.1

Note: EstMe = established market economies USA, Canada, United Kingdom, Europe, Australia, and New Zealand;

EmgMe = emerging market ec = Russian Federation, Ukraine [highest rates of CVD mortality];

DevE = developing ec = China, India [1.2 billion], Asia, Africa, Latin America, Caribbean;

CVD = cardiovascular disease;

CAD = coronary artery disease;

CPMN = communicable maternal, perinatal, and nutritional.

Modified from. Murray CJL, Lopez AD. *The Global Burden of Disease*, Cambridge MA: Harvard School of Public Health, 1996.

gives the predicted (rounded) world population and incidence of common diseases and mortality rates.

It is relevant that developing countries constitute more than 80% of the world's population and in these regions, particularly in India and other Asian countries, the incidence of CAD is on the rise. The high incidence of communicable, maternal, perinatal, and nutritional diseases in these countries will fall from approximately 41 to 17%, but cardiovascular diseases will increase from approximately 20 to more than 33% over the next 20 years. Japan is unique among the developed countries in that although the stroke rates were the highest in the world during the 1960s, the incidence of stroke did not rise as sharply as in other developed countries and has actually remained lower. In Japan cardiovascular disease rates have fallen more than 60% since the 1960s largely because of a decrease in stroke rates. Life expectancy for men and women are the highest in the world reaching 77 years for men and 83 years for women.

Table 2 shows cardiovascular and CAD mortality rates per 100,000 people in some countries. Note the very low mortality rates in France, Spain, and Italy, and the high rates in Finland, Scotland, Northern Ireland, and the Ukraine.

II. PATHOPHYSIOLOGY

A. Overview

A high blood cholesterol and other factors including a genetic background, cause damage to arteries leading to blockage by atheroma. Obstruction by atheroma occurs most often in the coronary arteries that feed the heart muscle with blood (see Fig. 1 in the chapter Heart Attacks and Fig. 1 in the chapter Atherosclerosis/Atherothrombosis).

The heart muscle is one of the strongest in the body and as powerful as the muscles of the thigh and legs. The act of

TABLE 2

Cardiovascular and Coronary Artery Disease [CAD] Mortality per 100,000 [Rounded]

Country	All causes	CVD	CHD	Stroke
Established Market Economies				
France				
Men	1361	330	142	67
Women	552	122	36	35
Spain				
Men	1323	399	181	93
Women	578	180	52	57
Portugal				
Men	1673	593	207	267
Women	805	305	73	158
Finland				
Men	1691	834	631	110
Women	1718	837	587	132
Scotland				
Men	1846	886	655	139
Women	1103	441	273	107
Economies in Transition				
Russian Federation				
Men	2881	1343	767	409
Women	1223	657	288	178
Ukraine				
Men	2940	1490	749	606
Women	1379	830	342	408

Note: Slovenia has the lowest rates of the former Soviet and Eastern bloc countries: CVD mortality = men 692, women ~300. Italy and Germany have low CVD mortality in men.

walking or running requires contraction of the leg muscles. Such muscle work or activity requires efficient delivery of oxygen, glucose, and other nutrients. These are brought from the heart to the muscles by blood vessels called arteries. The heart, our lifeline, functions as a simple pump that pumps more than 250 million liters of blood in an individual's average lifetime. It is surprising, therefore, that the muscle of this important pump receives a supply of blood via only three small arteries that have a diameter of a soda straw, ranging from 3 to 7 mm. The coronary arteries run along the surface of the heart and are branches of the largest artery in the body, the aorta; the aorta commences at the left ventricle, the main pumping chamber of the heart. In the chapter Anatomy of the Heart and Circulation, Fig. 8 shows the course of the coronary arteries and Figs. 5 and 9 show their origin close to the aortic valve.

If the coronary arteries that feed the heart muscle with blood containing oxygen and nutrients become partially

blocked, the muscle becomes painful when used. The lack of blood to the heart muscle is called myocardial ischemia, and it is typified by characteristic ECG findings of ST-segment depression. (See the ECG in Figure 4.)

As far back as the time of the Caesars, pain in the legs due to obstruction of blood flow in arteries to the legs was labeled as intermittent claudication. The Emperor Claudius limped because of a painful leg, and the word claudication is derived from his name. Similarly, angina occurs because of a reduced blood supply.

B. Atheroma

After age 30 the coronary arteries become slowly obstructed by sludge consisting of cholesterol and smaller blood particles called platelets. The sludge forms a hardness, or plaque, which doctors call atheroma. These plaques bulge into the interior of the arteries, obstructing the free flow of blood (see Fig. 1 and the chapter Atherosclerosis). The word atheroma is derived from the Greek "athere" meaning porridge or gruel. When a plaque of atheroma is cut open, one can see a gelatinous, porridge-like material which contains cholesterol. Fortunately, this porridge-like fatty material does not touch the blood that flows through the artery, because nature covers the fatty material with a protective hard layer of cells called fibrous tissue. A plaque of atheroma therefore consists of a central fatty core, covered by a fibrous cap (Fig. 1).

Fibrous tissue is formed from special cells that are produced everywhere in the body when a repair job is needed; for example, a few days after a large cut or surgical wound is stitched, fibrous tissue cells move in to form a bridge, which transforms over the next few weeks into a scar. Some scars are smooth and some are bumpy and rough. Plaques of atheroma are also sometimes smooth or bumpy and rough. These tough scars in the inner wall of the arteries are perhaps nature's way of patching and healing. Because the vessel wall affected by atheroma gets hardened and the medical word for hardness is sclerosis, the term used for this disease is atherosclerosis.

Plaques of atheroma are most common in the abdominal aorta where it divides to form the vessels to the pelvis and lower limbs, in the coronary arteries, in the carotid arteries to the neck and brain, and in the vessels of the lower limbs.

When atherosclerosis in the coronary arteries causes symptoms, doctors use the term "atherosclerotic heart disease," coronary artery disease, or coronary heart disease (CHD). Many doctors use the term ischemic heart disease because ischemia means a lack of blood and/or oxygen

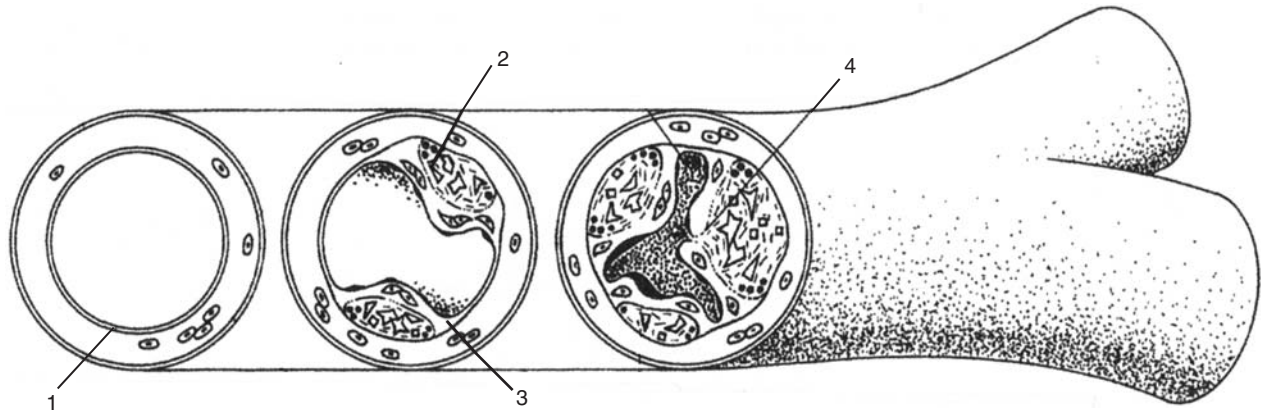

FIGURE 1 Obstruction of the coronary artery by plaques of atheroma that jut into the lumen and deprives the heart muscle of adequate blood supply = myocardial ischemia manifested by chest pain [angina] and reflected on the ECG by characteristic ST segment depression. (1) Smooth lining of vessel; (2) atheroma plaque filled with a variable amount of lipid material, foam cells and other substances [appearance of porridge-like gruel]; (3) a fibrous cap that may be firm and durable prevents rupture, or a thin fragile cap prone to rupture; and (4) rupture of the plaque initiates thrombosis = atherothrombosis. (From Khan, M. G., and Marriott, H. J. L. (1996). *Heart Trouble Encyclopedia*, p. 6, Toronto, Canada: Stoddart Publishing Co.)

caused by poor delivery of blood from arteries to the tissue. Angina, heart attacks, heart failure, and arrhythmias are the main manifestations of CHD.

C. Mechanism of Pain

When a coronary artery is severely obstructed with plaque, the heart muscle still receives an adequate amount of oxygen when the heart is at rest and beating slowly at about 72 beats per minute. During exertion or undue stress, however, the heart rate may increase from 72 to 90 or more beats per minute. A faster heart rate entails more work for the heart, which in turn requires more oxygen to accomplish the work. The obstruction to the artery does not allow sufficient oxygenated blood to reach the heart muscle. During those few moments, the lack of oxygen causes the heart muscle to become painful, and this sensation is perceived by the individual as pain or merely a mild but bothersome discomfort in the chest.

Myocardial ischemia is a dynamic process. Three determinants play a major role in its pathogenesis:

1. Obstruction of a coronary artery by atheroma occludes the artery in a concentric process and is commonly observed in patients with stable angina, but in those with unstable angina the plaques are eccentric
2. Increased myocardial oxygen demand by the vigorously pumping heart muscle
3. A release of catecholamine occurs at the onset of angina and during the episode in most patients with stable angina; release of catecholamine may actually initiate ischemia, which stimulates further catecholamine

release, and the vicious circle perpetuates the lack of oxygen by the myocardium, see Fig. 2

This pathogenesis may manifest as the chest pain of angina. Occasionally myocardial ischemia may occur without causing a sensation of chest pain; this condition is called silent ischemia.

When angina is present in an individual, it is certain that at least one coronary artery will show a greater than 70% obstruction or stenosis if a balloon angiogram is done to visualize the coronary arteries. The obstructive plaque of atheroma is often focal and usually occurs in the proximal portion of the coronary artery and not too distant from the origin of the aorta. Because the lesions are focal and proximal, they are easily reached with the balloon, which dictates the success of angioplasty and bypass surgery. In some individuals and in many diabetics, lesions are multifocal and longer with irregularities that produce a diffuse disease that is more difficult to treat with angioplasty, stents, or bypass surgery. A 25% decrease in the outer radius of a normal coronary artery results in about a 60% decrease in a cross-sectional area. In an artery with 75% stenosis, a 10% decrease in the outer radius would produce a complete occlusion.

During periods of exercise or exertion, catecholamine release causes an increase in heart rate, and an increase in the velocity and force of myocardial contraction produces an elevation in blood pressure and an increase in myocardial oxygen demand. In the presence of significant coronary artery stenosis, an oxygen deficit occurs. Myocardial ischemia increases catecholamine release, resulting in an additional increase in heart rate and blood pressure

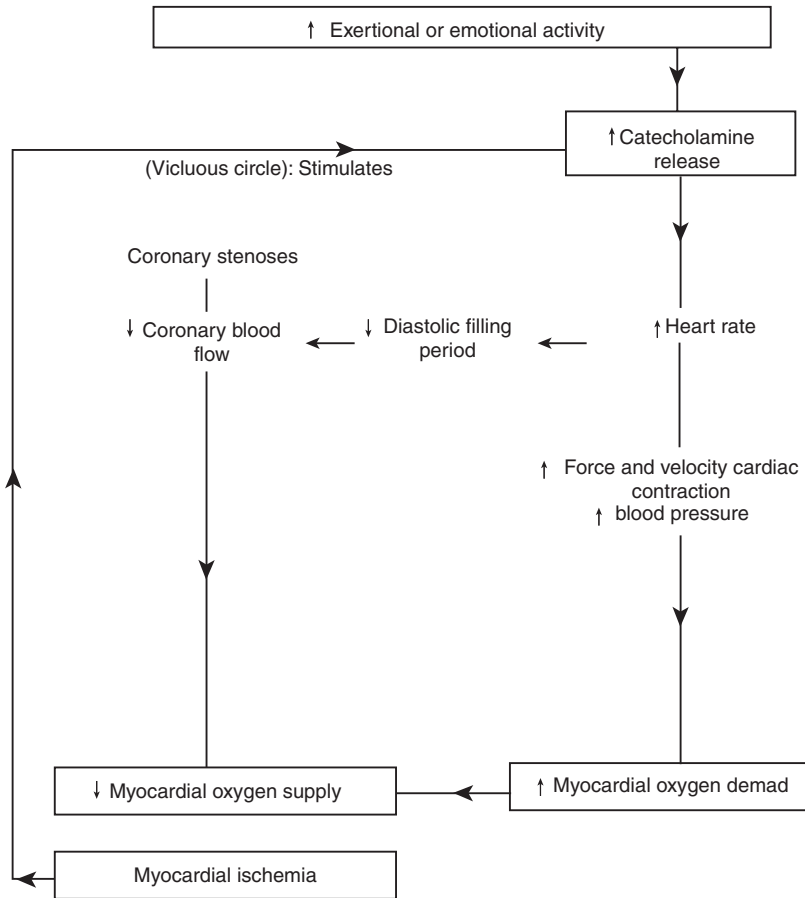

FIGURE 2 Pathophysiology of angina. ↑, increase; ↓, decrease.

with further oxygen lack, and the vicious circle ensues (Fig. 2). In addition the coronary arteries fill during the diastolic period, which is shortened during an increase in heart rate.

Fortunately, no damage happens to the heart muscle during an attack of angina. Full recovery occurs within minutes of the attack. Many patients have several episodes of this fleeting pain or discomfort a few times monthly for over 15 years and learn to cope with the minor restrictions to their lifestyle. In some individuals, angina that is well controlled or stable worsens causing unstable angina that requires special therapy; some patients go on to have heart attacks.

III. DIAGNOSIS

A. Pain Pattern

I. Location

The pain of angina is usually felt in the center of the chest over the breastbone, and only rarely over the breasts (see

Fig. 3 in the chapter Heart Attacks). Pain in the lower jaw accompanied by pain in the chest or arms during a walk or strenuous activity is nearly always due to angina, especially if these symptoms recur during similar activities. Sometimes the discomfort is only in the upper arm with a tingling feeling in the fingers; this pain comes mainly on exertion as opposed to pain produced, for example, by a pinched nerve. A pinched nerve will cause similar discomfort in the arms and fingers when the individual is at rest, but an activity, such as walking, makes little difference.

2. Severity and Character

The pain of angina may be mild to moderate and only occasionally severe. Often it is just discomfort. The individual may even refuse to use the word pain to describe the peculiar sensation that feels like a tightness or a heavy weight on the breastbone. To some it is a burning sensation; to others it is a feeling of strangulation or suffocation that fortunately disappears within one to five

minutes of rest, either with the individual standing or sitting. The pain of angina rarely lasts more than 10 minutes. If an individual has pain similar to that described and lasts more than 15 minutes, the patient should take two or three soft, chewable aspirins (80 mg each) and go immediately to a hospital emergency room.

William Heberden, in 1768 gave a detailed description of a peculiar type of chest discomfort suffered by his patients causing him to adopt the term “angina pectoris.” His description was most appropriate.

There is a disorder of the breasts marked with strong and peculiar symptoms, considerable for the kind of danger belonging to it, and not extremely rare which deserves to be mentioned more at length. The site of it, and the sense of strangling and anxiety with which it is attended, may make it not improperly called angina pectoris.

They who are affected with it are seized while they are walking (more especially if it be uphill, and soon after eating) with a painful and most disagreeable sensation in the breasts, which seems as if it were to extinguish life, if it were to increase or continue; but the moment they stand still, all this uneasiness vanishes.

In all other respects, the patients are, at the beginning of this disorder, perfectly well, and in particular have no shortness of breath, from which it is totally different. The pain is sometimes situated in the upper part, sometimes in the middle, sometimes at the bottom of the breastbone, and often more inclined to the left than to the right. It likewise very frequently extends from the breasts to the middle of the left arm.

Heberden recognized that the pain of angina always got better within a minute or so after the precipitating activity was stopped. For example, the individual might be quite well, but on walking up an incline, especially against the wind, he or she developed discomfort in the chest. If the individual stopped the walk immediately and rested a minute, thus allowing the heart work to decrease, the discomfort disappeared immediately.

This concept of oxygen supply versus its demand by the heart muscle is the hallmark of angina. Make a long list of what precipitates the pain and what relieves it, but the one important clue to help the diagnosis is that the pain or discomfort is precipitated by a particular activity and, once the activity is stopped, the pain disappears within minutes.

B. Activities that Precipitate Angina

These precipitating activities include:

1. Walking up a hill
2. Walking against the wind
3. Running with some associated anxiety for a bus or to a place, especially while carrying a bag; anxiety is made more profound if the individual is late and must rush, thus, there is exertion and emotional stress
4. A brisk walk or similar exertion soon after eating; this does not include bending and stooping, which can precipitate indigestion
5. Unaccustomed exertion
6. Emotional distress; for example, bad news, a scare, anger, rage, nightmares, etc.
7. Pain may occur during overwhelming excitement; for example, watching your team playing football, hockey, baseball, basketball, and similar exciting programs

Most important, relief of pain in an individual with stable angina always occurs within minutes of cessation of the precipitating exertional or emotional activity. Relief with nitroglycerin occurs promptly within one to two minutes.

IV. DISEASE PROCESSES CAUSING ANGINA

Atherosclerosis Atheroma is the main cause of obstruction of coronary arteries and accounts for more than 90% of cases of angina and coronary artery disease.

Coronary artery spasm (variant angina) — This is a rare cause of angina in which spasm of the coronary artery occurs often without identifiable stimuli. This condition, also called Prinzmetal’s variant angina, is more common in the Mediterranean and Italian population. In some patients, exposure to cold, smoking, emotional stress, aspirin ingestion, or cocaine use may trigger coronary spasm. The coronary spasm is usually relieved by nitroglycerin, nitrates, and calcium antagonists, and discontinuation of these medications may cause worsening of spasm. Beta-blocking drugs may increase coronary artery spasm. The clinical hallmarks of coronary artery spasm include pain usually occurring at rest, often during sleep and described as chronic angina at rest, an ECG during pain showing elevation of the ST segment which is normalized by the use of nitroglycerin. The ST segment returns to normal on cessation of pain caused by coronary spasm.

Anomalous coronary artery — This rare occurrence may go undetected, see the chapter Congenital Heart Disease.

Aortic stenosis — Obstruction of blood flow from the left ventricle through the aortic valve into the aorta may be impeded by a tight stenotic valve. This severe obstruction to blood flow imposes a severe workload on the left ventricular myocardium that requires a greater demand for oxygen. If the coronary arteries are mildly affected by atheromatous obstruction, then angina occurs much earlier than expected. Angina occurring in patients with severe aortic stenosis carries a poor prognosis and requires surgical intervention.

Hypertrophic cardiomyopathy — The thickened and severely hypertrophied left ventricular myocardium requires more oxygen and the supply may be outstripped by the demand (see the chapter Cardiomyopathy).

Severe anemia — In patients with moderate atheromatous obstructive disease severe anemia or loss of blood can further deprive the myocardium of blood and oxygen; this can precipitate angina or myocardial infarction.

Kawasaki disease — In this rare disease of childhood coronary artery aneurysms occur and chest pain caused by angina may be bothersome (see the chapter Kawasaki Heart Disease).

Giant cell arteritis — This rare diseases of the walls of the artery, in particular the temporal artery, may affect the coronary arteries. This process is called a vasculitis.

Chemotherapeutic agents — The chemotherapeutic agent 5-fluorouracil is known to cause coronary artery spasm in some patients that may lead to symptoms of angina and occasionally myocardial infarction (see the chapter Chemotherapy-Induced Heart Disease).

Syndrome X — This rare syndrome appears to affect mainly women, and in these patients angina-like symptoms may occur in the presence of normal coronary arteries. There is no evidence of obstruction or spasm in these patients, and the exact cause for pain remains obscure.

V. STABLE AND UNSTABLE ANGINA

There are two types of angina: stable and unstable. Angina is described as stable if the condition has been present for more than two months, or if there has been no change in the pattern of pain, particularly no change in the frequency of attacks, severity, or duration of pain. Patients with stable angina only get pain at rest with sudden emotional stress. Angina is described as unstable when angina is present for

less than 60 days, or when there is an increase in the frequency, severity, and duration of pain and a change in the known precipitating factors. If pain that normally occurs only on exertion or moderate activities starts to occur on minimal activity or at rest but without emotional stress, a patient should seek urgent attention in the emergency room.

A. Case History

A 54-year-old man was late for a job interview. With some difficulty, he found a parking space. It was a very cold and windy January day, and he walked quickly for about two hundred yards toward the building. Suddenly, he felt a strange sensation in his chest. He kept on walking, but about a minute later the discomfort felt like a heavy weight on his breastbone. His chest felt tight as he reached the building, and he rested against the wall. He took a few deep breaths and felt better after about one minute. He had his job interview without any further discomfort and remained pain-free until a few months later when, while walking up an incline, he felt a similar pain. Again he had to stop for a minute or two to get relief from the strange feeling of suffocation or strangulation that accompanied the tight feeling in his upper chest. The next day he was able to walk about a mile at a normal pace on a level grade without chest discomfort. A few days later he went golfing. During the first nine holes he felt well and had no chest discomfort, but walking upslope on the long 11 hole, he felt pressure in his chest, a tightness across the shoulder, and a heaviness in his arms. He stopped pulling his golf cart and stood still for a minute. Somewhat embarrassed for holding up the game, he searched his golf bag for some antacid tablets but, as he opened the package, he noticed the pain had completely gone. He felt well that night. The next day when he walked quickly the discomfort returned. His wife insisted on a visit to the doctor. The doctor found him to be slightly overweight with a normal ECG reading. He was given nitroglycerin to be used under the tongue and an oral nitrate called isosorbide dinitrate in tablet form to help dilate the coronary arteries and relieve pain.

During the next three months, the man suffered from severe headaches that lasted a couple of hours after taking his medication. His chest discomfort did not get worse, but his wife insisted on a referral to a cardiologist. The cardiologist confirmed the diagnosis of stable angina and recommended that the man follow a weight-reducing, low-cholesterol, low-saturated fat diet and that he stop smoking. The cardiologist discontinued the oral nitrate

drug and replaced it with timolol, a beta-blocking drug, which produced further relief of chest pain during the next year.

B. Tests Required to Confirm Diagnosis

1. Resting ECG

The resting ECG may be normal in patients with angina, but during pain an ECG virtually always shows abnormalities. The ECG is the test most frequently used to diagnose angina, and it is the only test that can confirm the early diagnosis of a myocardial infarction. The ECG shows positive abnormalities hours before damage to the heart muscle is revealed by the tests for cardiac enzymes (troponins and CK-MB). In individuals with suspected CHD, a baseline ECG that is normal or shows mild abnormalities can be used for comparison with future ECGs. A normal ECG is shown in Fig. 3. During myocardial ischemia (angina), a diagnostic ECG finding shows a greater than 0.05-mm depression of the ST segment (see Fig. 4).

2. Exercise Stress Test

A treadmill exercise test using the Bruce protocol is used worldwide to detect myocardial ischemia that is precipitated by exercise. The ECG tracing during exercise-induced ischemia shows typical features that can be easily recognized. Although the test is of little value in screening asymptomatic patients who are at low risk for CAD, it is most useful for patients who are symptomatic. False-positive tests are not uncommon in women.

3. Cardiac Nuclear Scans

Cardiac nuclear scans performed following treadmill exercise or during myocardial-induced ischemia provoked by dipyridamole, adenosine, or dobutamine are particularly useful. These tests are not sufficiently sensitive or specific, however, and further technologic advances are necessary. Despite the use of these scans for more than 30 years, further sophistication is necessary. There is room here for further research and development particularly because these tests are widely used and are often inaccurate.

4. Coronary Angiograms

For some patients, coronary arteriography may be required. Arteriography is the gold standard for detecting obstruction of coronary arteries by atheroma. The exact site and location of the obstruction can be identified for interventional therapy with balloon angioplasty, stent implantation, or bypass surgery. For a further description of tests, see the chapter Tests for Heart Diseases.

VI. NONDRUG TREATMENT

A. Weight Reduction Effects

If you have angina and you lose 10–25 lb, you will certainly experience less pain, you will require a smaller dose of antianginal medication, and you may not require angioplasty or surgery.

Weight reduction, relief of stress, a low-saturated fat diet, and avoidance of smoking are the most important nondrug treatments for patients with angina. Weight loss depends on eating less calories and burning off more

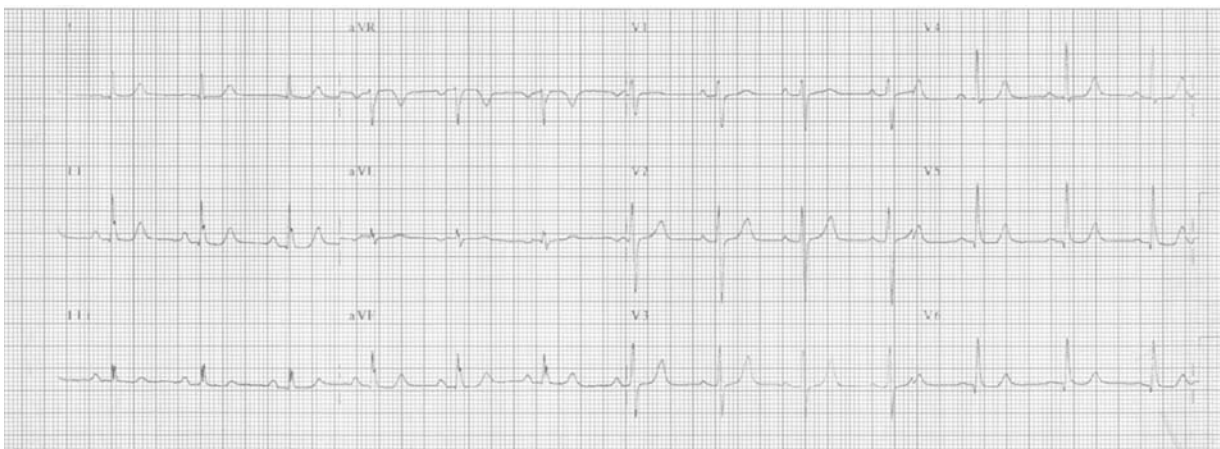

FIGURE 3 Normal ECG.

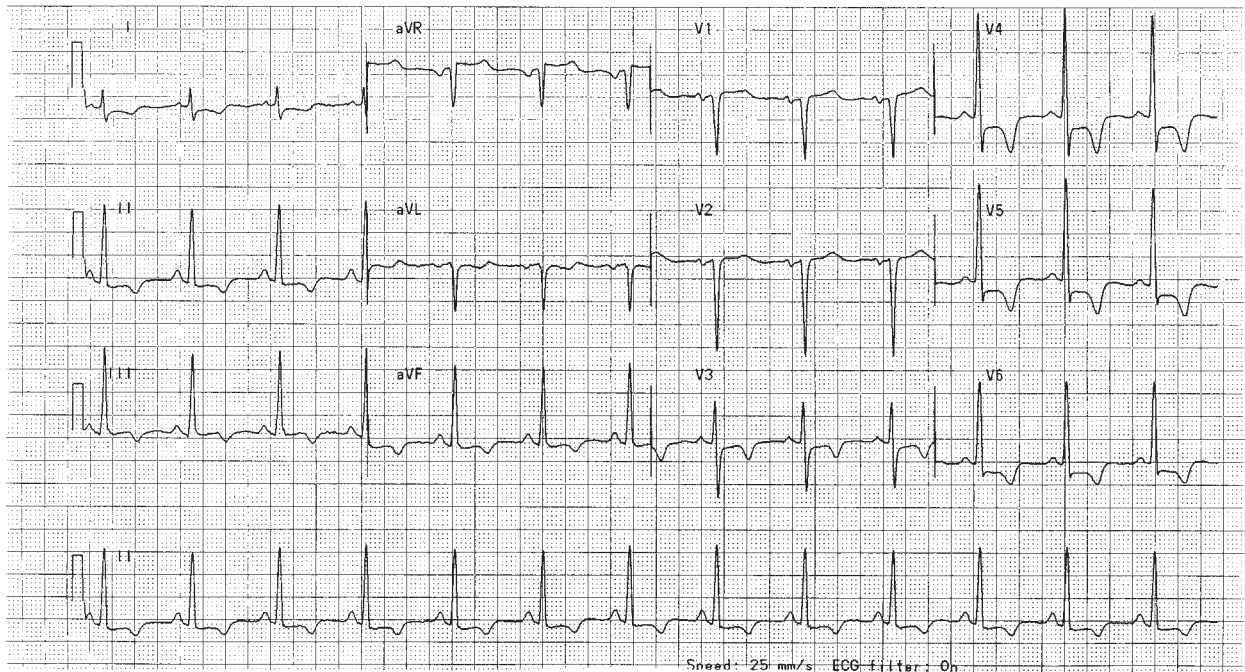
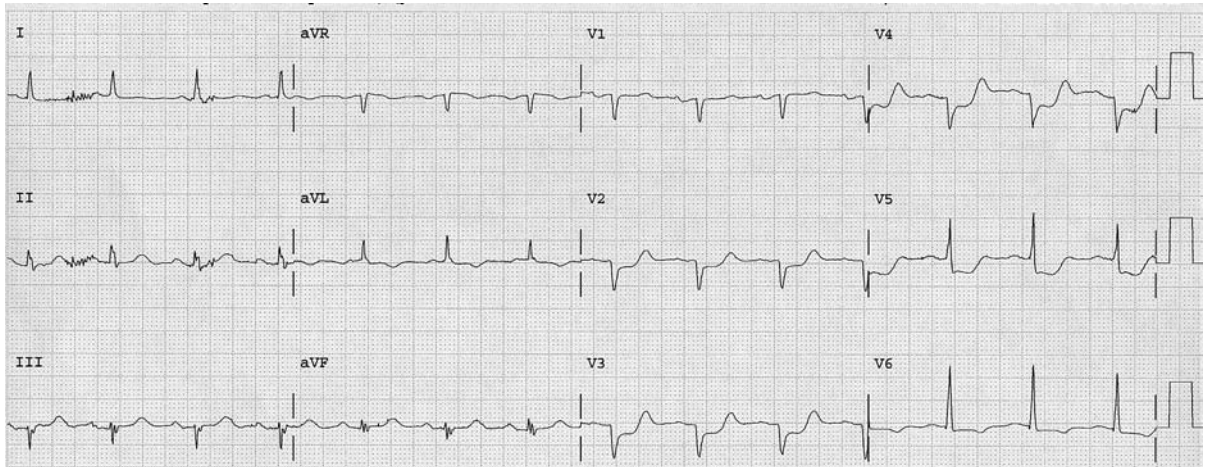

FIGURE 4 A. Abnormal ECG. B. Marked ST depressions and wave inversion anterior myocardial and left ventricular.

calories during exercise. A combination of a low-calorie diet with some form of exercise program that increases caloric expenditure must be followed, otherwise the weight gain that often occurs after stopping a low-calorie diet will ensue. All diets that are proven to cause weight loss over a period of years depend on reduced intake of calories. Calories do count, do not let anyone tell you otherwise.

Weight loss occurs with reduction of calorie intake to less than 1000 calories daily and exercise to burn off more calories. A meal should contain a moderate amount of

protein, but a low-saturated fat content. Reduce your intake of high-calorie foods containing refined sugars or starches. A greater than 75% decrease in the usual consumption of all products derived from wheat flour, potatoes, and rice along with 40 minutes of exercise daily is guaranteed to cause significant weight loss.

Fish three times weekly, even canned tuna, salmon, sardines, and herring, will help to reduce the saturated fat in the diet. Many individuals may stick to these rules, but forget that alcohol, both mixes and beer, are high in calories. Avoid fast foods because they often high in

calories and salt. An increase in salt increases the work of the heart muscle and puts a strain on the heart, which can lead to heart failure and shortness of breath. Thus, patients with high blood pressure, heart failure, and angina are advised to follow a low-salt diet.

Lack of motivation often results in a failure to reduce weight. It is a tough battle for most overweight individuals to fight on their own, and success is more often obtained by joining a weight-loss program or clinic. We strongly advise you to consult your physician or to contact your Heart and Stroke Association for recommended publications on weight loss. The Mediterranean style diet is cardioprotective and strongly recommended, see chapters Diets and Heart Disease and Dyslipidemia.

B. Exercise

What about exercise and angina? An exercise stress test using a treadmill or bicycle under the supervision of a physician should provide the answer to the question: "How much exercise is safe for me?" Usually, a safe level of exercise is that which will bring on only mild discomfort or mild shortness of breath. You should slow down for a few seconds then stop for a minute or so before continuing the activity (such as a quarter- or half-mile walk). Stretching exercises and walking — including climbing two or three flights of stairs daily — will improve your muscle tone. Exercise alone, however, cannot remove the obstruction caused by plaques in arteries. Patients with angina do not jog because this activity often precipitates pain. For more information, see the chapter Exercise and the Heart.

C. Smoking

Nonsmoking men are 10 times less likely to have a fatal or nonfatal heart attack than heavy smokers. Sudden death by heart attack is more common in heavy smokers than in nonsmokers. Drugs that are effective in preventing angina and death lose their effectiveness in smokers because the by-products of cigarettes interfere with the breakdown of the drugs in the liver. These drugs include the frequently used beta-blocker propranolol and calcium antagonists such as nifedipine. Also, bypass grafts become blocked within a few years of bypass surgery in patients who continue to smoke. If you have angina and chronic bronchitis, cigarette smoking will cause an increase in shortness of breath.

Women between the ages of 35 and 50 who have functioning ovaries rarely suffer from angina or have heart attacks. Women who smoke and have an elevated blood

cholesterol level, unfortunately, increase their risk of having a heart attack and angina prior to age 50.

Perhaps, rather than quitting, changing to a different brand of cigarettes is considered. The bad news is that filter cigarettes and low-nicotine or low-tar brands of cigarettes do not decrease the risk of heart attacks. In fact, filter cigarettes deliver more carbon monoxide to the smoker's system and cause more heart attacks than plain cigarettes.

The oxygen supply to the heart muscle is low in patients with angina. Angina patients who are smokers experience pain at lower levels of exercise. Nicotine causes a slight increase in the heart rate and a rise in blood pressure; therefore, the heart muscle demands more oxygen. Carbon monoxide delivered from cigarettes steals oxygen away from the heart muscle, which is already deprived of oxygen. So the combination of carbon monoxide and nicotine is bad news. Regardless of the present condition of your heart, do yourself a favor and quit smoking.

Still, how do you stop smoking? It is easier said than done. The first step is motivation. Consider the facts. The dangers of carbon monoxide are well known. You wouldn't stand around inhaling exhaust fumes from a car, especially if its engine was running in an enclosed garage; you know that that situation would cause death. Yet, we have information today that proves heavy cigarette smokers are exposed to eight times the level of carbon monoxide considered safe in industry, and it has been proven that heavy cigarette smoking is a cause of heart attacks and sudden death.

The addiction to nicotine is so powerful that nothing will help if the smoker is not motivated to quit. Even bronchitic patients continue to smoke because the addiction to nicotine is so great. To help you to quit smoking, enlist the assistance of stop smoking clinics; even hypnosis is a viable alternative. The American Cancer Society and the National Cancer Institute provide several types of programs to help smokers quit. Local cancer societies usually provide a list of programs that can help. Consult a physician for advice on nicotine tablets, patch, gum, or nasal spray. Most smokers who cannot motivate themselves. Get help now!

D. L-Arginine

Arginine increases nitric oxide availability in the arterial wall and this causes vasodilation and increases blood flow. Some clinical trials indicate modest improvement in angina symptoms with its use, but they are not consistent. Arginine is found in many foods and an arginine food bar is also available.

VII. DRUG TREATMENT

In patients with stable angina treatment with drugs usually produces about a 75% improvement in symptoms and quality of life. Three groups of drugs are usually employed: nitrates, beta-blockers, and calcium blockers (calcium antagonists). Aspirin is added to prevent coronary thrombosis which causes heart attacks.

A. Nitrates

Angina sufferers are advised by their doctor to always carry nitroglycerin, even if the requirement is only two pills a year. Nitroglycerin is a nitrate that is used under the tongue or in tablet or spray form. The tablets should be kept in a dark bottle and not in a pill box, because opening the box lets in light, which will destroy the effectiveness of the drug within a few weeks. Remove the cotton wool from the bottle so the pills can be easily reached when in a hurry. Leave the cotton wool in a stock bottle kept in the refrigerator; these tablets will maintain their strength for more than one year. Tablets in a bottle that is opened often should be good for three months.

I. Mechanism of Action

Nitroglycerin dilates the veins, especially those in the lower half of the body. Blood stays in these enlarged veins and less blood reaches the heart. The heart then has less blood to pump and the muscle works less, thus requiring less oxygen, and, as a result, the pain is relieved. The mechanism of action of nitrates and nitrate tolerance is illustrated in Fig. 5.

Nitroglycerin tablets will work best if the lower half of the body is kept much lower than the head, that is, it is better to sit than to lie flat after taking them. You may remain propped up in bed. Nitroglycerin causes expansion or dilatation of the blood vessels in the scalp, and this effect may produce a headache. The headache is not due to an increase in blood pressure; in fact, nitroglycerin dilates the arteries slightly and this causes a small fall in blood pressure. Therefore, be careful not to take more than two doses of nitroglycerin and not to walk right away. Unless you are accustomed to the dosage, you may become dizzy or feel faint and fall.

Nitrate tablets that are swallowed are the oldest preparations available in the treatment of angina. These drugs are low in cost and have no serious side effects. They cause frequent headaches, however, and are less effective than beta-blockers.

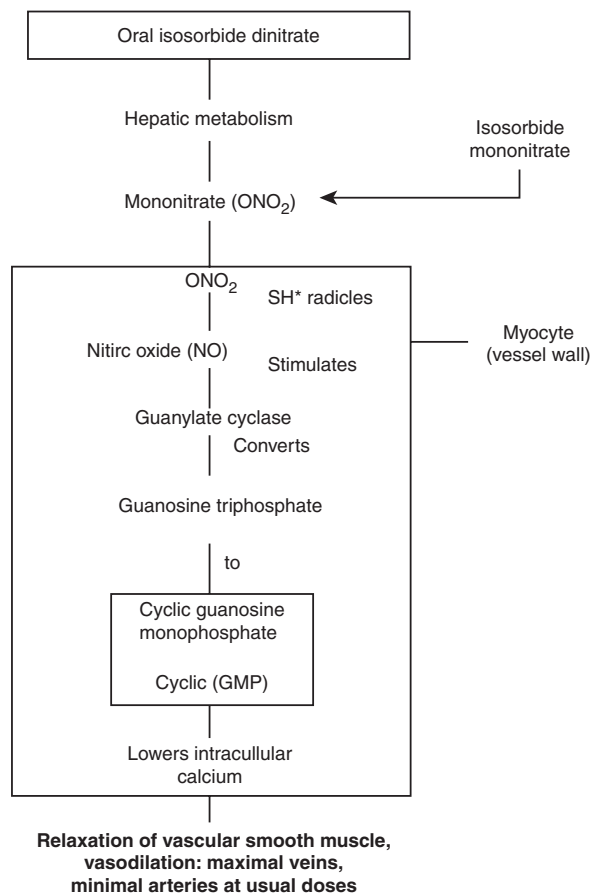

FIGURE 5 Nitrates' mechanism of action. * SH, sulfhydryl radicles required for formation of NO, oxidized by excess exposure to nitrates become depleted. Leading to nitrate tolerance.

a. Nitroglycerin—Glyceryl Trinitrate

Supplied: Sublingual nitroglycerin tablets: 0.15 mg, 0.3 mg, and 0.6 mg. Sublingual glyceryl trinitrate tablets: 300 µg, 500 µg, and 600 µg. Also available as Nitrolingual spray.

Dosage: Patients are usually advised to start with 0.3 mg. The tablet is placed under the tongue with the patient seated. The drug will not be as effective if the patient is lying down, and if the patient is standing, dizziness or faintness may occur. Thereafter, the usual prescribed dose is 0.3 mg or 0.6 mg of nitroglycerin or 500–600 mg of glyceryl trinitrate.

b. Cutaneous Nitroglycerins (Patches)

Supplied: Comes as paste or ointment, which must not be massaged into the skin. Slow-release cutaneous preparations in the form of adhesive patches are clean and dry and

TABLE 3
Nitrates

Generic sublingual	Trade name or available as ^a	Supplied and dosage ^b
Nitroglycerin	Nitroglycerin	0.15, 0.3, 0.4, 0.6 mg (USA)
	Nitrostat	0.3, 0.6 mg (C) ^c
	Nitrostablin	600 µg (C)
	Nitrolingual spray	Metered dose of 0.4 mg
Glyceryl trinitrate (UK)	Glyceryl trinitrate GTN	300, 500, 600 µg
	Coro-nitro spray	400 µg/metered dose
	Nitrolingual spray oral	400 µg/metered dose
Nitroglycerin oral tablets	Nitrong SR	2.6 mg (USA, C)
	Nitrostat SR, Nitrobid	7 AM, 2 PM
Buccal tablets	Nitrogard (USA)	1, 2, 3 mg
	Susadrin (USA)	1, 2, 3 mg
	Nitrogard SR (C)	1, 2, 3 mg
	Suscard (UK)	1, 2, 3, 5 mg
Isosorbide dinitrate oral, tablets	Isosorbide dinitrate	10, 20, 30, 40 mg (USA)
		10, 20, 30 mg (UK)
		10, 30 mg (C)
	Isordil	10, 20, 30, 40 mg (USA)
		10, 30 mg (UK)
		10, 30 mg (C)
		10, 20 mg (UK)
	Cedocard 10, Cedocard 20, Cedocard Retard	20 mg
		40 mg capsules
		10, 20 mg (USA, UK)
Isordil Tembids		40 mg capsules
Sorbitrate		10, 20 mg (USA, UK)
Isosorbide mononitrate	Isosorbide mononitrate	20 mg
	Elantan 20	20 mg
	Elantan 40	40 mg
	Ismo	20 mg b. i. d., 7 h apart
	Imdur	60–120 mg once daily

^aSeveral other trade names available.

^bFor dosage see text.

^cC, Canada.

can be used once daily. The paste or ointment starts to work in 30–60 minutes and lasts from 4 to a maximum of 6 hours. The long-acting adhesive patches last from 16 to 20 hours and must be removed every 12 h. The skin preparations should not be applied to the forearms, hands, or lower legs, because it takes longer for the drug to reach the general circulation. These preparations are useful during dental work and for minor or major surgery in patients with CHD.

Dosage: Skin preparations should be used only for 2–14 days. These drugs are not meant to be used for more than a few weeks except if other drug therapy or surgical intervention is inappropriate. They are less active if used for more than 12 h daily because of nitrate tolerance. In

addition, these preparations must not be stopped suddenly; for example, after using them for a few weeks, the dose should be tapered and reduced slowly over the next one to two days. In some patients, when the drugs are stopped suddenly, angina can become worse. These preparations are applied for 12 h and taken off for 12 h. Various nitrate preparations are listed in Table 3.

c. Isosorbide Dinitrate (*Isordil*)

Supplied: Sublingual tablets to be dissolved under the tongue: 5 mg. Tablets for oral use: 10 mg, 20 mg, and 30 mg. Prolonged-action tablets: 40 mg. Prolonged-action capsules: 40 mg.

Dosage: A sublingual 5-mg tablet is dissolved under the tongue before an activity known to produce chest discomfort. The 10-mg tablet is swallowed three times daily on an empty stomach, for example, one hour before meals. If headaches are not too severe, the drug can be increased to 15 mg three times daily for a few days or weeks, then 30 mg three times daily. The prolonged-action 40 mg preparation is taken once or twice daily. Nitrates are more effective taken at 7 a.m., 12 p.m., and 5 p.m. The 12-h gap without nitrates prevents the body from developing tolerance, which destroys the drug's effectiveness.

Advice and adverse effects: The sublingual 5-mg tablets take three to five minutes to become effective, somewhat longer than nitroglycerin; therefore, patients are advised to use nitroglycerin during an attack of angina. The drug's effect lasts from 20 to 60 minutes. Nitrates cause headaches and dizziness. They should not be used as first choice in the treatment of angina pectoris, especially since beta-blockers have proven to be effective and reliable. In addition, beta-blockers can prevent death or favorably alter the outcome of a heart attack. The use of oral nitrates, therefore, makes sense in patients who cannot take or do not respond to beta-blockers.

d. Isosorbide Mononitrate (Imdur)

Supplied: The 5-mononitrate of isosorbide dinitrate has become available.

Dosage: It is to be taken 20 mg after meals at 7 a.m. and 2 p.m. daily.

Maintenance: 20–40 mg twice daily. Imdur can be taken 60–120 mg once daily at 7 a.m.

B. Beta-Blockers

I. Actions

Beta-blockers are a group of drugs that reduce the action of adrenaline (epinephrine) on the heart and arteries. Beta-blockers decrease the heart rate so the pulse falls from a resting level of about 72 beats per minute to a range of 50–60 beats per minute. Second, they reduce blood pressure and third, they cause the heart muscle to contract less forcefully. All three effects cause the heart muscle to require less oxygen, thus preventing angina.

Beta-blockers block the effects of the stimulant stress hormones adrenaline and noradrenaline at the so-called beta-receptor sites present on the surface of cells in the heart and in arterial blood vessels. They therefore prevent the increase in heart rate, the force of heart muscle contraction, and the rise in blood pressure normally produced by these stimulants.

Beta-blockers are recommended as a first-line oral drug treatment in the management of angina pectoris. Table 4 emphasizes the rationale for the use of beta-blocking drugs as first-line agents versus that of calcium antagonists and oral nitrates.

In patients with angina, at least one coronary artery has a block greater than 75%. At rest, sufficient blood reaches the heart muscle; however, during moderate activities, the heart rate and blood pressure increase and the heart muscle contracts more forcefully to do the work because more

TABLE 4
Beta-Blocker: First-Line Oral Drug Treatment in Angina Pectoris

Effect on	Beta-blocker	Calcium antagonist	Oral nitrate
Heart rate	↓	↑↓	↑
Diastolic filling of coronary arteries	↑	—	—
Blood pressure	↓↓	↓↓	—
Rate pressure product	↓	— ^a	—
Relief of angina	Yes	Yes	Variable
Blood flow (subendocardial ischemic area) ^b	↑	↓	Variable
First-line treatment for angina pectoris	Yes	No	No
Prevention of recurrent ventricular fibrillation	Proven	No	No
Prevention of cardiac death	Proven	No	No
Prevention of pain from coronary artery spasm	No	Yes	Variable
Prevention of death in patient with coronary artery spasm	No	No	No

^aRPP variable decrease on exercise, but not significant at rest or on maximal exercise

^bDistal to organic obstruction

Note: ↓, decrease; ↑, increase; —, no significant change.

From Khan, M. Gabriel. *Cardiac Drug Therapy*, sixth edition, Philadelphia, W. B. Saunders, 2003.

blood containing oxygen is required. The blockage prevents an adequate supply of oxygen from reaching the muscle. This oxygen lack causes the heart muscle to become painful, and the heart rate and blood pressure may further increase during the stress of pain. Basically, beta-blockers cause the heart muscle to require less oxygen to do the same amount of work. The heart rate multiplied by the systolic blood pressure gives an estimation of the amount of work and oxygen required by the heart muscle. Beta-blockers decrease both heart rate and blood pressure, therefore, less oxygen is required. They also cause the heart muscle to contract less forcefully so that less oxygen is used. These drugs divert blood from the areas of the heart that have an abundant supply to the deprived area.

2. Indications and Goals

If there are no contraindications to the use of beta-blockers, the treatment of angina should be sublingual nitroglycerin and aspirin plus a beta-blocker preferably given once and, at most, twice daily. Randomized controlled clinical trials have demonstrated that beta-blocker therapy is efficacious in reducing symptoms of angina and episodes of ischemia and in improving exercise capacity.

The beta-blocker is always started at a very low dose and, over a period of days or weeks, increased to an effective dose. A low dose of propranolol, for example, 20 mg three times daily before meals increasing after a week or two to 40 mg three times daily, is advisable. The doctor will check to be sure that the pulse and blood pressure are stable and that there are no side effects from the medications. If necessary, the dose can be increased to 160 mg long-acting (LA) capsule once daily, or 160 mg in the morning and 80 mg at bedtime. Atenolol is given 50 mg once daily. The target pulse rate is 55–60 beats per minute at rest and less than 100 beats per minute on moderate activities that normally push the heart rate to greater than 120 beats per minute.

Some patients, 1 in 100, are very sensitive to beta-blockers and their pulse rate decreases to less than 48 beats per minute. It is extremely rare to learn of patients who come to harm because of a slow heart rate. A heart rate of less than 42 beats per minute may cause dizziness, and the individual may be forced to lie down. The body quickly compensates and the effects of a 40-mg tablet wear off in about four hours. The doctor usually reduces the dose, or in very few cases, the drug is discontinued. In North America there are more than 12 million individuals who are taking beta-blockers for management of their CAD. Many patients are, however, deprived of

such therapy because of inappropriate concerns regarding the adverse effects of beta-blockers (see the chapter Beta-blockers).

3. General Cautions

The list below outlines some general cautions regarding beta-blockers.

1. Do not suddenly stop taking beta-blockers. Beta-blockers control the heart rate and oxygen requirement in just the same way as the reins that control a horse. If beta-blockers are stopped abruptly, it is similar to cutting the reins; the horse may gallop away. Therefore, the heart rate may increase from the accustomed 55–65 beats per minute to 80–90 beats per minute. It is relatively safe to miss one dose of a beta-blocker, or at the most two doses per week. It is unadvisable to miss any doses, but there are always unavoidable circumstances. No harm usually results from one missed dose; however, omitting the drug for two to three days consecutively may precipitate angina. Withdrawal should be gradual over weeks and under the guidance of your doctor.
2. Report shortness of breath or wheezing to your doctor as soon as possible.
3. Beta-blockers must not be used in combination with monoamine oxidase (MAO) inhibitors, which are drugs used to treat different types of severe depression.
4. Do not take decongestants or cold or cough remedies containing epinephrine (adrenaline), phenylephrine, or phenylpropanolamine. These drugs can cause an increase in blood pressure.
5. The combination of beta-blockers and digitalis (digoxin) is safe.
6. Metoprolol and propranolol are broken down in the liver more rapidly in smokers so that blood levels of the drugs are reduced; thus, the drugs may be rendered useless. Atenolol and nadolol are not broken down in the liver and are not affected by smoking. Timolol has been shown to prevent heart attacks or death in smokers as well as nonsmokers.
7. Two pints of beer or 3 oz of liquor does not cause any interaction or alteration in effectiveness.

4. Contraindications

Do not take beta-blockers if you have any of the following problems.

1. Severe heart failure: Few patients with angina have heart failure. Beta-blockers can precipitate heart failure in

patients with very weak heart muscle function. It must be pointed out that the heart muscle is the strongest muscle in the body; it does more work than any other muscle during an individual's lifetime. Many patients who have had two heart attacks are still able to engage in a brisk two-mile walk or climb three flights of stairs, and some can jog one to three miles. The remaining heart muscle is stronger than the quadriceps muscle of the thigh. The heart muscle is strong enough in about 90 out of 100 patients with angina to allow the use of beta-blockers. Patients with mild or moderate degrees of heart failure have benefited by the use of beta-blocking drugs. Beta-blockers are indicated for mild-to-moderate heart failure, because a randomized clinical trial has shown that they prevent mortality and hospitalization in this category of patients. See the chapter entitled "Heart Failure."

2. Bronchial asthma, severe chronic bronchitis, or emphysema: Some patients with mild chronic bronchitis and for whom beta-blockers are deemed necessary to control angina can use atenolol, bisoprolol, or metoprolol, which has less effect on the lungs than nonselective beta-blockers. These three drugs are relatively safe at low doses.
3. Allergic rhinitis: Do not commence beta-blockers during a flare-up of allergic rhinitis.

5. Side Effects

a. The Heart and Vessels

- There can be precipitation of heart failure in patients with a very weak heart muscle, as discussed above.
- Severe slowing of the heart rate to less than 42 beats per minute in rare cases if the dose is not carefully adjusted; this is usually quickly spotted by the symptoms of dizziness and ill feeling, and can be quickly rectified; hence, in practice this is not a problem.
- Extremely cold hands and feet can occur in about 10% of patients; the condition improves immediately on discontinuation of the beta-blocker.

b. The Lungs

- There can be precipitation of wheezing and difficult breathing in individuals who are known to have allergic asthma or severe bronchitis.

c. The Nervous or Muscular System

- Dizziness due to excessive slowing of the pulse and reduction in blood pressure
- Vivid dreams in about 10% of patients taking propranolol; these usually clear up when given an alternative medication such as atenolol, timolol, or nadolol
- Mild depression occurring in less than 10% of patients, it is not a major problem in practice; because atenolol and nadolol do not get into the brain like propranolol, they cause fewer problems
- Weakness and muscle fatigue of varying degree, occurring in about 10% of patients; a change from propranolol to metoprolol, atenolol, or nadolol is advisable; if symptoms persist and no other cause can be found, beta-blockers should be discontinued
- Reduction of libido and impotence that occurs in less than 5% of patients, it must be monitored by patient and physician; however, beta-blockers, by decreasing the heart rate, blood pressure, and heart work can be useful if pain is precipitated by intercourse

d. Other Side Effects

- In some patients insomnia, altered sleep patterns, nervousness, muscle cramps, and muscle joint pains can be caused by pindolol

6. Individual Beta-Blockers

Beta-blockers are the most beneficial drugs used in the treatment of angina. They have been in use in the UK since 1964 and in the United States since 1969. The first and most well-known drug in this group is propranolol (Inderal). Several other beta-blockers have also been approved by the FDA. Commonly used beta-blockers include acebutolol, atenolol, bisoprolol, carvedilol, nadolol, metoprolol, propranolol, and timolol.

a. Atenolol (Tenormin)

Supplied: Tablets: 25 mg (U. S.), 50 mg, and 100 mg.

Dosage: Start 25 mg daily for about three days, then one 50-mg tablet daily at any time of the day. If the condition warrants, the doctor often starts with 50 mg daily. Food does not interfere with the effectiveness of atenolol. If angina is not controlled and especially if the blood pressure is elevated 100 mg may be necessary. This

beta blocker is not as effective as the lipophilic beta blockers carvedilol, bisoprolol, or metoprolol.

b. Carvedilol (Coreg)

Supplied: Tablets: 3.25 mg, 6 mg, 12 mg, and 25 mg.

Dosage: 3.25 mg trial dose then twice daily increasing over weeks to 25 mg twice daily. See the chapter entitled "Beta-Blockers."

c. Bisoprolol (Zebeta, Monacor)

Supplied: Tablets: 5 mg and 10 mg.

Dosage: 5–10 mg once daily. This drug is a selective beta-blocker that spares the beta-blocking effect on the lungs. This salutary effect is more powerful than that of atenolol and metoprolol.

d. Metoprolol (Lopressor, Betaloc, Toprol XL)

Supplied: Tablets: 50 mg and 100 mg.

Dosage: 50 mg twice daily, before breakfast and at bedtime, increasing if necessary to 100 mg twice daily in the majority of cases, and in a few cases to 200 mg twice daily. This drug has advantages over propranolol in patients with mild chronic bronchitis; if beta-blockers are deemed necessary to control angina, metoprolol up to 100 mg twice daily is safer than an equivalent dose of propranolol. Toprol XL has the advantage because it is effective when taken once daily. It also has a low side effect profile

e. Nadolol (Corgard)

Supplied: Tablets: 40 mg, 80 mg, 120 mg, and 160 mg.

Dosage: 40–160 mg only once daily. As with atenolol, food makes no difference to absorption, and smoking does not alter effectiveness. After a few days or weeks at 40 mg daily, the drug may be increased to 80 mg and in some patients to 160 mg daily.

f. Propranolol (Inderal)

Supplied: Tablets: 10 mg, 20 mg, 40 mg, and 80 mg.

Dosage: 20 mg three times daily before meals, increasing slowly, under a doctor's supervision, to 120 mg daily. After several weeks, an LA capsule of 80 mg or 160 mg of propranolol may be preferable. Most patients with angina should receive 160–240 mg before adding a

calcium antagonist or an oral nitrate. As emphasized, smoking destroys the effectiveness of propranolol.

C. Calcium Blockers (Antagonists)

Normally, the muscle in the walls of arteries contracts under the influence of the movement of calcium into the cells. Calcium blockers prevent calcium from moving into the cell, thereby causing relaxation and dilatation of the arteries throughout the body. Calcium blockers are not as effective as beta-blockers. The use of calcium blockers in combination with beta-blockers can improve the lifestyle of patients with angina (see the chapter Calcium Antagonists).

1. Action

The muscle in the heart and walls of arteries contracts under the influence of a movement of calcium into the cells. Calcium is transported from the exterior to the interior of cells through a system of tubules called slow calcium channels. Calcium reaches the interior of muscle cells and interacts with specialized proteins in the muscle, which then contract. Calcium blockers block the slow calcium channels; this action prevents calcium from going into the cells, thereby causing the muscle of the heart and arteries to relax. These drugs are also known as calcium channel blockers, calcium entry blockers, slow channel blockers, or calcium antagonists (see the chapter Calcium Antagonists).

2. Indications

In variant angina (coronary artery spasm), all available calcium antagonists — amlodipine, nifedipine, verapamil, and diltiazem — are equally effective in this rare condition. In stable angina pectoris calcium blockers should be used in the following situations: if beta-blockers are contraindicated and if the response to adequate doses of beta-blockers is good but not completely effective.

3. Individual Calcium Blockers

a. Amlodipine (Norvasc)

Supplied: Tablets: 5 mg and 10 mg.

Dosage: 5–10 mg once daily.

Actions, advice, and adverse effects: Amlodipine strongly blocks the slow calcium channels and causes dilatation of arteries. This drug, therefore, dilates the

coronary arteries and the arteries of the limbs and elsewhere. This action causes a reduction in the resistance in the arteries, blood pressure, and the work of the heart. By causing less work for the heart, along with dilatation of the coronary arteries, the pain of angina is relieved. Amlodipine has no effect on the electrical system of the heart, and it is safe in patients with electrical disturbances. There are no absolute contraindications to its use. Dizziness occurs in 3–7% of patients. If dizziness occurs, the drug is reduced. Dizziness can be made worse when nifedipine is combined with oral nitrates or nitrate preparations placed on the skin or drugs that lower blood pressure. Edema of the legs occurs in about 5% of patients, but this does not indicate heart failure; instead it is due to dilatation of capillaries in the legs. Headaches and a throbbing sensation in the head occur in 5–10% of patients, and occasionally the drug has to be discontinued. Patients should be reassured that the throbbing is not due to an increase in blood pressure but to dilation of the arteries in the scalp. The action is similar to a tablet of nitroglycerin put under the tongue. The headaches or throbbing become less severe after a few weeks of treatment, and the majority of patients can tolerate amlodipine at 5 mg daily. Mild flushing and burning in the scalp and head and occasional indigestion do occur.

b. Verapamil (Isoptin)

Supplied: Tablets: sustained release 120 mg, 180 mg, and 240 mg.

Dosage: 120–240 mg once daily.

Indications: Verapamil can be used in variant angina (coronary artery spasm), which is rare. When chronic stable angina pectoris does not respond to beta-blockers, verapamil is an effective alternative. During severe palpitations (paroxysmal atrial tachycardia) verapamil given intravenously in the emergency room is very effective and restores the heart rhythm to normal.

Actions, advice, and adverse effects: Verapamil is a moderately potent vasodilator. It causes a decrease in the contraction of heart muscle; an action which can produce heart failure. Side effects include constipation, which may be distressing, especially in the elderly. In women, secretion of milk from the breasts (galactorrhea) and a minor degree of liver disturbance may rarely occur. Verapamil is contraindicated in patients with a very slow pulse rate, heart block, sick sinus syndrome, heart failure, an enlarged heart, or poor heart muscle function.

Drug Interactions: The combination of beta-blockers and verapamil may cause marked reduction of the pulse rate to less than 42 beats per minute. Also, heart failure can

be precipitated. Interacting with digoxin, verapamil can increase the level of digoxin in the blood, and when both drugs are used, the physician has to recheck levels of digoxin more frequently and may need to lower the dose of both drugs. Amiodarone is a drug that is used for the treatment of serious forms of extra beats (ventricular tachycardia) and should not be combined with verapamil. When combined with tranquilizers, verapamil may have a sedative effect. Verapamil also increases the effects of anticoagulants (blood thinners).

c. Diltiazem (Cardizem, Tiazac)

Supplied: Controlled release (CD): 80 mg, 120 mg, 240 mg, and 300 mg.

Dosage: Diltiazem CD (Cardizem CD): 120 mg, 180 mg, or 240 mg once daily. Maximum: 300 mg.

Indications: These are the same as those listed for verapamil except that the drug is not used in the treatment of paroxysmal tachycardia because its effect is very mild.

Actions, advice, and adverse effects: Diltiazem has a similar action to verapamil but is not as powerful. This drug may cause headaches and dizziness. Disorientation and occasional, reversible elevation of liver enzymes (transaminases) have been seen in some patients. Constipation may be bothersome, although this is much less than observed with verapamil. The combination with beta-blocking drugs is much safer than the combination with verapamil, but a few patients may develop slow heart rates requiring the discontinuation or lowering of the dose.

D. Aspirin

Aspirin is the mainstay of antithrombotic therapy in patients with CAD.

I. A Life-Saving Therapy

Angina leads to fatal or nonfatal myocardial infarction in many patients. During onset of the chest pain that heralds a myocardial infarction, thrombosis is occurring in the coronary artery. This thrombus can be partly prevented and infarction or death can be averted in more than 20% of individuals by the use of a quick-acting aspirin formulation such as chewable aspirin. Thus, two to four, 80-mg chewable aspirins are recommended to individuals who sustain chest pain believed to be due to a heart attack. It is important to emphasize that the emergency use of chewable aspirin can save morbidity and mortality from a

heart attack but that nitroglycerin in spray or tablet form does not prevent fatal or nonfatal infarctions. The use of chewable aspirin is more important than the use of nitroglycerin and worldwide education about this is essential.

2. Preventive Therapy

An enteric-coated aspirin tablet is given to virtually all patients with angina or CAD in an effort to prevent fatal or nonfatal infarction. A timely Veterans Administration study utilizing 324 mg of aspirin in patients with unstable angina resulted in a 50% reduction in mortality rate and nonfatal myocardial infarctions. In another randomized study, aspirin was shown to reduce the cardiac mortality rate by 50% in patients with unstable angina. A Swedish study using 75 mg of aspirin in patients with stable angina showed a 34% reduction in infarctions and death. In patients who are allergic or intolerant to the use of aspirin, clopidogrel bisulfate (Plavix) is recommended.

E. Statins

Statins are well-known cholesterol-lowering agents that have proved, in randomized controlled trials, to prevent serious cardiac events in patients with CAD. Fatal and nonfatal infarctions are prevented in patients with stable or unstable angina.

Available statins include atorvastatin, fluvastatin, pravastatin, simvastatin, and the recently introduced more powerful statin, rosuvastatin. Statins are recommended for all patients with stable or unstable angina to maintain low-density lipid (LDL) cholesterol levels at less than 80 mg/dl (2.0 mmol/L), see the section under Dyslipidemia.

F. Anti-Inflammatory Agents

Atheromatous plaque, whatever the causative factor, is exceedingly inflammatory in unstable angina, and reactivation of the process and plaque rupture may trigger new thrombus formation. There is minor evidence but unproven role for *Helicobacter pylori*, *Chlamydia pneumoniae* and *C. pneumoniae*. Particularly high titers of antibodies have been observed in patients with unstable angina as well as the presence of elementary bodies, DNA, and antigens in the atherosclerotic arterial wall.

Gupta et al. screened 220 men after myocardial infarction. Eighty patients with antibody titers greater than 1:64 were randomized to azithromycin or placebo for

3 or 6 days. During the study the odds of an event in patients with placebo were four times higher than those in nonrandomized patients with negative titers or in treated patients with a positive titer.

In the study of 200 patients with unstable angina and non-Q-wave myocardial infarction, treatment with roxithromycin administered for 30 days reduced the 6-month mortality rate from heart attack from 4 to 0%, and the rate of death, infarction, or recurrent ischemia from 9 to 2%. Nonetheless, these are small studies and other clinical studies have been unsuccessful. Antibiotic therapy awaits the results of large randomized controlled trials.

Aspirin's salutary effect is caused by its antithrombotic properties, but its anti-inflammatory action appears to provide some beneficial effects. In addition the use of statins has been shown to reduce levels of C-reactive protein and inflammatory response in atheromatous plaques. This beneficial effect of statins appears to be independent from a lowering of LDL cholesterol.

G. Newer Agents: Nicorandil

Nicorandil is a nicotinamide ester with a dual mechanism of action. Its distinctive pharmacologic effect is to open ATP-sensitive potassium channels, thus dilating peripheral and coronary resistance arterioles. In addition it has a unique feature — the drug possesses a nitrate moiety which dilates systemic veins and epicardial coronary arteries. This drug, therefore, increases coronary blood flow which reduces pre- and afterload. Nicorandil has been shown to have antianginal efficacy and a safety profile similar to that of oral nitrates and beta-blockers. Additionally, it appears that the drug has cardioprotective properties. These effects are probably caused by the drug's ability to mimic the powerful ischemic preconditioning phenomenon by opening ATP-sensitive potassium channels.

A randomized clinical trial in 5126 patients showed significant improvement in outcome due to a reduction in major coronary events caused by Nicorandil in patients with stable angina. Mean follow up was 1.6 year.

H. Ranolazine

Ranolazine is an investigation treatment for angina. The drug is not Beta blocker, calcium antagonists or nitrate. Clarke et al. indicate that the drug appears to shift adenosine triphosphate production away from fatty acid oxidation in favor of more oxygen efficient carbohydrate oxidation. In a small clinical trial in patients with chronic angina the drug at a dose 500–1000 mg twice daily was

well-tolerated and increased exercise performance without significant decrease in blood pressure or increase in heart rate. The drug did not alter survival in the one year follow up. The 1500-mg, twice daily dosing caused dizziness and nausea, ischemia, and constipation and rarely syncope. The drug should not be used in patients administered other agents that increase the QT interval.

VIII. HYPERTENSION

Hypertension causes atheroma formation and atherosclerosis. A significant number of patients with angina have hypertension: blood pressure greater than 140 or pressures in the high normal range of 135–140 systolic mmHg. Hypertension causes an increased thickness of the left ventricular muscle, which requires more blood and oxygen to function. Hypertension must be aggressively controlled. The best antihypertensive agents for patients with angina are beta-blockers and ACE inhibitors. ACE inhibitors are particularly useful because they dilate the arterial circulation and rest the myocardium without stimulating the heart to beat at a faster rate or to require more oxygen. Other vasodilators that include α_1 -adrenergic blockers, such as terazosin, increase heart rate and ejection velocity and are contraindicated in patients with CAD. These agents may increase the incidence of heart failure. A randomized clinical trial the HOPE study; see the Bibliography indicates that ACE inhibitors improve survival in patients with CAD.

IX. ANGINA PATIENTS WITH HEART FAILURE

Coronary artery disease leads to myocardial infarction which causes weakness of the heart muscle, and some patients over time develop heart failure. These patients are difficult to treat because they are not candidates for bypass surgery. Medical therapy must be used judiciously. Nitrates, in particular cutaneous nitrates, applied 14 h daily, plus a small dose of a beta-blocking drug along with an ACE inhibitor and a diuretic, are beneficial for many patients. Beta-blockers should be avoided in patients with severe heart failure, but those with mild-to-moderate heart failure gain major relief. Recent randomized clinical trials have shown the beta-blockers, carvedilol, metoprolol, and bisoprolol effective in reducing mortality rates and hospitalization.

In patients with an ejection fraction less than 35%, digoxin is indicated. Calcium antagonists should be avoided. Verapamil and diltiazem are contraindicated

because of reduced cardiac contractility and the possibility of precipitating heart failure. Other calcium antagonists including amlodipine and nifedipine should be avoided because they may precipitate heart failure.

X. SILENT ISCHEMIA

Myocardial ischemia without pain or symptoms is common in patients with CAD. The incidence of silent ischemia is high and the outcome unfavorable in patients with unstable angina. Interventional therapy is often recommended. Holter monitoring after noncardiac surgery in patients with stable angina and post myocardial infarction patients has documented a high incidence of silent ischemia within the second to fourth day after surgery.

In the Total Ischemic Burden Bisoprolol Study, both bisoprolol and nifedipine reduced the number and duration of transient ischemic episodes. Bisoprolol was significantly more effective than nifedipine and reduced the morning peak of ischemic activity. This is in keeping with other studies, which indicate that beta-blocking drugs are superior to calcium antagonists in producing salutary effects in patients with silent ischemia, especially in reducing early morning ischemia that may relate to the peak incidence of early morning heart attacks and death.

Patients with evidence of silent ischemia are recommended to be treated with a beta-blocking drug, aspirin, and a statin and investigated with exercise stress testing. Those who show strongly positive exercise tests and/or ejection fractions less than 45% should be submitted to coronary angiography for consideration of an appropriate revascularization procedure.

XI. VARIANT ANGINA (PRINZMETAL'S ANGINA)

Prinzmetal's variant angina is caused by coronary artery spasm of undetermined etiology. Pain usually occurs at rest as opposed to typical stable angina occurring during exertion. The ECG during pain shows ST-segment elevation as opposed to typical angina showing ST-segment depression. An ECG is not necessary, however, to initiate therapy.

Beta-blockers can increase coronary artery spasm and cause chest pain so they are contraindicated in these patients. Management includes cessation of smoking, avoidance of aspirin that may cause spasm, and the use of high doses of nitroglycerin and calcium antagonists.

Unfortunately patients with variant angina, even when the syndrome is completely controlled by calcium antagonists, have died or have had myocardial infarctions. Although calcium antagonists are efficient in controlling the pain of coronary artery spasm, they do not prevent death. Coronary artery bypass surgery is indicated in patients with significant atheromatous coronary artery obstruction, which occurs coincidentally in some patients with variant angina.

XII. UNSTABLE ANGINA/ACUTE CORONARY SYNDROME

A. Pathophysiology and Symptoms

The pathophysiology of unstable angina has been identified. In the majority of cases, disease-causing plaques are asymmetric with irregular borders and a narrow neck. Platelets then aggregate on the surface of plaques forming small thrombi. Lipid-rich plaques have a predilection for rupture, and rupture of the plaque with an overlying thrombus is a common finding on angiography. Silent ischemia is fatal and observed in patients with unstable angina. Prognosis appears to be worse in this subset of patients.

Unstable angina patients represent a heterogeneous group. Patients usually present with chest pain at rest lasting from about 10 to 40 minutes; pain usually lasts more than 20 minutes but less than hour. Patients with stable angina with chest pain only on exertion who develop pain with much lower levels of activities or pain at rest are a subset of unstable angina. Patients with new onset angina occurring within the past 30 days have high-risk unstable angina.

B. Management

All patients with unstable angina should proceed to an emergency room and be administered 160 mg of chewable aspirin immediately if they have not already taken the drug.

1. Risk Stratification and New Classification

During the past 50 years the three major complications of CAD associated with chest pain were classified as myocardial infarction, severe chest pain without elevated cardiac enzymes classified as unstable angina, and chest pain mainly on exertion labeled as chronic, stable angina. For more information, see the chapter Heart Attacks.

Since 1998 national cardiac societies have altered this classification as follows:

1. Patients with chest pain who have the characteristics of a heart attack associated with typical ECG change demonstrating ST-segment elevation are labeled as an ST-segment elevation myocardial infarction (see the chapter Heart Attacks).
2. Patients with chest pain and the characteristics of a heart attack associated with ECG changes demonstrating ST-segment depression accompanied by elevated troponin or CK-MB enzyme elevations are labeled as non-ST elevation myocardial infarction (formerly called non-Q-wave myocardial infarction).

Cardiac societies in the United States, Canada, and the UK have introduced a new terminology: acute coronary syndrome in an attempt to identify high risk patients with acute chest pain. Classification of ischemic pain, acute coronary syndrome includes:

1. Subset of patients with ST-segment elevation myocardial infarction
2. Patients with non-ST elevation infarction (old term: non-Q-wave MI)
3. Patients with typical features of unstable angina with elevated troponin levels are reclassified as non-ST elevation infarction
4. Patients with unstable angina: abnormal ECG changes with normal troponin levels
5. Patients with unstable angina, normal ECG changes, and normal troponins are classified as low risk

Patients are stratified into low- or high-risk categories based on:

1. ECG changes done during pain showing ST-segment depression indicating ischemic changes; ST-segment depression greater than 0.05 mm (0.05 mV) indicates high risk.
2. Patients with abnormal ECG and elevated troponins are at high risk for serious events; elevated troponin levels indicate necrosis of myocardial cells or a small myocardial infarct.
3. Patients with evidence of recent onset of rest pain that is recurrent, accompanied by ECG changes, are high risk.
4. Patients without rest pain and absence of ECG changes with normal troponin levels are at low risk.
5. Diabetics with any of the above features are considered high risk as are those patients who have had a previous infarction.
6. An elevated C-reactive protein is considered to be evidence of increased risk (see the chapter C-Reactive Protein and the Heart).

2. Drug Management

Drug management is an important aspect of treating unstable angina/acute coronary syndrome.

1. All patients are admitted to a coronary care unit or to an area where telemetry and blood pressure monitoring are available.
2. Intravenous nitroglycerin is given to virtually all patients to relieve chest pain.
3. Morphine in small doses is given to stop pain that can stimulate autonomic responses that may increase cardiac arrhythmias and myocardial necrosis.
4. A beta-blocking drug is begun provided there is no contraindication such as asthma or bradycardia less than 50 beats per minute present.
5. Chewable aspirin is usually administered in the emergency room followed by enteric-coated aspirin 325 mg once daily.
6. If a beta-blocking drug is contraindicated, a calcium antagonist such as diltiazem is administered.
7. Heparin is given subcutaneously; low molecular weight heparin has been shown to be equally as effective as intravenous heparin and easier to monitor.
8. A statin is commenced to maintain LDL-cholesterol levels less than 2.0 mmol/L (80 mg/dl).
9. Powerful antiplatelet agents are commenced, especially in high-risk patients. Clopidogrel followed by catheterization and coronary angiography are used to define the lesion.
10. Glycoprotein IIb/IIIa receptor blockers such as abciximab (ReoPro), Integrilin, or tirofiban are administered to high-risk patients undergoing coronary angiography and/or angioplasty with or without stent placement; several studies suggest that mainly diabetics with acute coronary syndrome benefit from such therapy. Abciximab has been shown to have beneficial effects in randomized clinical trials in acute coronary syndrome patients undergoing angioplasty or stenting (see the chapter Antiplatelet Agents).

3. Interventional Therapy

Interventional therapy such as coronary angioplasty with or without stenting or bypass surgery should be strongly considered in patients with high-risk unstable angina/acute coronary syndrome. These patients usually undergo coronary angiography within 24 h on admission to an emergency room.

Coronary angiograms define the obstructive lesions, and balloon angioplasty and stent placement are done in the

majority of patients. Balloon angioplasty with stenting has transformed the management of unstable angina/acute coronary syndrome (see the chapters Angioplasty and Stents).

In most categories of patients and in virtually all diabetics, interventional therapy has advantages over medical therapy for amelioration of angina, a return to normal lifestyle, and probable prolongation of life. Coronary artery bypass surgery is indicated if angioplasty or stenting are not possible, particularly in patients with an ejection fraction of less than 45%, and in diabetics.

When coronary artery bypass surgery is selected, patients who can receive an internal mammary artery graft are most fortunate. The arterial graft has a prolonged patency of 15–20 years versus approximately 10–12 years for saphenous vein grafts. Khot et al. have recently shown that radial artery bypass grafts have an increased occurrence of angiographically severe stenosis and occlusion compared with left internal mammary artery grafts and saphenous vein grafts (see the chapter Coronary Artery Bypass Surgery).

BIBLIOGRAPHY

- Cannon, C., and Braunwald, E. Unstable angina. In *Heart Disease*, sixth edition. E. Braunwald, D.P. Zipes, and P. Libby, eds. W.B. Saunders, Philadelphia, 1232–71, 2201.
- Chaitman, B.R., Skettino, S.L., Parker, J.O. et al. Anti ischemic effects and long-term survival during ranolazine monotherapy in patients with chronic severe angina. *J. Am. Coll. Cardiol.*, 43:1375–1382, 2004.
- Clarke, B., Wyatt, K.M., McCormack, J.G. et al. Ranolazine increases active pyruvate dehydrogenase in perfused rat hearts: Evidence for an indirect mechanism. *J. Mol. Cell. Cardiol.*, 28:341–350, 1996.
- Goldman, S., Zadina, K., Moritz, T. et al. Long-term patency of saphenous vein and left internal mammary artery grafts after coronary artery bypass surgery. *J. Am. Coll. Cardiol.*, 44:2149–2156, 2004.
- Gupta, S., Leatham, E.W., Carrington, D. et al. Elevated *Chlamydia pneumoniae* antibodies, cardiovascular events, and Zithromycin in male survivors of myocardial infarction. *Circulation*, 96:404, 1997.
- HOPE Investigators: Yusuf, S., Sleight, P., Pogue, J. et al. Effects of an angiotensin converting enzyme inhibitor, ramipril, on death from cardiovascular causes, myocardial infarction, and stroke in high-risk patients. The Heart Outcomes Prevention Evaluation Investigators. *N. Engl. J. Med.*, 342:145–153 2000,
- The IONA Study Group. Effect of the nicorandil on coronary events in patients with stable angina: The impact of the nicorandil in angina (IONA) randomized trial. *Lancet*, 359:1269–75, 2002.
- Khan, M. Gabriel. Angina. In *Cardiac Drug Therapy*, sixth edition, WB Saunders, Philadelphia, 2003.
- Khan, M. Gabriel. Unstable angina. In *On Call Cardiology*, second edition, WB Saunders, Philadelphia, 187–206, 2002.
- Kim, M.C., Annapoorna, K., and Sharma, S.K. Refractory angina pectoris: Mechanisms and therapeutic options. *J. Am. Coll. Cardiol.*, 39:923–34, 2202.

- Khot, U. N., Friedman, D. T., and Pettersson, G. Radial artery bypass grafts have an increased occurrence of angiographically severe stenosis and occlusion compared with left internal mammary arteries and saphenous vein grafts. *Circulation*, 109:2086–2090, 2004.
- Kramer, C. M. et al. The comprehensive approach to ischemic heart disease by cardiovascular magnetic resonance imaging. *J. Am. Coll. Cardiol.*, 44: 2182–2184, 2004.
- Lewis, H. D., Davis, J. W., Archibald, D. G. et al. Protective effects of aspirin against acute myocardial infarction and death in men with unstable angina. Results of a Veterans Administration Corporative Study. *N. Engl. J. Med.*, 309:396, 1983.
- Moreno, P. R., Fuster, V. et al. The year in atherothrombosis. *J. Am. Coll. Cardiol.*, 44: 2099–2110, 2004.
- Nissen, S. E., Tuzcu, E. M., Schoenhagen, P. et al. For the reversal of atherosclerosis with aggressive lipid lowering (REVERSAL) investigators statin therapy, LDL cholesterol, C-reactive protein, and coronary artery disease. *N. Engl. J. Med.*, 352:29–38, 2005.
- Park, S. J., Kim, Y. H., Lee, B. K. et al. Sirolimus-eluting stent implantation for unprotected left main coronary artery stenosis. *J. Am. Coll. Cardiol.*, 45:351–356, 2005.
- Petersen, S., Peto, V., Rayner, M. et al. Coronary heart disease statistics. London: British Heart Foundation, 2004.
- Raff, G. L., Gallagher, M. J., O'Neill, W. W., et al. Diagnostic accuracy of noninvasive coronary angiography using 64-slice spiral computed tomography. *J. Am. Coll. Cardiol.*, 46: 552–557, 2005.
- Ridker, P. M., Cannon, C. P., Morrow, D. et al. For the pravastatin or atorvastatin evaluation and infection therapy-thrombolysis in myocardial infarction 22 (PROVE IT-TIMI 22) investigator: C-reactive protein levels and outcomes after statin therapy. *N. Eng. J. Med.*, 352:20–28, 2005.
- Rodriguez, A. E., Baldi, J., Carlos Pereira, F., et al. The ERACI II investigators five-year follow-up of the Argentine randomized trial of coronary angioplasty with stenting versus coronary bypass surgery in patients with multiple vessel disease (ERACI II). *J. Am. Coll. Cardiol.*, 46: 582588, 2005.
- Serruys, P. W., Ong, A. T. L., van Herwerden, Lex, A., et al. Five-year outcomes after coronary stenting versus bypass surgery for the treatment of multivessel disease: The final analysis of the arterial revascularization therapies study (ARTS) randomized trial. *J. Am. Coll. Cardiol.*, 46: 575-581, 2005.
- Steinhubl, S. R., Berger, P. B., Mann, J. T., III et al. For the CREDO Investigators. Early and sustained dual oral antiplatelet therapy following percutaneous coronary intervention: A randomized controlled trial. *JAMA*, 2411–20, 2002.
- Sousa, J. E., Costa, M. A., Tuzcu, E. M., et al. New frontiers in interventional cardiology. *Circulation*, 111:671–681, 2005.

Angioplasty/Coronary Balloon

- I. Procedure
- II. Indications
- III. Contraindications and Limitations
- IV. Outcome of Angioplasty

GLOSSARY

angina pectoris short duration, recurrent chest pain or pressure often accompanied by feelings of suffocation and impending doom; most frequently associated with lack of blood and oxygen to the heart muscle.

atheroma same as atherosclerosis, raised plaques filled with cholesterol, calcium, and other substances on the inner wall of arteries that obstruct the lumen and the flow of blood; the plaque of atheroma hardens the artery, hence the term atherosclerosis (sclerosis = hardening).

ejection fraction the fraction of blood ejected from the heart into the arteries, normally this ranges from 60 to 75%; a low ejection fraction is less than 40%; often used as a marker of left ventricular contractility.

ischemia temporary lack of blood and oxygen to an area of cells, for example, the heart muscle, usually due to severe obstruction of the artery supplying blood to this area of cells.

myocardial infarction death of an area of heart muscle caused by blockage of a coronary artery by blood clot and atheroma; medical term for a heart attack or coronary thrombosis.

myocardium the heart muscle.

THE FIRST SUCCESSFUL CORONARY ANGIOPLASTY was performed by the late Dr. Andreas Gruntzig in Zurich, Switzerland, in 1977. Dr. Gruntzig pioneered the modern era of interventional cardiology with his innovative percutaneous transluminal coronary angioplasty (PTCA). Using a double-lumen balloon catheter, he performed the first PTCA by dilating the proximal left anterior descending coronary artery and unblocking an atheromatous obstruction of a 37-year-old man with angina. Repeat angiograms on the 10th anniversary of this procedure showed continued vessel patency; the patient has remained symptom-free for more than 20 years.

I. PROCEDURE

PTCA, percutaneous transluminal coronary angioplasty, is so named because the instrument is passed through the skin (percutaneously) and then through the lumen of the artery (transluminal) into the coronary artery, which is molded into shape (angioplasty). The balloon-tipped catheter is positioned next to the plaque of atheroma in the artery (see Figure 1 in chapter entitled “Angina.”). The balloon is inflated for 30–60 seconds and then widened by pressure (see Fig. 1). The narrowed artery becomes dilated due to splitting (dissection) of the plaque and overstretching of the middle wall (media) of the artery. Transient chest pain may occur during the inflation but is quickly relieved. Several inflations may be necessary to accomplish dilation of the artery. The balloon is then deflated, and dye is injected so that the cardiologist can see if adequate dilation and flow of blood has been achieved. An optimal angiographic result (less than 20% residual

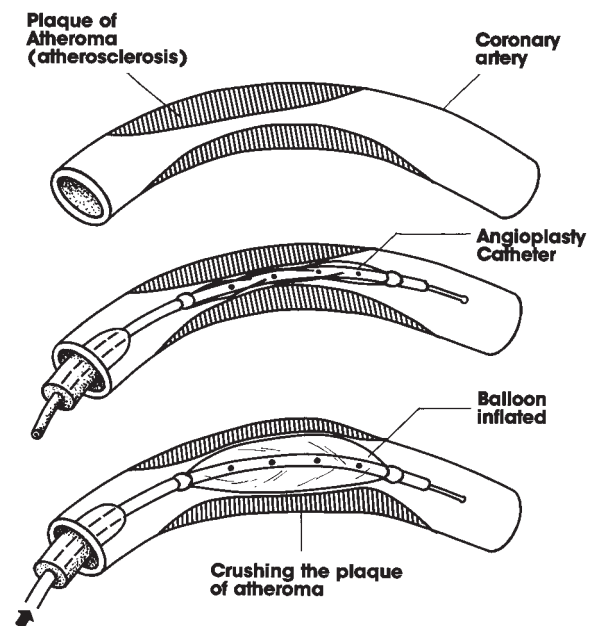

FIGURE 1 Coronary angioplasty.

stenosis), is obtained in less than 25% of patients after PTCA) is associated with a favorable late clinical outcome. Following angioplasty, the patient is monitored in the coronary care unit for about 24 h.

PTCA expands the coronary lumen by stretching and tearing the atherosclerotic plaque and vessel wall and to a lesser extent, by redistributing atherosclerotic plaque along its longitudinal axis. There is no evidence that the balloon compresses atheromatous plaques. PTCA has been transformed in the past decade with the development of angioplasty to assist with lesions exhibiting complex characteristics. The term percutaneous coronary intervention (PCI), is now used to include angioplasty with or without stent deployment. More than 700,000 patients in the United States had PCIs in 2004, far exceeding the number of patients who had coronary artery bypass graft (CABG) surgery. This method of treating coronary heart disease (CHD) is available in most major medical centers worldwide.

Atherosclerosis, however, usually affects several segments of the coronary arteries. As the disease advances, every effort must be made to halt its progress. All risk factors — smoking, high blood pressure, stress, cholesterol higher than 200 mg (5.2 mmol), and LDL cholesterol higher than 100 mg/dl (2.5 mmol) — must be controlled. Diet plus drug therapy is usually necessary to achieve this goal (see chapter entitled “Dyslipidemia.”)

II. INDICATIONS

A. Stable Angina

Patients with bothersome stable angina who do not achieve sufficient relief with medical therapy are candidates for coronary angioplasty, if they have any of the following:

1. One coronary artery obstructed (greater than 75%) by a discrete, preferably noncalcified atheromatous plaque without complex angiographic characteristics. Patients with symptoms and obstruction of the left anterior descending artery or right coronary artery before the artery gives off the first branch are the most ideal candidates. Procedural success rate exceeds 97% with these candidates and is associated with a low risk of early complications.
2. A broad range of obstructive lesions including obstructions in two and three arteries. This is now possible with increased experience and new steerable catheter systems. Success is less likely to occur in patients with obstruction in the circumflex artery or at lower points (distal) in the coronary arteries where there are irregular bends or turns.

B. Acute Heart Attacks

Patients with acute heart attacks may have the clot dissolved by drugs such as streptokinase or tissue-type plasminogen activator (t-PA); or they may undergo coronary angioplasty to dilate the obstructed artery and insertion of a stent. Often coronary angioplasty with stent implantation is performed without the use of thrombolytic agents. Several randomized clinical trials indicate that this aggressive interventional technique is superior to the use of thrombolytic agents, and it is advocated in centers that have facilities for rapid angiography and trained personnel for PCI (see the chapter Heart Attacks).

C. Unstable Angina and Non-ST Elevation Myocardial Infarction

I. Clinical Study — RITA 3 Investigators

Question posed: We will test the hypothesis that PCI is better than a conservative strategy in patients with unstable angina or non-ST elevation myocardial infarction.

Methods: A randomized multicenter trial of 1810 patients with acute coronary syndromes was used. Patients were assigned an early PCI or conservative strategy. The antithrombin agent in both groups was low molecular weight heparin, enoxaparin. Primary end points were a combined rate of death, nonfatal infarction, or refractory angina at four months and a combined rate of death or non fatal infarction at one year.

Results: At 4 months 86 (9.6%) of 895 patients in the PCI group had died or had a myocardial infarction or refractory angina versus 133 (14.5%) of 915 patients in the conservative group, $p=0.001$. This difference was mainly due to a halving of refractory angina in the intervention group. Death or infarction was similar in both groups at one year when symptoms of angina were improved with antianginal medications and significantly reduced with the interventional strategy ($p=0.0001$). The procedural success rate after PTCA was approximately 80% 20 years ago compared with approximately 97% in recent years, including success in women.

III. CONTRAINDICATIONS AND LIMITATIONS

Below is a list of contraindications and limitations for angioplasty.

1. A totally blocked artery cannot be cleared because the catheter cannot be positioned, and chronic total

occlusions are present in more than 20% of patients and are particularly frequent in patients with multi-vessel disease.

2. Disease of the left main coronary artery before it divides into the anterior descending presents too great a risk.
3. The obstruction is in the terminal part of the artery and cannot be reached by the balloon catheter.
4. A coronary artery bypass surgical team is not available; this is a relative contraindication; experienced operators in high-volume angiographic laboratories have low complication rates when compared with low-volume medical centers. The rare patient who requires bypass surgery because of complications can be stabilized and transported to an available surgical center. The recent availability of bail-out coronary stents has reduced the emergency CABG rate after PTCA to less than 1%.
5. Diabetics do not often obtain beneficial results; many diabetics have lesions in the coronary arteries that are irregular, diffuse, and long and not amenable to PCI. Surgery is more beneficial in most diabetics.

In greater than 25% of individuals with coronary artery disease (CAD), the obstruction in the artery is such that coronary angioplasty cannot be done. Eccentric morphology and ostial location increase the periprocedural risk. The presence of congestive heart failure or a low ejection fraction less than 30%, cardiogenic shock, renal insufficiency, multivessel CAD, and diabetes dictate a poor outcome, especially if a stent cannot be employed. The procedure is well tolerated in octogenarians, with single-vessel, discrete obstructive disease. Unfortunately, the increased prevalence of multivessel and diffuse disease and left ventricular dysfunction in the elderly diminishes the proportion of patients likely to have significant long-term benefits in comparison to surgery. PTCA and surgery are not competitive procedures and should be viewed as complementary.

IV. OUTCOME OF ANGIOPLASTY

Successful reopening of the artery is achieved in greater than 90% of cases, and with better blood flow, angina improves. The majority of patients return to work a few days later and have no recurrence of the angina for at least six months. Early complications are most often the result of abrupt vessel closure, defined as sudden occlusion of the target vessel during or shortly after PCI. This occurs in less than 2% of patients. The pathophysiology involves local vessel dissection with obstructive resection flaps accompanied by thrombus formation. This process usually

leads to myocardial infarction and need for bail-out stent or bypass surgery. The recent use of platelet IIb/IIIa receptor blockers and stenting has reduced the incidence of adverse outcomes of acute vessel closure.

Death occurs in less than 1% of cases. A heart attack occurs in less than 2% of cases, because the crushing and splitting of the plaque of atheroma exposes cells and substances that promote blood clotting. Thus clopidogrel, aspirin, or platelet receptor blockers are useful additions to the drug armamentarium to assist with successful PCI. In about 20% of patients, it is not possible to pass the catheter through the narrowed area. In about 10%, the dilation cannot be accomplished because the plaques are calcified and rock-hard. These complications are similar to those of CABG surgery.

The main limitation of PTCA is narrowing of the artery (restenosis) at the site of angioplasty. This occurs in approximately 33% of cases within 6 months of the procedure. In these patients chest pain returns. This figure has not changed much over the past 20 years. Despite intensive research to prevent restenosis, the problem has not been overcome.

The pathogenesis of restenosis in response to mechanical injury induced by balloon angioplasty is incompletely understood and is multifactorial. Several, pharmacologic agents have been tested in randomized controlled trials including aspirin, other antiplatelet agents, anticoagulants, antiproliferative agents, calcium antagonists, and folic acid. Only stent implantation has been shown to significantly decrease restenosis rates to approximately 25% at 6 months (see the chapter Stents). In the stent restenosis study (STRESS), restenosis rates were 32 and 42% percent in the stent and PTCA groups, respectively. Fortunately, these stenoses can be dilated more easily on the second procedure with relief of symptoms in many, but CABG is still frequently required in subsequent years. Additionally, the need for repeat revascularization tapers off rapidly after the second year. Still, restenosis may be clinically silent in more than 30% of patients.

Coronary angioplasty does not compete with CABG surgery. Approximately 25% of individuals cannot have coronary angioplasty or stents and must have CABG. Coronary angioplasty is much cheaper. The hospital stay is only one day, and patients can usually return to work within a few days. Of those who undergo angioplasty, approximately 85% are angina-free and able to be more active. Most important, the procedure is done in patients with stable or unstable angina mainly to relieve recurrent chest pain of angina. It has not been shown in randomized clinical trials to prolong life significantly or reduce the occurrence of myocardial infarction.

BIBLIOGRAPHY

- Chieffo, A., Stankovic, G., Bonizzoni, E. et al. Early and mid-term results of drug-eluting stent implantation in unprotected left main. *Circulation*, 111:791-795, 2005.
- Gersh, B. J., Braunwald, E., and Bonow, R. O. Chronic coronary artery disease. In *Heart Diseases*, sixth edition. E. Braunwald and D. P. Zipes, eds. W.B. Saunders, Philadelphia, 1272-1343, 2001.
- Machecourt, J., Bonnefoy, E., Vanzetto, G. et al. Primary angioplasty is cost-minimizing compared with pre-hospital thrombolysis for patients within 60 min of a percutaneous coronary intervention center. *J. Am. Coll. Cardiol.*, 45:515-524, 2005.
- RITA-2 Trial Participants. Coronary angioplasty versus medical therapy for angina: the second randomized intervention treatment of angina [RITA-2] trial. *Lancet*, 350:461, 1997.
- RITA Investigators. Interventional versus conservative treatment for patients with unstable angina or non ST elevation myocardial infarction: The British Heart Foundation RITA 3 randomized trial. *Lancet*, 360:743-51, 2002.
- Serruys, P. W., Ormiston, J. A., Sianos, G. et al. Actinomycin-eluting stent for coronary revascularization. A randomized feasibility and safety study: The ACTION trial. *J. Am. Coll. Cardiol.*, 44:1363-1367, 2004.
- Sousa, J. E., Costa, M. A., Tuzcu, E. M. et al. New frontiers in interventional cardiology. *Circulation*, 111:671-681, 2005.
- Spertus, J. A., Nerella, R., Kettlekamp, R. et al. Risk of restenosis and health status outcomes for patients undergoing percutaneous coronary intervention versus coronary artery bypass graft. *Circulation*, 111:768-773, 2005.
- van der Hoeven, B. L., Pires, N. M. M., Warda, H. M. et al. *Int. J. Cardiol.*, 99:9-17, 2005.
- Vasan, R. S., D'Agostino, R. B., Sr. et al. Age and time need not and should not be eliminated from the coronary risk prediction models. *Circulation*, 111:542-545, 2005.
- Vetrovec, G. W. et al. Optimizing percutaneous coronary intervention outcomes: The next steps. *Circulation*, 111:125-126, 2005.
- Wurdeman, R. L., Hilleman, D. E., and Mooss, A. N. Restenosis, the Achilles' heel of coronary angioplasty. *Pharmacotherapy*, 18:1024, 1988.

Angiotensin-Converting Enzyme Inhibitors/ Angiotensin Receptor Blockers

- I. ACE Inhibitors
- II. Angiotensin II Receptor Blockers (ARB)

GLOSSARY

ACE angiotensin-converting enzyme.

afterload arterial impedance, restriction to blood flow delivered from the left ventricle; force against which the myocardium contracts in systole; a major determinant of wall stress.

aldosterone a hormone produced by the adrenal glands.

arrhythmia general term for an irregularity or rapidity of the heartbeat, an abnormal heart rhythm.

converting enzyme the same as kininase II.

heart failure a failure of the heart muscle to pump sufficient blood from the chambers into the aorta; inadequate supply of blood reaches organs and tissues.

hyperkalemia high levels of serum potassium.

hypertrophy increase in thickness of muscle.

hypotension marked decrease in blood pressure, usually less than 95 mmHg.

infarct an area of cardiac necrosis caused by a disruption of blood supply due to blockage of the supply artery.

macula densa specialized cells in the kidney that control sodium balance.

media the middle wall of the arteries.

myocardial infarction death of an area of heart muscle due to blockage of a coronary artery by blood clot and atheroma; medical term for a heart attack or coronary thrombosis.

necrotic dead.

nephropathy kidney disease.

proteinuria a leak of protein from the kidney tubules into the urine.

I. ACE INHIBITORS

Since their introduction in 1980, angiotensin-converting enzyme (ACE) inhibitors, because of their unique

pharmacologic properties, have proven superior to other vasodilators in the management of heart failure and have come to play a key role in the therapy of hypertension. They are particularly useful in hypertensive patients with diabetes and proteinuria.

A. Mechanism of Action

The sodium concentration in the distal kidney tubules, sensed by the macula densa, controls the release of renin from the specialized juxtaglomerular cells located in the media of the afferent kidney arterioles. Renin is an enzyme that profoundly affects the cardiovascular system. It is a protease that cleaves the leucine 10–valine 11 bond from the circulating precursor angiotensinogen to form the decapeptide angiotensin I. ACE in the lungs cleaves histidine-leucine from angiotensin I, resulting in the formation of angiotensin II, which produces the effects listed below.

1. Vasoconstriction that is more intense than that caused by norepinephrine. This vasoconstriction occurs mainly in arterioles and, to a small degree, in veins. This action is more pronounced in skin and in the kidney but with some sparing of vessels in the brain and muscle.
2. Renal effects that include marked sodium reabsorption in the proximal kidney tubules.
3. Adrenal effects that cause the release of aldosterone, which enhances sodium and water reabsorption and potassium excretion in the renal tubule distal to the macula densa. Angiotensin II promotes release of catecholamines from the adrenal glands.
4. There is an increase in sympathetic outflow that facilitates ganglionic stimulation of the sympathetic nervous system.

Stimuli to the release of renin include: (1) a decrease in renal blood flow, hypotension, and reduction of intravascular volume; (2) sodium depletion or sodium diuresis; and (3) beta-adrenergic receptor activation.

ACE inhibitors are competitive inhibitors of angiotensin-converting enzyme and therefore prevent the conversion of angiotensin I to angiotensin II. This action causes the salutary effects listed below.

1. There is dilatation of arteries which causes a reduction in total systemic vascular resistance resulting in a fall in blood pressure and a reduction in afterload. This allows the left ventricle to pump blood more easily into the arterial system. Thus, the left ventricle has less work to do and this action prevents or improves heart failure (see the section Pathophysiology in the chapter Heart Failure).
2. There is potentiation of sympathetic activity and the release of norepinephrine is attenuated. This action causes further vasodilatation and reduction in afterload. The effect on the sympathetic nervous system and increased vagal tone prevents the increase in heart rate that is observed with other vasodilating agents. This important action is helpful in the management of heart failure where tachycardia causes increased work for the heart, and in hypertensive patients it prevents hypertrophy. Other vasodilating drugs are deleterious in these two conditions.
3. There is a reduction in aldosterone secretion that promotes sodium excretion and potassium retention. This action also prevents or improves heart failure. Unfortunately, aldosterone secretion is not completely suppressed. Agents that completely suppress aldosterone are being investigated.
4. Converting enzyme is the same as kininase II, which causes degradation of bradykinin to inactive peptides. The accumulation of bradykinin appears to stimulate the release of the important vasodilator nitric oxide (NO) and prostacyclin, which protect the endothelial lining of arteries. This accumulation also contributes to arterial dilation and a further decrease in peripheral vascular resistance and afterload. Thus, ACE inhibitors are more beneficial than angiotensin receptor blockers that do not have this salutary effect on bradykinin. Excessive bradykinin, however, may cause angioedema in susceptible individuals.
5. ACE inhibitors inhibit vascular superoxide production, and because superoxide reacts with nitric NO, ACE inhibitors appear to increase NO bioactivity. This action, although modest, is important in patients with coronary artery disease (CAD).
6. The modulation and adequacy of the neurohormonal response to the long-term administration of ACE inhibitors in heart failure appear to be associated with ACE gene polymorphism. Patients with heart failure and aldosterone escape have been shown to have a

- higher prevalence of DD genotype compared with patients who have normal aldosterone levels. A small study indicated that the antihypertensive response to ACE inhibition is more pronounced in subjects with ACE DD genotype than in those with ACE II genotype.
7. The ACE inhibitor captopril has been shown to modestly reduce high blood uric acid levels. This action may be important in an individual who is given diuretics that increase uric acid levels. Captopril may counteract some of this adverse effect.

B. Available ACE inhibitors

Below is a list of available ACE inhibitors.

1. Captopril — dosage 12.5–50 mg two or three times daily for hypertension and heart failure. The discovery of captopril, the first ACE inhibitor used in clinical practice, provided a major change in the management of heart failure.
2. Benazepril — dosage 5–30 mg daily
3. Cilazapril — dosage 1.25–5 mg daily
4. Enalapril — dosage 5–40 mg once daily
5. Fosinopril — dosage 5–50 mg once daily
6. Lisinopril — dosage 5–40 mg once daily
7. Perindopril — dosage 2–8 mg once daily
8. Quinapril — dosage 5–40 mg once daily
9. Ramipril — dosage 2.5 mg or up to 15 mg once daily
10. Trandolapril — dosage 0.5–4 mg once daily

Although there are more than ten ACE inhibitors currently available, it is unfortunate that their actions, indications, and adverse effects are similar. The newer agents have no beneficial effects over and above that of the older agents captopril, enalapril, and lisinopril that were available during the 1980s; thus the newer agents offer little added benefit to patients. Although there are subtle differences in absorption, elimination by the liver or kidney, and duration of action, these differences do not cause beneficial effects and do not merit further discussion.

C. Indications

I. Hypertension

These agents are most effective in patients with high serum renin activity. Younger white patients usually have a higher renin activity followed by older white patients, and these agents are particularly effective in the younger white patient. They are less effective in older white patients and, unfortunately, are not effective antihypertensive agents in people of African origin. The antihypertensive effects in

patients of Asian and Oriental origin have not been adequately studied. In addition, they cause effective blood pressure lowering in less than 60% of white individuals. The addition of a diuretic stimulates renin activity and increases the antihypertensive effects of ACE inhibitors. Nonetheless, it is not wise to use both agents in patients of African origin because a diuretic alone should suffice, and the addition of an ACE inhibitor should be considered superfluous (see the chapter Hypertension).

2. Heart Failure

The effectiveness of ACE inhibitors in reducing mortality and hospitalization in patients with severe heart failure was first proven in 1987 by the Cooperative North Scandinavian Enalapril Survival Study (CONSENSUS). The effectiveness of ACE inhibitors in reducing mortality and hospitalization in patients with a moderate degree of heart failure has been established in randomized clinical trials (RCTs) carried out during the 1990s. Worldwide there is an epidemic of heart failure. ACE inhibitors are used in combination with diuretics, beta-blockers, and digoxin in the majority of patients. Although these agents have provided much relief for suffering patients and have significantly decreased mortality, the effect is still modest and newer agents must be sought (see the section Pathophysiology in the chapter Heart Failure).

3. Acute Myocardial Infarction

ACE inhibitors are particularly useful in patients with an acute myocardial infarct and in whom the left ventricular function is moderately impaired. An infarct is an area of cardiac necrosis caused by a disruption of blood supply due to blockage of the supply artery. The necrotic muscle produces an area of weak heart muscle that may impair the overall contractile force of the powerful left ventricle and culminate in heart failure within days, months, or years.

During the first few hours and days following an acute myocardial infarct, probably because of weakness of the ventricular muscle, there is stimulation of the renin-angiotensin system resulting in increased stretch of the ventricular muscle and mild-to-moderate cardiac enlargement occurs. This deleterious process is called ventricular remodeling. The remodeling process is decreased significantly by ACE inhibitor therapy and morbidity and mortality is also decreased. Studies that show the efficacy of ACE inhibitors in patients with acute myocardial infarction are illustrated in the chapter Heart Attacks.

ACE inhibitors are recommended in most patients who have coronary heart disease, and particularly in diabetics.

This is based on the Heart Outcomes Prevention Evaluation (HOPE) study, which showed that in high-risk patients ramipril 10 mg, given for 4.5 years, caused a 22% reduction in the primary outcome of myocardial infarction, stroke, or death from cardiovascular causes.

The EUROPA study, which included 13655 patients with previous myocardial infarction (64%), angiographic evidence of coronary artery disease (61%), and coronary revascularization (55%) were randomized to perindopril 8 mg once daily or matching placebo. After a mean follow up of 4.2 years, perindopril administration caused improvement in outcome: about 50 patients needed to be treated for a period of 4 years to prevent one major cardiovascular event. Total mortality was 11% with perindopril, but this finding was not significant.

D. Research Implications

At the cellular level the renin-induced increased aldosterone levels promote myocardial fibrosis and collagen deposition that lead to a stiff ventricle and progressive decrease in normal left ventricular function. Treatment with ACE inhibitors appears to prevent nonmyocyte cellular proliferation and collagen deposition improving myocyte contractile function. Direct aldosterone antagonists are being investigated and research is needed in this important area. Direct rennin inhibitors and analogs require further research. Candidate molecules for therapeutic use have thus far been elusive.

ACE inhibitor therapy appears to have a favorable effect on atherosclerosis, which is the major cause of obstruction to the flow of blood through arteries resulting in infarcts that may occur in the heart or the brain (stroke). It appears that angiotensin II causes vasoconstriction and promotes the growth and migration of vascular smooth muscle cells into the media. An increase in smooth muscle cell enzyme causes an increase in free radical production, which promotes the oxidation of low-density lipoprotein (LDL) cholesterol and the progression of the atherosclerotic process. Other favorable effects include an improvement in endogenous fibrinolytic function and vasodilatation produced by bradykinins, prostaglandins, and the powerful vasodilator NO (see the chapter Atherosclerosis/Atheroma).

The incidence of sudden death appears to be reduced by ACE inhibitor therapy. Apart from a prevention of the deterioration in abnormal left ventricular function, patients treated with ACE inhibitors appear to have a reduction in arrhythmias. This may be explained by the decrease in the release of catecholamines that is increased by angiotensin II. Excess catecholamines have

been documented to cause serious arrhythmias, and their blockade by the beta-blocking drugs results in the proven beneficial effects of these agents. Patients carrying the ACE DD genotype with angiotensin II type 1C allele appear to be at higher risk for serious ventricular arrhythmias.

ACE 2 has recently been defined. The renin-angiotensin system is obviously much more complicated than extensive research over the past 20 years has suggested. The recently discovered enzyme ACE 2 has beneficial effects on the

function of the heart. ACE 2 converts angiotensin I to angiotensin 1-9 containing 9 amino acids that can be converted by ACE to a shorter peptide angiotensin 1-7, a dilator of blood vessels whereas angiotensin II containing 8 amino acids is a potent vasoconstrictor (see Fig. 1). Thus, ACE 2 appears to prevent the formation of excess angiotensin II, and this action is beneficial. It appears that ACE 2 increases cardiac contractility, has cardioprotective properties, and may be an important

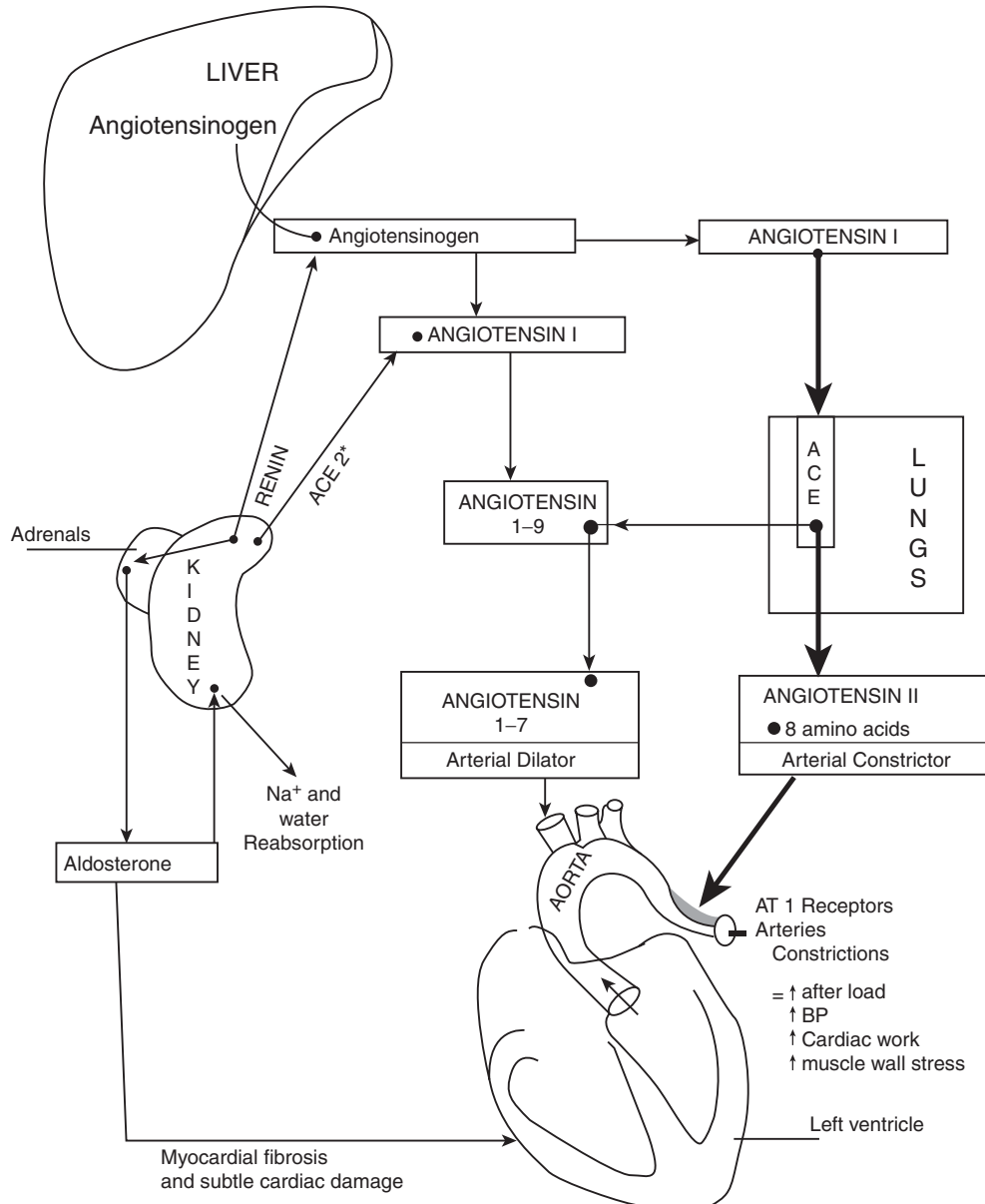

FIGURE 1 Renin- angiotensin- aldosterone system: action on the heart and arterial system. * ACE 2 may counteract some of the effects of ACE activity. Angiotensin II action, however, must prevail to maintain adequate blood pressure to the brain and vital organs during catastrophic events: nature’s way of survival. ACE = angiotensin converting enzyme; AT1 = angiotensin II activates two subtypes of angiotensin II receptors: AT1 and AT2, but only AT1 mediates clinical effects of angiotensin II.

regulator of cardiac function. Intensive research is required to obtain compounds that could increase the production of beneficial ACE 2 and decrease the deleterious actions of angiotensin II.

E. Adverse Effects

Below is a list of adverse affects of ACE inhibitors.

1. Hypotension may occur if the dose of ACE inhibitor is excessive, particularly if a diuretic is used before the addition off the ACE inhibitor. Lightheadedness, dizziness, and a faint feeling may occur. The initial dose should be small in elderly patients and in patients with heart failure.
2. Kidney failure may become worse if hypotension occurs or if the patient has severe obstruction in one renal artery or tight renal artery stenosis. Fortunately, renal artery stenosis is uncommon.
3. Hyperkalemia may occur if kidney failure is progressive or if a potassium-sparing diuretic, potassium supplements, or salt substitutes are added to the treatment regimen.
4. Cough occurs in up to 20% of patients; it is sufficiently bothersome to promote the discontinuation of medications in about 10% of treated patients. Cough occurs because of the accumulation of bradykinin.
5. Loss of taste has been reported in up to 7% of patients.
6. Extensive skin rash with severe itching may occur in greater than 10% of patients.
7. Angioedema is a life-threatening complication that occurs in approximately 0.8% of patients. Bradykinin and kallidin mediate hereditary angioedema. ACE inhibition results in the accumulation of bradykinin which can cause angioedema. Swelling of the eyelids, lips, and tongue may occur. Most important, swelling of the upper airway may obstruct air entry to the lung and death can occur if treatment is not immediately available.

F. Interactions

Lithium levels may increase, and interactions may occur with immunosuppressive agents and those that alter the immune response.

II. ANGIOTENSIN II RECEPTOR BLOCKERS

Angiotensin II receptor blockers (ARBs) have beneficial effects similar to those of ACE inhibitors, but angioedema

occurs less, and cough rarely occurs compared to ACE inhibitors.

A. Mechanism of Action

Angiotensin I can be formed by nonrenin enzymes such as cathepsin or tonin. Angiotensin I may be converted to angiotensin II by trypsin, cathepsin, or the heart chymase, but the exact contribution of these alternative pathways to the formation of angiotensin II remains unclear. Angiotensin II activates two subtypes of angiotensin II receptors, AT1 and AT2, but only the AT1 receptor mediates all the known clinical effects of angiotensin II described above in Section I. AT1 receptors are present in the heart, kidney, vascular smooth muscle cells, brain, adrenal glands, platelets, the placenta, and in adipocytes. The AT2 receptor affects the inhibition of cell growth, promotion of cell differentiation, tissue repair, apoptosis, and perhaps to a small degree, the production of bradykinin, NO, and prostaglandins in the kidney. Other effects may emerge with further research. The AT2 receptors have been cloned and are present at a low level in the adrenal gland, heart, brain, kidney, and uterus.

ARBs were expected to have clinical effects that would be equal to or superior to those observed with ACE inhibitors. Clinical trials during the past five years have indicated that these agents reduce microalbuminuria and glomerulopathy and delay time to end-stage renal disease in patients with type 2 diabetes. ACE inhibitors have been shown to be useful in causing similar beneficial effects in patients with type 1 diabetes, but evidence in type 2 diabetic nephropathy is not convincing. Direct comparison of ARBs with ACE inhibitors in this subset of patients has not been tested. Head-to-head trials of ARBs and ACE inhibitors in diabetic nephropathy need to be conducted to determine their respective place in renoprotection.

Dual blockade of the renin-angiotensin-aldosterone system with both candesartan 16 mg once daily and lisinopril 20 mg daily has been shown to be better than either treatment alone in reducing blood pressure and better than candesartan alone in reducing microalbuminuria.

B. Available Angiotensin Receptor Blockers

Several selective AT1 receptor blockers have become available. They have a high affinity for AT1 receptors and negligible affinity for AT2 receptors. These include:

1. Candesartan — dosage 4–16 mg daily, maximum 32 mg once daily
2. Irbesartan — dosage 150–300 mg once daily

3. Eprosartan — dosage 300–400 mg twice daily
4. Losartan — dosage 25–100 mg once daily
5. Telmisartan — dosage 28–80 mg once daily
6. Valsartan — dosage 40–160 mg once daily

C. Clinical Trials

1. The Losartan Heart Failure Survival Study ELITE II

Study question: Is losartan superior to captopril in improving survival?

Methods: A double-blind RCT of 3152 patients with heart failure, was randomly assigned losartan (1578) titrated to 50 mg once daily or captopril (1574) titrated to 50 mg three times daily.

Results: At a median follow up of 555 days there were no significant differences in mortality or sudden death between the two treatment groups.

Perspective: Losartan was not superior to the ACE inhibitor captopril in improving survival in patients with heart failure. Fewer patients in the losartan group discontinued study treatment, however, because of adverse effects (9.7 vs. 14.7%; $p < 0.001$).

2. The Effect of Irbesartan on the Development of Diabetic Nephropathy in Patients with Type 2 Diabetes

Study question: What is the effectiveness of irbesartan in delaying or preventing the development of diabetic nephropathy in hypertensive patients with type 2 diabetes and persistent microalbuminuria?

Methods: 590 hypertensive patients with type 2 diabetes and microalbuminuria were enrolled in this RCT. One group received 150 mg irbesartan, while a second group received 300 mg, and the placebo group received other antihypertensive agents.

Results: Ten of the 194 patients in the 300-mg group (5.2%) and 19 of the 195 patients in the 150-mg group (9.7%) reached the primary end point as compared with 30 of the 201 patients in the placebo group (14.9%; $p < 0.001$). The primary end point was persistent with more severe albuminuria with an albumin excretion rate that was greater than 200 μg per minute and at least 50% higher than the baseline level. *The 150-mg dose was not significantly different from the placebo. Thus, the 300-mg dosage is recommended.*

Perspective: ACE inhibitors have been shown to slow the progression of diabetic nephropathy in patients with type 1 diabetes and microalbuminuria. ACE inhibitors

have not been tested in patients with type 2 diabetes. Irbesartan is renoprotective in hypertensive patients with type 2 diabetes and microalbuminuria, and the beneficial effect is independent of the drug's ability to lower blood pressure. A similar RCT with another ARB showed similar beneficial effects.

3. CHARM Program of Trials

a. The CHARM–Alternative Trial

Methods: In this study 2028 patients were used to examine the effects of the ARB candesartan in patients with reduced left ventricular ejection fraction less than 40% who were intolerant of ACE inhibitors.

Methods: Treated patients received candesartan 4–8 mg titrated to 32 mg once daily plus the treatment given to placebo patients. Standard heart failure therapy includes diuretics, beta-blockers, digoxin, and spironolactone (85, 54, 45, and 24%, respectively).

Results: After 33.7 months follow up, patients administered candesartan were 23% less likely to experience cardiovascular death or hospitalization for heart failure compared with those who received placebo (40% vs. 33%; $p = 0.0004$).

b. The CHARM–Added Trial

Methods: This trial examined the effect of candesartan on patients who were already on ACE inhibitors, the majority of whom were on a beta-blocker.

Results: After 41 months of follow up, patients receiving candesartan were 15% less likely to experience the primary end point compared with those given placebo (42% vs. 37.9%; $p = 0.0011$). This result occurred regardless of whether or not patients were on a beta-blocker and independent of the dose of ACE inhibitor used. The addition of candesartan to an ACE inhibitor plus a beta-blocker leads to further clinically important reduction in cardiovascular death and hospitalization for heart failure. When the combination of candesartan and ACE inhibitors is administered, however, monitoring of serum creatinine and hyperkalemia is necessary. This is even more important if eplerenone or spironolactone are used in the heart failure treatment regimen.

There is no unfavorable interaction when candesartan and a beta-blocker are used in combination as opposed to that shown with a losartan beta-blocker combination. Most important, ARBs like beta-blockers have subtle and important clinical differences that must be defined.

BIBLIOGRAPHY

- Bourassa, M. G. et al. Angiotensin II inhibition and prevention of atrial fibrillation and stroke. *J. Am. Coll. Cardiol.*, 45:720–721, 2005.
- Burnier, M. Angiotensin II type 1 receptor blockers. *Circulation*, 103:904–91, 2001.
- CHARM: Granger, C.B., McMurray, J.J.V., Yusuf, S. et al. for the CHARM Investigators and Committees. Effects of candesartan in patients with chronic heart failure and reduced left ventricular systolic function intolerant to angiotensin converting enzyme inhibitors; the CHARM-alternative trial. *Lancet*, 362:772–76, 2003.
- EUROPA: The European trial on reduction of cardiac events with perindopril in stable coronary artery disease investigators. Efficacy of perindopril in reduction of cardiovascular events among patients with stable coronary artery disease: Randomized double-blind placebo-controlled multicenter trial. *Lancet*, 362:782–88, 2003.
- Heagerty, A. M. et al. Influence of changes of blood pressure on vascular angiotensin II receptor subtype expression. *Circulation*, 111:956–57, 2005.
- HOPE Investigators. Yusuf, S, Sleight, P, Progue, J. et al. The Heart Outcomes Prevention Evaluation Investigators: Effects of angiotensin converting enzyme inhibitor, ramipril, on death from cardiovascular causes, myocardial infarction, and stroke in high-risk patients. *N. Engl. J. Med.*, 342:145, 2000.
- Ishani, A., Weinhandl, E., Zhao, Z. et al. Angiotensin-converting enzyme inhibitor as a risk factor for the development of anemia, and the impact of incident anemia on mortality in patients with left ventricular dysfunction. *J. Am. Coll. Cardiol.*, 45:391–399, 2005.
- Khan, M. Gabriel *ACE Inhibitors in Cardiac Drug Therapy*, sixth edition. W.B. Saunders, Philadelphia, 2003.
- Munzel, T., and Keaney, J.F. Are ACE inhibitors a “magic bullet” against oxidative stress? *Circulation*, 104:1571–1574, 2001.
- Parving, H.-H., Lenhart, H., Brochner-Mortensen, J. et al. for the irbesartan in patients with type II diabetes and microalbuminuria study group: The effect of irbesartan on the development of diabetic nephropathy in patients with type II diabetes. *N. Engl. J. Med.*, 345:870, 2001.
- Pitt, B., Poole-Wilson, P.A., Segal, R. et al. ELITE II — effect of losartan compared with captopril on mortality on patients with symptomatic heart failure: Randomized trial. The Losartan Heart Failure Study. *Lancet*, 255:1582, 2000.
- Wachtell, K., Lehto, M., Gerdtts, E. et al. Angiotensin II receptor blockade reduces new-onset atrial fibrillation and subsequent stroke compared to atenolol. *J. Am. Coll. Cardiol.*, 45:712–719, 2005.

Antihistamines

I. Histamine Antagonists

GLOSSARY

arrhythmia general term for an irregularity or rapidity of the heartbeat, an abnormal heart rhythm.

palpitation rapid heart rate; the patient feels the heartbeat.

THESE WELL-KNOWN ANTIALLERGY MEDICATIONS may occasionally cause an increase in the pulse rate because they have an atropine-like effect. In some individuals, the heart rate may become rapid. These sensations, called palpitations and caused by arrhythmia, subside over time and usually cause no harm. Patients with angina, however, should be cautious with the use of antihistamines, because an increase in heart rate may trigger an attack of angina. Blood pressure is usually not increased by antihistamine use, but many remedies containing antihistamines contain the decongestant phenylpropanolamine, which elevates blood pressure. This should be avoided by patients with hypertension and angina.

I. HISTAMINE ANTAGONISTS

These newer agents differ from the general group of antihistamines in that they are more selective blockers of specific histamine H1 receptors. They do not produce the bothersome side effects usually noted with antihistamines, such as drowsiness and dry mouth. Unlike antihistamines,

they are safe in patients with glaucoma or enlargement of the prostate. Older histamine H1 antagonists include astemizole and terfenadine. These agents are generally safe, but abnormal heart rhythms, palpitations, transient loss of consciousness, and cardiac arrest have been reported. The electrocardiographic findings include an increase in the QT interval. Agents that also increase the QT interval should not be taken concurrently with these H1 antagonists.

These agents are broken down in the liver. Thus, patients with liver disease or those using drugs that interfere with liver enzymes, such as the antibiotic erythromycin, may be predisposed to arrhythmias. Patients taking agents with a similar chemical structure — fluconazole, itraconazole, and metronidazole (Flagyl) — may have a greater predisposition to developing bothersome, and even serious, abnormal heart rhythms. Patients with heart disease, those on diuretics or agents that reduce the levels of potassium in the blood, should not take astemizole or terfenadine. The antibiotics erythromycin, azithromycin, and clarithromycin or similar types of antibiotics should not be taken concurrently.

Newer histamine antagonists such as cetirizine and loratadine have not been noted to cause serious arrhythmias, but surveillance and caution are needed in patients with heart disease or in those taking diuretics and other substances that can lower blood potassium.

BIBLIOGRAPHY

Khan, M. Gabriel Effects of Drug Interactions. In *Cardiac Drug Therapy*, sixth edition. W. B. Saunders, Philadelphia, 2003.

Antioxidants

- I. Statins
- II. Vitamin E
- III. Vitamin C
- IV. Beta-Carotene
- V. Mediterranean Diet
- VI. Dietary Plant-Derived Flavonoids
- VII. French Red Wine
- VIII. Probucol

GLOSSARY

atherosclerosis same as atheroma, raised plaques filled with cholesterol, calcium, and other substances on the inner wall of arteries that obstruct the flow of blood; the plaque of atheroma hardens the artery, hence the term atherosclerosis (sclerosis = hardening).

cardioprotection protection of the heart from serious events that include coronary artery disease and its complications, angina, myocardial infarction, and heart failure.

flavonoid any of a large group of crystalline compounds found in plants.

myocardial infarction death of an area of heart muscle due to blockage of a coronary artery by blood and atheroma; medical term for a heart attack or coronary thrombosis.

STEINBERG ET AL. WERE AMONG THE FIRST TO indicate that modified low-density lipoprotein (LDL) cholesterol could be responsible for the accumulation of lipid within macrophages, a crucial step in the early formation of atheromatous plaques.

Only some antioxidants prevent the oxidation of LDL cholesterol, which plays an important role in the pathogenesis of the atherosclerotic process and its progression to blockage of arteries (see the chapter Atherosclerosis/Atherothrombosis). The harmful effect of LDL cholesterol is augmented by oxidized LDL cholesterol particles. Prevention of the oxidation of LDL cholesterol particles by chemical agents and natural products is an area of intensive research. Natural substances and chemical

compounds, which may protect lipids from attack by oxygen free radicals increase resistance to lipid peroxidation, reverse endothelial dysfunction, and increase nitric oxide (NO) mediated vasodilation will remain an interesting area of research and development, despite the negative results observed in many clinical trials.

It is important to emphasize that it is not certain exactly where and how LDL cholesterol gets oxidized within the human body. More important, vitamin C is a water-soluble vitamin and is thus confined to the extracellular fluids but vitamin E gains entry into lipoproteins. It is known that large doses of beta-carotene do not prevent LDL oxidation. Thus, antioxidants have subtle and important differences that impact on their probable therapeutic benefits.

After the past few years of conflicting results, the critical question remains: Do antioxidants actually work? The role of antioxidants in protecting people against heart disease remains controversial. There appears to be little doubt, however, that antioxidants present in the Mediterranean diet possess cardioprotective effects; recent experimental work indicates that French red wines are cardioprotective beyond the effect on increasing HDL cholesterol. (See chapter entitled "Alcohol and the Heart.")

I. STATINS

Statins are well-known, cholesterol-lowering agents. They are competitive inhibitors of 3-hydroxy-3-methylglutaryl coenzyme A (HMG-CoA) reductase, which is the key enzyme catabolizing the early rate-limiting step in the biosynthesis of cholesterol within the hepatocyte. They lower LDL cholesterol in blood and thus prevent heart attacks and death from myocardial infarction as well as strokes. More important, statins have been shown to prevent lipoprotein oxidation, and it is believed that some of their salutary effects may be related to this action. They appear to improve survival in patients with ischemic and non-ischemic heart failure. Nitric oxide synthesis is diminished in heart failure; statins enhance endothelial NO synthase (eNOS) activity and improve endothelial function (see the section Statins in the Dyslipidemia chapter).

II. VITAMIN E

Antioxidant nutrients, particularly vitamin E, are still widely used with the hope of preventing cancer, heart disease, and dementia. Although, clinical trials have not shown protection from cancer, the correct “protective” dose may not have been used in some trials. Also, the partially favorable effect of vitamin E on amyloid deposition in the brain and its effect on dementia remains to be clarified.

Vitamin E is a fat-soluble vitamin found in vegetables and seed oils, particularly soybean and safflower, and sunflower seeds, corn, nuts, whole grains, and wheat germ. Increased dietary intake has not been shown to decrease the incidence of heart disease or cancer. With aging, however, the vitamin E content of blood platelets decreases; this action may predispose individuals to clumping of platelets and cause a risk of clotting. The elderly may thus benefit from some vitamin supplements.

A. Clinical Studies

1. United States Study

A large-scale study in the United States showed a reduction in the relative risk of coronary heart disease only in middle-aged women who took vitamin supplements for more than two years. In men, a borderline beneficial effect was observed for those taking above 100 IU daily for over two years.

2. The Health Professionals Follow-Up Study

This study included approximately 40,000 men. It showed that males who consumed more than 400 IU daily had a 40% reduction in the risk of heart disease compared with individuals with the lowest intake of vitamin E. A study involving 121,000 nurses reported a 34% decrease in risk of heart disease among women taking greater than 200 IU daily.

3. Cambridge Heart Antioxidant Study

The Cambridge Heart Antioxidant Study (CHAOS) examined the effect of vitamin E in patients with angiographic-proven severe heart disease. This study randomized 2002 patients to vitamin E, 400–800 IU or placebo. The mean age of the patients was 61.8 years.

The baseline characteristics of patients are shown in Table 1. Most important, patients were enrolled immediately after coronary angiography. More than 62% had

severe triple- or double-vessel disease; more than 90% of patients had angina, evidence of reversible myocardial ischemia, or both and approximately 9% were diabetics. Thus, this was a high-risk group of patients.

After median follow up of 1.4 years, there was a benefit in the combined end point of nonfatal myocardial infarction and cardiovascular death with a risk reduction of 47% (41 vs. 64 events). Patients receiving vitamin E had a remarkable 77% reduction in myocardial infarction (41 in the placebo vs. 14 in the vitamin E group). The powerful cholesterol-reducing agents, statins, have not shown such a decrease in nonfatal heart attacks. This study appears to have been condemned because no effect on cardiac mortality was observed. The benefit was due mainly to reduction in risk of nonfatal myocardial infarction. It is surprising that this well-conducted study is unjustly discarded, mainly because of the results of the HOPE study (see Section I.A.6 below). It appears that some experts believe that the prevention of nonfatal myocardial infarction in high-risk patients is of no consequence. The beneficial effects of treatments that possess marginal but important beneficial effects may only be observed with correct dosing, and only after several years of intake of the particular substance administered to patients at high risk.

4. The SPACE Study

The Secondary Prevention with Antioxidants of Cardiovascular Disease in End-Stage Renal Disease (SPACE) study is a study of a small, high-risk group of patients: 196 patients on hemodialysis with cardiovascular disease followed for a median of 519 days. The vitamin E group decreased the relative risk for a composite primary end point of myocardial infarction, ischemic stroke, peripheral vascular disease, and unstable angina by 54%.

A similar study involving a group of 40 cardiac transplant patients treated for one year with 400 IU of vitamin E given twice daily for one year caused less coronary progression compared with those not given vitamins ($p = 0.008$). In cardiac transplant patients accelerated atherosclerosis commonly occur.

5. Alpha Tocopherol Beta-Carotene Cancer Prevention Trial

In this trial men were randomized to receive only 50 mg daily of vitamin E, beta-carotene 20 mg daily, both vitamins, or placebo. After mean follow up of 5.3 years the four groups had similar rates of major coronary events, but there appeared to be an increased risk of hemorrhagic stroke in individuals administered vitamin E. The use of

low doses of different sources of vitamin E may have accounted for the differences in results between this study and the CHAOS study.

6. Heart Outcomes Prevention Evaluation Trial

The Heart Outcomes Prevention Evaluation (HOPE) trial enrolled a total of 2545 women and 6996 men 55 years of age or older at high risk for cardiovascular events because they had cardiovascular disease or diabetes in addition to one other risk factor. Patients were randomly assigned to receive either 400 IU of vitamin E daily from natural sources or matching placebo and either an angiotensin-converting enzyme (ACE) inhibitor or matching placebo for a mean of 4.5 years. The primary outcome was a composite of myocardial infarction, stroke, and death from cardiovascular causes. This remarkable study, however, was not an independent study of vitamin E. Most important, this widely quoted study included 38% diabetics (the average in most cardiovascular studies worldwide range from 7 to 12%). This percentage of diabetics does not represent the population at large. In addition, there is only a hypothetical risk for the study group; patients were not selected after coronary angiograms as was done for the CHAOS study; thus, the HOPE studied apples and oranges.

In this study a total of 772 of the 4761 patients assigned to vitamin E (16.2%) and 739 of the 4780 (15%) assigned to placebo had a primary outcome event. There were no significant differences in the number of deaths from vascular causes or fatal or nonfatal myocardial infarction. This large, widely touted randomized study, despite its methodology, unfortunately is likely to put an end to further clinical trials of vitamin E.

7. Vitamin E in Heart Failure

Randomized trials to examine the benefits of vitamin E have not been carried out in patients with heart failure. A small study of patients with dilated cardiomyopathy showed that the combination of vitamin E and C reduced plasma levels of malondialdehyde and superoxide anion and elevated the levels of antioxidant enzymes. The combined treatment with vitamin C and E has been shown to suppress neutrophil-mediated free radical production and lower blood lipid peroxidation product in patients with acute myocardial infarction. The role of vitamin E either alone or in combination with vitamin C in patients with heart failure deserves to be further studied, particularly because oxidative stress is present in the failing heart.

Gotto et al. emphasized that “we cannot discount the oxidation hypothesis in human atherosclerosis, and experiments to date have only illustrated the difficulties in testing this complex issue.”

III. VITAMIN C

Although vitamin C, ascorbic acid, is one of the most important antioxidants in extracellular fluids, it traps peroxyl radicals and inhibits lipid peroxidation. Several studies indicate that there is no apparent benefit in the prevention of cardiovascular disease with use of vitamin C.

1. The Nurse's Prospective Observational Study of 87,000 female nurses followed for a mean of 8 years and health professionals study in which 39,000 male health professionals were followed for 4 years showed no reduced risk for coronary revascularization, myocardial infarction, or death from coronary heart disease among persons using vitamin C.
2. A randomized controlled trial carried out in China found no reduction in total mortality or mortality from cardiovascular diseases in 29,584 healthy adults given vitamin C over 5 years.

Vitamin C is known to have antioxidant properties, but its effects appear to be modest and may only be observed in patients at very high risk; this includes patients with heart failure in whom vitamin C has not been adequately tested, particularly in combination with vitamin E. Ascorbic acid has been shown to normalize endothelial function by restoring NO-mediated vasodilatation of endothelium in patients with hypertension, but it does not cause a lowering of blood pressure.

IV. BETA-CAROTENE

Results of several clinical trials indicated that beta-carotene supplementation is not beneficial in the prevention of cardiovascular disease or its complications.

1. The Carotene and Retinol Efficacy Trial (CARET) trial included 8314 men and women with a history of cigarette smoking or occupational exposure to asbestos receiving beta-carotene (30 mg per day), and retinol (25,000 IU per day). This trial was stopped early because the incidence of mortality from lung cancer was excessive. However, the population studied in these trials was already at high risk for lung cancer.
2. The physician's health study randomized 22071 male physicians taking beta-carotene (50 mg per day),

aspirin 325 mg, both, or neither for 12 years. There were no cardiovascular benefits from beta-carotene administration.

3. In the Alpha Tocopherol Beta-Carotene Cancer Prevention Trial (ATBC) the effects of daily doses of 50 IU of vitamin E, 20 mg of beta-carotene, both, or placebo for 5 to 8 years in 29133 smokers with a previous myocardial infarct were monitored. The study found no reduction in risk for major coronary events with any of the antioxidants.

V. MEDITERRANEAN DIET

The Mediterranean diet contains a substantial amount of antioxidants and has been shown to be substantially cardioprotective. However, there are many other cardioprotective facets in this diet, including an abundance of beneficial alpha-linolenic acid (see the chapter Diets and Heart Disease).

VI. DIETARY PLANT-DERIVED FLAVONOIDS

These naturally derived products from several sources including red grape juice, red wine, soy products, and nuts (particularly almonds, walnuts, and hazel nuts), are receiving attention for their antioxidant and cardioprotective properties.

A. Purple Grape Juice

1. Freedman et al. Study

Methods: The effect of purple grape juice supplementation was assessed *in vivo* in 20 healthy subjects. Welch's grape juice, 7 ml/kg, was administered for 14 days and used on isolated platelet preparations. Major polyphenolic compounds in purple grape juice were isolated and separated into four classes: flavonols (quercetin), cinnamic acids, anthocyanins, and polyflavan-3-ols (tannins).

Results: Incubation of platelets with purple grape juice led to reduced dependent inhibition of adenosine diphosphate induced aggregation and a dose-dependent decrease in superoxide release, which was associated with an increase in platelet NO production. Similar *in vivo* findings occurred following two weeks of purple grape juice consumption. Plasma antioxidant activity increased by 50%.

Conclusion: Both oral supplementation and *in vitro* incubation with purple grape juice decreases platelet

aggregation, increases platelet-derived NO, and decreases superoxide production. The suppression of platelet-mediated thrombosis represents a potential mechanism for the beneficial effects of purple grape products, independent of alcohol consumption.

VII. FRENCH RED WINE

French red wine appears to be more cardioprotective than wine from other countries. Although the data for differences in red and white wine remain controversial, and it appears that all alcoholic beverages carry some cardioprotective properties, it seems that French red wine possesses further cardioprotective properties.

In a German study by Wallerath et al., three German and six French red wines were assessed. The study tested the effect of red wine on endothelial-type NO synthase expression, eNOS expression, and eNOS activity in human endothelial cells. Incubation of endothelial cells with red wines from France upregulated eNOS, mRNA and protein expression. In contrast, red wines from Germany showed little or no effect on eNOS expression. Endothelial cells treated with French red wine produced up to three times more bioactive NO than control cells. French red wines increased the activity of other eNOS promoters, with a transstimulated sequence located in the proximal 326 bp of the promoter sequence. The eNOS mRNA stability was also increased by red wine. No significant difference in the Enos mRNA expression could be detected between the "en barrique" (matured in oak barrels) and "non-barrique" (matured in steel tanks) produced French wines.

Long-term, French red wine consumption in low doses could involve an upregulation of eNOS expression. This would lead to moderate, but sustained elevations of vascular NO.

The numerous phenolic acids, polyphenols, and flavonoids contained in French red wines are likely constituents probably mediating the expressional upregulation of Enos. French red wines contain high polyphenol levels compared with wines from other regions leading to an enhanced production or bioactive NO. Apart from the other known beneficial effects of red wine on dyslipidemia, the enhanced NO activity could contribute to further cardiovascular protection beyond that observed with other alcoholic beverages. In addition, the following observation may be relevant: red wine may have specific anti-inflammatory and antiproliferative effects. The acute administration of red wine reduces the increase in nuclear factor κ B (NF- κ B) responsible for promoting the expression of several inflammatory genes resulting from a

high-fat meal, a finding that has not been observed for vodka. This finding and the study by Cuveas et al. suggested that red wine may be particularly cardioprotective in individuals consuming high-fat diets. These two important findings may explain the French paradox (see the chapter Alcohol and the Heart).

VIII. PROBUCCOL

Two small studies have demonstrated that probucol, a drug used in the 1970s for lowering serum cholesterol, which was abandoned because of adverse effects, has important additional antioxidant properties. Probuccol significantly reduces restenosis when administered one month before and continued for six months after percutaneous transluminal coronary angioplasty (PTCA). The small group, 317 patients, used in these studies limits the conclusions regarding the benefits of this drug.

Because several clinical trials during the past 20 years have not altered the restenosis rate after PTCA, which still remains at more than 33%, any agent or natural product that reduces restenosis rates would be a welcome addition to the cardiologic armamentarium.

BIBLIOGRAPHY

- Appeldoorn, C. C. M., Bonnefoy, A., Bianca, C. H. et al. Gallic acid antagonizes P-Selectin – mediated platelet – leukocyte interactions: Implications for the French paradox. *Circulation*, 111:106–112, 2005.
- ATBC: The Alpha Tocopherol Beta-carotene Prevention Study Group. The effect of vitamin E and beta-carotene on the incidence of lung cancer and other cancers in male smokers. *N. Engl. J. Med.*, 330:1029–35, 1994.
- Blanco-Colio, L. N., Valderrama, M., Alvarez-Sala, L. A. et al. Red wine intake prevents nuclear factor- κ B activation in peripheral blood mononuclear cells of healthy volunteers during postprandial lipemia. *Circulation*, 102:1020–6, 2000.
- Brown, B. G., Crowley, J. et al. Is there any hope for vitamin E? *JAMA*, 293:1387–1390, 2005.
- Cuveas, A. M., Guasch, V., Castillo, O. et al. A high-fat diet induces and red wine counteracts endothelial dysfunction in human volunteers. *Lipids*, 35:143–8, 2000.
- Freedman, J. E., Parker, C., and Li, L. Select flavonoids and whole juice from purple grapes inhibit platelet function and enhance nitric oxide release. *Circulation*, 103:2792–8, 2001.
- GISSI-Prevenzione Investigator Group (Gruppo Italiano per lo Studio della Sopravvivenza nell'Infarto Miocardico). Dietary supplementation with *n*-3 polyunsaturated fatty acids and vitamin E after myocardial infarction: results of the GISSI-Prevenzione trial. *Lancet*, 354:447–55, 1999.
- Gotto, A. M. Antioxidants, statins and atherosclerosis. *J. Am. Coll. Cardiol.*, 41:120, 5–10, 2003.
- Heart Protection Study Collaborative Group. MRC/BHF Heart Protection Study of antioxidant vitamin supplementation in 20,536 high-risk individuals: A randomized placebo-controlled trial. *Lancet*, 360:23–33, 2002.
- Henriksen, T., Mahoney, E. M., and Steinberg, D. Enhanced macrophage degradation of low-density lipoprotein previously incubated with cultured endothelial cells: Recognition by receptors for acetylated low-density lipoproteins. *Proc. Natl. Acad. Sci. U.S.A.*, 78:6499–503, 1981.
- Horwich, T. B., MacLelland, R., and Fonarow, G. C. Statin therapy is associated with improved survival in ischemic and nonischemic heart failure. *J. Am. Coll. Cardiol.*, 43:642–648, 2004.
- Sacks, F. M. et al. Dietary phytoestrogens to prevent cardiovascular disease: Early promise unfulfilled. *Circulation*, 111:385–387, 2005.
- Shite, J., Fuzhong, Q., Wei, M. et al. Antioxidant vitamins in dilated cardiomyopathy. *J. Am. Coll. Cardiol.*, 38:1734–40, 2001.
- Singh, R. B., Niaz, M. A., Rastogi, S. et al. Usefulness of antioxidant vitamins in suspected acute myocardial infarction (the Indian experiment of infarct survival-3). *Am. J. Cardiol.*, 77:232–6, 1996.
- Steinberg, D., Parthasarathy, S., Carew, T. E. et al. Beyond cholesterol: Modifications of low-density lipoprotein that increase its atherogenicity. *N. Engl. J. Med.*, 320:915–924, 1989.
- Stephens, N. G., Parsons, A., Schofield, P. M. et al. Randomized controlled trial of vitamin E in patients with coronary disease: Cambridge Heart antioxidant study (CHAOS). *Lancet*, 347:781–6, 1996.
- Szmitko, P. E., Verma, S. et al. Red wine and your heart. *Circulation*, 111:e10–e11, 2005.
- Tardif, J. C., Cote, G., Lesperance, J. et al. Probuccol and multivitamins in the prevention of restenosis after coronary angioplasty. *N. Engl. J. Med.*, 337:365, 1997.
- The Heart Outcomes Prevention Evaluation [HOPE] Study Investigators. Vitamin E supplementation and cardiovascular events in high-risk patients. *N. Engl. J. Med.*, 342:154–60, 2000.
- The HOPE and HOPE-TOO Trial Investigators.* et al. Effects of long-term vitamin E supplementation on cardiovascular events and cancer: a randomized controlled trial. *JAMA*, 293:1338–1347, 2005.
- Vogel, R. A. Vintners and vasodilators: Are French red wines more cardioprotective? *J. Am. Coll. Cardiol.*, 41:479–81, 2003.
- Wallerath, T., Poleo, D., Li, H. et al. Red wine increases the expression of human endothelial nitric oxide synthase. *J. Am. Coll. Cardiol.*, 41:471–8, 2003.
- Witztum, J. L., and Steinberg, D. The oxidative modification hypothesis of atherosclerosis: Does it hold for humans? *Trends Cardiovasc. Med.*, 11:93–102, 2001.
- Yokoi, H., Daida, H., Kuwabara, Y. et al. Effectiveness of antioxidant in preventing restenosis after percutaneous transluminal coronary angioplasty: The Probuccol Angioplasty Restenosis Trial. *J. Am. Coll. Cardiol.*, 30:855, 1997.
- Zitron, E., Scholz, E., Owen, R. W. et al. QTc prolongation by grapefruit juice and its potential pharmacological basis: HERG channel blockade by flavonoids. *Circulation*, 111:835–838, 2005.

Antiphospholipid Antibody Syndrome

- I. Diagnosis
- II. Management

GLOSSARY

anticoagulation to decrease the tendency of the blood to form a clot, thrombosis.

lupus short for systemic lupus erythematosus (SLE).

platelets very small disk-like particles that circulate in the blood alongside red and white blood cells initiating the formation of blood clots; platelets clump and form little plugs, thus causing bleeding to stop.

thrombocytopenia a mild decrease in platelet counts.

The principal autoantigen of antiphospholipid antibody syndrome has been shown to be beta-2-glycoprotein 1 (apolipoprotein H), a protein that binds cardiolipin and exposes an antigenic epitope. The antibody is called cardiolipin, lupus anticoagulant, or anti-beta-2 glycoprotein 1 depending on the test used. Two inexpensive tests, a standardized enzyme-linked immunosorbent assay for anticardiolipin antibodies and a clotting test for lupus anticoagulant, rapidly rule out antiphospholipid syndrome.

The antiphospholipid syndrome and factor V Leiden are the most common causes of thrombophilia accounting for greater than 20% of cases of recurrent thrombosis in individuals under age 40. Approximately 15% of women with recurrent pregnancy loss have this syndrome.

I. DIAGNOSIS

This complex syndrome actually is described as primary (not associated with another illness) and secondary (associated with SLE or another rheumatic disease). The antiphospholipid antibody (APLA) is detected in more than one-third of patients with lupus.

This syndrome is defined as the presence of either APLA or a lupus anticoagulant accompanied by this list of clinical manifestations:

1. Recurrent thrombosis of veins or arteries that are unexplained, that is, the usual causes of thrombosis such as immobilization or postsurgical are lacking
2. Frequent second- or third-trimester miscarriages
3. Thrombocytopenia and livedo reticularis commonly occur; patients with SLE commonly show positive blood serology for APLA, but the majority of these patients do not show clinical manifestations of the syndrome
4. Heart valves may become involved with thrombotic masses that may embolize and cause stroke
5. Ulcers of the lower legs around the ankle may resemble ulcers caused by obstruction to the venous system and stasis ulcers, but ulcers caused by this syndrome are exquisitely painful and may resemble pyoderma gangrenosum

II. MANAGEMENT

Thrombosis of veins or arteries should be treated with full-dose oral anticoagulation with warfarin. A Canadian study indicated that using warfarin to keep the target INR at 2–3 provides beneficial results that are equal to that observed with high-dose anticoagulation with an International Normalized Ratio (INR) of 3.1–4.0. A retrospective study in women in whom antiphospholipid antibody syndrome was diagnosed because of pregnancy loss (none of whom had a previous thrombotic event) suggests that treatment with low-dose aspirin provides protection from thrombosis. An ongoing clinical trial in the United States is comparing aspirin with placebo and a study in the UK is comparing aspirin with low-dose warfarin plus aspirin.

Fortunately, this syndrome is rare. Individuals who have lupus and other autoimmune diseases may test positive for the antiphospholipid antibody syndrome, but the majority usually do not manifest the symptoms, signs, and complications outlined above.

BIBLIOGRAPHY

- Lockshin, M. D., and Erkan, D. Treatment of the antiphospholipid syndrome. *N. Engl. J. Med.*, 349:1177–79, 2003.

Antiplatelet Agents

- I. Mechanism of Action
- II. Indications
- III. Available Antiplatelet Agents

veins. Antiplatelet agents are used in virtually all patients with coronary artery disease to manage the acute and chronic phases of the disease as well as its complications.

GLOSSARY

acute coronary syndrome this syndrome defines patients with acute chest pain caused by myocardial infarction or unstable angina.

aggregation platelet clumping.

angina chest pain caused by temporary lack of blood to an area of heart muscle cells, usually caused by severe obstruction of the artery supplying blood to the segment of cells.

arrhythmia general term for an irregularity or rapidity of the heartbeat, an abnormal heart rhythm.

atherosclerosis same as atheroma; raised plaques filled with cholesterol, calcium, and other substances on the inner wall of arteries that obstruct the lumen and flow of blood; the plaque of atheroma hardens the artery, hence the term atherosclerosis (sclerosis = hardening).

myocardial infarction death of an area of heart muscle due to blockage of a coronary artery by blood clot and atheroma, medical term for heart attack or coronary thrombosis.

PCI percutaneous coronary intervention; percutaneous transluminal coronary angioplasty (PTCA), often involving the use of intracoronary stents.

platelets very small disk-like particles that circulate in the blood alongside red and white blood cells initiating the formation of blood clots; platelets clump and form little plugs called platelet aggregation, thus causing bleeding to stop.

thrombi blood clots.

ASPIRIN WAS THE ONLY ANTIPLATELET AGENT available from the 1970s to the 1980s. Today we now have more than five agents available. These cardioactive drugs are useful in the prevention of thrombi in coronary arteries and those arteries that supply the brain, but they are much less effective in preventing thrombi that occur in

I. MECHANISM OF ACTION

Coronary thrombosis is known to be the major cause of coronary artery occlusion resulting in fatal or nonfatal acute myocardial infarction. Antiplatelet agents are named this because they inhibit platelet aggregation, which plays a major role in coronary thrombosis, myocardial infarction, and cardiac death.

Platelets clump on to atherosclerotic plaques, causing occlusion of the artery, and/or embolize downstream. The occlusion of these vessels may induce fatal arrhythmias and cardiac death. In patients with unstable angina, angiography has confirmed the presence of platelet clumps attached to the surface of eccentric atheromatous plaques that jut into the lumen of arteries causing partial to near complete occlusion. The atheromatous plaques may become fissured or rupture exposing a “porridge/gruel” like substance or substances that are highly thrombogenic. (See also the chapter Atherosclerosis/Atherothrombosis.) However, antiplatelet agents are not expected to prevent all forms of thrombotic events.

After plaque rupture the formation of a platelet-rich thrombus requires three essential steps:

1. Platelet adhesion: This occurs shortly after an atheromatous plaque has ruptured and the process of adhesion is mediated by the platelet glycoprotein IIb receptor through its interaction with von Willebrand factor.
2. Platelet activation: The smooth discoid platelet assumes a spiculated form, thus increasing the surface area of the platelet membrane where thrombin is generated. Figure 1 illustrates the complex and orchestrated processes that lead to platelet aggregation along with stimulatory and inhibitory drugs and substances.

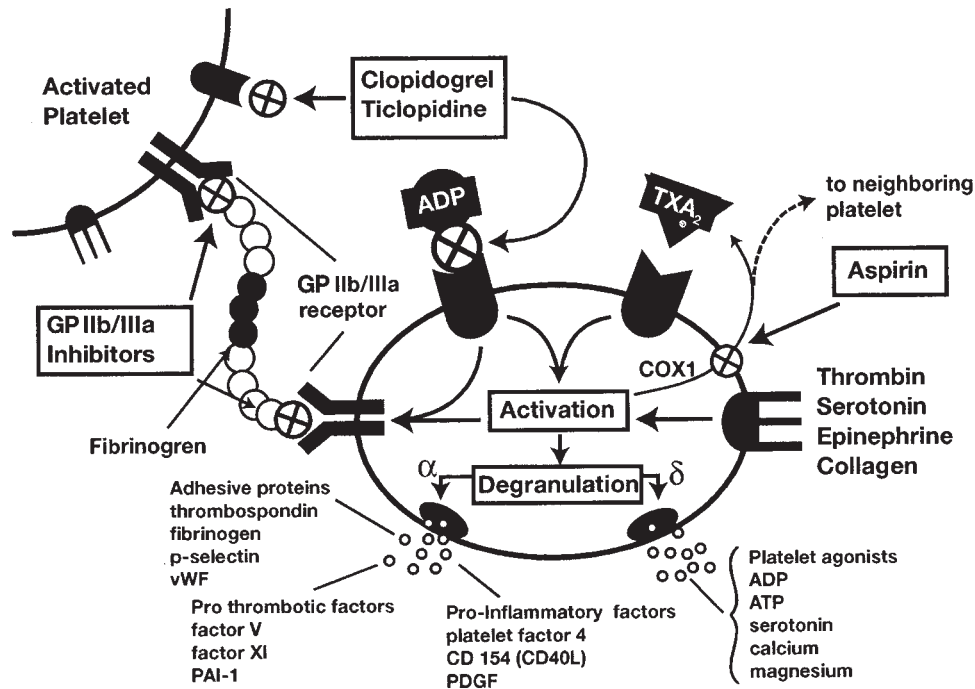

FIGURE 1 Platelet activation is an important early step in the pathophysiology of atherothrombosis. Platelet activation involves: (1) a shape change in which the platelet membrane surface area is greatly increased; (2) the secretion of pro-inflammatory, prothrombotic, adhesive, and chemotactic mediators (release reaction), that propagate, amplify, and sustain the atherothrombotic process; and (3) the activation of the glycoprotein (GP) IIb/IIIa receptor from its inactive form. Multiple agonists including thromboxane A₂ (TXA₂), adenosine diphosphate (ADP), thrombin, serotonin, epinephrine, and collagen, can activate the platelet and thus contribute toward establishing the environmental condition necessary for atherothrombosis to occur. Aspirin inhibits the production of thromboxane A₂ by its effect on the enzyme cyclooxygenase (COX) 1. The ADP receptor antagonists clopidogrel and ticlopidine prevent the binding of ADP to its receptor. The effect of combining aspirin and clopidogrel is synergistic in preventing platelet aggregation. Antithrombins such as unfractionated or low-molecular-weight heparin, hirudin, or bivalirudin are important in interfering with both thrombin-induced platelet activation and coagulation. The GP IIb/IIIa receptor antagonists act at a later step in the process by preventing fibrinogen mediated cross-linking of platelets, which have already become activated. ATP = adenosine triphosphate; PAI = plasminogen activator inhibitor; PDGF = platelet-derived growth factor; vWF = von Willebrand factor. (From Mehta, S.R., and Dphil, S.Y. (2003). Short- and long-term oral antiplatelet therapy in acute coronary syndromes and percutaneous coronary intervention, *J. Am. Coll. Cardiol.*, 41(4), 80S. With permission, American College of Cardiology Foundation.

3. Platelet aggregation: Platelet activation converts the glycoprotein IIb/IIIa receptor into a form that can bind fibrinogen and aggregation occurs.

dipyridamole plus aspirin, and platelet glycoprotein IIb/IIIa receptor blockers.

II. INDICATIONS

Antiplatelet agents are of proven value in the management of non-ST segment elevation myocardial infarction; stable and unstable angina; post coronary artery bypass graft (CABG), coronary artery stents, cerebral transient ischemic attacks (TIAs); and lone atrial fibrillation in individuals younger than 65.

III. AVAILABLE ANTIPLATELET AGENTS

Currently used antiplatelet agents include aspirin, clopidogrel (ticlopidine still has a role, see Section III.B),

A. Aspirin

Acetylsalicylic acid irreversibly acetylates the enzyme cyclooxygenase. This enzyme is necessary for the conversion of platelet arachidonic acid to thromboxane A₂, a powerful platelet-aggregating agent. Cyclooxygenase is inhibited by all nonsteroidal anti-inflammatory drugs (NSAIDs), aspirin transfers the acetyl group to the enzyme that is irreversibly inactivated. Other NSAIDs such as ibuprofen act as reversible inhibitors of cyclooxygenase (see the chapter Nonsteroidal Anti-Inflammatory Drugs).

Table 1 gives the clinically useful indications for aspirin. Most important, both the use of aspirin and the administration of nitroglycerin sublingually also contribute to

TABLE I
Indications for Aspirin

Cardiovascular	Comment
1. Unstable angina	Proven
2. Stable angina	Proven
3. Acute-onset myocardial infarction	Proven, also enhances effect of thrombolytic agents
4. Post-MI	Proven effective
5. Silent ischemia	Strongly advisable
6. Coronary artery bypass surgery	May prevent graft occlusion
7. Post-coronary angioplasty	Modest decrease in reocclusion
8. Lone atrial fibrillation	As good as oral anticoagulants
9. Bioprosthetic valves	In combination with dipyridamole
10. Transient cerebral ischemic attacks	Proven in both men and women
11. Post-nonhemorrhagic strokes	
12. Patients over age 40 years at risk	Strongly advisable
13. Diabetics at high risk for CHD	Advisable

CHD, coronary heart disease; MI, myocardial infarction.

the prevention of fatal and nonfatal heart attacks. It is important for individuals to realize that a rapid-acting aspirin formulation such as two 80- to 81-mg chewable aspirins taken soon after the onset of chest pain has been shown to cause a 25% reduction in fatal and nonfatal myocardial infarction, whereas nitroglycerin has no effect on prevention. Nitroglycerin ameliorates the pain of stable, mild angina and its use has been overvalued.

A recent study by Gum et al. demonstrated the natural history of aspirin resistance and documented a greater than threefold increase in the risk of major adverse events associated with aspirin resistance. Fortunately this form of resistance is rare and occurred in less than 5% of the 326 stable cardiovascular patients administered aspirin.

B. Clopidogrel

Clopidogrel is a thienopyridine derivative and an analog of ticlopidine; the drug inhibits platelet aggregation by inhibiting adenosine diphosphate (ADP) induced platelet activation and inhibits platelet fibrinogen binding. Clopidogrel is more effective than ticlopidine, but is considerably less toxic. Clopidogrel prevents platelet degranulation and the release reaction which produces prothrombotic substances. This drug selectively and irreversibly prevents ADP from binding to the platelet ADP receptor and inhibits the transformation of the

glycoprotein IIb/IIIa receptor to the form that binds fibrinogen and links platelets. Clinical studies confirm the drug's effectiveness.

1. CAPRIE Study

In the Clopidogrel versus Aspirin in Patients at Risk for Ischemic Events (CAPRIE) study, the control was marginally better than aspirin ($p = 0.045$). Clopidogrel is recommended when aspirin is not tolerated.

2. CURE Trial

The Clopidogrel in Unstable Angina Recurrent Events (CURE) trial was a double-blind placebo-controlled randomized trial with clopidogrel versus placebo in addition to aspirin and other optimal therapy for patients with unstable angina and non-ST elevation acute myocardial infarction (MI). Of the 12,652 patients, 16.5% (2072) had CABG surgery and 21% (2662) had percutaneous coronary intervention (PCI). At follow up 12 months later clopidogrel treatment caused a 20% relative risk reduction in the outcome of MI, stroke, or cardiovascular death ($p = 0.00009$). Significant bleeding occurred in the clopidogrel group compared with the placebo group (3.7% vs. 2.7%; $p = 0.001$), but there was no significant increase in life-threatening bleeding: 135 bleeds (2.2%) for clopidogrel and 112 bleeds (1.8%) for the placebo group ($p = 0.13$). The major risk of bleeding with clopidogrel has been noted in patients with acute coronary syndromes scheduled for immediate CABG. In the CURE study most patients undergoing bypass surgery had the study drug stopped for a short period of time (days before surgery).

3. PCI CURE

The PCI CURE study was a prospectively planned sub-study of CURE. The study was confined to the 2658 patients who underwent PCI and randomized to clopidogrel and aspirin versus just aspirin. At 30 days there was a significant benefit of clopidogrel over placebo. Most important, the benefit of clopidogrel appeared identical regardless of whether patients received PCI on an emergency basis or days after discharge.

4. CREDO Trial

This trial randomized 2116 patients. Clopidogrel 300 mg or 600 mg plus aspirin was administered from 3 to 24 h

before PCI. At one year patients who received clopidogrel plus aspirin greater than 6 h before PCI caused a 26.9% reduction in the risk of death, MI, or stroke ($p=0.02$). Clopidogrel, 600-mg loading dose given 12–24 h (at least 6 h) prior to PCI and stenting is a recommended regimen. In this regard, clopidogrel has largely replaced ticlopidine.

Because of the major risk for bleeding with glycoprotein receptor blockers, clopidogrel and aspirin combination therapy should be the preferred therapy for patients with high-risk unstable angina or non-ST elevation acute MI undergoing PCI. The combination is particularly advisable when intracoronary stents are used. Because of the major risk for bleeding with glycoprotein receptor blockers, clopidogrel and aspirin combination therapy should be the preferred therapy for patients with high-risk unstable angina or non-ST elevation acute MI except in patients undergoing urgent CABG. Intermediate- and low-risk patients not due to receive urgent PCI and in whom further tests are necessary and when PCI is deferred days to months after the acute event appear to be best treated with the clopidogrel and aspirin combination instead of platelet receptor blockers. In patients scheduled for urgent CABG, clopidogrel should be withheld to avoid bleeding.

5. Clopidogrel versus Ticlopidine

Because ticlopidine causes leukopenia and rarely agranulocytosis, it has been replaced by clopidogrel. A recent randomized clinical trial, however, indicates superiority of ticlopidine over clopidogrel after placement of coronary artery stents. In a study by Muller et al. in 700 patients with 899 lesions, cardiovascular death occurred in 8 patients administered ticlopidine versus 26 patients with clopidogrel ($p=0.003$). The combined end point of cardiovascular death or nonfatal MI occurred in 19 patients receiving ticlopidine versus 40 patients administered clopidogrel ($p=0.005$); after adjustment for covariables, ticlopidine reduced the risk of death by 63% compared with clopidogrel.

Most important, clopidogrel will be a frequently used cardioactive agent worldwide in patients undergoing PCI. Unfortunately, clopidogrel activation requires the CYP450 3A4 system; antiplatelet activity of the drug is substantially inhibited by statins metabolized in the liver by the cytochrome pathway. These statins include the commonly used atorvastatin, simvastatin, and fluvastatin. Pravastatin and rosuvastatin are excreted by the renal system and do not interact. Inhibitory effects have not been reported for ticlopidine. The high use of hepatic

metabolized statins in this study may explain the superiority of ticlopidine over clopidogrel.

C. Platelet Glycoprotein IIb/IIIa Receptor Blockers

There are approximately 75,000 glycoprotein IIb/IIIa receptors on the surface of each platelet. Antagonism of these receptors blocks the final common pathway for platelet aggregation — the binding of fibrinogen to the platelet glycoprotein receptors; platelet aggregation caused by thrombin, thromboxane A₂, ADP, collagen, and shear-induced platelet aggregation is prevented. Unfortunately, these agents do not affect platelet activation and degranulation, unlike ADP receptor antagonists which are active at much earlier stages of the atherothrombotic cascade.

1. Abciximab (ReoPro)

This widely used platelet receptor blocker inhibits both alpha IIb3 receptor and alpha v beta 3 receptors. Several randomized clinical trials have documented the beneficial effects when used for patients undergoing urgent PCI. This drug is not recommended for patients who are not scheduled for urgent PCI. Dosage would include 0.25 mg/kg IV bolus over at least 1 minute, immediately followed by IV infusion of 0.125 µgram/kg/minute for 18–24 h, concluding 1 h after PCI.

2. Eptifibatid (Integrilin)

This platelet receptor blocker has actions that are similar to abciximab. In a randomized clinical trial (PURSUIT), a significant benefit was observed in patients who underwent PCI within 72 h with no benefit at 30 days in those without PCI. In another large trial (TACTICS), eptifibatid was beneficial only in patients with acute coronary syndromes treated with early invasive PCI. In another trial (TARGET), the drug caused less protection from major ischemic events than abciximab. In the trial PRISM-PLUS, eptifibatid reduced events at seven days but not at six months. Dosage would be IV bolus of 135 µgram/kg followed by an infusion of 0.5 µgram/kg/minute for a further 20–24 h after PCI.

3. Tirofiban (Aggrastat)

This platelet receptor blocker shows specificity toward alpha IIb3 receptor and has a shorter biological half-life

than abciximab and eptifibatide. Tirofiban and eptifibatide are indicated only in patients in whom immediate PCI is not planned. In this population of patients the combination of clopidogrel and aspirin may prove to be more efficacious at 30 days and 1 year follow up. A meta-analysis of randomized clinical trials with these three agents with the exception of abciximab used as indicated for PCI planned within 24 h indicates that nondiabetic patients had no survival benefit.

In a large randomized trial (TACTICS) patients were treated with tirofiban for 48 h plus aspirin and heparin and randomized to either invasive therapy (coronary angiography and revascularization) or conservative strategy. It is claimed that at 6 months there was a significant reduction in death or MI ($p=0.0498$; $p=0.05$) This $p=0.05$ is hardly the level of significance required to recommend a treatment strategy to the population at large. In clinical medicine it is essential to achieve a significance level of $p < 0.02$ to be meaningful in terms of saving lives.

4. Oral Agents

Several randomized clinical trials have shown no benefit with oral agents that included orbofiban (in the OPUS trial), sibrafiban (in SMPHONY, and xemilofiban (in the EXCITE trial) caused excess mortality, usually sudden death, and approximately a 30% increase in mortality.

In five large randomized trials oral platelet receptor blockers showed a consistency toward increased mortality when compared with placebo. A 37% increase in mortality was observed in a meta-analysis of four large trials. Thirty days after commencement of one trial there was a 40% higher incidence of MI associated with these agents. Except for the proven beneficial defects of abciximab for patients undergoing primary PCI, the IV agents, also have not been a major success in terms of causing significant improvement in survival at 6 months, and they cause a significantly high excess in the incidence of major bleeding. The partial effectiveness of oral and IV agents may relate to the fact that they do not affect platelet activation and

degranulation; processes that occur very early in the stage of the platelet thrombotic process.

Several randomized clinical trials in progress should indicate which platelet receptor blocker is best for acute clinical situations and the role for clopidogrel combined with aspirin in patients stratified to receive PCI versus conservative therapy.

BIBLIOGRAPHY

- Cannon, C. Small molecule glycoprotein IIb/IIIa receptor inhibitors as upstream therapy in acute coronary syndromes. Insights from the TACTICS TIMI-18 Trial. *J. Am. Coll. Cardiol.*, 41:43–48S, 2003.
- Gum, P. A., Kottke-Marchant, K., Welsh, P. A. et al. A prospective, blinded determination of the natural history of aspirin resistance among stable patients with cardiovascular disease. *J. Am. Coll. Cardiol.*, 41:961–5, 2003.
- Hans-Christoph, D., Bogousslavsky, J., Brass, L. M. et al. On behalf of the MATCH investigators: Aspirin and clopidogrel compared with clopidogrel alone after recent ischaemic stroke or transient ischaemic attack in high-risk patients (MATCH): Randomised, double-blind, placebo-controlled trial. *Lancet*, 364: 331–3, 200.
- Lange, R. A., and Hillis, L. D. Antiplatelet therapy for ischemic heart disease. *N. Engl. J. Med.*, 350:27–80, 2003.
- Khan, M. Gabriel. *Cardiac Drug Therapy*, sixth edition, W. B. Saunders, Philadelphia, 423, 2003.
- Mehta, S. R., and Yusuf, F. Short and long-term oral antiplatelet therapy in acute coronary syndromes and percutaneous coronary intervention. *J. Am. Coll. Cardiol.*, 41:79–88S, 2003.
- Moliterno, D. J., and Chan, A. W. Glycoprotein IIb/IIIa inhibition in early intent-to-stent treatment of acute coronary syndromes: EPIS-TENT, ADMIRAL, CADILLAC, and TARGET. *J. Am. Coll. Cardiol.*, 41:49–54S, 2003.
- Mueller, C., Roskamm, H., Neumann, F.-J. et al. A randomized comparison of clopidogrel and aspirin versus ticlopidine and aspirin after the placement of coronary artery stents. *J. Am. Coll. Cardiol.*, 41:969–73, 2003.
- Schulman, S. P. et al. Antiplatelet therapy in non-ST-segment elevation acute coronary syndromes. *JAMA*, 292:1875–1882, 2004.
- Steinhubl, S. R., Berger, P. B., Mann, J. T. et al. Early and sustained dual oral antiplatelet therapy following percutaneous coronary intervention. A randomized controlled trial. *JAMA*, 288:2411–2420, 2002.
- SYMPHONY Investigators. A randomized comparison of sibrafiban, and oral platelet glycoprotein IIb/IIIa receptor antagonist, with aspirin for acute coronary syndromes. *Lancet*, 355:337, 2000.
- The CURE Investigators. Effects of Clopidogrel in addition to aspirin in patients with acute coronary syndromes without ST segment elevation. *N. Engl. J. Med.*, 345:494–502, 2001.

Arginine and the Heart

I. Clinical Study

GLOSSARY

angina chest pain caused by temporary lack of blood supply to an area of heart muscle cells, usually caused by severe obstruction of the artery supplying blood to the segment of cells.

brachial artery the artery of the arm and forearms that supplies blood to the upper limb including the hands.

endothelium the innermost part of the intima that comes in contact with circulating blood, a silky smooth layer of epithelial cells.

ischemia temporary lack of blood and oxygen to an area of cells, for example, the heart muscle, usually due to severe obstruction of the artery supplying blood to this area of cells.

I. CLINICAL STUDY

Study question: The many risk factors for coronary artery disease are associated with reduced production of nitric oxide (NO) by the endothelium. L-arginine supplementation appears to have modest clinical benefits in patients with angina. The effect of a medical food bar containing L-arginine, vitamin B₆, B₁₂, vitamin C, folic acid, and niacin was evaluated.

Methods: 36 patients with stable angina were randomized and had two treatment periods of 2 weeks' duration.

Each group received two active bars or placebo bars. The brachial flow-mediated dilatation of the brachial artery in the arm was measured by ultrasonography.

Results: The medical food bar improved flow-mediated vasodilatation, treadmill exercise time, and quality of life scores. However, electrocardiographic signs of ischemia or time to onset of angina were not changed.

Perspective: Two other studies, however, have shown no benefit to endothelial function and exercise performance in patients with coronary heart disease who were receiving medical management with statins and other agents. However, folic acid, vitamin B₆, B₁₂, vitamin C, and niacin may increase vascular NO activity and may have contributed here. Strategies that increase endothelial NO synthase activity and thus, endothelial NO bioactivity may lead to development of a new range of antianginal medications. These strategies include provision of cofactors for the enzyme NO synthase, enhancement of the transcription of the gene for this enzyme, and stabilization of messenger RNA (mRNA). Administration of the substrate L-arginine does not appear to be useful, but further studies are required.

BIBLIOGRAPHY

- Cannon, R. O. Oral L-arginine (and other active ingredients) for ischemic heart disease? *J. Am. Coll. Cardiol.*, 59:46–47, 2002.
- Maxwell, A. J., Zapien, M. P., Pearce, G. L. et al. Randomized trial of a medical food for the dietary management of chronic stable angina. *J. Am. Coll. Cardiol.*, 59:57–45, 2002.

Arrhythmias/Palpitations

- I. Origin of the Heartbeat
- II. Palpitations, Premature Beats, and Irregular Beats
- III. Tachycardia
- IV. Antiarrhythmic Agents
- V. Automatic Implantable Cardioverter Defibrillator
- VI. Conclusion

GLOSSARY

action potential voltage changes generated across the membrane of a nerve or muscle cells when the cell is activated through a variety of stimuli (electrical, chemical, or mechanical).

automaticity the ability to generate a spontaneous action potential.

cardiomyopathy heart muscle disease.

myocardial infarction death of an area of heart muscle due to blockage of a coronary artery by blood clot and atheroma; medical term for a heart attack or coronary thrombosis.

myocardium the heart muscle.

Purkinje fibers the terminal branches of the cardiac conducting system that run along the subendocardium.

ventricular fibrillation the heart muscle does not contract but quivers, therefore there is no heartbeat (cardiac arrest); no blood is pumped out of the heart and death occurs within minutes if the abnormal heart rhythm is not corrected.

I. ORIGIN OF THE HEARTBEAT

Arrhythmia is the term used for an irregularity or rapidity of the heartbeat or an abnormal heart rhythm. The patient experiences the sensation as stronger, more forceful, or rapid heartbeats, or skipping of beats; this sensation is commonly called palpitations. The sinus node, a very small group of specialized cells, is located in the upper right corner of the heart (see Fig. 1). The node is about 30×3 mm thick. Through its genetic code and the influx

and efflux of sodium and potassium into its cells, this natural pacemaker spontaneously fires infinitesimal electrical discharges that are conducted through electric cable-like bundles to the atria and ventricles causing the heart muscle to contract about 70 times a minute. The sinoatrial (SA) node's spontaneous depolarization and repolarization provides a unique and miraculous automatic pacemaker stimulus that activates the atria and atrioventricular (AV) node, which conducts the activation current down the bundle branches to activate the ventricular muscle mass. Cardiac cells outside the SA node normally do not exhibit spontaneous depolarization. The SA discharge rate, usually 50–100 beats per minute, is under autonomic, neural, chemical, and hormonal influence. The rate slows or gets faster depending on the needs of the body. The sinus node is like a powerful generator and has complete control of the heart rate.

Cells outside the sinus node pacemaker, for example, ventricular muscle cells, possess pacemaker activity that is so weak that the normal electrical discharge from the sinus node suppresses them. Myocardial cells normally lack the ability for either spontaneous formation or rapid conduction of the electrical impulse. For these functions most cardiac cells are dependent on cardiac pacemaker cells and the conduction system that consists of nodes, bundle branches, and a terminal branching network of specialized conducting tissue — the Purkinje fibers that ramify the myocardium. The sinus node undergoes spontaneous depolarization and has no resting phase; myocardial tissue must be depolarized and have a resting potential (see the chapter Electrocardiography). Occasionally, pacemaker cells outside the SA node may interrupt the normal heartbeat, causing a premature beat, which is also called an extra beat (see Fig. 1).

The electrical conducting system of the heart is vital to life. Damage to the electrical system can occur when the coronary arteries are blocked and fail to supply sufficient blood to the electrical system as may happen after several heart attacks. The electrical system can also be affected

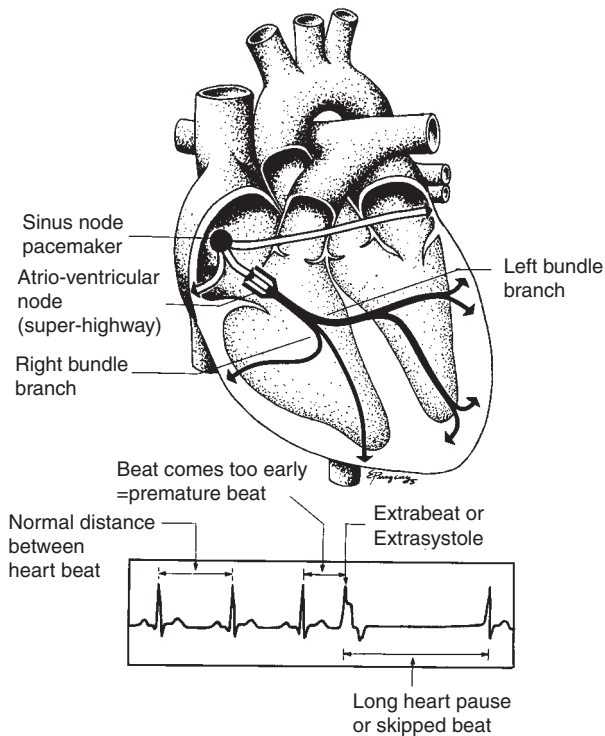

FIGURE 1 The electrical system of the heart. The electrocardiogram picks up the heart's electrical impulses transmitted through the skin of the chest. Premature beat is synonymous with terms extra beat, extrasystole, heart pause, or skipped beats. (From Khan, M. Gabriel, *Heart Trouble Encyclopedia*, Toronto: Stoddart, 1996.)

by certain degenerative diseases that cause calcification and hardening (sclerosis) of the bundles.

II. PALPITATIONS, PREMATURE BEATS, AND IRREGULAR BEATS

A. Definition

The word "palpitation" is used by doctors and by some patients to describe the heartbeat when it is fast, pounding, skipping, or irregular. A patient posed the following question:

I am 28 and have a problem with a heartbeat pause. This problem comes and goes and may result in 5–10 pauses each minute. Sometimes my heart feels as if it makes an extra beat. If I lie down, the irregularity seems more pronounced. I went to my family doctor who found nothing wrong. My doctor concluded that these pauses were caused by too much adrenaline in the blood. Could you tell me more about this: the possible causes, cures, and long-term harm to the heart?

The question is answered as follows:

A heartbeat pause is due to an extra beat (extrasystole), medically termed a premature beat (see Fig. 1). Premature beats may originate in the top chamber of the heart. These are referred to as atrial premature beats, and they are of no significance if they occur in a normal heart. If they occur in the ventricle, they are called ventricular premature beats. Patients perceive the abnormal heart rhythm as either an extra beat or a pause. An individual may state: "My heart skipped a beat." The extra heartbeat nearly always becomes more prominent when the heart slows while sitting or lying down. When the heart speeds up during walking or other activities, the extra beats are often suppressed by the normal beats. Movement of the body also prevents the sensation of the stronger heartbeat.

B. Causes

Premature beats may be due to either heart disease or extracardiac conditions, but often, they have no definable cause. Heart diseases that affect the heartbeat include disturbance of the blood supply to the heart due to coronary artery disease; diseases of the heart valves, usually due to prior rheumatic fever; and a common condition called mitral valve prolapse. Valve problems are easily excluded by a physician, who can hear murmurs or clicks when listening with the stethoscope. Echocardiography (cardiac ultrasound) can clarify the cause. Heart muscle diseases (cardiomyopathy) are fortunately rare. Alcohol abuse can also cause cardiomyopathy. Viruses that cause a flu-like illness can produce microscopic scars in the heart muscle (myocarditis) that may trigger extra beats. Myocarditis can be difficult to exclude if the patient is not seen during the acute phase.

Investigations of extra beats should include blood tests (to exclude anemia, a low serum potassium, or thyroid overactivity), chest x-ray, echocardiography, Holter monitor (24-h ECG recording), and a stress test.

Extracardiac precursors include alcohol, smoking, stimulants such as caffeine, amphetamines (diet pills), and nicotinic acid in megavitamins and several drugs. In susceptible individuals, disturbances of the heartbeat (arrhythmias) are more common 12–24 h after alcohol consumption. Other causes include thyroid overactivity and low oxygen in the blood due to lung diseases.

Premature or extra beats commonly occur in young individuals with normal hearts and cause no harmful effects. In the normal heart, they bear no relation to heart

attacks, sudden cardiac death, or heart failure, and they do not harm the heart.

Drug treatment is not indicated for patients with a normal heart because the side effects outweigh the benefits. Some patients, who are terribly bothered by numerous extra beats in the presence of a normal heart or mitral valve prolapse, respond to beta-blockers (see the chapter Beta-Blockers). Five to 15 pauses or premature beats per minute in a normal heart is of no significance and requires no drug treatment. Patients may have an extra beat that occurs after each normal heartbeat and more commonly after two normal beats. In the majority of individuals with premature beats, there is no good reason why they should occur at a particular time of the day or month. Several studies have utilized the 24-h Holter monitor to show that more than 66% of normal individuals studied have ventricular premature beats (VPBs). Unless serious heart disease is present, all the bumpings, flutterings, thumpings, and irregular beats can be ignored.

C. Diagnosis

I. Atrial Premature Beats

Premature beats that arise from the atrium are called atrial premature beats (APBs). An atrial premature P-wave has a morphology different from that of the sinus P-wave and is usually followed a QRS complex similar to that of the normally conducted sinus beat (see Fig. 2). Atrial premature beats may trigger atrial tachycardia or atrial fibrillation.

2. Ventricular Premature Beats

Premature beats that arise in the ventricle are called ventricular premature beats. These are bizarre looking beats with a wide QRS complex and an ST segment sloping off in a direction opposite to the abnormal QRS complex (see Fig. 3). There is no preceding P-wave and the extra beat is followed by a fully compensatory pause before the next normal sinus beat occurs. When this happens, the individual may feel that the heart has stopped for a second. A VPB following each normal beat (termed ventricular bigeminy) is a common occurrence in healthy individuals, but pairs (couplets) or runs of three beats (triplets, nonsustained ventricular) are not uncommon in those with heart disorders (see Figs. 3 and 4).

III. TACHYCARDIA

This is the term used by the medical profession to describe a fast heart rate of greater than 100 per minute. Tachycardias include:

1. Sinus tachycardia
2. Paroxysmal atrial tachycardia (PAT)
3. Atrioventricular nodal reentrant tachycardia (AVNRT)
4. Atrial fibrillation
5. Atrial flutter
6. Wolff-Parkinson-White syndrome (WPW)
7. Ventricular tachycardia

These tachycardias are usually differentiated for diagnostic purposes into narrow QRS and wide QRS and then into regular or irregular tachycardias (see Fig. 5).

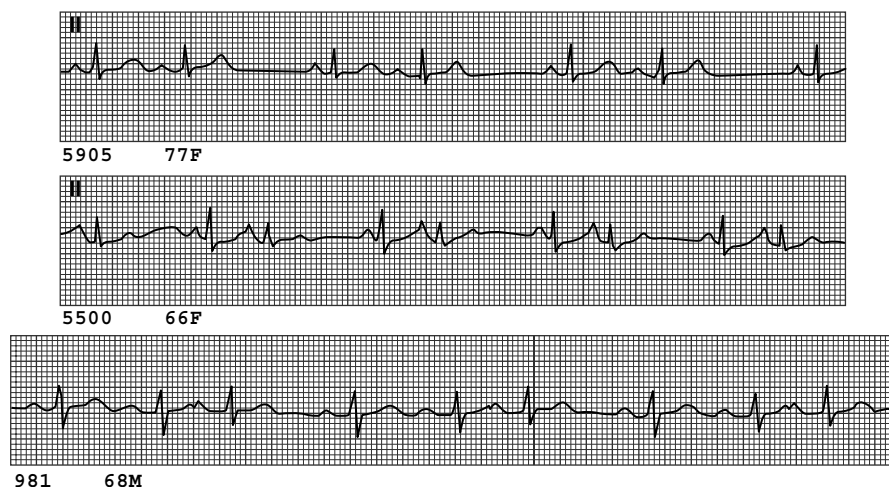

FIGURE 2 Premature atrial beats with bigeminal (A and B) and trigeminal (C) rhythm. B, the QRS complex of the premature atrial beats shows aberrant ventricular conduction (From Chou, T.C., (1996). *Electrocardiography in Clinical Practice*, 4th ed., Philadelphia: W.B. Saunders, p. 344.)

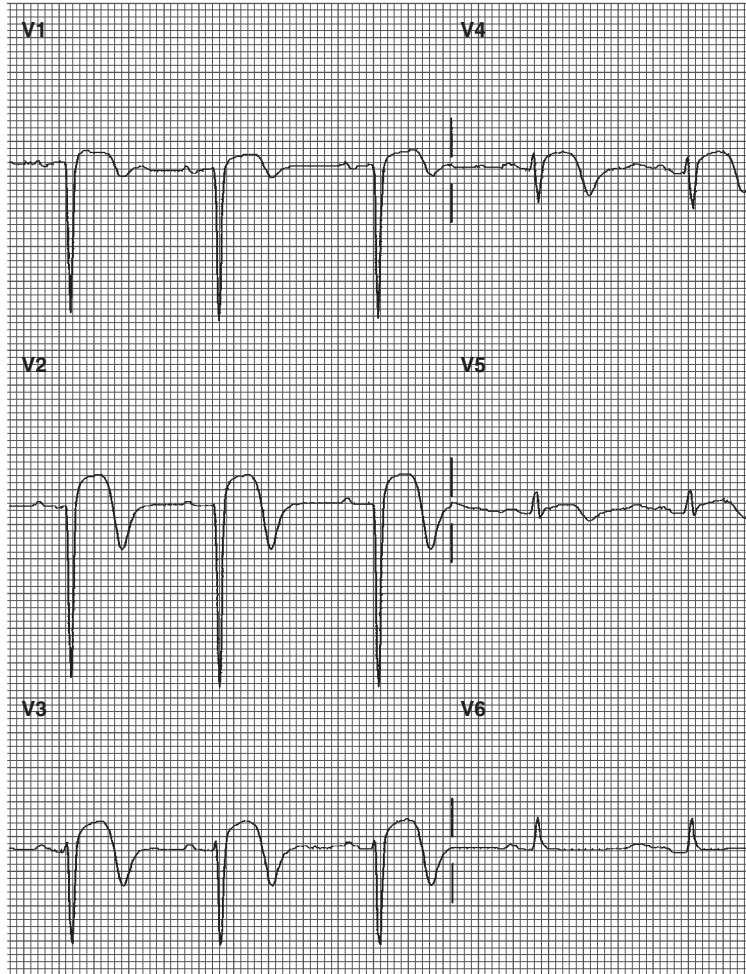

FIGURE 3 ST segment elevation in V₁ through V₅, poor R wave progression in V₂ through V₄ typical of recent anterior infarction.

A. Sinus Tachycardia

When the fast beat arises from the normal sinus node pacemaker, it is called a sinus tachycardia. This is a normal physiologic occurrence during exercise, infections causing fever, anxiety states, loss of blood, dehydration, and thyroid overactivity. This is one of the most common abnormal tachycardias occurring in young healthy adults.

B. Paroxysmal Atrial Tachycardia

Those who have episodes of very fast heart beat, usually 150–190 beats per minute, may have a condition known as PAT. If episodes are frequent, drug treatment may be necessary. The term paroxysmal atrial tachycardia was introduced more than 50 years ago and was formerly used to include AVNRT, but these two conditions have subtle differences. Most cases called PAT are truly AVNRT.

There is no conclusive evidence that excessive adrenaline triggers PAT.

In a few individuals, excessive adrenaline may play a role during stress or a heart attack. Excessive adrenaline is liberated in the heart muscle during a heart attack and increases the occurrence of premature beats and other abnormal heart rhythms. Pacemaker cells outside the sinus node commence an electrical discharge and take over the heart rhythm for up to a few hours. The ECG reveals a P-wave that precedes the QRS and its contour is different from the sinus P-wave; the rhythm may be regular or irregular. Some cases are caused by digoxin toxicity.

C. Atrioventricular Nodal Reentrant Tachycardia

The most common type of paroxysmal narrow regular tachycardia is one originating in the AV node; it is called

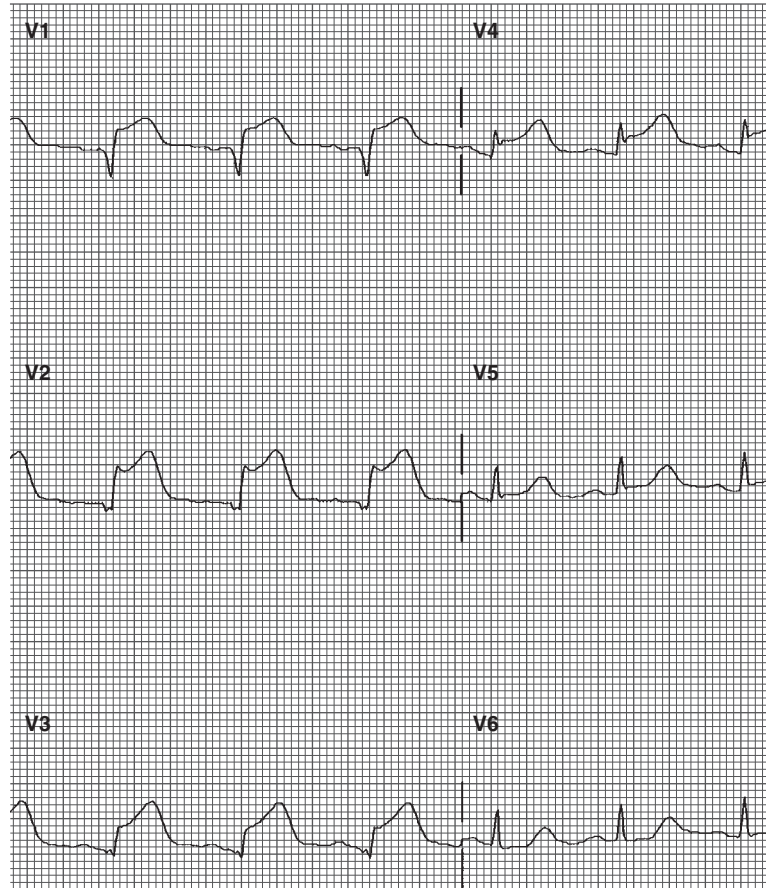

FIGURE 4 Sinus rhythm, rate 65. Run of ventricular premature complexes, abnormal ECG.

atrioventricular nodal reentrant tachycardia. There is no conclusive evidence that excessive adrenaline triggers this type of tachycardia. In a few individuals, excessive adrenaline may play a role during stress or during a heart attack. Excessive adrenaline is liberated in the heart muscle during a heart attack and increases the occurrence of premature beats and other abnormal heart rhythms. Beta-blockers can be useful when excessive adrenaline from stress or a heart attack precipitates tachycardias.

A typical history of a 76-year-old patient is described:

She can recall having PAT from age 22. Without warning, she would feel a sudden pounding of the heart. The beats were so rapid that it was difficult to count them. She would try certain maneuvers such as lying down, walking around, or taking a warm drink — all to no avail. Attacks would come on once or twice a year; in one year she had five episodes. The duration of the attacks was usually from several minutes to three or four hours. She was age 38 when she presented at the emergency room because this particular episode had

gone on for more than three hours. The episode stopped a few minutes after she came to the emergency room. She was informed that she had PAT, but she truly had AVNRT. Her attacks had a typical sudden onset with a rapid heart rate and abrupt cessation. Occasionally she felt dizzy, as if she was about to faint, but she never really lost consciousness. This form of tachycardia nearly always occurs in a normal heart, and this was the situation in this patient's case.

Additionally, in a normal heart AVNRT does not cause heart failure or angina, nor does it lead to a heart attack. At the time of her visit to the emergency room, the patient was being treated with quinidine and had nausea and diarrhea. The quinidine was discontinued and she was advised to suppress the attacks through the use of certain maneuvers that increase the activity of the vagus nerve; the vagus nerve slows the heart and keeps it in check.

Simple maneuvers to suppress AVNRT are (1) gagging by putting a finger at the back of the tongue to cause retching, (2) holding both nostrils tightly and breathing

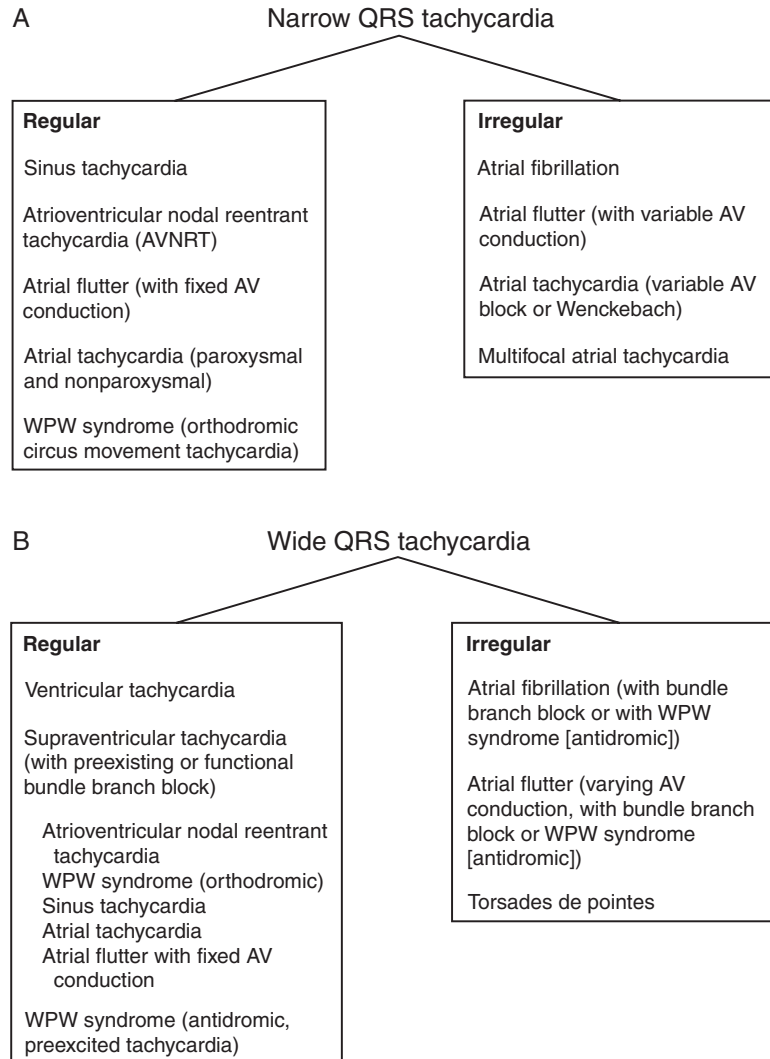

FIGURE 5 Method for rapid ECG interpretation. A, Step 11: The differential diagnosis of narrow QRS tachycardia. B, Step 11: The differential diagnosis of wide QRS tachycardia. (From Khan, M. Gabriel, (2005). *Heart Disease Diagnosis and Therapy*, second edition, New Jersey Humana Press.

out against the resistance for about 30 seconds, and (3) holding the breath and immersing the face in cold water for about 10 seconds. The patient was warned not to apply pressure on the eyeball because detachment of the retina may occur.

On a few occasions the attack was stopped in the emergency room by massaging her right carotid artery (carotid sinus massage) for 3–6 seconds. This stimulates the vagus nerve and suddenly stops the abnormal fast heart rhythm in more than 50% of individuals. This technique should not be tried until the patient is hooked up to a cardiac monitor or ECG. If these facilities are not available, someone needs to listen to the heartbeat while the doctor presses the carotid sinus. This technique is not used in individuals over age 60 or in those whose

carotid arteries are known to be obstructed by atheroma due to the rare possibility of stroke.

The above patient's attacks became more frequent after age 50. She was tried on digoxin, which was a 75% success for about two years. She later required a beta-blocker, which often helps in this situation. Very rarely a combination of digoxin and beta-blocker is necessary to suppress attacks, and this was tried with success for about two years. Finally, at age 51 she was tried on a beta-blocker alone and this was effective. At age 76, except for two or three one-hour episodes per year, her heart remained normal.

The majority of patients with AVNRT get immediate relief in the emergency room when given adenosine IV or IV verapamil. Verapamil cannot be used, however, in

individuals who have heart failure or who have a weak heart muscle, because it can precipitate heart failure in such cases. Adenosine, is as effective as verapamil, but safer. Intravenous adenosine corrects the condition within a few seconds. Adenosine 6 mg is given, but the drug has a short half-life of <5 seconds and a second bolus injection of 12 mg is sometimes required.

The ECG diagnosis of rapid tachycardia is simple. The heart rate is usually 150–200 beats per minute and P-waves are not visible in about 50% of cases because they are hidden within the QRS complex. In approximately 45% the P-waves are hidden, but on careful scrutiny they are visible at the end of the QRS complex in leads II, III, and AVF. In these leads, the P-waves cause a minor distortion of the tracing resulting in pseudo-S waves in these leads (see Fig. 6). If episodes are frequent, symptomatic, or bothersome effective therapy is achieved using radiofrequency catheter ablation of the circuit that promotes the arrhythmia. Electrophysiologic testing to identify high-risk patients who may benefit from ablation must be balanced against the 2% risk of a serious complication resulting from ablation.

D. Atrial Fibrillation

Atrial fibrillation is the most common persistent abnormal heart rhythm requiring treatment by doctors. The heart beats are completely irregular. The condition usually occurs after age 25, but occurs commonly after age 65 with a peak incidence after 75.

1. Causes

Atrial fibrillation can be due to previous rheumatic fever that damaged the valve leaving scars in the atria. The many conditions that trigger arrhythmia include hypertension, coronary artery disease, cardiomyopathy, congenital heart disease, and the many causes of heart failure. Any condition that causes hypertrophy or enlargement of the left atrium may trigger the arrhythmia. Also, this condition commonly occurs in a heart that is structurally normal; this is called lone atrial fibrillation. An extracardiac cause is thyrotoxicosis.

2. Characteristic Features

During atrial fibrillation the atrium beats extremely fast, about 400–500 times per minute; however, the impulses that arise from these beats, occurring outside the sinus

node, cannot all pass through the AV node. The AV node is like a superhighway that leads to the ventricle (see Fig. 1). At most, it can manage to carry 200–220 impulses. Therefore, 400 or more impulses cause a traffic jam and only a few impulses reach the ventricle in an erratic fashion. The ventricles therefore beat at 120–200 beats per minute, but very irregularly.

This condition is usually kept under control and patients' activities are not curtailed. If there is no serious underlying heart disease, the patient's life span can be normal. Atrial fibrillation is not to be confused with the dangerous ventricular fibrillation. In patients with heart disease, atrial fibrillation may precipitate heart failure. Most important, atrial fibrillation is a common cause of strokes. Therefore, anticoagulants are given to prevent strokes. This condition is usually treated with a beta-blocker or digoxin, which causes a jam in the AV node which acts as a tollgate at the entrance to the superhighway allowing less traffic to reach the ventricles. Instead of the ventricles beating at 120–200 per minute, they beat at 60–100 per minute (see the chapter Atrial Fibrillation).

E. Wolff-Parkinson-White Syndrome

Wolff-Parkinson-White (WPW) is a form of tachycardia that is similar to AVNRT but is less common. Individuals aged 15–40 may get severe tachycardia. In this condition, there is an extra electrical bundle called an accessory pathway or bypass tract, which runs from the atrium to the ventricle. Conduction of impulses occurs more quickly through this accessory or anomalous bundle, whereas normally the AV node tends to impede traffic and maintain a slow heart rate. The heart is otherwise structurally normal except on the rare association in the form of congenital heart disease or hypertrophic cardiomyopathy. WPW has a typical ECG appearance, and during attacks the heart rate may be as fast as 200–250 beats per minute (see Fig. 7). Special drugs are now available to treat this abnormal rhythm, and in some cases the accessory bundle may have to be divided by a nonsurgical radiofrequency ablation technique. Recent advances have made this procedure highly successful. Patients with WPW syndrome who experience hemodynamic instability during their arrhythmia are recommended catheter ablation as first-line therapy.

F. Ventricular Tachycardia

By definition, more than three VPBs occurring together constitute ventricular tachycardia. This is a serious

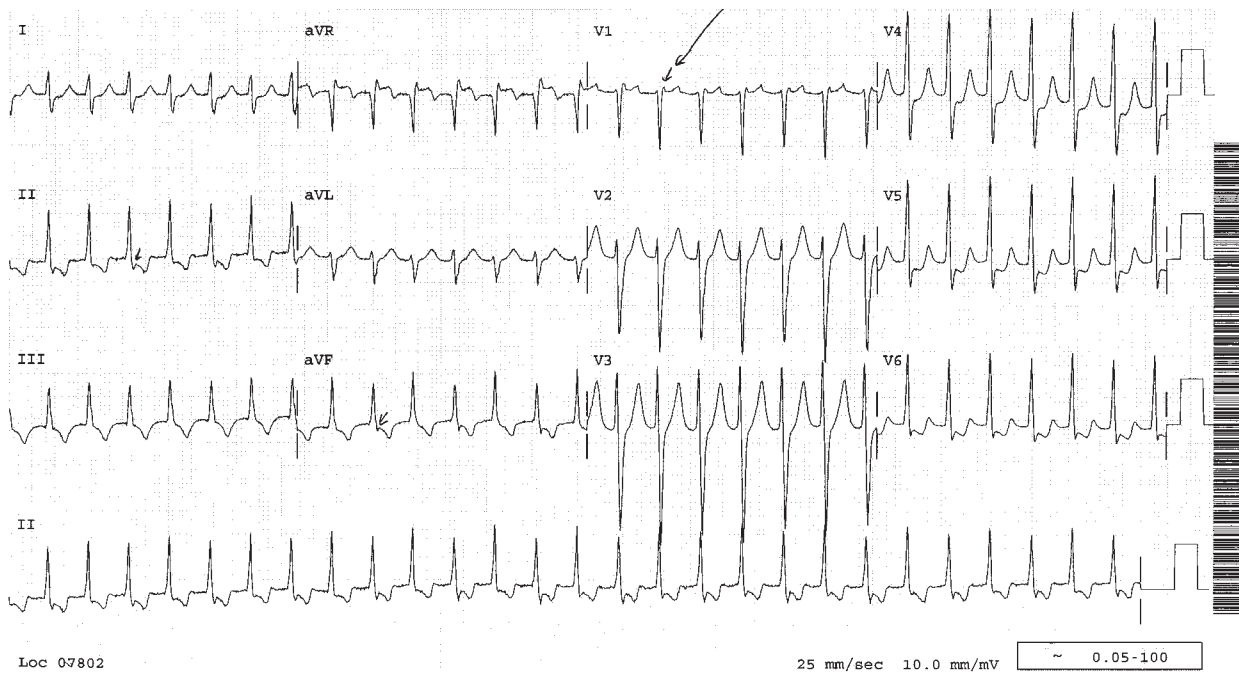

FIGURE 6A AV-nodal re-entrant tachycardia. Note the pseudo-s wave in lead III (arrow), and psuedo r' in V1 (arrow).

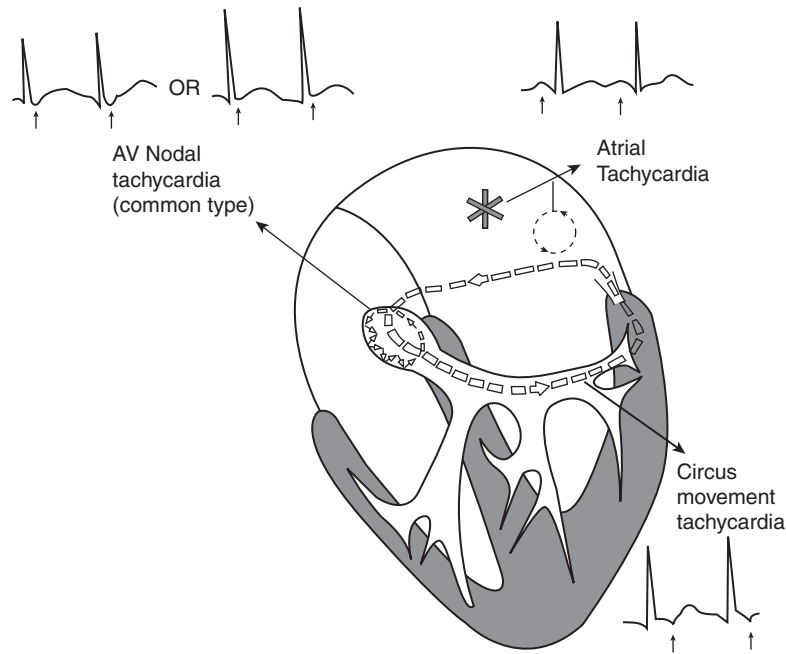

FIGURE 6B A representation of the sites of origin and mechanism of paroxysmal supraventricular tachycardia (SVT) as determined by the position and polarity of the P waves in relation to the QRS complexes. In atrial tachycardia the P wave precedes the QRS; its polarity in lead III depends on its location. In AV notdal reentry tachycardia the P wave is buried within the QRS or may distort the end of the QRS: that portion of the QRS is then negative in lead III. In circus movement tachycardia the P wave follows the QRS. (From Wellens, J.J.H., and Conover, M.B. (1992). *The ECG in Emergency Decision Making*. Philadelphia: W.B. Saunders, p. 75.)

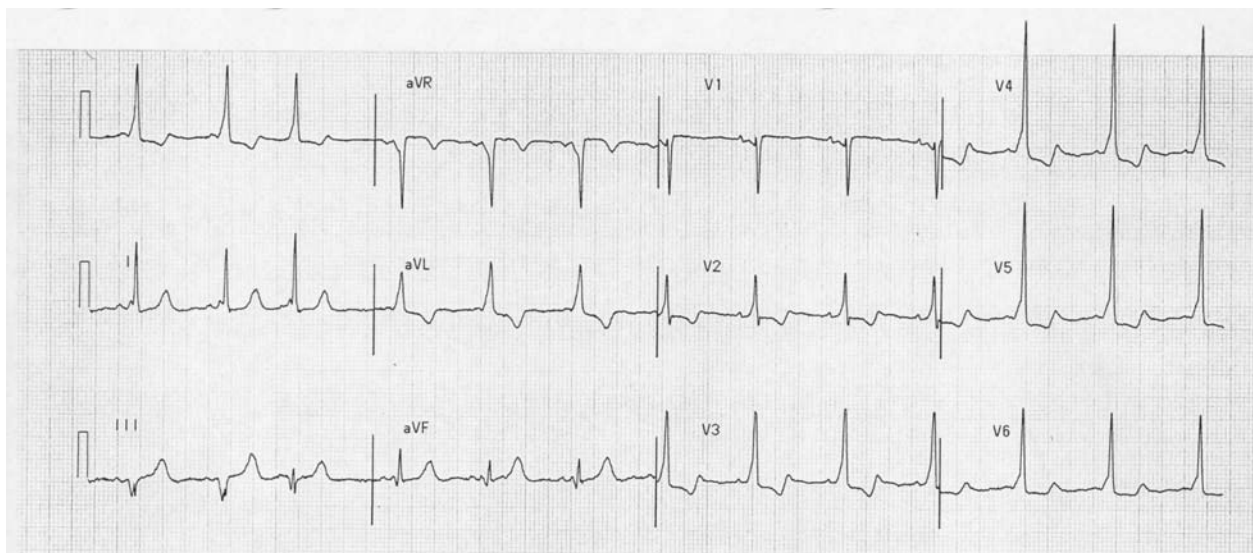

FIGURE 7 Sinus rhythm; supraventricular extrasystoles; WPW pattern; short PR and delta wave.

abnormal heart rhythm and occurs mainly in patients with severe coronary artery disease or severe cardiomyopathy. The heartbeat is regular but fast, between 120 and 200 per minute. Usually the diagnosis is made from an ECG that shows a wide QRS complex and regular tachycardia (see Figs. 8–10).

During a heart attack, ventricular tachycardia may occur and is usually treated with a drug called lidocaine followed by other drugs to suppress the rhythm. If success is not obtained, the patient's abnormal heart rhythm is converted to normal sinus rhythm with the use of a cardioverter, which delivers small electrical shocks to the heart. Such a cardioversion is carried out in the emergency room or the coronary care unit after the patient has been sedated. Frequent bothersome VPBs and nonsustained ventricular tachycardia are treated best with beta-blockers, and in some cases amiodarone may be necessary. Ventricular tachycardia may progress to ventricular fibrillation, which is usually the cause for sudden cardiac death. An implantable defibrillator may be necessary in some patients.

G. Torsades de Pointes

This is a pleomorphic form of ventricular tachycardia that usually occurs in the presence of a prolonged QT interval. The RR interval is irregular and the QRS complex shows a characteristic twisting of the points. The ventricular rate varies from 200–300 beats per minute and is usually not sustained for more than a minute. Longer episodes degenerate into ventricular fibrillation.

Drugs and conditions that may precipitate torsades de pointes include sotalol, amiodarone, and other antiarrhythmic agents; tricyclic antidepressants; antiviral and antifungal agents; antibiotics of the erythromycin-azithromycin series; hypokalemia and hypomagnesemia; insecticide poisoning; congenital long QT syndrome; cocaine abuse; and chloroquine and pentamidine.

IV. ANTIARRHYTHMIC AGENTS

Figure 11 illustrates how myocardial cells generate an action potential in phase zero through a fast influx of sodium ions into cells. This increases the resting potential and voltage of the cell (depolarization). During phase three the cell returns to its resting potential with an efflux of potassium ions. Some antiarrhythmic agents produce their effects by decreasing the rate at which sodium enters the myocardial cell during phase zero. Thus, generation of the action potential of an abnormal impulse is dampened and does not reach sufficient magnitude to produce abnormal beats. Quinidine, disopyramide, procainamide, flecainide, and propafenone decrease the rate at which sodium enters myocardial cells. Beta-adrenergic blocking agents, lidocaine, and several antiarrhythmic agents decrease the rate of automaticity of abnormal rhythms by depressing phase four of the action potential (as indicated by the arrow in Fig. 3). Amiodarone and a unique beta-blocker, sotalol, cause prolongation of the action potential (phase two) and retard the generation of an abnormal impulse. Most important, an increase in the absolute refractory

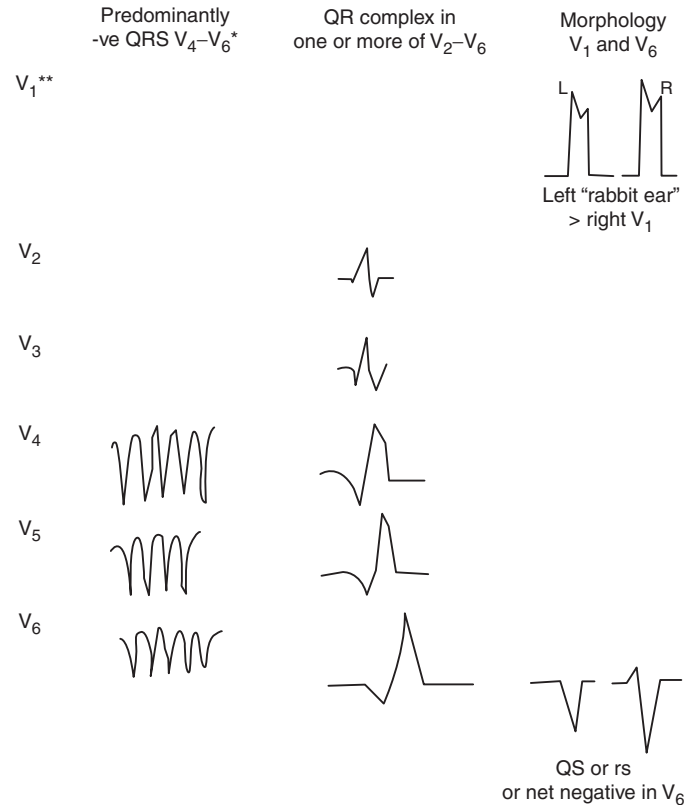

FIGURE 8 Electrocardiographic hallmarks of ventricular tachycardia (VT). * = or concordant negativity in leads V_1 through V_4 . Positive concordance in leads V_1 through V_6 can be caused by VT or Wolff-Parkinson-White antidromic (preexcited) tachycardia. ** = it is necessary to study the entire 12-lead tracing with particular emphasis on leads V_1 through V_6 ; lead II may be useful for assessment of P waves and AV dissociation. (From Khan, M. Gabriel (2001). *On Call Cardiology*, second edition. Philadelphia: W.B. Saunders, p. 141.)

period(phases one and two), protects the heart from dangerous impulse stimuli. During a 20–30 ms vulnerable period in phase three a strong electrical stimulus or ventricular ectopic beat can readily trigger ventricular tachycardia and ventricular fibrillation.

A. Digoxin (Lanoxin)

Digoxin is used to treat patients with atrial fibrillation to slow the fast heart rate. This drug may also be used to prevent recurrent attacks of AVNRT. It is used daily for a prolonged period to prevent recurrent attacks, but the success rate may be low for some patients. The important role of digoxin in slowing the heart rate in patients with atrial fibrillation is discussed in the chapter Atrial Fibrillation.

B. Beta-Blockers

Beta-blockers are occasionally used to treat AVNRT. These drugs can also be used to treat bothersome VPBs

when they are associated with increased secretion of catecholamines and in individuals with mitral valve prolapse. These agents have a beneficial effect on VPBs produced during or following a heart attack. Beta-blockers are the only safe antiarrhythmic drugs that have been proven to prevent sudden cardiac death and heart attacks.

Several other drugs are used to treat more difficult and serious heart rhythm disorders. Most of these drugs have serious side effects, are only 60–80% effective in controlling the disturbance, and do not prevent death. Thus, doctors are not keen to treat premature beats unless they are associated with serious heart disease. In such patients, when premature beats are numerous with runs of four or more occurring together for more than 30 seconds, drugs are usually tried.

C. Sotalol

Sotalol is unique in that it is the only beta-blocker that has class III antiarrhythmic effects. It is the most

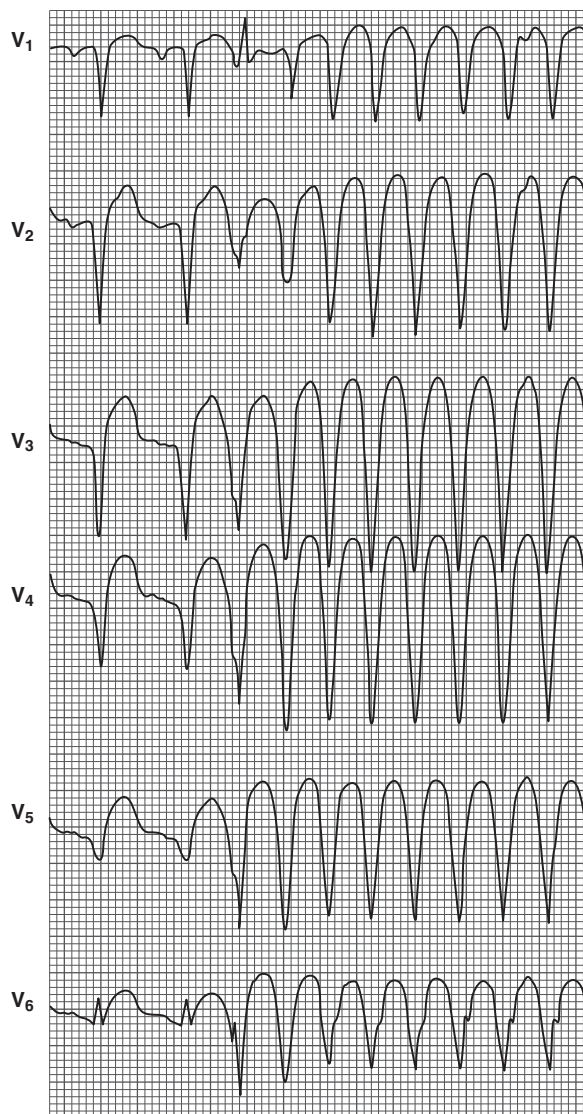

FIGURE 9 Onset of a tachycardia with negative precordial concordance. Negative precordial concordance indicates ventricular tachycardia, since such a pattern does not occur during anterograde conduction over an accessory pathway. (From Wellens, J.J.H., and Conover, M.B. (1992). *The ECG in Emergency Decision Making*. Philadelphia: W.B. Saunders, p. 60.)

effective beta-blocker available for the treatment of serious abnormal heart rhythms, particularly the prevention of ventricular tachycardia. This drug may prevent recurrences of paroxysmal atrial fibrillation, although this effect is modest.

Sotalol is hydrophilic and is eliminated by the kidney. The action of the drug is prolonged, so it is effective when taken once daily. It is not affected by smoking. The recommended dosage is 80 mg once or twice daily for 4 weeks, then 160 mg once daily with a maximum dose of 240 mg daily. The drug must not be used in patients with a low serum potassium, and it must not be used

concomitantly with drugs that increase the QT interval because torsades de pointes may be precipitated.

D. Amiodarone

This drug is effective in suppressing life-threatening abnormal heart rhythms and is approved for treating recurrent episodes of sustained ventricular tachycardia. The drug's major toxicity manifests deposits of granules in the cornea, fibrosis of the lung in about 5%, and grayish blue discoloration of the skin with prolonged

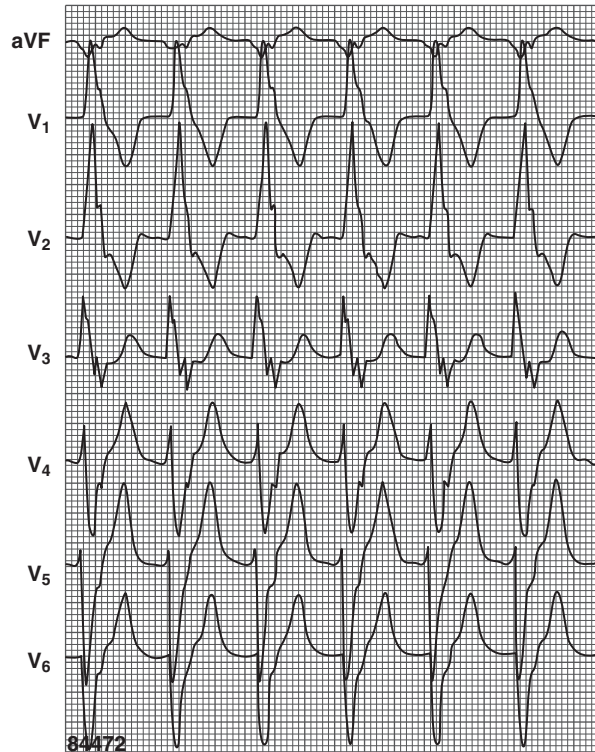

FIGURE 10 Ventricular tachycardia. Note the monophasic R wave in lead V₁ and the deep S in lead V₆, signs of ventricular tachycardia. The northwest axis is also a helpful clue. (From Wellens, J.J.H., and Conover, M.B. (1992). *The ECG in Emergency Decision Making*. Philadelphia: W.B. Saunders, p. 51.)

use at high doses. Neuropathy and thyroid disturbances may also occur. Amiodarone must not be used in combination with verapamil. Interaction may occur when used concomitantly with quinidine, digoxin, and oral anticoagulants such as warfarin. The drug should be avoided in patients with a low serum potassium and should not be used with agents that prolong the QT interval because torsades de pointes may be precipitated. It is also contraindicated in patients with sick sinus syndrome.

E. Disopyramide

This drug has effects similar to quinidine. It is useful in the emergency treatment of ventricular tachycardia when given intravenously. Disopyramide should not be used in patients with heart failure or poor heart muscle function because it can precipitate heart failure. It is contraindicated in individuals with glaucoma, kidney failure, low blood pressure, and enlargement of the prostate because urinary retention can be precipitated. The drug must not be used in combination with verapamil.

F. Lidocaine

This drug is used intravenously in emergency situations and is effective in suppressing ventricular tachycardia and serious premature beats (see the chapter Heart Attacks).

G. Mexiletine

This drug is more effective than disopyramide. It suppresses complex abnormal heart rhythms, but it has not improved survival rate. Mexiletine is contraindicated in patients with low blood pressure. The dose must be reduced if kidney failure is present. Side effects include slowing of the pulse, stomach problems, confusional states, double vision, and disturbance in walking (ataxia). The drug is therefore reserved for the treatment of life-threatening arrhythmias.

H. Procainamide

Procainamide has similarities to the well-known quinidine. It is of value when given intravenously in the emergency

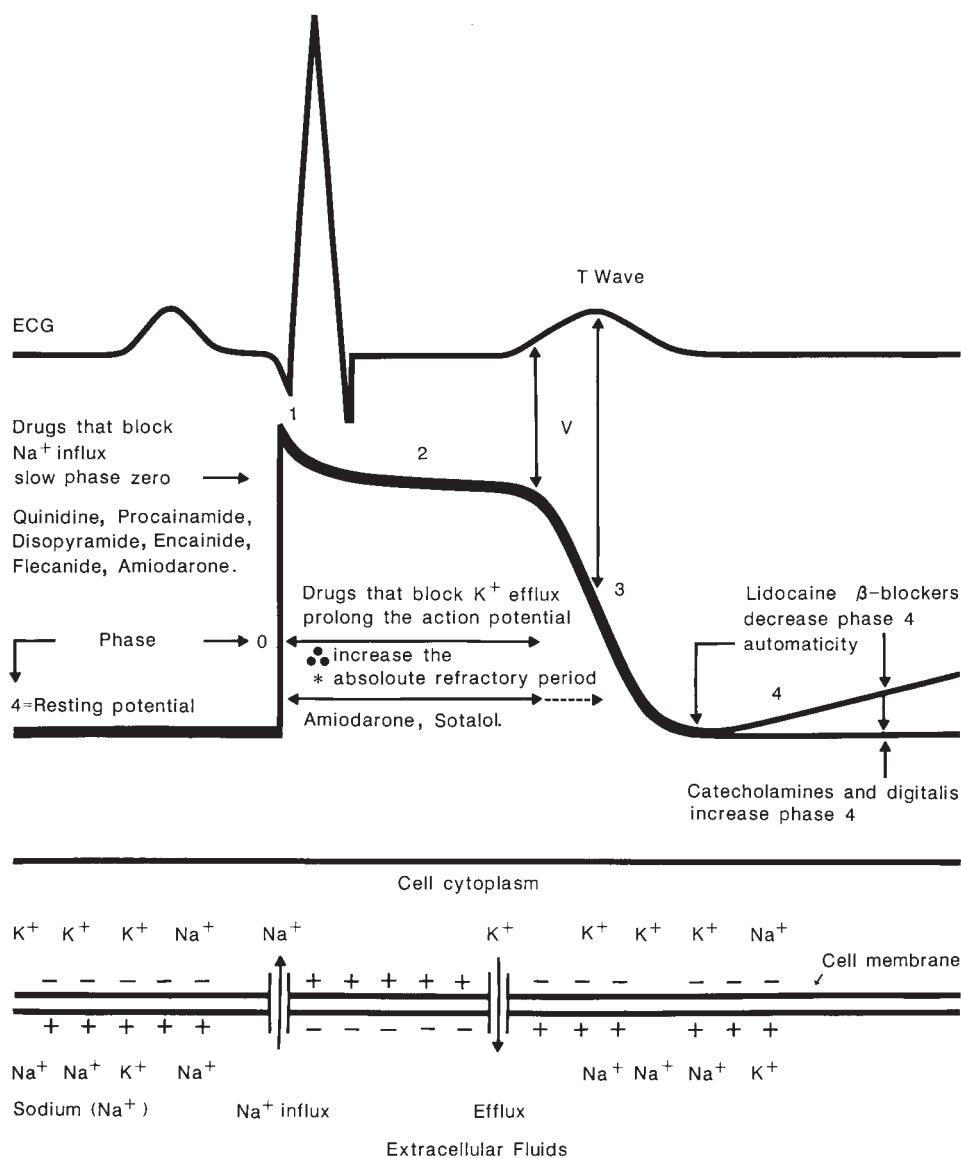

FIGURE II Antiarrhythmic drug action. (From Khan, M. Gabriel. Cardiovascular system pharmacology, *Encyclopedia of Human Biology*, second edition. San Diego: Academic Press, 1997.)

management of ventricular tachycardia that is not responsive to lidocaine. When used orally it has a variable effect. It is less effective than quinidine or disopyramide and when used for longer than six months, patients can develop joint pains and fever (lupus erythematosus). Although very rare, white blood cells can be damaged (agranulocytosis) with its use. The drug should not be used in patients with low blood pressure, severe heart failure, and myasthenia gravis.

I. Quinidine

The use of quinidine has greatly decreased since the advent of other antiarrhythmic agents. Quinidine suppresses premature beats in about 60% of cases, but it is only partially effective with life-threatening arrhythmias. Because of rare but serious side effects, the use of the drug is questionable. Quinidine can precipitate ventricular fibrillation, which is the most dangerous abnormal heart

rhythm, and cardiac arrest. It does not seem reasonable to give priority to a drug that may increase the risk of ventricular fibrillation and death. This agent increases the level of digoxin in the blood and when used concomitantly, care is necessary with digoxin and anticoagulants such as warfarin.

V. AUTOMATIC IMPLANTABLE CARDIOVERTER DEFIBRILLATOR

When life is severely threatened by the recurrence of abnormal heart rhythms that have caused cardiac arrest or recurrent sustained ventricular tachycardia, the automatic implantable cardioverter defibrillator can play a role in the health of selected patients. Recent advances in this area allow a ray of hope. Dr. Saksena in New Jersey has introduced a nonsurgical technique for implanting the automatic cardioverter defibrillator. Clinical trials have shown this to be highly successful.

VI. CONCLUSION

We have a long way to go in the management of simple premature beats, more complex extra beats, ventricular tachycardia, and the prevention of ventricular fibrillation, which is the cause of death in many heart patients.

Questions still to be answered include the following:

1. Are the drugs effective in suppressing the abnormal rhythm?
2. Do they prevent ventricular fibrillation and prolong life, especially during and after a heart attack?
3. How serious are their side effects, including the precipitation of more dangerous heart rhythms?
4. Is their use justified in the given individual?

At present, partial success with the use of complex drug combinations in the seriously ill has been achieved, yet life has not been prolonged. In addition to toxicity, several visits to the doctor and cost must be justified.

BIBLIOGRAPHY

- ACC AHA/ESC Guidelines for the management of patients with supraventricular arrhythmias — Executive summary. *J. Am. Coll. Cardiol.*, 42:1494–1529, 2003
- Alboni, P., Bott, G. L., Bald, N. et al. Outpatient treatment of recent-onset atrial fibrillation with the “Pill-in-the-Pocket” approach. *N. Engl. J. Med.*, 351:2384–2391, 2004.
- Becker, R. C. et al. Novel constructs for thrombin inhibition. *AM. HEAR. J.*, 149:S61–S72, 2005.
- Bourassa, M. G. et al. Angiotensin II inhibition and prevention of atrial fibrillation and stroke. *J. Am. Coll. Cardiol.*, 45:720–721, 2005.
- Eckardt, L., Probst, V., Smits, J. P. P. et al. Long-term prognosis of individuals with right precordial ST-segment-elevation Brugada syndrome. *Circulation*, 111:257–263, 2005.
- Ferguson, J. D., and DiMarco, J. P. Contemporary management of paroxysmal supraventricular tachycardia. *Circulation*, 107:1096, 2003.
- Gaita, F., Riccardi, R., Caponi, D. et al. Linear cryo ablation of the left atrium versus pulmonary vein cryo isolation in patients with permanent atrial fibrillation and valvular heart disease: Correlation of electro-anatomic mapping and long-term clinical results. *Circulation*, 111:136–142, 2005.
- Halperin, J. L. et al. Ximelagatran: Oral direct thrombin inhibition as anticoagulant therapy in atrial fibrillation. *J. Am. Coll. Cardiol.*, 45:1–9, 2005.
- Hanna, I. R., Langberg, J. J. et al. The shocking story of azimilide. Editorial. *Circulation*, 110:3624–3626, 2004.
- Hazel SJ, Paterson HS, Edwards JRM et al. Treatment of Atrial Fibrillation via Energy Ablation. *Circulation*, 111:e103–e106, 2005.
- Jongbloed, M. R. M., Bax, J. J., Lamb, H. J. et al. Multi-slice computed tomography versus intracardiac echocardiography to evaluate the pulmonary veins before radiofrequency catheter ablation of atrial fibrillation. *J. Am. Coll. Cardiol.*, 45:343–350, 2005.
- Khan, M. G. In *Heart Disease Diagnosis and Therapy*, second edition. Humana Press, New Jersey, 2005.
- Khan, M. Gabriel. *Cardiac Drug Therapy*, sixth edition, W. B. Saunders, Philadelphia, 2003.
- Khan, M. Gabriel. *Rapid ECG Interpretation*, second edition, W. B. Saunders, Philadelphia, 2003.
- McMurray, J., Køber, L., Robertson, M. et al. Anti-arrhythmic effect of carvedilol after acute myocardial infarction. *J. Am. Coll. Cardiol.*, 45:525–530, 2005.
- Montenero, A. S., Bruno, N., Antonelli, A. et al. Long-term efficacy of cryo catheter ablation for the treatment of atrial flutter. *J. Am. Coll. Cardiol.*, 45:573–580, 2005.
- Packer, D. L., Keelan, P., Munger, T. M. et al. Clinical presentation, investigation, and management of pulmonary vein stenosis complicating ablation for atrial fibrillation. *Circulation*, 111:546–554, 2005.
- Page, R. L. et al. Newly diagnosed atrial fibrillation. *N. Engl. J. Med.*, 351:2408–2416, 2004.
- Rossenbacker, T., Mubagwa, K., Jongbloed, R. J. et al. Novel mutation in the Per-Arnt-Sim domain of KCNH2 causes a malignant form of long-QT syndrome. *Circulation*, 111:961–968, 2005.
- Saksena, S. Nonpharmacologic therapy for cardiac arrhythmias, cardiac pacing, implantable cardioverter defibrillators, catheter, and surgical ablation. In *Heart Disease Diagnoses and Therapy*, M. Gabriel Khan, ed. Williams & Wilkins, Baltimore, MD, 1996.
- Saksena, S., Prakash, A., Ziegler, P. et al. Improved suppression of recurrent atrial fibrillation with dual-site right atrial pacing and antiarrhythmic drug therapy. *J. Am. Coll. Cardiol.*, 40:1140, 2002.
- Singer, I., Hussein, A., Niazi, P. T. et al. Azimilide decreases recurrent ventricular tachyarrhythmias in patients with implantable cardioverter defibrillators. *J. Am. Coll. Cardiol.*, 43:39, 2004.
- Wachtell, K., Hornestam, B., Lehto, M. et al. Cardiovascular morbidity and mortality in hypertensive patients with a history of atrial fibrillation. *J. Am. Coll. Cardiol.*, 45:705–711, 2005.

Arteriosclerosis

- I. Diseases Causing Arteriosclerosis
- II. Atherosclerosis

GLOSSARY

adventitia the outermost lining of the vessel wall.

epistaxis hemorrhage from the nose.

hyperplasia abnormal increase in the number of normal cells in normal arrangement in an organ or tissue which increases its volume.

intima the innermost lining of the vessel wall that is in contact with flowing blood.

media the middle wall of arteries.

retinopathy noninflammatory disease of the retina, particularly caused by diabetes or hypertension.

THERE HAS BEEN MUCH CONFUSION IN THE USE of the terms arteriosclerosis and atherosclerosis. Arteriosclerosis is a diffuse lesion which often affects long segments of the arterial tree in which there is usually a combination of hypertrophic and fibrous changes in the entire thickness of all layers of the arterial wall. The media and adventitia are commonly affected by this disease process. Atherosclerosis is the term used for atheroma of arteries. It is typically patchy with a focal lesion of the intima with degeneration. There are also plaques of atheroma jutting into the lumen of the vessel obstructing the flow of blood. (See chapter entitled "Atherosclerosis/Atheroma.")

I. DISEASES CAUSING ARTERIOSCLEROSIS

A. Hypertensive Arteriosclerosis

Prolonged hypertension causes the walls of the affected arteries to become firmer and thicker, and the lumen are often wider than normal. Arteries appear to be generally enlarged and they may become somewhat tortuous. These changes can be seen especially in the retinal arteries

(hypertensive retinopathy), kidneys, pancreas, and other organs. The lumen of minute arterial branches, however, are often diminished owing to thickening of the intima.

Microscopic examination shows that the arterial wall is generally thickened with a proliferation of connective tissue cells and formation of new tissue both in the intima and the media. There is a considerable amount of concentric fibrous thickening, often without atheroma formation. In the thickening of media there may be distinct evidence of muscular increase, but in most cases the muscle fibers are found to be undergoing replacement by fibrous tissue leading to distinct fibrosis of the media. There is, however, true muscular hypertrophy. In young subjects with severe kidney disease and severe hypertension, hypertrophy of the media occurs before secondary fibrosis has appeared. This hypertrophy is similar to hypertrophy of the myocardium in response to the increased workload imposed by the high pressures. In the thickened intima, there is distinct hypertrophy and hyperplasia of the longitudinal muscle layer next to the internal elastic lamina. A reactive increase in the supporting elements of the vessel wall occurs in both muscle and elastic tissue. This occurs in response to increased blood pressure. This type of musculoelastic hyperplasia can be arrested by some antihypertensive agents.

With hypertensive arteriosclerosis the walls of small vessels become swollen and hyaline and its lumen may be diminished. These changes may be observed in end-stage kidney disease caused by severe hypertension and nephritis. In advanced cases there are lesions of a more severe type in which patchy necrosis of the arterial wall occurs along with fibrous infiltration and thrombosis. A typical finding in patients with malignant hypertension is fibrinoid necrosis of arteries in the kidney and other organs. These hemorrhagic changes are classically observed in the retinal arteries that are severely damaged by malignant hypertension and reflect the extensive pathologic changes that occur in other organs including the kidney and brain. Cerebral hemorrhage may also occur. Epistaxis is not uncommon and red blood cells exuding from kidney lesions are also found in the urine.

B. Monckeberg's Sclerosis — Calcification of the Media

Calcification is frequent in the arterial system. A striking degree of calcification is that which occurs in the media of arteries, particularly in the elderly. Calcification of the media is far more common in large arteries such as the iliac and femoral arteries. Lime salts are deposited in the middle media in these patients and elevated blood pressure may be recorded, but the mean arterial pressure is normal. This condition is not caused by hypertension nor does it cause hypertension. This is essentially a senile change that rarely leads to senile gangrene.

C. Endarteritis Obliterans

Endarteritis obliterans is a reaction of the arterial wall to an irritant which approaches it from the outermost lining of the adventitia. This process may be initiated by syphilis in which the main lesions are endarteritis and periarteritis of the small arteries in association with infiltration of lymphocytes and plasma cells around them.

These lesions affect the vasa vasorum, the small arterioles that feed the media with blood. The aortic arch is also commonly affected by syphilitic lesions. The arch immediately above the aortic valve is usually involved leading to weakness of the arterial wall and aneurysm formation of the ascending part of the aortic arch. Syphilis commonly damages the aortic valve and dilates the aortic valve ring causing severe aortic regurgitation. The aortic arch shows thickened plaques and irregularity of the surface with formation of aneurysmal depressions. Narrowing of the orifices of the coronary artery at their origin from the aorta (ostia) may occur and cause angina. Syphilitic lesions may also affect the pulmonary arteries causing right heart strain and heart failure. The arterial damage by syphilis is therefore not considered a true form of arteriosclerosis and is regarded as a specific disease of the arteries that includes vasculitis.

D. Thromboangiitis Obliterans

This disease process is a segmental vasculitis that affects the peripheral arteries, veins, and nerves of the arms and legs. The renal, coronary, and cerebral vessels may also be involved. Thromboangiitis obliterans is sometimes called Buerger's disease as he was the first to describe it in 1908 in 11 amputated limbs.

The pathologic process of this disease is distinct from atheroma and arteriosclerosis. This condition is fortunately

rare and occurs in young persons usually less than age 40 who are cigarette smokers. The pathologic process consists of highly cellular thrombi composed of polymorphonuclear leukocytes forming micro abscesses. Occasionally multinuclear giant cells are observed. The inflammatory infiltrate affects the vascular wall, but the internal elastic lamina remain intact. There is usually considerable fibrosis of the media and adventitia. Similar changes may be present in the accompanying veins and phlebitis of the superficial veins of the arms and legs may be a prominent feature. It is important to note that atherosclerosis and arteriosclerosis are two distinct diseases that cause disturbances in arteries, not veins.

Thromboangiitis obliterans is common in Asia and rare in North America and western Europe. Most patients have symptoms before age 40 and more than 80% occur in men. Patients may complain of cold hands and feet (Raynaud's phenomenon) and develop digital ulcerations and gangrene. Several diseases may cause similar symptoms and signs including scleroderma, lupus erythematosus, mixed connective tissue disease, and antiphospholipid antibody syndrome. These diseases must be excluded before considering thromboangiitis obliterans as the diagnosis.

Diagnosis is based on the age of onset before age of 40, history of tobacco use, physical examination demonstrating distal limb ischemia, and exclusion of other conditions mentioned above. Angiography may show segmental lesions.

Treatment includes cessation of cigarette smoking. Biopsy of lesions may prove difficult to heal and reconstructive surgery is often not feasible because of the segmental lesions that may be present.

II. ATHEROSCLEROSIS

The word "atheroma" is derived from the Greek stem "athere," meaning porridge or gruel. When a plaque of atheroma is cut, one can see a gelatinous, thick, porridge-like material that contains cholesterol and other fatty material. The plaque of atheroma involves the intima and the middle wall of the artery. Apart from a rich fat content, the plaque has a preponderance of smooth muscle cells that are derived from the media. These smooth muscle cells are believed to be very important in the formation and growth of the plaque. Substances such as cholesterol and products released from blood platelets stimulate the smooth muscle cells to proliferate, thus enlarging the plaque.

The intima of the artery in contact with the blood is smooth. When atherosclerosis occurs, a plaque of atheroma juts into the lumen of the artery. The silky smooth lining of the arteries is damaged by the force of blood as it moves through arteries that are elastic and constantly moving in pulsation. With every pulse wave, the arterial wall yields and stretches; over many years some damage must occur. The damage is partially repaired by small blood particles (platelets), which clump together and plug the damaged surface. These platelet plugs form a temporary patch, just like the plug of coagulated blood that forms when you nick yourself and a very small clot forms. In the coronary arteries or aorta, small clots are commonly formed on the lining. Presumably, these clots are involved in the repair of injuries to the smooth lining of the arteries. These small blood clots are somehow welded into the lining as hard, thickened areas (fibrous plaques). The artery tries to strengthen its wall during this repair job.

The plaques of atheroma are sometimes smooth, bumpy, large, rough, and even ulcerated. Because the vessel wall gets hard (sclerosed), the term used for the disease is atherosclerosis (see the chapter Angina). A heart attack is caused by blockage of a coronary artery, and such a blockage is usually due to one or more of the following:

- A blood clot forms on a plaque of atheroma. Lipid rich plaques are prone to rupture but can be fissured or ulcerated and this often leads to clotting; the term atherothrombosis describes this serious complication of atheroma. See the chapter Atheroma/Atherosclerosis.
- A large plaque of atheroma nearly completely blocks the artery.
- Small blood particles (platelets) may stick to the surface of the plaque in clumps similar to sludge in pipes; the clumped material may dislodge and be moved downstream by the blood and may block a smaller artery.
- A coronary artery may go into spasm, especially at the site of a plaque, blocking the vessel for a few minutes or a few hours (coronary artery spasm).
- An increase in adrenaline can be produced under the influence of stress or other inciting factors causing

clumping of platelets that may lead to clot formation; excess adrenaline from any source can also produce electrical disturbances in the heart, especially ventricular fibrillation; in fibrillation the heart muscle stops contracting and quivers therefore no blood is pumped, causing cardiac arrest.

- The exact mechanism that leads to the formation of blockage by atheroma has defied medical research for the past 60 years; it is certain that a high level of LDL cholesterol, particularly oxidized LDL (bad) cholesterol, initiates and perpetuates atheroma formation and progression.
- Atherosclerosis causes blockage of arteries and is the cause of heart pain, angina, heart attacks, and death from coronary heart disease; blockage of arteries by atherosclerosis is the basic cause of heart attacks, stroke, aneurysm of the aorta, and poor circulation in the legs.

In the western world, the UK, Europe, Ireland, and Russia atherosclerosis is the most common disease affecting men aged 35–80 and women after age 55. Death due to atherosclerosis is several times more common than all forms of cancer. The underlying atherosclerotic disease of the coronary arteries leads to more deaths than any other disease in industrialized countries. This disease is much more common in young men than women. Women are fortunately protected from atherosclerosis up to age 55 because of estrogens. Because men commonly die from heart attacks between age 40 to 60, the disease in the left anterior coronary artery has been appropriately labeled “the widow-maker.”

BIBLIOGRAPHY

- Bickerstaff, L. K., Pairolero, P. C., Hollier, L. H. et al. Thoracic aortic aneurysms: A population based study. *Surgery*, 92:1103, 1982.
- Forrester, J. S. Toward understanding the evolution of plaque rupture. *J. Am. Coll. Cardiol.*, 42:1566–1568, 2003.
- Lie, J. T. The rise and fall and resurgence of thromboangiitis obliterans (Buerger's disease), *Acta Pathol. Jpn.*, 39:153–58, 1989.

Artificial Heart

- I. Electric Total Artificial Heart
- II. Left Ventricular Assist Device
- III. Is There a Logical Role for Ventricular Assist Devices?
- IV. New Frontiers

GLOSSARY

atherosclerosis same as atheroma, raised plaques filled with cholesterol, calcium, and other substances on the inner wall of arteries that obstruct the lumen and the flow blood; the plaque of atheroma hardens the artery, hence the term atherosclerosis (sclerosis = hardening).

heart failure a failure of the heart to pump sufficient blood from the chambers into the aorta; inadequate supply of blood reaches organs and tissues.

left ventricular assist device a device that can replace a left ventricle that is no longer able to pump blood into the aorta.

New York Heart Association class IV heart failure the worst stage, end-stage, severely symptomatic at rest.

thromboembolic clots or thrombi that break off from the interior lining of the heart; they are propelled by the blood and become lodged in an artery supplying blood to an organ or to the extremities.

CARDIOVASCULAR DISEASE IS THE MAIN CAUSE of death in the United States, Canada, UK, Ireland, and Europe. It accounts for more than 40% of total deaths in these countries. Many of these deaths are due to heart failure. Heart failure affects approximately five million Americans with more than half a million new cases diagnosed annually. The aggregate five-year survival rate of patients with heart failure is approximately 50%, but the one-year mortality rate is close to 50% for patients with severe heart failure (New York Heart Association class IV heart failure). Patients who remain in class IV heart failure for several months despite optimal medical therapy may require heart transplantation.

There is no doubt that cardiac transplantation has a role and provides beneficial relief of suffering in selected individuals. The one-year survival rate is more than 80%

and the 10-year survival rate is close to 50% for transplantation. This far exceeds the dismal survival rate obtained with the left ventricular assist devices that at two years is less than 20%. Following left ventricular assist device a transplant is necessary within one to six months. This calls for two operations within six months in very sick individuals. This is a major disadvantage of assist devices. Most important, there are fewer than 4000 donor organs available worldwide per year. The cost of two operations within six months is prohibitive as well as physically and mentally traumatic. A functional total artificial heart would be a dream come true.

I. ELECTRIC TOTAL ARTIFICIAL HEART

The first artificial heart implant was carried out by Dr. Denton Cooley in Houston, Texas, in a 47-year-old man with intractable heart failure using the Liotta artificial heart developed by Domingo Liotta. This artificial heart was based upon the laboratory work of Dr. Michael DeBakey.

The electric total artificial heart was designed for permanent use and was completely implantable. Pneumatic total artificial hearts have not proved successful in small group studies. The Jarvik-7-100 artificial heart, a pneumatic system developed by the physician-engineer, Robert Jarvik, was tried in four patients as a permanent implant. All four patients died because of infectious, hematologic, and thromboembolic complications. One patient lived for 20 months. This device was first use by Dr. William DeVries who implanted the device in Barney Clarke in 1982. The presence of percutaneous drive lines causes infectious complications and the bulky external drive unit makes pneumatic artificial hearts unsuitable for permanent implantation.

From 1970 to the present much investigational work has been done in the development of left ventricular assist devices as opposed to the development of a total artificial heart. This setback has delayed the development of the true total artificial heart. During the past decade, through

a contract program established by the National Heart and Lung Institute, two research teams have been developing an electric total artificial heart that is undergoing clinical testing in selected areas in the United States.

A. AbioCor

A completely novel approach to the artificial heart was conceived by engineers from the Abiomed company. The AbioCor is a totally implantable artificial heart that is electric as opposed to the failed Jarvik-7, which is a pneumatic system.

AbioCor is the Abiomed (Danvers, MA) total artificial heart. It has been tried in a few patients (see Fig. 1). The prosthesis replaces the right and left ventricles of the recipient and is an electrohydraulically triggered device that can provide a cardiac output of 4–8 L/minute with

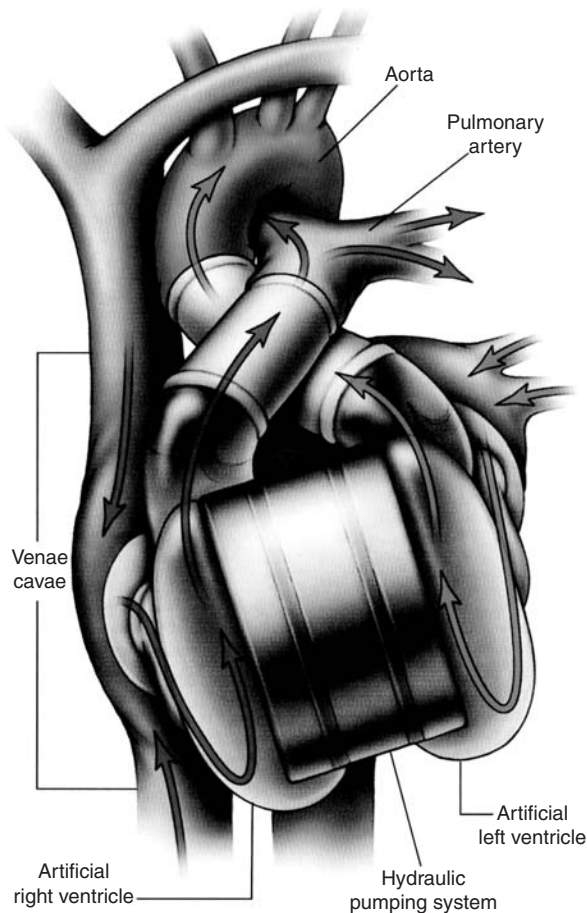

FIGURE 1 An artificial heart (AbioCor) shown implanted in a recipient's mediastinum. The prosthesis replaces the right and left ventricles of the recipient. (From Jessup, M. (2001). *N. Engl. J. Med.*, 345(20), p. 1492. With permission.)

a maximum of 10 L/minute. The design allows for physiologic flow in a pulsatile manner, and has been shown to provide satisfactory end organ perfusion. This device has the potential to provide a satisfactory outcome for patients suffering from end-stage heart failure who are not suitable for transplantation or when donor hearts are not available.

1. Implantable Components

A chest unit containing two blood-pumping sacs fill and empty alternately, supplying pulsatile blood flow through the aorta and pulmonary arteries, respectively. An artificial septum is situated between the two blood sacs and contains a miniaturized centrifugal pump that rotates at 5000–90,000 rpm. The pump then transports the hydraulic fluid alternatively to the right and left sides. Blood flows through artificial plastic trileaflet valves which act as atrioventricular and ventriculoarterial valves.

Rechargeable lithium ion cells provide energy to the pump for up to 30 minutes. The internal rechargeable batteries allow patients freedom for 15–30 minutes as the batteries are constantly charged from an external source. A microprocessor in the chest unit provides physiologic parameters: beat rate, motor speeds, and balance between the right and left pressures that control the pumping function of the heart. A disk-shaped internal transcutaneous energy transfer (TET) coil is placed in the subpectoral region.

2. External Components

The internal TET receives magnetic waves from an external TET coil, which transfers energy across the skin to the implanted device by a process of inductive coupling that converts the external energy to electrical energy. Thus, the device is totally internal with no cables through the skin. A console the size of a laptop computer houses a battery that powers the device for approximately 45 minutes. The external TET coil attaches to the console and provides a constant power supply. The console is plugged into a wall outlet and is disconnected for activities and travel.

B. Lionheart

1. Chest Size

Size constraints remain the most important hurdle. Patients must have an adequate chest cavity size or anteroposterior thoracic dimension.

2. Power Source

The Lionheart (Arrow, Reading, PA) electrical artificial heart uses a single, implantable energy converter to drive both ventricles that are implanted within the pericardium. It avoids the problem of using a separate external drive unit for each ventricle as is done with the pneumatic system. The electrical unit uses a single implantable energy converter to drive both ventricles and requires a minimum energy of 14 W. Unfortunately, implanted batteries are not capable of supplying the power that is required. The development of high-energy density batteries hopefully should eliminate the need for the present use of a primary external power source as this is a major hurdle still left to overcome.

II. LEFT VENTRICULAR ASSIST DEVICE

A. Systems

Left ventricular assist devices are implanted only in patients who are eligible for cardiac transplantation. These devices are used as bridges to transplantation. There are three left ventricular assist devices presently available:

Thoratec, the HeartMate, and Novacor.

The Thoratec system is paracorporeal: the pneumatic pump resides externally on the surface of the abdomen and is connected by cannulas to the heart and the ascending aorta. Figure 2 is taken from the Rose et al. study which reviewed long-term use of left ventricular assist devices. In the second and third systems the device is placed entirely within the chest cavity and abdomen. The energy conduit and vent, a drive line, is brought through the skin to the external energy source. Major problems with these systems include: a high incidence of infection of the device that usually occurs between 3 and 6 months, a high rate of bleeding by 6 months, and a probability of device failure greater than 33% at 2 years.

B. Clinical Study: Rose et al.

Study question: Does long-term use of left ventricular assist devices enhance survival and the quality of life?

Methods: Patients (129) with end-stage heart failure and eligible for cardiac transplantation were randomized to receive a left ventricular assist device (68 patients) or optimal medical management (61). All patients had symptoms classified as of New York Heart Association class IV heart failure.

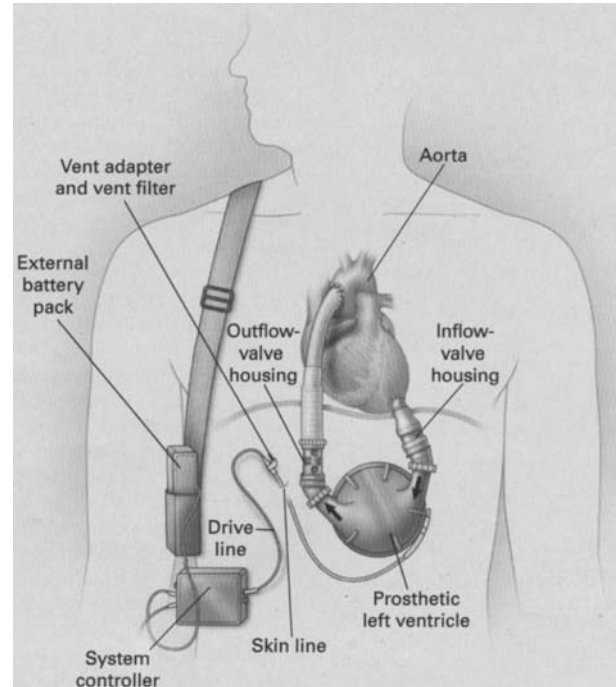
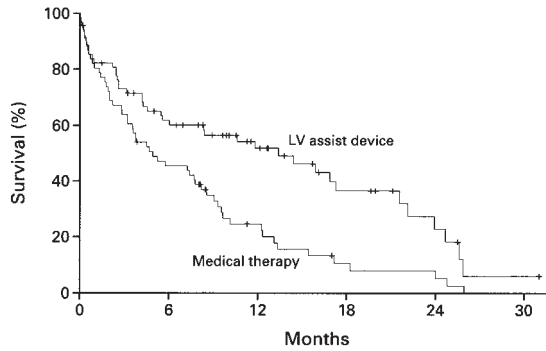

FIGURE 2 Components of the left ventricular assist device. The inflow cannula is inserted into the apex of the left ventricle, and the outflow cannula is anastomosed to the ascending aorta. Blood returns from the lungs to the left side of the heart and exits through the left ventricular apex and across an inflow valve into the prosthetic pumping chamber. Blood is then actively pumped through an outflow valve into the ascending aorta. The pumping chamber is placed within the abdominal wall or peritoneal cavity. A percutaneous drive line carries the electrical cable and air vent to the battery packs (only the pack on the right side is shown) and electronic controls, which are worn on a shoulder holster and belt, respectively. (From Rose, E.A., et al. (2001). *N. Engl. J. Med.*, 345(20), p. 1437. With permission.)

Results: The device caused a significant reduction in risk of death as compared with the medical therapy group ($p = 0.001$). Figure 3 shows the rates of survival at one year: 52% for the device group and 25% in the medical group ($p = 0.002$). The primary end point was 48% lower in the device group. Importantly, at 2 years survival was not significantly different: 23 and 8%, respectively ($p = 0.09$).

C. Perspective

This remarkable study is the first randomized study to ascertain whether a left ventricular assist device could provide long-term benefits and enhance survival in patients awaiting transplantation. The study clearly shows that the device can prolong life beyond optimal medical therapy in desperately ill New York Heart Association class IV



NO. AT RISK		0	6	12	18	24	30
LV assist device	68	38	22	11	5	1	
Medical therapy	61	27	11	4	3	0	

FIGURE 3 Kaplan-Meier analysis of survival in the group that received left ventricular (LV) assist devices and the group that received optimal medical therapy. Crosses depict censored patients. Enrollment in the trial was terminated after 92 patients had died; 95 deaths had occurred by the time of the final analysis. (From Rose, E.A., et al. (2001). *N. Engl. J. Med.*, 345(20), p. 1439. With permission.)

patients, but only for up to 6 months. The device was a failure at 24 months. In addition, complications and suffering remain intolerable and perhaps not justifiable: few patients who received the assist device survived longer than 2 years, the incidence of infection was 28% at 3 months, the incidence of bleeding by 6 months was 42%, and a probability of device failure was 35% at two years. Pulsatile ventricular assist device (VAD) has recently been approved by the FDA as a suitable alternative treatment for patients who are not candidates for heart transplantation. The drawbacks of these VADs include:

- Large size and noisy
- High incidence of device-related infection.
- Malfunction

Goldstein et al. reported on the safety and feasibility trial of the MicroMed DeBakey ventricular assist device as a bridge to transplantation (*J. Am. Coll. Cardiol.* 45:2005). The MicroMed DeBakey VAD is a miniaturized, implantable, electromagnetically actuated titanium axial flow pump with a single moving impeller. "The rotating motion of the impeller produces continuous flow. An ultrasonic flow probe provides direct measurements of pump flow. Wiring from the pump and the flow probe exit the skin and connect to a portable controller."

The 30 subjects were class IV patients who were inotrope and/or intra-aortic balloon pump dependent, and were accepted as candidates for cardiac transplantation.

All 30 patients survived the operation. There was no device failure. Twenty patients (67%) were successfully

bridged to transplantation, and 19 were well 30 days after transplantation.

Adverse events were:

- Reoperation for bleeding (n = 8, 27%)
- Hemolysis (n = 3, 10%)
- Device-related infection (n = 2, 6.7%)
- Pump thrombus (n = 4, 13%)
- Stroke (n = 3, 10%)

"As a result of this initial feasibility trial, the FDA has approved an expanded multicenter evaluation of the MicroMed DeBakey pump as a bridge to transplantation."

Advantages of the device include:

- Miniaturization
- A limited blood-contacting surface

III. IS THERE A LOGICAL ROLE FOR VENTRICULAR ASSIST DEVICES?

There are approximately fewer than 3000 donor organs available worldwide per year. In the United States alone, in 1999, 2184 patients with heart failure underwent heart transplantation. When a left ventricular assist device is implanted a donor heart must be available within approximately 3 months for the patient to maintain survival and quality of life.

Published data by treating teams indicate that patients who have received a device implant must be given priority for the next available donor heart. Thus virtually all individuals who can afford the expense (approximately \$150,000. for the device plus approximately \$50,000 for hospitalization) incurred in acquiring an assist device will receive the highest priority for obtaining the next available donor heart. The treating team recognizes that if the patient with the assist device does not undergo transplantation within a few months of device implantation, complications and death are to be expected within a year. Therefore, the availability of a donor heart is necessary for the success of the assist device, but as stressed above, there are limited donor hearts available.

In a study at the Montreal Heart Institute 16 patients received an assist device as a bridge to transplant. Thirteen of the patients underwent heart transplantation. Three died while waiting for a transplant. During this same period, 20 patients had a heart transplant without the use of an assist device. The time spent waiting for a transplant, however, was longer for those without an assist device: 87 days compared to only 17 days for patients who received an assist device.

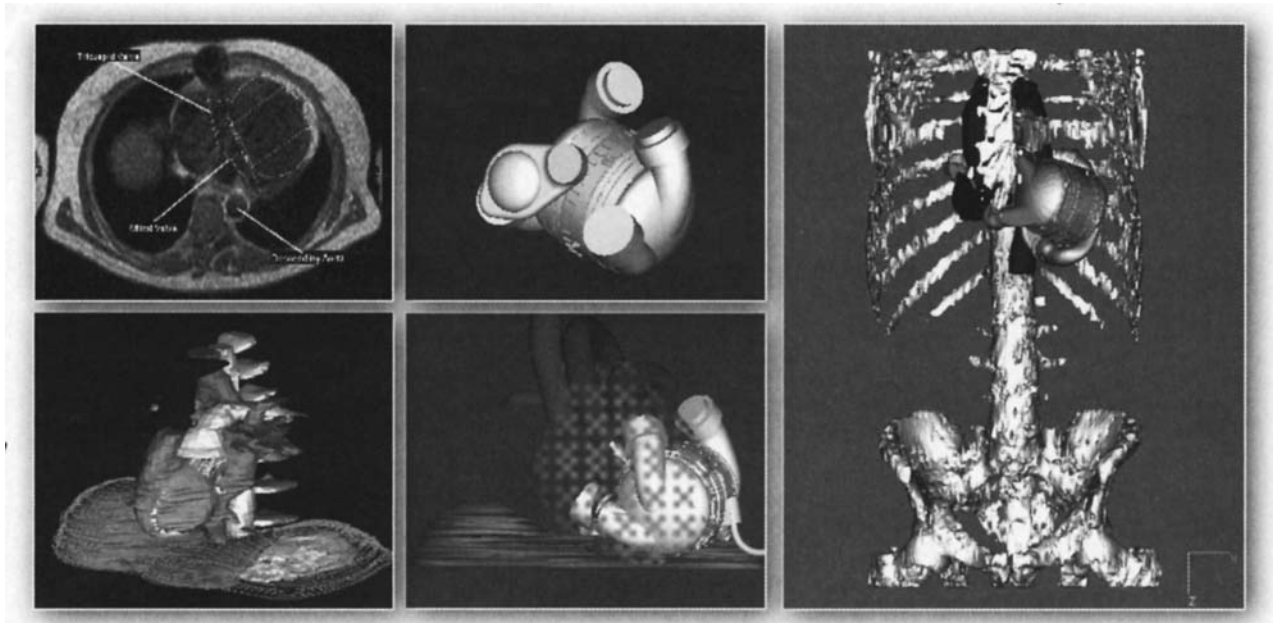

FIGURE 4 AbioFit. Three-dimensional reconstruction of patient's cardiothoracic anatomy with virtual implant of AbioCor. (From Samuels, L. (2003). *Am. Heart Hosp. J.*, p. 93. With permission.)

It appears that an assist device ensures heart transplantation which improves survival. This treatment selection bias may be unethical and does not solve the transplant problem in North America or worldwide. Extensive research and funding for the development of a total artificial heart is a more logical strategy for the management of end-stage heart failure in patients. Both the prevention of the underlying disease, atherosclerosis, that causes coronary artery disease and aggressive management of hypertension to prevent the occurrence of heart failure carries the key to future survival.

IV. NEW FRONTIERS

A ray of hope has been generated by the work of Dr. M. H. Yacoub, who describes a novel strategy: a combination of surgery and physiologic hypertrophy. The surgical process involves implantation of a left ventricular assist device and medical therapy with a drug, clenbuterol, a beta-2-agonist which induces reverse remodeling of the left ventricular myocardium and subsequent physiologic myocardial hypertrophy. This strategy improves left ventricular contractility and ejection fraction sufficiently to allow explantation of the assist device (the Harefield protocol).

The small study of 19 patients resulted in 4 deaths. Among the 15 patients, 11 had sufficient recovery from

heart failure and had the left ventricular assist device explanted. Ten patients are alive at two and a half years follow up and showed excellent exercise capacity with remarkable improvement in ejection fraction and lead a relatively normal life.

Clenbuterol changes phenotype, genotype, and gene expression in myocytes; in animal studies the agent has been shown to improve pressure volume relationships, increase myocyte size, and enhance organization of myofibrils. Dr. Yacoub indicates that not all hypertrophy is maladaptive. The strategy is to rest the heart and make it as small as possible, then activate the genes associated with the fetal heart and make it mature again. Once the heart is atrophied it is appropriate to enhance physiologic hypertrophy with clenbuterol or similar agents, which leads to improved left ventricle function.

BIBLIOGRAPHY

- Brown, B. G., Crowley, J. et al. Is there any hope for vitamin E? *JAMA*, 293:1387–1390, 2005.
- Goldstein, D. J., Zucker M., Arroyo L. et al. Safety and feasibility trial of the MicroMed DeBakey ventricular assist device as a bridge to transplantation. *J. Am. Coll. Cardiol.*, 45:962–963, 2005.
- Hon, J. K. E., and Yacoub, M. H. Bridge to recovery with the use of left ventricular assist device and clenbuterol. *Ann. Thorac. Surg.*, 75 (Suppl.) S36–S41, 2003.

- Jessup, M. Mechanical cardiac support devices — dreams and devilish details. *N. Engl. J. Med.*, 345:1490–92, 2001.
- Nielsen, J. C., Powell, A. J., Gauvreau, K., Marcus, E. N., Prakash, A., Geva, T. et al. Magnetic resonance imaging predictors of coarctation severity. *Circulation*, 111:622–628, 2005.
- Pagani, F. D., and Aaronson, K. D. LVAD therapy: The future is upon us. *ACC Curr. Rev.*, Sept/Oct 90–94, 2002.
- Rose, E. A., Gelijns, A. C., Moskowitz, A. J. et al. Long-term use of a left ventricular assist device for end-stage heart failure. *N. Engl. J. Med.*, 345:1435–43, 2001.
- Samuels, L. The AbioCor totally implantable replacement heart. *Am. Heart Hosp. J.*, 1:91–6, 2003.
- The HOPE and HOPE-TOO Trial Investigators.* et al. Effects of long-term vitamin E supplementation on cardiovascular events and cancer a randomized controlled trial. *JAMA*, 293:1338–1347, 2005.
- Wentzel, J. J., Corti, R., Fayad, Z. A., Wisdom, P., Macaluso, F., Winkelman, M. O., Fuster, V., Badimon, J. J. et al. Does shear stress modulate both plaque progression and regression in the thoracic aorta?: Human study using serial magnetic resonance imaging [Clinical research]. *J. Am. Coll. Cardiol.*, 45:6:846–854.
- Yacoub, M. H. A novel strategy to maximize the efficacy of left ventricular assist devices as a bridge to recovery. *Eur. Heart J.*, 22:534–540, 2001.

Aspirin for Heart Disease

- I. Historical Review
- II. Mechanism of Action
- III. Recognized Indications for Aspirin and Dose
- IV. Perspective

GLOSSARY

atheroma same as atherosclerosis, raised plaques filled with cholesterol, calcium, and other substances on the inner wall of arteries that obstruct the lumen and the flow of blood; the plaque of atheroma hardens the artery, hence the term atherosclerosis (sclerosis = hardening).

myocardial infarction death of an area of heart muscle caused by blockage of a coronary artery by blood clot and atheroma; medical term for heart attack or coronary thrombosis.

platelets very small disk-like particles that circulate in the blood along with red blood cells initiating the formation of blood clots; platelets clump and form little plugs called platelet aggregation, thus causing bleeding to stop.

I. HISTORICAL REVIEW

You do not have to believe in Adam and Eve to recognize the significance of an apple. The old saying “an apple a day keeps the doctor away” has been changed to “an aspirin a day keeps the doctor away” (see Fig. 1).

A. Hippocrates, 400 BC and Beyond

As early as BC 350, Hippocrates tried to relieve the pain of his patients by asking them to chew willow bark, a natural substance which contains salicylic acid. In 1763, *Reverend Stone of Chipping Norton*, England, showed the benefit of willow bark for individuals with ague and fever. Today pain can be relieved by aspirin, which also contains salicylic acid.

B. Von Gerhardt, 1853

The use of salicylic acid, however, did not become common until 1853 when Von Gerhardt of Bayer developed aspirin

and in 1899, Felix Hoffman, a Bayer chemist, used aspirin to treat his father’s rheumatism.

C. Lawrence Craven, 1953

The first clinical trial of aspirin in patients occurred from 1948 to 1956 when a general practitioner, Lawrence Craven, treated 1500 relatively healthy, overweight, sedentary men between the ages of 40 and 65. The result of the study reported in the *Mississippi Valley Journal* concluded that one aspirin a day was sufficient, because none of Lawrence Craven’s 1500 patients experienced a heart attack over the five-year course of treatment. This small study, however, did not influence physicians to prescribe aspirin to patients for heart problems.

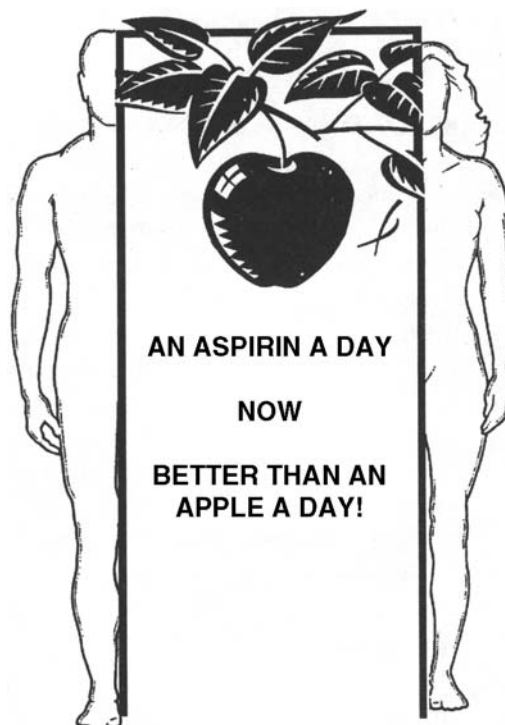

FIGURE 1

D. John Vane, 1971

Credit for influencing physicians to prescribe aspirin for heart problems must be given to John Vane. He showed that aspirin blocks the action of special substances in the body called prostaglandins. This action prevents blood platelets from clumping together to produce a clot. Thus, aspirin is referred to as an antiplatelet agent that is a mild blood thinner. A study in the UK by Elwood et al. found aspirin to be of no significant benefit when taken for a few years following a heart attack. Unfortunately, patients were enlisted at various durations after their heart attacks (from 3 to 6 months). Aspirin was not administered immediately following the myocardial infarction. This flaw in methodology and controversies delayed the use of aspirin for the next 10 years.

E. Lewis et al., 1983

The timely 1983 study by Lewis et al. in the United States heralded a new era, and aspirin became widely known as a life-saving drug. This study showed that one Alka-Seltzer containing 325 mg of acetylsalicylic acid, given to patients with severe angina (heart pains, unstable angina), caused a 49% reduction in nonfatal and fatal heart attacks. A Canadian study testing aspirin, sulfinpyrazone, or both in unstable angina confirmed Lewis' observation that aspirin given immediately to patients who presented to the emergency room with severe chest pain or unstable angina prevented serious events.

F. ISIS-2, 1988

This landmark study is the first to show the remarkable benefits of aspirin when given immediately following the onset of chest pain caused by myocardial infarction. The second International Study of Infarct Survival (ISIS-2), a study mounted in the UK, confirmed a marked increase in survival in a large group of patients given 160 mg of plain aspirin (noncoated) within 6 h of the onset of chest pain causing a heart attack. In that study, aspirin greatly improved the life-saving effects of streptokinase, a drug used to dissolve clots soon after the occurrence of a heart attack.

G. Primary Prevention, 1988

Finally, in 1988, a trial with 22,071 male U.S. physicians aged 40–84 given 325 mg of aspirin on alternate days for five years demonstrated that aspirin use resulted in a 44% reduction in the risk of nonfatal myocardial

infarction. This trial endorsed the use of small-dose coated aspirin preparations in normal individuals deemed at risk for coronary artery disease and its complications.

H. Swedish Trial, 1992

The Swedish angina pectoris aspirin trial studied 2035 patients with chronic stable angina without infarction. Aspirin, 75 mg, reduced the occurrence of infarction and sudden death by 34% in the treated patients versus placebo.

II. Mechanism of Action

Acetylsalicylic acid irreversibly acetylates the enzyme cyclooxygenase found in platelets. This enzyme is necessary for the conversion of platelet arachidonic acid to thromboxane A₂. The latter is a powerful platelet-aggregating agent and vasoconstrictor. The conversion to thromboxane A₂ and platelet aggregation can be initiated by several substances, especially those released following the interaction of catecholamine or platelets with subendothelial collagen. Endothelial and smooth muscle cells, when stimulated by physical or chemical injury, cause cyclooxygenase to convert membrane arachidonic acid to prostacyclin which is then released. Prostacyclin is a powerful inhibitor of platelet aggregation as well as a potent vasodilator. Aspirin reduces the formation of prostacyclin in the vessel wall and its undesirable effects. Low-dose aspirin inhibits thromboxane A₂ synthesis and platelet aggregation, but does not appear to inhibit prostacyclin production significantly.

Cyclooxygenase is also inhibited by all nonsteroidal anti-inflammatory drugs (NSAIDs), aspirin transfers and acetyl group to the enzyme irreversibly inactivating the enzyme (see Fig. 2). Other NSAIDs such as ibuprofen, act as a reversible inhibitors of cyclooxygenase and thus cannot be depended on to cause sustained cardioprotection.

Antiplatelet agents are not expected to prevent all forms of thrombotic events. Thrombi occurring in arteries are rich in platelets, so antiplatelet agents are partially effective. In obstructed arteries, with slow flow, the thrombus consists mainly of red cells within the fibrin mesh and very few platelets. This situation is similar to venous thrombosis where platelets are not predominant. The contents of a ruptured plaque are highly thrombogenic. Aspirin is only partially effective in preventing coronary thrombosis following plaque rupture, the usual cause of a heart attack. Thus, antiplatelet agents are not sufficiently beneficial in the prevention of coronary thrombosis occurring at the site of a ruptured atheromatous plaque.

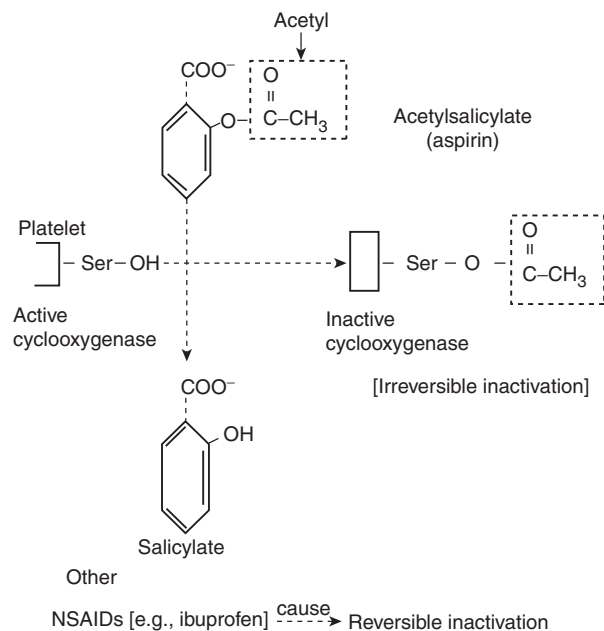

FIGURE 2 Irreversible inactivation of platelet cyclooxygenase by acetylsalicylate (aspirin).

III. RECOGNIZED INDICATIONS FOR ASPIRIN AND DOSE

A. Life-Saving Measures

Based on the proven benefits observed in ISIS-2, taking aspirin is a life-saving measure when taken within a few hours of chest pain or symptoms resulting from a developing heart attack. The dose should be one plain 325-mg tablet of aspirin, chewed and swallowed, or preferably, 2–4 chewable aspirins (80 mg each, a dose of 160–320 mg). It is important for the public at large to recognize that chewable aspirin taken immediately during the pain of heart attack can either prevent a heart attack or prevent death in a significant number of individuals. Most important, the nitroglycerin tablet or spray used under the tongue commonly prescribed and used by patients is of no value in preventing a heart attack or death when the process of myocardial infarction has begun. After a heart attack has been stabilized, an enteric-coated preparation of aspirin is then continued for several years and sometimes indefinitely.

B. Unstable Angina

Unstable angina is characterized by the occurrence of chest pain lasting 10–40 minutes, rarely more than an hour. Pain may wax and wane and eventually culminate in

a heart attack. The immediate use of 2–4 chewable aspirins may prevent a heart attack or death. For this protection 160–320 mg immediately then a 325-mg enteric coated aspirin daily for a lifetime is necessary.

C. Stable Angina

Stable angina is characterized by mild-to-moderate chest pain that recurs usually on exertion; stable angina may exist for 1–10 years without culminating in a heart attack. Aspirin is used in these patients to prevent heart attack or death. The recommended dosage is 80–160 mg daily. For many years a 325-mg enteric-coated aspirin daily has been recommended.

D. After Coronary Artery Bypass Surgery

A recent study has confirmed the protective benefits of aspirin use following bypass surgery. It is used to prevent blockage of the bypass graft. A dose of 325 mg daily is useful for the first few years following surgery. Because the atherosclerotic disease is still present in other coronary arteries, complications such as angina and fatal or nonfatal myocardial infarction may occur and aspirin is continued to prevent these episodes.

E. Prevention in Normal Individuals at Risk

Men over age 45 or women over age 60 with risk factors including: family history of heart attacks before age 60; high cholesterol levels greater than 5.5 mmol/L, or LDL cholesterol greater than 160 mg/dl (4 mmol); hypertension; or diabetes are at risk for the development of atherosclerotic coronary artery disease and its complications. The dose of one enteric-coated 80- to 81-mg aspirin daily is recommended for these patients. For dosages to prevent stroke, see the chapter Stroke/Cerebrovascular Accident.

A study reported (*N. Engl. J. Med.*, April 2005) indicated that in healthy women age 45–64, with one or no risk factors, low dose aspirin (100 mg alternate day) did not significantly reduce risk of heart attacks but prevented *nonfatal* stroke risk. I must point out that there is no gender difference in the efficacy of aspirin as some may believe.

In women age 35–55 heart attacks are rare compared to men. The result of the study is not surprising, therefore, because one cannot prevent heart attacks if they do not occur in that age group. The study was underpowered. The reason why strokes occur in women 45–55 when heart



FIGURE 3

attacks are uncommon at this age has as yet, not been clarified.

Most important, in the above study, aspirin did not prevent fatal stroke rates. The pathophysiologic mechanism causing fatal stroke and heart attack is similar. An atheromatous plaque undergoes erosion or rupture liberating a porridge like material that is intensely thrombogenic and the thrombus cannot be ameliorated by aspirin or other antiplatelet agents that do not affect the culprit thrombotic factors. In the study transient ischemic attacks (TIAs) were significantly reduced, however. This finding is not surprising because TIAs are caused by platelet emboli and platelet thrombi have been shown in randomised clinical trials to be significantly prevented by antiplatelet agents such as Plavix or the combination of aspirin and dipyridamole. A small stroke represents the continuation process of a transient ischemic attack some of which can be prevented therefore by aspirin or other antiplatelet agent.

Women ages 45–64 who have *more than one* cardiovascular risk factor should benefit significantly in the prevention of nonfatal strokes and TIAs with the use of small dose aspirin, 75–81 mg enteric-coated daily. Those with two or more risk factors may benefit from risk of heart attack. The above study used 100 mg alternate day and this may not be an adequate dose to prevent non fatal heart attacks. (See the chapter entitled Stroke/Cerebrovascular Accident.)

IV. PERSPECTIVE

Many individuals who fall into the above categories are not treated with aspirin by their physicians. In particular,

individuals are not advised regarding the proven life-saving value of chewable aspirin taken immediately during an episode of chest pain presumed to be due to an impending heart attack or episode of unstable angina. Individuals should be informed that chewable aspirin can save a life or prevent a heart attack, but that nitroglycerin under the tongue used in tablet or spray form does not prevent the occurrence of fatal or nonfatal myocardial infarction.

It is remarkable that after many years of research and with the expenditure of several billion dollars, only 4 of the more than 100 drugs administered by mouth to treat heart diseases cause prolongation of life. These agents are chewable aspirin, beta-blockers, ACE inhibitors, and the cholesterol-lowering drugs, statins. Thus an aspirin a day is now better than an apple a day. Two 80- to 81-mg soft chewable aspirin taken at the onset of a heart attack can prevent death or decrease the size of heart muscle damage (see Fig. 3).

BIBLIOGRAPHY

- Cairns, J. A., Gent, M., Singer, J. et al. Aspirin and sulfipyrazone or both in unstable angina. *N. Engl. J. Med.*, 313:1369, 1986.
- Craven, L. L. Experiences with aspirin (acetylsalicylic acid) in the nonspecific prophylaxis of coronary thrombosis. *Miss. Val. Med. J.*, 75:38, 1953.
- Elwood, P. C., Cochrane, A. L., Burr, M. L. et al. A randomized controlled trial of acetyl salicylic acid in the secondary prevention of mortality from myocardial infarction. *BMJ*, 1:436, 1947.
- Ferrari, E., Benhamou, M., Cerboni, P. et al. Coronary syndromes following aspirin withdrawal. *J. Am. Coll. Cardiol.*, 45:456–459, 2005.
- Gavaghan, T. P., Gebbski, V. G., and Baron, D. W. Immediate post operative aspirin improves vein graft patency early and late after coronary artery bypass surgery. *Circulation*, 83:1536, 1991.

- ISIS-2 (Second International Study of Infarct Survival) Collaborative Group. Randomized trial of intravenous streptokinase, oral aspirin, both or neither among 17187 cases of suspected acute myocardial infarction. *Lancet*, 11:349, 1988.
- ISIS-2 (Second International Study of Infarct Survival) Collaborative Group. Randomized trial of intravenous streptokinase, oral aspirin, both or neither among 17187 cases of suspected acute myocardial infarction. *Lancet*, 11:350, 1988.
- Juul-Moller, S., Edvardsson, N., Jhnmatz, B. et al. Double-blind trial of aspirin in primary prevention of myocardial infarction in patients with stable chronic angina pectoris. *Lancet*, 340:1421, 1992.
- Lewis, H. D., Davis, J. W., Archibald, D. G. et al. Protective effects of aspirin against acute myocardial infarction and death in men with unstable angina: Results of a Veterans Administration Cooperative Study. *N. Engl. J. Med.*, 309:396, 1983.
- Mangano, D. T. for the Multicenter study of Perioperative Ischemia Research Group: Aspirin and mortality from coronary bypass surgery. *N. Engl. J. Med.*, 347:1309, 2002.
- Ridker, P. M. and Others et al. A randomized trial of low-dose aspirin in the primary prevention of cardiovascular disease in women. *N. Engl. J. Med.*, 352: April ??, 2005.
- Steering Committee of the Physicians Health Study Research Group: Final report on the aspirin component of the ongoing Physicians Health Study. *N. Engl. J. Med.*, 321:129–135, 1989.

Atherosclerosis/Atheroma

- I. Introduction and Historical Background
- II. Pathology
- III. Pathogenesis
- IV. Vulnerable Atheromatous Plaques
- V. Clinical Studies
- VI. Perspective and Research Implications

GLOSSARY

angiogenesis functional new blood vessel growth.

atheroma same as atherosclerosis, raised plaques filled with cholesterol, calcium, and other substances on the inner wall of arteries that obstruct the lumen and the flow of blood; the plaque of atheroma hardens the artery, hence the term atherosclerosis (sclerosis = hardening).

atherothrombosis when a plaque of atheroma is fissured or ruptures, the contents of the plaque are highly thrombogenic and a clot (thrombus) forms rapidly causing complete occlusion of arteries leading to myocardial infarction, stroke, or other cardiovascular events (atheroma plus thrombosis = atherothrombosis).

diapedese the passage of blood cells through intact vessel walls.

endothelium the innermost part of the intima that comes in contact with circulating blood, a silky smooth layer of epithelial cells.

hemodynamics the study of the movement of blood and the forces involved in the circulation of the blood.

hydrodynamics a branch of the science of mechanics which treats liquids.

intima the innermost lining of the vessel wall that is in contact with flowing blood.

ischemia temporary lack of blood and oxygen to an area of cells, for example, the heart muscle, usually due to severe obstruction of the artery supplying blood to this area of cells.

leukocytes white blood cells.

monocytes scavenger white blood cells.

myocardial infarction death of an area of heart muscle due to blockage of a coronary artery by blood clot and atheroma; medical term for a heart attack or coronary thrombosis.

pathogenesis the development of morbid conditions or of disease, particularly the cellular events and reactions and other pathologic mechanisms occurring in the development of disease.

platelets very small disk like particles that circulate in the blood alongside with red blood cells initiating formation of blood clots; platelets clump and form little plugs called platelet aggregation,, thus causing bleeding to stop.

thrombogenic causes clotting of the blood.

I. INTRODUCTION AND HISTORICAL BACKGROUND

A. Incidence

Atherosclerosis dates back to ancient civilization and lesions have been found in arteries of Egyptian mummies. Obstruction of arteries by plaques of atheroma (atherosclerosis) is the basis for cardiovascular disease which accounts for approximately 40% of all deaths in western world and Europe. This single disease is the most common cause of death, particularly premature death, in industrialized countries. During the past decade the incidence of coronary artery disease has declined a little in most developed countries, still, there has been an increased incidence in many countries in eastern Europe and Asia.

The geographic variation in deaths from coronary artery disease is shown in Fig. 1 and Table 1 in chapter entitled "Angina." In 1990, the annual mortality from cardiovascular disease worldwide was 14.3 million in a population of 5.3 billion; this mortality will exceed 25 million in 2025, approximately 37% of the total 68 million deaths in a population of about 7.8 billion.

Of the estimated 1.1 million Americans who have a myocardial infarction annually, 650,000 are first-time

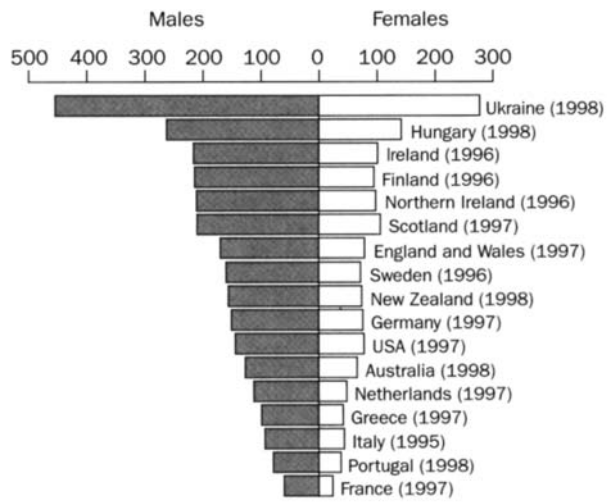

FIGURE 1 Mortality rates from coronary heart disease in selected countries. (Data are age-standardized rates per 100,000 (rounded)). (From 1997–1999 World Health Statistics Annual, 2001.)

events and 450,000 are recurrences. More than 45% of these events are fatal and associated with ventricular fibrillation.

B. Historical

Rokitansky, a famous pathologist, performed more than 30,000 autopsies causing him to postulate that atheroma was due to slow deposition of small thrombi at focal points on the arterial intima with subsequent organization into the wall of the artery. He publicized his theory in 1841.

The German pathologist Virchow, in 1858, recognized the participation of cells and the proliferative nature of atheroma formation. He used the term *endarteritis deformans*, indicating and that reactive fibrosis in response to injury was due to a repair mechanism.

In 1933 after fatty lesions were produced in the arteries of rabbits fed with a high-cholesterol diet, Anitschkow emerged as one of the influential figures in the field of experimental atherosclerosis. He considered atherosclerosis an infiltrative rather than a degenerative process that begins with the accumulation of lipid substances in the deep intima. He warned, however, that cholesterol was not the only factor.

In 1938, Winternitz indicated that atheroma occur partly from rupture of small capillaries of the arterial wall; hemorrhage into the plaque and organization of this material increased the size of atheroma. In 1949, Dugid revised the older theory of Rokitansky. He theorized that atheromatous lesions of the aorta and coronary arteries

may result from the slow deposition of thrombus at focal points on the intima with subsequent organization and infiltration with lipids. Dugid pointed out that small thrombi on the arterial lining are more common than realized, and that they are quickly incorporated into the intima by growth of the endothelium over the surface. Later they are converted into fibrous tissue in which variable degrees of fatty degeneration occur in the deeper layers.

The characterization of lipoprotein particles in the 1950s strengthened the cholesterol concept. Cholesterol, as the culprit for atheroma formation and coronary artery disease, still remained controversial in the minds of many cardiologists, researchers, and the public worldwide. In 1953, Lober provided the earliest provocative proof that diet could cause coronary artery disease. Ross and Glomsett, in 1976, merged the concepts of earlier investigators that atherosclerotic lesions develop only after chronic injury of the endothelial lining. The mechanisms of injury could be derived from three sources: hemodynamic (turbulence), immunologic, and biochemical. Later in 1986 Ross summarized the pathogenesis of atherosclerosis with this idea. Fluid dynamics, at certain sites, create an area of turbulence which in turn injures the endothelial lining so that it becomes more permeable to circulating lipoproteins. Circulating platelets clump together at the denuded site to form a micro clot; smooth muscles proliferate in this area probably under the stimulus of platelet-derived growth factor.

In 1994 the Scandinavian Simvastatin Study reviewed the controversial question: How important is the involvement of cholesterol, particularly LDL cholesterol? This question was only adequately answered in 1994, when statins were shown, in the hallmark Scandinavian Simvastatin Survival Study (4S), to cause a significant decrease in coronary artery disease mortality based on the reduction of total cholesterol and LDL cholesterol blood levels. This ended a 60-year-old controversy and ushered in the start of a new era in the prevention of atherosclerosis.

C. Perspective

Current evidence from extensive research indicates that all the pathogenic concepts outlined above are involved in the generation of atherosclerosis that causes coronary artery disease and other cardiovascular diseases including stroke and peripheral vascular disease. After 100 years of research, including the past 50 years of intensive research, we have only uncovered the tip of the iceberg. Cardiovascular disease remains rampant in Finland, Scotland, Northern Ireland, the Ukraine, the United States, Canada, Europe,

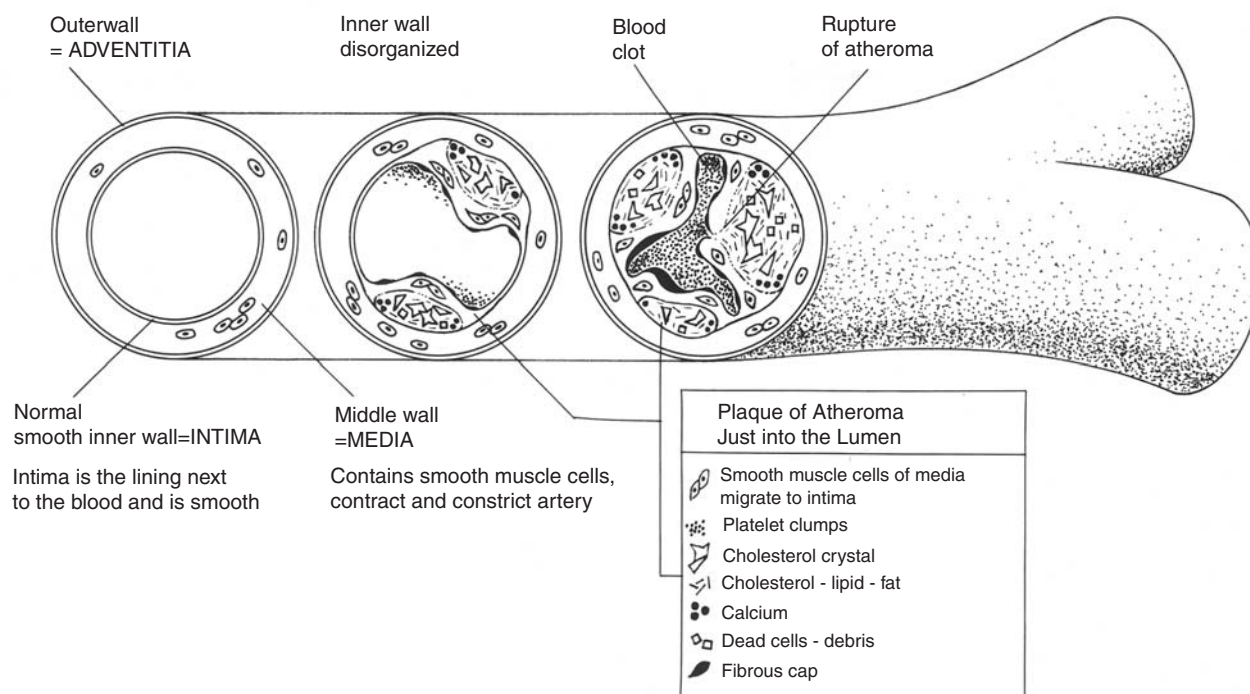

FIGURE 2 Atherosclerosis of the artery. (From Khan, M. Gabriel, *Heart Trouble Encyclopedia*, Toronto: Stoddart, 1996.)

and England and is increasing worldwide in the developing world. See Tables 1 and 2 in the chapter entitled “Angina.”

II. PATHOLOGY

A. Definition of Atheroma and Atherosclerosis

The word atheroma is derived from the Greek “athere” meaning porridge or gruel. When a plaque of atheroma is cut open one sees a gelatinous, porridge-like material which contains globules of cholesterol fat, neutral fat, saturated sterols, protein granules, crystals of cholesterol, fatty acids, calcium, and other cells. The amount of calcium in the lesion (calcification) is extremely variable. Fortunately, the porridge-like material does not touch the blood that flows through the artery, because nature covers the fatty material with a protective hard layer of cells called fibrous tissue. The atheromatous material forms a plaque, an opaque yellowish-white patch of thickening, that juts into the lumen of the artery. An atheromatous plaque therefore consists of a central fatty core that has a variable amount of lipids and calcium covered by a fibrous cap. Because the cap is hard and the medical word for hardness is “sclerosis,” the disease is commonly called atherosclerosis. The fibrous cap, however, may be quite thin and fragile and prone to fracture and rupture or show

erosion in some individuals. The exposed material is highly thrombogenic. Figure 2 gives a simplified representation of an atheromatous plaque and the subsequent rupture and blood clot that completely obstructs the artery.

B. Arteries Involved

Sites of predilection for atherosclerosis are illustrated in Fig. 3. Why some arteries are spared and others are severely involved is of particular concern to the author and appears to have received small attention from research workers. Scientific literature shows a paucity of research in this area versus a great amount of research related to lipoproteins and inflammation.

I. Aorta

The aorta is virtually always involved in cardiovascular disease. There must be a reason for this that has not received sufficient attention. As seen in the aorta, the process begins with the appearance of yellowish areas in the intima, which become distinctly raised. These focal areas increase in extent and thickness and become confluent. If a well-formed patch is incised, it is seen that a yellow lipid-rich pulpy material occupies the deeper part of the intima next to the media separated from the lumen by

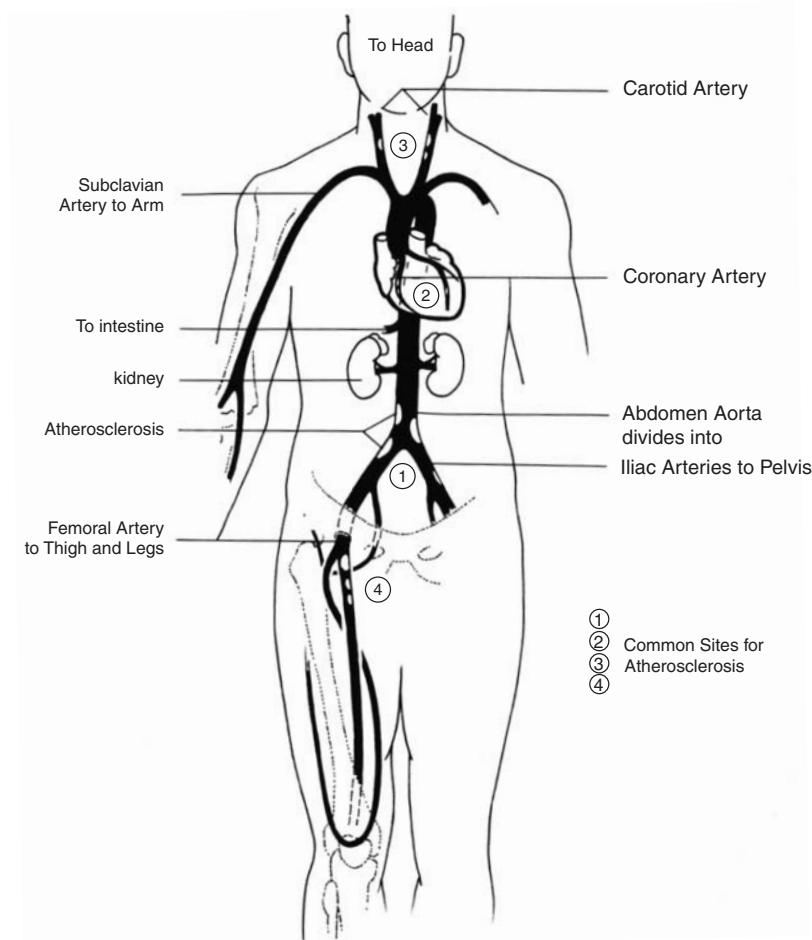

FIGURE 3 The heart and arteries.

connective tissue layers of varying depths. Sometimes this layer is thick, and the patches show a whitish color on surface view. The focal patches of atheroma are conspicuously related to the orifice of branches of arteries that stem from the aorta. Involvement of the aorta is usually most marked at the lower end before bifurcation into the iliac arteries (see Fig. 3).

Microscopic examination shows the lesions start first and are always more advanced in the deeper part of the intima, the fibers of which may be saturated with fatty material. When atheroma of the aorta is advanced, it may lead to weakening of the media of the artery resulting in expansion and dilatation of the wall. This is called an aneurysm.

2. Coronary Arteries

The coronary arteries are commonly involved in cardiovascular disease (see Figures in the chapter entitled “Anatomy of the Heart and Circulation”). This leads to

angina and culminates in fatal or nonfatal heart attacks. Sudden cardiac death commonly occurs in asymptomatic individuals. Why the coronary arteries are involved so often as opposed to arteries in the upper limbs intrigues this author and will be discussed in Section III. Also, the coronary arteries are affected by severe atheroma in men some 10 years before women are affected. Men therefore between the ages of 40 and 55 commonly suffer heart attacks. Heart attacks are uncommon in women until after the age of 60.

3. Carotid Arteries

The carotid arteries and their medium-sized branches as they enter the brain are commonly involved in atheromatous disease; this is the cause of stroke. The incidence of stroke in men and women ages 50–60 are similar however, and this difference between carotid artery atheroma and coronary atheroma remains unclear. The normal hormonal

status in women between ages 40 to 50 is believed to contribute to their cardioprotection.

4. Iliac and Leg Arteries

The iliac arteries as they leave the aorta and pelvis are prone to atherosclerosis as are the femoral arteries in the thighs and the popliteal arteries behind the knees. Obstruction in these arteries causes lack of circulation to the calf muscles. This lack of blood supply causes intermittent pain in the calf muscle during a brisk walk, and this condition is referred to as intermittent claudication. The Emperor Claudius limped because of a painful leg and, the word claudication is derived from his name.

5. Other Arteries Rarely Affected

The renal arteries that supply the kidney with blood are fortunately only occasionally affected by atheroma. Why the arteries supplying the upper limbs, the liver, and lungs are spared and the spleen and the entire small and large intestine are rarely affected is intriguing. Little attention has been given to this disparity over the last 20 years. Pulmonary arteries are involved only when there is high pressure in the pulmonary circulation; thus turbulence caused by a change in blood pressure is of importance. Individuals with constant, long-term systolic blood pressure in the normal range of 115–130 mmHg who show a change of 20 mmHg to reach borderline hypertensive I levels of 135–150 mmHg may be at risk for development of progressive atherosclerosis.

III. PATHOGENESIS

The precise cause and pathogenesis of atheroma formation remains unknown.

A. Current Pathogenic Theories

I. The Initial Lesion

The initial lesion is a small focus of injury of the intima caused by increased turbulence of blood at special arterial sites such as the orifice of branches — particularly that of the aorta as mentioned above — bifurcations, and curvatures that cause characteristic alterations in blood flow. This small area of injury incites a unique protective, nonspecific inflammatory response, but nature's healing

has to contend with further turbulent blood flow and further injury to the intima.

2. The Accumulation of Lipoprotein Particles

From observations in young adults dying of trauma and in rabbits fed a diet high in cholesterol and saturated fat, the accumulation of small lipoprotein particles in the intima has been noted to be one of the first ultrastructural alterations. This observation was noted in the 1950s and still finds space in major cardiology textbooks printed in 2002. The search of a 1958 Muir's textbook of pathology, provides similar lines: "fatty degeneration usually occurs in the intima. On microscopic examination they are found to be due chiefly to fatty material in stellate cells of the intima and macrophages, and to a certain extent in the endothelial cells. This fatty deposit is cholesterol and glycerol fat. Such patches have been found in children dying acutely of trauma. They indicate that fat is prone to accumulate within the intimal cells but the reason for this is obscure." It appears that much remains to be clarified regarding the pathogenesis of atheroma formation.

This author attempts to simplify the pathogenesis of atherosclerosis as follows: atheroma is the result, of hemodynamic forces that cause patchy arterial injury. This provokes a healing response which involves a nonspecific inflammatory reaction with the unfortunate accumulation of lipid substances from circulating blood. The damaged area is walled off by nature's band-aid, a protective fibrous cap. Smooth muscle cells play a major role in the healing process.

3. Endothelial Activation and Leukocyte Recruitment/Inflammatory Response

A nonspecific inflammatory response is central to the atherosclerotic process from the beginning to its complication of vessel occlusion which results in cardiovascular events.

Endothelial injury, or activation, is followed by an inflammatory process that commences with adherence of leukocytes to the endothelium and diapedese between endothelial cell junctions to enter the intima where they begin to accumulate lipids and transform into foam cells. Monocytes as well as T lymphocytes tend to accumulate.

The following molecular mediators play a major role in the development of atheroma:

1. Vascular cell adhesion molecule-1 (VCAM-1) facilitates attraction of leukocytes to the endothelial surface. Studies indicate that rabbits given a normal diet showed

no expression of VCAM-1 but greatly increased expression of VCAM-1 and adherent leukocytes when the rabbits were fed a high-cholesterol diet.

2. Monocyte chemoattractant protein-1 (MCP-1) produced by the intima and smooth muscle cells from the medial wall of the artery assist monocyte transfer across the endothelium.
3. Monocyte activation results in the expression of scavenger receptors by macrophages and transformation of macrophages into foam cells. Macrophage-colony stimulating factor (M-CSF) has a key role in foam cell formation because it acts as a potent monocyte activator. Animal studies indicate that M-CSF deficiency causes decreased atheroma formation in LDL-receptor-deficient mice.

Figures 4 and 5 give a simplified portrait of how the hidden key, turbulence of blood, initiates endothelial injury and dysfunction. This calls forth activated macrophages to the scene of injury followed by accumulation of oxidized LDL cholesterol and a nonspecific inflammatory response occurs. This response is similar to that observed following allergic reactions, autoimmune processes, and trauma, but with the unique features imposed by the silky, smooth endothelial lining of arteries that has a protective, strong media (see Fig. 2). The media contains smooth muscle cells which migrate into the injured area to assist in healing the minute wound. Much research has been done on the smooth muscle cell and its important contribution to the atherosclerotic process. The contribution of the smooth muscle cells, however, commences after the injury has been inflicted. Figure 5 illustrates further details.

It has been noted that increased turbulence of blood at specific arterial sites causes rolling and adherence of monocytes and T cells. This is believed to be the result of the upregulation of adhesion molecules on both the endothelium and on leukocytes.

4. Intracellular Lipid Accumulation and Foam Cell Formation

Monocytes once trapped in the arterial intima imbibe lipid substances. This lipid-laden macrophage is called a foam cell. These macrophages are stimulated to divide under the influence of a co-mitogen, M-CSF, and interleukin-3.

5. The Smooth Muscle Cell Migration and Proliferation

Tough smooth muscle cells migrate from the media into the intima probably to strengthen the injured area.

The chemoattractants for smooth muscle cells appear to be platelet-derived growth factor secreted by activated macrophages. The smooth muscle cells also divide vigorously, but some cell death occurs.

6. LDL Cholesterol Involvement

LDL activates foam cells and causes injury to these cells within the intimal lesion. It appears that LDL cholesterol is chemotactic for other monocytes. This enhances the inflammatory response by stimulating the replication of monocyte-derived macrophages and the attraction of new monocytes into the early atheromatous lesion. This activity further stimulates migration and proliferation of smooth muscle cells into the intimal area of injury. The tough smooth muscle cells, along with other cellular and non-cellular components, assume a protective role in an endeavor to form a fibroproliferative barrier that thickens the arterial wall at the site of injury. This is nature's way of healing, but occasionally the healing process is incomplete, which results in a thin, fragile protective cap prone to erosion and rupture.

7. Infection

There is unconvincing evidence that certain infectious organisms including *Chlamydia pneumoniae*, cytomegalovirus, *Helicobacter pylori*, and others may be involved in the inflammatory process and evolution of plaque rupture. Increased antibody titers to these organisms have been used as predictors of further cardiac events in patients following a heart attack. Examination of atheromatous lesions has occasionally identified *C. pneumoniae*. Clinical trials using antibiotics have thus far not been beneficial, but this organism may contribute to destabilization of atheromatous plaques and may play a role in initiating plaque rupture. Clarification of this is necessary.

A recent study by Agmon et al. indicated that *C. pneumoniae* IgG antibody titers are not associated with the presence or severity of aortic atherosclerosis in the general population. This observation does not support a role for infection by this organism in the initiation or progression of atherosclerosis.

The levels of circulating markers of inflammation such as C-reactive protein, a marker of nonspecific inflammatory processes, are higher in patients with unstable coronary artery disease than in those with stable coronary disease. Persistent elevation of C-reactive protein in patients with unstable angina strongly predicts further serious cardiac events. The precise mechanisms by which early plaque formation initiates an inflammatory response

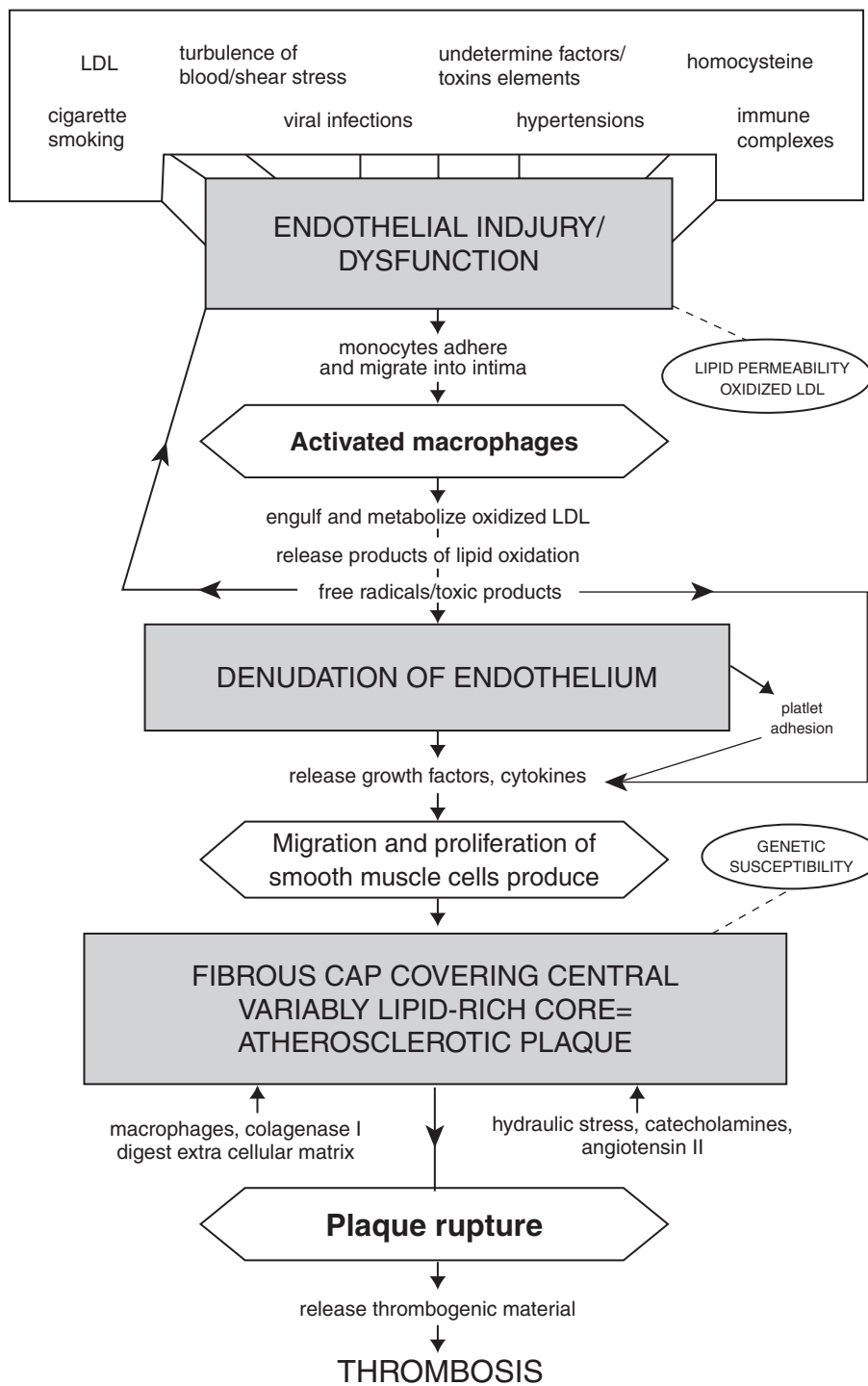

FIGURE 4 Pathogenesis of atherosclerotic (atheroma) plaque. (From Khan, M. Gabriel, *Heart Disease Diagnosis and Therapy*, second edition. New Jersey: Humana Press, 2005.)

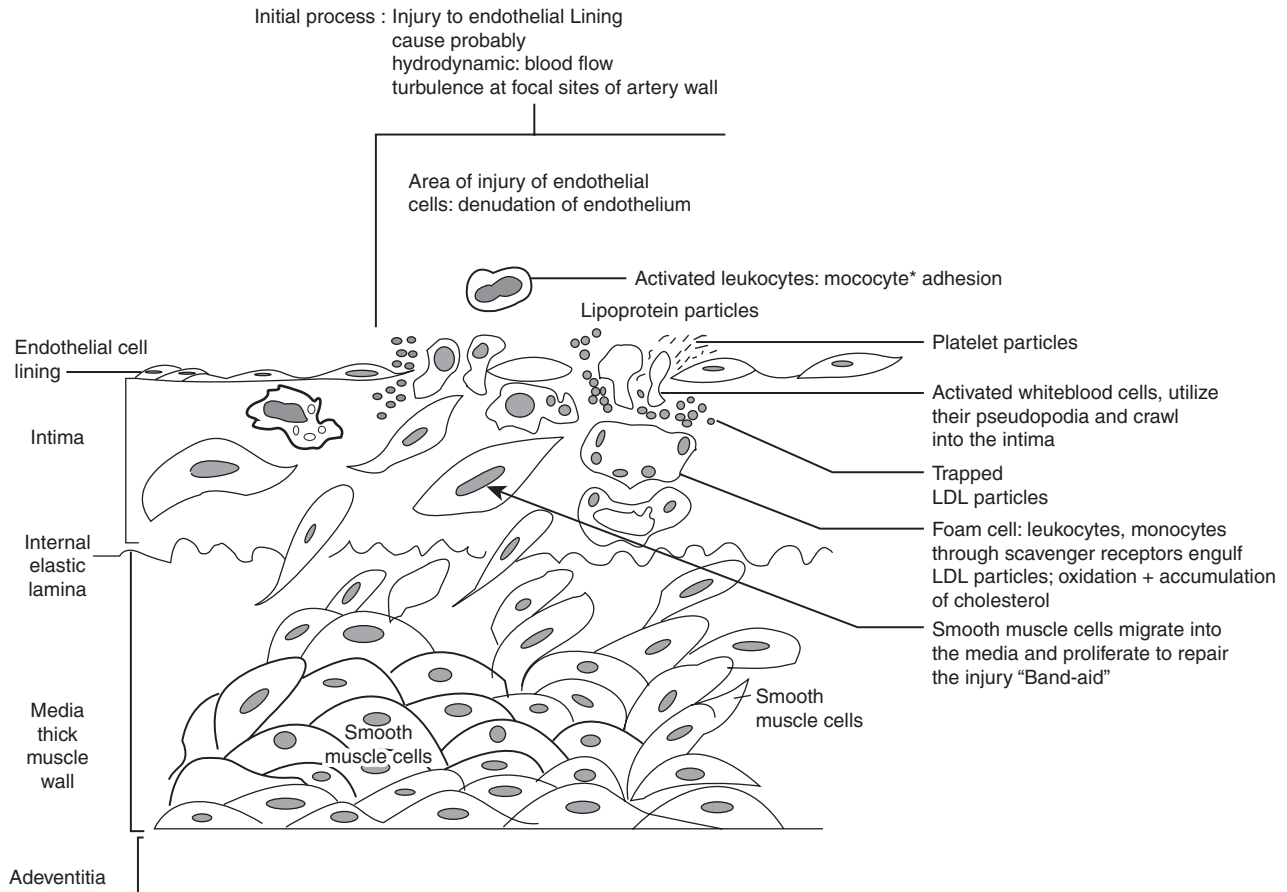

FIGURE 5 Simplified concepts: atheroma plaque formation in the early stages. * = activated white blood cells, utilize their pseudopodia and crawl into the intima.

in the absence of infection by microorganisms remains unclear. (see the chapter C-Reactive Protein.)

B. Hydrodynamic Forces/Pulsatile Blood Flow

Mechanical forces on the walls of arteries consist of three types:

(1) the tangential frictional force from the flow of blood across the endothelial surface, (2) the transmural pressure (the direct effect of pressure), and (3) wall stress as a result of pressure-induced wall deformation and subsequent cyclic strain. Increased blood pressure appears to promote atherogenesis through biomechanical effects of pulsatile blood flow, or cyclic strain, which has been observed to affect endothelial cell gene expression and function. Okada et al. have shown that changes in shear stress regulate endothelial production of several factors including vasodilators such as nitric oxide (NO) and prostacyclin and

vasoconstrictors such as endothelin-1. They also showed that increased cyclic stretch augments production of IL-8 and MCP-1 in a dose-dependent fashion.

Linear shear stress forces appear to be atheroprotective and associated with reduced production of reactive oxygen species (ROS). Oxidative stress results from the production of ROS, superoxide anion, and hydrogen peroxide. These are molecules that cause oxidative damage and trigger intracellular signaling cascades. The muscular wall of arteries is a rich source of ROS; the constituents of atheromatous plaques produce and use ROS. Hypercholesterolemia induced in rabbits causes an increase in ROS in rabbit aortas. Treatment with the antioxidant polyethyleneglycol superoxide appears to reverse impaired endothelial-dependent relaxation observed in rabbit aortic tissue. Dietary lowering of cholesterol reduces ROS production in rabbits.

Low shear stress and disturbed flow are associated with increased production of ROS and redox sensitive

upregulation of chemoattractant adhesion molecules (VCAM-1). Cyclic strain increases sICAM-1 expression by human endothelial cells in a time- and strain-dependent manner resulting in increased monocyte adhesion.

In vitro studies with animal models of hypertension have shown increased production of ROS in arterial tissues. Increased cyclic biomechanical strains modify macrophage function by increasing expression of scavenger receptors that participate in the deposit of lipid in the arterial wall.

C. Arteries of Predilection

As described in Section II, several arteries are spared atheromatous lesions.

1. Veins

Atheroma does not occur in veins because the thin-walled veins do not contain an appreciable media, and they are not exposed to the same hemodynamic stress and turbulence of blood that occurs in arteries.

2. Pulmonary Arteries

Atheroma is virtually never seen in the pulmonary arteries and pulmonary veins. These arteries are large and medium-sized. The pulmonary artery receives blood that is ejected from the right ventricle and circulates the blood to the lungs. It is similar to blood being ejected from the left ventricle into the aorta. The only difference is that the left ventricle pumps blood more vigorously and at higher pressures and velocity therefore submitting arteries to turbulent flow. Thus, the tendency for atheroma to be most marked in the lower part of the aorta is probably due to the increased hydrostatic pressure in that position. The right ventricle ejects blood into the pulmonary artery at a low pressure (25 mmHg vs. greater than 120 mmHg in the aorta). The resistance to flow of blood through the lungs is low, thus the right ventricle ejects blood at a much lower velocity than the left ventricle. Atheroma in the pulmonary arteries is virtually absent except in the presence of severe pulmonary hypertension. This author was intrigued by this finding more than 25 years ago. The finding seems to support the hypothesis that turbulent flow may initiate the lesions of atheroma in arteries at points in which maximum turbulence occur.

Vulnerable areas are present in the aorta which have to withstand the force of cardiac ejection velocity. Branches of the aorta, particularly the carotid, iliac, and

femoral-popliteal arteries are vulnerable. More important, the coronary arteries have a unique flow pattern as they are empty during cardiac systole and fill only during diastole. This spurt-flow phenomenon may perhaps explain their predilection to hemodynamic injury.

3. Arteries of the Upper Limbs

The arteries of the upper limbs include the subclavian and brachial arteries and medium-sized arteries similar to the ones in the legs or the carotid arteries of the head. Atheroma is not usually seen in these arteries. The reason why these arteries are not involved may hold the key to the puzzle of atheroma formation. The kidney arteries circulate the entire blood volume to be filtered by the kidney. Atheromatous lesions in these arteries were relatively rare compared to the involvement of the coronary and carotid arteries.

4. Aorta and Iliac Vessels

These vessels withstand the entire hemodynamic force transmitted directly by ejection of blood into the aorta from the powerful heart muscle. The velocity and turbulence is excessive at branching points including the bifurcation of the aorta and iliac arteries and in individuals who have high circulating LDL cholesterol lesions are expected to be more aggressive.

5. Coronary Arteries

The coronary arteries are commonly involved and this is not surprising. These are unique arteries. They are different from the arteries in the rest of the body. It is important to stress that these arteries collapse during the systolic contraction of the heart. They fill intermittently during diastole when the heart is relaxed. This intermittent flow to cardiac muscles that work harder and longer than any muscles in the body probably cause hemodynamic injury to the coronary arterial wall.

Agents that reduce turbulence and velocity of flow, particularly the beta-blocking drugs, may prove beneficial in clinical trials when used in conjunction with statins to reduce LDL cholesterol levels to less than 80 mg/dl in younger individuals at risk. It is of interest that in the management of patients with ruptured aortic aneurysms or dissecting aneurysms a beta-blocking drug is given immediately to quell the ejection velocity of blood that further tears the ruptured artery.

6. Angiogenesis in Plaques

During the past decade therapeutic angiogenesis has come into vogue. The use of angiogenic peptides is believed to produce therapeutic angiogenesis in the heart to improve blood supply and oxygen to muscles deprived of blood. Unfortunately, this may not be such a good therapeutic strategy. Muir's textbook of pathology from 1958 states:

Winternitz has shown that atheromatous patches may contain new capillaries, and these delicate vessels are exposed to the fluctuations in pressure within the arteries. It is not surprising, therefore, that these capillaries may rupture causing hemorrhage into such patches; hemorrhage into a plaque sometimes follows exertion with its consequent rise of blood pressure. Thereafter thrombosis often occurs during sleep.

It appears that old and important information has been lost amongst recent researchers. In some cases of myocardial infarction and sudden death, sudden occlusion of the artery occurs because of hemorrhage into the plaque followed by rupture of the plaque and subsequent thrombosis. The initiating event in these cases is not the usual cause of a heart attack — Unfortunately, because micro vessels within the plaque are friable and prone to burst, attempts to augment myocardial blood flow by enhancing new vessel growth by transfer of angiogenic proteins or their genes might have deleterious effects on lesion growth. They may initiate hemorrhage and plaque rupture, a disaster that researchers are trying desperately to prevent. See the section below, Vulnerable Atheromatous Plaques.

D. Other Risk Factors

1. Diabetes

The importance of diabetes as the cause of accelerated and progressive atherosclerosis is described in the chapter Diabetes and Cardiovascular Disease. The role of hypertension, elevated LDL cholesterol, and low levels of HDL cholesterol are discussed above. These factors in diabetic patients cause aggressive atheromatous obstruction of arteries at many sites in the body.

2. Cigarette Smoking

Antioxidant stress and other deleterious effects caused by cigarette smoking are believed to play a role in cardiovascular disease, but the exact mechanisms have not been clarified yet.

3. Familial Predisposition

Undefined genetic factors play a major role in the predisposition for the development of atheromatous coronary artery disease and its complication of myocardial infarction and sudden cardiac death. A family history of sudden coronary death before age 50 places the individual at high risk.

4. Stressful Lifestyle

A stressful lifestyle in individuals with other risk factors increases the likelihood of atheromatous coronary disease (see the chapter Stress and Heart Disease).

5. Age

Age is an overwhelming factor in cardiovascular disease. It is well known that atheroma formation is more prevalent in the elderly. Realistically the disease starts from approximately age 25 and increases gradually culminating in most populations between the age of 40 and 50. It takes 10–15 years for lesions to grow sufficiently to obstruct vessels, except when an asymptomatic plaque that is causing less than 60% occlusion of an artery accelerates and ruptures for reasons that are presently obscure and associated thrombosis occludes the artery. This commonly occurs in diabetics and in patients with high LDL cholesterol levels. In many patients the disease advances slowly between the age of 50 and 70 without causing symptoms. In women often after age 75 cardiovascular disease culminates in obstruction of an artery, myocardial infarction, or death. Men, unfortunately, are weaker and die earlier.

6. Homocysteine

There has been much talk in the past decade about the influence of elevated plasma homocysteine, atheroma formation and risk for cardiac events. The evidence linking elevated homocysteine levels and atherosclerosis is indeed weak. In a randomized clinical trial the administration of pyridoxine and folic acid caused a reduction of homocysteine levels, but resulted in a greater number of occlusions to intracoronary stents. In the Vitamin Intervention for Stroke Prevention (VISP) randomized controlled trial reduction of total homocysteine after nondisabling cerebral infarction had no effect on vascular outcomes during the 2 years of follow up.

IV. VULNERABLE ATHEROMATOUS PLAQUES

A. Rupture of the Plaque

Uneven thinning and fracture or fissuring of the plaque's fibrous cap leads to rupture. The porridge-like substances exposed to the flowing blood are highly thrombogenic and trigger thrombosis that blocks the lumen of the artery. This is the main underlying cause of a myocardial infarct (see Fig. 2). Fracture of the fibrous cap occurs often at the shoulders of a lipid-rich plaque where macrophages enter. The processes and mechanisms that underlie thinning fracture and rupture of plaques are unclear, and they are presently a subject of extensive research.

The provision of durable collagenous tissue processed by smooth muscle cells is important in maintaining the existence of the plaque's fibrous cap. Collagen provides most of the biomechanical resistance to disruption of the fibrous cap. Substances found in degranulating platelets appear to increase smooth muscle cell collagen synthesis that may reinforce the strength and viability of the fibrous cap. Additionally, in some lesions there is a marked decrease in the presence of smooth muscle cells or increased smooth muscle cell death within the plaque occurs, and this reduces collagen production. It is possible that the new capillaries and vessels within the plaque may be important for the survival of smooth muscle cells. Thus, angiogenesis may be hazardous.

Platelets play an important role in initiating clotting in arteries and arterioles. They form an initial plug or clot and are followed by the deposit of a fibrin mesh that forms a firm clot. Platelets are trapped by the material exposed by the fractured plaque and the first phase of thrombosis is initiated. Aspirin or platelet glycoprotein IIa/IIIb receptor blockers are used to prevent this deleterious platelet aggregation. Platelets are intriguing blood particles that require much research in order to uncover their therapeutic potential.

B. Superficial Erosion of the Endothelial Lining Covering the Plaque

Evidence of superficial erosion of the intimal lining has been observed in approximately 25% of patients who have sustained a myocardial infarction and died within a few hours. Endothelial cell desquamation through activation of basement membrane degrading metalloproteinases appears to be involved, but the mechanisms are unclear.

C. Hemorrhage into the Plaque

New capillaries and small vessels grow into the plaque and provide a useful function in that they may provide nutrient material for smooth muscle cells that form collagen necessary to strengthen the fibrous cap. These new vessels are, however, fragile and may burst causing a minute hemorrhage within the plaque. The pressure within the plaque may cause disruption of the fibrous cap, and thrombosis completes the occlusion of the artery.

V. CLINICAL STUDIES

A. Maehara et al.

Study question: What are the clinical and angiographic correlates of plaque rupture detected by intravascular ultrasound?

Methods: Three hundred plaque ruptures in 254 patients were assessed by angiographic and intravascular ultrasound.

Results: Plaque rupture occurred in 46% of patients with unstable angina and 33% of patient with myocardial infarction, but it was also observed in 11% of patients with stable angina and 11% of patients with no symptoms. The tear the fibrous cap occurred at the shoulder in 63% and occurred in 37% in the center of the plaque. Thrombi were common in patients with unstable angina. The plaque rupture site contained the minimum lumen area site in only 28% of patients; rupture sites had larger arterial and luminal areas and more positive remodeling than minimum luminal area sites.

Conclusions: Surprisingly, plaque ruptures usually do not cause lumen compromise.

B. Varnava et al.

Study question: Is there a relationship between the morphologic characteristics of coronary plaque vulnerability, lipid core size, and macrophage count, and coronary artery positive remodeling (no lumen narrowing), or increased constrictive adventitial fibrosis and thickening with negative remodeling (lumen narrowing)?

Methods: The hearts of 88 male patients with sudden cardiac death were assessed.

Results: When 108 plaques were studied, 59% had positive remodeling and 40% had negative remodeling. Plaques with positive remodeling had a larger lipid core (39% vs. 22%, $p = < 0.001$) and a higher macrophage count. Plaques with negative remodeling were associated

with greater thinning of the medial and adventitial wall opposite the plaque.

Conclusions: Plaques with positive remodeling have a high lipid content and macrophage count. This may explain why plaque rupture often occurs at sites with only modest lumen stenosis.

Perspective: M. J. Davies is well known for his work on atherosclerosis and its relationship to sudden death and myocardial infarction. The authors of this study include Dr. Davies who states: "Both pathologic studies and intravascular ultrasound studies suggest adventitial fibrosis and thickening influence negative remodeling (lumen narrowing). This may result in a more concentric lesion and stabilization of the site. Why lipid content varies with plaque remodeling is not all clear."

C. ApoA Milano; Nissen et al.

Study question: Low levels of HDL-C increase risk for atheromatous coronary artery disease. Can the administration of HDL-C or an HDL mimetic reduce atheroma volume?

Objective: ApoA-I Milano is a variant of apolipoprotein A-I that is isolated in individuals in rural Italy who exhibit very low levels of HDL and are atheroma free. Infusion of recombinant ApoA-I Milano/phospholipid complexes has been shown to produce regression of atherosclerosis in animal models. The effect of intravenous recombinant ApoA-I Milano/phospholipid complexes (ETC-216) on atheroma burden in patients with acute coronary syndromes was assessed.

Results: A recombinant ApoA-I Milano/phospholipid complex (ETC-216) administered intravenously for five doses at weekly intervals produced a mean (SD) percent atheroma volume decrease by -1.06% (3.17%) in the combined ETC-216 group as measured by IVUS. In the placebo group, percent atheroma volume increased by 0.14%. Although promising, these results require confirmation in larger clinical trials where the absolute reduction in atheroma volume in the combined treatment groups was -14.1 mm^3 or a 4.2% decrease from baseline ($P < 0.001$). Confirmation in large randomized trials is required.

D. Brousseau et al. Torcetrapib

Study question: Torcetrapib is a new investigational agent, which is a potent inhibitor of cholesteryl ester transfer protein (CETP). Inhibition of CETP raises HDL cholesterol levels. The effect of torcetrapib was assessed.

Results: In a small study of 19 patients with LDL cholesterol $< 40 \text{ mg/dl}$ (1 mmol/L) torcetrapib 120 mg daily administered with atorvastatin increased HDL-C by 61% ($P < 0.001$) and 46% ($P = 0.001$) without atorvastatin. The 120-mg, twice daily dosage increased HDL-C 106% ($P < 0.001$). Also, in the atorvastatin arm torcetrapib significantly reduced LDL-C by 17% ($P = 0.02$). Clinical trials in patients at high risk are underway.

E. Nissen et al. Reversal Study

Study question: Reversing atherosclerosis with aggressive lipid-lowering (REVERSAL) was done in a randomized trial study which compared the effects of an aggressive lipid-lowering regimen (atorvastatin 80 mg) daily and a moderate lipid-lowering regimen, (pravastatin 40 mg) on coronary atheroma burden as measured by intravascular ultrasound in 654 patients.

Results: Administration of atorvastatin resulted in a reduction from 3.9 mmol/L to a mean LDL-C 2.0 mmol/L (80 mg/dl), with no change in atheroma volume versus pravastatin reduction to 2.8 mmol/L (110 mg/dl) and a 2.7% increase in atheroma volume. The C-reactive protein decreased 35% with atorvastatin versus 5% with pravastatin.

VI. PERSPECTIVE AND RESEARCH IMPLICATIONS

After 100 years of research and controversies the pathobiology of the most common cause of death, atherosclerosis, is stated by renowned researchers to be rapidly changing, but this author believes it remains elusive. Positive answers regarding the pathogenesis and the evolution of beneficial treatment strategies can only be resolved in the distant future, perhaps another 25 years, unless aggressive and extensive research is carried out. The numerous studies that relate to plaque rupture and vulnerability of plaques, although important, will not resolve the pathogenesis of atherosclerosis or its prevention. Angiographic studies are numerous and intravascular ultrasound, computerized tomography that assesses calcium content of plaques, or the use of PET scans and MRI scans will not produce answers.

Substances that could strengthen and stabilize the fibrous cap would provide a major beneficial therapeutic strategy that may prevent plaque fissuring and rupture or erosions. Angiogenesis and gene therapy may promote hemorrhage into plaques, and caution is required by those who currently propose this investigational therapy. The reason why atheroma virtually never occurs in arteries

of the upper limbs, and the hepatic artery that supplies the liver and has a predilection for the descending aorta, coronary arteries, and carotid arteries must be thoroughly addressed. This author presumes that hemo- and hydrodynamic factors produce excessive turbulence at sites in arteries where the atheromatous lesion occurs. These forces create minute focal areas of injury to the endothelium of arteries. If this is the initial lesion, then it must be prevented if the problem of atherosclerosis is to be arrested. This hypothesis must be tested.

Therapeutic strategies that can be tried in the meantime include the use of a beta-blocking drug that has proven successful in reducing mortality in cardiac patients. Only 3 of the available 20 beta-blocking drugs meet this criterion: bisoprolol, carvedilol, and metoprolol. These agents may reduce turbulence at sites of atheroma induction. They should be tried in individuals at high risk at age 30, before major atheroma has formed. Treatment may be required for greater than 10 years in young individuals at high risk; that is preventive treatment similar to that of

asymptomatic hypertension. Individuals at risk include those with a family history of heart attack (fatal nonfatal) or angina prior to age 60; LDL cholesterol greater than 100 mg/dl; HDL cholesterol less than 0.9 mg; and it should be prescribed at the initial diagnosis of diabetes. In addition beta-blockers have been shown to prevent sudden death in patients with coronary artery disease and may prevent plaque rupture. The salutary effects of beta blockade are given in Fig. 1, the chapter Beta-Blockers. Figure 6 summarizes the major factors involved in the genesis of atheroma and the resultant cardiovascular events.

Prevention of atheroma formation and its dangerous consequences require treatment of the initiating factor, turbulent blood flow and optimal treatment of the five reasons that cause progression of the atheromatous lesion. Today's medicine does not address the treatment of turbulent blood flow (hyper- and hydrodynamic) factors that in all probability initiate the atheromatous lesion. A combined strategy of reduced turbulence in arteries and

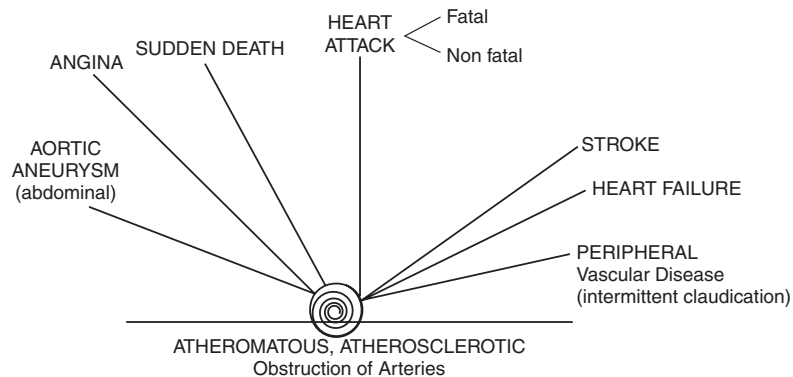

FIGURE 6 Consequences of obstruction of arteries.

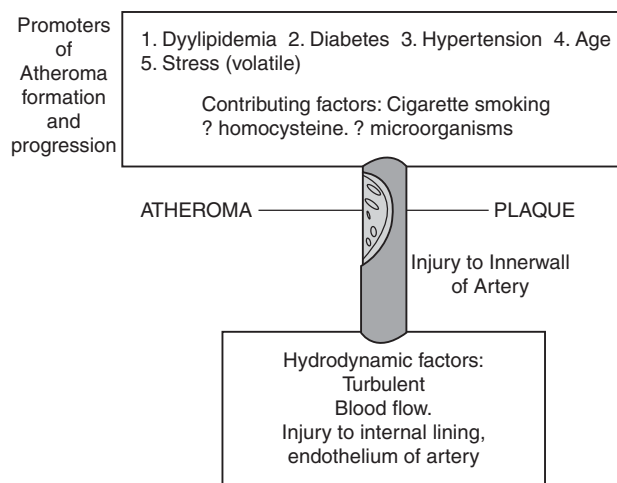

FIGURE 7 Major factors in the formation of atheroma and its progression and clinical complications.

the reduction of LDL-C to less than 2.0 mmol/L (80 mg/dl) with an increase in HDL-C to greater than 1.5 mmol/L (60 mg/dl) may have salutary effects.

BIBLIOGRAPHY

- Agmon, Y., Khandheria, B. K., Meissner, I. et al. The association between *Chlamydiae pneumoniae* seropositivity and aortic atherosclerosis. *J. Am. Coll. Cardiol.*, 41:1482-7, 2003.
- Aikawa, M., Sugimaya, S., Hill, C. et al. Lipid lowering reduces oxidative stress and endothelial cell activation in rabbit atheroma. *Circulation*, 106:1390-96, 2002.
- Ambrose, J. A., Barua, R. S. et al. The patho-physiology of cigarette smoking and cardiovascular disease: An update. *J. Am. Coll. Cardiol.*, 43:1731-37, 2004.
- Ambrose, J. A., D'Agate, D. J. et al. Plaque rupture and intracoronary thrombus in non-culprit vessels. *J. Am. Coll. Cardiol.*, 45:959-660, 2005.
- Brousseau, M. E., Schafer, E. J., Wolfe, M. L. et al. Effects of an inhibitor of cholesteryl ester transfer protein on HDL cholesterol. *N. Engl. J. Med.*, 350:1505-1515, 2004.
- Cheng, J.-J., Wung, B. S., Chao, Y. J. et al. Cyclic strain enhances adhesion of monocytes to endothelial cells by increasing intercellular adhesion molecule-1 expression. *Hypertension*, 28:386-91, 1996.
- Corti, R., Fuster, V., and Badimon, J. J. Pathogenetic concepts of acute coronary syndromes. *J. Am. Coll. Cardiol.*, 41:7S-14S, 2003.
- Forrester, J. S. Toward understanding the evolution of plaque rupture. *J. Am. Coll. Cardiol.*, 42:1566-1568, 2003.
- Fuster, V., Moreno, P. R., Fayad, Z. A. et al. State-of-the-art paper Atherothrombosis and high-risk plaque. Part I: Evolving concepts. *J. Am. Coll. Cardiol.*, 46:937-954, 2005.
- Goldstein, J. A. Angiographic plaque complexity: The tip of the unstable plaque iceberg. *J. Am. Coll. Cardiol.*, 39:1464-1467, 2002.
- Griendling, K. K., Sorescu, D., and Ushio-Fukai, M. NAD(P) H oxidase; role in cardiovascular biology and disease. *Circ. Res.*, 86:494-501, 2000.
- Hedblad, B., Ögre, M., Engström, G. et al. Heterogeneity of cardiovascular risk among smokers is related to degree of carbon monoxide exposure. *Atherosclerosis*, 179:177-183, 2005.
- Khan, M. Gabriel. Beta blockers: The cornerstone of cardiac drug therapy. In *Cardiac Drug Therapy*, sixth edition, W. B. Saunders, Philadelphia, 2003.
- Khunti, K., Samani, N. J. et al. Coronary heart disease in people of south-Asian origin: Important minority ethnic populations in many countries worldwide are people of south-Asian origin. *Lancet*, 364:2077, 2004.
- Lusis, A. J., Fogelman, A. M., Fonarow, G. C. et al. Genetic basis of atherosclerosis: Part II: Clinical implications. *Circulation*, 110:2066-2071, 2004.
- Maehara, A., Mintz, G. S., Bui, A. B. et al. The morphologic and angiographic features of coronary plaque rupture detected by intravascular ultrasound. *J. Am. Coll. Cardiol.*, 40:904-10, 2002.
- Moreno, P. R., Fuster, V. et al. The year in atherothrombosis. *J. Am. Coll. Cardiol.*, 44:2099-2110, 2004.
- Okada, M., Matsumori, A., Ono, K. et al. Cyclic stretch upregulates production of interleukin-8 and monocyte chemotactic and activating factor/monocyte chemoattractant protein-1 in human endothelial cells. *Arterioscler. Thromb. Vasc. Biol.*, 18:894-901, 1998.
- Petersen, S., Peto, V., Rayner, M. et al. Coronary heart disease statistics. London: British Heart Foundation, 2004.
- Reilly, M. P., Lehrke, M., Wolfe, M. L. et al. Resistin is an inflammatory marker of atherosclerosis in humans. *Circulation*, 111:932-939, 2005.
- Sakamoto, H., Aikawa, M., and Hill, C. C. Biomechanical strain induces class A scavenger receptor expression in human monocyte/macrophages and THP-1 cells. *Circulation*, 104:109-14, 2001.
- Shah, P. K. Mechanisms of plaque vulnerability and rupture. *J. Am. Coll. Cardiol.*, 41:15S-22S, 2003.
- Steven, E., Nissen, T., Tsunoda, E., Murat, T. et al. Effect of recombinant ApoA-I Milano on coronary atherosclerosis in patients with acute coronary syndromes. A randomized controlled trial. *JAMA*, 290:2292-2300, 2003.
- Takano, M., Inami, S., Ishibashi, F., et al. Angioscopic follow-up study of coronary ruptured plaques in non-culprit lesions. *J. Am. Coll. Cardiol.*, 45:652-658, 2005.
- Taylor, W. R. Hypertensive vascular disease and inflammation: mechanical and humoral mechanisms. *Curr. Hypertens. Rep.*, 1:96-101, 1999.
- Varnava, A. M., Mills, P. G., and Davies, M. J. Relationship between coronary artery remodeling and plaque vulnerability. *Circulation*, 105:393-43, 2002.
- Wong, ND. Detection of subclinical atherosclerosis: implications for evaluating cardiovascular risk. ACC Current J. Rev. March 2004.
- Yonemura, A., Momiyama, Y., Zahi, A., Fayad, Z. A. et al. Effect of lipid-lowering therapy with atorvastatin on atherosclerotic aortic plaques detected by non-invasive magnetic resonance imaging. *J. Am. Coll. Cardiol.*, 45:733-74, 2005.

Athletes and Sudden Cardiac Death

- I. Cardiac Causes of Sudden Death in Young Athletes
- II. Sudden Death not Associated with Cardiac Disease
- III. Athlete's Heart Versus Hypertrophic Cardiomyopathy

GLOSSARY

anomaly marked deviation from normal, especially as a result of congenital or hereditary defects.

arrhythmia general term for an irregularity or rapidity of the heartbeat, an abnormal heart rhythm.

atheroma same as atherosclerosis, raised plaques filled with cholesterol, calcium, and other substances on the inner wall of arteries that obstruct the lumen and the flow of blood; the plaque of atheroma hardens the artery, hence the term atherosclerosis (sclerosis = hardening).

Holter monitor a machine, the size of a handbook, that is capable of recording 24–48 h of continuous electrocardiographic monitoring; the tracing is used to assess abnormal heart rhythms, particularly serious arrhythmias.

hypertrophy increase in thickness of muscle.

myocardium the heart muscle.

sarcomere the contractile unit of a myofibril; sarcomeres are repeating units, delimited by the Z bands, along the length of the myofibril that make up the myocardium of the heart.

sudden cardiac death A death from cardiac cause that occurs instantaneously or within the hour of the onset of symptoms; the hallmark features are an instantaneous and unexpected time and mode of cardiac death.

syncope temporary loss of consciousness caused by lack of blood supply to the brain; fainting describes a simple syncopal attack.

ventricular cavity the chamber of the ventricle.

ventricular fibrillation the heart muscle does not contract but quivers; therefore, there is no heartbeat (cardiac arrest) and death occurs within minutes if the abnormal heart rhythm is not corrected.

ATHLETES AND SUDDEN CARDIAC DEATH CREATES a dilemma for most clinicians involved in sports medicine. Athletes may have unsuspected serious heart disease and still be relatively asymptomatic. Although rare, these

diseases may result in sudden death in young athletes with the catastrophic event emotionally impacting family members, friends, and classmates. In young athletes (median age 17 years), the frequency of cardiac sudden death occurs in approximately 1:70,000 individual student athletes during a 3-year career. Older athletes, particularly male joggers and marathon runners, however, have a much higher rate of exercise-related sudden death — reportedly approximately 1:30,000 per year. More than 90% of athletic field deaths occur in males and about 60% are at the median age of 17. Most important, Maron et al. indicated that the trigger for sudden death in athletes with unsuspected cardiac disease coincides with peak periods of competition training, particularly for organized team sports. In this setting, sudden death or major collapse has been associated with peak exercise training in 90% of athletes in the late afternoon and evening hours. This chapter deals mainly with sudden death in trained athletes, but similar deaths can occur in male high school students during training for team sports. The exact prevalence of this occurrence is unknown because of the lack of studies in this population group. The incidence of hypertrophic cardiomyopathy and other diseases discussed below should be similar in both trained and untrained athletes.

Causes of sudden death in young athletes include:

1. Hypertrophic cardiomyopathy, approximately 28%
2. Commotio cordis, approximately 20%
3. Coronary artery anomalies, approximately 14%
4. Myocarditis, approximately 5%
5. Unexplained left ventricular hypertrophy, approximately 5%
6. Marfan syndrome causing aortic dissection or ruptured aneurysm
7. Arrhythmogenic right ventricular dysplasia, approximately 3%; more common in some regions of Italy
8. Severe aortic stenosis, approximately 3%
9. Coronary artery disease, approximately 3%
10. Myxomatous mitral valve disease, less than 3%
11. Dilated cardiomyopathy, less than 3%
12. Less than 12% are represented by the long QT syndrome, cocaine and other drug abuse, heat stroke,

cardiac sarcoidosis, ruptured Berry aneurysm causing subarachnoid hemorrhage, and asthma or other pulmonary disorder

I. CARDIAC CAUSES OF SUDDEN DEATH IN YOUNG ATHLETES

A. Hypertrophic Cardiomyopathy

Maron et al. have contributed greatly to our understanding of the athlete and heart disease and indicated that hypertrophic cardiomyopathy is the single most common cause of sudden death in young athletes. This is all the more devastating to affected families and to perturbed

physicians because of the frequent absence of symptoms prior to death. Hypertrophic cardiomyopathy accounts for more than 33% of these deaths.

I. Definition

Hypertrophic cardiomyopathy is defined and diagnosed by the demonstration of unexplained left ventricular hypertrophy associated with nondilated ventricular cavities. Figure 1 illustrates morphologic components of the disease process. Note the conspicuous hypertrophy of the interventricular septum (labeled VS) that separates the left and right ventricle. The left ventricle cavity is reduced to a slit-like form as it merges with the aorta (AO), and the blood flow delivery from the left ventricle into the aorta

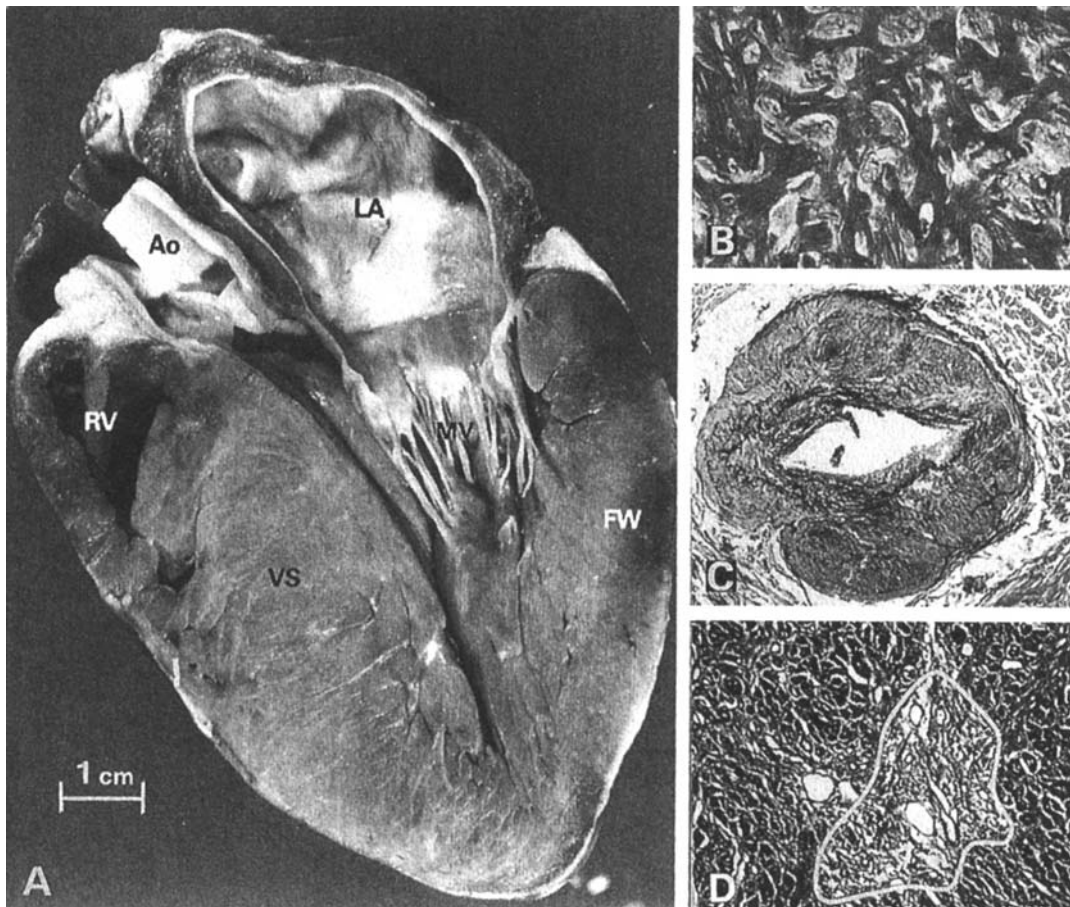

FIGURE 1 Morphological components of the disease process in hypertrophic cardiomyopathy (HCM), the most common cause of sudden death in young competitive athletes. A, Gross heart specimen sectioned in a cross-sectional plane similar to that of the echocardiographic (parasternal) long axis; left ventricular wall thickening shows an asymmetrical pattern and is confined primarily to the ventricular septum (VS), which bulges prominently into the left ventricular outflow tract. The left ventricular cavity appears reduced in size. FW = left ventricular free wall. B–D, Histological features characteristic of left ventricular myocardium in HCM. B, Markedly disordered architecture with adjacent hypertrophied cardiac muscle cells arranged at perpendicular and oblique angles. C, An intramural coronary artery with thickened wall, due primarily to medial hypertrophy, and with apparently narrowed lumen. D, Replacement fibrosis in an area of ventricular myocardium adjacent to an abnormal intramural coronary artery, and probably a consequence of ischemia. Ao = aorta; LA = left atrium; RV = right ventricle. (From Maron, J. (1997). Hypertrophic cardiomyopathy. *Lancet*, 350, pp. 127–133. With permission.)

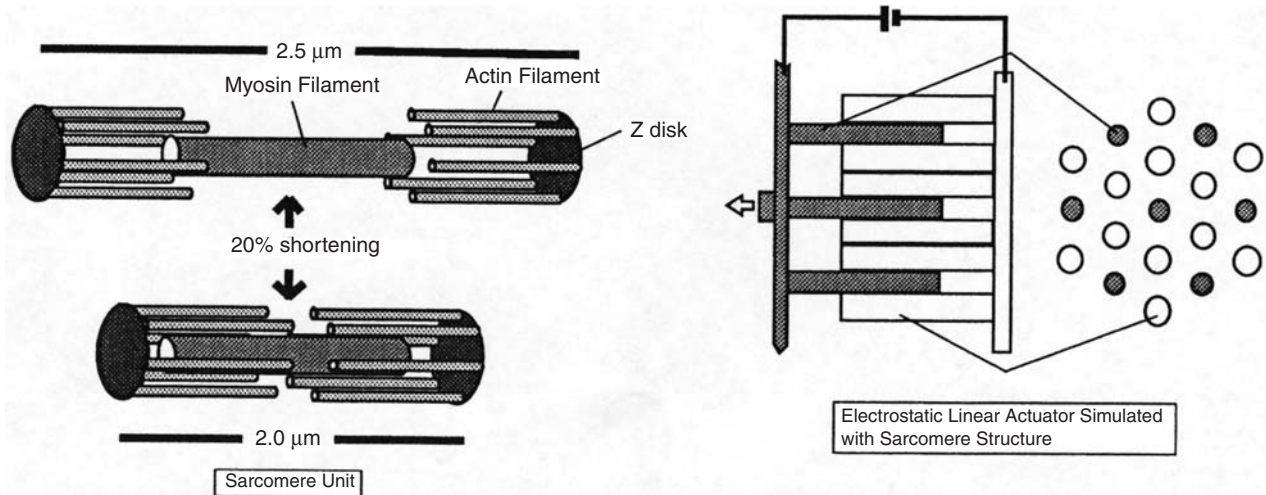

FIGURE 2 The structure of sarcomere looks like that of an electrostatic linear motor. S.C. Jacobsen proposed the structure of a musclelike actuator. (From *Micromechanical Devices*.)

is obstructed. Thus, initially the disease was appropriately called idiopathic hypertrophic subaortic stenosis (IHSS), then in the 1970s, it was renamed hypertrophic obstructive cardiomyopathy (HOCM). In the 1980s it became well known that many patients did not develop obstructive features, and the designation hypertrophic cardiomyopathy became used worldwide.

2. Genetics

Hypertrophic cardiomyopathy is a familial cardiac abnormality and is a relatively common genetically transmitted disease occurring in approximately 0.2% (1 in 500) of the general population. To date, 9 culprit genes and well over 100 specific mutations have been identified. Each of the culprit genes encodes sarcomeric contractile proteins in the heart muscle (see Fig. 2, the structure of the sarcomere, and figures in the chapter *Cardiomyopathy*).

The most prevalent of these genes is the beta myosin heavy chain (MYH7) that occurs in approximately 35% of cases. Cardiac troponins-T (TNNT2) occur in approximately 15% and cardiac myosin binding protein C in approximately 15%. Alpha cardiac actin (ACTC) is seen in less than 5% of cases. For further genetic details see the chapter *Cardiomyopathy*.

3. Risk of Death

Young athletes with asymptomatic, undetected hypertrophic cardiomyopathy can die unexpectedly. The group at highest risk are those few patients who have survived an episode of sustained ventricular tachycardia or ventricular

fibrillation. These patients have about an 11% chance of further serious event within 5 years and are managed with an implantable cardioverter defibrillator.

Risk assessment may be employed in a few individuals, but the fundamental problem with most proposed risk markers is that individually they appear to be only modestly predictive of medium-term risk of sudden death.

Despite clinical experience suggesting that adverse family history and syncope are harbingers of sudden death, most large studies, however, indicate that they are no more predictive of sudden death risk than nonsustained ventricular tachycardia on Holter monitoring and an abnormal exercise blood pressure response. Still, recurrent syncope associated with exertion in the young should be considered serious and assessed further.

McKenna et al. pointed out that “over the past four decades a number of clinical features have been proposed as markers of sudden death risk in patients with hypertrophic cardiomyopathy. Their application in clinical practice has, however, remained unsystematic and haphazard.” Genotyping is currently problematic in prognostic assessment and the physician does not have genotyping available as a routine clinical test. McKenna et al. suggested that future studies may confirm the observation of Ackerman et al., that selected MYH7 and TNNT2 mutations do confer increased risk of disease and related complications. In the Ackerman et al. study, however, a malignant mutation was only found in 3 (1%) of the 293 patients who had the following features: 24% had a family history of sudden cardiac death prior to age 40; 6% had extreme hypertrophy greater than 30 mm; and 8.5% had received an implantable cardioverter defibrillator. Thus, the group all had significant hypertrophic cardiomyopathy.

Most agree that asymptomatic patients with mild left ventricular hypertrophy less than 20 mm, a normal exercise blood pressure response, and absence of arrhythmia on Holter monitor with no family history of premature sudden death have a low risk of sudden death. Massive degrees of left ventricle hypertrophy greater than 30 mm in association with other risk factors are suggested by some to be a marker of risk. McKenna et al., however, pointed out that the majority of sudden deaths occur in patients with a wall thickness of less than 30 mm.

4. Advice to Athletes with Hypertrophic Cardiomyopathy

Athletes with an unequivocal diagnosis of hypertrophic cardiomyopathy should refrain from engaging in competitive sports and all forms of intensity training. Dehydration must be avoided because this further decreases the narrowed left ventricular cavity and obstruction of blood flow. All competitive athletes older than age 12 should have a thorough cardiac examination done by a family physician and an ECG. A positive family history of premature sudden cardiac death before age 40, the observation of a cardiac murmur, or an abnormal ECG may alert the physician to the diagnosis of hypertrophic cardiomyopathy or other cardiac disease that may herald a serious cardiac event.

B. Coronary Artery Anomalies

Congenital coronary artery anomalies account for approximately 20% of sudden cardiac death in young competitive athletes. As an example of one anomaly, the left main coronary artery should arise from the left sinus of Valsalva, but instead, in these patients, it arises from the right sinus. The left ventricle muscle mass consequently is deprived of an adequate blood and oxygen supply (see the sinus of Valsalva in the figures in the chapter *Anatomy of the Heart and Circulation*).

Unfortunately death may occur without manifesting symptoms such as exertional syncope or chest pain, and without abnormalities on the ECG at rest or on exercise testing. Symptoms such as exertional syncope, marked fatigue, and pallor observed soon after exertion require a diligent search for coronary artery anomalies. Investigations should include a transesophageal echocardiogram.

Most important, these anomalies can be corrected by bypass surgery. Unfortunately, participation in athletic screening does not reliably identify patients with coronary artery malformations (for more information see the chapter *Congenital Heart Disease*).

C. Coronary Artery Disease

Although coronary artery disease occurs commonly in men after age 40, it can also occur in individuals between the ages of 25 and 40. In one study of sports-related sudden deaths, not limited to competitive athletes, atheromatous coronary artery disease (as well as hypertrophic cardiomyopathy) was the leading cause of sudden death. Rupture of an atheromatous plaque may cause sudden death in young athletes, albeit rarely.

D. Ruptured Aorta

Rupture of the aorta accounts for approximately 5% of deaths in athletes, although the death may not be sudden. Rupture of the aorta is a characteristic of Marfan syndrome, a condition in which the strong muscular elastic middle wall of the aorta has a decreased number of elastic fibers and becomes weakened and prone to rupture.

E. Aortic Stenosis

Congenital malformations of the aortic valve may produce severe obstruction to the flow of blood from the left ventricle into the aorta. The abnormal architecture of the valves causes turbulent flow of blood that traumatizes the valves and causes fibrosis, rigidity, calcification of valve leaflets, and narrowing of the aortic orifice. This condition usually becomes symptomatic in young adults. Because of symptoms such as shortness of breath on exertion, syncope, tiredness, and fatigue, the condition is usually discovered and is easily diagnosed. Diagnosis is made when a loud murmur is heard over the aortic valve area with the stethoscope. The ECG and chest x-rays clarify the abnormality and surgery corrects the defect. Thus, these individuals do not often succumb to sudden death. This condition is reported to cause about 5% of deaths in athletes, but it is not related specifically to highly trained competitive young athletes whose defect would normally be picked up by screening.

F. Other Causes

Other causes include those listed below.

I. Myocarditis

This is usually caused by viral infections and is often a difficult diagnosis to establish. Chest pain, shortness of breath, palpitations, and abnormal heart rhythms may occur. A mild flu-like illness may be followed by an

asymptomatic phase in which no symptoms of heart disease are manifested, but during the next few months or years weakness of the myocardium may result in a cardiac event usually associated with malignant arrhythmias: ventricular tachycardia, ventricular fibrillation.

2. Mitral Valve Prolapse

This causes approximately 2% of cardiac deaths in athletes. Not all of the deaths are sudden. Mitral valve prolapse is a common condition, but serious complications are rare before age 45.

3. Arrhythmogenic Right Ventricular Dysplasia

This is a familiar condition usually associated with very fast heart rates (ventricular or supraventricular tachycardias). It can cause sudden death in young individuals including athletes. The disease accounts for less than 4% of sudden death in athletes. In a region in Italy this condition is the single most common cause of sudden death in competitive athletes and is reportedly more common than hypertrophic cardiomyopathy. The ECG and echocardiogram usually show abnormal features; the right ventricle muscle bundles are replaced by fibrous and fatty tissue.

4. Disturbances in the Electrical Conduction System

These disturbances of the heart rarely cause sudden death in athletes and other young people. In these cases, individuals are observed to have very slow heart rates and complete heart block.

5. The Brugada Syndrome

This can be a cause of sudden death, but is not often associated with sudden death in competitive athletes. In these cases, the ECG is always abnormal and is used to detect this very rare condition. For more information see the chapter Brugada Syndrome.

6. WPW and Long QT Syndrome

Sudden death in individuals with apparently normal hearts accounts for approximately 3% of deaths. Conditions that do not cause structural abnormalities and are therefore not detected on pathological examination at autopsy include: Wolff-Parkinson-White (WPW) syndrome and familial long QT syndrome. In WPW there is an

anomalous or accessory conduction pathway that allows rapid heartbeats in the range of 220–280.

A congenital abnormality of electrical conduction, the familial long QT syndrome, may escape detection because there is no structural abnormality to be found at autopsy.

Sudden death in athletes age 35–50 is common, because at this age asymptomatic and undetected coronary artery disease may be present. The coronary arteries may be involved with obstructive atherosclerotic disease that may cause a fatal or nonfatal heart attack or sudden death. Athletes over age 45 commonly have known atherosclerotic disease, undetected dyslipidemia or diabetes, and those who persist as recreational joggers, marathon runners, or engage in high-intensity squash or tennis may succumb to sudden death.

II. SUDDEN DEATH NOT ASSOCIATED WITH CARDIAC DISEASE

A. Commotio Cordis

Blunt, nonpenetrating blows to the chest are known to produce ventricular fibrillation, albeit rarely, without associated injury to the ribs, sternum, or heart. This condition is a more common cause of sudden death in athletes than all other conditions except hypertrophic cardiomyopathy. Commotio (disturbance, concussion) cordis is most common in individuals less than 16 years of age, because at this age the chest wall is still pliable and probably enhances transmission of the energy from the chest blow to the myocardium. Survival after commotio cordis occurs in less than 15% and may be achieved if cardiopulmonary resuscitation and defibrillation are readily applied.

In commotio cordis the blow may not be considered intense enough to cause death. Blows of sufficient magnitude may be produced by a blow from sports projectiles like a pitched baseball, hockey puck, or lacrosse ball; a karate blow or a blow delivered to relieve hiccups, or a collision between outfielders during baseball. Other injuries include a nonpenetrating blow to the neck that may rupture a vertebral artery and result in death from hemorrhage.

B. Cocaine, Anabolic Steroids, and Herbal Stimulants

The use of cocaine, anabolic steroids, and dietary supplements, particularly those containing ephedrine/ephedra (ma huang), are potent cardiac stimulants and may precipitate life-threatening arrhythmias.

III. ATHLETE'S HEART VERSUS HYPERTROPHIC CARDIOMYOPATHY

A. Differentiation

There is little doubt that young, highly trained athletes develop physiologic thickening of the muscular wall of the left ventricle. This is similar to the enlarged biceps of a bodybuilder or a blacksmith. This normal physiologic enlargement of the heart muscle (hypertrophy), can be difficult to differentiate from a mild form of hypertrophic cardiomyopathy. Maron et al. observed that athletes within this hypertrophic gray zone presented an important and common difficult problem in which the differential diagnosis between hypertrophic cardiomyopathy and athlete's heart must be resolved by noninvasive testing. Such testing often resolves the problem.

The athlete heart may show segmental thickening of the ventricular septum of 13–15 mm, which can be observed on echocardiography. The ECG in these athletes may show signs of ventricular hypertrophy, abnormal ST segment, and T-wave changes that may appear highly abnormal.

Differentiation can be observed in a number of ways.

1. The ECG shows the bizarre patterns seen in hypertrophic cardiomyopathy.
2. The echocardiogram usually shows asymmetric hypertrophy in hypertrophic cardiomyopathy, whereas the athlete's heart shows similar changes in both the left and right ventricle mass or a balanced enlarged heart. The left ventricular cavity is usually less than 45 mm in hypertrophic cardiomyopathy and in an athlete's heart there may be dilatation of the cavity to greater than 55 mm.
3. Left atrial enlargement is common in patients with hypertrophic cardiomyopathy, but it is not usually seen in an athlete's heart.
4. It is rare to find the athlete's heart in women.
5. Family history, gene mutation for hypertrophic cardiomyopathy, and changes seen on ECG and echocardiogram usually confirm the diagnosis. In more difficult cases an MRI may be used to differentiate the two conditions.

B. Clinical Studies

1. Scharhag et al.

Study question: Is the athlete's heart characterized by similar left and right ventricular hypertrophy?

Methods: Left and right ventricle mass, volume, and function in 21 male endurance athletes (27 ± 4 years), with a weight of 70 kg, were compared with 21 matched untrained control subjects and analyzed by MRI.

Results: All of the cardiac dimensions were significantly different between the endurance athletes and the control subjects.

Conclusions: Regular and extensive endurance training results in nearly identical changes that can be observed in the left and right ventricle muscle mass and in their volume and function. This leads to the conclusion that the athlete's heart is a balanced enlarged heart. In hypertrophic cardiomyopathy, however, the hypertrophy is usually asymmetric; if the left ventricular shows a more uniform (concentric) hypertrophy, then the right ventricle shows relatively little hypertrophy or an unbalanced hypertrophy.

2. Sharma et al.

Study question: High-endurance sports training may cause increased left ventricular wall thickness and may conflict with the diagnosis of hypertrophic cardiomyopathy. Information on echocardiographic dimensions in athletes age 14–18 is lacking. What echocardiographic measurement of hypertrophy would be considered important for the diagnosis of hypertrophic cardiomyopathy in young athletes?

Methods: Included were 720 elite athletes, (75% male, age 15–16) participating in endurance sports and 250 healthy sedentary control individuals who underwent echocardiography.

Results: Compared to controls, athletes had greater absolute left ventricular wall thickness (LVWT). No female athlete had an LVWT greater than 11 mm and only 3 trained male athletes had an absolute thickness greater than 12 mm. Each of the 38 athletes with LVWT exceeding predicted limits also showed enlarged left ventricular cavity dimensions of 50–60 mm.

Conclusions: Trained young athletes show greater absolute LVWT compared with non-athletes. Only a small proportion of athletes exhibited an LVWT exceeding upper limits, very rarely greater than 12 mm, and then always accompanied with left or right ventricular chamber enlargement. Hypertrophic cardiomyopathy, however, should be considered strongly in any trained young male athlete with an LVWT of greater than 12 mm and (females greater than 11 mm), and with a nondilated left ventricle.

BIBLIOGRAPHY

- Ackerman, M. J., Van Driest, S. L., Ommen S. R. et al. Prevalence and age dependence of malignant mutations in the beta myosin heavy chain and troponin T genes in hypertrophic cardiomyopathy: A comprehensive outpatient perspective. *J. Am. Coll. Cardiol.*, 39:2042–8, 2002.
- Burke, A. P., Farb, A., Virmani, R. et al. Sports related and non sports related sudden cardiac death in young athletes. *Am. Heart J.*, 121:568–75, 1991.
- Corrado, D., Basso, C., Rizzoli, G. et al. Does sports activity enhance the risk of sudden death in adolescents and young adults? *J. Am. Coll. Cardiol.*, 42:1959–1963, 2003.
- Lim, M. J., Forsberg, M., and Kern, M. J. Provocable pressure gradient across an anomalous left main coronary artery: A unique diagnostic tool. *Circulation*, 111:e108–e109, 2005.
- Maron, B. J. Sudden death in young athletes. *N. Engl. J. Med.*, 349: 1064–75, 2003.
- Maron, B. J. Sudden death in young athletes: Lessons from the Hank Gathers affair. *N. Engl. J. Med.*, 329:55–57, 1993.
- Maron, B. J., Pellica, A., and Spirito, P. Cardiac disease in young trained athletes: Insights into methods for distinguishing athlete's heart from structural heart disease with particular emphasis on hypertrophic cardiomyopathy. *Circulation*, 91:1596–1601, 1995.
- Maron, B. J., Shirani, J., Poliac, L. C. et al. Sudden death in young competitive athletes: Clinical, demographic and pathological profiles. *JAMA*, 276:199–204, 1996.
- McKenna, W. J., Mogenssen, J., and Elliott, P. M. Role of genotyping in risk factor assessment for sudden death in hypertrophic cardiomyopathy. *J. Am. Coll. Cardiol.*, 39:2049–51, 2002.
- Nishimura, R. A. and Holmes, Jr., D. R. Hypertrophic obstructive cardiomyopathy. *N. Engl. J. Med.*, 350:1320–1327, 2004.
- Scharhag, J., Schneider, G., Urhausen, A. et al. Right and left ventricular mass and function in male endurance athletes and untrained individuals determined by magnetic resonance imaging. *J. Am. Coll. Cardiol.*, 40:1856–63, 2002.
- Sharma, S., Maron, B. J., Whyte, G. et al. Physiologic limits of left ventricular hypertrophy in elite junior athletes: Relevance to differential diagnosis of athlete's heart and hypertrophic cardiomyopathy. *J. Am. Coll. Cardiol.*, 40:1431–6, 2002.

Atrial Fibrillation

- I. Epidemiology
- II. Diagnosis
- III. Causes and Research Implications
- IV. Pathophysiology
- V. Classification and Management
- VI. Anticoagulants
- VII. Electronic Pacing

GLOSSARY

arrhythmia general term for an irregularity or rapidity of the heartbeat, an abnormal heart rhythm.

cardiomyopathy heart muscle disease.

heart failure failure of the heart to pump sufficient blood from the chambers into the aorta; inadequate supply of blood reaches organs and tissues.

myocardial infarction death of an area of heart muscle due to blockage of a coronary artery by blood and atheroma; medical term for a heart attack or coronary thrombosis.

tachycardia increase in heart rate exceeding 100 beats per minute.

torsades de pointes a very serious, life-threatening ventricular arrhythmia.

valvular disorders disease of heart valves, particularly mitral stenosis, mitral regurgitation, aortic stenosis, and aortic regurgitation.

Wolff-Parkinson-White syndrome characterized by premature excitation of the ventricles due to an anomalous conduction bypass tract between the atria and ventricles; often leads to rapid heart rates.

THE TERM ATRIAL FIBRILLATION IS USED TO describe an abnormal rhythm of the heartbeat; instead of beating regularly, the heart beats very erratically. The irregular heartbeats may speed up, and the heart rate may be as fast as 120–180 beats per minute. These fast and strong beats may be sensed as palpitations. Atrial fibrillation is the most common persistent heart rhythm abnormality observed in medical practice.

The adequate management of atrial fibrillation has resisted the major advances in cardiology that have been made in the past 40 years. This stubborn and bothersome arrhythmia has increased to epidemic proportions over the past 20 years, particularly because of an aging population and beneficial treatments for many other heart disease processes that are complicated by atrial fibrillation. The only test available for the diagnosis of atrial fibrillation is the simple, an inexpensive ECG, a clinical test that has remained virtually unchanged since its inception in the 1940s.

Figure 1 shows the electrical system of the heart, the conduction system that transports the current of energy initiated in the sinus node which is then delivered to the ventricular structures to initiate the heartbeat. The ECG picks up the heart's electrical impulses transmitted through the skin of the chest. The normal physiologic process should be understood in order to recognize the clinical features and electrocardiographic findings observed in atrial fibrillation.

The sinoatrial (SA) node is unique and has no steady resting potential. After repolarization, slow spontaneous depolarization occurs. Thus, this unique pacemaker provides individuals with an automatic, infinitesimal current that sets the electrical activity and contraction of the heart. The SA discharge rate, usually 50–100 per minute, is under autonomic, chemical, and hormonal influence.

In the electrical system the atrioventricular (AV) node provides a necessary physiologic delay of the electrical currents. This allows the atria to fill the ventricles with blood before ventricular contraction or systole from the AV node, a physiologic “tollgate,” the electrical current rapidly traverses the right and left bundle branches, the specialized conductive tissues of the ventricles, and the entire ventricular myocardium is depolarized. The transient halt and slowing of conduction through the specialized AV node fibers play an important protective role in patients with atrial flutter and atrial fibrillation. In these conditions, a rapid atrial focus fires at a rate of 300–600 beats per minute and these rapid beats reach the AV node; fortunately, this AV tollgate reduces the electrical

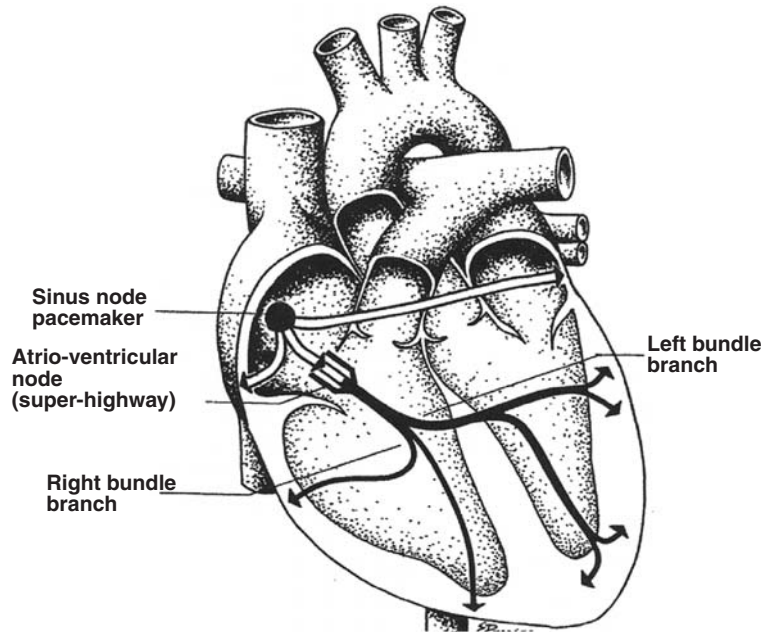

FIGURE I Electrical system of the heart.

traffic that reaches the super highway which traverses the ventricles at approximately 80–180 beats per minute, and serious life-threatening events are prevented as the rapid rates are slowed. (See the chapter Electrocardiography.)

I. EPIDEMIOLOGY

Atrial fibrillation is a common arrhythmia found in greater than 1% of persons older than 60 years. This rate rises to above 5% in people older than 69, and increases to more than 10% in people older than 79. Prevalence of this disorder increases dramatically with age, but it is also becoming more prevalent with time, even after adjustment for age and underlying structural heart disease. More than 85% of patients with atrial fibrillation are older than 65. In the elderly this disorder causes substantial morbidity including stroke, heart failure, and hospitalization. Patients require an anticoagulant to prevent stroke; this therapy occasionally causes cerebral hemorrhage and requires bothersome laboratory testing every 2 weeks.

Younger patients between the ages 25 and 50 are occasionally affected with atrial fibrillation because of the presence of underlying heart diseases that include congenital heart disease, cardiomyopathy, rheumatic heart disease, mitral stenosis, mitral regurgitation, and other valvular disorders. In more than 30% of cases in younger individuals with paroxysmal atrial fibrillation no obvious

structural heart disease was detected on examination of the individual or on tests such as echocardiography and cardiac nuclear scans.

Because of its high prevalence in the worldwide population, hypertension is responsible for more than 14% of cases of heart disease, and it is responsible for more cases of atrial fibrillation than any other disorder. Some patients have atrial fibrillation without evidence of structural heart disease or hypertension; this disorder is labeled lone atrial fibrillation. Data from the Framingham study indicate that lone atrial fibrillation is responsible for greater than 15% of all cases with a peak prevalence in individuals 60–80 years of age.

II. DIAGNOSIS

Diagnosis of atrial fibrillation is based on history, clinical examination, and confirmation with an ECG. The patient may experience rapid and irregular heartbeats usually from one to several hours. Associated symptoms include mild shortness of breath that can become severe if serious underlying heart disease is present. During atrial fibrillation the atrium does not contract normally and blood is therefore not delivered rapidly into the left ventricle. Poor filling of the ventricle and the fast ventricular rate may cause a fall in blood pressure resulting in lightheadedness and dizziness. Because the atrium is fibrillating and not

contracting, there is stasis of blood in the atrial appendage. Stasis predisposes the patient to clot formation and these thrombi may be dislodged and fly into the circulation and travel to other organs (embolize). The embolus can block an artery in the brain and cause a stroke.

Atrial fibrillation may last several hours to a couple of days and then disappear for several days to weeks; this condition is referred to as paroxysmal atrial fibrillation. These patients may have no symptoms from 6 months up to 2 years and then fibrillation may recur. Atrial fibrillation, therefore, does not always cause symptoms and the disease can be misdiagnosed. In the Cardiovascular Health study, 12% of new cases of atrial fibrillation were diagnosed on the basis of ECG screening alone and these individuals presumably had no symptoms.

In patients presenting with atrial fibrillation it is imperative to exclude structural heart disease, particularly

mitral stenosis which has a typical murmur that can be missed because of the fast heart rate. The echocardiogram does not help with diagnosing atrial fibrillation, but it is useful when detecting underlying structural heart disease.

III. CAUSES AND RESEARCH IMPLICATIONS

Diseases or disorders that cause atrial fibrillation are shown in Fig. 2. Due to the vast number of both serious diseases and disorders that cause atrial fibrillation, it is not surprising that a definitive cure is rarely possible. This has become most frustrating for cardiologists and technologists who strive to provide advances in technologic equipment and strategies for the management of atrial fibrillation.

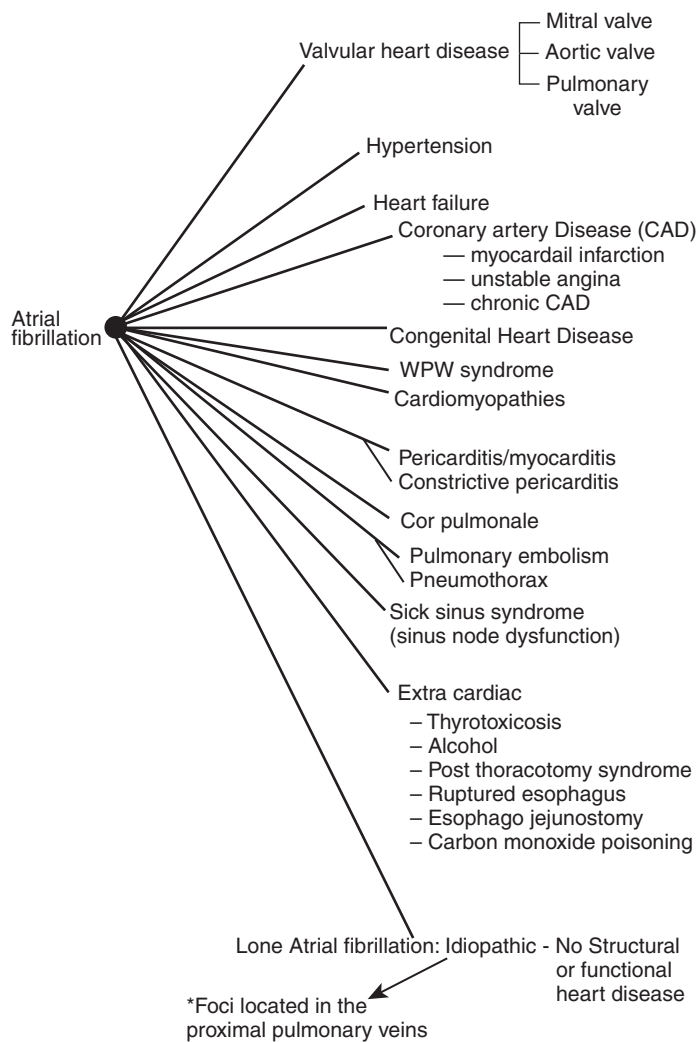

FIGURE 2 Underlying causes or risk factors for atrial fibrillation. *Ablation therapy in patients with paroxysmal atrial fibrillation.

The prevention of atrial fibrillation is therefore of paramount importance. There has been little focus in the past 20 years on the prevention of this abnormality.

A. Hypertension

Because the cure and management of atrial fibrillation is most often difficult, it is necessary to prevent the occurrence of atrial fibrillation by aggressive management of conditions that cause atrial fibrillation. The aggressive management of hypertension is very important. Unfortunately, despite more than 50 years of extensive research by national bodies and pharmaceutical firms and the major advertisement of new drugs available for the management of hypertension, only four antihypertensive agents are available.

These agents include diuretics, beta-blockers, calcium blockers, and ACE inhibitors. The recently added new agents, angiotensin receptor blockers, are really no different from ACE inhibitors but appear to have a lesser incidence of adverse effects. There are more than 12 diuretics, 15 beta-blockers, 10 calcium antagonists, 14 ACE inhibitors, and 6 angiotensin receptor blockers available, but these represent only 4 active agents. In addition diuretics, beta-blockers, or ACE inhibitors achieve the goal blood pressure of less than 140 mmHg in less than 50% of patients. Often two drugs must be used for control, thus reducing patient compliance. Calcium antagonists are effective in approximately 65% of patients, but they are not cardioprotective and carry increased risk for the causation of heart failure in the elderly and in patients with heart disease.

Excellent control of hypertension, therefore, has not been achieved worldwide and this will not occur until the medical profession and pharmaceutical firms recognize the root of the problem. Only four antihypertensive agents are available and they are only mildly beneficial. The fifth group of antihypertensive agents is the alpha-blockers. They have been shown to increase the incidence of heart failure in the recently completed ALLHAT trial. All editorials in clinical medical journals purport the idea that available antihypertensive agents are all beneficial and with combination therapy control is possible.

B. Heart Failure

There is a worldwide epidemic of heart failure. It is caused by most of the conditions listed above, but it has other causes and precipitating factors. Heart failure causes the left atrium to enlarge even further and this enlargement enhances the occurrence of atrial fibrillation. Early

aggressive treatment of mild heart failure, New York Heart Association class I and II, with beta-adrenergic blocking drugs and ACE inhibitors may prevent progression to class III heart failure and may prevent atrial fibrillation in some patients.

C. Valvular Heart Disease

Diseases of heart valves, particularly mitral stenosis, mitral regurgitation, aortic stenosis, and regurgitation, are commonly associated with atrial fibrillation. Many patients following valvular heart surgery develop atrial fibrillation.

D. Chronic Coronary Artery Disease

The prevention of coronary artery disease would obviously lead to a decrease in the prevalence of atrial fibrillation. Atrial fibrillation occurs in more than 15% of patients during the first few days of acute myocardial infarction. Chronic coronary artery disease does not commonly cause atrial fibrillation, but because the disease is common it is responsible for more than 5% of cases of atrial fibrillation. Coronary artery disease is caused by obstruction of arteries by atheroma. After more than 50 years of research it is still impossible to prevent atheroma formation in arteries. Treatment with statins, aspirin, ACE inhibitors, and all the new wonder drugs proclaimed by manufacturers and medical experts only prevent complications of atheroma in approximately 25% of patients, but they do not prevent the disease process. It is obvious that more extensive research is required to halt the epidemic of atheromatous coronary artery disease worldwide (see the chapter Atherosclerosis/Atheroma).

E. Sick Sinus Syndrome

Patients with sick sinus syndrome (sinus node dysfunction) have degenerative disease of the sinus node. The natural generator that emits an electrical impulse causing the heartbeat is diseased in sick sinus syndrome. Bradycardia of less than 45 beats per minute along with greater than 4-second pauses may result in loss of consciousness. In addition, because of the slow heart rate foci in the atrial takeover the electrical circuit and cause rapid heart beats, tachycardia, ranging from 120 to 160 beats per minute. The slow regular rhythm may change to atrial fibrillation often at a fast heart rate, (tachycardia) followed within hours by slow heart rates (bradycardia) — thus the term bradytachy syndrome. These patients are best managed by implantation of a pacemaker.

F. Thyrotoxicosis

Thyrotoxicosis is caused by hyperthyroidism. The thyroid glands produce excessive amounts of thyroxine with resultant stimulation of the heart and tachycardia. Atrial fibrillation is a well-known complication and bothersome palpitations with tachycardia of 120–180 beats per minute may occur. The tachycardia is controlled with beta-blocking drugs such as propranolol, and the thyroid gland is treated with medications or radioactive iodine.

G. Idiopathic Atrial Fibrillation

It is not uncommon for atrial fibrillation to occur in the absence of an abnormal structural or functioning heart. This condition is called lone atrial fibrillation. Data from various countries are not available, but in the United States approximately 15% of patients are found to have lone atrial fibrillation. In some of these patients, and particularly in those with paroxysmal atrial fibrillation, recent investigations have revealed foci located in the proximal pulmonary veins that may cause ectopic atrial activation.

IV. PATHOPHYSIOLOGY

During the past 50 years different theories have been proposed to explain the mechanism underlying atrial fibrillation, but many controversies surrounded these mechanisms. In the past decade it seems well accepted that both focal and reentrant mechanisms are involved, playing a different role in the initiation and perpetuation of the arrhythmia. Several recent human multielectrode mapping systems and other studies indicate that in atrial fibrillation the dominant mechanism incorporates multiple meandering wavelets, both in the acute and chronic form of this condition. Multiple wavelengths of excitation propagate around the atrial myocardium and the arrhythmia is perpetuated because of an abnormal atrial tissue substrate, particularly in patients with structural heart disease and permanent atrial fibrillation. Patients with paroxysmal atrial fibrillation with no evidence of structural heart disease appear to have a trigger-predominant mechanism, but the two basic mechanisms reflect a large overlap. After very long periods of permanent atrial fibrillation, if sinus rhythm is restored, reverse remodeling usually fails to occur. This may explain why in patients with persistent atrial fibrillation for more than 12 months it is difficult to maintain sinus rhythm following cardioversion.

Atrial fibrillation may be triggered by focal initiators. Recent experimental work indicates that ectopic atrial activation may emerge from one or more foci located in the muscular sleeves of the proximal pulmonary veins as single beats or repetitive bursts of activity. This focal-triggered atrial fibrillation is often paroxysmal in its early stages, and it may be observed in individuals with structurally normal hearts. The focal-triggered mechanism may also underlie some cases of persistent atrial fibrillation in the presence or absence of structural heart disease. It appears that the presence of atrial foci functioning as triggers localized in the pulmonary veins is a finding in many patients with lone or idiopathic and paroxysmal atrial fibrillation. In this group of patients, segmental or circumferential pulmonary vein ablation has an emerging role.

V. CLASSIFICATION AND MANAGEMENT

A. Acute Atrial Fibrillation

An episode of atrial fibrillation observed within 48 h of its onset is described as acute. If the ventricular rate is greater than 160 beats per minute and results in acute cardiovascular decompensation manifested by hypotension, shortness of breath, chest pain, confusion, or heart failure, the rhythm should be converted to normal sinus rhythm. DC cardioversion is usually the initial treatment of choice.

Figure 3A shows the ECG tracing of a patient with acute atrial fibrillation and a fast ventricular rate of 160 beats per minute. Figure 3B shows the same patient hours later after the rate had been decreased by a beta-blocking drug. It also shows spontaneous reversion to normal sinus rhythm. The diagnostic points of the ECG are as follows: the rhythm is completely irregular, the R-to-R intervals are irregular, there are no visible P-waves, and the baseline shows irregular undulations.

If there are no signs of cardiovascular decompensation and the arrhythmia is well-tolerated, diltiazem (a calcium antagonist), esmolol, or other beta-blocking drugs administered intravenously can be used to slow the ventricular response to less than 110 beats per minute, with the hope that normal sinus rhythm may return spontaneously within 12–24 h of onset. Sinus rhythm may return spontaneously if atrial fibrillation is due to an extracardiac cause that is corrected or if the left atrium is not enlarged. If spontaneous sinus rhythm does not occur, conversion to sinus rhythm may be attempted with pharmacologic agents such as ibutilide.

Ibutilide should not be used in patients with a low serum potassium level or prolonged QT interval because torsades de pointes may be precipitated. There is a 5%

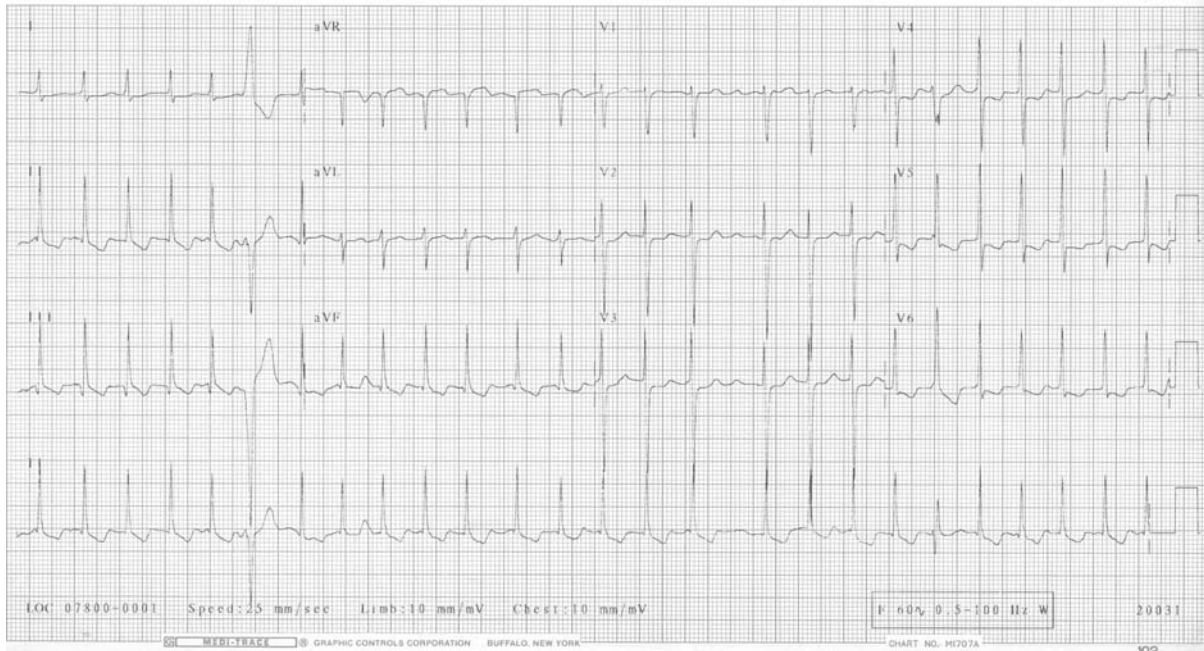

FIGURE 3A Atrial fibrillation; fast ventricular rate 165 beats per minute.

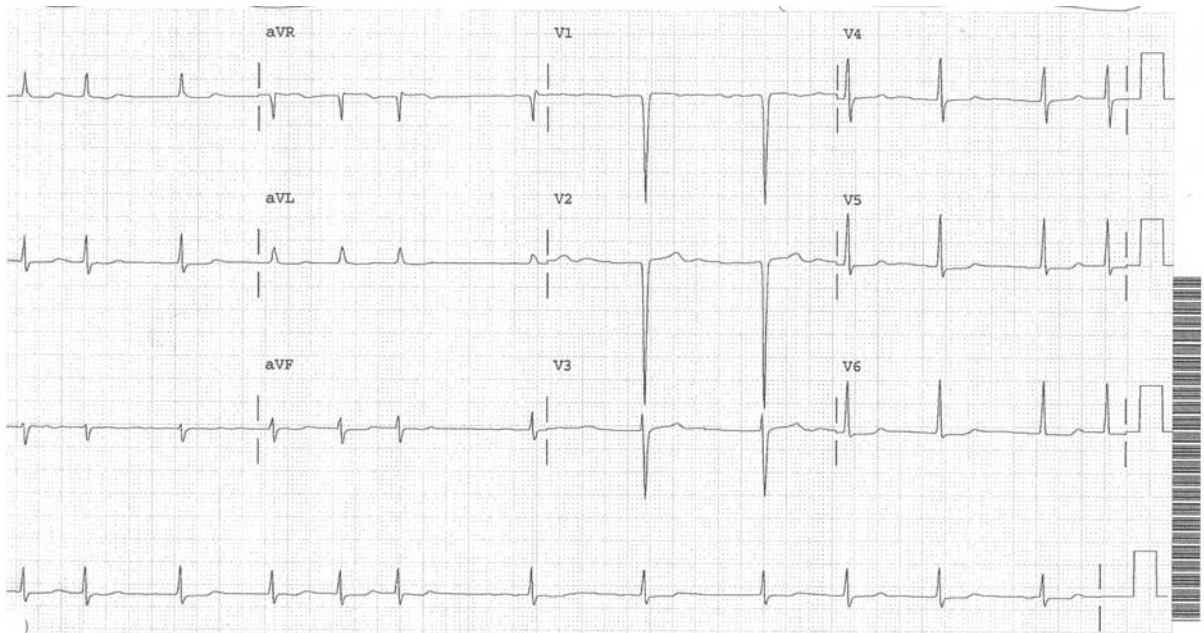

FIGURE 3B Atrial fibrillation. Note the completely irregular rhythm, RR intervals irregular, absent P waves; slow ventricular response of 80 beats per minute.

incidence of torsades in patients with ischemic heart disease. This drug should not be used concomitantly with drugs that increase the QT interval.

Patients with atrial fibrillation for more than 48 h require oral anticoagulation with warfarin for at least 3 weeks before cardioversion can be safely attempted.

Anticoagulants are continued after conversion for at least 8 weeks to prevent thromboembolism and stroke. Alternatively heparin is administered intravenously, and if no thrombi are observed by transesophageal echocardiographic assessment, cardioversion may be attempted if deemed absolutely necessary.

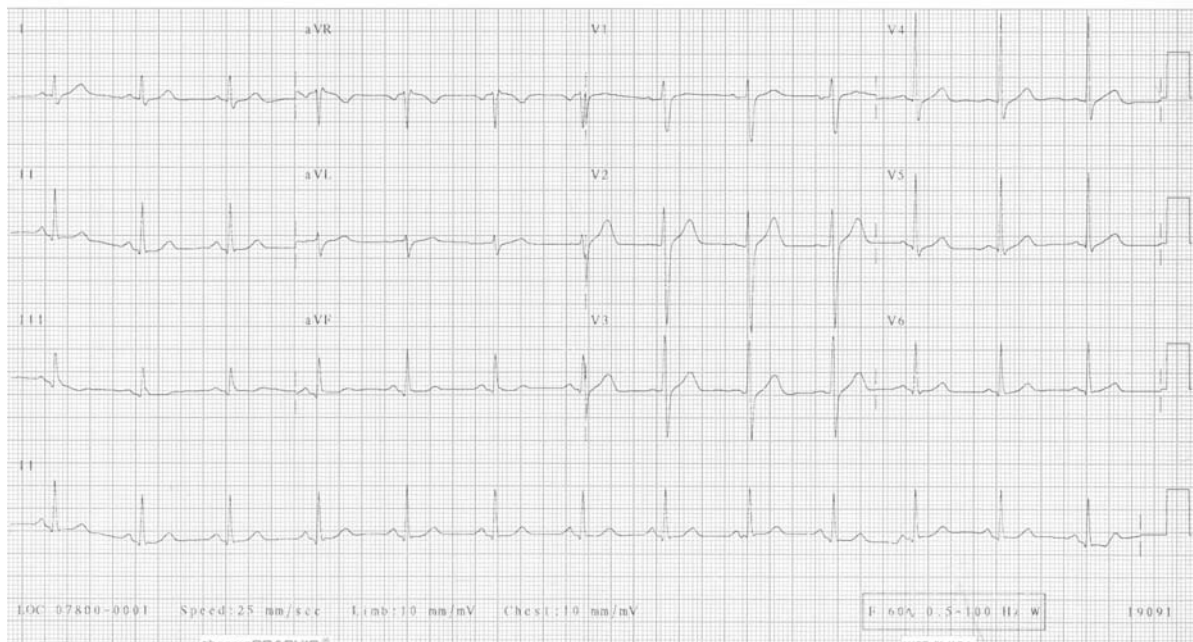

FIGURE 3C Normal ECG: normal RR intervals, regular sinus rhythm, P waves visible.

If there is no hemodynamic compromise and the patient is stable in the presence of acute atrial fibrillation, the reasons for conversion to sinus rhythm should be strongly examined. Although electrical cardioversion may establish sinus rhythm in more than 90% of patients, after 6 months less than 30% of patients remain in sinus rhythm.

If atrial fibrillation occurs with very fast heart rates of 200–240 per minute, Wolff-Parkinson-White syndrome may be the underlying cause. This disease is caused by an anomalous pathway that is capable of conducting rapidly. Drugs that are commonly used to manage chronic atrial fibrillation such as digoxin, beta-blockers, and calcium antagonists are contraindicated (see Wolff-Parkinson-White syndrome in the glossary).

B. Paroxysmal Atrial Fibrillation

These patients experience intermittent, recurrent, and self-terminating episodes of atrial fibrillation. Episodes are considered paroxysmal atrial fibrillation if they terminate spontaneously. Some patients tolerate these short bouts of irregular, abnormal heart rhythms without symptoms, especially if they are in the range of 100–140 beats per minute. Many elderly patients tolerate atrial fibrillation well without therapy or with minimum therapy, because the ventricular rate is slow (80–120 beats per minute) and because they have concomitant atrioventricular (AV) nodal disease. AV nodal disease blocks conduction from the

atrium to the ventricle slowing the ventricular response and heart rate. This slow ventricular response happens because several of the drugs used (digoxin, beta-blockers, calcium antagonists) to control the fast heart rates cause a partial blockage of the electrical impulse as it traverses the AV node to reach the ventricle (see Fig. 1).

Other patients experience rapid heart rates of 160–190 beats per minute that may recur twice a year or two or three times weekly for a few months then recur months later. Paroxysmal atrial fibrillation of this type is extremely bothersome to many patients who may have to attend emergency rooms or must receive antiarrhythmic drugs or pacemaker therapy.

Paroxysmal atrial fibrillation accounts for 35–50% of all cases of atrial fibrillation. It is most common in patients in their 50s and 60s with prevalence peaking between the ages of 50 and 70. This condition is three times more common in men than in women. The probability that lone atrial fibrillation will progress from paroxysmal to permanent is approximately 20%. Paroxysmal atrial fibrillation occurs in patients with structurally normal hearts, but it also occurs in patients with structural heart disease.

Paroxysmal atrial fibrillation remains a difficult problem to manage. The rapid heart rates are difficult to control with available agents, which include beta-blockers, calcium antagonists, digoxin, and amiodarone. Sotalol 160–240 mg daily may cause maintenance of sinus rhythm in less than 50% of patients. Breakthrough atrial fibrillation commonly occurs and anticoagulation with warfarin or

ximelagatran becomes necessary to prevent stroke (see the chapter Blood Clots).

Paroxysms with a ventricular rate of 140–180 beats per minute can be managed with diltiazem or esmolol intravenously to reduce the rapid heart rate to less than 110 beats minute until spontaneous revision to sinus rhythm occurs. Digoxin is usually not effective in reducing rapid ventricular rates during paroxysms and is not advisable in patients with paroxysmal atrial fibrillation except when combined with a beta-blocking drug. The combination of a beta-blocking drug with the calcium blocker diltiazem plays a role in controlling rapid ventricular rates.

In patients with paroxysmal atrial fibrillation resistant to drug therapy there are three options: Complications of these procedures must be outlined in detail to the patient.

1. Pulmonary Vein Ablation

In pulmonary vein ablation percutaneous catheters are used to identify the location of arrhythmogenic foci within all four pulmonary veins. Either segmental pulmonary vein isolation or circumferential pulmonary vein ablation techniques are used at different centers. In skilled hands and in patients with one focus, the success rate approaches 80%. The success rate is low in patients with persistent atrial fibrillation and lower in those with structural heart disease than in those without. Left atrial ablation to encircle the pulmonary veins has been shown to improve survival, reduce the risk of heart failure and stroke, and improve quality of life when compared with medical therapy.

Patients not suitable for pulmonary vein ablation include those with a large left atrium of greater than 60 mm, patients with contraindications to anticoagulants, and the elderly over 75 years of age. Before considering pulmonary vein ablation, sinus node dysfunction (sick sinus syndrome), thyrotoxicosis, AV nodal reentrant tachycardia, and Wolff-Parkinson-White syndrome must be excluded.

a. Clinical Studies

In a published series (San Raffaele University Hospital, Milan, Italy), 251 patients underwent circumferential pulmonary vein ablation: 179 patients with paroxysmal atrial fibrillation and 72 patients with persistent atrial fibrillation present for more than 3 months. At a mean follow up of 310 days, 86% of the patients with paroxysmal atrial fibrillation and 76% of patients with chronic atrial

fibrillation, respectively, were free of recurrent atrial fibrillation in the absence of antiarrhythmic drugs.

In a study from the University of Michigan (Ann Arbor), segmental pulmonary vein isolation was performed in 93 patients with paroxysmal atrial fibrillation and 17 with persistent atrial fibrillation. At a mean follow up of 208 days 28 and 70% of the paroxysmal and persistent atrial fibrillation patients, respectively, experienced recurrent episodes of symptomatic fibrillation in the first 2 weeks after ablation. The only independent clinical predictor of the ablation was the presence of persistent atrial fibrillation before the procedure.

Good clinical results were achieved in patients with valvular disease, cardiomyopathy, and coronary artery disease with or without left ventricle dysfunction. Because of these encouraging results, an algorithm has been proposed by the American Heart Association/American College of Cardiology, see Fig. 4.

2. Specific Linear Left Atrial Lesions

a. Clinical study, Kottkamp et al.

Study question: Curative treatment for patients with refractory atrial fibrillation is among the main challenges of interventional electrophysiology. A specific left atrial linear lesion concept for treatment of paroxysmal and permanent atrial fibrillation was tested using intraoperative ablation with minimally invasive surgical techniques.

Method: Seventy patients with drug-refractory persistent and paroxysmal atrial fibrillation underwent intraoperative radiofrequency ablation using video-assisted minimally invasive techniques via minithoracotomy.

Results: Mean follow up was 18 months. Six months following ablation, 93% of patients were in sinus rhythm in both groups and at 12 months 96% were in sinus rhythm.

Conclusions: A pure linear lesion line concept confined to the left atrium specifically targeting elimination of anatomically defined left atrial “anchor” reentrant circuits eliminated atrial fibrillation over a mean follow up of 18 months in greater than 90% of patients.

Research implication: The linear lesion line concept is not yet practicable when applied percutaneously. The pathophysiologic concept is the prevention of anatomically defined left atrial reentrant circuits without mass reduction and without treatment of potential triggers. It is possible that in the future this intraoperatively validated strategic linear left atrial lesion line concept might be transferred to catheter ablation; new navigation and catheter technologies should allow the transfer to percutaneous ablation techniques.

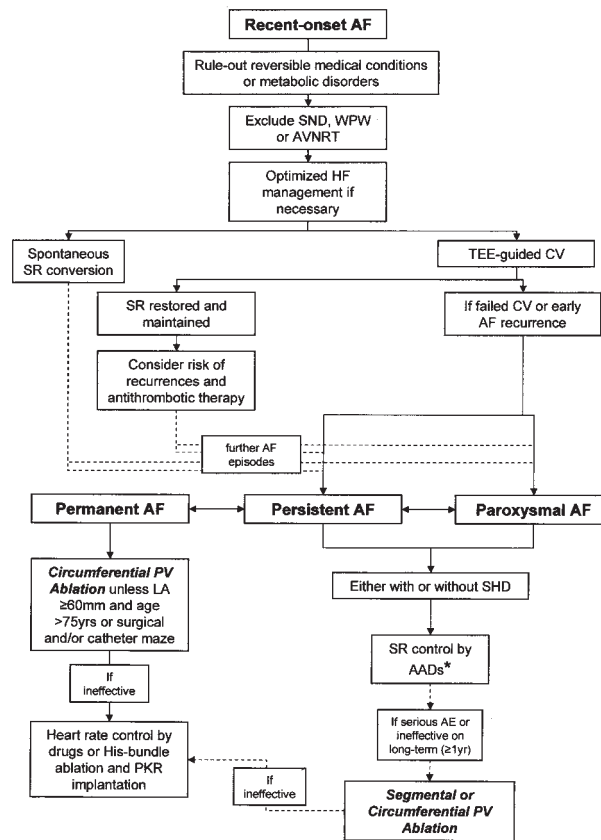

FIGURE 4 Algorithm for the management of atrial fibrillation based on its clinical presentation. AF = atrial fibrillation; SND = sinus node dysfunction; WPW = Wolff-Parkinson-White syndrome; AVNRT = atrioventricular nodal reentrant tachycardia; HF = heart failure; SR = sinus rhythm; TEE = transesophageal echocardiography; CV = electrical and/or pharmacological cardioversion; PV = pulmonary vein; LA = left atrium; LV = left ventricular; SHD = structural heart disease; AADs = antiarrhythmic drugs; AE = adverse events; PKR = pacemaker. *According to the American Heart Association/American College Cardiology guidelines. (From (2003). *ACC Curr. J. Rev.* with permission from the American College of Cardiology Foundation.)

C. Persistent Atrial Fibrillation

This form of atrial fibrillation will not self-terminate, but it can be effectively cardioverted to sinus rhythm with DC cardioversion or pharmacologic agents. Some patients with valvular heart disease may be converted easily provided that the left atrium is not large. A large left atrium greater than 5 cm is a risk factor for the causation of atrial fibrillation and often predicts a recurrence in a few months following cardioversion to sinus rhythm.

A major randomized clinical trial involving more than 4500 patients, randomized to either rate control of persistent atrial fibrillation or rhythm control (suppression of atrial fibrillation), showed no significant differences in mortality, morbidity, or quality of life between the two strategies.

Patients with drug-refractory persistent atrial fibrillation may require intervention that includes pulmonary vein ablation or intraoperative radiofrequency ablation

utilizing a specific left atrial linear lesion line concept, as described above.

I. Synchronized DC Cardioversion

Attempting DC conversion of atrial fibrillation is always considered carefully. Immediate DC cardioversion is indicated for patients who are hemodynamically unstable. It is usually contraindicated in permanent atrial fibrillation with a duration of greater than one year because sinus rhythm is usually not maintained and in patients with a left atrial size greater than 5.5 cm. Patients with atrial fibrillation of less than one week's duration usually regain atrial function after conversion. Embolization occurs in about 2% of patients and anticoagulation is necessary before cardioversion. Conversion should not be attempted in patients with suspected digitalis toxicity because of the risk of precipitating ventricular fibrillation. Patients with

sick sinus syndrome (sinus node dysfunction) should not be considered as conversion may cause prolonged pauses. Anticoagulants are not used in DC conversion if the atrial fibrillation has been present for less than 24 h; patients with valvular heart disease, particularly mitral stenosis, may have thrombus in the left atrial appendage and transesophageal echocardiography is warranted to exclude thrombi. In patients with a duration over 24 h but less than 48 h, IV heparin may be used for anticoagulation to allow conversion within 24 h. Patients with atrial fibrillation for greater than 48 h should be anticoagulated for at least 3 weeks prior to conversion and anticoagulation should be continued for more than three weeks following conversion. Light anesthesia with a standby anesthesiologist is necessary during the procedure.

D. Permanent Atrial Fibrillation

Atrial fibrillation that cannot be terminated by cardioversion, that can be terminated only for brief intervals, or that lasts longer than one year without cardioversion having been attempted is classified as permanent. Chronic atrial fibrillation implies continuing atrial fibrillation and does not address the important clinical distinction between persistent and permanent atrial fibrillation.

In the vast majority of patients with permanent atrial fibrillation, slowing of the ventricular response to 70–90 beats per minute will be helpful. A beta-blocking drug such as metoprolol, bisoprolol, or atenolol should slow down the ventricular response. These agents are also a good choice in patients with concomitant congestive heart failure New York heart Association class I–III. Digoxin was commonly used for this condition from the 1950s to 1990, but during the past decade beta-blockers have become the agents of choice, mainly because it became apparent that digoxin does not achieve the control of a fast ventricular rate associated with exercise. In patients in whom beta-blockers cannot be used safely, the ventricular rate can be slowed sufficiently with the inexpensive digoxin administered once daily. Occasionally a combination of a beta-blocker and digoxin becomes necessary.

All of the available beta-blocking drugs can be used safely with the exception of sotalol. This drug must not be used in the management of permanent (chronic) atrial fibrillation because it carries a risk of torsades de pointes. Other beta-blockers do not have this adverse side effect.

A recent clinical trial confirmed that it is safer to manage patients with permanent atrial fibrillation by controlling their ventricular rate (heart rate) rather than attempting to cardiovert to sinus rhythm or use pharmacologic agents to maintain sinus rhythm. Patients after conversion do not

often remain in sinus rhythm and pharmacologic agents (amiodarone, flecainide, propafenone, sotalol, and quinidine) necessary to maintain sinus rhythm are usually not successful and produce life-threatening adverse effects.

VI. ANTICOAGULANTS

A. Warfarin

Patients with atrial fibrillation considered high risk for stroke require anticoagulation with warfarin to maintain an INR of 2–3 to prevent stroke. An INR of 1.4–1.9 has been shown to be associated with a stroke or mortality rate similar to that for an INR of less than 1.5. The loss of atrial contraction leads to stasis of blood in the atrium and is more marked in the left atrial appendage, the most common site for clot formation. Stasis is accompanied by hypercoagulability and there is increased concentrations of fibrinogen and fibrin D-dimer and increased concentrations of von Willebrand factor. These derangements all contribute to the development of a prothrombotic state and embolization. Five randomized clinical trials indicate that warfarin anticoagulation reduces the risk of stroke by 68% and lowers mortality by 33%. The risk of hemorrhagic complications, particularly cerebral hemorrhage, rises greatly when the INR exceeds 3.9. Patients on oral anticoagulants should have blood tests every 2–3 weeks to maintain an INR of 2–3 in order to prevent serious hemorrhagic events. In patients over 80 years of age and in those with small risk of bleeding, the INR is maintained at 1.8–2.8. Patients at high risk for bleeding are not given anticoagulants.

Aspirin is only recommended for patients with lone atrial fibrillation who are younger than 65 and with no other risk factors for thromboembolism and for those who are intolerant to warfarin administration. Aspirin's risk reduction of stroke is less than 20%. Patients with lone atrial fibrillation who are younger than 65 have a low stroke rate of approximately 1% versus patients over age 75 with one or more additional risk factors for thromboembolism who have a stroke rate of greater than 8%. Lone atrial fibrillation is indicated by the absence of hypertension and valvular and other heart disease.

B. New Anticoagulant: Ximelagatran

This direct thrombin inhibitor has been shown to be as effective as warfarin in preventing stroke and does not require monitoring with blood tests. The drug represents a major breakthrough for management of atrial fibrillation

and control of thromboembolism. The stroke prevention with the oral direct thrombin inhibitor ximelagatran, compared with warfarin in patients with nonvalvular atrial fibrillation (SPORTIF III and V randomized trials, studied patients at moderate risk. Patients with mitral stenosis, significant valve disease, or previous valvular heart surgery were excluded. Thus the new agent if approved should be used only in patients similar to those in the SPORTIF trials. *Caution:* in both trials the new drug caused substantial but usually transient increases in liver enzyme concentrations in 6% of patients. Enzyme elevations reached greater than five times the upper limits of normal in 3.4% of ximelagatran-treated patients (see the chapter Blood Clots). Hepatotoxicity limits the use of the drug and similar agents should be sought.

VII. ELECTRONIC PACING

It is known that conversion of atrial fibrillation to sinus rhythm does not improve survival. The reason for trying to maintain sinus rhythm is mainly to control symptoms. Neither antiarrhythmic drugs nor atrial pacing alone have been successful in suppressing atrial fibrillation.

A. Atrial Pacing

Recently, dual-site right atrial pacing has been shown in small studies to achieve partial suppression of arrhythmia in patients with bradycardia and atrial fibrillation on antiarrhythmic drugs. The trials, however, do not support the use of atrial pacing as monotherapy in symptomatic atrial fibrillation.

B. Ablation of the AV node and Implantation of a Permanent Pacemaker

This procedure is a last resort for patients with bothersome atrial fibrillation refractory to other treatments. The ablation of the AV node produces rate control and regular ventricular contractions, but the atria continue to fibrillate and the risk of stroke remains. Mortality is not improved by this procedure. The combined incidence rate of sudden death and malignant ventricular arrhythmias is approximately 7%.

I. Clinical Study, Ozcan et al.

In a study of 334 consecutive patients with atrial fibrillation who underwent AV node ablation, 9 patients had sudden death after the ablation, 4 patients had sudden

death likely related to the procedure, and in 3 patients arrest occurred within 48 h and 1 patient arrested 4 days after the procedure. In three other patients sudden death was possibly related to the procedure, because the event occurred within 3 months afterward.

The risk of sudden death is highest within 2 days after procedure. The annual rate of sudden death ranges from 2 to 4%. The high risk of death is unacceptable in a condition that does not cause sudden death and in which mortality is low in patients treated with anticoagulants.

BIBLIOGRAPHY

- ALLHAT: Major outcomes in high-risk hypertensive patients randomized to angiotensin converting enzyme inhibitor or calcium channel blocker versus diuretic; the antihypertensive and lipid lowering treatment to prevent heart attack trial. *JAMA*, 288:2981–97, 2002.
- Alboni, P., Bott, G. L., Bald, N. et al. Outpatient treatment of recent-onset atrial fibrillation with the "Pill-in-the-Pocket" approach. *N. Engl. J. Med.*, 351:2384–2391, 2004.
- Bourassa, M. G. et al. Angiotensin II inhibition and prevention of atrial fibrillation and stroke. *J. Am. Coll. Cardiol.*, 45:720–721, 2005.
- Executive Steering Committee on Behalf of the SPORTIF III Investigators. Stroke prevention with the oral direct thrombin inhibitor ximelagatran compared with warfarin in patients with nonvalvular atrial fibrillation (SPORTIF III), a randomized controlled trial. *Lancet*, 362:1691–1698, 2003.
- Gaita, F., and Riccardi, R. Lone atrial fibrillation; transcatheter or minimally invasive surgical approaches? *J. Am. Coll. Cardiol.*, 40: 481–83, 2002.
- Gaita, F., Riccardi, R., Caponi, D. et al. Linear cryo-ablation of the left atrium versus pulmonary vein cryo-isolation in patients with permanent atrial fibrillation and valvular heart disease: Correlation of electroanatomic mapping and long-term clinical results. *Circulation*, 111:136–142, 2005.
- Halperin, J. L. et al. Ximelagatran: Oral direct thrombin inhibition as anticoagulant therapy in atrial fibrillation. *J. Am. Coll. Cardiol.*, 45:1–9, 2005.
- Hazel, S. J., Paterson, H. S., Edwards, J. R. M. et al. Treatment of atrial fibrillation via energy ablation. *Circulation*, 111:e103–e106, 2005.
- Hylek, E. M., Go, A. S., Chang, Y. et al. Effect of intensity of oral anticoagulation on stroke severity and mortality in atrial fibrillation. *N. Engl. J. Med.*, 349:1019–26, 2003.
- Jongbloed, M. R. M., Bax, J. J., Lamb, H. J. et al. Multi-slice computed tomography versus intra-cardiac echocardiography to evaluate the pulmonary veins before radiofrequency catheter ablation of atrial fibrillation. *J. Am. Coll. Cardiol.*, 45:343–350, 2005.
- Khan, M. Gabriel. Arrhythmias. In *Cardiac Drug Therapy*, sixth edition, W. B. Saunders, Philadelphia, 2003.
- Kottkamp, H., Hindricks, G., Autschbach, R. et al. Specific linear left atrial lesions in atrial fibrillation. *J. Am. Coll. Cardiol.*, 40:475–80, 2002.
- Lauer, M. R. Dofetilide: Is the treatment worse than the disease? *J. Am. Coll. Cardiol.*, 37:1106–10, 2001.
- Marza, I., James, S., and Holt, P. Bialtrial pacing for paroxysmal atrial fibrillation. *J. Am. Coll. Cardiol.*, 40:457–63, 2002.
- Montenero, A. S., Bruno, N., Antonelli, A. et al. Long-term efficacy of cryo catheter ablation for the treatment of atrial flutter. *J. Am. Coll. Cardiol.*, 45:573–580, 2005.

- Ozcan, C., Jahangir, A., Friedman, P. A. et al. Sudden death after radiofrequency ablation of the atrioventricular node in patients with atrial fibrillation. *J. Am. Coll. Cardiol.*, 40:105–10, 2002.
- Pappone, C., Rosanio, S., Augello, G. et al. Morbidity and mortality and quality of life after circumferential pulmonary vein ablation for atrial fibrillation. *J. Am. Coll. Cardiol.*, 42:185–197, 2003.
- Packer, D. L., Keelan, P., Munger, T. M. et al. Clinical presentation, investigation, and management of pulmonary vein stenosis complicating ablation for atrial fibrillation. *Circulation*, 111:546–554, 2005.
- Page, R. L. et al. Newly diagnosed atrial fibrillation. *N. Engl. J. Med.*, 351:2408–2416, 2004.
- Peters, N. S., Schilling, R. J., Kanagaratnam, P. et al. Atrial fibrillation: Strategies to control, combat, and cure. *Lancet*, 359:593–603, 2002.
- Saksena, S., Prakash, A., Ziegler, P. et al. Improved suppression of recurrent atrial fibrillation with dual site right atrial pacing and antiarrhythmic drug therapy. *J. Am. Coll. Cardiol.*, 40:1140–50, 2002.
- Wachtell, K., Hornestam, B., Lehto, M. et al. Cardiovascular morbidity and mortality in hypertensive patients with a history of atrial fibrillation. *J. Am. Coll. Cardiol.*, 45:705–711, 2005.

Atrial Septal Defect

I. Clinical Study

GLOSSARY

embolization encrusted material, particularly small clots or bacterial vegetation on the heart valves, heart chambers, or veins which may dislodge and fly off into the circulation; they are swiftly carried to other organs, for example, pulmonary embolism.

murmur a blowing sound heard with a stethoscope usually caused by obstruction of heart valves or leaking valves.

ATRIAL SEPTAL DEFECT, A HOLE IN THE SEPTUM dividing the right and left atrium, is the most common congenital heart defect observed after age 12 and in adults, because the lesion is usually so small that it causes little disturbance in infants. Atrial septal defect accounts for approximately 10% of all congenital cardiac defects. With this defect oxygenated blood is shunted from the left atrium into the right atrium and traverses the pulmonary arteries and lungs and returns to the left side of the heart (Fig. 1). This circulatory disturbance is called a left to right shunt. The shunt is usually small but if the hole is large enough the right ventricle works harder to pump the extra blood delivered to it, from the left side, into the pulmonary arteries and through the pulmonary circulation back to the left side of the heart. The right ventricle over time is subjected to more strenuous work than normal. The muscle of the right ventricle becomes weaker and fails to expel sufficient blood from the chamber, and a condition referred to as right heart failure occurs. The atrial septal defect most often involves the fossa ovalis in the mid septal region; this is called an ostium secundum type of defect.

With a small hole in the heart, the infant or young child is relatively asymptomatic. With larger defects tiredness, shortness of breath on exertion, and frequent infection of the lungs may occur. These symptoms are more obvious as heart failure worsens. A soft heart murmur is usually heard

which leads to further investigations. Because oxygenated blood is pumped from the left atrium into the right side of the heart, the organs of the body including the skin receive oxygenated blood. Thus, the individual does not become blue in the face, a condition described as cyanosis. Because of this, atrial septal defect is a cause of noncyanotic congenital heart disease.

The ECG usually shows evidence of an incomplete right bundle branch block. This is a clue for the treating physician. A transesophageal echocardiogram (TEE) is usually diagnostic. Closure of the hole in the heart is curative and should be done if symptoms are present.

I. CLINICAL STUDY

Study question: A study by Attie et al. assessed whether surgical treatment of atrial septal defects in patients over age 40 improves their long-term outcome.

Methods: The study included 521 patients over age 40 with atrial septal defect who were randomly assigned to surgical closure or medical treatment.

Results: After approximately seven years of follow-up, surgical closure was superior to medical treatment in improving the composition of major cardiovascular events and overall mortality. Closure of the defect is advisable in patients over age 40 with pulmonary artery pressures less than 70 mmHg and a pulmonary/systemic output ratio greater than 1.7. Sudden death was more common in the medical group than the surgical group. This study shows that nonsurgical closure of the defect is not an option.

A nonrandomized analysis of 442 patients undergoing closure with the Amplatzer septal occluder (ASO) was compared with 154 patients in the surgical group. The ASO consists of two expandable round disks with a 4 mm long connecting waist that is delivered to the site in the left atrium via a catheter threaded through the left upper pulmonary vein. The early primary and secondary benefits for surgical versus device closure were not significantly different. The complication rate, however, was lower and hospital stay was shorter for device closure versus surgical

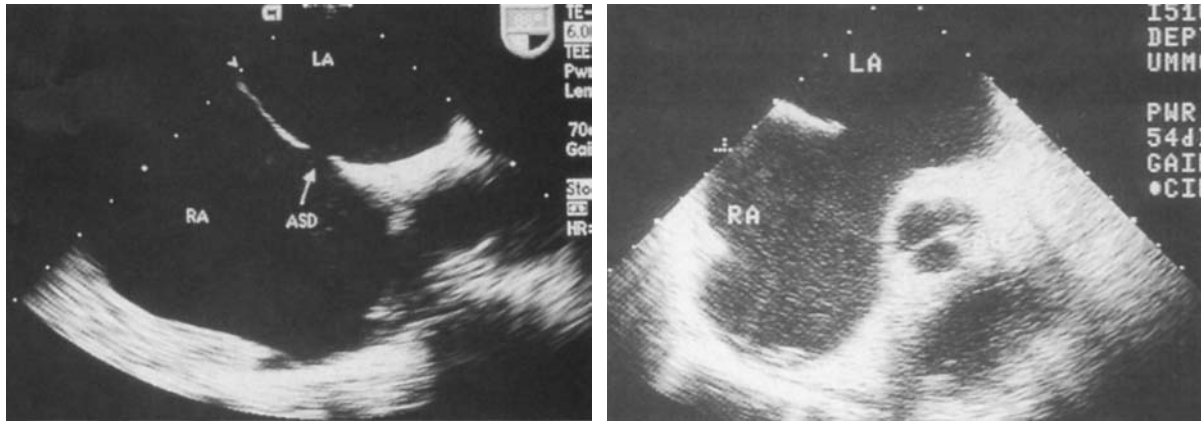

FIGURE 1 Transesophageal echocardiograms in two patients with atrial septal defects. In each case there is a distinct loss of tissue in the atrial septum, allowing direct communication between the left atrium and right atrium. (From Braunwald, E., *Heart Disease. A Textbook of Cardiovascular Medicine*, sixth edition, Philadelphia: W. B. Saunders, 197, 2001.)

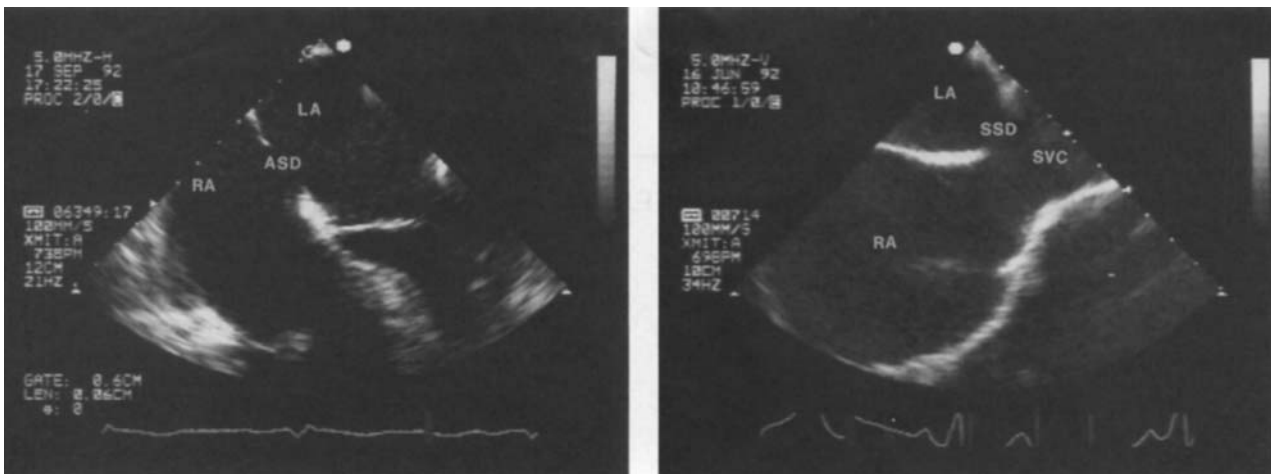

FIGURE 2 Transesophageal two-dimensional images from patients with an ostium secundum (A) and superior sinus (B) atrial septal defect. In (A) the defect is seen in the mid-portion of the inter-atrial septum in the fossa ovalis. In (B) the superior sinus defect (SSD) can be seen to be an 'overriding' of the superior vena cava (SVC) rather than a defect in the inter-atrial septum itself. (From Camm, J.D., Fox, A.J., Hall, R.J.C., and Poole-Wilson, P.A., Eds., *Diseases of the Heart*, second edition. London: W. B. Saunders, 327, 1996.)

repair. The complication rate was 7.2% for the device group and 24% for the surgical group.

In a 417-patient study by Chessa et al., the CardioSEAL/STARFlex was used in 159 patients and the ASO in 258 patients. Thirty-four patients experienced 36 complications. Ten patients underwent elective surgical repair because of device malposition or embolization. Twenty-four patients experienced 25 minor complications, unsatisfactory device position, or embolization. One patient had peripheral embolization one year after implantation and sudden death occurred in one patient 1.5 years later. The authors of the study concluded that the ASO device became their first choice for closing defects larger than 18 mm. Transcatheter closure of the hole in the atrial septum has evolved successfully over the past 20 years, but

appropriate patient selection and expertise for deployment of the seal is crucial.

BIBLIOGRAPHY

- Attie, F., Rosas, M., Granados, N. et al. Surgical treatment for secundum atrial septal defects in patients greater than 40 years old. *J. Am. Coll. Cardiol.*, 58: 2035-4, 2001.
- Chessa, M., Carminati, B., Margherita, B. et al. Early and late complications associated with transcatheter occlusion of secundum atrial septal defect. *J. Am. Coll. Cardiol.*, 39:1061-5, 2002.
- Du, Z.-D., Hijazi, Z. M., Kleinmann, C. S. et al. Comparison between transcatheter and surgical closure of secundum atrial septal defect in children and adults. *J. Am. Coll. Cardiol.*, 39:1836-44, 2002.
- Roman, K. S., Masaki, N., Fraser, G. et al. Real-time subcostal 3-dimensional echocardiography for guided percutaneous atrial septal defect closure. *Circulation*, 109:320-321, 2004.

B-Type Natriuretic Peptide

- I. Clinical Studies
- II. Perspective

GLOSSARY

- heart failure** a failure of the heart to pump sufficient blood from the chambers into the aorta; inadequate supply of blood reaches organs and tissues.
- dyspnea** shortness of breath, usually on exertion.
- edema** accumulation of fluid
- myocardium** the heart muscle.

THE NATRIURETIC PEPTIDE SYSTEM INCLUDES atrial (ANP) and brain or B-type (BNP) natriuretic peptide. Brain natriuretic peptide (BNP) is a 32 amino acid cardiac natriuretic peptide that was originally isolated from porcine brain tissue. The human BNP gene is located on chromosome 1 and encodes the 108 amino acid prohormone pro-BNP which circulates with the 32 amino acid biologically active BNP and the N terminal 76 amino acid component of the prohormone (NT-proBNP). These three components can be measured by immunoassay.

BNP is released by cardiac myocytes of the ventricles in response to myocardial wall stress. This is brought on by increased transmural wall tension and elevations of end diastolic pressure, ventricular volume expansion and pressure overload. The secretion of this important peptide serves to regulate sodium and water balance by the kidneys and causes vasodilatation of arteries, which benefits the failing heart.

Elevated BNP levels are detected in the blood of patients with heart failure but levels are normal in patients with shortness of breath caused by pulmonary disease. The rapid measurement of levels of BNP in the blood has proved useful in the diagnosis of heart failure. More important, in emergency rooms the BNP test rapidly clarifies whether severe shortness of breath is caused by heart failure or by pulmonary disease. Heart

failure is readily diagnosed by the symptoms of severe shortness of breath on minimal effort, shortness of breath in bed, and swelling of the ankles caused by accumulation of fluid. Confirmation is obtained on clinical examination and from a chest x-ray (see the chapter Heart Failure). Although NT-pro BNP levels are 2 to 10 times higher than the BNP levels in patients with heart failure, NT-proBNP is eliminated from the blood by the kidneys and is not reliable in patients with coexisting renal insufficiency, a condition that is often associated with heart failure. Clearance of BNP is not dependent on kidney function.

I. CLINICAL STUDIES

A. Maisel et al.

Methods: A study was done of 1586 patients who visited the emergency with acute shortness of breath, dyspnea, and whose BNP level was measured with a bedside assay. The diagnosis of heart failure was confirmed by two independent cardiologists.

Results: Dyspnea was caused by heart failure in 744 patients, 47%, with shortness of breath due to noncardiac causes; in 72 patients with a history of left ventricular dysfunction, 5%; and no finding of heart failure in 770 patients, 49%. The BNP levels were more accurate than historical or physical findings in establishing the diagnosis of heart failure. At a cut-off of 100 pg/ml, the diagnostic accuracy of BNP was 83%. A level of BNP less than 50 pg/ml indicates the absence of heart failure. Patients with the diagnosis of heart failure had mean BNP level results of 675 ± 50 pg/ml.

B. Mueller et al.

Methods: A prospective randomized controlled study of 452 patients who presented to the emergency department with acute dyspnea. The study randomly assigned 225 patients to BNP assay and 227 were assessed by a

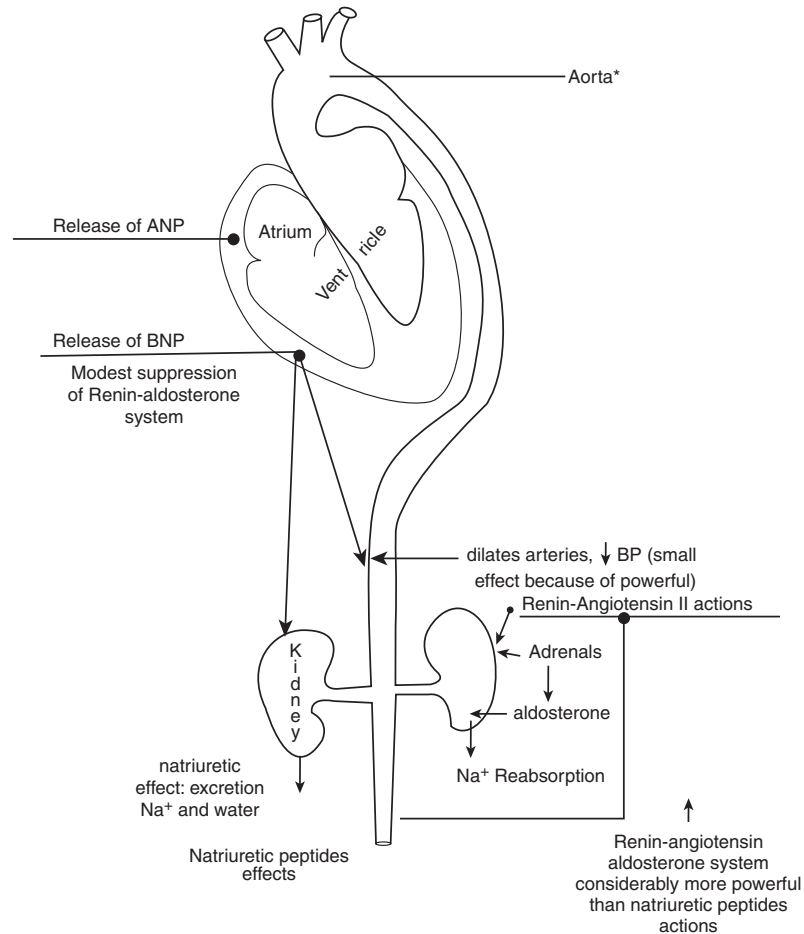

FIGURE 1 Effects of atrial, A-type, and ventricular, B-type natriuretic peptides. * = C-type natriuretic peptides released from vascular endothelium: a small effect. ANP = A-type natriuretic peptide. BNP = B-type natriuretic peptide. Note that the effects of the renin angiotensin aldosterone system is considerably more powerful than that of the natriuretic peptides so as to maintain adequate blood pressure during catastrophic events that profoundly decrease blood pressure (see Figure 1, in chapter entitled Angiotensin-Converting Enzyme Inhibitors/Angiotensin Receptor Blockers).

physician. Primary end points were the time to discharge the total cost of treatment.

Results: The use of BNP measurements reduced the need for hospitalization and intensive care: 75% of patients in the BNP group were hospitalized versus 85% assessed by a physician. The mean time to discharge was 8 days and 11 days in the BNP and control groups, respectively. The total cost of treatment was \$5410 and \$7264 in the BNP and control group, respectively.

C. Pierre-Yves et al.

Objectives: During stress and exercise BNP levels rise and lower cardiac workload. That benefits patients with coronary artery disease (CAD). This study sought to identify determinants of exercise rise in BNP levels in patients with CAD.

Methods: BNP and ANP levels were estimated at rest and peak exercise.

Results: Treatment with beta-blockers was a strong independent predictor of an increase in natriuretic peptide concentrations at exercise. Patients with CAD show a much higher exercise release of ANP and BNP when administered beta-blockers. These high levels of peptides appear to protect diseased hearts against stress.

II. PERSPECTIVE

Rapid measurement of BNP is useful in establishing or excluding the diagnosis of heart failure in patients with acute severe shortness of breath. BNP levels can confirm the diagnosis of heart failure when the cause of acute severe shortness of breath remains uncertain after assessment of the history, physical findings, and chest x-ray. The severity

of heart failure appears to be reflected by the height of BNP levels. The discovery that A-type (atrial), natriuretic peptide is secreted by the atrium (atrial natriuretic factor), was a major breakthrough that paved the way for the revelation of BNP's.

BIBLIOGRAPHY

- Adams, J., Apple, F. et al. New blood tests for detecting heart disease. *Circulation*, 109:e12–e14, 2004.
- Baughman, K. L. B-type natriuretic peptide — a window to the heart. *N. Engl. J. Med.*, 347:158–9, 2002.
- Lindahl, B., Lindbäck, J., Jernberg, T., Johnston, N., Stridsberg, M., Venge, P., Wallentin, L. et al. Serial analyses of N-terminal pro-B-type natriuretic peptide in patients with non-ST-segment elevation acute coronary syndromes. pages 533–541.
- Maisel, A. S., Krishnaswamy, P., Nowak, R. M. et al. Rapid measurement of the B-type natriuretic peptide in the emergency diagnosis of heart failure. *N. Engl. J. Med.*, 347:161–7, 2002.
- Mueller, C., Scholer, A., Laule-Kilian, K. et al. Use of B-type natriuretic peptide in the evaluation and management of acute dyspnea. *N. Engl. J. Med.*, 350:647–654, 2004.
- Pierre- Yves, M., Mertes, P. M., and Hassan-Sebbag, N. Exercise release of cardiac natriuretic peptides is markedly enhanced when patients with coronary artery disease are treated medically by beta-blockers. *J. Am. Coll. Cardiol.*, 43:353–359, 2004.
- Takeshi Soeki, Ichiro Kishimoto, Hiroyuki Okumura, Takeshi Tokudome, Takeshi et al. C-type natriuretic peptide, a novel anti-fibrotic and antihypertrophic agent, prevents cardiac remodeling after myocardial infarction.

Beriberi Heart Disease

I. Clinical Manifestations

GLOSSARY

cardiogenic shock extremely low blood pressures in the arteries caused by failure of the heart to eject blood; systolic blood pressure is usually less than 90 mmHg.

effusions accumulation of fluid.

pulmonary edema fluid in the air sacs and alveoli; the lungs become congested and severe shortness of breath occurs.

BERIBERI HEART DISEASE IS CAUSED BY SEVERE thiamine deficiency. This disease is most prevalent in the Far East, however, in the past decade its prevalence has markedly decreased. It occurs mainly in individuals whose staple diet consists of polished rice that is deficient in thiamine but high in carbohydrates.

Diets with a high carbohydrate content require a greater intake of thiamine. White bread enriched with thiamine has helped in this respect. Because alcohol is high in carbohydrate content but deficient in thiamine, some alcoholics become thiamine deficient and weakness of the heart muscle may occur. The disease is also common in fad dieters.

I. CLINICAL MANIFESTATIONS

Swelling of both legs is caused by edema and may become severe. Pitting edema of both legs may extend up to the

thighs and over the trunk. The heart becomes dilated and weakness of the muscle progresses to heart failure. Beriberi heart disease may cause sudden cardiac dysfunction within days of onset of symptoms. This condition is accompanied by low blood pressure, tachycardia, and lactic acidosis. Patients may die within hours or within days of cardiogenic shock and pulmonary edema.

On laboratory diagnosis for Beriberi heart disease serum pyruvate and lactic acid levels are increased. The ECG shows low-voltage QRS complex and prolongation of the QT interval. Chest x-ray usually shows dilatation of both ventricles and congestion of the lungs with pleural effusions.

Treatment including administration of 100 mg of IV thiamine, then 25 mg daily for about 2 weeks causes dramatic improvement. Although the initial treatment does not require digoxin and diuretics, a few days after starting thiamine therapy digoxin and diuretics are indicated and produce beneficial results. Disturbance of nerves in the legs often accompanies the heart symptoms and thiamine replacement improves this type of polyneuropathy.

BIBLIOGRAPHY

Givertz, M. M., Colucci, W. S., and Braunwald, E. Clinical aspects of heart failure, high output failure; pulmonary edema. In *Heart Disease*, sixth edition. E. Braunwald, D. P. Zipes, P. Libby, and R.O. Bonow, eds. W. B. Saunders, Philadelphia, 2005.

Beta-Blockers

- I. Beta-Receptors
- II. Mechanism of Action
- III. Salutary Effects
- IV. Indications
- V. Clinical Trials
- VI. Adverse Effects and Cautions
- VII. Classification
- VIII. Subtle Differences and Research Implications
- IX. Individual Beta-Blockers

- pulmonary edema** a condition in which heart failure causes marked congestion of blood in the lungs, and fluid escapes into the air sacs and alveoli preventing the oxygenation of blood, this is associated with severe shortness of breath at rest.
- systemole** period of contraction of the heart muscle especially of the ventricles; blood is ejected from the ventricles.
- ventricular fibrillation** the heart muscle does not contract but quivers; therefore there is no heartbeat (cardiac arrest) and no blood is pumped out of the heart; death occurs within minutes if the abnormal heart rhythm is not corrected.

GLOSSARY

- afterload** arterial impedance, restriction to blood flow delivered from the left ventricle; force against which the myocardium contracts in systole; a major determinant of wall stress.
- angina** short duration, recurrent chest pain or pressure often accompanied by feelings of suffocation and impending doom; most frequently associated with lack of blood and oxygen to the heart muscle.
- arrhythmia** general term for an irregularity or rapidity of the heartbeat, an abnormal heart rhythm.
- atherosclerosis** same as atheroma, raised plaques filled with cholesterol, calcium, and other substances on the inner wall of arteries that obstruct the lumen and the flow blood; the plaque of atheroma hardens the artery, hence the term atherosclerosis (sclerosis = hardening).
- dyslipidemia** the same as hyperlipidemia, elevated blood cholesterol, LDL cholesterol, triglycerides, or low HDL cholesterol.
- heart failure** a failure of the heart to pump sufficient blood from the chambers into the aorta; inadequate supply of blood reaches organs and tissues.
- ischemia** temporary lack of blood and oxygen to an area of cells, for example, the heart muscle, usually due to severe obstruction of the artery supplying blood to this area of cells.
- myocardial infarction** death of an area of heart muscle due to blockage of a coronary artery by blood clot and atheroma; medical term for heart attack or coronary thrombosis.
- preload** the degree of ventricular muscle stretch present at the onset of myocardial contraction; often expressed as end diastolic volume or pressure.

THE SURFACES OF CELLS IN VARIOUS ORGANS and tissues have receptor sites. Hormones and other chemicals act at their respective receptor sites to bring about a particular action in the cell. Adrenaline and noradrenaline are called catecholamines and are released from sympathetic nerve endings and as hormones from the adrenal glands. They have their major actions on receptor sites called beta-receptors. Stimulation of the sympathetic-adrenal system during danger or severe stress, for example, causes an outpouring of adrenaline and noradrenaline into the blood circulation and at nerve endings.

Catecholamines (adrenaline and noradrenaline) are stimulants and cause an increase in the force of contraction of the heart increasing heart rate, blood pressure, and blood sugar. An outpouring of catecholamines is necessary to prepare the body for a fight-or-flight response. Therefore, we need this surge of adrenaline if we have to flee from a charging bull. Although adrenaline and noradrenaline have positive effects, in excess they can cause overcharging of the cardiovascular system, which can precipitate ventricular fibrillation.

It is well documented that during a heart attack large quantities of noradrenaline are released into the heart muscle, which can precipitate abnormal heart rhythms, particularly, ventricular fibrillation. Adrenaline causes an increase in heart rate and an increase in blood pressure, thus causing the heart to work harder. Because a coronary artery is blocked during a heart attack, the increased work with less available oxygen causes further damage to the

heart muscle and increases the size of the muscle damage, causing a larger heart attack.

Beta-blocking drugs were originally discovered by Sir James Black of Imperial Chemical Industries. Since the introduction of the prototype, propranolol, for the management of hypertension in 1964, more than 12 beta-blocking drugs have become available. Beta-adrenergic blocking drugs have become the cornerstone of cardiac drug therapy.

I. BETA-RECEPTORS

By definition, beta-blockers block beta-receptors. Structurally they resemble the catecholamines (adrenaline and noradrenaline) and block the action of these catecholamines at their receptor sites. The beta-receptors are situated on the cell membrane and are believed to be a part of the adenylyl cyclase system. An agonist acting on its receptor site activates adenylyl cyclase to produce cyclic adenosine-5-monophosphate, which is believed to be the intracellular messenger of beta stimulation. There are two types of beta-receptors, beta-1 and beta-2.

A. Beta-1 Receptors

The beta-1 receptors are present mainly in the heart, renin-secreting tissues of the kidney, parts of the eye responsible for the production of aqueous humor, and to a limited degree in bronchial tissue of the lung. Beta-1-adrenergic receptors regulate heart rate and myocardial contractility, but in situations of stress with the provocation of epinephrine release stimulation of cardiac beta-2 receptors contribute to additional increases in heart rate and contractility.

B. Beta-2 Receptors

These are predominant in the bronchial tissues of the lung, vascular smooth muscle, insulin-secreting tissues of pancreas, gastrointestinal tract, and to a limited degree in the heart and coronary arteries. None of these tissues exclusively contains one subgroup of receptor. The population density of receptors decreases with age. In addition, the beta-receptor population is not static, and during long-term therapy with beta-adrenergic blocking agents the number of receptors is increased.

The heart contains beta-1 and beta-2-adrenergic receptors in the proportion 70:30. In heart failure, cardiac beta-1 receptors are reduced in number and population.

II. MECHANISM OF ACTION

Blockade of cardiac beta-1 receptors causes a decrease in heart rate, myocardial contractility, and velocity of cardiac contraction. Beta-blockers cause the heart muscle to work less, thus requiring less oxygen; in time of oxygen lack, such as during a heart attack or severe angina, this action can be life-saving. Because of the reduction in the oxygen requirement of the heart muscle, the beta-blocking drugs are effective in preventing the chest pain of angina pectoris. Because patients with angina have a high risk of developing a heart attack over ensuing years, beta-blockers are important for both pain and prevention.

An increase in adrenaline such as that produced during stress or vigorous exercise causes an increase in (1) the number and stickiness of blood platelets, (2) clotting factor VIII (the hemophilic factor), and (3) the viscosity of the blood. Beta-blockers block some harmful effects of adrenaline.

Beta-blockers have antiarrhythmic effects; they depress phase 4 diastolic depolarization and are effective in abolishing arrhythmias caused by increased catecholamines. This action is particularly important in patients with ischemic heart disease. The electrical impulse traffic through the AV node is reduced with beta-blockers and the rate of conduction is slowed. This important action slows the heart rate in patients with rapid heart rates caused by atrial fibrillation. There is also a favorable effect on ventricular arrhythmias, particularly those induced by increased sympathetic activity observed in patients with oxygen lack to the myocardium because of obstructive coronary artery disease. Blockade of beta-1 receptors reduces activity of the renin-angiotensin system in the kidney by reducing renin released from the juxtaglomerular cells; this action causes some lowering of blood pressure.

Pierre-Yves et al. have shown that patients with stable coronary artery disease exhibit much higher exercise releases of atrial and ventricular natriuretic peptides (ANP and BNP) when they are treated with beta-blockers these authors postulated that increased secretion of potent vasodilating and natriuretic agents constituted a mechanism for protecting diseased hearts against stress.

III. SALUTARY EFFECTS

Beta-blockers have been shown to prevent fatal and non-fatal heart attacks and sudden cardiac death. (The salutary effects of beta-adrenergic blockade are depicted in Fig. 1. A decrease in heart rate increases the diastolic interval during which the coronary arteries are filled with blood.

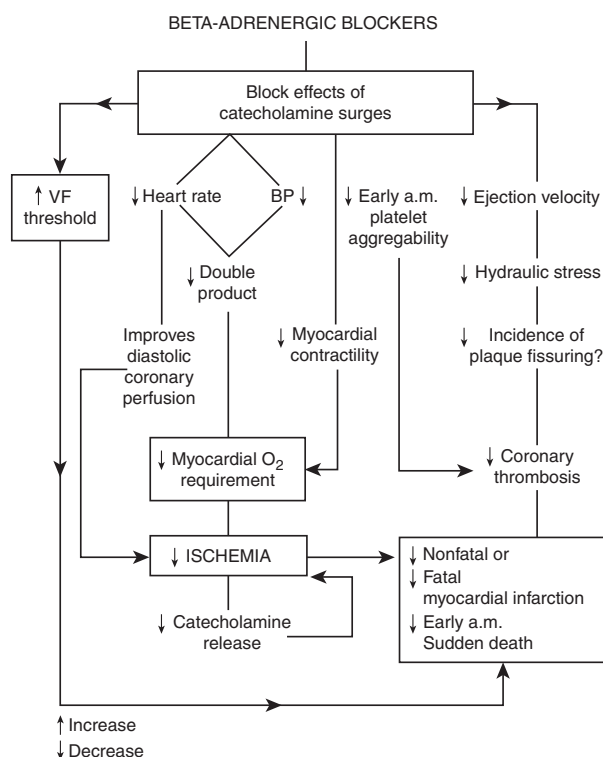

FIGURE 1 Salutary effects of beta-adrenergic blockade. (From Khan, M. Gabriel, (2003). *Cardiac Drug Therapy*, sixth edition, Philadelphia: W.B. Saunders, p. 3. With permission.)

The coronary arteries are squeezed during systole and blood flow is restricted. Thus beta-blockers increase oxygen supply to the myocardium. This major beneficial effect has not been given prominence by workers in the field.

Beta-blockers decrease the force and velocity of cardiac contraction and decrease the heart rate pressure product (RPP). This action decreases myocardial oxygen demand and is important in the relief of angina.

It is interesting to note the good effect of beta-blockers on the arterial system. The thousands of miles of arteries are constantly under pressure from the pulsatile force and velocity of blood as well as blood pressure. The decrease in cardiac ejection velocity and a decrease in hemodynamic stress on the arterial wall, especially at the branching of arteries, may decrease the atherosclerotic process and plaque rupture. Atherosclerosis is commonly seen where arteries divide. Beta-blockers reduce blood pressure as well as the force and velocity of blood flow at these dividing points of mechanical stress and provide some protection from vessel wall injury. This favorable effect is of paramount importance in patients with high blood pressure. Mechanical injury from the velocity and force of blood is the prime cause of vessel wall injury, which leads to atherosclerosis, dissection of the plaques of atheroma

and subsequent thrombosis, as well as rupture of an aneurysm (see the chapter Aneurysm).

A decrease in the fatal arrhythmias, an increase in ventricular fibrillation threshold, and amelioration of ventricular and supraventricular arrhythmias have been documented with beta-blockers. They decrease early morning platelet aggregation and arrhythmias induced by catecholamines. By doing this, they decrease the early morning peak incidence of heart attack and sudden death.

IV. INDICATIONS

A. Angina

Beta-blockers are first-line therapy for the management of stable angina. They have been shown to be more effective than oral nitrates and calcium antagonists. They reduce the recurrence of chest pain in more than 66% of patients. Many patients with angina manifest little pain, but they may have several episodes of ischemia during the day or night. These episodes can be adequately suppressed by the use of beta-blocking drugs (see the chapter Angina). In patients with unstable angina these drugs are used immediately with aspirin when the patient arrives in the emergency room.

B. Acute Myocardial Infarction

Beta-blockers are strongly recommended as therapy for acute myocardial infarction and are administered within minutes of arrival in the emergency room to virtually all patients who present with acute chest pain believed to be caused by a heart attack. As soon as an ECG confirms the diagnosis, an aspirin, a beta-blocker, and a thrombolytic agent are administered. In patients with acute myocardial infarction beta-blockers have been shown to prevent cardiac death and reduce infarct size. In these patients, beta-blockers are often continued for several years (see Fig. 2).

C. Hypertension

Beta-blockers and diuretics remain first-line agents for the management of virtually all patients with hypertension. Beta-blockers are the drugs of choice in younger and older white patients. Contrary to the opinion of some experts, beta-blockers have been proven effective in older white patients. Beta-blockers are particularly indicated in all individuals with hypertension and concomitant coronary

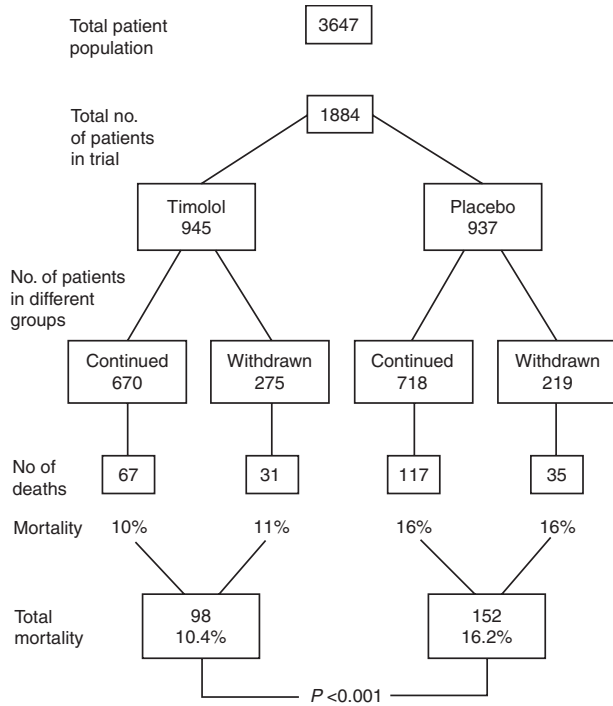

FIGURE 2 Results of the Norwegian Multicenter Postinfarction Trial of timolol. Timolol was administered at a dosage of 10 mg twice daily from 7–28 days. Patients were followed for a mean duration of 17 months. The age range was 20–75 years. (Reprinted from *Am. J. Cardiol.* 66:4C, 1990, with permission from Excerpta Medica, Inc.)

artery disease, diabetes, or dyslipidemia. They are indicated for hypertension in younger African-Americans; they appear to be less effective in older patients of African origin. (see the chapter Hypertension). Beta blockers are also indicated in hypertensive patients with mild-to-moderate heart failure.

D. Arrhythmias

Atrial fibrillation is the most common sustained arrhythmia observed in clinical practice and is a common disorder observed worldwide. Beta-blockers remain the mainstay of therapy to control the rapid heart rate in these patients. These agents have replaced digoxin, except in patients with severe heart failure. In a few patients paroxysmal attacks may be prevented (see the chapter Atrial Fibrillation).

Ventricular premature beats, particularly those caused by coronary artery disease and mitral valve prolapse, are another type of arrhythmia. Nonsustained ventricular tachycardia may respond to beta-blockers in patients with coronary artery disease and repetitive ventricular fibrillation caused by electrocution.

E. Heart Failure

The harmful effects of overactivation of the sympathetic nervous system in heart failure are ameliorated significantly by beta-blockers. The judicious use of titrated doses of beta-adrenergic blockers has been shown to improve quality of life, recurrence of heart failure, and mortality in patients with various grades of heart failure. The COPERNICUS study involved 2289 patients with severe heart failure and ejection fractions of less than 20%. The treatment drug carvedilol caused significant reductions in mortality and hospitalization for heart failure. The COMET study randomized 1511 patients with chronic heart failure (ejection fraction less than 35%) to treatment with carvedilol and 1518 to metoprolol. Follow up at 58 months showed all-cause mortality to be 34% for carvedilol and 40% for metoprolol, $p = 0.0017$.

F. Elective Percutaneous Coronary Intervention

Elective percutaneous coronary intervention (PCI) involving balloon angioplasty and intracoronary stent implantation is now done in many centers worldwide for the management of coronary artery disease. All patients undergoing PCI are administered beta-blocking drugs that are continued indefinitely. A clinical trial has shown that beta-blocker therapy is associated with a marked long-term survival benefit among patients undergoing successful PCI. Beta-blocker therapy has been shown to be associated with a reduction from 6 to 3.9% at one year ($P = 0.0014$).

G. Dissecting Aneurysm

A dissecting aneurysm of the aorta is a life-threatening condition resulting in death in greater than 75% of patients. A beta-adrenergic blocking agent is the drug of choice to reduce aortic pressure which decreases the rate of dissection. A beta-blocker is often combined with nitroprusside to lower blood pressure, but even when the systolic blood pressure is as low as 110 mmHg, a beta-blocker is still indicated to reduce cardiac ejection velocity and thus the aortic pressure.

H. Mitral Regurgitation and Mitral Stenosis

Recent clinical trials with carvedilol in patients with mitral regurgitation have documented improvement in geometry of the left ventricle. In mitral regurgitation (a leaky valve), blood flows backward through the widely opened valve

that should be shut and flows from the left ventricle into the left atrium. The left ventricle becomes enlarged and finally weakens causing heart failure. In an animal study of mitral regurgitation, the ACE inhibitor, lisinopril, reduced pre- and afterload, but its effect on the left ventricular contractility was insignificant. Atenolol, when added to lisinopril, achieved a maximum hemodynamic benefit and also restored left ventricular contractility. Moderate-to-severe mitral regurgitation is an extremely difficult condition to manage; the timing for surgery in patients with severe disease is often a dilemma. Any cardioactive agent that causes amelioration of the disease process is a welcome addition to the drug armamentarium.

Beta-blockers are the cornerstone of treatment for pregnant patients with moderate-to-severe mitral stenosis. These agents slow the heart rate which allows filling of the left ventricle and prevents life-threatening pulmonary edema. In mitral stenosis the mitral valve opening is stenosed or tight, and blood flow from the left atrium is restricted. This flow is further decreased when the heart rate is fast. Patients with mitral valve prolapse and bothersome palpitations respond favorably to beta-blockers.

I. Hypertrophic Cardiomyopathy

Although medical treatment with beta-blockers does not cause a decrease in mortality, symptoms are often significantly relieved with a beta-blocking agent. See chapter entitled "Cardiomyopathy."

J. Perioperative Mortality

Beta-blockers have been shown to decrease morbidity and mortality in patients undergoing coronary artery bypass surgery and in cardiac patients undergoing other types of surgery. Beta-adrenergic blockade allows safer induction of anesthesia and prevents the hypertensive response to endotracheal intubation. These agents reduce the occurrence of arrhythmias in the intra- and postoperative periods. Both atenolol and bisoprolol have been shown in randomized clinical trials to reduce morbidity and mortality when given perioperatively and for one week postoperatively.

K. Marfan Syndrome

This disease often causes dilatation of the ascending aorta, which results in aortic dissection. Prophylactic beta-adrenergic blockade slows the rate of aortic dilation and retards the development of aortic complications.

L. Diabetic Patients

Death in the majority of patients with type 2 diabetes is caused by cardiovascular disease. Both fatal and nonfatal and sudden heart attacks are common in diabetics. Unfortunately, the usual optimal treatment of diabetes with insulin or oral agents does not significantly prevent cardiovascular complications. Beta-adrenergic blockers are usually considered by experts to be relatively contraindicated in diabetics, particularly those with dyslipidemias. This expert advice is illogical. These are the only cardioactive agents along with aspirin that could protect the heart from serious events and dyslipidemia can be controlled with statins. (See the chapter Diabetes). Also, beta-blockers appear to have a renoprotective effect. In the SOLVD heart failure study, surprisingly in contrast to the ACE inhibitor enalapril, beta-blockers were renoprotective in both the ACE inhibitor and the placebo groups. See the later discussion of the UKPDS beneficial results in diabetics treated with a beta-blocker in Section V.D.

M. Other Indications

Prolonged QT interval syndromes may cause syncope or sudden death and beta-blockers provide some benefit in these patients. An electrical storm in the heart may precipitate multiple episodes of ventricular tachycardia or ventricular fibrillation and repetitive ventricular fibrillation resistant to therapy. The beneficial effect of the beta-blocker propranolol on recurrent ventricular fibrillation caused by electrocution was documented in 1970s, but little attention was given to this report. Recent studies have documented the role of beta-blockers in electrical storms and today propranolol is used for the management of repetitive ventricular fibrillation resistant to defibrillation.

V. CLINICAL TRIALS

Clinical trials have documented that beta-blockers significantly prevent death in patients who are given the drug from the first week of the heart attack and for an additional two years.

A. Norwegian Postinfarction Timolol Trial

This hallmark clinical trial was the first to document the life-saving effects of beta-blockers in patients following a heart attack (see Fig. 2). In this superbly well-conducted Norwegian study, 1884 patients were randomized to two

groups. The first group of 942 patients was started on a beta-blocker, timolol, 7 days after a heart attack. The other group received a placebo. At the end of two years, the treated group had a 35% reduction in heart death, 28% reduction in new heart attack, and 67% reduction in sudden death ($p < 0.001$). The impressive results were observed in smokers and nonsmokers; they were published in 1981 (see Fig. 2).

B. The American Beta-Blocker Heart Attack Trial

The Beta-Blocker Heart Attack Trial (BHAT) gave similar if not just as impressive results. In 16,400 randomized patients, propranolol, 120–240 mg, administered to patients 14 days after myocardial infarction and followed for 2 years showed a significant 26% reduction in mortality rate. Propranolol was not effective in smokers, however, because of the interactions in the liver; cigarette smoking lowers the blood levels of propranolol and decreases cardioprotective effects.

C. The CAPRICORN Study

In this recent, large multicenter study, patients from 1 to 21 days after acute myocardial infarction and ejection fraction less than 40% were randomized. The control group received optimal medical therapy including the use of ACE inhibitors. The treated group received carvedilol 6.25 mg increased progressively to 25 mg twice daily. Carvedilol caused a significant 23% reduction in all-cause mortality in patients observed for 2.5 years; the mortality was 116, (12%) in the treated versus 151 (15%) in the placebo group. The absolute reduction in risk was 2.3%. Forty-three patients need to be treated for one year to save one life. This reduction is virtually the same as that observed in a meta-analysis of three ACE inhibitor trials. Most important, the reduction observed with carvedilol is in addition to those of ACE inhibitors alone.

D. The UKPDS Results

The UKPDS results confirm that in type 2 diabetes, beta-blockers significantly reduced all-cause mortality, risk for heart attack, stroke, and importantly peripheral vascular disease as well as microvascular disease. Over a follow up of nine years the change in albuminuria and serum creatinine was the same in both the ACE inhibitor (captopril), and the beta-blocker groups.

E. Implications

Beta-blockers and aspirin are proven by studies to prevent death from heart attack. About 450,000 heart attack patients survive to leave hospitals in the United States and Canada annually, and about 100,000 of these patients will have another heart attack in the following year. Beta-blockers can prevent a heart attack in approximately 20% (30,000) of these patients and prevent death in about 25%. Yet these cardioprotective drugs that can prolong life are not advocated and prescribed by many internists and family physicians because of the rare incidence of impotence and fatigue. Many practitioners continue to use newer agents, particularly, calcium antagonists, nitrates, and other agents that have not been shown to prolong life in randomized clinical trials.

VI. ADVERSE EFFECTS AND CAUTIONS

Beta-blockers are safe cardioactive agents if the warnings and contraindications are followed. They are not advisable in patients with severe class IV heart failure. They are indicated, however, in class I–III heart failure. Class IV patients who have been stabilized and are no longer decompensated can be started on very small doses of carvedilol (3.5 mg).

Beta-blockers are contraindicated in patients with bronchial asthma and in patients with severe chronic obstructive pulmonary disease including emphysema. Patients with mild chronic bronchitis may be given a cardioselective beta-1 agent and may require supplemental salbutamol. Other contraindications include:

1. Complete heart block and varying grades of heart block
2. Severe bradycardia less than 48 beats per minute
3. Allergic rhinitis
4. Insulin-dependent diabetics who are prone to hypoglycemia
5. Raynaud's phenomenon

Adverse side effects of beta-blockers include tiredness and fatigue in about 10% of patients, erectile dysfunction in about 10%, precipitation of heart failure in patients with poor left ventricular function, slowing of the heart rate causing bradycardia less than 50 beats per minute, depression in less than 5%, very cold extremities in less than 10%, and vivid dreams. Switching to a hydrophilic drug excreted by the kidney may decrease vivid dreams.

VII. CLASSIFICATION

A classification of beta-blockers is given in Fig. 3. Cardioselectivity indicates that the drug chiefly blocks beta-1

receptors in the heart and partially spares beta-2 receptors in the lungs and blood vessels. Large doses of all beta-blocking agents block beta-2 receptors, thus, cardioselective drugs are not cardioselective. Bisoprolol is more cardioselective than metoprolol or atenolol. The classification into cardioselective and nonselective is important, but oversimplified.

VIII. SUBTLE DIFFERENCES AND RESEARCH IMPLICATIONS

The subtle differences that exist among the available beta-blocking drugs are often overlooked. Figure 3 gives a working classification. Cardioselective agents are safer than nonselective beta-blockers in diabetic patients and in those with mild-to-moderate chronic obstructive pulmonary disease. This information appears to be well known worldwide. Agents with beta-agonist activity (intrinsic sympathomimetic activity, ISA) are not cardioprotective, e.g., pindolol, and should become obsolete. Of the cardioselective agents only metoprolol has been shown in randomized clinical trials to significantly reduce coronary heart disease mortality and events. Bisoprolol has not been tried in trials of infarction patients but was beneficial in heart failure trials. Atenolol, a popular cardioselective agent, is used worldwide but has never been tested in a randomized trial of post myocardial infarction patients or

in patients with left ventricular dysfunction or heart failure. It should not be assumed that this agent has similar cardioprotective properties as metoprolol, carvedilol, propranolol, bisoprolol, and timolol (see earlier discussion of clinical trials in Section IV).

Of the cardioselective agents only bisoprolol and metoprolol have been shown to decrease cardiac mortality. Both of these drugs have lipophilic properties. Lipophilicity allows a high concentration of drug in the brain. This appears to block sympathetic discharge in the hypothalamus and elevate central vagal tone to a greater extent than water-soluble, hydrophilic agents. This may relate to the prevention of sudden cardiac death. Abal et al., in a rabbit model, showed that “although both metoprolol (lipophilic) and atenolol (hydrophilic) caused equal beta blockade, only metoprolol caused a reduction in sudden cardiac death.” It appears that this information has not reached clinicians or researchers.

In addition, only carvedilol, metoprolol, timolol, and propranolol — all lipophilic agents — have been shown to reduce mortality and morbidity in postinfarction patients. Atenolol is nonlipophilic and probably provides less cardioprotection than proven agents. It has not been adequately tested in randomized trials. Sotalol and oxprenolol, both nonlipophilic, have been tested in randomized clinical trials and have not been shown to significantly reduce mortality or morbidity. Oxprenolol has some beta-agonist activity that negates cardioprotection.

Both nonselectivity and lipophilicity may provide cardioprotection. It is possible that cardioselective agents are not as cardioprotective as beta-1 and beta-2 blocking agents. Large, randomized clinical trials in the post myocardial infarction patients with long-term follow up have only been carried out with the nonselective agents timolol, propranolol, and recently with carvedilol. Each agent proved beneficial in reducing cardiac mortality and morbidity. The cardioselective metoprolol reduced mortality and morbidity in a postinfarction trial but follow up was three months. Metoprolol was also successful in a heart failure trial (MERIT). The cardioselective bisoprolol reduced mortality and morbidity in a heart failure trial (CIBIS II), but this agent is partially lipophilic. Atenolol was used in an early acute myocardial infarction trial and the result was only modestly significant. The methodology was unsound in this trial; patients were admitted 4, 6, and 12 hours post infarction, so this was not a genuine trial of a beta-blocker during the first few hours of infarction. Unfortunately atenolol is the beta-blocking drug most often used in antihypertensive trials comparing beta-blockers with diuretics, calcium antagonists, and ACE inhibitors. A nonselective, lipophilic drug such as carvedilol that is proven effective in postinfarction patients

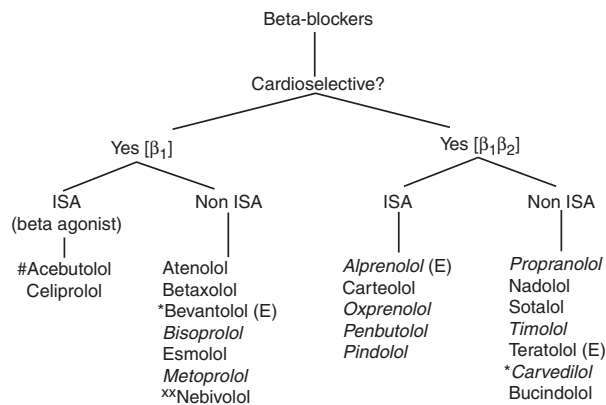

All available in the United States except if labeled (E)

ISA = Intrinsic sympathomimetic activity

E = Europe

* added weak alpha-blocker

Italic = lipid soluble

weak β_1 selectivity, weak ISA

xx = vasodilatory beta-blocker

FIGURE 3 Classification of beta-blockers. All available in the United States except if labeled (E). ISA = intrinsic sympathomimetic activity; E = Europe; * = added weak alpha-blocker; *italic* = lipid soluble; # = weak β_1 selectivity, weak ISA; xx = vasodilatory beta blocker.

and in patients with severe heart failure should be tested in hypertensive patients. The cardioselective agent bisoprolol has lipophilic properties and also deserves testing in hypertensive trials.

Beta blockade causes a mild increase in serum potassium because of blockade of the beta-2-mediated epinephrine activation of the Na K⁺ ATPase pump which transports potassium from extracellular fluid into the cells. During stress, serum potassium has been observed to decrease 1.0 mEq/L; this can be prevented by blockade of beta-2 receptors. Nonselective beta-blockers are superior to selective agents in preventing fluctuations of serum potassium concentration during stress and possibly during acute myocardial infarction. It may also be more cardioprotective than cardioselective agents.

Carvedilol has important differences from atenolol, metoprolol, and other beta-blockers. This lipophilic, beta-1, beta-2 blocking agent is a very mild alpha-1 blocker and causes arteriolar dilatation. Antioxidant and antiproliferative properties have also been noted. Carvedilol also lowers plasma endothelin levels.

IX. INDIVIDUAL BETA-BLOCKERS

A. Acebutolol

This relatively cardioselective, partially hydrophilic and lipophilic agent possesses mild beta-agonist activity. A dosage of 200–300 mg twice daily is given for hypertension. Because of the presence of beta-agonist activity, this drug is not indicated for the management of angina or myocardial infarction.

B. Atenolol

This beta-1 cardioselective agent is water-soluble, hydrophilic, and eliminated by the kidneys. It has a low side effect profile and is therefore widely used. As outlined above, the drug has not been shown to decrease mortality in randomized trials. A dosage of 25–50 mg once daily is given, but a dose of 75 mg is required in some patients with angina or hypertension.

C. Bisoprolol

This agent is highly beta-1 selective and is more cardioselective than metoprolol and atenolol. It is 50% lipophilic and metabolized in the liver. The water-soluble, hydrophilic component is excreted by the kidneys. The concentration of unchanged bisoprolol in rat brain is lower than that of metoprolol or propranolol, but higher than

that of atenolol after dosing. This agent has a low side effect profile. A dosage of 5–10 mg once daily, and a maximum of 15 mg daily is recommended.

D. Carvedilol

This noncardioselective agent is a beta-1, beta-2 receptor blocker with very mild alpha-1 vasodilating activity. A recent randomized trial has shown the drug to be effective in reducing mortality in patients with acute myocardial infarction with an ejection fraction of less than 40%. In a large, randomized trial the drug significantly decreased mortality and morbidity in patients with moderate and severe heart failure. Patients are given a dosage of 3.125 mg daily for heart failure, titrated slowly over weeks to 12.5–25 mg twice daily. For hypertension the dosage is 12.5 mg then 25 mg, if necessary, with a maximum of 50 mg daily.

E. Metoprolol

This beta-1 cardioselective agent has been used extensively. It is commonly used in the management of angina, hypertension, and heart failure; clinical trials have shown the drug to be effective in reducing morbidity and mortality in patients with a moderate degree of heart failure. Metoprolol is commonly prescribed to reduce the rapid heart rate in patients with atrial fibrillation, but other beta-blockers have similar effects.

F. Nebivolol

Nebivolol is a new, highly selective beta-1 receptor antagonist with antioxidant properties that has been shown to cause vasodilatation in humans. This agent reverses endothelial dysfunction in hypertensive patients. It appears that the drug causes vasodilatation through an endothelial beta-2-adrenergic receptor mediated nitric oxide production. Nitric oxide formed in arteries causes salutary vasodilatation. The vascular release of superoxide is increased in atherosclerotic arteries and oxygen can inactivate nitric oxide; oxidative inactivation of nitric oxide is a cause of endothelial dysfunction. Cominacini et al. has shown that nebivolol increases nitric oxide by also decreasing its oxidative inactivation.

G. Others

Other agents include the well known propranolol, but its efficacy is questionable and should become obsolete for the

management of hypertension, angina, and following myocardial infarction, because the other agents described above cause less adverse effects. Sotalol is indicated mainly for the management of some patients with paroxysmal atrial fibrillation to maintain sinus rhythm (see the chapter Atrial Fibrillation).

BIBLIOGRAPHY

- Abald, B., Bjorkman, J. A., Edstrom, T. et al. The role of central nervous system beta-adrenoreceptors in the prevention of ventricular fibrillation through augmentation of cardiac vagal tone (abstract). *J. Am. Coll. Cardiol.*, 17:165A, 1991.
- Bakris, G. L., Fonseca, V., Katholi, R. E. et al. Metabolic effects of carvedilol versus metoprolol in patients with type 2 diabetes mellitus and hypertension. A randomized controlled trial for the GEMINI Investigators. *JAMA*, 292:2227–2236, 2004.
- Billinger, M., Seiler, C., Fleisch, M. et al. Do beta-adrenergic blocking agents increase coronary flow reserve? *J. Am. Coll. Cardiol.*, 38:1866–1871, 2001.
- Carlberg, B., Samuelsson, O., Lindholm, L. H. et al. Atenolol in hypertension: Is it a wise choice? *Lancet*, 364:1684–89, 2004.
- CAPRICORN investigators: Effect of carvedilol on outcome after myocardial infarction in patients and with left ventricular dysfunction. *Lancet*, 357:138, 2001.
- CIBIS-II: The cardiac insufficiency bisoprolol study II. A randomized trial. *Lancet*, 353:9–13, 1999.
- COMET: Comparison of carvedilol and metoprolol on clinical outcomes in patients with chronic heart failure in the carvedilol or metoprolol European trial (COMET). A randomized controlled trial. *Lancet*, 362:7–13, 2003.
- Cominacini, L., Pasini, A. F., Garbin, U. et al. Nebivolol and its 4-keto derivative increase nitric oxide in endothelial cells by reducing its oxidative inactivation. *J. Am. Coll. Cardiol.*, 42:1838–1844, 2003.
- Cruickshank, J. M. Beta-blockers continue to surprise us. *Eur. Heart J.*, 21:355, 2000.
- Khan, M. Gabriel. Beta-blockers, the cornerstone of cardiac drug therapy. In *Cardiac Drug Therapy*, sixth edition, W. B. Saunders/Elsevier, Philadelphia, 2003.
- Marie, P.-Y., Mertes, P. M., Hassan-Sebbag, N. et al. Exercise release of cardiac natriuretic peptides is markedly enhanced when patients with coronary artery disease are treated medically by beta blockers. *J. Am. Coll. Cardiol.*, 43:353–359, 2004.
- McMurray, J., Køber, L., Robertson, M. et al. Antiarrhythmic effect of carvedilol after acute myocardial infarction. *J. Am. Coll. Cardiol.*, 45:525–530, 2005.
- MERIT-HF Study Group. Effect of metoprolol CR/XL in chronic heart failure. Metoprolol CR/XL randomized trial in congestive heart failure (MERIT-HF). *Lancet*, 353:2001–2007, 1999.
- Nemoto, S., Hamawaki, M., DeFreitas, G. et al. Differential effects of the angiotensin-converting enzyme inhibitor lisinopril versus the beta adrenergic receptor blocker atenolol on hemodynamics and left ventricular contractile function in experimental mitral regurgitation. *J. Am. Coll. Cardiol.*, 40:149–54, 2002.
- Packer, M., Coats, J. S., Fowler, M. B. et al. COPERNICUS: For the carvedilol prospective in randomized cumulative survival study group. Effect of carvedilol on survival in severe chronic heart failure. *N. Engl. J. Med.*, 344:1651, 2001.
- Pratt, C. M. et al. Three decades of clinical trials with beta-blockers. *JACC*, 45:531–532.
- SOLVD Investigators. Effect of enalapril on survival in patients with reduced ventricular ejection fractions and congestive heart failure. *N. Engl. J. Med.*, 325:293, 1991.

Blood Clots

- I. Causes of Blood Clots
- II. Nondrug Treatment
- III. Drug Treatment

- 3. Clot-dissolving drugs (thrombolytic agents)
- 4. Agents that prevent clot formation (anticoagulants and antiplatelet drugs).

GLOSSARY

acute coronary syndrome this syndrome defines patients with acute chest pain caused by myocardial infarction or unstable angina.

anticoagulants blood thinners.

atheroma same as atherosclerosis, raised plaques filled with cholesterol, calcium, and other substances on the inner wall of arteries that obstruct the lumen and the flow of blood; the plaque of atheroma hardens the artery, hence the term atherosclerosis (sclerosis = hardening).

myocardial infarction death of an area of heart muscle due to blockage of a coronary artery by blood clot and atheroma, medical term for heart attack.

PCI percutaneous coronary intervention; percutaneous transluminal coronary angioplasty (PTCA), often involving the use of intracoronary stents.

platelets very small disk-like particles that circulate in the blood alongside red and white blood cells initiating the formation of blood clots; platelets clump and form little plugs called aggregation, thus causing bleeding to stop.

IN 90% OF CASES, THE CAUSE OF A FATAL OR A nonfatal heart attack is a blood clot in a coronary artery (coronary thrombosis). The clot often occurs on the surface of a plaque of atheroma that is partially obstructing the lumen of the coronary artery. Patients may have many large atheromatous plaques and yet not develop a clot over a 5- to 15-year period. There is no test that can tell us when and where a clot will occur. Cholesterol, hypertension, exercise, and cigarette smoking have little to do with the clotting of blood; therefore, we must look elsewhere.

Reduction in fatal and nonfatal heart attacks requires the prevention and therapeutic strategies outlined below.

- 1. Prevention of atheroma formation in arteries
- 2. Prevention of erosion or rupture of atheromatous plaques in the coronary arteries and cerebral circulation

I. CAUSES OF BLOOD CLOTS

Blood clots are believed to occur in the coronary arteries because of platelets that become sticky when they come in contact with the damaged lining of blood vessels, where atheroma formation has commenced. Platelets interact with the damaged surfaces, and chemicals that are produced at the site cause the platelets to clump (platelet aggregation) and form a clot. Chemicals in the body that cause platelets to clump or sludge include collagen from the damaged vessel wall, adrenaline, and a very powerful platelet-clumping chemical called thromboxane A₂.

Platelets are small particles present in the blood and circulate as elliptical flat disks. They are the body's first defense against excessive bleeding. At the site of bleeding, platelets accumulate and stick together to form a clump to plug the seepage of blood. When the platelets clump together, other clotting factors contribute to the final conversion of a blood protein, fibrinogen, which turns into a mesh of fibrin strands that traps red cells and additional platelets, thus forming a firm clot.

Platelets are most sticky when they are newly released from the bone marrow. This may occur 4–10 days after any type of surgery; for example, there is a higher incidence of clots in veins of the legs after surgical operations. The lack of movement of the legs causes a slowing of the circulation in veins and increases the chances of a clot in the deep veins of the legs.

Mild cooling and chilling of the body without hypothermia can lead to an increase in the total number and stickiness of platelets and may increase clotting. This may influence the incidence of coronary thrombosis in winter. During stress, or in early morning, adrenaline and other chemicals increase the number and stickiness of platelets, which may clump onto an atheromatous plaque and cause a coronary thrombosis and myocardial infarction

(MI). It is not surprising, therefore, that most fatal heart attacks occur in the early morning hours between 5 and 8 a.m. Certain foods, especially high-fat foods, increase the stickiness of platelets and influence other blood-clotting factors, but to a small extent.

Atheromatous plaques produce turbulence and slow the blood flow in the coronary artery. The force of blood and increases in blood pressure can cause fissures or rupture of plaques. Platelets stick to these areas on the plaque and can start clot formation. Prevention of clots will be achieved if the formation of atheromatous plaques and their rupture are prevented. Plaque rupture liberates highly thrombogenic substances that rapidly cause clotting and blockage of arteries.

Nicotine and carbon monoxide, which are by-products of cigarette smoking, increase platelet stickiness and may be important factors. Carbon monoxide from cigarette smoke and exhaust of motor vehicles increase atheroma formation. Some foods have a high vitamin K content and increase the concentration of a clotting factor made in the liver (prothrombin). In addition, fibrinogen, the final protein involved in the formation of clots, is manufactured in the liver; it has been shown that the mean fibrinogen concentration and viscosity in the blood is increased in patients who have had heart attacks. Thus, it is important to recognize that certain foods other than those involved in elevating blood cholesterol may be important in increasing or decreasing clot formation. Some foods have properties that may prevent clot formation, albeit with a modest effect. (see Section VII in the chapter Cholesterol).

II. NONDRUG TREATMENT

As a nondrug treatment, these dietary measures are strongly advised. Eat less fatty meals, which reduces saturated fat and hydrogenated fat intake. Saturated fats form LDL (bad) cholesterol in the body. Try to increase the intake of foods that may prevent blood clotting, particularly onions, garlic, and foods containing alpha-linolenic and eicosapentaenoic acids; the latter are derived from fish and cod liver oil. The polyunsaturated acids in the diet of the fish-eating Japanese and Inuit prevent clumping of platelets and have favorable effects on the blood-clotting system. These foods decrease platelet clumping as well as increase vessel wall prostacyclin (prostaglandin), a compound that helps to keep the lining of the artery clean. Try to increase your consumption of fish, for example, mackerel and salmon, which have a high content of the polyunsaturated fatty acids. Linolenic acid has been

proven valuable in the prevention of plaque (see Section VII in the chapter Cholesterol).

Avoid or sparingly use alfalfa, turnip greens, and broccoli, which are very high in vitamin K, and lettuce, cabbage, and spinach, which have a moderate content of vitamin K. The concentration of prothrombin, a blood-clotting factor, can be increased by foods containing high amounts of vitamin K. If the anticoagulants warfarin or Coumadin are prescribed, use these foods in moderation, for example, the same quantities four days weekly rather than two days of heavy consumption. It is more difficult to thin the blood and more frequent blood tests may be necessary if these foods are not used in moderation.

III. DRUG TREATMENT

A. Thrombolytic Agents

Rentrop reported successful recanalization of coronary thrombotic occlusion with intracoronary infusion of streptokinase in patients. Streptokinase was the first thrombolytic agent employed, and its usefulness was first documented in the Italian trial of intravenous streptokinase (GISSI). This drug remains in use today because it is the least expensive of the available thrombolytic agents and has a low risk for intracranial hemorrhage compared with other agents that are modestly better in dissolving clots. The internationally run British trial, the International Study of Infarct Survival (ISIS-2), showed that an intravenous infusion of 1.5 million units of streptokinase administered over 1 h is not particularly expensive or troublesome to give routinely, and it provides significant reduction in mortality and morbidity in patients seen within 3 h of onset of chest pain. Most important, intravenous or subcutaneous heparin is not necessary when streptokinase is used; this reduces the risk for intracranial hemorrhage.

The American run international trial, Global Utilization of Streptokinase and t-PA for Occluded Coronary Arteries (GUSTO), demonstrated a modest 14% mortality reduction over streptokinase. Despite an increased risk of intracranial hemorrhage and the cumbersome use of intravenous heparin for several days, t-PA was established as the thrombolytic drug of choice for the management of acute MI and gained widespread acceptance in the United States. Streptokinase continued to be the main agent used in the UK, Europe, and developing countries with t-PA used for selected cases and for patients allergic to streptokinase.

The ASSENT-2 study compared single bolus tenecteplase with front-loaded t-PA. At 30 days mortality rates were almost identical, but in patients treated after 4 h the mortality rate was 7% with tenecteplase and 9.2% with t-PA. Additionally, tenecteplase is given as a bolus versus intravenous infusions for t-PA, thus, tenecteplase has replaced t-PA as the agent of choice. Intracranial hemorrhage in patients over age 75 remains a problem with the use of these powerful thrombolytic agents. The risk is lower with streptokinase. It has been established that it is not the selection of thrombolytic agent that matters, but the time the agent is used. It is more important to give any thrombolytic agent up to 3 h of symptom onset. There are some life-saving properties from 4 to 6 h, and between 6 and 12 hours there is a modest reduction in mortality rate that must be weighed against the risk of intracranial hemorrhage, particularly in patients over age 75.

In hospitals worldwide when a patient is admitted with a heart attack within 3 h of onset of chest pain, the doctor will inject a thrombolytic drug. Depending on availability and costs, tenecteplase, streptokinase, t-PA, or reteplase are used because they have all been shown in large randomized controlled trials to be effective in dissolving freshly formed clots. When a clot prevents blood from reaching part of the heart muscle, this area of the heart muscle dies within an hour. Patients must get to a hospital as quickly as possible within a half hour of chest pain. After 6 h, dissolving the clot may not help. To prevent MI, it is necessary to prevent the clot from forming in the first place.

In patients presenting within 4 h of symptom onset, speed of reperfusion is important. In more than 6% of patients admitted to U. S. hospitals, the door-to-needle time is in excess of 30 minutes, which is still inexcusably high. The door-to-needle time should be kept to less than 15 minutes.

B. Antiplatelet Agents

Antiplatelet agents include aspirin; clopidogrel, which has replaced ticlopidine; dipyridamole; and the newer agents, platelet glycoprotein receptor blockers. These drugs prevent platelet clumping (aggregation). They are not anticoagulants and do not cause spontaneous bleeding.

I. Aspirin

Supplied: Aspirin blocks an enzyme (cyclooxygenase) within the blood platelets and prevents the formation of thromboxane A₂, which causes clumping of platelets.

A dose of aspirin as low as 80 mg daily, a quarter of an ordinary aspirin, is capable of blocking the formation of thromboxane A₂. A dose of 325 mg (one ordinary aspirin) stops platelet clumping for 2–5 days. Clinical trials have confirmed that a small dose of aspirin, 160–325 mg daily soon after a heart attack, can prevent heart attacks and death.

Dosage: For coronary artery disease or those at risk, a 325-mg coated or 80- to 81-mg aspirin daily is recommended. This therapy provides modest protection from coronary thrombosis. More important is that patients take two or three chewable aspirin (80 to 81 mg) immediately at the onset of chest pain, because this may prevent a heart attack or death in up to 20% of patients. This strategy is more important than the use of nitroglycerin under the tongue, which does not prevent a fatal or nonfatal heart attack (see the chapter Aspirin for Heart Disease).

2. Dipyridamole

Supplied: Tablets 50 mg, 75 mg.

Dosage: 50 to 75 mg three times daily one hour before meals.

This drug is not beneficial when used alone, but in combination with aspirin it has been shown to reduce the incidence of clotting of coronary artery bypass grafts (CABG). In animal experiments, dipyridamole has been shown to be effective in preventing platelet clumping. Rats stressed with electric shocks developed platelet clumping in the coronary arteries, which produced small areas of damage to the heart muscle (MIs). This damage can be prevented in more than 80% of animals when pretreated with dipyridamole. The combination of aspirin and sulfinpyrazone has similar benefits.

During the 1970s a clinical trial called the Paris-1 Study evaluated the usefulness of dipyridamole combined with aspirin in about 2000 patients who had heart attacks. This study, unfortunately, included patients with old and very old heart attacks, ranging from six months to three years. Only patients with less than a six-month-old heart attack showed a significant reduction in death rate; this is not acceptable scientific evidence.

The combination of dipyridamole and aspirin was reevaluated in a clinical trial that ran from 1980 to 1984. Three thousand patients were treated within 30 days of their heart attacks and followed for 2 years. This combination was not of value in preventing deaths due to heart attacks, but it caused a 37% reduction in the recurrence of heart attacks. The combination of aspirin and dipyridamole prevents formation of blood clots in vein

grafts of patients who have had CABG. Recent trials have shown that 325 mg of aspirin is as good as the combination of aspirin and dipyridamole. Dipyridamole is not effective when used without aspirin.

Dipyridamole combined with aspirin (Aggrenox), has been shown to provide beneficial effects for secondary prevention after stroke. Dipyridamole should be added to aspirin if transient ischemic attacks (TIAs) occur during aspirin therapy. A randomized controlled trial indicated that a slow-release dipyridamole formulation of 200 mg plus aspirin 50 mg twice daily resulted in a highly significant reduction in the occurrence of stroke ($P=0.001$). The reduction for aspirin and dipyridamole for stroke was 37% versus 15% for dipyridamole alone and 18% for aspirin alone. Presently, the combination of aspirin and dipyridamole or clopidogrel appears to be the most effective and safest therapy for secondary prevention of stroke.

3. Clopidogrel

The drug action of clopidogrel is similar to ticlopidine, but with fewer adverse effects.

Dosage: 75 mg once daily.

Clopidogrel has been well tested in large randomized clinical trials such as CAPRIE, CURE, and CREDO. It is indicated for the reduction of cardiovascular events such as TIAs, stroke, MI, and vascular death. The CREDO trial showed that clopidogrel 300 mg administered from 6 to 24 h before percutaneous coronary intervention (PCI) caused a significant reduction in the risk of death, MI, or stroke.

4. Ticlopidine

Ticlopidine inhibits platelet clumping and can decrease the frequency of chest pain as well as correct abnormal ECG changes in patients with attacks of angina due to coronary heart disease. Studies implicate platelets as a major culprit in the causation of complications of coronary heart disease, including fatal or nonfatal heart attacks or angina. Ticlopidine was used in patients to prevent stroke if aspirin was not tolerated, but because of damage to white blood cells and serious platelet abnormality, the drug is now obsolete and replaced by clopidogrel.

5. Platelet Glycoprotein IIb/IIIa Receptor Blockers

There are numerous glycoprotein receptors on the surface of each of platelet (>75,000). Antagonism of these receptors blocks the final common pathways of activation-binding of fibrinogen to the platelet glycoprotein

receptors. This action prevents the platelet aggregation caused by thrombin, thromboxane A₂, ADP, and collagen.

These agents administered intravenously and by infusion prevent mortality and morbidity in patients with acute coronary syndromes who are undergoing PCI. They cause significant bleeding, however (see the chapter Antiplatelet Agents). Oral agents have a systemic effect and are generally counteracted only with hemodialysis. This is a major defect of new oral agents that so far have not shown beneficial effects.

C. Oral Anticoagulants (Warfarin, Coumadin)

1. Indications

Anticoagulants are not significantly effective in preventing a first or recurrent heart attack. They were used for this purpose from 1955 and abandoned in 1968. A recent trial has shown some beneficial effects, and they are used successfully for the treatment of clots in veins, particularly thrombi in the lower limbs (see the chapter Deep Vein Thrombosis). Anticoagulants are also used to treat clots in the lungs (pulmonary embolism) and the heart chambers (atrium or ventricle) preventing such clots from moving from the heart and blocking an artery elsewhere in the body such as in the legs or brain. Warfarin is commonly used for the prevention of stroke in patients with atrial fibrillation.

2. Actions

Warfarin, a 4-hydroxy coumarin compound, is the agent most widely used in the North America because of its predictable onset, duration of action, and excellent bioavailability. Warfarin is rapidly absorbed and reaches maximum plasma concentrations in about 90 minutes. It has a half-life of 36–42 h and circulates bound to plasma proteins with accumulation in microsomes of the liver.

Warfarin and other anticoagulants induce their anticoagulant effect by interfering with the cyclic interconversion of vitamin K and its 2, 3 epoxide, vitamin K epoxide. The posttranslation carboxylation of glutamate residues on the N-terminal regions of vitamin-K-dependent proteins to γ -carboxyglutamates is induced by the essential cofactor vitamin K. A decrease in vitamin K₂ limits the γ -carboxylation of the vitamin-K-dependent coagulant proteins (prothrombin, factor VII, IX, and X) and anticoagulant proteins (protein C and protein S). It also impairs their biologic function in blood coagulation. Inherited resistance to warfarin anticoagulation has been described in humans, albeit rarely.

3. Interactions

Patients on long-term warfarin therapy are sensitive to fluctuating levels of dietary vitamin K found in the green vegetables and nutritional fluid supplements that are rich in vitamin K. These reduce anticoagulant effects. Drugs that interact with warfarin are numerous and some are listed in Table 1. Drugs may influence the pharmacokinetics of warfarin by altering its metabolic clearance or its rate of absorption. They may further influence warfarin activity by inhibiting the synthesis of vitamin-K-dependent coagulation factors or increasing their metabolic clearance.

4. Dosage

A dose of warfarin 5 mg daily usually achieves adequate anticoagulant effect in 5 days. If more rapid anticoagulation is required a first dose of 10 mg followed by 5 mg daily until the INR is in the therapeutic range is recommended. It is desirable to administer the drug at night so that dosage changes can be made by a physician during the early or late afternoon following a morning blood test.

The anticoagulant effect of warfarin occurs within 24 h because of the inhibition of factor VII, which has a half-life of about 7 h; peak activity is delayed for about 84 h because of the longer half-lives of factors II, IX, and X. It is important to recognize, however, that reduction of anticoagulant activity may be counteracted by the thrombogenic effect of reduced protein C activity during the first 48 h of warfarin activity. Therefore, in patients administered heparin intravenously warfarin therapy should overlap for at least two days until the INR is within the desired range. A dose of 10 mg each night for two nights was originally advocated, but rare gangrene of the limbs has been noted.

Adjustment of dosage was originally regulated by the determination of the prothrombin time. This was replaced by the INR more than a decade ago. The INR is maintained at 2–3 for most cases of thrombosis. Bleeding due to oral anticoagulant activity is reversed by vitamin K1.

D. Heparin

I. Unfractionated Heparin

Heparin is a glycosaminoglycan composed of chains of alternating residues of D-glucosamine and uronic acid. Heparin has a molecular weight of 15,000 with approximately 50 monosaccharide chains.

This well known intravenous anticoagulant has been used worldwide for many years and has now been partially

replaced by low molecular weight heparin (LMWH) given subcutaneously. These new preparations have shown to be as effective as unfractionated intravenous heparin. They substantially reduce hospitalization costs because patients are able to administer these agents subcutaneously at home and avoid hospitalization.

The anticoagulant activity of heparin requires a cofactor, antithrombin III. A pentasaccharide sequence randomly distributed along one-third of the heparin chains mediates the interaction between heparin and antithrombin. The heparin antithrombin complex inactivates thrombin and thus prevents thrombin-induced activation of factors V and VII.

The dosage recommended is IV heparin 5000 to 10,000 U (100 U/kg) bolus then a continuous infusion of 12–25 U/kg for pulmonary embolism or deep vein thrombosis. For MI, a lower dose is recommended of 60 U/kg bolus and infusion, 12 U/kg to maintain a PTT of 50–70 seconds.

The main complication of heparin therapy is hemorrhage, but between 5 and 10 days of heparin therapy heparin-induced thrombocytopenia may develop. When administered for more than one month, heparin may cause osteoporosis.

2. Low Molecular Weight Heparin

LMWHs are fragments of unfractionated heparin produced by chemical or enzymatic depolymerization processes that yield glycosaminoglycan chains with a mean molecular mass of approximately 5000. Because binding to endothelial cells and to plasma proteins is chain-length dependent with longer heparin chains having greater affinity than shorter chains, LMWHs have a much longer half-life than IV heparin. The absence of protein binding in the LMWHs contributes to the excellent bioavailability versus IV heparin. They also have a more predictable anticoagulant response when administered in fixed doses. Beneficial effects of LMWHs on mortality and morbidity in patients with acute coronary syndrome are equal to that of unfractionated heparin.

Dosage: Enoxaparin 1 mg/kg subcutaneously every 12 h or 1.5 mg/kg once a day. Dalteparin 120 IU/kg subcutaneously (but not more than 10,000 IU) every 12 h.

LMWHs should be avoided in patients with significant renal dysfunction (serum creatinine > 2 mg/dl), 176 $\mu\text{mol/l}$, because these drugs are excreted by the kidney.

3. Direct Thrombin Inhibitors

These include bivalirudin, hirudin, argatroban, and an oral agent ximelagatran. These agents bind thrombin

and block its interaction with substrates, thus preventing fibrin formation, thrombin-mediated activation of clotting factors, and thrombin-induced platelet aggregation. These agents have distinct advantages over heparin: they produce a more predictable anticoagulant effect because they do not bind to plasma proteins, they are not neutralized by platelet factor IV, and they inactivate fibrin-bound thrombin in addition to the fluid phase of thrombin.

Hirudin is a naturally occurring specific thrombin inhibitor. It is a 65-amino-acid polypeptide that was isolated from the saliva of the leech *Hirudo medicinalis* more than 30 years ago. Recombinant techniques have provided the agent for clinical use.

The GUSTO IIb trial indicated that a combination of hydrogen and streptokinase is a promising alternative to t-PA with heparin. Death or reinfarction occurred in 8.6% of patients treated with hirudin versus 14.4% of patients treated with heparin ($P=0.004$). Hirudin is eliminated by the kidneys and should not be used in patients with impairment of renal function.

Bivalirudin had beneficial effects that were similar or modestly better than heparin in small clinical trials in patients with acute coronary syndrome and those undergoing PCI, but superiority over heparin needs to be tested in large randomized trials. This agent binds reversibly to thrombin, which may explain the lower adverse effects compared with hirudin and heparin.

The plasma half-life of intravenous administration of bivalirudin is 24 minutes. This short half-life is an advantage over hirudin. Also, the drug is only partially excreted by the kidneys, and this allows a greater measure of safety. In a randomized clinical trial in patients undergoing PCI, bivalirudin reduced the risk of death or MI 30% at 50 days with 60% reduction in major bleeding.

Ximelagatran is the first in a new class of oral direct thrombin inhibitors under investigation for prevention and treatment of thromboembolic events. After oral administration the drug is rapidly metabolized to its active form, melagatran, a direct thrombin inhibitor of soluble and fibrin bound thrombin.

In the ESTEEM trial, a placebo-controlled, double-blind randomized multinational study of 1883 patients

with acute ST segment elevation or non-ST segment elevation MI was undertaken. The drug significantly reduced the risk for the primary end point (all-cause death, nonfatal infarction, and severe recurrent ischemia) compared with placebo from 16.2% to 12.7%, $p=0.036$. All patients received aspirin. No serious clinical adverse outcomes were observed but mild elevation of liver enzymes occurred rarely with ximelagatran administration. In the SPORTIF III trial alanine aminotransferase elevations reached greater than five times the upper limit of normal in 3.4% of patients, and caution is required. Patients should be carefully monitored for hepatotoxicity which limits general application of this drug. Similar acting agents should be sought (see chapter Atrial Fibrillation).

BIBLIOGRAPHY

- Abrams, J., Frishman, W. H., Bates, S. M. et al. Pharmacologic options for treatment of ischemic disease. In *Cardiovascular Therapeutics*, second edition. E. M. Antman, ed. W. B. Saunders, Philadelphia, 2002.
- Becker, R. C. Novel constructs for thrombin inhibition. *Am. Heart J.*, 149:S61-S72, 2005.
- ESTEEM: Wallentin, L., Wilcox, R. G., Weaver, W. D. et al. For the ESTEEM Investigators. Oral ximelagatran for secondary prophylaxis after myocardial infarction: The ESTEEM randomized controlled trial. *Lancet*, 362:789-97, 2003.
- Executive Steering Committee on the Behalf of the SPORTIF III Investigators. Stroke prevention with oral direct thrombin inhibitor ximelagatran compared with warfarin in patients with non-valvular atrial fibrillation (SPORTIF III): Randomized controlled trial. *Lancet*, 362:1691-1698, 2003.
- Halperin, J. L. Ximelagatran: Oral direct thrombin inhibition as anticoagulant therapy in atrial fibrillation. *J. Am. Coll. Cardiol.*, 45:1-9, 2005.
- Hirsh, J., Warkentin, T. E., Raschke, R. et al. Heparin and low molecular weight heparin: Mechanisms of action, pharmacokinetics, dosing considerations monitoring, efficacy and safety. *Chest*, 114:489S-506S, 1998.
- Rentrop, K. P., Blanke, H., Karsch, K. R. et al. Subjective intracoronary thrombolysis in acute myocardial infarction and unstable angina pectoris. *Circulation*, 63:307, 1981.
- Steinhubl, S. R., Berger, P. B., Mann, J. T. et al. Early and sustained dual oral antiplatelet therapy following percutaneous coronary intervention. *JAMA*, 288:2411-20, 2002.
- Topol, E. J. Aspirin with bypass surgery-from taboo to new standard of care. *N. Engl. J. Med.*, 347:1359, 2002.

Blood Pressure

- I. Historical Review
- II. Systolic and Diastolic Blood Pressure
- III. Classification
- IV. Normal Fluctuations in Blood Pressure
- V. Finger Cuff Method of Penaz
- VI. Technique and Pitfalls of Measurement
- VII. Effects of High Blood Pressure

GLOSSARY

- aneurysm** a severe weakening of the wall of an artery or heart muscle leading to ballooning of the wall of the vessel or heart chamber.
- arrhythmia** general term for irregularity or rapidity of the heartbeat, an abnormal heart rhythm.
- arteriosclerosis** loss of elasticity and hardening of the artery due to several causes, particularly age change and deposits of calcium; an artery with pipe-like rigidity.
- heart failure** failure of the heart to pump sufficient blood from the chambers into the aorta; inadequate supply of blood reaches organs and tissues.
- myocardial infarction** death of an area of heart muscle due to blockage of a coronary artery by blood clot and atheroma; medical term for a heart attack.

THE HEART PUMPS BLOOD DIRECTLY INTO blood vessels called arteries, which are like a series of pipes. The narrower the artery, the greater the resistance or impedance to the flow of blood; therefore, the heart must pump with greater force. The amount of force the blood is pumped from the heart through the arteries is the blood pressure.

I. HISTORICAL REVIEW

A. The Beginning of Sphygmomanometry

Reverend Stephen Hales is the father of sphygmomanometry. During his seven-year course in theology at Corpus

Christi (Bene't College), Cambridge in 1733, mathematics and science were added to basic theology and philosophy. It was at Cambridge where he initially experimented on pressure, resistance, and flow. He later became curate of Teddington outside of London, received his BA, and was awarded an MA at Cambridge and Bachelor of Divinity from Oxford.

Some years later he commenced his experimental scientific work on the circulation of blood. He conducted more than 25 experiments on dogs and horses. Figure 1 is an artist's impression of Hale's experiments to determine the blood pressure of a horse. His observations were published in Volume II of the *Statistical Essays* in 1733:

... in the summer I caused the mare to be tied down alive on her back; having laid open the left crural artery about three inches from her belly, I inserted into it a brass pipe whose bore was one sixth of an inch in diameter. ... I fixed a glass tube of nearly the same diameter which was 9 feet in length: then untying the ligature of the artery, the blood rose in the tube 8 feet 3 inches perpendicular above the level of the left ventricle of the heart; ... when it was at its full height it would rise and fall at and after each pulse 2, 3, or 4 inches. ..."

Figure 2 is a page from *Haemastatics* showing his measurement for correlating blood volume with the blood pressure. After this, it appears that there were no advances for the next 100 years.

B. Further Advances

Poiseuille was a physician and a physicist who introduced the mercury manometer to the world in 1833. He won the gold medal of the Royal Academy of Medicine for his doctoral designation of the management of arterial blood pressure by means of the mercury manometer connected to a cannula that was inserted directly into an artery. Around 1881 Samuel von Basch further advanced blood pressure measurements with the use of an inflatable



FIGURE 1 Rev. Stephen Hales and an assistant measuring the blood pressure in a horse. (From the National Library of Medicine. Literary source, *Medical Times*, 1944. Courtesy of National Library of Medicine.)

Hæmastatics.

The several Trials.	The Quantities of Blood let out in Wine Measure.		The several Heights of the Blood after these evacuations	
	Quarts	Pints	Feet	Inches
1	0	0	8	3
2	1	0	7	8
3	2	0	7	2
4	3	0	6	6 ½
5	4	0	6	10 ½
6	5	0	6	10 ½
7	6	0	5	8 ½
8	7	0	4	8 ½
9	8	0	3	3
10	8	1	3	7 ½
11	9	0	3	10
12	9	1	3	6 ½
13	10	0	3	9 ½
14	10	1	4	8 ½
15	11	0	3	8
16	11	1	3	10 ½
17	12	0	3	9 ½
18	12	1	3	7 ½
19	13	0	3	2
20	13	1	4	½
21	14	0	3	9
22	14	1	3	3 ½
23	15	0	3	4 ½
24	15	1	3	1
25	16	0	2	4

These 5 Ounces lost in preparing the Artery.

By this time there is a Pint lost in making the several Trials, which is not allowed for in this Table.

There was about a Quart lost in making the several Trials, so there flowed out in all seventeen Quarts, and half a Pint after the last Trial, when she expired. This whole Quantity of Blood was equal to 1185.3 cubick Inches.

3 5. We

FIGURE 2 A page from Hale's 'Haemastatics'. (From the National Library of Medicine. Literary source, *Original*. Courtesy of National Library of Medicine.)

rubber bag with water (see Fig. 3). In 1889, Potain substituted air for water and used a rubber bulb for compression of the pulse. He recorded the pressure with a portable aneroid manometer, but the measurements were unreliable.

C. Advancements Leading to Current Methods

Scipione Riva-Rocci, in 1896, reported a noninvasive method of obtaining blood pressure that led to our current technique (see Fig. 4). He reported the appearance of definite and pronounced oscillations in the column of mercury which coincided with the appearance of the radial pulse. This was taken as the systolic pressure. The

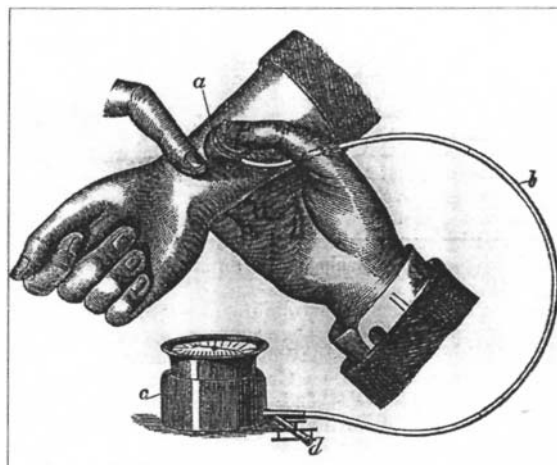

FIGURE 3 A later sphygmomanometer by Von Basch (1883). (Photo source, National Library of Medicine. Literary source, Basch, S.S.R., von (1883). *Ein-Metall-sphygmomanometer*. *Wien. Med. Woch.*, 33(22), 674. Courtesy of National Library of Medicine.)

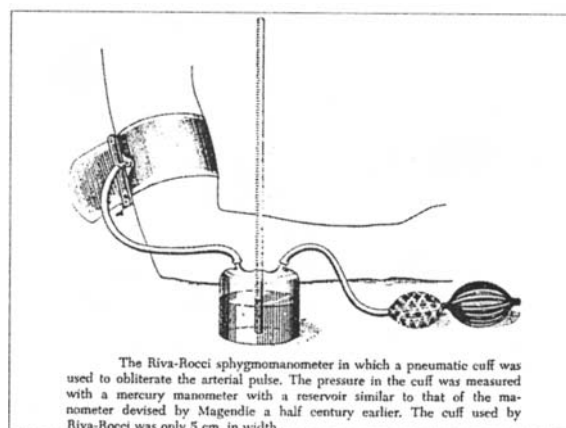

FIGURE 4 Riva-Rocci's sphygmomanometer. (Photo source, University of Central Florida. Literary source, Burch, G. and DePasquale, N. (1962). *Primer of Clinical Measurements of Blood Pressure*, Fig. 14, p. 29, St. Louis: C.V. Mosby. With permission.)

diastolic pressure was recorded when the level of the mercury column changed from large to small oscillations. A major defect in Riva-Rocci's technique was the use of a narrow 5-cm arm band. German pathologist Friedrich Von Recklinghausen later corrected this defect by introducing a 12-cm wide arm band in 1901.

By 1905, Nicolai Korotkoff further advanced Riva-Rocci's ideas. In 1898 Korotkoff obtained his medical degree from the University of Moscow and pursued a career in vascular surgery. As a surgeon, he often used a stethoscope to differentiate between a solid mass and arterial aneurysm. He was therefore concerned with sounds made by arteries.

His main conclusions were derived from the simple observation that a perfectly constricted artery under normal conditions does not emit any sounds. Thus, he proposed the sound method for measuring blood pressure on humans. He used the Riva-Rocci sleeve on the middle third of the arm. At first he observed no sounds, but as the mercury in the manometer dropped to a certain height the first short faint tones appeared. He called these tones the maximum blood pressure. When all sounds disappeared, the manometer reading reflected the minimum blood pressure. The accuracy of Korotkoff's "sound method" has stood the test of time. It is presently used worldwide with acceptable clinical accuracy; nothing has changed except for a varied cuff size relative to the arm width.

II. SYSTOLIC AND DIASTOLIC BLOOD PRESSURE

Everyone has a blood pressure, but what does that mean? The pressure in the arteries when the heart contracts (systole) is called systolic blood pressure. This is usually less than 140 millimeters of mercury (mmHg). The pressure in the arteries when the heart is relaxed (diastole) is called diastolic pressure, and this is usually less than 90 mmHg in adults.

Here is another way of looking at blood pressure. Each contraction of the heart causes blood to be pushed (propelled) through the arteries in the form of a pulse wave; thus the flow of blood in the arteries is pulsatile. A wave must have a crest and a trough. The crest is caused when the heart contracts (systole) and is the highest pressure. Systolic blood pressure coincides with the first Korotkoff sounds heard with the stethoscope over the brachial artery at the cubital fossa just below the level of the inflated cuff on the arm. The trough is caused when the heart relaxes (diastole), producing the lowest pressure, or diastolic pressure at which instant all Korotkoff sounds disappear, and no sounds are heard with the stethoscope.

Resistance in the arteries against which the heart must pump is called the total vascular resistance. If the total vascular resistance increases, blood pressure increases. This vascular resistance is increased when the arteries are constricted by disease, aging, drugs, or naturally occurring chemicals in the body such as adrenaline and noradrenaline. Sudden alarming stress, fright, and situations that provoke sudden anxiety may cause secretion of excess adrenaline and noradrenaline, which causes sudden and considerable elevation in systolic blood pressure. In these situations the systolic blood pressure, which may have been 135 mmHg, may shoot up suddenly, and within minutes be 175–200 mmHg.

The amount of blood expelled by the heart into the arteries in one minute is called the cardiac output and is about 5 L/minute. Blood pressure is equal to the total vascular resistance multiplied by the cardiac output. Hypertension is the medical term for high blood pressure and has nothing to do with excessive nervous tension.

High blood pressure in individuals older than age 18 is defined as a systolic blood pressure of greater than 140 mmHg and/or a diastolic blood pressure of greater than 90 mmHg based on the average of two or more readings taken at each of two or more visits after an initial screening (average of at least four readings taken days or weeks apart).

III. CLASSIFICATION

The classification of blood pressure (BP) for adults age 18 years and older as given in the Seventh Report of the Joint National Committee on Prevention, Detection, Evaluation, and Treatment of High Blood Pressure (JNC 7) is as follows:

- Normal: BP < 120 systolic; diastolic <80 mmHg
- Prehypertension: 120–139; diastolic 80–89
- Stage 1 hypertension: 140–159; diastolic 90–99
- Stage 2: >160; >100

IV. NORMAL FLUCTUATIONS IN BLOOD PRESSURE

A. Marked Variability

Marked variability in blood pressure is normal. It varies from minute to minute and from day to day like the waves of a sea, fluctuating with the force of the prevailing winds. Blood pressure is different at night, during sleep, and the early morning, fluctuating considerably during the day. The systolic pressure may differ from 5 to 15 mmHg during these moments.

Ambulatory blood pressure recordings may be needed in some individuals to verify the correct levels of hypertension. The blood pressure readings in a doctor's office or clinics are often higher than they are in a home setting. Blood pressure readings taken at home are important, but it is necessary to have the pressure recorded outside the home in different settings to arrive at conclusive documentation that high blood pressure is indeed present. The variability of the blood pressure recorded on repeated measurements, both at a single visit and on separate occasions at a clinic or physician's office, is much greater than most doctors and patients realize. Individuals are

often falsely labeled normotensive or hypertensive. Because of the lifelong commitment to antihypertensive medications, the diagnosis must be carefully established, particularly with borderline hypertension. Because of this marked variability in recorded blood pressure from day to day, individuals with borderline hypertension may require observation for up to two years before a correct diagnosis is made and the commencement of medications.

B. Daytime and Nighttime Variability

Daytime blood pressure is mainly determined by the degree of physical and mental activity and is under the control of baroreflexes that operate through adjustments in heart rate and peripheral vascular resistance. The usual fall in blood pressure at night is a result of sleep and inactivity rather than the time of day; pressure falls during the day if an individual sleeps. Blood pressure may fall 10–20 mmHg during sleep as the baroreflex sensitivity decreases sympathetic nervous activity.

There is a usual abrupt rise in blood pressure within minutes of arising in the early morning caused by catecholamine release; it is a critical period that coincides with an increased incidence of sudden cardiac death, stroke, and myocardial infarction. An increase in catecholamines increases blood pressure, which causes increased stickiness of platelets that may aggregate and predispose the formation of clots in coronary arteries or arteries that supply the brain. The activity of the heart increases as more oxygen is required to cope with the stimulation caused by the release of catecholamines.

Beta-blocking drugs counteract the deleterious effects of catecholamines, and they have been shown in sound, randomized clinical trials to decrease the early morning incidence of sudden deaths and fatal and nonfatal myocardial infarction. These sudden deaths are not prevented by aspirin or antiplatelet agents. This information is probably known to less than 25% of practicing doctors worldwide.

C. White-Coat Hypertension

The definition of white-coat hypertension awaits clarification. The prevalence in a population of untreated hypertensive patients has been reported to vary from 12% to as high as 53%. It is estimated, however, that about 10% of these individuals have genuine hypertension; they do not require medication and their hypertension should be defined by blood pressures taken outside the physician's office. Home measurements and the use of finger blood pressure measurements should be used.

The acute elevation of blood pressure in the office setting is presumably a conditional reflex that increases sympathetic nervous arousal each time the blood pressure is taken by the physician. In a study of 292 patients with diastolic blood pressures ranging from 90 to 104 mmHg during multiple physician's visits over a period of 6 years, 21% had persistently normal readings during a 24-h ambulatory recording.

White-coat hypertension has been observed in more than 20% of individuals diagnosed as hypertensive, including elderly patients with systolic hypertension. In one study approximately 50% of patients who were not believed to be responding to medications based on physician's blood pressure readings were shown on ambulatory monitoring to have controlled blood pressures. Overuse of medications in this large population of individuals is a real problem.

D. Pseudohypertension

Pseudohypertension is a false reading of high blood pressure. It is not unusual for this to occur in patients with arteriosclerosis, calcification, and diffuse hardening of the arteries, particularly in the upper limbs. With hardening of the arteries, the rigid, pipe-like arteries resist compression by the sphygmomanometer cuff, and the pressure in the cuff wrapped around the arm fails to constrict and collapse the brachial artery. Because of this, blood continues to flow through the artery into the forearm causing a false high reading. A reading in the range of 180 to 220 is not unusual.

Pseudohypertension should be excluded in elderly individuals whose brachial arteries characteristically feel rigid and pipe-like and in individuals who have no effects of hypertension after several years of abnormal readings such as evidence of hypertension in the retina or cardiovascular or renal disease. Pseudohypertension may also be suspected in these individuals with blood pressure apparently resistant to therapy and in those who develop dizziness and lightheadedness related to change in posture. Recordings over a period of weeks in the home, particularly with a simple finger blood pressure measurement, should resolve the diagnosis of pseudohypertension in virtually all patients. An automatic oscillometric recorder may be required to verify the blood pressures, and rarely, a direct intra-arterial reading may be necessary.

E. Home Measurements

Home measurements of blood pressure are crucial for the adequate management of hypertension in more than 33%

of hypertensives. A record of home measurements verified by measurements outside the physician's office is an important strategy to prevent overmedication.

Measurements in the home have been shown to give virtually all of the information provided by ambulatory blood pressure monitoring. The home or ambulatory readings have been shown in studies to be comparable, reproducible, and considerably lower than office readings. Home blood pressure measurements are strongly indicated for the following:

- To assist the physician with the diagnosis of borderline or stage 1 hypertension (see stages given above in Section III)
- To exclude short term hypertension that may occur for a few months because of stressful situations at work or at home and do not require lifelong medications
- To exclude white-coat hypertension
- To exclude pseudohypertension in the elderly
- To monitor response to therapy to avoid the addition of another antihypertensive agent to achieve control, thus preventing overmedication for so-called uncontrolled blood pressure in an office setting

V. FINGER CUFF METHOD OF PENAZ

This method works on the principle of the unloaded arterial wall. Arterial pulsation in a finger is detected by a photoplethysmograph under a pressure cuff. The plethysmograph's output drives a servoloop which changes the cuff pressure to maintain constant output so that the artery is held in the partially opened state. The pressure oscillations in the cuff are measured and resemble the intra-arterial pressure wave in most individuals tested. Finometer and Portapres recorders are available and are useful for the diagnosis of pseudohypertension that may occur in the elderly who may be overmedicated because of the finding of high blood pressure readings obtained with the usual cuff method.

VI. TECHNIQUE AND PITFALLS OF MEASUREMENT

The cuff size must be appropriate for the blood pressure measurement to be accurate. The arm and the mercury or aneroid manometer must be at the same level as the heart. The patient should be seated for about 5 minutes with the back supported and with the arm supported at heart level. If the arm is not supported than readings are

approximately 8 mmHg higher than those taken with arm supported. If the back is not supported, readings may be as much as 10 mmHg higher because of the isometric exertion needed to support the body and arm.

Inflate the bladder quickly to a pressure about 20 mmHg above the systolic pressure as recognized by disappearance of the radial pulse. Inflating the bladder too slowly may cause errors. Deflate at a rate of 2–4 mmHg per second; a slower rate of deflation may cause false high readings. If a second blood pressure reading is to be taken, the cuff must be completely emptied of air and the arm band removed and reapplied. Many erroneous readings are obtained if proper technique is not stringently applied.

VII. EFFECTS OF HIGH BLOOD PRESSURE

A moderate degree of hypertension for more than five years causes severe damage to vital organs. Complications include:

1. Hypertrophy or enlargement of the heart
2. Heart failure that causes fluid to accumulate in the lungs and the legs manifested by severe shortness of breath
3. Myocardial infarction
4. Atrial fibrillation, a serious arrhythmia which causes palpitations, leads to stroke, and requires a bothersome commitment to anticoagulation with blood thinners
5. Stroke that may be thrombotic or hemorrhagic
6. Damage to the kidney that leads to renal dysfunction and renal failure
7. Aortic aneurysm prone to rupture

See the chapter Hypertension for causes of hypertension and drug and nondrug treatment.

BIBLIOGRAPHY

- Aram, V., Chobanian, M. D., Bakris, G. L., and the National High Blood Pressure Education Program Coordinating Committee et al. The seventh report of the joint national committee on prevention, detection, evaluation, and treatment of high blood pressure. The JNC 7 Report. *JAMA*, 289:2560–2571, 2003.
- Clarke-Kennedy, A. E., Stephen Hales, D. D., F.R.S. *Br. Med. J.*, 2:1656, 1977.
- Editorial. Stephen Hales: Father of hemodynamics. *Med. Times*, 72:315, 1944.
- James, G. D., Pickering, T. G., Yee, L. S. et al. The reproducibility of average ambulatory, home and clinic pressures. *Hypertension*, 11:545–49, 1988.
- Julius, S. Home blood pressure monitoring: Advantages and limitations. *J. Hypertens.*, 9 (Supplement 3):S41–S46, 1991.
- Kaplan, N. M. Measurement of blood pressure. In *Clinical Hypertension*, Williams & Wilkins, Baltimore, MD, 1994.

- Khan, M. Gabriel Hypertension. In *Cardiac Drug Therapy*, W. B. Saunders, Philadelphia, 2003.
- Mejia, A. D., Egan, B. M., Schork, N. J. et al. Artifacts in measurement of blood pressure and lack of target organ involvement in the assessment of patients with treatment-resistant hypertension. *Ann. Intern. Med.*, 112:270-77, 1990.
- Messerli, F. H., White, W. B., and Staessen, J. A. If only cardiologists did properly measure blood pressure. *J. Am. Coll. Cardiol.*, 40:2201-3, 2002.
- Penaz, J. Photoelectric measurement of blood pressure, volume and flow in the finger. Digest 10th International Conference Med. Biol. Eng. Dresden, Germany. p. 104, 1973.
- Pickering, T. G. Ambulatory monitoring in the definition of hypertension *J. Hypertens.*, 10:401-9, 1992.
- Pickering, T. G. Blood pressure measurement issues. In *Hypertension*. S. Oparil and M. A. Weber, eds. W. B. Saunders, Philadelphia, 306, 2000.
- Pickering, T. G., James, G. D., Boddie, C. et al. How common is white coat hypertension? *JAMA*, 259:225-28, 1988.
- Stewart, M. J., and Padfield, P. L. Blood pressure measurement: An epitaph for the mercury sphygmomanometer? *Clin. Sci.*, 83:1-12, 1992.
- Zweifler, A. J., and Shahab, S. T. Pseudohypertension: A new assessment. *J. Hypertens.*, 11:1-6, 1993.

Brugada Syndrome

- I. Clinical Features
- II. Perspective

GLOSSARY

- Brugada** P. Brugada described the syndrome and its electrocardiographic changes.
- sodium cardiac channels** cardiac cells possess channels through which sodium and potassium flow inward and outward; the exchange of positive and negative charge produces a small current.
- syncope** temporary loss of consciousness caused by lack of blood supply to the brain; fainting describes a simple syncopal attack.
- ventricular fibrillation** the heart muscle does not contract but quivers; therefore, there is no heartbeat (cardiac arrest) and no blood is pumped out of the heart; death occurs within minutes if the abnormal heart rhythm is not corrected.

PEDRO AND JOSEP BRUGADA DESCRIBED A cardiac condition in 1992 characterized by a typical ECG pattern and a high incidence of sudden death particularly in younger individuals. The Brugada syndrome is a congenital disorder of sodium cardiac channel function. It is prevalent in Southeast Asia. Rare deaths have occurred during sleep sometimes associated with nightmares. The syndrome has variety of names in different countries: Bangungut (scream followed by sudden death) in the Philippines, Lai Tai in Thailand, and Pokkuri (unexpected death at night) in Japan. Apparently in Thailand unexplained sudden cardiac death is the leading cause of death in young men, and approximately 40% of these patients have a family history of sudden deaths; an estimated incidence of 1 sudden death per 1000 persons per year. The Brugada VCG phenotype has been estimated to be up to 1.4% in Japan. The typical ECG pattern may be intermittent, and is found in 0.15% of Japanese

adults, which is associated with a greater than 50-fold increase in the risk of unexpected death; the incidence is reportedly ninefold higher in Japanese men than in women.

Although much less common than in south-eastern Asia this syndrome is not rare in western countries and in North America.

I. CLINICAL FEATURES

Symptoms, particularly syncope and sudden death, usually appear between the ages of 40 and 50. These symptoms occur with no warning. In one study of 163 patients in which ventricular fibrillation occurred in 22% percent, the following observations were made: 12:1 male to female ratio, 58% of Asian origin, and mean age at first abnormal heart rhythm detected was 22–65, but occurred more often in the 40–50 age group. Most of these patients had a family history of syncope, sudden death, or abnormal ECG changes.

In Brugada syndrome sudden cardiac death is often preceded by several episodes of syncope. Brugada syndrome is believed to cause approximately 30% of all cases of ventricular fibrillation of unknown cause. Remme et al. reported that the vast majority of patients showed no evidence of structural heart disease but the electrical system has a minor derangement, probably in the bundle of His–Purkinje electrical conducting system that in some individuals can trigger ventricular fibrillation and death.

In these patients the ECG is diagnostic and shows a distinctive type of right bundle branch block. The ST segment is elevated in chest leads V1, V2, and V3 where the right bundle branch pattern is usually seen. Figures 1–5 show the ECG tracing in a patient with Brugada syndrome. The elevated ST segment has a curious convex curve or a coved and saddle back shape. The ECG is abnormal but the heart is structurally normal. Antiarrhythmic agents are not effective in preventing ventricular

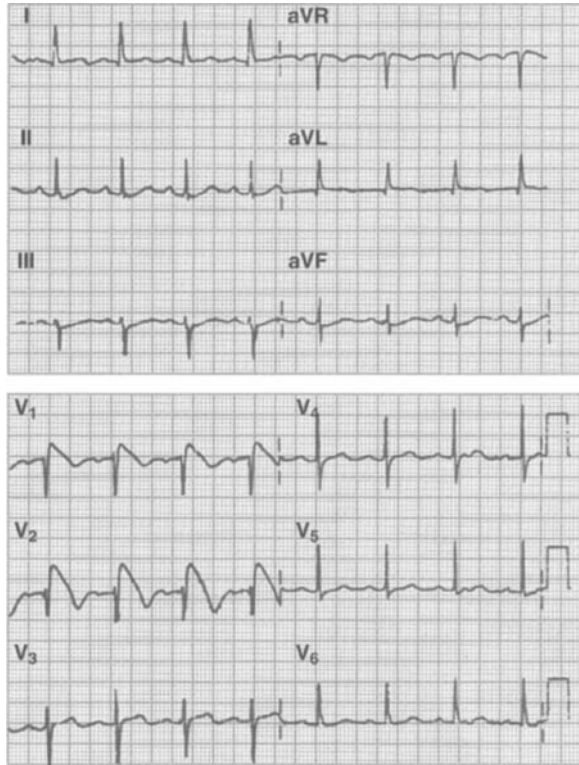

FIGURE 1 Twelve-lead electrocardiogram (ECG) of a patient with Brugada syndrome. The ECG is characterized by a right bundle branch block pattern and persistent ST elevation in V_1 through V_3 . (From Brugada, J., and Brugada, P., (1998). *Circulation*, 97:457–460. By permission of the American Heart Association, Inc.)

fibrillation in these patients and implantation of a cardioverter defibrillator is advisable to prevent sudden death.

II. PERSPECTIVE

The exact mechanism of the electrocardiographic changes and the development of ventricular fibrillation and sudden death remain undetermined. Electrically active cardiac cells possess sodium channels; an outward sodium current is counterbalanced by an inward sodium current. It appears that in this syndrome the inward current is attenuated and some of the electrocardiographic features can be partly explained based on changes in sodium currents. The

syndrome is a disorder of sodium cardiac channel function that triggers the electrocardiographic changes and malignant arrhythmias, particularly ventricular fibrillation. Mutations in a gene responsible for the sodium channel have been identified in some families with this syndrome. More than three different mutations on the cardiac sodium channel gene *SCN5A* on chromosome 3 have been described. Mutations on other genes are being sought. Further research is required in this area and its results are of extreme importance to prevent deaths in young individuals.

BIBLIOGRAPHY

- Antzelevitch, C., Brugada, P., Brugada, J., Brugada, R., Towbin, J. A., and Nademanee, K. Brugada syndrome: 1992–2002: A historical perspective. *J. Am. Coll. Cardiol.*, 41:1665–1671, 2003.
- Antzelevitch, C., Brugada, P., Borggrefe, M. et al. Brugada syndrome: Report of the second consensus conference: Endorsed by the Heart Rhythm Society and the European Heart Rhythm Association. *Circulation*, 111:659–670, 2005.
- Belhassen, B., Viskin, S., and Antzelevitch, C. The Brugada syndrome: Is ICD the only therapeutic option? *Pacing Clin. Electrophysiol.*, 25:1634–1640, 2002.
- Brugada, P., and Brugada, J. Right bundle branch block, persistent ST-segment elevation and sudden cardiac death: A distinct clinical and electrocardiographic syndrome. *J. Am. Coll. Cardiol.*, 20:1391–96, 1992.
- Eckardt, L., Probst, V., Smits, J. P. P. et al. Long-term prognosis of individuals with right precordial ST-segment-elevation Brugada syndrome. *Circulation*, 111:257–263, 2005.
- Ikeda, T., Sakurada, H., Sakabe, K. et al. Assessment of noninvasive markers in identifying patients at risk in the Brugada syndrome: insight into risk stratification. *Journal American college cardio* 37: 1628–34, 2001.
- Makita, N., Shirai, N., Wang, D. W. et al. Cardiac sodium channel dysfunction in Brugada syndrome is aggravated by beta [1]-subunit. *Circulation*, 101:54–60, 2000.
- Matsuo, K., Akahoshi, M., Nakashima, E. et al. The prevalence, incidence and prognostic value of the Brugada-type electrocardiogram. *J. Am. Coll. Cardiol.*, 38:765–770, 2001.
- Naccarelli, G. V., and Antzelevitch, C. The Brugada syndrome: Clinical, genetic, cellular and molecular abnormalities. *Am. J. Med.*, 110:573–81, 2001.
- Remme, C. A., Wever, E. F. D., Wilde, A. A. M. et al. Diagnosis and long-term follow-up of Brugada syndrome in patients with idiopathic ventricular fibrillation. *Eur. Heart J.*, 22:400–409, 2001.

Bundle Branch Block

- I. Right Bundle Branch Block
- II. Left Bundle Branch Block

GLOSSARY

heart failure failure of the heart to pump sufficient blood from the chambers into the aorta; inadequate supply blood reaches organs and tissues.

hypertrophy increase in thickness of muscle.

myocardial infarction death of an area of heart muscle due to blockage of a coronary artery by blood clot and atheroma; medical term for a heart attack or coronary thrombosis.

sudden cardiac death death from cardiac causes that occurs instantaneously or within the hour of the onset of symptoms; the hallmark features are an instantaneous and unexpected time and mode of cardiac death.

EACH CONTRACTION OF THE HEART IS PRECEDED by excitation waves of electrical activity that originate in a unique pacemaker called the sinoatrial (SA) node, which provides individuals with an automatic, infinitesimal current that sets the electrical activity and contractions of the heart. The electrical discharge from the SA node passes across the atrium and reaches the atrioventricular (AV) node, see Fig. 1. From the AV node the current is conducted to the ventricle through two bundles, a large left bundle and a thinner right bundle (see the chapter Anatomy of the Heart and Circulation).

Many myocardial diseases are associated with bundle branch block. The prognosis of bundle branch block reflects the underlying myocardial disease and is therefore variable. Mass electrocardiographic surveys indicate that many apparently healthy individuals have bundle branch block.

I. RIGHT BUNDLE BRANCH BLOCK

The right bundle branch is the continuation of the penetrating AV bundle and runs as a single discrete bundle

beneath the endocardium of the ventricular septum to the base of the anterior papillary muscle. The bundle then runs in the moderator band to form a rich anastomosing network of conducting fibers throughout the right ventricle. The subepicardial location and discrete nature of the bundle branch of the rim of the right ventricular outflow makes it vulnerable to trauma from catheters. Because of its discrete nature, the bundle is easily damaged by several diseases including focal hypoplasia that causes congenital right bundle branch block, anteroseptal myocardial infarction that commonly affects the ventricular septum, and right ventricular hypertrophy associated with diffuse subendocardial fibrosis.

The electrical bundles that take the electrical impulses to the right ventricle are damaged or do not conduct the impulse; the electrical impulses fail to reach the right ventricle. Complete right bundle branch block occurs when there is a complete interruption of conduction to the right ventricle through the right bundle branch. Diagnosis is made only from the ECG. Figure 2 shows the electrocardiographic genesis of the QRS complex in right bundle branch block (RBBB). Figures 3A, and B show a normal ECG compared with one that depicts the features of RBBB. Note that the QRS complex is wide and can have a duration of greater than 120 ms, whereas in a normal tracing the QRS duration is 80–110 ms. This happens because it takes more time for the electrical current to be conducted from the AV node through the left bundle then for the right ventricle to receive the current.

A. ECG Criteria for Diagnosis of Right Bundle Branch Block

The ECG criteria necessary for diagnosis include QRS duration greater than 120 ms, M-shaped complex in chest leads V1 and V2, and slurred S wave in lead I and V6 with an amplitude greater than the R wave in lead I and V6.

B. Causes of Right Bundle Branch Block and Associations

1. In Normal Individuals

Right bundle branch block is a normal finding in adults of all ages. Many individuals with RBBB have no evidence of structural heart disease and isolated RBBB occurs more commonly than isolated left bundle branch block (LBBB). An incidence of about 2% per 1000 was observed in a study of 122,000 apparently normal Air Force personnel and applicants age 16–55; at age 40–55 the incidence was about 3%. The cause of all of RBBB in otherwise healthy individuals remains unclear. It is clear that in individuals age 15–50 with RBBB and no evidence of structural heart disease the prognosis and the survival time are not much different from individuals in the general population without RBBB. Apparently there is an increased incidence of RBBB among individuals who live at high altitude.

In a follow up of 855 men 50 years or older, the prevalence of bundle branch block increased from 1% at age 50–17% at age 80, with RBBB in 13% and LBBB in about 7%. This suggests that the occurrence of bundle branch block after the age of 45 is caused by slowly progressive degenerative conduction tissue disease; the long slender right bundle is vulnerable to processes related to aging.

RBBB, therefore, is common and when observed in individuals with structurally normal hearts it is nonprogressive. This condition does not affect the patient's lifestyle and causes no symptoms. It does not lead to heart attacks or heart failure and requires no treatment. A pacemaker is never required in patients with structurally normal hearts.

2. In Individuals with Coronary Artery Disease

Acute and chronic coronary artery disease (angina and old or acute myocardial infarction) are common causes of RBBB, and reportedly it is the most common perioperative conduction defect observed after coronary artery bypass surgery.

In patients with acute myocardial infarction, RBBB has been observed in greater than 10% (3–29%) and is commonly associated with another conduction block, left anterior hemiblock. This is associated with an adverse outcome of a large area of infarction, with an in-hospital mortality of greater than 20% and one-year mortality of greater than 45%.

3. Congenital Heart Disease

RBBB is often associated with an atrial septal defect, ventricular septal defect, Ebstein's anomaly, and tetralogy

of Fallot. A common treatment for RBBB in children is open heart surgery to correct tetralogy of Fallot or ventricular septal defect.

4. Valvular and Hypertensive Heart Disease

Valvular lesions that cause right ventricular hypertrophy may cause RBBB. Other causes include:

1. Coarctation of the aorta
2. Pericarditis
3. Myocarditis
4. Chagas disease
5. Pulmonary embolism
6. Cor pulmonale
7. Cardiomyopathy
8. Brugada syndrome

C. Right Bundle Branch Block and the Left Anterior Hemiblock

RBBB may be associated with a block of the anterior branch of the left bundle. This branch or fascicle is thin and long and has a single blood supply. It is commonly damaged by ischemic chronic coronary artery disease or during acute myocardial infarction as outlined above. Fibrosis, Chagas disease, and other pathologic processes may cause damage to this thin fascicle resulting in a minor block. This minor block was first described by Rosenbaum as a left anterior hemiblock, but now it is called left anterior fascicular block.

The diagnosis of the left anterior fascicular block is made when there is left axis deviation, a small Q wave in lead I, and small R wave in lead III (see Fig. 3). When patients develop RBBB and left anterior hemiblock during acute myocardial infarction some patients require the insertion of a pacemaker to prevent complete heart block. When RBBB and left anterior hemiblock are observed in patients who have never had a heart attack and have structurally normal hearts as determined by echocardiography, ECG, and other methods, the prognosis is good.

D. Incomplete Right Bundle Branch Block

In incomplete RBBB, the QRS duration is 90–115 ms, causing other symptoms similar to complete RBBB. It is commonly associated with atrial septal defect. Incomplete RBBB is a common ECG finding in normal individuals. Straight back syndrome, pectus excavatum, coarctation of the aorta, right ventricular volume overload, and muscular dystrophy may also be associated with incomplete RBBB.

II. LEFT BUNDLE BRANCH BLOCK

Left bundle branch block (LBBB) is common after age 60 and is due to a block of the conduction in the bundle that receives impulses from the atrium and conducts the electrical current through the left ventricle (Fig. 1). The ECG is typical, and the physician makes the diagnosis only after looking at the ECG.

A. ECG Diagnostic Criteria

In LBBB the QRS complex is wide and bizarre looking with a duration of greater than 120 ms (see Fig. 4). Other criteria include notched R wave in lead I, aVL, V5, or V6; leads V1 and V2 have small or no R waves; and the ST segment in V1 and V2 is elevated.

B. Causes of Left Bundle Branch Block

RBBB is often seen in normal individuals. LBBB, on the other hand, is more often due to subtle diseases of the heart, including coronary artery disease, valvular heart disease, muscle scars, cardiomyopathies, fibrosis, degenerative disease (Lev and Lenegre disease), and all causes of left ventricular hypertrophy. Approximately 15% of patients with aortic stenosis that causes severe left ventricular hypertrophy exhibit LBBB.

Although LBBB is a serious conduction disturbance, the electrical current gets to the left ventricular myocardium via the right ventricular conduction system. This activates the left ventricle with a time delay that is observed as an increased duration of the QRS complex of the ECG. It does not cause disturbance of the heart rate and virtually never requires an artificial pacemaker.

C. Prognosis

In patients younger than age 50 with LBBB and structurally normal hearts there is no adverse prognostic significance; these individuals have idiopathic LBBB or early development of degenerative disease of the conduction system. New LBBB appearing after age 50 requires investigation. In the Framingham study 55 individuals developed new LBBB at about 62 years with cardiovascular disease manifested in 89%, and 50% died within 10 years. A marker of favorable prognosis is the ECG and echocardiographic absence of left atrial enlargement, which if present indicates severe left ventricular hypertrophy and significant disease. In patients with coronary artery disease, heart failure, hypertension, valvular heart disease, and cardiomyopathy the prognosis depends on the severity of the heart disease. In patients with underlying heart disease, greater than 25% are expected to die within 2 years and greater than 50% die suddenly. The prognosis is poor in individuals with LBBB who develop myocardial infarction or those in whom acute infarction causes LBBB. In these cases thrombolytic therapy or percutaneous coronary intervention is necessary.

BIBLIOGRAPHY

- Hiss, R. G., and Lamb, L. E. Electrocardiographic findings in 122,043 individuals. *Circulation*, 25:947, 1962.
- Khan, M. Gabriel *Rapid ECG Interpretation*, second edition, W. B. Saunders, Philadelphia, 2003.
- Schneider, J. P., Thomas, H. E., Kreger, B. E. et al. Newly acquired left bundle branch block, the Framingham study. *Ann. Int. Med.*, 90:303, 1979.
- Surawicz, B., and Nilans, T. K. *Chou's Electrocardiography in Clinical Practice*, W. B. Saunders, Philadelphia, 2001.

Caffeine and the Heart

- I. Biochemistry
- II. Effects

GLOSSARY

- arrhythmia** general term for irregularity or rapidity of the heartbeat, an abnormal heart rhythm.
- cardiac output** the volume of blood pumped by the ventricle per unit time expressed in liters per minute; it is a function of the stroke volume multiplied by the heart rate.
- heart failure** failure of the heart to pump sufficient blood from the chambers into the aorta; inadequate supply of blood reaches organs and tissues.

CAFFEINE IS A PSYCHOACTIVE DRUG THAT OCCURS naturally in many foods and beverages including coffee, tea, chocolate, and cocoa. It has found its way into many commercial soft drinks because of its proven mild stimulant effect and relative safety when consumed in small amounts. But caffeine can produce beneficial effects in one individual and potentially harmful effects in another. Many pain relievers contain caffeine added to aspirin or acetaminophen to potentiate the effects of these agents. Levels of caffeine in common beverages and foods are shown in Table 1 and levels of caffeine in common drugs are listed in Table 2.

Caffeine is the most widely used psychoactive substance. More than 100 billion doses of caffeine are consumed annually in North America. Caffeine occurs naturally in more than 60 plant species worldwide, and the drinking of tea in China dates back to around 2500 BC.

I. BIOCHEMISTRY

Caffeine is a xanthine derivative — 1, 3, 7-trimethyl-xanthine. Other naturally occurring xanthines include the well-known theophylline (the major constituent in tea) and theobromine. Coffee is a major source of caffeine and

TABLE I
Levels of Caffeine in Common Beverages and Foods

Beverage/food	Serving size (oz)	Approximate mg caffeine/serving
Coffee		
Drip	5	150
Percolated	5	110
Instant, regular	5	50–100
Instant, flavored mix	5	25–75
Decaffeinated coffee	5	1–6
Black tea		
1-min brew	5	10–20
3-min brew	5	20–35
5-min brew	5	25–35
Instant tea	5	30–60
Cocoa beverage	5	2–20
Soft drinks		
Jolt	12	70
Caffeinated cola drinks	12	30–65
Mountain Dew, Mello Yello, Sunkist Orange	12	40–50
7-Up, Sprite, RC-100, Fanta Orange, Hires Root Beer	12	0
Chocolate		
Cake	1/16 of 9-inch cake	14
Ice cream	2/3 cup	5
Mr. Goodbar	1.65	6
Special dark, Hershey	1.02	23

From Blount, J.P., and Cox, W.M. (1997), Caffeine, Encyclopedia of Human Biology, Vol. 2, 2nd Ed., San Diego: Academic Press, p. 275.

chlorogenic acid and also contains a substantial amount of magnesium and other micronutrients. Caffeine is a powerful central nervous stimulant and moderate doses of 200 mg contained in two cups of coffee activate the cerebral cortex sufficiently to slow changes in an individual's electroencephalogram (EEG). Caffeine is also a mild cardiac stimulant.

TABLE II
Levels of Caffeine in Common Drugs

Drug	Standard adult dose	Approximate mg caffeine/standard dose
Prescription painkillers		
Darvon compound capsule	1	32
Cafergot tablet (migraine)	1	100
Nonprescription (over-the-counter) painkillers		
Anacin, Midol, Vanquish	2	65
Plain aspirin	2	0
Cold/allergy medicine		
Dristan	2	30
Coryban-D, Sinarest, Triaminicin	1	30
Stimulants		
No-Doz	2	200
Vivarin	1	200

From Blount, J.P., and Cox, W.M. (1997), *Caffeine*, Encyclopedia of Human Biology, Vol. 2, 2nd Ed., San Diego: Academic Press, p. 275.

II. EFFECTS

A. Cardiovascular

Caffeine has mild and variable effects on the heart rate, the heart muscle, blood pressure, blood flow, and blood cholesterol.

I. Heart Rate

Caffeine generally increases the heart rate. After ingestion of caffeine a mild decrease in heart rate may be observed within the first hour followed by an increase in heart rate during the following two hours. Chronic caffeine use elevates the resting heart rate and significant reductions in heart rate are observed upon cessation of caffeine intake. Caffeine also stimulates the medullary vagal nerve nuclei and thus causes a mild decrease in heart rate depending on the dose and time of ingestion.

A genuine tachycardia, heart rate greater than 100 beats per minute, is not often observed. Arrhythmias that cause a sensation of palpitations may be precipitated, however, by two or three cups of coffee daily in susceptible individuals. Patients with paroxysmal atrial tachycardia, (AV nodal reentrant tachycardia) and those with atrial or ventricular premature beats may note an increase in the frequency of these beats and pronounced increase in heart rates may be precipitated. In these individuals cessation of caffeine

intake is often beneficial. However, the most common arrhythmia encountered in medical practice, atrial fibrillation, is not adversely affected by caffeine intake (see the chapter Arrhythmias/Palpitations).

2. Heart Muscle

Caffeine has a direct stimulant effect on the heart muscle and causes an increase in the force of myocardial contraction (i.e., an inotropic effect). The inotropic effects are, however, minimal compared to that of digoxin, the mild inotropic agent commonly used to treat heart failure. Because of the increase in the force of myocardial contractility and increase in the heart rate, the cardiac output increases slightly. This effect is important in patients with heart failure in whom two cups of coffee daily may induce a minimal benefit without harm.

3. Blood Pressure

Effects of caffeine on blood pressure are controversial. Single doses can cause a small increase in blood pressure in users; the increase in blood pressure appears to be somewhat greater in nonusers who occasionally consume coffee. One or two cups of coffee can increase blood pressure slightly in habitual users, they have no effect on chronic coffee drinkers. Significant reduction in blood pressure has been observed in chronic users who abstain, but the methodology in several studies on hypertension and caffeine use has been questioned. It is not known whether caffeine interacts unfavorably with antihypertensive medications.

4. Heart Attacks

The link between caffeine consumption and heart attacks remains controversial. The studies done in 1980 failed to implicate coffee consumption, but two studies since 1985 have shown an apparent link between heavy coffee use and heart attacks. Carefully organized studies with sound methodology are required to clarify this important issue.

5. Blood Flow and Blood Vessels

Caffeine dilates systemic blood vessels, small arteries, and arterioles, but it constricts extracranial vessels that are believed to aid in the relief of migraine headaches. Cafergot, a drug used for migraines, contains 100 mg of caffeine and 1 mg of ergotamine.

6. Cholesterol

Chronic caffeine intake appears partially responsible for increased blood cholesterol levels. Although this effect is controversial, discontinuing coffee moderately reduces total blood cholesterol levels less than 7%.

B. Diabetes, Coffee, and the Heart

Most diabetics succumb to a fatal or nonfatal heart attack, or heart failure (see the chapter Diabetes and Cardiovascular Disease). A recent study in The Netherlands has shown that heavy coffee consumption was associated with a substantially lower risk of clinical type 2 diabetes. It is unfortunate that such a large intake of caffeine is required to produce such a beneficial effect.

The phenol chlorogenic acid reduces glucose absorption and oxidative stress *in vitro* and inhibits hydrolysis of glucose-6-phosphate, which could reduce glucose output in the liver. Coffee contains substantial amounts of magnesium that could improve insulin sensitivity and insulin secretion and has been associated with a lower risk of type 2 diabetes. The epidemic of diabetes worldwide continues and any strategy that can be added to the armamentarium to prevent diabetes would be welcome.

I. Clinical Study: van Dam et al.

van Dam investigated the association between coffee consumption and risk of clinical type 2 diabetes in 17,111 Dutch men and women aged 50–60. During 125,774 person-years of follow up, 306 new cases of type 2 diabetes were reported.

After adjustment for potential confounders, individuals who drank at least 7 cups of coffee daily were 0.05 times as likely as those who drank 2 cups of coffee daily to develop type 2 diabetes ($p = 0.0002$). Higher coffee consumption was associated with a lower risk of type 2 diabetes.

It is known that caffeine acutely lowers insulin sensitivity. In a small intervention study, increased coffee consumption for two weeks reduced fasting blood glucose, whereas the substitution of decaffeinated coffee for caffeinated coffee for 3 weeks did not affect blood glucose.

BIBLIOGRAPHY

- Blount, J. P., and Cox, W. M. Caffeine. *Encyclopedia of Human Biology*, Vol. 2, second edition, Academic Press, San Diego, 1997, p. 275.
- Keijzers, G. B., De Galan, B. E., Tack, C. J. et al. Caffeine can decrease insulin sensitivity in humans. *Diabetes Care*, 25:364–69, 2002.
- Pincomb, G. A. Acute blood pressure elevations with caffeine in men with borderline hypertension. *Am. J. Cardiol.*, 77:270–74, 1996.
- van Dam, R. M., and Feskens, E. J. M. Coffee consumption and risk of type 2 diabetes mellitus. *Lancet*, 360:1477–78, 2002.

Calcium Antagonists

- I. Mechanism of Action
- II. Available Calcium Antagonists
- III. Therapeutic Benefits
- IV. Next Generation Agents

GLOSSARY

angina pectoris short duration, recurrent chest pain or pressure often accompanied by feelings of suffocation and impending doom; most frequently associated with lack of blood and oxygen to the heart muscle.

arrhythmia general term for an irregularity or rapidity of the heartbeat, an abnormal heart rhythm.

ejection fraction the fraction of blood ejected from the heart into the arteries, normally this ranges from 60 to 75%; a low ejection fraction is less than 40%; often used as a marker of left ventricular contractility.

heart failure failure of the heart to pump sufficient blood from the chambers into the aorta; an inadequate supply of blood reaches organs and tissues.

inotropic an effect that affects the force of muscular contractions; negative inotropic refers to decreased myocardial contractility that may lead to poor pumping of blood, reduced ejection fraction, and heart failure.

myocardial infarction death of an area of heart muscle due to blockage of a coronary artery by blood clot and atheroma; medical term for heart attack or coronary thrombosis.

myocytes single muscle cells.

pulmonary edema fluid in the air sacs and alveoli; the lungs become congested and severe shortness of breath occurs.

I. MECHANISM OF ACTION

Calcium movement into cells is mediated by several mechanisms. Albrecht Fleckenstein showed that the calcium channels can be selectively blocked by a class of agents. He called these agents calcium antagonists.

Calcium movement into the cells is mediated by several mechanisms. Calcium antagonists act at the plasma membrane to inhibit calcium entry into cells by blocking voltage-dependent calcium channels.

Calcium ions play an important role in the contraction of cardiac, skeletal, and smooth muscle. Myoplasmic calcium depends on calcium entry into the cell. Calcium binds to the regulatory protein troponin, removing the inhibitory action of tropomyosin. In the presence of adenosine triphosphate this allows the interaction between myosin and actin with consequent contraction of the muscle cell.

There are at least three different types of calcium channels designated as L, T, and N types. The L-type channels, once activated, remain for a long period of time and have a large calcium-carrying capacity. The T channels have a brief opening time and N channels have characteristics that are neither of the L nor T type. Only the L-type channels are sensitive to the action of calcium antagonists. The effect of the calcium antagonists is to restrict calcium entry, and over a given period of time fewer calcium ions are available for participation in intracellular events such as muscle contraction and neuronal activity. Thus some have labeled these compounds calcium channel blockers, calcium channel antagonists, calcium entry blockers, and slow calcium blockers.

Calcium antagonists differ from one another in terms of their potency, tissue selectivity, and duration of action. The calcium antagonists available for clinical use are mainly L-type channel blockers. The T channel appears at more negative potentials and seems to play a role in the initial depolarization of the sinus node and atrioventricular (AV) node tissue. Mibefradil, a T channel blocker, caused bradycardia and a host of adverse effects that caused the drug's premature withdrawal from the market.

The three major calcium antagonists include nifedipine, diltiazem, and verapamil (see Fig. 1 for their structural formulas). Dihydropyridine, the prototype of which is nifedipine, appears to act by plugging the calcium

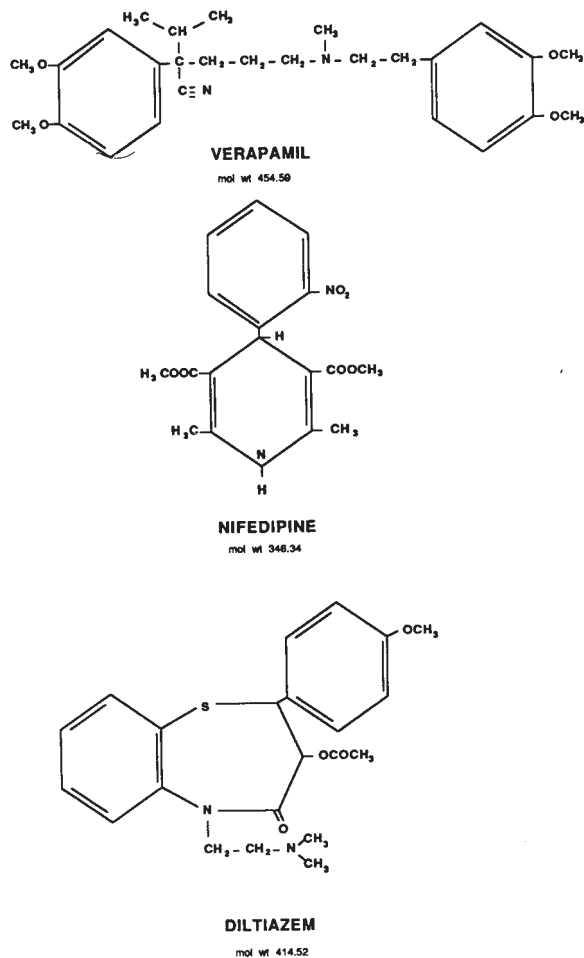

FIGURE 1 Structural formulas of the three calcium antagonist prototypes: verapamil (a phenylalkylamine), nifedipine (a dihydropyridine), and diltiazem (a benzothiazepine). (From Nayler, W.G. (1997). Calcium antagonists, *Encyclopedia of Human Biology*, Vol. 2, 2nd Ed., San Diego, Academic Press, p. 295.)

channels. These agents cause dilation of coronary arteries and marked peripheral arteriolar dilatation resulting in a profound fall in blood pressure. There is little or no action on the sinoatrial (SA) node and conducting tissue.

Verapamil and diltiazem are phenylalkylamines and benzothiazepines. They cause distortion of calcium channels and coronary artery dilation, but there are additional effects on the SA and AV nodes. These agents also have a negative inotropic effect and decrease myocardial contractility. Thus, the dihydropyridines, phenylalkylamines, and benzodiazepines have vastly different actions. For example, only amlodipine and felodipine, of the dihydropyridine family, have proved relatively safe in patients with left ventricular dysfunction and heart failure. Other agents may precipitate heart failure. The hemodynamic and

TABLE I
Hemodynamic and Electrophysiologic Effects of Calcium Antagonists

	Nifedipine ^a	Diltiazem	Verapamil
Coronary dilation	++	++	+
Peripheral dilation	++++	++	+++
Negative inotropic	+	++	+++
AV conduction↓	↔	+++	++++
Heart rate	↑↔	↓↔	↓↔
Blood pressure↓	++++	++	+++
Sinus node depression	↔	++	++
Cardiac output↑	++	↔	↔

^aOr other dihydropyridines.

+ = minimal effect; ++++ = maximal effect; ↔ = no significant change; ↓ = decrease; ↑ = increase.

From, Khan, M. G. (2003). *Cardiac Therapy*, 6 Ed., Philadelphia: W. B. Saunders, p. 3.

electrophysiologic effects of calcium antagonists are given in Table 1.

II. AVAILABLE CALCIUM ANTAGONISTS

A. Dihydropyridines

These agents cause dilation of arteries throughout the body including mild dilatation of coronary arteries. They also cause a variable decrease in myocardial contractility that may lead to heart failure in susceptible individuals.

Dihydropyridines include amlodipine, felodipine, and nifedipine. They are indicated for the management of hypertension. They may also be used for the treatment of stable angina, but only in combination with a beta-blocking drug that prevents an increase in heart rate and the increase in cardiac workload that may be caused by dihydropyridines. The common adverse effects include edema of the ankles, flushing, headaches, and rarely, hypertrophy of the gums. Other dihydropyridines include isradipine, nicardipine, nimodipine, nitrendipine, and niludipine.

I. Amlodipine (Norvasc)

This dihydropyridine has a long half-life of 35–50 h and peak blood levels are reached after 6–12 h. Amlodipine is an effective antihypertensive agent that is used worldwide. It has a good safety profile but pulmonary edema (heart failure) may be precipitated in patients with severe left ventricular dysfunction and ejection fraction of less than

30%. Edema of the ankles, feet, and lower leg may be bothersome in about 10% of treated patients. This drug is often combined with a beta-blocker in the management of angina. The dose for angina or hypertension is 5–10 mg once daily.

2. Felodipine (Plendil)

This dihydropyridine has actions, effects, and indications that are similar to amlodipine. The dose for hypertension is 2.5–5 mg daily with a maximum dose of 10 mg.

3. Nifedipine (Procardia, Adalat XL)

Nifedipine is the first calcium antagonist used in clinical practice. It was introduced during the early 1980s for the management of hypertension, angina, and particularly coronary artery spasm (variant angina) and is still used worldwide. The drug is an excellent antihypertensive agent. Headache, edema of the ankles, and facial flushing occur in about 15% of patients. Although introduced for the management of angina, like other dihydropyridines, the drug should be used only for stable angina in patients who are also administered a beta-blocker. For the management of coronary artery spasm (Prinzmetal variant angina), the drug can be used without beta-blockers, which are contraindicated in this condition.

Short-acting capsule or tablet formulations of nifedipine are no longer recommended because an increase in morbidity and mortality has been reported in patients with coronary artery disease. The slow-release once daily formulation is now used worldwide at a dose of 30–60 mg once daily. The maximum dose of 90 mg should be used with caution.

B. Benzothiazepines

I. Diltiazem

Diltiazem is a mild arteriolar vasodilator. It is a widely used calcium antagonist because its safety profile is good. The blood pressure lowering effect of this benzothiazepine is not as powerful as the dihydropyridines, and a large dose is usually required to obtain a satisfactory antihypertensive effect. Diltiazem has a milder action than the dihydropyridines and causes less vasodilatation of arteries; thus it is a weak antihypertensive agent. The drug causes some decrease in myocardial contractility and heart failure may be precipitated in patients with left ventricular dysfunction or in patients who are administered a beta-blocking drug concomitantly.

Most important, the drug inhibits electrical conduction through the AV node. It is useful for the management of supraventricular tachycardias by slowing rapid heart rates that may occur with atrial fibrillation.

Unfortunately, this drug causes some suppression of the sinus node and normal pacemaker activity and may cause bradycardia. It should be avoided in patients with sick sinus syndrome and heart failure. Adverse effects include increased liver function tests, increased transaminases, and constipation, but headache and edema of the ankles are less common than with the dihydropyridines.

Important interactions occur with digoxin, and digoxin levels may be increased by about 33%. Diltiazem combined with amiodarone may produce deleterious effects on the sinus pacemaker causing arrest and hypotension. Interactions have been noted with cyclosporine, cimetidine, and carbamazepine.

The short-acting tablet formulation of diltiazem is not recommended. Long-acting and slow-release formulations are administered 180 mg to a maximum of 300 mg once daily.

C. Phenylalkylamines

I. Verapamil

Verapamil is a moderately potent vasodilator. Two major differences between the actions of verapamil and the dihydropyridines include a major depressant effect on the AV node and a mild depressant effect on the SA node. Also, depression of myocardial contractility for verapamil is considerably more than the maximum effect observed for dihydropyridines. This marked negative inotropic effect may precipitate heart failure in patients with left ventricular dysfunction and an ejection fraction less than 40%. Because of this effect, verapamil should not be combined with a beta-blocking agent.

The electrophysiologic effect of mild depression of conduction through the AV node makes the drug effective in the management of supraventricular tachycardia. Given intravenously, verapamil was used worldwide for the management of this condition from 1984 to 1996 and has now been relegated to second choice behind adenosine.

Verapamil is indicated for the management of hypertension and for angina, particularly when beta-blockers are contraindicated. It is also used for the management of coronary artery spasm. The intravenous preparation is indicated for supraventricular tachycardia. Doses of 120–240 mg sustained-release, long-acting preparations are advised once daily.

Verapamil is contraindicated in patients with bradycardia (a heart rate of <60) and those with disease of the

sinus and AV nodes. This drug may precipitate heart failure and is contraindicated in patients with left ventricular dysfunction or an ejection fraction less than 40%. It is also contraindicated in patients with acute myocardial infarction.

Adverse effects include severe constipation that may be particularly bothersome in the elderly. Interactions occur when combined with beta-blockers and may cause severe bradycardia, heart block, or heart failure. Caution is necessary because interactions have been noted with amiodarone, oral anticoagulants, guanidine, and tranquilizers. Other phenylalkylamines include anipamil, ronipamil, devapamil, fendiline, and tiapamil.

III. THERAPEUTIC BENEFITS

Calcium antagonists are indicated for the conditions outlined below.

- Isolated hypertension without organ damage or coexisting disease benefits from calcium antagonists.
- These agents are particularly useful for isolated hypertension in older people of African origin and usually achieve the blood pressure goal; they have been shown in randomized clinical trials to be more effective than ACE inhibitors, beta-blockers, and diuretics.
- In younger people of African origin a clinical study showed that diltiazem was effective in 64% compared with 47% for atenolol and 40% for diuretics.
- Patients with severe stage II and III hypertension require the combination of several antihypertensive agents and calcium antagonists are appropriate except in patients with left ventricular dysfunction.
- Calcium antagonists are a critical part of combination therapy in hypertensive patients with a variety of underlying disorders (comorbidities) in whom blood pressure control at more aggressive goals has been deemed essential but remains elusive.
- Calcium antagonists are used to treat hypertension associated with renal disease or renal failure if ACE inhibitors are contraindicated or poorly effective.
- Calcium antagonists have shown benefits in hypertensive diabetic patients; the large SYST-EUR and the Systolic Hypertension in China (SYST-China) trials demonstrated more than a 50% reduction in total mortality in the diabetic subgroup.
- In patients with stable angina the addition of a calcium antagonist, particularly a dihydropyridine or diltiazem, has been shown in clinical trials to cause significant amelioration of recurrent chest pain.
- In patients with severe aortic regurgitation, the unloading effect of nifedipine has been shown in a clinical trial to cause significant reversal of the left ventricular dilatation and hypertrophy, and surgical therapy may be appropriately delayed from 1 to 2 years.
- Patients with cold fingers and Raynaud's phenomenon may find some benefit with calcium antagonists.
- The dihydropyridine nimodipine, in a clinical trial, was shown to be useful in the management of cerebral arterial spasm caused by subarachnoid hemorrhage with controlled blood pressure.
- Following coronary artery bypass graft using the radial artery as a conduit, dihydropyridine calcium antagonists are used for an indefinite period to prevent spasm and occlusion of the arterial graft.

IV. NEXT GENERATION AGENTS

Several dihydropyridine calcium antagonists have been introduced during the past 25 years. First generation dihydropyridines are the naturally short-acting agents that include felodipine, isradipine, nifedipine, and nitrendipine. These rapid-acting vasodilators are powerful antihypertensive agents, but their fast onset of action results in marked vasodilation that causes reflex stimulation of the sympathetic nervous system and hemodynamic adverse effects that include increased heart rate, increased cardiac workload, and an increased incidence of heart failure in patients with left ventricular dysfunction. These adverse effects have become controversial and the short-acting formulations of dihydropyridines such as verapamil and diltiazem are no longer recommended. They have largely been removed from the marketplace.

Second generation agents such as verapamil SR, nifedipine XL, felodipine ER, and diltiazem SR and CD were developed with modified release properties to slow their onset of action. Adverse effects are still high, particularly edema and constipation, and heart failure is precipitated, albeit rarely.

Third generation agents include amlodipine. These agents have a naturally occurring long plasma half-life (over 24 h) but are washed out from the receptor relatively fast. Equilibrium is essentially between the plasma protein-bound drug and the calcium L channel. Amlodipine moves quickly onto the calcium channel to provide a quick onset of action and thus vasodilatation, which results in modest sympathetic stimulation and unwanted mild tachycardia or an increase in heart rate of about 10 beats per minute

from baseline. These agents may precipitate pulmonary edema in patients with left ventricular dysfunction.

Next generation agents include lercanidipine, lacidipine, and manidipine. These dihydropyridines have important and subtle differences when compared with second and third generation dihydropyridine calcium antagonists. Lercanidipine has been shown to have major advantages over amlodipine. Because the drug dilates both afferent and efferent arterioles, the high incidence of peripheral edema caused by older calcium antagonists is reduced more than 50%. The balanced effect of lercanidipine and manidipine on efferent and afferent arterioles is important in renal protection. The older calcium antagonists listed above dilate only afferent arterioles. The COHORT study of elderly hypertensive patients concluded that lercanidipine and lacidipine are much better tolerated than amlodipine.

Recent investigations indicate that lercanidipine administered to hypertensive diabetic patients is more effective than the angiotensin receptor blocker, losartan, in reducing left ventricular hypertrophy and left ventricular mass.

These third generation dihydropyridines represent an important addition to the therapeutic armamentarium.

Their place in clinical practice will increase further if they are shown to be devoid of the major adverse effect of all calcium antagonists — the precipitation of heart failure in patients with significant left ventricular dysfunction.

BIBLIOGRAPHY

- Khan, M. Gabriel. In *Cardiac Drug Therapy*, sixth edition, W. B. Saunders, Philadelphia, 2003, p. 81–101.
- Khan, M. G. In *Heart Disease Diagnosis and Therapy: Cardiogenic Shock*, second edition. Humana Press, New Jersey, 2005.
- Messerli, F. H. Evolution of calcium antagonists: Past, present, and future. *Clin. Cardiol.* 26 (Suppl. 11), 12–16, 2003.
- Tuomilehto, J., Rastenyte, D., Birkenhager, W. H. et al. Effects of calcium channel blockade in older patients with diabetes and systolic hypertension. Systolic hypertension in Europe Trial Investigators. *N. Engl. J. Med.*, 34:677–84, 1999.
- Wang, J. G., Staessen, J. A., Gong, L. et al. Chinese trial on isolated systolic hypertension in the elderly. Systolic hypertension in China (Syst-China) Collaborative group. *Arch. Intern. Med.*, 160:211–20, 2000.
- Zanchetti, A. Emerging data on calcium channel blockers: The COHORT study. *Clin. Cardiol.*, 26: (Suppl. 11), 17–20, 2003.

Carcinoid Heart Disease

- I. Heart Damage
- II. Diagnosis
- III. Treatment
- IV. Clinical Study

GLOSSARY

endocardium internal lining of the heart.

malignant tumor the tumor that invades and spreads to adjacent and distant organs.

tricuspid regurgitation tricuspid valve leaks and blood is propelled backwards from the right ventricle into the right atrium and into the neck veins.

CARCINOID HEART DISEASE MAY OCCUR IN patients with carcinoid syndrome. The main symptoms of flushing, diarrhea, and occasional wheezing are caused mainly by 5-hydroxytryptamine or serotonin, that is liberated from carcinoid tumors that originate from chromaffin cells (neuroendocrine cells) of the terminal ileum. These tumors of the small intestine contain neurosecretory granules that release a variety of biogenic amines that include serotonin, histamine, bradykinins, tachykinins, and prostaglandins. Involvement of the heart occurs in about half of carcinoid syndrome cases. It is seen mainly in patients with malignant tumors that have metastasized to the liver.

I. HEART DAMAGE

Bioactivity amines, principally, serotonin, liberated from a malignant tumor causes deformation of the tricuspid valve that leads to tricuspid regurgitation. The pulmonary valve becomes deformed by the plaque-like material resulting in a leaky, incompetent valve (pulmonary regurgitation) or a tight, stenotic valve (pulmonary stenosis). In a clinical study of carcinoid heart disease, 97% of patients had

right-sided valvular involvement; severe tricuspid valve regurgitation occurred in all patients and severe pulmonary valve regurgitation in 72%.

A whitish colored plaque forms mainly on the right side of the heart and only in less than 3% of cases are the mitral and aortic valves of the left heart affected. The lesions of the valves and endocardium are caused by serotonin that reaches a high concentration in the right heart. Minimal quantities reach the left side of the heart because 5-hydroxytryptamine is destroyed in the lungs by monoamine oxidase. Some serotonin is destroyed in the liver and in the brain.

The anorectic drugs fenfluramine and dexfenfluramine exert their effects through interference in serotonin metabolism. It is interesting that they were associated with lesions identical to that seen in carcinoid syndrome.

II. DIAGNOSIS

Carcinoid tumors are rare. They arise from enterochromaffin cells typically located in the gastrointestinal tract. At the time of diagnosis, more than 30% of patients have disseminated disease characterized by cutaneous vasomotor flushing, secretory diarrhea, and mild bronchospasm.

In carcinoid heart disease, 5-hydroxytryptamine is metabolized to 5-hydroxyindoleacetic acid (5-HIAA). Elevated levels of 5-HIAA in the urine confirm the diagnosis. Echocardiography confirms thickening of the tricuspid and pulmonary valves with tricuspid and pulmonary valve regurgitation and in some cases, pulmonary valve stenosis. The lesions in the heart may cause right-sided heart failure. Because the blood cannot be ejected adequately through the pulmonary valve, the right ventricle work is increased. Because the tricuspid valve leaks, blood regurgitates into the veins of the neck and back toward the liver, which becomes pulsatile with each heartbeat.

The malignant tumor may spread to involve the muscle of the heart. These metastatic carcinoid tumors of the heart are about 2 cm and can be detected by echocardiography.

III. TREATMENT

There are no specific treatments for carcinoid heart disease. The noncardiac symptoms may be controlled with somatostatin, but the action of this drug is only minutes. Octreotide has been shown to be much more effective in reducing flushing diarrhea and urinary levels of 5-HIAA.

IV. CLINICAL STUDY

Moller et al. studied the poorly understood factors associated with the progression of carcinoid heart disease. They studied 71 patients who underwent serial echocardiographic studies performed more than one year apart and 32 patients referred directly for surgical intervention. These workers concluded that high serotonin levels are related to the progression of carcinoid heart disease, and the risk of progressive heart disease is higher in patients who receive chemotherapy.

Somatostatin is a potent inhibitor of many processes including serotonin. In this nonrandomized study it

appears that somatostatin was ineffective in preventing development of carcinoid heart disease. Findings suggested that although serotonin is related to development of carcinoid disease, neither somatostatin therapy nor hepatic dearterialization prevents the progression of chronic lesions. Patients in the study who received cytotoxic chemotherapy had the highest risk of progressive carcinoid heart disease. The exact mechanism involved in the progression of carcinoid disease requires further clarification.

BIBLIOGRAPHY

- Howard, R. J., Drobnac, M., Rider, W. D. et al. Carcinoid heart disease: Diagnosis by two-dimensional echocardiography. *Circulation*, 66:1059-65, 1995.
- Moller, J. E., Connolly, H. N., Rubin, J. et al. Factors associated with progression of carcinoid heart disease. *N. Engl. J. Med.*, 348:1005-15, 2003.
- Pandya, U. H., Pellikka, P. A., Enriquez-Sarano, M. et al. Metastatic carcinoid tumor to the heart: Echocardiographic — pathologic study of 11 patients. *J. Am. Coll. Cardiol.*, 40:1328-32, 2002.

Cardiogenic Shock

- I. Causes
- II. Pathophysiology
- III. Management
- IV. Perspective and Research Implications

GLOSSARY

atheromatous same as atherosclerotic, a plaque that juts into the lumen and obstructs the flow of blood in arteries.

myocardial infarction death of an area of heart muscle due to blockage of a coronary artery by blood clot and atheroma; medical term for a heart attack of coronary thrombosis.

revascularization procedures that include coronary artery bypass surgery to bypass obstructive atheromatous plaques or percutaneous coronary intervention (PCI) using balloon angioplasty with or without stents.

tissues aggregation of similarly specialized cells which together perform certain special functions.

CARDIOGENIC SHOCK IS CAUSED BY A DECREASED pumping ability of the heart that results in a shock-like state with insufficient blood perfusion to organs and tissues. During cardiogenic shock, systolic blood pressure is less than 90 mmHg for greater than one hour and not responsive to IV fluids. The cardiac index is less than 2.2 L/minute/m², and the pulmonary capillary wedge pressure is greater than 18 mmHg. Patients usually have clouded consciousness and cold extremities.

I. CAUSES

Acute myocardial infarction is the most common cause of cardiogenic shock. Other causes of cardiogenic shock are given in Table 1. The complete occlusion of a coronary artery by a clot causes death of an area of heart muscle that is supplied by that blood vessel and its branches. If a very large area of heart muscle is involved, the general pumping capability of the heart is severely compromised. Because

dead myocardium cannot contract, blood cannot be effectively ejected out of the left ventricle into the aorta [see Fig. 1 in the chapter Anatomy of the Heart and Circulation). Blood is held up in the lungs and fluid accumulates in air sacs causing pulmonary edema which results in severe shortness of breath. Because blood cannot be ejected from the heart, the blood pressure falls drastically. When more than 40% of the heart muscle is involved, cardiogenic shock often occurs.

II. PATHOPHYSIOLOGY

In general terms shock is a clinical state in which target organ–tissue perfusion is inadequate to supply vital substrates and remove the metabolic waste. Inadequate cellular oxygenation leads to marked generalized impairment of cellular function and multiorgan failure.

The heart tries to contract more vigorously in the face of this catastrophic event; the renin–angiotensin–aldosterone system is activated and causes severe vasoconstriction in an attempt to increase blood pressure (see Fig. 1 in the chapter Angiotensin-Converting Enzyme Inhibitors/Angiotensin Receptor Blockers), but over time the hypercontractility of the heart ceases. This occurs because there is utilization of glucose over fatty acids, loss of Krebs cycle intermediates, and depletion of substrate required for ATP production.

Figure 1 illustrates the pathophysiology of shock. Because forward flow of blood is severely retarded, blood returned to the heart from veins of the body and from the lungs cannot be accommodated in a heart that is already full of blood. Blood then backs up into the venous circulation of the neck and in the lungs. This pressure of blood returning to the heart is referred to as an increased filling pressure (Fig. 1). It is easy to visualize that the shock state may occur if there is no filling pressure as would occur in severe dehydration or severe blood loss (i.e., the tank has no gas).

Basically cardiogenic shock results from profound reduction in cardiac output. This is usually caused by

marked reduction of left or right ventricular systolic function, despite adequate ventricular filling pressures, and there is a failure of compensatory vasoconstrictive mechanisms that are overwhelmed by inappropriate vasodilation in large, nonvital vascular beds. Thus this deprives critical areas like the heart, brain, and kidney of perfusion. Hochman points out that data from the shock trial and registry indicate that cardiogenic shock is often not simply due to extensive myocardial infarction with pump failure, "but also involves inflammatory mediators. These mediators induce nitric oxide synthase (iNOS) expression, increasing nitric oxide (NO) and peroxynitrite levels, resulting which results in further myocardial dysfunction and failure of an appropriate peripheral circulatory response."

III. MANAGEMENT

Most patients require an intra-aortic balloon pump and IV vasopressor drugs to support blood perfusion to organs and tissues. The opening of the obstructed artery using balloon angioplasty with the insertion of stents has improved survival. Because approximately 40% of cardiogenic shock patients have occlusions in three coronary arteries, emergency coronary artery bypass surgery is the only measure that has improved survival in this group. In the SHOCK trial, the overall 30-day mortality rate was 47% in patients undergoing emergency revascularization versus 56% in the medical stabilization group.

This improvement was maintained at the six-month follow up.

IV. PERSPECTIVE AND RESEARCH IMPLICATIONS

The incidence of cardiogenic shock will not decrease until the main cause, which is obstruction to coronary arteries by atheromatous plaque and thrombosis, is arrested. Thrombolytic therapy is of little value and revascularization with balloon angioplasty and coronary bypass surgery can only be undertaken in special centers. The SHOCK trial only studied 300 patients. More research is required to assess if we could develop cardioactive agents to protect the myocardium from necrosis during an occlusion of a coronary artery.

BIBLIOGRAPHY

- Hasdal, D., Topol, E. J., Calif, R. M. et al. Cardiogenic shock complicating acute coronary syndromes. *Lancet*, 356:7.9-26, 2000.
- Hochman, J. S. Cardiogenic shock complicating acute myocardial infarction. Expanding the paradigm. *Circulation*, 107:2998-3002, 2003.
- Khan, M. Gabriel, Cardiogenic shock, In *Heart Disease Diagnosis and Therapy*, second edition, New Jersey: Humana Press, 2005.
- Sanborn, T. A., Sleeper, L. A., Webb, J. G. et al. Correlates of one year survival in patients with cardiogenic shock complicating acute myocardial infarction. *J. Am. Coll. Cardiol.*, 42:1373-1379, 2003.

Cardiomyopathy

- I. Hypertrophic Cardiomyopathy
- II. Sudden Death
- III. Dilated Cardiomyopathy
- IV. Restrictive Cardiomyopathy
- V. Specific Heart Muscle Disease

GLOSSARY

heart failure a failure of the heart to pump sufficient blood from the chambers into the aorta; inadequate supply of blood reaches organs and tissues.

hemodynamics the study of the movement of blood and the forces involved in the circulation of blood.

mutations a permanent transmissible change in the genetic material.

outflow tract gradient marked thickness of the left ventricular septum obstructs the blood flow from the left ventricle that is to be delivered into the aorta.

paroxysmal nocturnal dyspnea patient awakens at night from sleep with severe shortness of breath and must dangle the legs or walk to an open window; relief occurs only after several minutes.

sarcomere the contractile unit of a myofibril; sarcomeres are repeating units, delimited by the Z bands, along the length of the myofibril that make up the myocardium of the heart.

CARDIOMYOPATHY IS A RARE FORM OF HEART disease that affects only the heart muscle. The term cardiomyopathy is derived from the word cardio, the heart, and myopathy, which indicates a weakness or disturbance of the muscle. Heart muscle diseases of unknown cause are classified under the term cardiomyopathy.

In one form of heart muscle disease, the muscle of the ventricle becomes considerably thickened to the point that the cavity of the left ventricle becomes nearly filled with muscle mass; thus less blood enters the chamber and less blood is expelled into the circulation. Because the muscle is

enlarged, or hypertrophied, the disease is called hypertrophic cardiomyopathy. This is a disease of young adults. See chapter entitled “Athletes and Sudden Cardiac Death.”

The muscle enlargement may be so severe that it obstructs the flow of blood into the aorta, and death may occur suddenly, particularly in individuals from age 12 to 36 years. Some athletes who have died suddenly have had this disease. In some families, hypertrophic cardiomyopathy is caused by mutation in the cardiac myosin gene. Approximately 60% of cases occur in families with an autosomal dominant pattern and 40% of cases are sporadic.

In another form of heart muscle disease, the heart dilates without increasing the size of the muscle. The chambers are swollen, and the muscle becomes weak. This condition often results in failure of the heart to pump blood, which results in heart failure. Heart transplants are required in some of these patients (see the chapter Heart Failure).

Other types of heart muscle diseases may be caused by viruses. Patients with AIDS have had HIV viral infection of the heart muscle. The heart muscle may also be damaged by cocaine, an overload of iron (hemochromatosis), and some inherited conditions.

With different varieties of involvement of the heart muscle, classification became necessary. In the 1970s and 1980s cardiomyopathy was defined as heart muscle disease of unknown cause. The current classifications are:

1. Hypertrophic cardiomyopathy
2. Dilated cardiomyopathy
3. Restrictive cardiomyopathy
4. Arrhythmogenic right ventricular cardiomyopathy (right ventricular dysplasia)
5. Unclassified cardiomyopathy: diseases that do not have features of 1 through 4 and include fibroelastosis and mitochondrial disease
6. Specific cardiomyopathies (specific heart muscle diseases formerly called secondary cardiomyopathy).

Each of these cardiomyopathies will be discussed. Most of these diseases are rare, but hypertrophic cardiomyopathy

has become well-known because it is one of the causes of sudden death in young athletes and young individuals.

I. HYPERTROPHIC CARDIOMYOPATHY

Hypertrophic cardiomyopathy (HCM) is found throughout the world with a prevalence in North America of 0.2%. Before the diagnosis of HCM is considered hypertensive heart disease, a major cause of the left ventricle hypertrophy, and other causes of hypertrophy must be excluded. In practice HCM is defined and diagnosed by the demonstration of unexplained left ventricular hypertrophy.

Hypertrophic cardiomyopathy is a disease caused by a wide variety of mutations in genes encoding cardiac sarcomeric proteins, which leads to inappropriate and often severe hypertrophy of the myocardium.

A. Genetics

Approximately 60% of cases are familial and are inherited in a Mendelian single gene autosomal dominant fashion. More than 150 mutations in 10 culprit genes that encode sarcomeric proteins are implicated in this disease. The most common of these culprit genes include:

1. Beta myosin heavy chain (MYH7), approximately 35%
2. Cardiac troponin-2 (TNNT2), approximately 15%
3. Myosin binding protein C genes, approximately 15%
4. Alpha tropomyosin
5. Essential myosin light chain
6. Troponins-I
7. Alpha cardiac actin
8. Regulatory myosin light chain.

Familial HCM can be caused by genetic defects at more than one locus, therefore, it is a genetically heterogeneous disease. The mutations of the troponins-T and some mutations of the beta myosin heavy chain appear to be associated with sudden death more often than other mutations. Some mutations may be associated with a high incidence of sudden cardiac death, whereas others appear to have a more benign course. This has led to the hypothesis that genotyping may facilitate the identification of individuals at risk for sudden death. But there is extreme variability and even mutations that were considered by some to be malignant, MYH7 and TNNT2, often run a benign course. In a study by Ackerman et al. so-called "malignant" mutation was found in only 1% of 293 study patients. The authors concluded that given the low prevalence of malignant MYH7 and TNNT2 mutations

in a large study, genetic testing was unlikely to contribute significantly to risk assessment.

Mutations of the troponins-T gene usually result in only mild or no heart muscle hypertrophy. Some of the sporadic forms of the disease are caused by spontaneous mutations. It is of interest that in some patients with an abnormal gene and normal echocardiography, the most diagnostic and least expensive test is the ECG.

B. Macroscopic Features

There is a marked increase in myocardial mass and the ventricular cavity is encroached upon such that the ventricular cavity becomes smaller and narrowed (see Fig. 1). The marked thickening of the interventricular septum obstructs the free flow of blood from the left ventricle into the aorta, (outflow tract gradient). The left ventricle tends to be involved much more than the right. The degree of hypertrophy and the parts of the heart that are involved are extremely variable. See Figure 1 in the chapter entitled "Athletes and Sudden Cardiac Death." Hypertrophy can be patchy, involving the septum only, the apex of the anterior, and the lateral walls. This type of hypertrophy is often referred to as asymmetric hypertrophy. (Fig. 1). Occasionally the hypertrophy of the heart muscle that is seen in HCM and that observed in highly trained male athletes may be difficult to differentiate.

Hypertrophy of the apex of the heart (apical HCM) is more common in Japan than in other parts of the world. In apical HCM the ECG shows a highly abnormal pattern of giant negative T waves in the precordial ECG leads. Despite the frightfully abnormal looking ECG, patients are often asymptomatic and the disease runs a benign course. Figure 2 shows the ECG in a patient with apical HCM. Figure 3 shows a patient with HCM, mild hypertrophy of the septum, and mild free wall hypertrophy but without significant obstruction of the outflow tract that leads from the left ventricle to the aorta as depicted in Fig. 1.

C. Microscopic Features

Microscopically in HCM the myocytes are hypertrophied and in disarray and there is abundant interstitial fibrosis. Individual myocytes demonstrate disarray in the orientation or their myofibrillar architecture. The disorganization in the alignment of cardiac myocytes is oriented around loose connective tissue. Large areas of fibrosis are observed throughout the affected muscle. This microscopic picture may also be seen in muscle where there is no obvious hypertrophy.

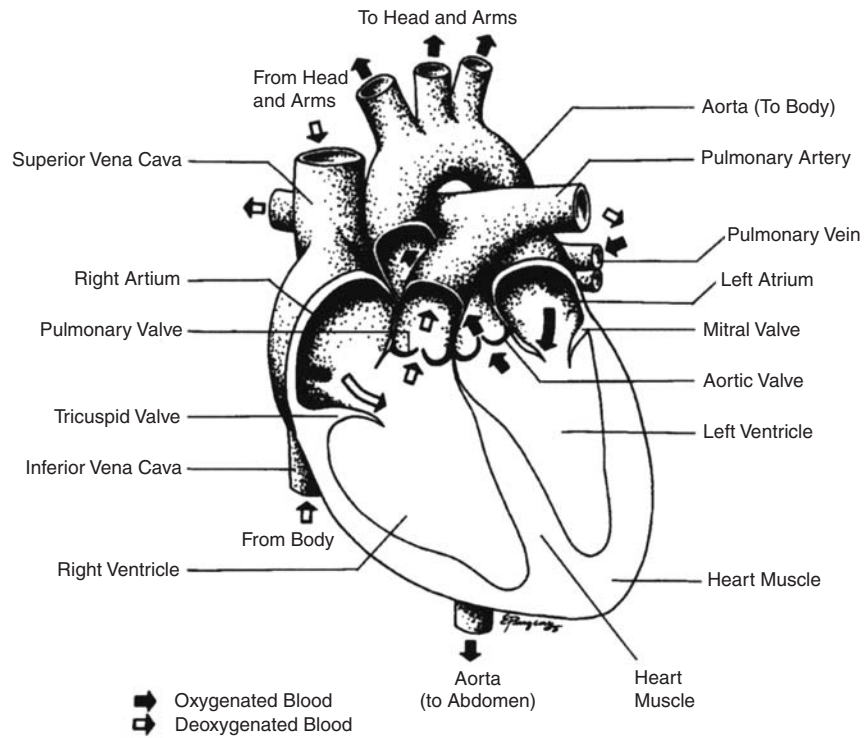

FIGURE IA Normal heart. (From Khan, M.G. and Marriott, H.J.L. (1996). *Valve diseases, Heart Trouble Encyclopedia*, Toronto: Stoddart Publishing, p. 267.)

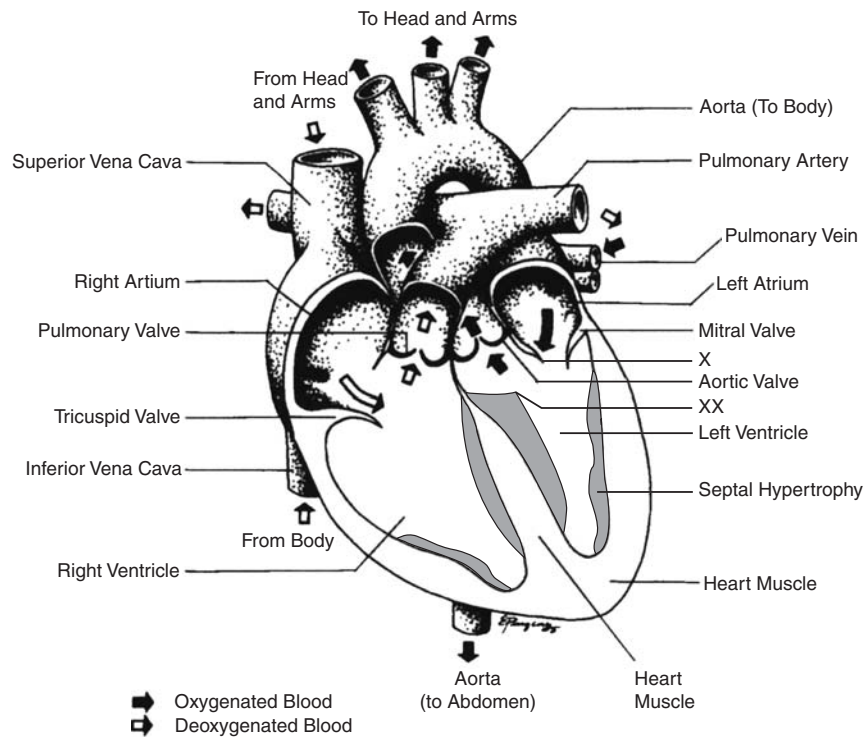

FIGURE IB Adjacent mitral valve (X) leaflet impinges on the hypertrophied septum (XX).

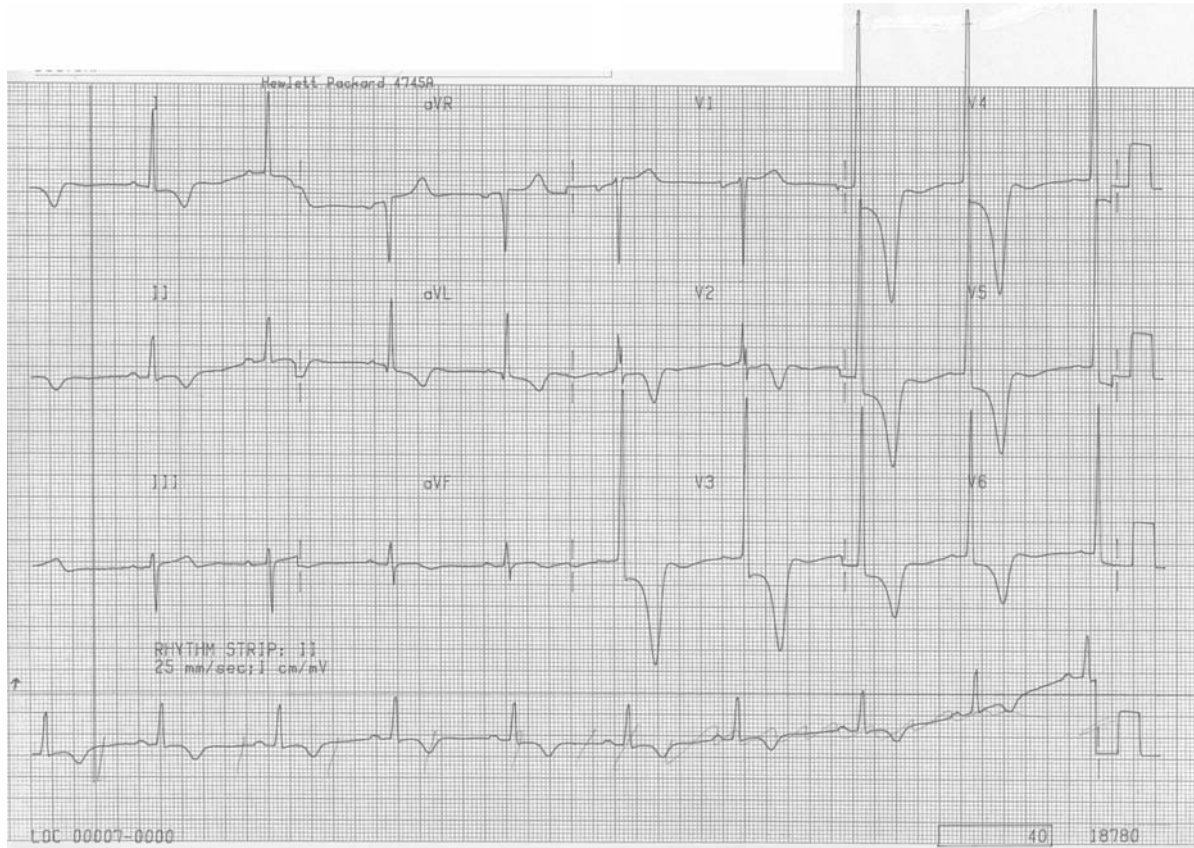

FIGURE 2 Giant T-wave inversion leads v2-v6 in a patient with apical hypertrophic cardiomyopathy.

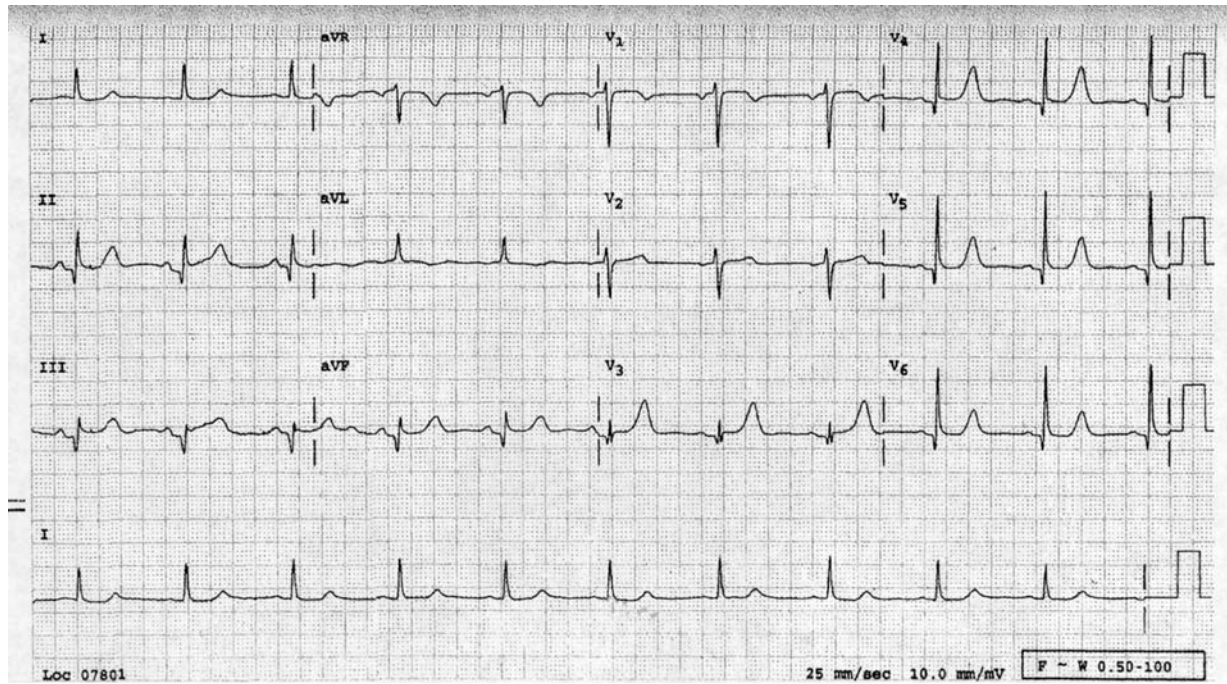

FIGURE 3 Hypertrophic cardiomyopathy simulating inferolateral infarction. Q waves leads 2, 3, aVF, V4 to V6; note the positive T waves.

D. Pathophysiology

1. Most patients show asymmetric hypertrophy of the septum and a hypertrophied nondilated left and or right ventricle. The septum may be diffusely hypertrophied or only in its upper, mid, or apical portion. Hypertrophy extends to the free wall of the left ventricle.
2. There is decreased compliance and incomplete relaxation of the thickened and stiff left ventricular muscle that causes impedance to filling of the ventricles during diastole (diastolic dysfunction)
3. The rapid powerful contraction of hypertrophied left ventricle expels most of its contents during the first half of systole. This hyperdynamic systolic function is apparent in most patients with HCM.
4. The anterior leaflet of the mitral valve is displaced toward the hypertrophied septum. Mitral regurgitation is virtually always present in the obstructive phase of the disease.
5. Because of the obstruction overflow from the left ventricle into the aorta and outflow pressure gradient at rest, HCM is much worse during exercise in more than 40% of patients.
6. Disease of small branches of the coronary arteries may occur, but the major coronary arteries are not obstructed.

E. Clinical Features

1. Shortness of breath commonly occurs but may not be noticeable in many patients until the obstruction to outflow of the left ventricle becomes severe.
2. Fainting, syncope, or presyncope during exercise or during normal activities is a warning signal.
3. Chest pain may occur because of restricted flow to the coronary arteries.
4. Abnormal heart rhythms causing palpitations may occur.
5. On examination, hypertrophy of the heart is reflected by a thrusting and forceful apex beat of the heart that can be seen or felt with the palpating hand. A murmur is heard with the stethoscope and has typical characteristics, but the entire examination may reveal little or no abnormalities depending on the stage of the disease.
6. The ECG is usually abnormal with pathologic Q waves in leads I, II, III, aVF, V5, and V6, as shown in Fig. 3.

7. Signs of heart failure are observed in the end stages of the disease. Figure 4 gives an outline of various processes that lead to the end stages which culminate in heart failure or death.

II. SUDDEN DEATH

Death is most often sudden in HCM and unfortunately this may occur in asymptomatic patients, in those who were unaware that they have the disease, or in individuals with an otherwise stable course.

The mechanisms that result in sudden death remain unresolved. The identification of patients at high risk of sudden death presents great difficulties for the average and expert clinicians.

A. Genotyping

Genotyping is not available as a routine clinical test, and most important, it is currently problematic in prognostic assessment. The findings of Ackerman et al. of only 1% malignant mutation in 293 patients is important and is in keeping with several other observations. Even within so-called high-risk families there is a variable disease expression and prognosis. Watkins et al. described a large Scottish family with mutation in *TNNT2* in which 8 died suddenly before age 30, but 8 others lived to be 70–80 years old. Several other reports of this type have been noted.

B. Clinical Evaluation

Because the promise held for genotyping is not likely to materialize, assessment of risk is based mainly on clinical evaluation and specific investigations. Clinical parameters that may assist in the assessment of risk for sudden death, however, remain unsystematic and haphazard. McKenna et al. made the point that at best, clinical risk markers are only modestly predictive of short-to-medium term risk of sudden death. The presence of a severe outflow tract gradient does not correlate with the risk of sudden death.

C. Marked Left Ventricular Hypertrophy

Current evidence indicates that marked left ventricular hypertrophy should not be relied upon for diagnosis. Some studies indicate that left ventricular wall thickness greater than 30 mm significantly increases the risk of sudden

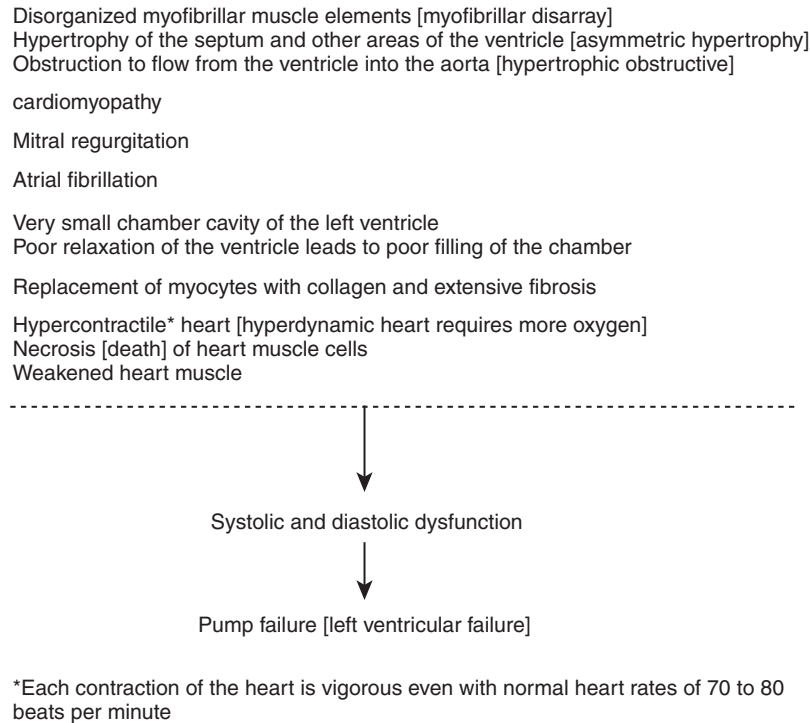

FIGURE 4 Hypertrophic cardiomyopathy: processes that lead to end stage disease and heart failure.

death. In a study by Spirito et al. sudden death occurred in less than 1% of patients with maximal thickness less than 20 mm and in 16% of patients with maximal thickness greater than 30 mm over the average follow up of 7 years. Unfortunately at least 10% of patients in most survival studies show a left ventricular wall thickness greater than 30 mm. Most important, the majority of sudden cardiac death in patients with HCM occurs in those with a wall thickness of less than 30 mm.

Survivors of cardiac arrest make up a high-risk group that is easy to define. These are individuals who have survived an episode of sustained ventricular tachycardia. These patients have about an 8% chance of further cardiac event in five years.

A history of sudden death in the family or syncope in an individual is worrisome, and there is considerable anecdotal evidence to suggest that these two features carry a sizable predictive risk. The worry to the family and individual is understandable. The outcome statistical analyses in large series show that syncope and a previous history of sudden death are not reliable indicators, however, for the prediction of future sudden death. Syncope is more sinister in children with HCM than in adults.

Findings of nonsustained ventricular tachycardia on Holter electrocardiographic ambulatory monitoring and an abnormal blood pressure response on exercise along

with clinical evaluation (massive left ventricular hypertrophy) and family history (unexplained syncope, family history of sudden death) are useful toward a diagnosis. In a prospective study in which these parameters were present, there was an annual sudden death risk of approximately 3%.

A group at low risk for sudden death may be identified as asymptomatic patients with left ventricular thickness less than 20 mm, absence of nonsustained ventricular tachycardia on Holter monitoring, normal exercise blood pressure response, and no family history of sudden death.

D. Management

I. Medical

Beta-blockers are the mainstay of medical therapy. Drug management is used mainly in patients who are symptomatic and in patients who present with chest pain, mild shortness of breath, or presyncope. A marked increase in vigorous contractions of the heart muscle (hypercontractility) dictates the need for more oxygen by the thickened muscle; beta-blocking drugs such as metoprolol, which decreases the force and velocity of contraction of the ventricle, and decreases oxygen requirement, have been used successfully for more than 30 years to achieve subjective and objective benefit in a significant number of

patients. Also, in patients with HCM the heart rate is slow and this leads to improved filling of the ventricle during diastole and increased filling of the coronary arteries that supply the thickened muscle with blood and oxygen. Beta-blocking agents, however, have not been shown to prevent sudden death and clinical trials are difficult in patients with HCM. Other agents used in selected cases include verapamil, which may precipitate heart failure and hypotension in some. Verapamil improves relaxation of the ventricle and allows for better filling of the left ventricle, but it should be avoided in patients who are at risk for development of heart failure.

Diuretics may cause dehydration because of the removal of salt and water from the body. This effect decreases the volume of blood returned to the heart, and this may have serious consequences in patients who already have poor filling of the left ventricle.

2. Chemical Septal Ablation

This technique is used mainly in highly symptomatic patients who have contraindications or are resistant to drug treatment. In these patients the outflow tract gradient at rest should be greater than 30 mmHg or greater than 60 mmHg with provocation. The septum usually measures greater than 18 mm thick. Catheterization of the target vessel (the most important proximal septal artery that supplies the septum with blood) and ablation of the area with the use of alcohol appears to produce satisfactory results in selected patients. Complications include complete heart block, damage to a coronary artery, myocardial infarction, and pericardial tamponade. Hospital mortality ranges from 1 to 4%.

3. Surgical Myomectomy

Surgical removal of excess muscle tissue in the region of the thickened septum is a logical solution to reduce outflow tract gradient and promote better flow of blood from the left ventricle into the aorta. In 1957 Brock advanced this method, and subsequently Morrow popularized the technique. A portion of the thickened interventricular septum is excised; often the mitral valve is replaced. Symptoms are definitely improved, but the mortality rate ranges from 2 to 5%. Surgical intervention is usually satisfactory; long-term improvement in symptoms and exercise capacity is observed in most patients.

4. Dual-Chamber Pacemaker

Dual-chamber pacemaker insertion is based on the observation that excitation of the septum by pacing causes the

septum to contract away from the opposing wall reducing the obstruction to outflow of blood from the ventricle (reduces the left ventricular outflow tract gradient). This strategy appeared useful in the European trial, but several trials in the United States have failed to show significant benefit.

III. DILATED CARDIOMYOPATHY

Heart failure is rare in individuals younger than age 20. If congenital heart disease is excluded, the most common cause of heart failure in the young is idiopathic dilated cardiomyopathy (DCM). More than 50 known specific diseases of heart muscle can produce the signs, symptoms, and manifestations of idiopathic DCM. Some of these diseases include the following:

1. Infectious: Coxsackie, cytomegalovirus, HIV, Chagas disease, tuberculosis, acute rheumatic fever, toxoplasmosis, trichinosis, echinococcus, schistosomiasis, and Lyme disease
2. Endocrine: Thyroid diseases (thyrotoxicosis and hypothyroidism), diabetes, and acromegaly
3. Infiltrative diseases: Amyloidosis, hemochromatosis, and sarcoidosis
4. Alcoholic cardiomyopathy
5. Collagen vascular disease: Lupus erythematosus, scleroderma, mixed connective tissue disease, polyarteritis nodosa, and rheumatoid arthritis
6. Toxic: Cocaine, heroin, amphetamines, cancer chemotherapeutic agents, arsenic, cobalt, lead, phosphorus, and ethylene glycol
7. Nutritional: Thiamine, protein, and selenium
8. Others: Endomyocardial fibroelastosis, peripartum, and sleep apnea

Idiopathic DCM is transmitted in an autosomal dominant manner although X-linked, autosomal recessive, and mitochondrial inheritance also have been observed.

A. Genetics

Shaw et al. stated in an editorial that the genetic heterogeneity of DCM is illustrated by the autosomal dominant form with several foci and gene mutations identified that include Iq32 (cardiac troponin-T), 14q11 (beta myosin heavy chain), 4q12 (beta -sarcoglycan), and 15q14(actin). Figure 5 shows some proteins involved in DCM and their cellular location.

The mechanisms by which individual mutations cause idiopathic DCM require further clarification. The end

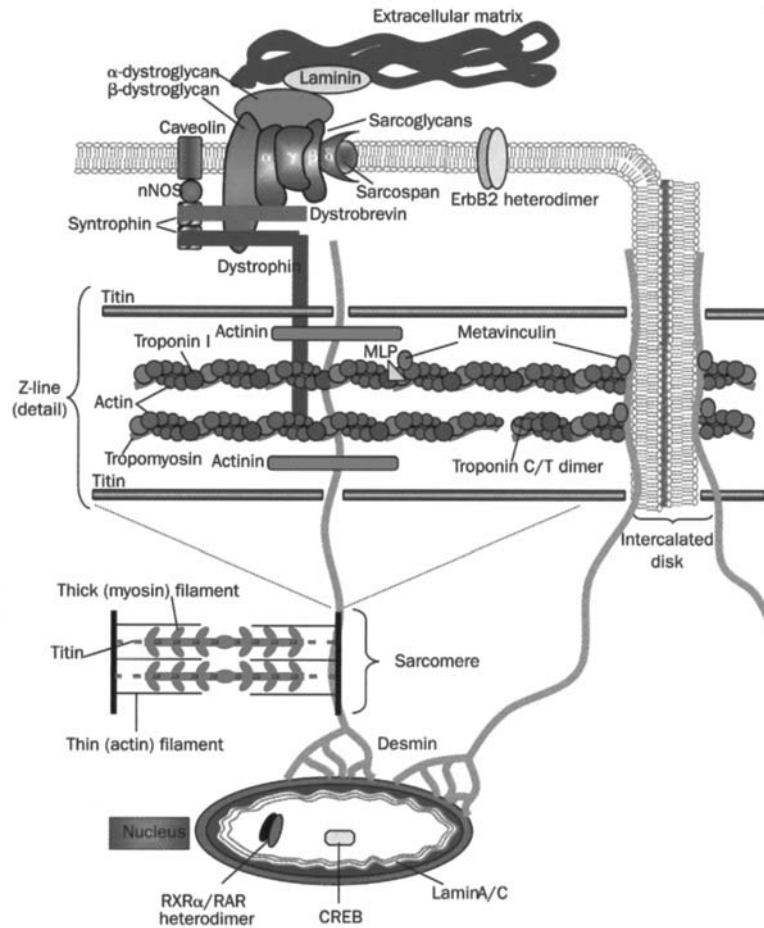

Starting from nucleus both RXR α and CREB have been implicated in DCM. Mutations in genes encoding nuclear lamin A/C and intermediate filament protein, desmin, are known to cause DCM. Desmin is found in Z-line of sarcomere and in intercalated discs joining cardiomyocytes. Simplified sarcomere is shown to highlight positions of thick and thin filaments relative to Z-line, which is shown in more detail. Intercalated disc is shown without characteristic stepped profile, desmosomes, and gap junctions for clarity. MLP=muscle LIM protein, CREB=cyclic AMP response element binding-protein, nNOS=neuronal nitric oxide synthase, RXR α =retinoid X receptor alpha. Adapted from ref 6, with permission.

FIGURE 5 Cardiomyocyte showing some proteins involved in development of DCM. (From *The Lancet*, 360, 654, 2002. With permission.)

result of the disease is a weakened heart muscle that leads to heart failure. Abnormalities in force transmission and velocity of contraction of the heart muscle appear to result from mutations of contractile proteins, actin, alpha-tropomyosin, and desmin. Cardiac beta myosin heavy chain and troponins-T mutations are believed to result in reduced force generation by the sarcomere. Mutations in both sarcoglycans are believed to cause DCM. Mutations in the mitochondrial respiratory chain also can lead to DCM.

B. Clinical Features

1. Progressive shortness of breath on exertion appears over weeks or months. This then progresses to shortness of

breath in bed (orthopnea) and paroxysmal nocturnal dyspnea.

2. Signs and symptoms of right and left heart failure become evident.
3. On auscultation gallop sounds are typically present.

C. Investigations

1. Chest x-ray shows enlargement of the heart with fluid in the lungs (pleural effusions) and evidence of heart failure.
2. Echocardiogram shows enlargement of all four chambers and the entire muscle wall contracts poorly (global hypokinesis). A pericardial effusion (excess fluid in the pericardial sac) can be seen.

D. Management

Transplantation has a role in selected individuals but does not benefit patients worldwide. Aggressive treatment for heart failure carries the only hope for improved survival and must include the following medications:

1. Diuretics: Furosemide in a dosage to prevent fluid retention, edema, signs of heart failure, and particularly for the relief of shortness of breath.
2. ACE inhibitor therapy: Enalapril or lisinopril or similar ACE inhibitor, see the chapter Heart Failure.
3. Beta blockers: The use of metoprolol or carvedilol is now recognized as essential. These agents have recently been shown to be effective in relieving symptoms as well as improving cardiac function. Lowes et al. reported the study of 53 patients treated with metoprolol or carvedilol and observed significant improvement that was associated with changes in myocardial gene expression. A study by Cice et al. in 114 dialysis patients with dilated cardiomyopathy treated with carvedilol showed a reduction in left ventricular function, left ventricular volumes, and clinical status.
4. Spironolactone: Added to the above beta-blockers further improves clinical status survival and decreases hospitalization for heart failure.
5. Dual-chamber electronic pacing: In patients with heart failure and intraventricular conduction delay (IVCD), this has shown significant benefit, reduced hospitalization, and probably will delay the time to transplantation in individuals on waiting lists.
6. Anticoagulants: These may be required to reduce the risk of embolism that occurs frequently in patients with dilated hearts.
7. Antiarrhythmics: In some of these patients implantation of an IVCD may become necessary.

IV. RESTRICTIVE CARDIOMYOPATHY

Restrictive cardiomyopathy is rare in the western world and in Europe. Diseases that cause damage to the muscle and restrict the flow of blood into the ventricle include amyloidosis, sarcoidosis, hemochromatosis, scleroderma, Adriamycin toxicity, and heart involvement by infectious agents. The most common cause of restrictive cardiomyopathy, especially in tropical regions, is endomyocardial fibrosis.

The damage to the muscle in these diseases causes the ventricular walls to become excessively rigid and the main abnormality is impaired relaxation and compliance that impedes the filling of the ventricle. Less blood is held

within the ventricle and thus less blood is expelled into the aorta and systemic circulation. When the supply of blood to organs becomes inadequate, heart failure is diagnosed. This situation is due mainly to poor diastolic filling of the ventricle rather than to a decrease in the force of contraction of the ventricular muscle (systolic dysfunction) which is the most common cause for heart failure.

A. Clinical Features

In the tropics endomyocardial fibrosis may result in intermittent fever, shortness of breath, cough, palpitations, edema, and tiredness. Symptoms and signs of heart failure must be differentiated from constrictive pericarditis. Endomyocardial fibrosis may mimic the hemodynamic and clinical features of constrictive peritonitis. Chest x-ray or fluoroscopy may show calcification of the right and left ventricular apical myocardium due to thrombus formation, calcification of all fibrosis, and calcification of the endocardial region. The apex of the heart may be completely obliterated. Blood tests may reveal increased eosinophils (hypereosinophilia). Echocardiogram typically shows obliteration of the apices of the ventricle with echogenic masses. Also, extensive myocardial calcification may be detected.

B. Management

1. Steroids may be helpful to subdue inflammatory changes.
2. Anticoagulants are advisable to prevent thromboembolism.
3. Arrhythmias may respond to small doses of a beta-blockers and occasionally some beneficial response may be obtained with ACE inhibitors.
4. Diuretics are usually not beneficial, but may be required for symptomatic relief of shortness of breath and other manifestations of heart failure.

V. SPECIFIC HEART MUSCLE DISEASE

Specific heart muscle disease usually produces a dilated form of cardiomyopathy with impaired systolic function. Restrictive physiology is seen with amyloid, sarcoid, neoplasm, radiation, scleroderma, hemochromatosis, and eosinophilic endomyocardial disease, in which eosinophilia is usually present. Rarely, myocardial tuberculosis is present with restrictive features. Amyloid heart disease and EMF are usually considered examples of RCM, but when

TABLE I
Principal Causes of Specific Heart Muscle Disease

Bacterial:	Diphtheria, tuberculosis
Parasitic:	Chagas' disease, toxoplasmosis, trichinosis, Echinococcus
Viral:	coxsackie, cytomegalovirus, HIV, Epstein-Barr Kawasaki disease
Collagen vascular:	Lupus erythematosus, scleroderma, mixed connective tissue disease, polyarteritis nodosa, rheumatoid arthritis
Metabolic and dietary disorders:	Thiamine, selenium deficiency; glycogen storage disease
Toxic:	Adriamycin, doxorubicin, cocaine, cobalt, ethanol, lead
Chemotherapeutic agents:	Mercury, prednisone, zidovudine, X radiation, and allergic reactions
Neuromuscular:	Duchenne's muscular dystrophy, myotonic dystrophy, Friedreich's ataxia
Endocrine:	Thyroid heart disease, pheochromocytoma, Addison's disease
Granulomata:	Sarcoidosis
Others:	Amyloid (see text), hemochromatosis

cardiac involvement is associated with multiple organ disease, they qualify as specific heart muscle disease (see Table 1).

Endomyocardial biopsy is often required but may not be helpful in patchy disease such as sarcoid. The presence of systemic disease of other organs, especially the liver, lymph nodes, and skin, which can be easily submitted to biopsy, assist in defining the underlying cause.

Amyloidosis causes deposition of specific proteins as insoluble fibrils in the extracellular space of several organs including the heart. The disease affects individuals in the fifth and sixth decade of life. The heart muscle is weakened and mainly right heart failure ensues in more than 40% of patients.

BIBLIOGRAPHY

- Ackerman, M. J., McKenna, W. J., Thierfelder, L. et al. Mutations in the genes for cardiac troponins T and alpha tropomyosin in hypertrophic cardiomyopathy. *N. Engl. J. Med.*, 332:1058–64, 1995.
- American College of Cardiology/European Society of Cardiology Clinical Expert Consensus Document on Hypertrophic Cardiomyopathy. *J. Am. Coll. Cardiol.*, 42:1688–1713, 2003.
- Boriani, G., Maron, B. J., Win-Kuang, S. et al. Prevention of sudden death in hypertrophic cardiomyopathy: But which defibrillator for which patient? *Circulation*, 110:e438–e442, 2004.
- Braunwald, E., Seidman, C. E., and Sigwart, U. Contemporary evaluation and management of hypertrophic cardiomyopathy. *Circulation*, 106:1312–1316, 2002.
- Brock, R. Functional obstruction of the left ventricle. *Guy's Hospital Rev.*, 106:221, 1957.
- Canon, R. O. Assessing risk in hypertrophic cardiomyopathy. *N. Engl. J. Med.*, 349:1016–18, 2003.
- Cice, G., Ferrara, L., Benedetto, A. D. et al. Dilated cardiomyopathy in dialysis patients. Beneficial effects of carvedilol, a double-blind, placebo-controlled trial. *J. Am. Coll. Cardiol.*, 57:47–11, 2001.
- Elliott, P. M., Blanes, G., Mahon, J. R. et al. A relation between the severity of left ventricular hypertrophy and prognosis in patients with hypertrophic cardiomyopathy. *Lancet*, 357:420–24, 2001.
- Eriksson, M. J., Sonnenberg, B., Woo, A. et al. Long-term outcome in patients with apical hypertrophic cardiomyopathy. *J. Am. Coll. Cardiol.*, 39:638–45, 2002.
- Kühl, U., Pauschinger, M., Noutsias, M., Seeborg, B., Bock, T., Lassner, D., Poller, W., Kandolf, R., Schultheiss, H. P. et al. High prevalence of viral genomes and multiple viral infections in the myocardium of adults with "idiopathic" left ventricular dysfunction. *Circulation*, 111:887–893, 2005.
- Lowes, B. D., Gilbert, E. M., Abraham, W. T. et al. Myocardial gene expression in dilated cardiomyopathy treated with beta blocking agents. *N. Engl. J. Med.*, 346:1357–65, 2002.
- Maron, B. J., Dearani, J. A., Ommen, S. R. et al. The case for surgery in obstructive hypertrophic cardiomyopathy. *J. Am. Coll. Cardiol.*, 44:2044–2053, 2004.
- Maron, B. J., Seidman, J. G., Seidman, C. E. et al. Proposal for contemporary screening strategies in families with hypertrophic cardiomyopathy. *J. Am. Coll. Cardiol.*, 44:2125–2132, 2004.
- Maron, B. J. Sudden death in young athletes. *N. Engl. J. Med.*, 349:1064–1075, 2003.
- Maron, B. J., Estes, N. A., III, Maron, M. S., Almquist, A. K., Link, M. S., and Udelson, J. E. Primary prevention of sudden death as a novel treatment strategy in hypertrophic cardiomyopathy. *Circulation*, 107:2872–2875, 2003.
- McKenna, W. J., Mogensen, J., and Elliott, P. M. Role of genotype in risk factor assessment for sudden death in hypertrophic cardiomyopathy. *J. Am. Coll. Med.*, 39:249–51, 2002.
- Morrow, A. G. Hypertrophic subaortic stenosis: operative methods utilized to relieve left ventricular outflow obstruction. *J. Thorac. Cardiovasc. Surg.*, 76:423–430, 1978.
- Nishimura, R. A., and Holmes, D. R. Hypertrophic obstructive cardiomyopathy. *N. Engl. J. Med.*, 350:1320–1327.
- Ommen, S. R., and Nishimura, R. A. Hypertrophic cardiomyopathy: Echocardiographic basis of therapy. *Am. Coll. Cardiol. J. Rev.*, January/February 46–49, 2001.
- Reisinger J, Dubrey SW, Falk RH. Cardiac Amyloidosis. *Cardiology in Review*.5: [6], 317-24, 1997.
- Roberts, R., and Sigwart, U. New concepts in hypertrophic cardiomyopathies, part II. *Circulation*, 104:2249–52, 2001.

- Scheinman, M. M., Crawford, M. H. et al. Echocardiographic findings and the search for a gold standard in patients with arrhythmogenic right ventricular dysplasia. *J. Am. Coll. Cardiol.*, 45:6:866–867.
- Shamim, W., Yousufuddin, M., Wang, D. et al. Nonsurgical reduction of the interventricular septum in patients with hypertrophic cardiomyopathy. *N. Engl. J. Med.*, 347:1326–33, 2002.
- Shaw, T., Elliott, P., and McKenna, W. J. Commentary. Dilated cardiomyopathy: A genetically heterogeneous disease. *Lancet*, 360:654–655, 2002.
- Spirito, P., Bellone, P., Harris, K. M. et al. Magnitude of left ventricular hypertrophy and risk of sudden death in hypertrophic cardiomyopathy. *N. Engl. J. Med.*, 1778–85, 2000.
- Watkins, H., McKenna, W. J., Thierfelder, L. et al. Mutations in the genes for cardiac troponins T and alpha tropomyosin in hypertrophic cardiomyopathy. *N. Engl. J. Med.*, 332:1058–64, 1995.
- Wigle, E. D., Schwartz, L., Woo, A. et al. To ablate or operate? That is the question. *J. Am. Coll. Cardiol.*, 38:1707–1710, 2001.
- Yoerger, D. M., Marcus, F., Sherrill, D. et al. Echocardiographic findings in patients meeting task force criteria for arrhythmogenic right ventricular dysplasia: New insights from the multidisciplinary study of right ventricular dysplasia. *J. Am. Coll. Cardiol.*, 45:6:860–865.

Cardiopulmonary Resuscitation (CPR)

- I. Causes of Loss of Consciousness
- II. Cardiac Arrest Rhythms
- III. Cardiopulmonary Resuscitation
- IV. Defibrillation
- V. Drugs for Cardiac Arrest
- VI. Perspectives and Research Implications
- VII. Outcomes of Out-of-Hospital Cardiac Arrest
- VIII. The Heimlich Maneuver

GLOSSARY

cardiac output the volume of blood pumped by the ventricles per unit of time expressed in liters per minute; it is a function of the stroke volume multiplied by the heart rate.

cardiac tamponade compression of the heart by fluid in the pericardial sac causing hemodynamic compromise that leads to cardiogenic shock and death if not immediately corrected.

hyperkalemia high levels of serum potassium.

myocardial infarction death of an area of heart muscle due to blockage of a coronary artery by blood clot and atheroma; medical term for a heart attack or coronary thrombosis.

syncope temporary loss of consciousness caused by lack of blood supply to the brain; fainting describes a simple syncopal attack.

ventricular fibrillation the heart muscle does not contract but quivers; therefore, there is no heartbeat (cardiac arrest) and no blood is pumped out of the heart; death occurs within minutes if the abnormal heart rhythm is not corrected.

PERHAPS YOU MAY HAPPEN TO BE NEAR someone who falls to the ground and stops breathing. You may be alone or someone summons you to help. Can you help? If you have never learned how to do CPR, you will not know what to do to save a life. Thus it is wise for all individuals to attend a practical course in CPR or at least read and practice the drill until it becomes automatic.

Since its description more than 43 years ago, the fundamentals of CPR have undergone minimal changes. The technique is quite simple. The main goal in applying

CPR is trying to get oxygen to the individual's brain to keep it alive until expert help arrives. Mouth-to-mouth ventilation oxygenates the blood, and chest compressions cause forward flow of blood, albeit a small flow, that results in some cardiac output into the circulation so that oxygenated blood reaches vital organs.

In this chapter the relevant points of CPR are summarized so that if you are faced with an individual who has "dropped dead" or appears to have lost consciousness in your presence, you may be able to render assistance.

I. CAUSES OF LOSS OF CONSCIOUSNESS

Patients may lose consciousness and fall because of several reasons such as syncope, seizure, stroke, or cardiac arrest.

A. Syncope/Fainting

With syncope the patient has a pulse, does not stop breathing, and has no shaking of the limbs. Simply keeping the head down, preferably with the individual lying flat, and raising the legs up in the air above the patient's hips will cause blood to flow from the legs. In about one minute the individual will recover completely.

B. Seizure/Epilepsy

During a seizure the patient's limbs exhibit jerky, movements, the limbs get rigid, or there is a combination of rigidity and jerking of one or more limbs. The patient is breathing, but saliva and foam bubble from the mouth. Some individuals pass urine or stool. Recovery is typical.

C. Stroke

During a stroke, circulation to part of the brain is cut off because of a blood clot in an artery in the brain. Strokes usually occur in individuals over age 60. It is rare for the

patient to fall suddenly to the floor without some warning. The patient will have a pulse and breathing will be present. There is no reason to do CPR because the heartbeat, circulation, and respirations have not stopped.

D. Cardiac Arrest

During cardiac arrest, the heart stops beating completely and is at a standstill (asystole) in about 25% of individuals. In about 60–75%, cardiac arrest is due to ventricular fibrillation. Ventricular fibrillation can be treated by an electrical shock, which defibrillates the heart and replaces the ventricular fibrillation with a normal heartbeat.

In standstill or asystole, there is no electrical current in the heart, and using electrical shock is of no value. In a few cases, the heart may commence beating on its own. This condition is called a Stokes-Adams attack, named after the doctors who first described it. A few individuals can be saved by the insertion of a pacemaker if the attack occurs in the hospital.

It is wise for a family member of a heart patient to know how to give CPR. It reassures the patient that something can be done. The knowledgeable individual also feels some sense of confidence, which promotes hope.

Each year approximately a quarter million individuals die suddenly in the United States from coronary artery disease before reaching a hospital; more than half a million have a cardiac arrest and receive CPR during hospitalization.

II. CARDIAC ARREST RHYTHMS

There are only two cardiac arrest rhythms to consider: ventricular fibrillation and pulseless ventricular tachycardia (VF/VT).

A. Ventricular Fibrillation/Pulseless Ventricular Tachycardia

VF is defined as a pulseless chaotic disorganized rhythm with an undulating irregular pattern that varies in size and shape and has a ventricular waveform greater than 150 beats per minute. VT is an irregular wide QRS complex tachycardia (see the chapter Arrhythmias/Palpitations). Patients with VT may remain stable, alert, and have a pulse. Patients with unstable ventricular tachycardia are hemodynamically unstable with a blood pressure of less than 90 mmHg, chest pain, shortness of breath, clouding of consciousness, or rapid loss of consciousness.

The American Heart Association (AHA) Guidelines 2000 for CPR and emergency cardiovascular care advises that in patients with cardiac arrest it is advisable to always assume that the rhythm is VF or pulseless VT. Because individuals who can be saved from cardiac arrest are usually in VF or pulseless VT, the earliest possible delivery of defibrillation is the single most effective intervention. A recent study in Norway, however, indicates that the use of three minutes of CPR prior to defibrillation, rather than immediate defibrillation, resulted in better outcomes among VF patients who received attention more than five minutes after symptom onset. In patients who received defibrillation immediately, 46% achieved a spontaneous palpable pulse on admission versus 56% of those within three minutes of CPR. Further studies are necessary to clarify this finding.

B. Automated External Defibrillator

The distribution of automatic external defibrillators has been widespread. The AHA recommends that all first-responding emergency personnel such as physicians, nurses, emergency medical technicians, paramedics, firefighters, and volunteer emergency personnel be trained and permitted to operate a defibrillator. The defibrillator should be available in all emergency ambulances that engage in the care or transit of cardiac patients.

The automated external defibrillator automatically interprets the cardiac rhythm and, if VF is present, advises the operator to provide a shock. Because most cardiac arrests occur in the home, a case can be made for home defibrillators for patients at high risk. Their size, that of a notebook laptop computer, and costs of approximately \$3000 should both decrease considerably over the next decade.

III. CARDIOPULMONARY RESUSCITATION

CPR is only a temporary measure. The aim is to get blood containing a fresh supply of oxygen to the brain. Therefore, it is necessary to breathe enough air into the patient's lung, then compress the chest to cause the nonbeating heart to expel blood into the arteries. This produces circulation of the blood to the brain. Rarely, the patient may be revived, and the heart begins to beat spontaneously. In patients with ventricular fibrillation, death will occur unless the heart is defibrillated. The hope is that the ambulance has a portable defibrillator and a team that can defibrillate the patient.

A. How to Recognize Cardiac Arrest

First, the patient's level of responsiveness must be determined. If the patient is unresponsive, he is unconscious and oblivious to shaking or commands. Second, determine if the patient is breathing. Within 30 seconds you should have arrived at a conclusion that a cardiac arrest has occurred. Speed of diagnosis is critical. Within three to four minutes of cardiac arrest, irreversible brain damage can occur because of lack of oxygen. The intention is to provide basic life support until advanced life support in the form of expert technical help arrives. When CPR is started within four minutes after collapse, the probability of survival doubles.

In a King's County survey, 46% of patients with VF survived CPR versus only 7% for presumed asystole and pulseless electrical activity (PEA). The incidence of VF in that survey was 45% and asystole/PEA 41%. Thus close to 50% of patients with VF can be resuscitated with efficient CPR, but less than 10% with other rhythms can be resuscitated.

B. The Steps of CPR

AHA Guidelines provide the following steps for CPR (see Fig. 1):

- Check responsiveness
- Open the airway
- Check breathing
- Give two effective breaths
- Access the circulation
- Compress the chest (see Fig. 2)

I. Responsiveness — Airway

CPR should be commenced immediately. First, turn the victim flat on the back on a hard surface (preferably the floor). Quickly assess head tilt for responsiveness and loss of consciousness. Figure 2 shows the use of the head tilt/chin lift maneuver to open the airway. One hand is placed on the victim's forehead and firm backward pressure is applied with the palm to tilt the head back. The index and middle finger of the other hand are placed under the bony parts of the lower jaw. The chin is lifted forward and the jaw is supported. Avoid pressing the fingers into the soft tissue under the chin. This maneuver should bring the teeth almost together and maintain dentures in position.

2. Breathing

Place your ear over the victim's mouth and nose. If you do not hear or feel the flow of air escaping and the chest does

not rise and fall, the victim is not breathing. Pinch the victim's nostrils closed, using your thumb and index finger of the hand on the forehead. Then take a deep breath, make a tight seal over the victim's mouth with your mouth, and blow into the victim's mouth. Blow air into the victim's mouth to fill the lungs (ventilate) rapidly two times allowing the chest to deflate totally between each breath.

C. Circulation

I. The Pulse

There is no pulse if cardiac arrest has occurred. Check for a pulse by feeling the carotid artery in the neck. The right carotid artery is felt one inch from the angle of the jaw. Place the index finger in a straight line parallel with the wind pipe (trachea) so that the entire length of the first finger pad is touching the skin. The tip of the index finger should be approximately opposite the Adam's apple. Start by feeling the most prominent part of the Adam's apple with the tips of two fingers, then slide the finger outward to reach the groove between the hard cartilage of the wind pipe and the muscle of the neck. The carotid artery lies only a few millimeters under the skin, and the pulsation is easily felt. Practice feeling this pulse so that you can find it in a hurry, taking no more than 10 seconds.

Evidence has accumulated from the European Resuscitation Council and other international expert panels that the pulse check is not a good diagnostic test for the presence or absence of a beating heart. The pulse is not a satisfactory check for lay responders and they should check for signs of circulation such as any movement including swallowing or breathing that consists of more than an occasional gasp.

2. Chest Compression

Place the heel of one hand over the lower half (see Fig. 1) of the breastbone, but at least one inch (2 cm or two fingerbreadths) away from the end of the breastbone (xiphoid process). Position the heel of your other hand on the top of the first. Keep the fingers off the rib cage. If your hands are too high, ineffective chest compression may result, and fracture of the ribs may occur. Keep your arms straight at the elbow (locked elbows) and apply pressure as vertically as possible. Your shoulders should be directly above the victim's breastbone. Chest compressions are then easily carried out by forceful movements of the shoulders and back, thus the maneuver is less tiring. Depress the

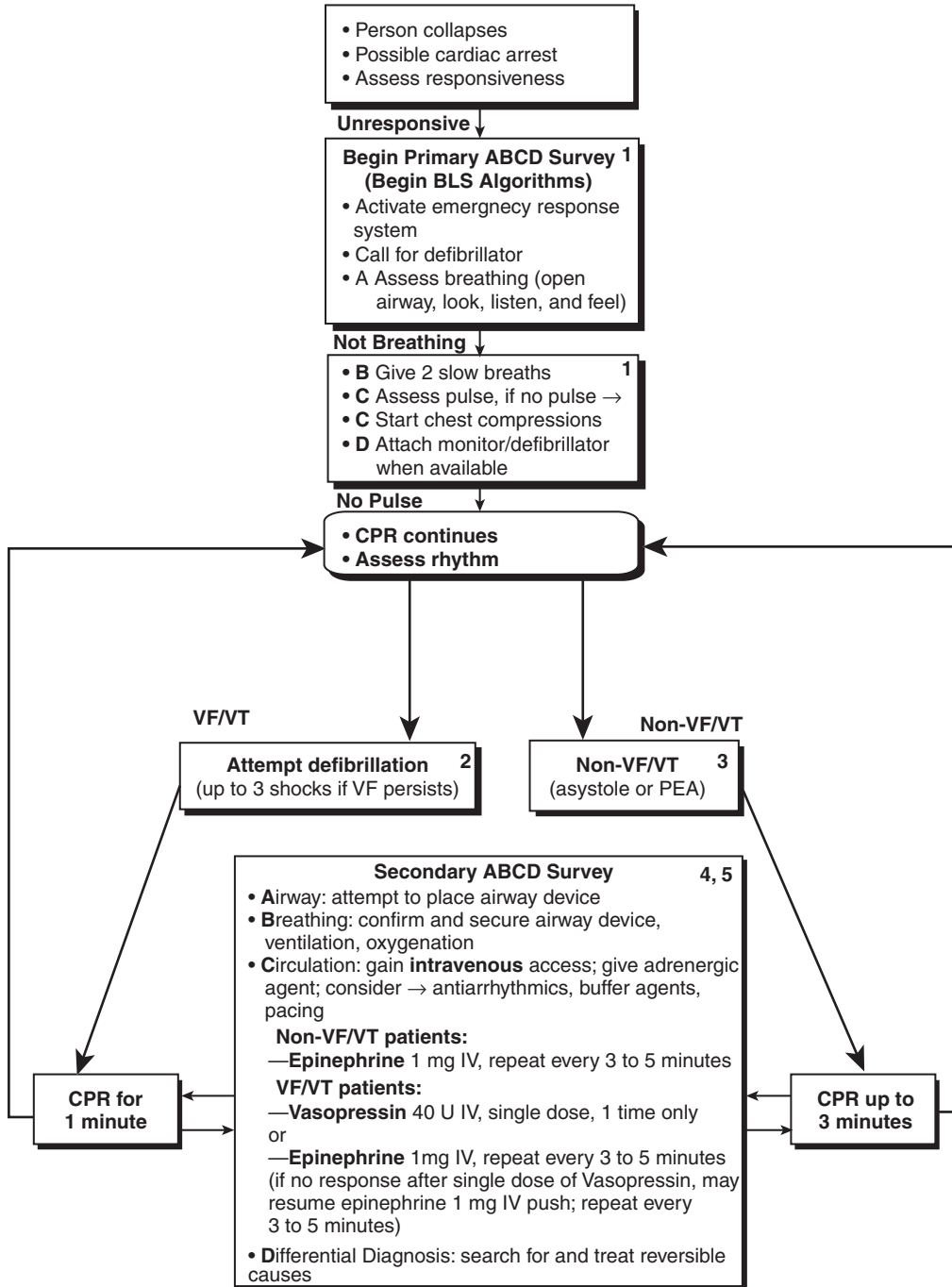

FIGURE 1 Comprehensive ECC algorithm. (From *Circulation*, 200;102(8) Supplement I-142–I-165. Copyright 2000 American Heart Association, Inc.)

breastbone one to two inches (3–5 cm) toward the spine; alternately compress and relax.

The compression rate should be about 90–100 compressions per minute. At the end of the 15th compression two full breaths are given. CPR should never be interrupted for more than five seconds, and it should be continued until skilled help arrives. Endotracheal intubation

should be accomplished within 30 seconds of cessation of CPR.

Note that the victim’s mouth should be almost completely closed, however, depress the lower lip a bit so that the mouth remains slightly open. If dentures cannot be managed in place, remove them after first giving the very important first two breaths. You must see the chest rise and

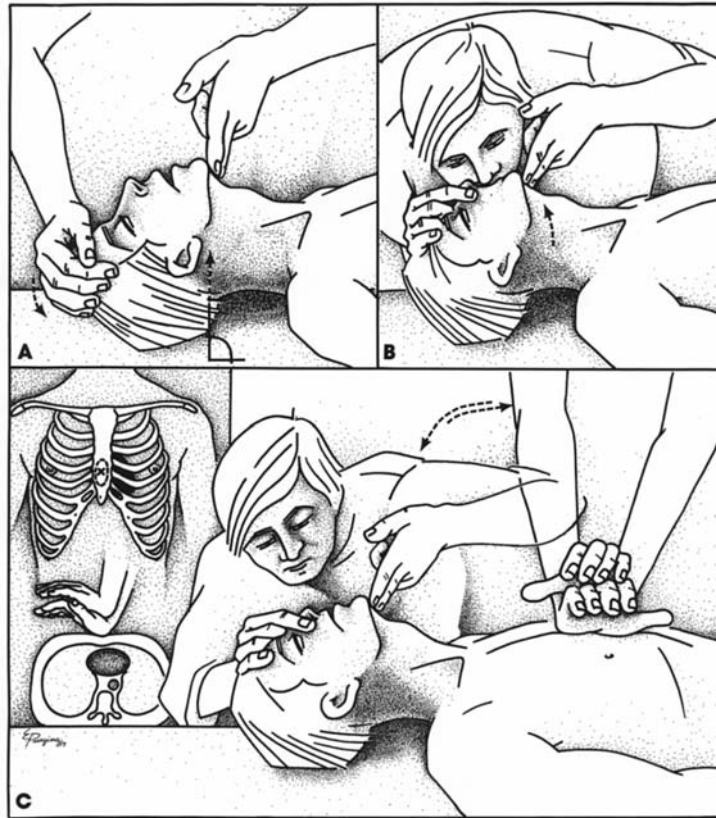

FIGURE 2 Basic life support. (From Khan, M. Gabriel, *Cardiopulmonary resuscitation*, in *Cardiac Drug Therapy*, sixth edition, Philadelphia: W. B. Saunders.)

fall. If the first two breaths meet with resistance and the chest fails to rise when you breathe air into the patient's mouth, make sure that the airway is properly opened by the head tilt/chin lift method and that the seal around the mouth is airtight. Then clear the airway with your fingers if necessary. The fact that the patient suddenly dropped to the ground and was not choking while eating is sufficient to persuade you not to waste time searching for meat or vomitus.

IV. DEFIBRILLATION

The first shock setting should be 200 joules followed by a second shock of 300 joules. One defibrillator paddle is positioned to the right of the sternum below the clavicle. The other paddle is placed to the left of the left nipple with the center of the paddle in the mid-axillary line. An appropriate gel is one that has a low impedance. Because gel spreads during chest compression, shocks may arc across the chest surface thus, the gel must be towed off. Conducting gel pads should be used but must be

changed between shocks. Heavy arm pressure should be applied to each paddle applied to the chest and defibrillation should take place when the victim's phase of ventilation is in full expiration. In the UK the lower paddle is placed over the points designated as V4 and V5 for the ECG, that is, a little outside the position of the normal apex beat. The paddle should be placed at least five inches away from a pacemaker generator.

The area around the patient should be checked so that no personnel are directly or indirectly in contact with the patient. The operator must not touch the patient when the shock is delivered. Deliver countershock by depressing both paddle discharge buttons simultaneously. If no skeletal muscle contraction is observed, check the equipment.

After countershock reassess the cardiac rhythm. If VF persists repeat the shock as soon as possible and continue CPR during any delays. If an organized rhythm is restored, check immediately for a pulse. If no pulse is present resume CPR.

Ventricular asystole causing cardiac arrest indicates a poor prognosis. After CPR is initiated epinephrine is given. Occasionally VF may masquerade as asystole.

The monitoring electrodes should be repeated from the original positioned to ensure that VF is not present. Asystole or electromechanical dissociation is usually caused by irreversible myocardial damage that is extensive with a poor prognosis.

A. Errors in Defibrillation

Eisenberg and Mengert emphasized the following common errors in CPR. Defibrillation errors may occur if the synchronized mode is accidentally selected before defibrillation is attempted, thus no shock is delivered. Asystole may be falsely displayed when the selection is set for paddles and the rescuer believes that rhythm lead II is being displayed. In addition, if a vast amount of chest hair is present it should be shaved off where the paddles are to be placed; smeared gel across the chest should be towed off before defibrillation.

Oxygen at 100% concentration is given as soon as possible through a bag-valve mask or endotracheal tube. Plastic face masks may provide 50–60% oxygen with an oxygen flow rate of 10 L/min.

V. DRUGS FOR CARDIAC ARREST

A. Epinephrine (Adrenaline)

For more than 40 years epinephrine has been a key agent used during cardiac arrest. Epinephrine is both an alpha- and beta-adrenergic agonist; therefore, it stimulates spontaneous cardiac contractions, increases systemic vascular resistance resulting in an increased aortic diastolic perfusion pressure, and improves coronary blood flow. It is relevant that epinephrine constricts peripheral vessels but preserves flow to vital organs causing coronary artery dilation.

Epinephrine is indicated for fine VF, which is rendered more amenable to removal by countershock and for VF that does not respond to electrical countershock. Asystole and pulseless idioventricular rhythms and electromechanical dissociation may respond to this drug, albeit rarely.

A dose of 1 mg IV push every 3–5 minutes (0.01 mg/kg) is recommended. A 20-ml IV fluid flush should be administered to ensure delivery of the drug centrally. A dose of 1 mg/10 ml of a 1:10,000 solution may be given via the tracheobronchial tube.

A higher dose of epinephrine was advocated by the AHA in 1992 based on studies. If the 1-mg IV dose was ineffective, escalating doses of 3 and 5 mg or 5 mg per dose rather than 1 mg were advised; the result of 8 large

randomized trials in patients with cardiac arrest however, showed no significant benefit. The higher dose regimen is no longer recommended.

B. Vasopressin

Vasopressin, a clonal substance antidiuretic hormone, becomes a powerful vasoconstrictor when used at much higher doses than normally present in the body. This drug possesses effects that duplicate the positive effects of epinephrine, but does not duplicate the adverse effects of epinephrine. Only one dose of vasopressin is required. This is less frequent than epinephrine because the 10- to 20-minute half-life of vasopressin is much greater than the 3- to 5-minute half-life of epinephrine. Vasopressin is recommended only for VF/VT; there is no evidence to support its usefulness in asystole or PEA.

Vasopressin is to be administered IV single-dose one time only. If there is no response 5–10 minutes after a single dose of vasopressin, it is advisable to resume epinephrine 1 mg IV push every 3–5 minutes.

C. Amiodarone

Amiodarone is a complex drug which effects sodium, potassium, and calcium channels as well as alpha- and beta-adrenergic blocking properties (see the chapter Arrhythmias/Palpitations). This drug is recommended after defibrillation and epinephrine in cardiac arrest with persistent VT or VF.

The recommended dose is 300 mg IV push. If VF/pulseless VT recurs, consider administration of a second dose of 150 mg IV.

D. Beta-Adrenergic Blocking Agents

The actions and beneficial effects of beta-blockers are given in the chapter Beta-blockers. Atenolol, metoprolol, and propranolol have been shown to reduce the incidence of VF significantly in post-MI patients who did not receive fibrinolytic agents. Beta-blockers have been shown to prevent recurrent VF. VF is unique among cardiac arrhythmias because management with immediate countershock antifibrillatory drugs can be useful. Beta-blockers increase VF threshold and have been shown to be useful in patients who have repetitive VF precipitated by electrocution. Although these agents have a negative inotropic effect, they are not helpful in patients in cardiac arrest.

Metoprolol is administered 5 mg by slow IV push over 5 minutes, at 5-minute intervals for a total 15 mg. Propranolol has been used worldwide and its use continues at a dose of 0.1 mg/kg by slow IV push divided into three equal doses at 2- to 3-minute intervals. The rate of administration should not exceed 1 mg/minute. Esmolol is a short-acting beta-blocking agent with a short half-life of 2–9 minutes. The drug is metabolized by erythrocyte esterases and requires no dose adjustment in patients with renal or hepatic impairment. The dosing regimen is complex and requires an IV infusion pump (see the chapters Beta-Blockers and Arrhythmias/Palpitations).

E. Sodium Bicarbonate

This agent is no longer recommended for routine use except for pre-existing hyperkalemia. Prompt ventilation of the lungs is essential for excretion of carbon dioxide and is the most effective method for combating acidosis.

Sodium bicarbonate may be used to combat bicarbonate responsive acidosis, tricyclic overdose, and after about 10 minutes of ventilation including intubation, defibrillation, and use of epinephrine. If CPR is still necessary, sodium bicarbonate may be used. The drug may also be used on return of circulation after long cardiac arrest, but its use should be guided by arterial pH measurements. The recommended dose is an IV bolus of 1 mEq/kg (~ 50 mEq).

F. Atropine

This drug is of value in the management of severe bradycardia associated with cardiac arrest. Patients with asystole or PEA may respond to atropine while preparations are made for pacing. Patients with a high degree atrioventricular block, slow idioventricular rates, and severe sinus bradycardia with hypotension should be given a trial of atropine IV.

A dose of 1 mg IV repeated in 3–5 minutes is recommended. If asystole persists, the maximum of 3 mg can be administered (0.04 mg/kg).

G. Magnesium Sulfate

Magnesium sulfate is reported to expedite ventricular defibrillation and is indicated for polymorphic ventricular tachycardia, torsades de pointes, and management of hypomagnesemia. A dose of 1–2 mg IV is recommended.

H. Bretylium

Bretylium has been dropped from the VF/pulseless VT algorithm. This drug was used in the 1980s and 1990s for recurrent VF, but was only partially successful and never proven. In the late 1990s, severe problems with obtaining the raw materials curtailed manufacture. The world sources of bretylium appear to be nearly exhausted. Bretylium has a high incidence of side effects including hypotension. It has been replaced by amiodarone and beta-blocking agents.

VI. PERSPECTIVES AND RESEARCH IMPLICATIONS

Automated external defibrillators are now increasingly placed where people congregate such as shopping malls, stadiums, casinos, exercise facilities, airports, and airplanes. They should be in the homes of patients at risk, because the majority of cardiac arrests occur in the home. Most important, a bag-valve mask and an artificial airway should be provided with the defibrillator. This would assist considerably with mouth-to-mouth resuscitation, which has its disadvantages. A miniature apparatus to compress the chest more adequately than the use of the arms would be an advantage.

Intravenous epinephrine has played an important role during the last 40 years and is the main vasopressor used in the management of cardiac arrest. Isoproterenol is contraindicated. Vasopressin is indicated only for VF and pulseless VT with a restriction to one dose. Neo-Synephrine and other agents have also been tried. New vasoactive agents are needed to cause cardiac contractions and produce adequate blood flow to vital organs.

VII. OUTCOMES OF OUT-OF-HOSPITAL CARDIAC ARREST

Bunch et al. conducted a population-based analysis of the long-term outcome and quality of life of survivors of out-of-hospital cardiac arrest from ventricular fibrillation.

Methods: All patients who had an out-of-hospital cardiac arrest and received early defibrillation were included.

Results: Cardiac arrest occurred in 330 patients, VF in 200 (61%), pulseless electrical activity in 58 (18%), and asystole in 72 (22%). Of the 200 VF patients 145 survived to admission, 61 died in hospital, and 84 (42%) were discharged from the hospital – 79 neurologically intact and 5 neurologically impaired.

Among patients who were considered candidates for antiarrhythmic therapy 10 patients received amiodarone alone and 35 (50%) of all neurologically intact survivors received an implantable cardioverter defibrillator. Of the 79 survivors 19 died after hospital discharge. Of 60 patients at five-year follow up 45 were able to return to work and 50 completed the health questionnaire.

Conclusions: Of 330 cardiac arrest victims only 50 patients (15%) were alive and well 5 years later, with 70% having an implantable cardioverter defibrillator.

VIII. THE HEIMLICH MANEUVER

This maneuver is used for removing foreign bodies from the airway. You must stand behind and wrap your arms around the waist of a conscious victim. Then place the thumb side of your fist above the victim's navel and well below the lower tip of the breastbone. Using the other hand, forcefully push the fist with a quick upward thrust into the victim's abdomen. Repeat the thrust a few times if necessary. An unconscious victim is placed face upward. The rescuer kneels and places the heel of one hand above the navel and with the second hand on top pushes into the abdomen with a quick upward thrust.

BIBLIOGRAPHY

- Abella, B. S., Sandbo, N., Vassilatos, P., Alvarado, J. P., O'Hearn, N., Wigder, H. N., Hoffman, P., Tynus, K., Vanden Hoek, T. L., Becker, L. B. et al. Chest compression rates during cardiopulmonary resuscitation are suboptimal: A prospective study during in-hospital cardiac arrest. *Circulation*, 111:428–434, 2005.
- Bunch, T. J., White, R. D., and Gersh, B. J. Long-term outcomes of out of hospital cardiac arrest after successful early defibrillation. *N. Engl. J. Med.*, 348:2626–33, 2003.
- Cummins, R. O., and Eisenberg, M. S. Prehospital cardiopulmonary resuscitation: Is it effective? *JAMA*, 253:2408–12, 1985.
- Eisenberg, M. S., and Mengert, T. J. Cardiac resuscitation. *N. Engl. J. Med.*, 344:1304–13, 2001.
- Guidelines 2000 for Cardiopulmonary Resuscitation and Emergency Cardiovascular Care. The AHA in collaboration with the international liaison committee on resuscitation. *Circulation*, 102 (8 Suppl.):1–142, 2000.
- Kouwenhoven, W. B., Jude, J. R., and Knickerbocker, G. G. Closed chest cardiac massage. *JAMA*, 173:1064–7, 1960.
- Safar, P. Ventilatory efficacy of mouth to mouth artificial respiration: Airway obstruction during manual and mouth to mouth artificial respiration. *JAMA*, 167:355–41, 1958.
- Sanders, A. B., Ewy, G. A. et al. Cardiopulmonary resuscitation in the real world: When will the guidelines get the message? *JAMA*, 293:363–365, 2005.
- Wenzel, V., Krismer, A. C., and Arntz, H. R. A comparison of vasopressin and epinephrine for out-of-hospital cardiopulmonary resuscitation. *N. Engl. J. Med.*, 350:105–113, 2004.
- Wik, L., Kramer-Johansen, J., Myklebust, H., Sørebo, H., Svensson, L. et al. Quality of cardiopulmonary resuscitation during out-of-hospital cardiac arrest. *JAMA*, 293:299–304, 2005.

Chagas Disease

- I. Epidemiology
- II. Symptoms and Signs
- III. Diagnostic Investigations
- IV. Management

GLOSSARY

arrhythmia general term for an irregularity or rapidity of the heartbeat, an abnormal heart rhythm.

cardiomyopathy heart muscle disease.

ejection fraction the fraction of blood ejected from the heart into the arteries, normally this ranges from 60 to 75%; a low ejection fraction is less than 40%; often used as a marker of ventricular contractility.

hypokinesia decreased myocardial contraction usually caused by damage and weakness of the heart muscle due to coronary artery disease and cardiomyopathies.

myocardium the heart muscle.

I. EPIDEMIOLOGY

The protozoan *Trypanosoma cruzi* causes Chagas disease, which affects more than 30 million individuals, with approximately 100 million at risk in Latin America. Figure 1 shows the distribution of Chagas disease in the Americas. This disease is prevalent only in Central and South America, particularly in Argentina, Chile, Brazil, and Bolivia. It also occurs in the southern United States, however, where more than 90,000 Latin Americans are believed to be infected. The risk of transmission in the United States is mainly by blood transfusion by this immigrant population.

A. Transmission

Chagas disease is transmitted to children and young adults less than age 20 through the bite of a bug (reduviid, subfamily Triatominae). The bug becomes infected by feeding on infected animals such as the armadillo,

opossum, raccoon, and skunks. Domestic dogs and cats also provide an extensive reduviid reservoir for infecting entire families.

The biting bug unfortunately dwells in the roofs and walls of houses. During the night the bug drops onto the sleeping individual and inflicts bites around the eyes. Infection is transferred when the trypanosomes in the animal's excrement enter the wounded skin or penetrate the conjunctiva. The protozoa multiply and then migrate through most organs of the body including the myocardium, pericardium, liver, spleen, and brain. Chagas disease is primarily transmitted through blood transfusions, and unfortunately screening of blood is financially not possible in the affected countries. The simple accomplishment of screening blood, building better homes, and screening cats and dogs would prevent the majority of infections.

II. SYMPTOMS AND SIGNS

A. Acute Phase

The bite of the bug around the eyes allows the trypanosomes to gain entry through the conjunctiva. This often results in one-sided swelling around the eye (periorbital edema) and swelling of the eyelid (Romana sign). If the entry is through the skin, a lesion called a chagoma appears. The initial lesion may go unrecognized, however, and no symptoms may appear until after more than 15 years when symptoms of chronic disease emerge. In about 10% of infected individuals acute symptoms such as muscle aches and pains, fever, sweating, and enlargement of the liver and spleen occur. If the parasitic infection involves the cardiac muscle, an acute myocarditis and heart failure may supervene causing death. Lesions may spread to involve the endocardium and stimulate the flowing blood to form a clot that may embolize. The pericardium may be involved causing pericardial effusions. Young children become more seriously ill than young adults, and in more than 10% the acute disease is fatal. Many patients recover, however, and symptoms disappear



FIGURE 1 Distribution of Chagas disease in the Americas. (From Acquatella, H. (1995). *Atlas of Heart Diseases*, Vol. 2. (Abelmann, W.H., Braunwald, E., eds.). p. 8.1–8.18, Philadelphia: W.B. Saunders.)

over 1–2 years. More than 40% of infected patients after a relatively symptom-free interval of several years reveal signs and symptoms of chronic Chagas disease.

B. Latent and Chronic Phase

Cardiac involvement is mainly due to a cardiomyopathy that manifests about 20 years after the trypanosomal infection. At this point, the heart muscle is uniformly destroyed and replaced by fibrous tissue. The weakened heart muscle is stretched, the left ventricular chamber dilates, the pumping function is severely deranged, and heart failure supervenes. Heart failure produces changes in the heart, circulation, and veins that can be detected on examination by the physician. A chest x-ray confirms dilation of the heart and presence of fluid in the spongework of the lungs and fluid within the pleural space (pleural effusions).

The main manifestation of heart failure is increasing shortness of breath on mild activity and with severe heart failure, shortness of breath occurs at rest. Heart failure describes the signs and symptoms that occur when the left or right ventricles are unable to eject an adequate amount of blood into the aorta to fulfill the needs of organs and tissues. Thus blood remains longer in the lungs and salt

and water escapes into the air sacs (the alveoli), causing oxygen lack and severe shortness of breath. In heart failure, salt and water are retained by the kidneys as a compensatory mechanism and extra fluid exudes into tissues in dependent parts of the legs causing bilateral leg edema. The legs are not waterlogged, they are brine logged (see the chapter Heart Failure).

The pathologic findings include hypertrophy and dilatation of cardiac chambers in keeping with a dilated cardiomyopathy. The left ventricle apex becomes thin and bulges into an aneurysm. Clot formation often occurs within the aneurysm and thromboembolism to other organs occurs.

The electrical bundles of the heart, particularly the right bundle branch and the anterior fascicle of the left bundle branch, are commonly involved by the inflammatory process causing the ECG to show a typical pattern of right bundle branch block and left anterior fascicular block hemiblock. The large left bundle branch is really involved.

Symptoms of cardiomyopathy include shortness of breath, chest pain, syncope, and sudden death caused by heart block due to involvement of the electrical conducting system. In many patients the left ventricle fails, but manifestations are mainly of right heart failure. Thus, the shortness of breath from left ventricular failure may diminish and signs of right heart failure may become more

prominent. These signs include fluid retention that causes swelling of the abdomen (ascites) and bilateral leg edema.

The trypanosome in Brazil often involves the esophagus, stomach, and colon resulting in a dilated esophagus (megaesophagus and megacolon). This is uncommon in Central America and Mexico because it is caused by a different strain of trypanosome.

In the acute phase of the disease, trypanosomes are found in the cardiac fibers accompanied by marked cellular infiltrate around cells that have ruptured and released the parasites. It is not unusual, however, to be unable to find parasites in the cardiac tissue at autopsy. An autoimmune mechanism is believed to explain the lack of correlation of parasitemia with disease severity. *T. cruzi* antigen is frequently found in biopsy specimens.

III. DIAGNOSTIC INVESTIGATIONS

A. Chest X-ray

The chest x-ray shows a dilated heart that increases to severe proportions as the disease progresses. The lungs may show evidence of fluid accumulation with pleural effusions, but the lung fields may be relatively clear if mainly right heart failure occurs.

B. Blood Tests

In Chagas disease the serum aldolase is usually elevated. A complement fixation test (Machado-Guerreiro test) that has high specificity and sensitivity is used to identify chronic Chagas disease. Xenodiagnosis is the preferred test in endemic areas. With this test reduviid bugs bred in the laboratory are allowed to bite the patient. The parasites are then found in the intestine of the insect proving infection in the patient.

C. Echocardiography

Echocardiography shows enlargement of all four heart chambers in Chagas patients. There is also a reduction in

the ejection fraction. On echo, the appearance of Chagas is distinctive: there is hypokinesis, poor contractility of the left ventricular posterior wall, relatively preserved intraventricular septal wall motion, and poor movement of the apical segment of the heart with dilatation and aneurysmal formation.

IV. MANAGEMENT

A. Prevention

Vector control and interruption of transmission of the parasites to humans remain crucial. In endemic areas individuals should avoid having dogs or cats in the home. Improved housing conditions, repair of walls and ceilings, and added fresh paint should deter bugs from these areas. The use of nets for sleeping should prevent bugs from falling from ceilings onto the exposed face at night.

B. Medications

Antiparasitic agents such as benzimidazole, itraconazole, and nifurtimox reduce parasitemia in the acute phase, but they do not have any effect on the autoimmune-mediated chronic form of the disease. Anticoagulants are necessary in patients with left ventricular aneurysm or thrombi detected in the ventricle and those who have sustained embolism. Arrhythmias often require treatment with antiarrhythmics such as amiodarone. This drug is used for symptomatic relief and does not appear to prolong life.

BIBLIOGRAPHY

- Apt, W., Aguilera, X., Arribada, A. et al. Treatment of chronic Chagas disease with itraconazole and allopurinol. *Am. J. Trop. Med. Hyg.*, 59:133, 1998.
- Parada, H., Carrasco, H. A., Anez, N. et al. Cardiac involvement is a constant finding in acute Chagas disease: A clinical parasitological and histopathological study. *Int. J. Cardiol.*, 60:49, 1997.
- Wynne, J., and Braunwald, E. In *Heart Disease*, sixth edition. E. Braunwald, D. P. Zipes, and P. Libby, eds. W. B. Saunders, Philadelphia, 1979, 2001.

Chelation and Heart Disease

- I. Clinical Study
- II. Perspective

therapy. Controversies have raged in the last 30 years regarding the value of chelation therapy.

GLOSSARY

angina chest pain caused by temporary lack of blood to an area of heart muscle cells usually caused by severe obstruction of the artery supplying blood to the segment of cells.

atherosclerosis same as atheroma, raised plaques on the inner wall filled with cholesterol, calcium, and other substances on the inner wall of the arteries that obstruct the lumen and the flow blood; the plaque of atheroma hardens the artery, hence the term atherosclerosis (sclerosis = hardening).

myocardial infarction death of an area of heart muscle due to blockage of a coronary artery by blood clot and atheroma; medical term for a heart attack or coronary thrombosis.

plaque of atheroma same as atherosclerotic, a plaque that juts into the lumen and obstructs the flow of blood in arteries.

OBSTRUCTION OF CORONARY ARTERIES BY cholesterol, calcium deposition, and fibrotic tissue followed by accumulation of blood particles, platelets, and finally thrombosis is the cause for angina, heart attack, heart failure, and sudden death. After more than 50 years of considerable research on the cause and prevention of obstruction to coronary arteries by plaques of atheroma, we are still a moon ride away from preventing obstruction to arteries. Chelation, a method for clearing the obstruction, is analogous to using Drano to clean obstructed pipes. Treatments cost approximately \$4000 per year and, surprisingly, during the 1980s and 1990s was used by more than half a million patients in the United States annually. It appears that in Canada approximately 8% of patients undergoing coronary angiography have tried chelation

I. CLINICAL STUDY

Study question: Does chelation therapy with EDTA impact exercise-induced ischemia or quality of life in patients with stable coronary artery disease?

Methods: A double-blind randomized clinical trial of 84 patients with stable angina (stable coronary artery disease) on the usual recommended medical therapy and significant electrocardiographic ST segment depression were studied. EDTA 40 mg/kg or placebo was administered for three hours per treatment twice weekly for 15 weeks and then once monthly for three months. Male patients represented 84% of the study group, average age 65 years, multivessel disease was present in approximately 55%, 50% of patients were asymptomatic, and 60% had significant angina.

Results: At baseline there was no difference in the time of onset of ischemia on electrocardiographic treadmill testing. After treatment there was no difference to support a beneficial effect of calcium chelation therapy with EDTA. There was no difference in exercise time to induce ischemia on the treadmill and no difference in exercise capacity or quality of life.

II. PERSPECTIVE

Knudtson et al. concluded: "physicians can now inform patients that there is no scientific evidence to support the claim that \$4000 per year for chelation therapy with EDTA is money well spent." The fact that controversial chelation therapy is still practiced indicates that we do not have treatment that provides satisfactory beneficial

effects for the majority of patients treated for obstructive coronary artery disease and that more research is required. The idea of chelation should not be abandoned. EDTA has had its day but perhaps other molecules that can dissolve plaques of atheroma should be sought.

BIBLIOGRAPHY

- Knudtson, M. L., Wyse, K. G., Galbraith, P. D. et al. Chelation therapy for ischemic heart disease. A randomized controlled trial. *JAMA*, 287:481–6, 2002.
- Merrill, L. K., Wyse, G., Galbraith, P. D., Brant, R., Hildebrand, K., Paterson, D., Richardson, D., Burkart, C., and Burgess, E. for the

Program to Assess Alternative Treatment Strategies to Achieve Cardiac Health (PATCH) Investigators. *JAMA*, 287:481–486, 2002.

ABSTRACT

Context Chelation therapy using EDTA is an unproven but widely used alternative therapy for ischemic heart disease.

Objective To determine if current EDTA protocols have a favorable impact on exercise ischemia threshold and quality of life measures in patients with stable ischemic heart disease.

Chemotherapy-Induced Heart Disease

- I. Chemotherapeutic Agents
- II. Cardiac Damage from Anthracyclines
- III. Cyclophosphamide
- IV. 5-Fluorouracil

GLOSSARY

afterload arterial impedance, restriction of blood flow delivered from the left ventricle; force against which the myocardium contracts in systole; a major determinant of wall stress.

endocardium internal lining of the heart.

heart failure a failure of the heart to pump sufficient blood from the chambers into the aorta; inadequate supply of blood reaches organs and tissues.

hypotension marked decrease in blood pressure, usually less than 95 mmHg.

ischemia temporary lack of blood and oxygen to an area of cells, for example, the heart muscle, usually due to severe obstruction of the artery supplying blood to this area of cells.

metastases distant spread of cancer to various organs.

myopericarditis specific or nonspecific infection of both the pericardium and the myocardium.

necrosis cell death.

DURING THE PAST DECADE THERE HAVE BEEN considerable advances in the use of chemotherapy for the treatment of the various cancers such as Hodgkin's and non-Hodgkin's lymphoma, acute leukemias, colorectal and lung cancer, and local tumor control particularly with breast cancer. Metastases to various organs causes untold suffering and pain. Chemotherapy is effective in many patients, but its toxic effects on the heart, particularly on the myocardium, often limit their use in patients who may need these agents the most. Most important, cardiomyopathy caused by chemotherapeutic agents causes death in a significant number of patients. Further research is required to provide new effective agents with less toxicity.

I. CHEMOTHERAPEUTIC AGENTS

It is common for chemotherapeutic agents to be associated with myocardial damage reduction in ejection fraction and heart failure.

The toxic effects of anthracyclines on the heart are well known. Doxorubicin, in a total toxic dose range of greater than 550 mg/m², causes heart failure and arrhythmias. Daunorubicin in a total toxic dose range of greater than 550 mg/m², has the same toxicity as doxorubicin. The anthracenedione mitoxantrone causes significant decrease in left ventricular ejection fraction and heart failure. Amsacrine at conventional doses causes ventricular arrhythmias. Cyclophosphamide at a dose of greater than 100–120 mg/kg over 2 days may cause heart failure, hemorrhagic myocarditis, pericarditis, and necrosis of the myocardium. Ifosfamide has similar cardiotoxic effects and can cause heart failure. 5-Fluorouracil at conventional doses may cause chest pain and coronary artery spasm that causes anginal pain and rarely, myocardial infarction. Busulfan at conventional doses may cause fibrosis of the endocardium. Cisplatin at conventional doses may cause chest pain and myocardial ischemia. Vincristine and vinblastine at conventional doses may cause myocardial infarction. Mitomycin C in conventional doses causes myocardial damage that is similar to radiation-induced injury. Interferons in conventional doses may exacerbate underlying cardiac disease. Interleukin-2 in conventional doses causes abnormal heart rhythms, hypotension, and myocardial damage.

II. CARDIAC DAMAGE FROM ANTHRACYCLINES

Anthracyclines contain an aromatic ring structure that intercalates in between DNA base pairs. The mechanism of cardiotoxicity appears to be inhibition of the function of topoisomerase II. This enzyme is critical in allowing DNA

to undergo efficient repair. Most important, these agents generate free radicals that can damage cell membranes partly by lipid peroxidation. Amsacrine and mitoxantrone produce lower quantities of free radicals and cause less cardiotoxicity and cardiomyopathy compared with the doxorubicin, daunorubicin, idarubicin, and epirubicin. Cardiac tissues possess a low ability to detoxify these free radicals because of the presence of only small amounts of catalase that converts hydrogen peroxide to water.

In addition, anthracyclines chelate iron. These anthracycline-iron complexes produce cardiac-damaging hydroxyl radicals. Research is required in this area to find molecules that may modify these toxic effects. One agent, dexrazoxane, undergoes hydrolysis to a carboxylamine that is capable of removing iron from the anthracycline-iron complex. It is partly effective in protecting the myocardium from damage.

Listed below are electrocardiographic manifestations of anthracycline cardiac damage.

1. Prolongation of the QT interval may occur in some cases following the first or subsequent doses. Thus, other drugs that may increase the QT interval should not be administered concurrently because arrhythmias may be precipitated.
2. Increased heart rate, sinus tachycardia, and abnormal heart rhythms may arise from the atrium such as supraventricular tachycardia.
3. Electrical conduction disturbances such as atrioventricular block and bundle branch block may occur.
4. ST segment elevation and T-wave changes that reflect pericarditis or myopericarditis may occur. The damage to the heart may culminate in heart failure and death during the first 2 weeks of therapy, albeit rarely.

Most of the cardiac toxic effects of anthracyclines are caused by prolonged therapy and the cumulative dose of the drug. There is loss of cardiac myocytes with increasing doses of these agents. Vacuolation of cells and myofibrillar dropout cause weakness of muscle elements that lead to dilatation of the ventricular muscle, which constitutes a chronic dilated cardiomyopathy that may appear and progress many years after cessation of anthracycline therapy.

A. Signs and Symptoms

Main symptoms of cardiotoxicity are shortness of breath and fatigue caused by cardiomyopathy that causes poor ejection of blood from the heart (ejection fraction) into the arteries. These are symptoms of heart failure. Physical signs

include edema, enlargement of the liver, and accumulation of fluid in and around the lungs, and pleural effusions. The veins in the neck may be distended with blood that the heart is unable to pump forward (indicating jugular venous pressure). The chest x-ray may show signs of heart failure. Abnormal heart rhythms are common.

There are several diagnostic tests to reveal anthracycline cardiotoxicity. Patients are usually followed with radionuclide ventriculography, which gives a good assessment of the left ventricular ejection fraction. A decrease in the ejection fraction to less than 40% is a signal for the development of heart failure. An ejection fraction below 45% indicates that myocardial damage has already taken place. Echocardiographic assessment is not as accurate as radionuclide ventriculography for determination of the ejection fraction, but it gives the best assessment over myocardial wall abnormalities and regional cardiac relaxation. These subtle abnormalities as well as the echocardiographic findings described above may be the first signals of cardiac damage.

B. Management of Cardiotoxicity

Arrhythmias are one symptom of cardiotoxicity. They are managed with administration of beta-blockers. Supraventricular tachycardia and bothersome sinus tachycardia can be controlled with atenolol, 25–50 mg once daily or metoprolol, extended-release 50 mg once daily. A major contraindication to beta-blockers is the precipitation of wheezing and severe asthmatic attacks in susceptible individuals. They are, however, safe in patients with mild chronic bronchitis (see the chapter Beta-Blockers). Patients with ejection fractions less than 45% should be commenced on an afterload reducing agent such as an ACE inhibitor: enalapril 5 to 10 mg once daily or similar dosage of another ACE inhibitor (see the chapter Angiotensin-Converting Enzyme Inhibitors/Angiotensin Receptor Blockers).

Patients with heart failure should be managed with optimal therapy with diuretics such as furosemide 20–60 mg once daily, an ACE inhibitor, digoxin, and a small dose of a beta-blocker. If heart failure persists, spironolactone should be added to the regimen (see the chapter Heart Failure). Changes in dose schedules to weekly intravenous infusions rather than a larger dose every 3 weeks appears to afford some cardioprotection.

C. Research Implications

In the prevention of cardiotoxicity, the use of liposome-encapsulated anthracyclines appears to be controversial.

Dexrazoxane is capable of accepting the iron from the anthracycline–iron complex that generates tissue-damaging hydroxyl radicals and provides some cardioprotection. However, this agent may increase the incidence of myelosuppression and has not been shown to increase disease-free survival. Its use is limited to oncologists.

Agents that require further clinical testing include coenzyme Q10, melatonin, probucol, beta-blockers, calcium antagonists, and glutathione. A transgenic mouse overexpressing the human complementary DNA for multiple drug resistance, driven by an alpha-cardiac myosin gene, has been developed. These transgenic mice appear to be resistant to anthracycline-mediated cardiac-myocyte dropout. Newer agents that can be of value to many patients who suffer from cancer worldwide are being researched and developed.

III. CYCLOPHOSPHAMIDE

Cyclophosphamide and ifosfamide high-dose therapy may cause severe cardiomyopathy and heart failure in patients undergoing stem cell transplantation. Acute myocyte necrosis, with damage to the endothelial lining of the heart, and hemorrhagic myopericarditis may occur with a 30% mortality rate. The ECG shows abnormal patterns and the chest x-ray is a good test for detecting heart failure. An echocardiogram is not a test used for the detection of heart failure, but it is useful in revealing weakness of the heart muscle, pericarditis, or pericardial effusions. Serious complications are more common in patients with pre-existing heart disease, particularly in those with left ventricular dysfunction and an ejection fraction of less than 45%.

Interferon alfa is a drug used in the management of chronic myelogenous leukemia, hairy cell leukemia, and Kaposi's sarcoma. It may cause severe dilated cardiomyopathy with symptoms and signs of heart failure that are reversible when the drug is discontinued.

Interleukin-2 is a drug that has been noted to cause hypotension, rarely myocardial infarction, noncardiogenic pulmonary edema, and kidney failure.

IV. 5-FLUOROURACIL

This is a frequently used agent and its associated cardiotoxicity may be more common than previously thought.

Cardiotoxic effects occur when the drug is administered as a continuous infusion and within 5 h of infusion. Symptoms and signs are usually reversible within a few days. 5-Fluorouracil should be discontinued when

cardiotoxicity arises and reinstatement is not advisable due to high incidence of recurrence. The overall incidence of cardiotoxicity ranges from 2 to 18% with a mortality of 2–15%. Unfortunately, there is no method to predict which patients are risk, because it has been noted that pre-existing heart disease, dose and route of administration, age, and chest radiation do not consistently correlate with associated toxicity. In a study of 1083 patients, however, those with a prior history of heart disease had a significantly increased risk (4.5 vs. 1.1%) of developing chest pain compared with patients without known heart disease (<0.01).

A. Acute Cardiovascular Effects

Chest pain often may not have a cardiac origin, but true anginal pain has been noted with the use of 5-fluorouracil, albeit rarely. Onset of pain usually occurs within hours of receiving a second or third dose but may be associated with the first dose. Anginal attacks may occur upon rechallenge with fluorouracil and, unfortunately, may not be prevented with the usual antianginal medications that include nitrates or calcium antagonists. In some patients typical crushing chest pain may occur with electrocardiographic changes that improve after discontinuation of the drug. Patients who have experienced chest discomfort with ECG changes should be administered further doses of 5-fluorouracil only if absolutely necessary, and this should be done in a cardiac unit with appropriate monitoring. The ECG may reveal no abnormalities during chest pain, yet several hours later ST segment elevation or nonspecific ST-T wave changes may be observed. Myocardial infarction, cardiogenic shock, and death have been reported, albeit rarely.

Typical episodes of variant angina may occur within hours of administration (from 2 to 5 days following dosing). Several hypotheses regarding the mechanism of this variant angina have been proposed: coronary artery spasm, endothelial cell damage with thrombus formation, increased myocardial oxygen demand, and interference of myocardial cell metabolism. Results are inconclusive. Prophylactic nitroglycerin orally or skin preparations have failed to prevent chest pain with electrocardiographic evidence of ischemia. Unfortunately, prophylaxis using verapamil, nifedipine, or diltiazem with added intravenous nitroglycerin has also failed. When adequate protective treatment is unavailable as in this scenario, recommencing therapy with this agent may be fraught with danger.

Observable ECG changes include ST segment elevation, ST depression, nonspecific ST-T wave changes, and new Q waves. These are all suggestive for myocardial infarction, T-wave inversions, and sinus tachycardia. Occasionally

arrhythmias that include atrial fibrillation, ventricular premature beats, nonsustained ventricular tachycardia, and rarely, ventricular fibrillation have been reported. Echocardiography may reveal left ventricular wall motion abnormalities, hypokinesia, and reduced ejection fraction.

BIBLIOGRAPHY

- Stone, R. M., Bridges, K. R., and Libby, P. Hematological-oncological disorders and cardiovascular disease. In *Heart Disease*, seventh edition. E. Braunwald, D. P. Zipes, and P. Libby, eds. W. B. Saunders, Philadelphia, 2005.

Cholesterol

- I. The Magnitude of the Problem
- II. Historical and Clinical Trials
- III. Causes of Hypercholesterolemia
- IV. Types of Cholesterol
- V. Blood Tests
- VI. Coronary Artery Disease Risk
- VII. Diets and Cholesterol
- VIII. Cholesterol-Lowering Drugs

GLOSSARY

angina chest pain caused by temporary lack of blood to an area of the heart muscle cells, usually caused by severe obstruction of the artery supplying blood to the segment of cells.

atheroma same as atherosclerosis, raised plaques filled with cholesterol, calcium, and other substances on the inner wall of arteries that obstruct the lumen and the flow of blood; the plaque of atheroma hardens the artery, hence the term atherosclerosis (sclerosis = hardening).

coronary heart disease obstruction of the coronary arteries with symptoms such as chest pain, angina, or heart attacks.

dyslipidemia the same as hypercholesterolemia, elevated blood cholesterol, LDL cholesterol, triglycerides, or low HDL cholesterol.

myocardial infarction death of an area of heart muscle due to blockage of a coronary artery by blood clot and atheroma, medical term for a heart attack or coronary thrombosis.

CHOLESTEROL IS A LIPID, OR FAT-LIKE SUBSTANCE, made by animal cells. The role of an elevated blood cholesterol in causing a blockage to arteries by atherosclerosis and a subsequent myocardial infarction was a controversial issue from 1900 to 1994. Advice to patients during those 90 years was often half-hearted. Until recently we were not able to put the blame firmly on cholesterol and convince physicians and patients worldwide to aggressively lower serum cholesterol levels. The key piece

of scientific evidence proving that lowering elevated blood cholesterol in humans prevents fatal or nonfatal heart attacks was missing.

I. THE MAGNITUDE OF THE PROBLEM

If cholesterol is the major cause of atheroma that obstructs the flow of blood in arteries of the heart and brain, significant morbidity and mortality from cardiovascular disease would be prevented by the aggressive lowering of total serum cholesterol and low-density lipoprotein (LDL) cholesterol. The complete occlusion of a coronary artery or cerebral artery is virtually always caused by a combination of atheromatous obstruction of the artery and subsequent rupture of the plaque of atheroma with thrombus formation on the ruptured material. Thus, the term atherothrombosis (see the chapter, Atherosclerosis/Atherothrombosis).

Atherothrombotic cardiovascular disease causes more than 14 million deaths per year worldwide in a population of about 6 billion people. This is expected to increase to more than 25 million deaths by the year 2020 in a population of about 7.4 billion people. It is estimated that worldwide interventions could prevent more than one million deaths annually. The prevention of atheroma is obviously more important to world health than the expensive production of so-called left ventricular assist devices, which are a bridge to heart transplantation.

II. HISTORICAL AND CLINICAL TRIALS

A. 1900–1983

Few physicians believed that cholesterol was a major factor in the development of atherothrombosis. Supportive evidence was based mainly on investigations in cholesterol-fed, hypercholesterolemic rabbits that showed the development and progression of atheroma formation

relative to the elevation in blood cholesterol. Anecdotal reports and small clinical studies supported this notion.

- The Seven Countries Study included more than 12,000 men from Finland, Greece, Italy, The Netherlands, Japan, the United States, and Yugoslavia. The Finns had the highest intake of saturated fat, the highest blood cholesterol levels (greater than 280 mg), and the highest number of fatal and nonfatal heart attacks, about 900 per 100,000. The Japanese, with an average blood cholesterol of 140 mg, had the lowest heart attack death rate of 102 per 100,000. The United States, with an average of 220 mg, had a heart attack death rate of 670 per 100,000. The death rate was also low in Greece and Italy. Japanese immigrants to the United States who adopt an American diet have an incidence of coronary artery disease ten times that of their countrymen in Japan.
- The Framingham epidemiologic studies contributed good evidence to support the view that a high blood cholesterol greatly increases the risk of developing coronary artery disease.
- People who have a rare, inherited genetic defect that prevents the body from getting rid of cholesterol may have blood cholesterol levels as high as 900–2000 mg (23–50 mmol/L) from early childhood. These patients develop cholesterol-containing lumps and bumps, especially on the knees, elbows, and tendons of the wrists and the Achilles tendon. These individuals may have a heart attack from the age of 1 to 10. Fortunately the condition, homozygous type II hyperlipoproteinemia, only occurs in one per million.

Because of these studies, more than 60% of physicians believed that an elevated serum cholesterol was a major factor, but proof from randomized clinical trials was still lacking.

B. 1984

The Lipid Research Clinics Program reported the results of a successful trial in the United States over a period of 10 years at a cost of \$150 million. The trial showed that a reduction in blood cholesterol resulted in a small but significant reduction in fatal and nonfatal heart attacks.

This study was randomized and scrupulously conducted in many centers in the United States and in two centers in Canada. More than 480,000 men aged 35–59 were screened to find subjects who had a cholesterol level greater than 265 mg (6.9 mmol), but were otherwise healthy and had no evidence of heart disease or hypertension. The 3806 men found suitable for the trial were asked to follow

a cholesterol-lowering diet. A random group of half the men was given a drug to lower cholesterol (cholestyramine, 24 g daily); the other half was given an identical-looking but nonmedicinal preparation (placebo). The cholesterol-lowering drug caused an 8% lowering of the blood cholesterol. After follow up for an average of 7.4 years, there were 187 fatal or nonfatal heart attacks in the control group and 155 in the drug-treated group. Unfortunately, cholestyramine is a powder that is mixed with fruit juice and is unpleasant to taste. Patients do not comply with taking it two or three times daily, and it is not surprising that the reduction in cholesterol was 8% rather than the expected 25%. Nevertheless, the study showed that lowering of cholesterol by a special drug reduces the occurrence of heart attack. Thus a reduction of blood cholesterol by diet should have a similar good effect, but a strict diet only reduces total serum cholesterol from 7 to 10%.

C. 1994

The Hallmark Scandinavian Simvastatin Survival Study (4S) was undertaken in 1994 (see Table 1).

Methods: This large multicenter study randomized 4444 patients with mean cholesterol levels of 261 mg/dl (6.7 mmol/L) and LDL cholesterol levels of 172 mg/dl (4.87 mmol/L) to treatment with either simvastatin 20 mg or a matching placebo. The patients had angina or previous myocardial infarction. The therapeutic goal of 4S was to reduce total cholesterol to approximately 200 mg/dl; 37% of individuals required 40 mg per day to achieve this goal.

Results: Total cholesterol was reduced 25% and LDL concentrations were reduced 35%. HDL levels increased 8%. At 5.4 years median follow up there was a highly statistically significant decrease in total mortality rate of 30%. There were 256 (12%) deaths in the placebo group versus 182 (8%) in the simvastatin group ($P=0.0003$). The placebo group had 189 coronary deaths compared with 111 in the simvastatin group, a 42% reduction in the risk of coronary deaths.

Also in 1994 the Multicenter Anti-Atheroma Study (MAAS) was undertaken. This was a study of 381 patients with coronary artery disease treated with 20 mg of simvastatin for four years. Results showed a decrease in new obstructions in coronary arteries, and fewer treated patients required angioplasty or surgery.

D. 1995

In 1995 the West of Scotland Coronary Prevention Study trial randomly assigned 6595 apparently healthy Scottish

men 45–64 years of age with a mean plasma cholesterol level of 272 ± 23 mg/dl (7.0 ± 0.6 mmol/L) to receive the pravastatin 40 mg or placebo. After 4.9 years follow up total mortality was not significantly decreased: deaths from any cause were 135 in the placebo group and 106 in the treated group ($P=0.051$, nonsignificant). Deaths from all cardiovascular causes were 73 in the placebo and 50 in the pravastatin group ($P=0.033$). There was a significant decrease in nonfatal myocardial infarction (MI), however, with 204 nonfatal MIs in the placebo group and 143 in the treated group ($P=0.001$).

Thus, lowering elevated cholesterol in healthy men with elevated serum cholesterol in the range 250–300 mg/dl was not shown to decrease total mortality or total cardiovascular deaths in this trial. Treatment decreased total cholesterol and LDL cholesterol by 20 and 26%, respectively, compared with placebo. It is possible that more than a 33% decrease in the levels are required to show a benefit. HDL cholesterol was increased by 5% in the treated group, and this had no effect on mortality. An increase in HDL cholesterol greater than 10% should be the goal, but this needs further testing in clinical trials.

E. 1996

The Cholesterol and Recurrent Events (CARE) trial randomized 4159 patients with MI and angina to 40 mg of pravastatin treatment or placebo with a mean serum cholesterol level of 209 ± 17 and LDL cholesterol 139 ± 15 . After follow up of 5 years there were no significant differences in overall mortality or mortality from noncardiovascular causes. Yet, this study is described by some experts as a landmark study. The number of fatal MIs was 38 in the placebo group versus 24 in the treated group ($p=0.07$, nonsignificant). There was a modestly significant reduction in the number of coronary bypass surgeries required in the pravastatin group compared to the placebo. Breast cancer occurred in 12 of the 290 women treated with pravastatin and one case of cancer occurred in the control group ($P=0.002$).

F. 1988

In 1988 the Long-Term Intervention with Pravastatin in Ischemic Disease (LIPID) study group was undertaken.

Methods: This randomized clinical trial compared the effects of pravastatin 40 mg with those on placebo in 9014 patients 31–75 years of age. Patients had a history of MI or unstable angina and mean cholesterol level of 218 mg/dl (6.1 mmol/L) and median LDL cholesterol level of 150 mg/dl.

Results Over a mean follow-up period of 6.1 years overall mortality was 14.1% in the placebo group (633 deaths) and 11% in the pravastatin group (498 deaths; $P < 0.001$). Deaths from coronary artery disease occurred in 8.3% in the placebo group and 6.4% in the pravastatin group ($P < 0.001$). The trial randomized 1216 women and cancers including breast cancer were similar in both groups.

This significant decrease in overall mortality and cardiovascular deaths in patients with severe coronary artery disease and mean cholesterol levels representative of the population of patients at risk for coronary artery disease events confirms the beneficial effects observed in the 4S study. It is important to recognize that most patients with coronary artery disease have cholesterol levels that are not markedly elevated with a mean of about 225 mg/dl (5.8 mmol/L).

A strict, low-saturated-fat diet that will lower blood cholesterol by 10% percent is feasible, but it may also lower the good high-density lipoprotein (HDL) cholesterol. Whereas strict dieting can decrease total cholesterol 7–10%, the statin drugs (HMG-CoA reductase inhibitors) have been documented in the clinical trials outlined above (4S, CARE, LIPID) and in more recent trials to decrease total cholesterol and LDL (bad) cholesterol from 20–50%. It requires this aggressive lowering of total cholesterol and LDL cholesterol to achieve a reduction of atheroma development and its complications.

About 20% of the population have all the luck. They can eat a high-cholesterol, high-saturated-fat diet and violate all dietary rules, yet never get significant coronary heart disease and live beyond 79.

III. CAUSES OF HYPERCHOLESTEROLEMIA

A. Familial Hypercholesterolemia

This is a primary genetic abnormality. In very rare cases, marked elevation of cholesterol (800–1500 mg/dl) is caused by a genetic defect. A receptor on the surface of cells (LDL receptors) removes LDL cholesterol from the blood. In this disorder there is decreased production or function of the LDL receptor. This autosomal disorder may involve abnormalities in the synthesis, transport, or clustering of the LDL receptor.

Homozygous familial hypercholesterolemia fortunately is rare and occurs in approximately one per million individuals in the United States. These patients have no functioning LDL receptors and have markedly elevated LDL cholesterol as high as 1200 mg/dl (31 mmol/L) and extensive coronary and peripheral atherosclerosis.

Acute MI may occur within the first one to two years of childhood.

Heterozygotes have a reduction of 50% of the circulating LDL receptors and may have serum cholesterol levels in the range of 300–800 mg/dl and manifest coronary artery atherothrombosis, peripheral vascular disease, or atheromatous obstruction to the abdominal aorta in the third or fourth decade. Racial differences may determine the number of LDL receptors, and thus the ability to remove LDL cholesterol gradually from the bloodstream is affected.

Familial combined hyperlipidemia is a common condition that occurs in more than 1% of the North American population. This disorder may cause elevation of total cholesterol or triglycerides or both.

B. Polygenic Hypercholesterolemia

In this condition there is a genetic predisposition and dietary factors. In susceptible individuals with a decreased number of LDL receptors, high saturated fat and cholesterol intake causes substantial elevation of serum cholesterol with levels in range of 260–320 mg/dl (6.5–8.3 mmol/L). Approximately 3% of the population in the United States appears to be affected. Although elevation in total cholesterol is less severe than in heterozygous familial hypercholesterolemia, the elevation of total and LDL cholesterol increases risk for coronary artery disease and drug therapy with statins is advisable.

C. Other Causes for Hypercholesterolemia

Type 2 diabetes occurs in approximately 7% of the North American population and nearly all of these individuals have some form of dyslipidemia. Their serum cholesterol is usually in the range of 240–290 mg/dl (6.2–7.5 mmol/L). Hypothyroidism is a relatively common condition that decreases the metabolism with increases in serum cholesterol in the range of 240–320 mg/dl.

Renal disease can also affect cholesterol levels. A form of glomerulonephritis causes marked loss of protein in the urine, diffuse edema, and hypercholesterolemia. Biliary cirrhosis with its prolonged obstructive jaundice causes marked elevation in serum cholesterol. Other causes include pancreatitis, monoclonal gammopathy, and porphyria.

IV. TYPES OF CHOLESTEROL

Cholesterol is a member of a class of naturally occurring compounds called sterols. It is an essential part of the

fatty sheath that insulates nerves and the outer membrane of all animal cells, and is a component of chemicals that include steroids (cortisone) and sex hormones such as androgens and estrogens. Cholesterol acts as a precursor of bile acids and occurs in high concentrations in the brain, nerves, and adrenal glands; cholesterol concentration is greater than 3 g per 100 g in the brain. Body cells satisfy their cholesterol requirements for maintenance and growth by intracellular synthesis of cholesterol and the receptor-mediated uptake from the external medium of cholesterol-rich LDL particles.

Dietary cholesterol is absorbed from the jejunum in an unesterified form. Within the small intestine cholesterol is esterified with fatty acids and incorporated into the triglyceride core of chylomicrons that are secreted into the intestinal lymphatics and reach the blood circulation. Within the bloodstream chylomicrons are converted into remnant particles through the action of lipoprotein lipase. Triglycerides are liberated and virtually all the cholesterol particles are carried to the liver via the portal vein.

Less than half the cholesterol in the diet is absorbed. It is interesting that after many years intensive drug research, ezetimibe, the newest agent, has been shown to localize in the distal and at the brush border cells of the small intestine and inhibit cholesterol absorption. This drug is, therefore, an important addition to our therapeutic armamentarium because it can be combined safely with the powerful acting statins that interfere with the manufacture of cholesterol in the liver.

The human body contains approximately 1 g of cholesterol per kilogram body weight. About 1 g of cholesterol is lost from the body by the conversion to bile acids and steroid hormones. This loss is balanced by endogenous synthesis from saturated fats and fecal excretion of unabsorbed dietary cholesterol.

Some of the cholesterol in blood is derived from the food you eat, but the major part, greater than 70%, is manufactured in the liver, mainly from saturated fats. Thus, if we had no cholesterol in the diet, the liver would manufacture more cholesterol to compensate. Some excess cholesterol is excreted in the bile. Cholesterol is present only in foods of animal origin, in particular, eggs, milk, butter, cheese and meats, and a very high concentration is present in gland meats, such as liver, brain, kidney, heart, and sweetbreads. Plant-based foods such as potatoes, wheat, rice, vegetables, fruits, grains, and beans contain no cholesterol.

In order to understand the changes that may be required in your diet, it is important to learn the difference between the types of cholesterol: total cholesterol, LDL cholesterol, and HDL cholesterol. Individuals should become familiar with the different types of fats in foods

such as triglycerides, saturated fats, monounsaturated fats, and polyunsaturated fats (see Section VII).

A. Total Cholesterol

Cholesterol is a fat (lipid) that is insoluble in water. It is absorbed by the intestine or released from the liver into the bloodstream. Cholesterol does not circulate freely in solution but is attached to a protein carrier, forming a molecule called a lipoprotein. Lipoproteins vary in size and density; the smaller the size, the higher the density. Cholesterol may be transported in a low-density lipoprotein; thus the term “low-density lipoprotein (LDL) cholesterol.” There is also a high-density lipoprotein (HDL) cholesterol (see the chapter Dyslipidemia).

When a doctor states that your cholesterol is 250 mg (6.5 mmol), he is giving you the total amount of cholesterol in your blood, which includes LDL and HDL cholesterol. The total figure is not broken down unless specifically requested by the doctor. The values given in milligrams are the amount in each 100 ml of blood or number of millimoles in one liter of blood.

B. Low-Density Lipoprotein (Bad) Cholesterol

The low-density lipoprotein is small and contains most of the cholesterol that is transported to cells. About 75% of the blood cholesterol is carried as LDL cholesterol. The LDL cholesterol particle is the one responsible for atheroma formation and progression. The higher the level of LDL cholesterol in the blood, the greater the risk of coronary heart disease; thus the term “bad” cholesterol.

Oxidation of LDL cholesterol is believed to be an important process in the formation and progression of atheroma. It appears that oxidative modification of LDL causes an increase in foam cell formation and increased rates of LDL accumulation within developing atheromatous plaques. In addition, oxidized LDL appears to have direct cytotoxic effects on the endothelium of arteries at the site of injury.

Oxidative stress causes oxidation of LDL cholesterol. Oxidative stress results from the production of reactive oxygen species, superoxide anion, and hydrogen peroxide molecules that cause oxidative damage and trigger intracellular signaling cascades. The constituents of the atheroma plaque produce and use reactive oxygen species. LDL cholesterol reduction appears to reduce the production of deleterious reactive oxygen species.

This author believes that it is unlikely that LDL particles cause direct injury to normal healthy endothelium, because the same blood level of LDL cholesterol is present

in veins that virtually never develop atheroma except when they are exposed to high blood pressure, such as in severe pulmonary hypertension. It is more likely that shear stress caused by turbulence of blood at particular focal points in arteries, particularly at branching areas, and other factors cause endothelial injury; LDL particles then just partake in the orchestration of accelerated atheromatous plaque growth. Increased blood pressure appears to promote atherogenesis through the mechanical effects of pulsatile blood flow (see the chapter Atherosclerosis/Atheroma).

A plasma level of LDL cholesterol greater than 160 mg/dl is associated with a high risk for coronary artery disease events in susceptible individuals and levels less than 100 mg/dl confer a low risk. When an individual is documented as having very-high-risk LDL cholesterol levels (>200 mg/dl) associated with premature coronary artery disease, all available first-degree relatives should be tested.

C. High-Density Lipoprotein (Good) Cholesterol

Much interest has been focused on HDL cholesterol, so-called because it is very small in size and very high in density. HDL cholesterol is believed to carry cholesterol away from body cells such as the lining of arteries helping to keep the artery wall clean; thus the term “good” cholesterol.

As discussed earlier most heart attacks occur in individuals with total cholesterol levels between 210 and 240 mg/dl (5.5 and 6.2 mmol/L), and more than 50% of adult Americans have cholesterol levels in this range. In these individuals with borderline high blood cholesterol, a low level of HDL cholesterol further increases the risk for coronary artery disease. Figure 1 shows the incidence of coronary heart disease in four years by HDL cholesterol and total plasma cholesterol level for men and women older than 49 and free of cardiovascular disease.

The HDL system comprises a variety of small lipoproteins smaller than LDL, but both HDL and LDL particles contain mostly cholesteryl ester. Virtually all HDL particles contain apoA-1 as their major apolipoprotein and the particles vary a little in size; the largest particles is HDL 2 and the predominant smaller particle HDL 3.

I. Metabolism

The many steps involved in HDL metabolism are not fully understood. Small HDL 3 particles accumulate cholesteryl ester and expand to HDL 2; an important step is further transformation by interaction with cholesteryl ester

transfer protein (CETP). At each step of the HDL metabolic cycle some apoA-1 is lost. High levels of CETP turn up the cycle at a high rate and this diminishes the total pool size of HDL that is manifested as a lowered HDL cholesterol level.

It appears that CETP is an important enzyme involved in HDL biology. Inhibiting this key enzyme that modulates HDL can raise HDL levels. Vaccines and cardioactive agents that may increase HDL levels significantly are being investigated, and there is great hope that major increases in HDL cholesterol would cause significant protection from atherothrombosis and its serious impact on morbidity and mortality worldwide.

2. Effect on Atherosclerosis

Several epidemiologic studies indicate an inverse relationship between HDL cholesterol levels and risk for coronary artery disease (see Fig. 1). A low HDL cholesterol level greater than 35 mg/dl (0.9 mmol/L) has been designated as a major risk factor for coronary artery disease. It is stated that every 1% increase in HDL cholesterol decreases coronary artery disease risk by about 2%, and each 1% reduction in total cholesterol should produce a 2% reduction in coronary artery disease risk. In Finland where HDL blood cholesterol levels are among the highest in the world, the cardiovascular death rate is the highest of all European countries (see the chapter Heart Attacks).

Some scientists suggest that HDL promotes reverse cholesterol transport, that is, the removal of cholesterol from tissues including removal of unesterified cholesterol in atheromatous plaques so that it can be transported to the liver and excreted. But proof is required. Most important, HDL is believed to prevent LDL from oxidation and aggregation and thus protect against formation and progression of atheroma. This important area requires further intensive investigation for clarification.

3. Variability of HDL Levels

About 25% of blood cholesterol is carried as HDL cholesterol. People with high levels of HDL cholesterol, greater than 60 mg (1.6 mmol), appear to live longer and have less coronary artery disease. People with levels less than 31 mg (0.8 mmol) have an increased risk of coronary artery disease. It is not clear why some people should have high values and others very low. It appears that about half of the variation in HDL levels in the general population is explained by genetic factors. Fortunately not all individuals with low HDL levels get heart attacks.

Nongenetic factors that are known to be associated with low levels of HDL are diabetes, obesity, smoking, and lack of exercise.

Most females and males prior to puberty have about the same cholesterol levels. Boys, however, at puberty have about a 20% drop in HDL and a rise in LDL cholesterol. The decrease in HDL cholesterol may be due to an increase in androgens. In men the HDL level stays fairly constant up to age 55, then starts to rise between 55–65. It is possible that this rise might be due to a decrease of androgens, which occurs during the male climacteric period. In women there is a gradual rise in HDL cholesterol from age 25 onward. Women are believed to be protected until post menopause by this increase in HDL and by their hormonal status. Why women are protected from coronary heart disease until menopause and yet not protected from strokes is not easily explained, especially if atherosclerosis is the basis of both diseases.

There is a relationship between HDL cholesterol levels and population groups, foods, alcohol, exercise, and drugs.

a. Population Groups

The Japanese and Inuit men and the black population in England, Jamaica, South Africa, and the United States appear to have higher HDL cholesterol levels than whites. The exact reason for this finding is unknown. It may be due to a combination of genetic or environmental factors and diet. In Finland HDL cholesterol blood levels are among the highest in the world, but it is not cardioprotective. Thus there are discrepancies that must be resolved by intensive investigative research.

b. Foods and Beverages

A low-saturated-fat, low-cholesterol diet modified to be acceptable to patients may cause a small fall in HDL cholesterol levels. A very low-saturated-fat diet causes a significant reduction in HDL cholesterol. A high-carbohydrate diet produces a mild fall in HDL cholesterol. A vegetarian diet may cause a slight decrease in HDL and this may be due to an increased carbohydrate intake.

A diet rich in the saturated fats increases HDL levels. The intake of saturated fats is very high in Finland where levels of HDL cholesterol are believed to be the highest in the world. This fact is stressed because despite the high blood HDL cholesterol, the highest cardiovascular disease rates in Europe exists in Finland (greater than 800 deaths per 100,000 for men and 500 deaths per 100,000 for women). Northern Ireland and Scotland hold the second and third spots. The United States and the UK have slightly lower rates. The rates per 100,000 men (and women) in France, Spain, Portugal, Russia, Ukraine, and Slovenia are approximately 330, (120), 400, (180),

600 (305), 1340 (657), 1490 (830), and 700 (310), respectively.

The French death rate from cardiovascular disease is the lowest in developed countries. The exact reason for this remains unclear. The French consumption of red wine which increases HDL cholesterol is believed to play a cardioprotective role. The mechanism by which alcohol increases HDL blood levels is unclear, but high consumption of alcohol may inhibit the activities of CETP and hepatic triglyceride lipase. If this action proves to be correct, then blood HDL cholesterol levels should increase. There are, however, factors other than increased HDL that are produced by alcohol consumption and appear to be cardioprotective and vascular protective. Products present in French red wines that are not present in German red wines have been shown to produce beneficial vascular effects (see the chapter Alcohol and the Heart).

c. Exercise

Daily moderate exercise such as long-distance running (2–3 miles) can increase HDL levels approximately 5–12% (2–4 mg/dl). Strenuous and vigorous aerobic exercise can cause a 15–20% increase (6–8 mg/dl), but it is difficult for many to sustain a vigorous aerobic exercise program for more than 10 years. Often when this is performed from age 20 to 35 it is relinquished from age 45 onward, the time it is most needed. It is unfortunate that mild-to-moderate exercise five times weekly to produce the training effect (cardiovascular fitness) may increase HDL levels only 1–3 mg.

No one has documented that a rise in HDL cholesterol from low levels of less than 34 mg/dl to high levels of greater than 45 mg/dl and sustained for greater than 5 years reduces cardiovascular risk. Jogging one to two miles daily or every other day will produce the training effect, but appears to have a little or an inconsistent effect on HDL levels. A randomized clinical trial of exercise induced an increase in HDL-C and its protective effect was not seen. Thus we await randomized clinical trials of drugs that increase HDL significantly.

d. Drugs

There are a few drugs that alter HDL levels slightly. Niacin causes a mild increase (5–10%) in HDL levels, but the drug causes many adverse effects. The beta-adrenergic blocking agents may cause mild reduction in HDL cholesterol from 1 to 7%, but these agents are known to decrease cardiac mortality and morbidity because of cardioprotective mechanisms. Pharmaceutical companies are busy developing HDL-increasing compounds, but they

will require several years of testing, especially with regards to safety.

e. Obesity

A body mass index (BMI equals the weight in kilograms divided by the square of the height in meters) of 25–30 is considered overweight and a BMI of greater than 30 is obese. More than 50% of Americans are graded as overweight with a BMI greater than 25, and about 18 % are obese. The prevalence of obesity is the same in Australia and New Zealand. Obesity among children is also on the rise. Obesity causes insulin resistance, an increase in triglycerides on fasting glucose, a lowered HDL cholesterol, and an increase in blood pressure. Abdominal obesity, waist circumference greater than 40 inches (102 cm) in men and 35 inches in women is more highly correlated with the metabolic risk factors than an elevated BMI.

Obese individuals have been noted to have HDL cholesterol levels that are 5–10 mg/dl lower and triglyceride levels 35–110 mg/dl higher than subjects who are lean. The Framingham study indicates that for every 10-lb. weight gain, the total cholesterol level increases 7 mg/dl in men and 5 mg/dl in women.

f. Diabetes

Virtually all type 2 diabetics have dyslipidemia manifested by mild-to-moderate elevation in serum cholesterol (230–280 mg/dl), elevated triglycerides (300–500 mg/dl), and a low HDL cholesterol (<39 mg/dl). Most diabetics die from coronary artery disease. It is believed that increased HDL levels may be cardioprotective, but randomized controlled trials are lacking. Reportedly, relatively high serum HDL levels in insulin-treated diabetics failed to protect against atheroma and development of coronary artery disease. No one is certain that raising HDL cholesterol levels or the apoprotein concentration reduces the risk of atherosclerotic coronary artery disease, and we should not shift the pendulum from the management of LDL cholesterol to the management of HDL until adequate proof is available.

g. Cigarette Smoking

Long-term cigarette smoking may enhance the oxidation of LDL cholesterol and reduce blood HDL cholesterol. Smoking also appears to impair endothelium-dependent coronary arteries and vasodilatation. It also appears to affect atherosclerosis via several mechanisms, but sound experimental proof is lacking.

h. Clinical Trials

The Veterans Affairs Cooperative studies program High-Density Lipoprotein Cholesterol Intervention trial (VA-HIT) studied individuals with atherosclerotic disease. Subjects had a low HDL cholesterol level of 32 mg/dl (0.82 mmol/L) associated with a low LDL cholesterol of 111 mg/dl (2.8 mmol/L), total cholesterol 175 mg per dl (4.5 mmol/L), and triglycerides 161 mg/dl (1.8 mmol/L). Then 1267 patients were randomized to placebo and 1264 were randomized to gemfibrozil. Mean age was 64 years, the mean BMI was 29, and participants were characterized by abdominal obesity.

At five-year follow up there were 219 coronary artery disease deaths and nonfatal MIs in the gemfibrozil group compared to 274 events in the placebo group, a relative risk reduction of 22%, an absolute risk reduction of 4.2% in favor of the active treatment group ($P=0.006$). The important total mortality was not reported. The benefit of the VA-HIT study was associated with a minimal increase in HDL cholesterol of only 7.5%. Total cholesterol decreased by 2.8% and triglycerides decreased by 24.5%.

In a similar study of 10,000 patients with major types of dyslipidemia, micronized fenofibrate 200 mg administered for 12 weeks reduced total cholesterol 20%, LDL by 25%, triglycerides by 28%, and increased HDL by 23%. The LDL/HDL ratio was lowered from a mean of 5.3 at baseline to 3.2 after 12 weeks of treatment.

D. Very-Low-Density Lipoprotein

The very-low-density lipoprotein (VLDL) is very large and low in density. It transports triglycerides, which are used mainly as a fuel; for example, in exercising muscle. The evidence linking elevated blood triglyceride levels with coronary heart disease is very weak and unclear. Thus, an elevated blood triglyceride level alone is not of importance. Weight reduction or cessation of alcohol intake always causes a marked reduction in triglyceride levels but does not alter LDL cholesterol levels.

V. BLOOD TESTS

A. Total Cholesterol

What is a normal blood cholesterol, and when does the level produce a risk of coronary heart disease? Blood cholesterol is not necessarily very high, that is, greater than 265 mg (6.9 mmol), in those who have heart attacks. In

fact, most heart attacks occur in individuals with blood cholesterol around the average of 220–250 mg (5.7–6.5 mmol). In the LIPID study described above, only 3806 men with a blood cholesterol greater than 265 mg could be found from a screening of 480,000. The remainder had cholesterol levels of less than 265 mg and most likely in the range of 200 to 250 mg.

Between 1970 and 1989, laboratories in North America reported a normal cholesterol as between 150 (3.9 mmol) and 250 (6.5 mmol). But it is now established that individuals with so-called normal cholesterol in the range of 220–250 are at increased risk, and heart attacks are common in individuals with such levels. A blood cholesterol of 220–250 mg (5.7–6.5 mmol) is considered high by world standards. Most doctors now talk about an optimal safe total cholesterol level of less than 190 mg/dl (4.9 mmol/l) or LDL less than 120 mg (3 mmol). Heart attacks are uncommon in individuals with a cholesterol level less than 160 mg (4.2 mmol).

If we treat patients with a cholesterol level greater than 250 mg (6.5 mmol), we will be excluding more than 80% of the population who are at high risk for coronary heart disease. To reiterate, most heart attacks in North America occur in people with blood cholesterol between 220 and 260 mg. Individuals with a blood cholesterol less than 180 mg (4.7 mmol) obviously deal with cholesterol by their own natural process. They are among the fortunate; no dietary modification is necessary, and blood cholesterol only needs to be rechecked about every five years.

The blood cholesterol measurement gives the total blood cholesterol, that is, LDL cholesterol plus HDL cholesterol. Food eaten within hours does not have an immediate effect on total blood cholesterol and HDL cholesterol measurements, so fasting is not necessary for this test. Triglyceride level is not an independent risk factor and therefore widespread screening for elevated triglycerides is not warranted. It is also an expensive investigation. If your doctor thinks that triglyceride determination is necessary, you must fast for 14 h before blood is taken. Blood tests for glucose, diabetes, and triglycerides are the only tests for which it is necessary to fast for 12–14 h before the test.

B. Blood LDL Cholesterol Levels

Determination of LDL cholesterol is not done routinely, because it is a difficult, time-consuming, and expensive technique. It must be done fasting because it is calculated by a formula that requires a triglyceride blood level, which must be done after fasting 12 hours. The

formula for calculating the blood LDL cholesterol level is as follows:

$$\begin{aligned} &\text{LDL cholesterol} \\ &= \text{total cholesterol} - \text{HDL cholesterol} \\ &\quad - (\text{triglyceride divided by } 5) \\ &= \text{mg/dl}; \text{ for the value in mmol/L divide by } 2 \end{aligned}$$

This formula does not apply if the triglycerides exceed 250 mg/dl.

In individuals age 15–75 optimal LDL cholesterol levels are less than 115 mg/dl (3 mmol/L). In North America, the UK, and Europe the vast majority of individuals have an LDL cholesterol in the range of 130–200 mg/dl (3.4–5.2 mmol/L). In patients with coronary heart disease, the level of LDL is of paramount importance and should be maintained at less than 100 mg/dl (2.6 mmol).

C. HDL Cholesterol Blood Level

Blood testing for HDL cholesterol levels can be done in the nonfasting state. Levels less than 35 mg/dl (0.9 mmol/L) are considered low and less than 27 mg/dl (0.7 mmol/L) is considered unacceptably low. Levels greater than 54 mg/dl (1.4 mmol/L) are considered optimal.

VI. CORONARY ARTERY DISEASE RISK

A. Based on LDL Cholesterol

A high LDL cholesterol level is considered the most important major risk factor for coronary artery disease. The relationship between LDL cholesterol and coronary artery disease risk is continuous over a broad range of blood levels from low to high (110 mg/dl to greater than 190 mg/dl) and LDL cholesterol is the primary target of therapy.

Patients with established coronary artery disease are considered to have a 10-year risk greater than 20%. It is expected that more than 20% of such individuals will develop a recurrent coronary artery disease event within 10 years. In these individuals LDL cholesterol levels greater than 130 mg/dl greatly increase the risk. Most national guidelines state that in patients with proven coronary artery disease or CAD risk equivalent, particularly diabetes, drug treatment is strongly indicated to maintain the level to less than 100 mg/dl (2.6 mmol/L) (see Table 2). This author advises a level less than 80 mg/dl (2 mmol/dl).

Individuals without coronary artery disease or evidence of cardiovascular disease should be assigned a risk based on the following:

1. Their levels of LDL cholesterol: risk is increased if the LDL-C is >190 mg/dl, and the goal should be <130 mg/dl (3.5 mmol/L)
2. Presence of diabetes risk score of >20 with a goal LDL <100 mg/dl
3. Age
4. Family history of premature coronary heart disease
5. HDL cholesterol level
6. Smoking
7. The presence or absence of hypertension

B. Estimated 10-Year Risk for Men and Women/the Framingham Point Scores

The National Cholesterol Education Program (NCEP) expert panel on detection evaluation and treatment of high blood cholesterol in adults (Adult Treatment Panel III) defines categories of risk that modify LDL cholesterol goals:

- The presence of coronary heart disease: LDL goal <100 mg/dl (the author set this goal at <80 mg/dl, 2 mmol/L)
- Individuals with coronary heart disease risk equivalents: Other forms of atherosclerotic disease such as carotid artery disease and peripheral artery disease, abdominal aortic aneurysm, diabetes, and multiple risk factors that confer a 10-year risk for coronary heart disease greater than 20% (see Table 3: the LDL goal is set at less than 100 mg/dl)
- The presence of two or more of the following risks factors: Cigarette smoking, hypertension (blood pressure greater than 140/90 mmHg or on hypertensive medications), HDL cholesterol less than 40 mg/dl, family history of premature coronary heart disease (in male first degree relative less than 55 years old and female less than 65 years old), age (men greater than 45; women greater than 55); the LDL cholesterol goal is set at less than 130 mg/dl
- 0–1 risk factor: LDL goal set at less than 160 mg/dl

Table 3 gives the estimate of 10-year risk for men and women with the Framingham point scores of a serum cholesterol of 240–279 mg/dl. A subject age 20–39 scores 9 points and a smoker 8 points. This indicates that smoking carries as great a risk as a cholesterol of 270 mg/dl. This makes little sense and indicates that the point scores require some modification.

The total cholesterol is used by the NCEP to determine 10-year risk assessment because of a larger and more robust Framingham database for total cholesterol than for LDL cholesterol. Nonetheless, the executive summary states that the LDL cholesterol is the primary target of therapy.

C. Based on the Total Cholesterol to HDL Cholesterol Ratio

The total cholesterol to HDL cholesterol ratio is used to indicate risk. An individual with a total cholesterol of 220 mg/dl (5.7 mmol/L) and HDL cholesterol of 46 mg/dl (1.2 mmol/L) has a ratio of 4.7, the average risk for coronary heart disease. This ratio is not recommended by the author because it does not give a true estimate of risk. A 50-year-old male with a serum cholesterol of 220 mg/dl, with a strong family history of heart disease occurring before age 55, is at high risk. The same individual with a ratio of 4.7 but with diabetes is also at high risk for coronary artery disease events.

The total cholesterol to HDL ratio risk for coronary heart disease is as follows:

- <3.5 = below average risk
- 3.5–5 = average risk
- 5–10 = above average risk
- >10 = much above average risk

The NCEP Adult Treatment Panel III strongly advocates the concept of global risk assessment along with the focus on LDL cholesterol as the primary target of therapy. The panel does not mention total to HDL cholesterol ratio in their 2001 guidelines. The global risk assessment is essential for identifying patients who will most benefit from risk factor modification and drug therapy. This statement does not underestimate the potential cardioprotective value of high HDL cholesterol levels exceeding 50 mg/dl. Adverse outcomes appear to be associated with HDL cholesterol levels less than 30 mg/dl (0.8 mmol/L), but clinical proof from randomized trials is required to clarify the dangers of very low HDL cholesterol levels.

VII. DIETS AND CHOLESTEROL

A. Saturated Fats and Cholesterol

All animal fat is saturated and solid at normal room temperatures. The degree of hydrogenation of a fat determines how solid and saturated it is. Saturated fats are broken down in the body and increase blood cholesterol. Therefore, the most effective dietary method of

lowering blood cholesterol is to reduce intake of saturated fats. High-cholesterol foods are few, therefore, we do not use the term low-cholesterol diet.

Vegetable fats are unsaturated and almost all are liquid at room temperatures. There are three vegetable oils that should be avoided: coconut, palm, and peanut. Coconut oil contains a high amount of saturated fat and is used for cooking in several countries. It is also used in North America in nondairy cream substitutes, for example, coffee cream. Palm oil contains significant amounts of saturated fat, and peanut oil, though mainly unsaturated, has certain fatty acids that produce plaques of atheroma in animals. The only vegetable that contains a little saturated fat is the avocado; therefore, low-cholesterol, low-fat diets often recommend that you avoid avocados. You will note from Table 1, however, that although a large avocado contains a significant amount of fat, only a little of it is saturated, and no cholesterol is present. Therefore, one avocado a week is an excellent food, especially if a high potassium intake is required.

B. Polyunsaturates and Linolenic Acid

The replacement of some saturated fats in the diet by polyunsaturated, monounsaturated, and other unsaturated fats found in abundance in vegetable oil reduces blood LDL cholesterol. The saturated and polyunsaturated fat contents of commonly used foods are given in Table 1.

Oils recommended for the preparation of meals include canola, olive, and soybean because they contain alpha-linolenic acid, very low cholesterol levels, and a minimum of saturated fat. For example, “cholesterol-free” canola oil contains 6% saturates and will produce a small amount of cholesterol in the body. Not all vegetable oils claim to be cholesterol free but contain significant saturated fats. Because vegetable margarines contain a small amount of saturated fat and hydrogenation remains controversial, they should be used in moderation (see the chapter Diets and Heart Disease). Some products may have palm or coconut oil added to enhance hardening; these two oils are not recommended (see Table 4). Olive oil is recommended for salads, but olive oil margarines may contain palm oil to enhance hardening so read labels carefully. Some margarines claim that they contain no cholesterol and are nonhydrogenated yet they contain palm oil.

It is important to note that many recipes developed for weight reduction diets tend to cut out carbohydrate foods in order to decrease weight and may even introduce foods that increase blood clotting and cholesterol. Therefore, be careful in choosing “popular” weight reduction diets. Consult Table 4 and the instructions given in the chapter on Heart Attacks.

TABLE 4

Saturated Fat, Polyunsaturated and Cholesterol Content of Foods

ITEM* mg	Cholesterol g	Total Fat g	Sat/ Fat _{not rec}	Recom	Sparingly
MEATS					
Beef liver	395	10	3	X	
Kidney	725	11	4	X	
Sweetbread	420	21	—	X	
Lean beef	82	5	2	.	.
Roast beef					
Rib	85	33	14	X	.
Rump	85	21	9	X	.
Stewing	82	27	11	X	.
Lean	82	9	4	.	.
Ground	85	18	8	X	.
Steak					
Sirloin	85	25	10	X	.
Lean	85	5	2	.	.
Veal	90	12	5	.	.
Lamb					
Lean	90	7	4	.	.
Chop & fat	110	33	18	X	
Ham					
Fat roasted	80	28	7	X	
Boiled, sliced	80	18	5	.	.
Pork chop	80	30	12	X	
Chicken					
Breast					
and skin	72	6	1	.	.
Drumstick					
Fried	80	9	2	.	.
Turkey	80	5	2	.	.
FISH					
Sole	45	1 trace	.	.	.
Trout	50	13	3	.	.
Tuna	60	7	2	.	.
Butter	30	11	9	trace	.
			7		
Lard	12	13	5	1	X
OILS					
Canola	0	14	5	8	.
Corn oil	0	14	1	7	.
Rapeseed	0	14	1	3	X
Safflower	0	13	1	10	.
Sunflower	0	14	1	9	.
Soybean	0	14	2	7	.
Coconut	0	14	12	2	X
Palm olive	0		7 2	.2	X
	0	14	1	.	.
Peanut	14		2	4	X

TABLE 4

(Continued)

ITEM* mg	Cholesterol g	Total Fat g	Sat/ Fat _{not rec}	Recom	Sparingly
Cheese 1 oz					
Brick	27	8	6	trace	.
Blue	24			trace	.
Cheddar	30	10	6	trace	.
Cottage skim milk	2.6	.5		trace	.
Processed	0 trace			trace	.
NUTS [1 oz 30 g]					
Almonds [~24nuts]	0	14	1.5	3 [P]	10 [M]**
Brazil nuts	0	19	5	7 [P]	7 [M] X
Cashews [18 nuts]	0	13	2.5	2.5 [p]	8 [M] X
Coconut	0	13	11	trace	X
Hazelnuts [12]	0	18	1	2 [p]	15 [m]
Peanuts [35]	0	14	2	5 [P]	7 [M] X
Butter pecans	0	19	2	5 [P]	12 [M] X
Walnuts 0 18 [7nuts]				<P>2	11 [P] 5 [M] ..

*Quantity is 3 oz, 90 g unless specified, 15 ml = one tablespoon.

**Foods recommended contain less than 5 g saturated fat per 3 oz.

Total Saturated Polyunsat- Not Use ITEM* Cholesterol Fat Fat urated
Recom.Recom." Sparingly P = polyunsaturated, M = monounsaturated

C. Nuts and Cholesterol and Risk

Most nuts contain no cholesterol and very little saturated fats, but the exceptions include coconut and Brazil nuts which have high saturated fat content and their products should be avoided (see Table 4). Cashew nuts and peanuts have significant saturated fats, and although they contain an adequate amount of monounsaturated and polyunsaturated fatty acids, they are not recommended and should be used sparingly. Additionally, it appears that peanuts may have atherogenic potential. Nuts that contain little saturated fat and a high amount of monounsaturated fats include almonds, walnuts, and hazelnuts and their intake is highly recommended.

D. General Advice on Diets

Diets to reduce atherosclerosis or heart attacks must be tailored to meet the needs of the individual, because each family has different eating habits. Special recipes and diet sheets may be misleading and difficult to follow for a lifetime and individuals should consult Table 4, or similar information.

It is recommended that the general population use foods that contain a low amount of saturated fat and cholesterol and make an effort to increase intake of polyunsaturated

and monounsaturated fat, linolenic acid, and foods that have a favorable effect on blood clotting (see the chapter Blood Clots). Reduction in the intake of cholesterol alone is not sufficient because saturated fat is converted into cholesterol in the body; therefore, reduction in saturated fat intake is essential. Most important, the intake of trans fat must be curtailed (see chapter Diets and Heart Disease).

The recommendation made by the American Heart Association is as follows:

Total fat intake should be reduced from the average 40% of calories to 30%. Polyunsaturated fat should provide up to 10% of calories and the polyunsaturated fat to saturated fat (P/S) ratio should be about 1:1. Carbohydrate intake should be increased from an average of about 45%–55% to maintain average body weight, and protein intake should remain at about 12–14%.

Scotland has not shared, however, in the slight decline in mortality that has been experienced in Australia, Belgium, Canada, Finland, Norway, and the United States. Scotland has moved up in the world league of coronary deaths to second for men, and Northern Ireland has moved to third for men and second for women. In the UK, fat intake has remained the same for the past 30 years at about 40% of food energy and even increased between 1974 and 1982 to 41% of food energy. The Department of Health and Social Security made the following recommendations to physicians and the general public in the UK:

Reduce the total fat intake to 35% of food energy with saturated fats making up no more than 11%. Increase the polyunsaturated to saturated ratio from the present 0.27 to about 0.45. The intake of polyunsaturated acids presently at 5% of food energy should reach 7%, which is less than the American and World Health Organization's suggestion of 10%.

The UK panel claims that the effects on the population of a P/S ratio of 1.0 and beyond are unknown. Individuals who are considered to have a high risk of developing coronary heart disease are advised to cut fats to 30% of food energy, with saturated fats contributing no more than 10%, i.e., identical to the recommendation in the United States. Thus there is consensus on both sides of the Atlantic.

A Mediterranean style diet that contains an abundance of linolenic acids is strongly recommended by the author; see the chapter Diets and Heart Disease.

The reduction in dietary saturated fat intake as well as the cessation of smoking by many individuals has provided a decline in the incidence of coronary heart disease mortality.

VIII. CHOLESTEROL-LOWERING DRUGS

A. HMC-CoA Reductase Inhibitors (Statins)

The statins, atorvastatin, fluvastatin, lovastatin, pravastatin, and simvastatin, are cholesterol-lowering agents that are effective and have few side effects. They cause a 20–40% reduction in total, or LDL, cholesterol. They may cause a small, 1–6%, increase in HDL cholesterol, but this effect is variable. Clinical trials have shown that these agents decrease LDL cholesterol levels and reduce the risk of heart attack and death from heart attacks. The newest agent, rosuvastatin, is even more powerful than Lipitor in reducing LDL levels to goal. Randomized clinical trials that document the effectiveness of these agents are given in the chapter Dyslipidemia.

Mild side effects from statins include headaches, muscle aches, and pain in the upper abdomen without gastritis, ulcers, or bleeding. An increase in the liver enzymes may be detected on blood test, but the risk subsides when the drug is discontinued. **Caution:** Do not take with niacin or fibrates such as gemfibrozil or fenofibrate. Statins are contraindicated in pregnancy.

1. Atorvastatin

Supplied: Tablets: 10, 20, 40, 60 mg.

Dosage: 10–40 mg once daily; the author's maximum dose is 60 mg daily. The 80 mg dose is rarely required and more adverse effects may occur at the maximal dose of the drug.

2. Fluvastatin

Supplied: Capsules: 20 mg.

Dosage: 20–40 mg after the evening meal or bedtime.

3. Lovastatin

Supplied: Tablets: 10, 20, 40 mg.

Dosage: 10–40 mg after the evening meal.

4. Pravastatin

Supplied: Tablets: 10, 20, 40 mg.

Dosage: 10–40 mg after the evening meal or bedtime.

5. Rosuvastatin

Supplied: Tablets: 10, 20, 40 mg.

Dosage: 10 mg once daily is more effective in lowering LDL cholesterol than 40 mg of Lipitor or simvastatin. It causes a better increase in HDL cholesterol. The author's maximum suggested dose is 20 mg daily.

6. Simvastatin

Supplied: Tablets: 5, 10, 20, 40, 60 mg.

Dosage: 10–40 mg after the evening meal.

B. Cholesterol Absorption Inhibitors

I. Ezetimibe

Supplied: Tablets 10 mg.

Dosage: 10 mg once daily. This drug has a low side effect profile and can be combined with a statin.

C. Resins

I. Cholestyramine

Supplied: Powder in packets or in cans with a scoop.

Dosage: 12–24 g daily in liquid a half hour before to a half hour after meals. Start with 4 g (one scoop) twice daily for one week, then 4 g three times daily for one month, and if necessary, thereafter increase to 8 g three times daily.

Cholestyramine and colestipol are not absorbed from the gut and act by binding bile salts in the intestine. This action causes the liver to increase the conversion of cholesterol to bile acids, which are excreted in the bile.

Cholestyramine has no serious side effects. Constipation, nausea, bloating, gas, and abdominal cramps may occur. High doses taken for several years can cause poor absorption of certain vitamins. It may interfere with the absorption of digoxin and blood thinners (anticoagulants). The recent introduction of ezetimibe as an effective drug will render bile acid resins such as cholestyramine and colestipol obsolete.

D. Fibrates

I. Gemfibrozil

Supplied: Capsules: 300 mg.

Dosage: 300 mg taken about a half hour before the morning and the evening meal for one to two weeks, then 300 mg twice daily.

Gemfibrozil is the first fibrate to be introduced in the seventies since the discontinuation of clofibrate in the late sixties. This drug causes a 5–10% reduction in serum

cholesterol, 30% reduction in triglycerides, and a 5–10 % increase in HDL cholesterol. Side effects include stomach pain and bloating in less than 5% of patients. Gallstones may occur.

In the VA-HIT study gemfibrozil caused a 31% decrease in triglycerides, but only a 6% increase in HDL cholesterol compared with placebo. This negligible increase in HDL is claimed to have caused a beneficial reduction in cardiac events. There was no reduction in all cause mortality or in total cardiac mortality; there was a small, 22% reduction in total cardiac death and nonfatal myocardial infarction (MI) ($P < 0.05$), a low level of significance. Virtually all of the benefit was due to reduction in nonfatal MIs; a result similar to that observed for vitamin E in the CHAOS study.

2. Fenofibrate

Supplied: Tablets 100, 160 mg.

Dosage: 100–200 mg once daily with the main meal, maximum 100 mg in renal dysfunction.

3. Bezafibrate

Supplied: Tablets 200 mg.

Dosage: Mono formulation once daily in the evening.

E. Niacin (Nicotinic Acid)

This drug is not often used because of prominent side effects, which include flushing, itching, nausea, abdominal pain, diarrhea, jaundice, gout, palpitations, and increased blood sugar in diabetics. This drug should not be used if you have low blood pressure or have had a heart attack, heart failure, liver disease, a stomach ulcer, or diabetes. It is not advisable to combine niacin with statins because severe damage to muscles and the kidneys may occur.

F. Combination Therapy

The combination of simvastatin and ezetimibe has been shown in a clinical trial to be more effective than simvastatin alone. The combination caused LDL cholesterol reductions of 44–57% and HDL cholesterol increases of 8%–11%. Ezetimibe 10 mg plus simvastatin 10 mg and simvastatin 80 mg alone each caused a 44% reduction in LDL cholesterol. The combination was well tolerated with the safety profile similar to those of simvastatin and of placebo.

The combination of rosuvastatin and ezetimibe is advisable for severe hypercholesterolemia. This is the most powerful combination available for the reduction

of elevated LDL cholesterol and is a welcome addition to the clinician's armamentarium. Caution is required, however, because liver dysfunction or rhabdomyolysis may be precipitated at high doses of any statin, particularly if drug interaction occurs.

BIBLIOGRAPHY

- Ashley, F. W., and Kannel, W. B., Relation of weight change to changes in atherogenic traits. The Framingham study. *J. Chronic Dis.*, 27:103–14, 1974.
- Belfrage, P., Berg, B., Hagerstrand, I. et al. Alterations of lipid metabolism in healthy volunteers during long-term ethanol intake. *Eur. J. Clin. Invest.*, 7:127–31, 1997.
- Boekholdt, S. M., Kuivenhoven, J. A., Wareham, N. J. et al. The prospective EPIC (European Prospective Investigation into Cancer and nutrition)–Norfolk population study: Plasma levels of cholesteryl ester transfer protein and the risk of future coronary artery disease in apparently healthy men and women. *Circulation*, 110:1418–1423, 2004.
- Brousseau, M. E., Schafer, E. J., and Wolfe, M. L. Effects of an inhibitor of cholesteryl ester transfer protein on HDL cholesterol. *N. Engl. J. Med.*, 350:1505–1515, 2004.
- Brown, M. S., and Goldstein, J. L. A receptor-mediated pathway for cholesterol homeostasis. *Science*, 323:361, 1979.
- Cannon, C. P., Braunwald, E., McCabe, C. H. et al. Intensive versus moderate lipid lowering with statins after acute coronary syndromes [PROVE IT – TIMI 22 trial]. National Cholesterol Education Program et al. Detection, evaluation, and treatment of high blood cholesterol in adults. (Adult Treatment Panel II). 2002. *N. Engl. J. Med.*, 350:1495–1504, 2004.
- CARE: the cholesterol and recurrent events trial investigators: The effect of pravastatin on coronary events after myocardial infarction in patients with average cholesterol levels. *N. Engl. J. Med.*, 335:1001–9, 1996.
- Davidson, M. H., McGarry, T., Bettis, R. et al. Ezetimibe coadministered with simvastatin in patients with primary hypercholesterolemia. *J. Am. Coll. Cardiol.*, 40:2125–34, 2002.
- Executive Summary of the Third Report of the National Cholesterol Education Program (NCEP) expert panel on detection, evaluation, and treatment of high blood cholesterol in adults (Adult Treatment Panel III). *JAMA*, 85:2486–96, 2001.
- Gotto, A. M., and Brinton, E. A. Assessing the lower levels of high-density lipoprotein cholesterol as the risk factor in coronary heart disease. In a working group report and update. *J. Am. Coll. Cardiol.*, 43:717–724, 2004.
- Graham, D. J., Staffa, J. A., Shatin, D. et al. Incidence of hospitalized rhabdomyolysis in patients treated with lipid-lowering drugs. *JAMA*, 292:2585–2590, 2004.
- Heart Protection Study Collaborative Group. Effects of cholesterol lowering with simvastatin on stroke and other major vascular events in 20536 people with cerebrovascular disease or other high risk conditions. *Lancet*, 363:757–767, 2004.
- Kuczmarski, R. J., Flegal, K. M., Campbell, S. M. et al. Increasing prevalence of overweight among US adults. *JAMA*, 272:205–11, 1994.
- Lakshminarayanan, D. H., Azen, S. P., Krams, D. M., and the MARS Research Group et al. MARS Study—The Monitored Atherosclerosis Regression Study: Coronary angiographic changes with lovastatin therapy. *Ann. Intern. Med.*, 119:969, 1993.
- LIPID: The long term intervention with pravastatin in ischaemic disease (LIPID) Study Group. Prevention of cardiovascular events and death with pravastatin in patients with coronary heart disease and a broad range of initial cholesterol levels. *N. Engl. J. Med.*, 339:1349–57, 1998.
- MAAS Investigators et al. Effect of simvastatin on coronary atheroma: The Multi-Centre Anti Atheroma Study (MAAS). *Lancet*, 344:633, 1994.
- Mann, G. V. et al. Metabolic consequences of dietary trans fatty acids. *Lancet*, 343:1268, 1994.
- Mullin, G. E., Greenson, J. K., Mitchell, M. C. et al. Fulminant hepatic failure after ingestion of sustained-release nicotinic acid. *Ann. Intern. Med.*, 111:253, 1989.
- Murray, C. J. L., and Lopez, A. D. *The Global Burden of Disease*. Harvard School of Public Health, Cambridge, MA, 1996.
- Nissen, S. E., Tsunoda, T., Tuzcu, E. M. et al. Effect of recombinant ApoA-I Milano on coronary atherosclerosis in patients with acute coronary syndromes: A randomized controlled trial. *JAMA*, 290:2292–2300, 2003.
- Nissen, S. E. et al. For the REVERSAL Investigators: REVERSAL comparison of intensive versus moderate lipid lowering on the progression of coronary atherosclerosis measured by intravascular ultrasound: A randomized controlled trial. *Circulation*, 108:2723, 2003.
- O'Neil-Callahan, K., Katsimaglis, G., Tepe, M. R. et al. Statins decrease perioperative cardiac complications in patients undergoing noncardiac vascular surgery. *J. Am. Coll. Cardiol.*, 45:336–342, 2005.
- Pietinen, P., and Huttunen, J. K. The dietary determinants of plasma high density lipoprotein cholesterol. *Am. Heart J.*, 113:620–25, 1987.
- Ridker, P. M., Cannon, C. P., Morrow, D. et al. For the Pravastatin or Atorvastatin Evaluation and Infection Therapy–Thrombolysis in Myocardial Infarction 22 (PROVE IT–TIMI 22) Investigator: C-reactive protein levels and outcomes after statin therapy. *N. Engl. J. Med.*, 352:20–28, 2005.
- Sans, S., Kesteloot, H., and Kromhout, D. The burden of cardiovascular diseases mortality in Europe. Task force of the European society of cardiology on cardiovascular mortality and morbidity statistics in Europe. *Eur. Heart J.*, 18:1231–48, 1997.
- Scandinavian simvastatin survival Study group: Randomized trial of cholesterol lowering in 4444 patients with coronary heart disease: The Scandinavian simvastatin survival study (4S). *Lancet*, 344:1383, 1994.
- Schwartz, G. G., Olsson, A. G., Ezekowitz, M. D. et al. MIRACL: Effects of atorvastatin on early recurrent ischemic events in acute coronary syndromes: A randomized controlled trial. *JAMA*, 285:1711–1718, 2001.
- Shepherd, J., Cobbe, S. M., Ford, I. et al. Prevention of coronary heart disease with pravastatin in men with hypercholesterolemia. *N. Engl. J. Med.*, 333:1301, 1995.
- Strey, C. H., Young, J. M., Molyneux, S. L. et al. Endothelium-ameliorating effects of statin therapy and coenzyme Q₁₀ reductions in chronic heart failure. *Atherosclerosis*, 179: Issue 1 201–206, 2005.
- Thompson, P. D., Clarkson, P., Karas, R. H. et al. Statin-associated myopathy. *JAMA*, 289:1681–1690, 2003.
- Toth, P. P. et al. The “good cholesterol”: High-density lipoprotein. *Circulation*, 111:e89–e91, 2005.
- Wallerath, T., Poleo, D., Li, H. et al. Red wine increases the expression of human endothelial nitric oxide synthase. *J. Am. Coll. Cardiol.*, 41:471–8, 2003.
- World Health Report 1999: Making a Difference. Geneva, World Health Organization, 1999.

Coenzyme Q10

- I. Actions
- II. Clinical Study
- III. Prospective and Research Implications

GLOSSARY

heart failure failure of the heart to pump sufficient blood from the chambers into the aorta; and inadequate supply of blood reaches organs and tissues.

pulmonary edema fluid in the air sacs and alveoli; the lungs become congested and severe shortness of breath occurs.

I. ACTIONS

The enzyme Q10 (ubiquinone), a quinone, was discovered in 1957, and since that time there has been considerable controversy regarding its use in heart failure and other forms of heart disease. This enzyme serves as a mitochondrial enzyme supplement and appears to improve defective myocyte energetics in patients with heart failure. Coenzyme Q10 plays an intermediary role in the electron transport chain during the oxidation of reduced nicotinamide adenine dinucleotide (NADH) or succinate, with the conversion of oxygen to water within the mitochondria (see Fig. 1). This enzyme is involved in electron proton transfer during oxidative phosphorylation. Also, coenzyme Q10 possesses antioxidant, free radical scavenging, and membrane stabilizing properties.

There is no doubt that myocyte energetics and mitochondrial function is severely deranged in patients with heart failure and salutary cardioactive agents are wanting. There have been major advances in the management of heart failure during the past decade, but the epidemic of heart failure continues worldwide. To stop this epidemic, it is crucial that new cardioactive agents are found.

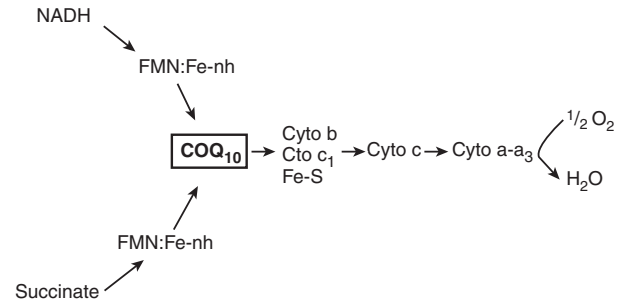

FIGURE 1 The role of coenzyme Q₁₀ (CoQ₁₀) in electron transport. CoQ₁₀ plays an intermediary role in the electron transport chain during the oxidation of reduced nicotinamide adenine dinucleotide (NADH) or succinate, with the ultimate conversion of oxygen to water within the mitochondria. Cyto Cytochrome; FAD Flavin adenine dinucleotide; Fe-nh Nonheme iron; Fe-S Iron disulfide; FMN Flavin mononucleotide. (From Raj, S.R., Weisel, R.D., and Verma, S. (2002). *Can. J. Cardiol.*, 18(10), 1054.)

II. CLINICAL STUDY

Several small clinical studies of coenzyme Q10 that have not been randomized indicate an improvement in physical activity. A nonrandomized, nonblinded, four-week study of 1715 patients reported improvement in symptoms and quality of life. A longer study using 100 mg daily for over 6 years reported improvement in ejection fraction. A small study suggested degeneration in symptoms and hemodynamic features on discontinuation of the enzyme. A randomized study without placebo control in 806 patients showed improvement in functional class and heart failure symptoms over a 6-month follow up.

The results of a few small double-blind, randomized placebo-controlled trials are given in Table 1. In most of the studies involving less than 50 patients no reasonable conclusion can be drawn. In 1993 the largest double-blind, randomized study involving 591 patients followed for one year showed hospitalizations were decreased with the enzyme; 40% versus 20% for placebo ($p < 0.001$).

TABLE I

Double-blind, Placebo Controlled, Randomized Trials of Coenzyme Q₁₀ (CoQ₁₀) for Congestive Heart Failure

First author (reference)	Year	Design	n	Etiology of heart failure	NYHA class (enrolment)	CoQ ₁₀ dose (mg/day)	CoQ ₁₀ treatment duration (weeks)	Results
Trials enrolling 20 or fewer patients								
Langsjoen (12)	1985	Xover	19	DCM	III-IV	100	12	↑SV by IC, ↑EF, ↑general activity
Judy (13)	1986	Xover	14	DCM	IV	100	12	↑CO, ↑SV, ↑EF by IC
Mazzola (15)	1987	Xover	20	Mixed	II-III	60	4	Improved NYHA score
Rossi (14)	1991	Parallel	20	CAD	N/A	200	12	↑Exercise capacity No change in EF by echo No change in CO by IC
Poggesi (16)	1991	Xover	18	Mixed	II-III	100	8	↑EF by echo (45.7% to 49.1%) ↑FS by echo (26.6% to 29%)
Morisco (17)	1994	Xover	6	Mixed	II-III	150	4	↑CO, ↑EF, ↑SV by radionuclide assessment
Trials enrolling more than 20 patients								
Permanetter (20)	1992	Xover	25	DCM	I-III	100	16	No change in EF by MUGA No change in CO or SV by IC No change in exercise tolerance
Morisco (18)	1993	Parallel	641	Mixed	III-IV	100-150	52	↓CHF hospitalizations ↑Functional capacity
Hofman-Bang (19)	1995	Xover	79	Mixed	II-IV	100	12	No change in mortality No change in EF by MUGA No change in NYHA class Minimal increase in work capacity Minimal increase in QOL
Watson (21)	1999	Xover	27	Mixed	II-III	100	12	No change in LV dimensions No change in CO (thermodilution) No change in QOL
Khattri (22)	2000	Parallel	46	Mixed	III-IV	200	26	No change in EF by MUGA No change in peak oxygen consumption No change in exercise duration

Note: ↓Decrease; ↑Increase. CAD Coronary artery disease; CHF Congestive heart failure; CO Cardiac output; DCM Nonischemic dilated cardiomyopathy; echo Echocardiography; EF Ejection fraction; FS Fractional shortening; IC Impedance cardiograph; LV Left ventricular; MUGA Gated radionuclide assessment; n Number of patients; N/A Not available; NYHA New York Heart Association; QOL Quality of life; SV stroke volume; Xover Cross-over. (From Raj, S.R., Weisel, R.D., and Verma, S. (2002). *Curr. J. Cardiol.*, 18(10), 1056.)

The enzyme group had fewer patients with pulmonary edema, 20 versus 51, and cardiac asthma, 97 versus 198 ($p < 0.001$). There was no difference in survival between the two groups. More recently studies with less than 55 patients receiving optimal heart failure therapy showed no differences.

III. PROSPECTIVE AND RESEARCH IMPLICATIONS

A small study indicated that statin therapy reduces plasma levels of coenzyme Q10, which may have adverse effects on heart failure states. Further studies are needed to determine whether ubiquinone reductions are limiting the maximum favorable effects of statin therapy on the microcirculation.

The use of enzyme Q10 carries only one disadvantage — neglect of approved heart failure remedies. Further studies

are clearly indicated because the enzyme appears to cause no harm and appears to alter parameters that are deranged in heart failure that are not corrected by the excellent cardioactive agents available for the management of heart failure. These agents include ACE inhibitors, diuretics, beta-blockers, digoxin, spironolactone, and eplerenone. Intensive research is required to obtain new cardioactive agents to manage heart failure (see the chapter Heart Failure).

BIBLIOGRAPHY

- Raj, S. R., Weisel, R. D., and Verma, S. Coenzyme Q10 and congestive heart failure: What is the verdict? *Can. J. Cardiol.*, 18:1054–57, 2002.
- Strey, C. H., Young, J. M., Molyneux, S. L. et al. Endothelium-ameliorating effects of statin therapy and coenzyme Q10 reductions in chronic heart failure. *Atherosclerosis*, 179: Issue 1 201–206, 2005.

Congenital Heart Disease

- I. Incidence and Classification
- II. Ventricular Septal Defect
- III. Patent Ductus Arteriosus
- IV. Aortic Stenosis
- V. Bicuspid Aortic Valve
- VI. Coarctation of the Aorta
- VII. Other Congenital Anomalies
- VIII. Congenital Cyanotic Heart Disease
- IX. Pregnancy and Congenital Heart Disease

GLOSSARY

- autograft** a tissue graft transferred from one part of the patient's body to another part.
- commissures** a site of union of corresponding parts, especially the sites of junction between the adjacent cusps of the heart valves.
- cyanosis** purplish-blue discoloration of the lips, tongue, mucous membranes, ear lobes, extremities, fingers, and toes.
- endocarditis** infection on deformed or damaged valves in the heart, or at the site of a hole in the heart (ventricular septal defect).
- heterograft** a graft of tissue taken from a donor of one species and grafted into a recipient of another species, also called a xenograft.
- homograft** a graft of tissue taken from a donor of the same species as the recipient.
- hypoxemia** severe lack of oxygen in the blood.
- ischemia** temporary lack of blood and oxygen to an area of cells, for example, the heart muscle, usually due to severe obstruction of the artery supplying blood to this area of cells.
- murmur** a blowing sound heard with a stethoscope usually caused by obstruction of heart valves or leaking valves.
- myocardial infarction** death of an area of heart muscle due to blockage of a coronary artery by blood clot or atheroma; medical term for a heart attack or coronary thrombosis.
- oligohydramnios** Deficiency in the amount of amniotic fluid.
- syncope** temporary loss of consciousness caused by lack of blood supply to the brain; fainting describes a simple syncopal attack.

I. INCIDENCE AND CLASSIFICATION

The incidence of moderate and severe forms of congenital heart disease (CHD) is about 6 per 1000 live births, but it is 19 per 1000 live births if the potentially serious bicuspid aortic valve is included. If very small muscular ventricular septal defects (VSDs) are included, all forms increase to 75 per 1000 live births. Although several classifications are used, the oldest and most meaningful is the division into cyanotic and noncyanotic CHD.

Cyanotic CHD involves right-to-left shunts. The arterial circulatory system receives an overflow of deoxygenated blood from the right side of the heart resulting in a discoloration of the tongue, lips, and mucous membranes. Organs and tissues receive blood low in oxygen. Noncyanotic CHD mainly involves left-to-right shunts and valvular defects. In individuals with left-to-right shunts oxygenated blood flows from the left side of the heart into the right atrium or ventricle and is returned to the lungs. Usually there is no significant hypoxemia, except in children with severe defects. Fortunately noncyanotic CHD is much more common than cyanotic disease. The noncyanotic group includes the following:

1. Ventricular septal defect, incidence ~30%, more than 80% close before age 2–3
2. Patent ductus arteriosus, ~10%
3. Atrial septal defects (ASD of the fossa ovalis secundum defects), ~10%
4. Atrioventricular septal defects (endocardial cushion defects, a common atrioventricular canal)
5. Pulmonary stenosis, ~7%
6. Aortic stenosis, ~6%
7. Bicuspid aortic valves, common
8. Coarctation of aorta, ~7%
9. Mitral regurgitation, rare
10. Anomalous origin of coronary artery

The cyanotic group includes the following:

1. Tetralogy of Fallot, ~6%
2. Persistent truncus arteriosus, ~2%

3. Hypoplastic right heart includes tricuspid stenosis, pulmonary atresia with an intact ventricular septum, and Ebstein anomaly ~16%
4. Total anomalous pulmonary venous connection, ~16%
5. Critical pulmonary stenosis, ~16%
6. D-transposition of great arteries, ~16%

There are few definite differences in the incidence of some forms of CHD in different populations. There is a high proportion of subarterial VSDs in China and Japan ~35% versus 5% in Caucasians. In Malta there is an excessive incidence of tetralogy of Fallot. Aortic stenosis and coarctation are more common in Caucasians than in the black or Hispanic population in the United States.

II. VENTRICULAR SEPTAL DEFECT

Ventricular septal defects are the most common form of congenital heart disease. If all newborns are examined about 3% would reveal tiny muscular VSDs. Spontaneous closure occurs by age 3 in greater than 50% of patients born with VSDs. Still, VSDs after age 2 represent the most

common lesion if bicuspid aortic valves are not included in the equation. Occasionally children, however, may not experience spontaneous closure up until age 10.

A. Clinical Features

Small VSDs are usually asymptomatic. Oxygenated blood rushes from the left ventricle through a hole in the septum that separates the right and left ventricles (see Fig. 1). The blood traverses this hole at high velocity and sets up turbulence that is heard as a murmur with a stethoscope. The murmur is produced as the left ventricle contracts in systole. A harsh systolic murmur is heard with maximal intensity at the left lower sternal border and is well heard to the left and right of the sternum with less intensity at the apex of the heart. The murmur radiates from the point of maximal intensity like the spokes of a wheel. A thrill may be felt with the palm of the hand in the region where the murmur was best heard with the stethoscope. Because of these typical features the diagnosis can usually be made with the simple stethoscope.

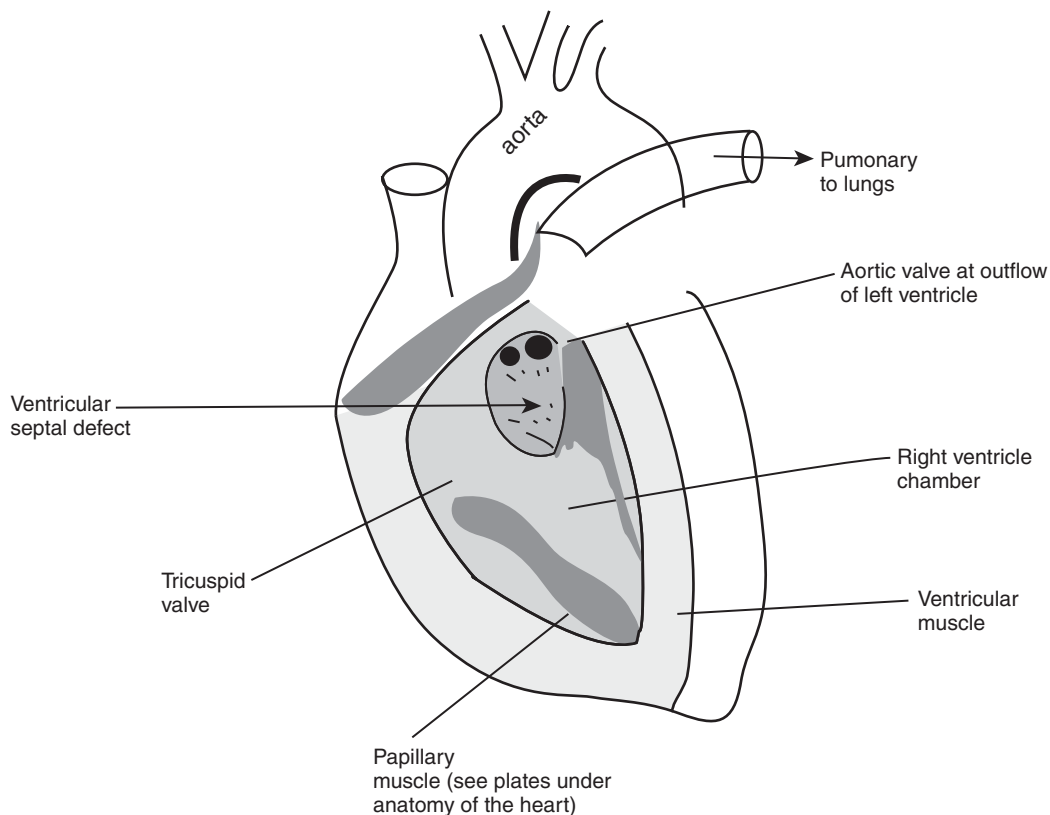

FIGURE I Ventricular septal defect. See Figures 5 and 6 in the chapter entitled Anatomy of the Heart and Circulation.

B. Clinical Study, Gabriel et al.

Study question: The study is to assess long-term outcome of patients with small VSDs in whom surgical closure is not usually recommended.

Methods: A total of 229 children with VSDs considered too small to require surgery, i.e., less than 50% shunt with normal pulmonary artery pressure. Follow up is to mean age of 30 ± 10 years.

Results: Spontaneous closure was observed in 14 patients (6%). No patient died, 4 patients developed endocarditis, and only one patient required surgical closure. Surgical closure does not appear to be required during childhood as long as the left-to-right shunt is less than 50% and signs of left ventricular volume overload are absent, pulmonary artery pressure is not elevated, and there are no symptoms related to aortic regurgitation. The outcome in well-selected patients with small VSDs is good. The study findings are in agreement with current practice.

C. Perspective

With a VSD blood flows from the left ventricle with a hole in the septum into the right ventricle. If this left-to-right shunt is greater than 50%, symptoms such as shortness of breath and fatigue may occur and these may increase in severity. It is of utmost importance to identify patients who may develop irreversible pulmonary vascular obstructive disease (Eisenmenger's syndrome). An increase in the resistance of the pulmonary circulation causes increased workload and strain on the right ventricle with subsequent heart failure. The shunt of blood from the left ventricle to the right ventricle through the hole in the septum may be reversed so that blood then flows from the right ventricle into the left ventricle. This reversal of the shunt from right to left must be prevented, and surgical correction must be employed long before this complication occurs. This condition may occur with large shunts or with complicated defects associated with pulmonary stenosis, aortic regurgitation, and other lesions.

Echocardiography identifies and quantifies the VSD. If the shunt is significant or symptoms are present, catheterization should be performed to determine the pressure and blood flow in the pulmonary artery. With larger shunts, elective surgery is usually advised before the child enters school.

In all patients with VSDs, it is necessary to enforce prophylactic antibiotic therapy before dental and other minor surgical procedures. Antibiotics prevent the growth of organisms that attach to the wall of the heart at the site of the VSD. This dangerous condition is called infective

endocarditis. Although small defects cause no symptoms and may never require surgery, endocarditis can occur at the site of the defect and prophylaxis is lifesaving.

III. PATENT DUCTUS ARTERIOSUS

Patent ductus arteriosus is a common lesion occurring in approximately 10% of infants, about the same incidence as ASD. In the fetus a widely opened, patent vessel connects the pulmonary trunk to the descending aorta. This patent vessel is called a patent ductus arteriosus, (see Fig. 2). Thus, the output of deoxygenated blood from the right ventricle bypasses the unexpanded lungs of the fetus. Blood is propelled from the right ventricle into the pulmonary trunk and through the patent ductus and enters the descending aorta where it is carried to the fetal organ of oxygenation, the placenta.

Sensitive studies have shown that in the term infant the ductus is almost always closed by 4–7 days and in some instances several weeks after birth. It was a long held view that the ductus, no longer required as a vital conduit, closes soon after birth because of the abrupt rise in arterial oxygen that accompanies the first breath of the baby. The closure of the ductus is not only related to the sudden increase in the pressures of oxygen that accompany the ventilation in the newborn, but also related to the actions of vasoactive compounds that stimulate proliferation of cells and fibrosis that produce a complete closure. Preterm infants have an increased incidence of a patent ductus based on abnormal physiology rather than on a structural

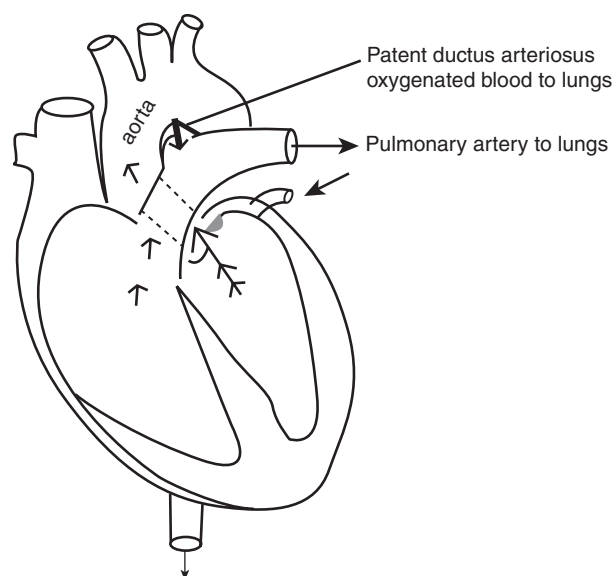

FIGURE 2 Patent ductus arteriosus: left to right shunt.

abnormality. In the preterm infant the patent ductus may cause minor problems, but if other serious congenital malformations coexist the shunting of blood through the ductus provides a unique mechanism that can be lifesaving.

A. Clinical Features

In the term infant with a patent ductus oxygenated blood flows from the aorta backward into the pulmonary trunk, because the blood pressure and aorta is several times higher than that in the pulmonary circulation. This shunting of blood is called a left-to-right shunt that is similar to that described above with VSDs and ASDs. Left-to-right shunts are noncyanotic congenital heart lesions that are usually well tolerated by the body and give rise to problems only when they are very large shunts or other lesions coexist.

Examination of the infant by the physician reveals a loud continuous machinery-like murmur that is best heard at the upper left after breastbone (sternum). The opening of the palm of the hand placed in this area may detect a vibratory sensation called a thrill. A typical finding is bounding peripheral pulses that can be felt at the wrist and the top (dorsum) of the feet (the dorsalis pedis artery).

B. Treatment

The presence of a patent ductus necessitates its closure, which can be done at low risk. Surgical ligation is simple, but the newer techniques using transcatheter closure appear promising. A patent ductus may coexist with other malformations such as coarctation of the aorta and valvular aortic stenosis, and these lesions must be excluded before simple ligation of the ductus. A patent ductus is a potential site of endocarditis and prophylactic antibiotics are required.

With an ASD, however, because the flow across this left-to-right shunt is small, endocarditis is extremely rare and antibiotic prophylaxis is usually not recommended. It is one of the few heart lesions in which a murmur is heard and deformities are present for which prophylaxis is not required.

IV. AORTIC STENOSIS

The normal aortic valve has three leaflets. With congenital aortic stenosis the valve is often bicuspid (two leaflets). The aortic valve leaflets are thickened and fusion occurs at

the commissures, which results in obstruction to the valve so that blood flow from the left ventricle into the aorta is restricted, (see figures in the chapter Anatomy of the Heart and Circulation for normal aortic valve and heart structures). Severe or moderate degrees of aortic stenosis can be life threatening and surgical correction is necessary. Percutaneous balloon aortic valvuloplasty may delay surgical correction of the deformity in some individuals. Bacterial endocarditis must be prevented with antibiotic coverage.

V. BICUSPID AORTIC VALVE

Bicuspid aortic valve is important because it is the most common congenital heart lesion and often remains undetected until aortic stenosis develops in adults between age 25 and 40. Also, the valve may become incompetent with blood flowing from the aorta back into the left ventricle, a condition called aortic incompetence or aortic regurgitation. A study designed to determine the incidence of CHD reported CHD excluding bicuspid nonstenotic aortic valves as 9596 defects per million live births and 13,556 bicuspid aortic valves per million live births.

The majority of bicuspid valves are well tolerated throughout adult life, but individuals harbor a risk for bacterial endocarditis and antibiotic prophylaxis is required. The diagnosis of bicuspid valve is simple: a murmur is easily heard at the stethoscope in the aortic valve area and the second right intercostal space. The murmur may radiate and may be heard over the neck vessels. Echocardiography confirms the diagnosis.

A. Management and Research Implications

During young adult life the aortic valve may become obstructed or incompetent and must be replaced. The valve has a predilection for calcification which further obstructs the flow of blood. A mechanical valve is superior to a bioprosthetic valve that may only last 12–20 years. A pulmonary autograft, an aortic homograft, or other device may be selected depending on the age of the individual and the preference of the surgical team.

Further research for new valvular structures that are long-lasting but carry no risk of thrombosis is needed.

VI. COARCTATION OF THE AORTA

Coarctation of the aorta is a congenital narrowing of the aorta as the artery winds its way from the top of

the heart. The condition may be discovered when the child is an infant if the coarctation is severe or if an astute physician correctly interprets the signs. About 80% of children with coarctation have a mild coarctation or develop an extensive collateral system of vessels that carry blood past the coarctation. These children may have no symptoms until they reach adolescence; some children have no symptoms until they reach the age of 15–30.

Early diagnosis of coarctation of the aorta is essential to ensure timely surgical or nonsurgical correction. Although there are remarkable specific physical signs that make diagnosis straightforward in the doctor's office, it is one of the most commonly overlooked diagnoses in children. A diagnosis can be made within minutes if the physician feels the femoral pulses and finds them absent or weak. There is also accompanying high blood pressure in the arms and low pressure in the legs. More than 80% of coarctations are situated just beyond the ductus arteriosus and, fortunately, beyond the beginning of the left subclavian artery, which supplies blood to the left upper limb.

Because the aorta is constricted, the limbs are blood starved. There is hypertension in the upper part of the body and the blood pressure is low in the legs. Symptoms result from lack of adequate blood supply to the lower limbs, causing coldness, numbness, heaviness of the legs and feet, pain in the muscles, intermittent claudication, and leg cramps. Other symptoms include dizziness, headaches, nosebleeds, shortness of breath, and palpitations.

Complications from coarctation of the aorta include angina, heart failure, aortic rupture, and cerebral hemorrhage from associated berry aneurysms at the base of the brain. All patients should be screened to exclude berry aneurysms, polycystic kidney disease, and bicuspid aortic valve. Endocarditis of a bicuspid valve or the aorta in the arch or just distal to the coarctation may occur.

Treatment is best achieved with surgery. Balloon dilatation is recommended for recurrent coarctation and has had a success rate of about 80%. Results from the Valvuloplasty and Angioplasty of Congenital Anomalies Registry indicate a success rate that is comparable with surgery for recurrent coarctation. As first-step therapy, however, balloon dilatation is considered investigational. Protection from a rupture during the procedure is of concern because the coarctation area is not surrounded by scar tissue as occurs after surgery. Because dilatation of the artery causes tears in the wall (intima and media), long-term follow up is required to exclude the possibility of aneurysm formation. Continued evaluation and long-term assessment are necessary before the procedure can be considered first choice. Fawzy et al, however, reported on successful long-term outcome [up to 15 years] of

balloon angioplasty of discrete native coarctation of the aorta in adolescents and adults.

After correction of the coarctation, the blood pressure may increase over the ensuing years. Thus close follow up is necessary. Because constriction of the aorta causes reduced blood flow to the kidney, the renin–angiotensin system is stimulated and this increases blood pressure. ACE inhibitors constitute rational therapy for the management of hypertension, but are not always successful.

VII. OTHER CONGENITAL ANOMALIES

A. Coronary Artery Anomalies in Adults

Anomalies are found in less than 1% of patients undergoing coronary angiography and in less than 0.3% of autopsies. Most of these are, however, benign. Anomalies can originate from the coronary artery from the contralateral coronary sinus. The left main and right coronary artery may arise from the left aortic sinus and cause about 8% of serious coronary anomalies. (See coronary ostia in Figures 5 and 9 in the chapter entitled *Anatomy of the Heart and Circulation*.) This anomaly is associated with sudden death. Some of these individuals are asymptomatic until they exercise. Another type of anomaly may originate from a single coronary artery or a coronary artery from the pulmonary artery.

I. Clinical Features

Angina, transient loss of consciousness, syncope, myocardial infarction, heart failure, and sudden death may occur with coronary artery anomalies. Sudden cardiac death in young individuals, particularly athletes, has drawn attention to these anomalies which account for about 15% of these catastrophic events in young adults. Sudden death is more common when the anomalous artery is dominant and supplies a larger part of the heart muscle.

Common causes of sudden cardiac death in young adults include hypertrophic cardiomyopathy (see the chapter *Athletes and Sudden Cardiac Death*), Brugada syndrome (see the chapter *Brugada Syndrome*), and coronary artery anomalies. Usually these defects cause symptoms because of a steal phenomenon — areas of heart muscle deprived of blood with oxygen and nutrients. Chest pain, angina, myocardial infarction, shortness of breath, and syncope may occur. Anomalous origin of the left main coronary artery from the right coronary sinus is more frequently symptomatic than when the right coronary artery arises from the left coronary sinus.

The origin of the left main coronary artery from the pulmonary trunk is a serious condition that usually causes death during early childhood. The ECG shows broad, deep Q waves in leads I, aVL, V5, and V6, and signs of ischemia. Deep Q waves in lead I are rarely seen except in hypertrophic cardiomyopathy. Survival may occur to puberty in a few cases if myocardial collaterals develop from the normally arising right coronary artery. Apart from the ominous electrocardiographic findings that should lead to immediate investigations, auscultation with the stethoscope may reveal a continuous murmur that serves to differentiate the rare condition from all other cardiac abnormalities. Only a patent ductus arteriosus causes a continuous murmur that is usually very loud and machinery-like. These individuals usually present with syncope, undue shortness of breath, angina, myocardial infarction, or sudden death.

Arteriovenous malformations (AVMs) are anomalous lesions of concern that occur in the brain where hemorrhage can cause devastating effects. The usual presentation is a hemorrhage, seizures, progressive neurologic deficits, and headache. Recently great advances have been made in the application of endovascular embolization techniques, stereotactic radiosurgery, and microsurgery for the management of AVMs that were previously thought untreatable. The finding of an AVM in one site in the body demands a search for one in other vital organs of the body, particularly the lungs.

Another congenital anomaly is dextrocardia. With this the left chambers of the heart are on the right and the right chambers are on the left. The apex of the heart is formed by the left ventricle and points to the right. There is similar transposition of the abdominal organs so that the spleen is on the right and the liver is on the left. The ECG shows typical features. Figure 3A shows a normal tracing (A) compared with the mirror image of dextrocardia (B). Chest x-ray and echocardiography are diagnostic. Patients usually have no other heart defects and are usually asymptomatic. In patients with dextrocardia but with the abdominal organs in the normal position, other cardiac anomalies coexist and patients may be symptomatic.

See other cardiac anomalies in the chapters Atrial Septal Defect, Patent Foramen Ovale, and Athletes and Sudden Cardiac Death.

VIII. CONGENITAL CYANOTIC HEART DISEASE

Congenital heart disease is a general term that refers to defects of the heart that occur during the development of the fetus. They are present at birth but may be discovered

much later. The exact causes of congenital heart disease, which occurs in about 0.8% of live births, is unknown. Approximately 10% of all congenital cardiac defects can be accounted for by chromosomal aberrations or genetic mutations or transmission. Down syndrome is the most common chromosome aberration and occurs in about 1 in every 700 births; the risk rises steeply if the mother is over age 35 and is as high as 4% for women over age 44. In this condition, an atrial septal defect (ASD), a hole in the septum dividing the top chambers of the heart is common.

Congenital defects associated with prenatal exposure to teratogens, which adversely affect embryonic or fetal development, include infectious vectors such as rubella, and drugs and chemicals including radiation, ACE inhibitors, alcohol, hydantoin, lithium, phenylalanine, thalidomide, trimethadione, valproic acid, vitamin D, and anticoagulants as well others. Because so little is known about the causes of the majority of congenital heart defects, and teratogens are strongly implicated in many, it must be emphasized that no medication should be taken during the first six months of pregnancy without prior consultation of a knowledgeable physician.

Some babies born with congenital heart defects may appear blue (cyanotic) at birth or during early childhood, and during exertion and exercise, some children may become cyanotic. In severe cases, the child is blue even at rest and the ends of the fingers appear club-like. This form of congenital heart disease is called congenital cyanotic heart disease and is caused by blood which is deoxygenated flowing from the right side of the heart to the left side. It is usually caused by a hole in the heart combined with an obstruction to blood flow through one of the valves.

A. Tetralogy of Fallot

This is the most common form of cyanotic CHD observed after one year of age, with an incidence of about 6% of all forms of CHD.

Several defects are involved in this condition.

- A ventricular septal defect (VSD) causes a hole in the septum between the two ventricles.
- Right ventricular outflow obstruction in the area of the pulmonary valve causes hypertrophy of the right ventricle and a higher pressure in the right ventricle. Thus, deoxygenated blood flows through the hole in the heart from the right to the left ventricle. This deoxygenated, or blue blood, is pumped from the left ventricle into the arteries and general circulation. A blue discoloration is imparted to the lips, tongue, earlobes, and other areas.

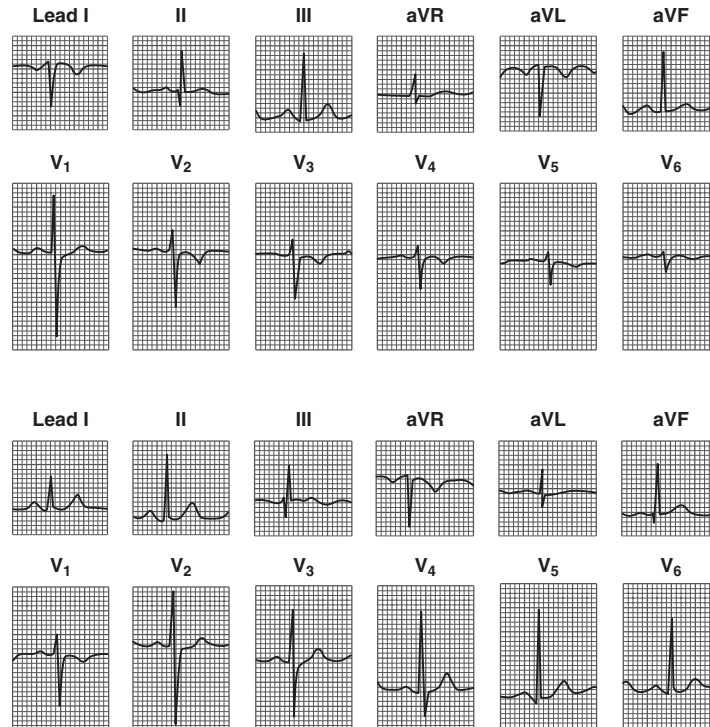

FIGURE 3 Mirror-image dextrocardia with situs inversus. The patient is a 15-year-old girl. There is no evidence of organic heart disease. (A) Tracing recorded with the conventional electrode placement. (B) Tracing obtained with the left and right arm electrodes reversed. The precordial lead electrodes also were relocated in the respective mirror-image positions on the chest. The tracing is within normal limits. (From Chou, T.C. (1996). *Electrocardiography in Clinical Practice*, 4th ed., Philadelphia: W.B. Saunders.)

- There is a dextraposed aorta that is overriding the septal defect.
- Other anomalies, such as an ASD, VSD, or patent ductus, can cause a right-to-left-shunt and cyanotic problems if they are associated with pulmonary hypertension and enlargement of the right ventricle that markedly increases the right ventricular pressures.

The majority of congenital heart defects, however, result in blood flow from the left side of the heart carrying oxygenated blood into the right side, thus no bluish discoloration is observed. These children may have a completely normal childhood, and the defect is discovered in adolescence or young adulthood. In both congenital cyanotic heart disease and noncyanotic heart disease, if the defects are large enough, children may show stunting of growth and are predisposed to frequent chest infections.

The four defects that comprise the tetralogy are

1. A large VSD
2. An obstruction of the outlet of the right ventricle that restricts the flow of blood into the pulmonary artery (see Fig. 4).

3. The entrance to the aorta overrides the right ventricular outlet and the large hole in the septum; thus, deoxygenated blood flows into the aorta and the systemic circulation to organs and tissues with cyanosis of the lips, mucous membranes, and the periphery
4. Right ventricular muscular wall enlargement

Additionally, these defects coexist in about 40% of patients with other cardiac defects including patent ductus arteriosus and peripheral pulmonary artery stenosis.

I. Clinical Features

The majority of children with tetralogy of Fallot are symptomatic and cyanotic. Most are observed to be cyanotic from birth or develop cyanosis before age 1 indicating severe pulmonary outflow obstruction and a large VSD. Severe shortness of breath on mild exertion, fatigue, and in some cases syncope that occasionally terminates in convulsions may occur. The child at rest often resorts to a squatting position or may lie with knees drawn to the chest, a most comfortable position that results in less cardiac burden.

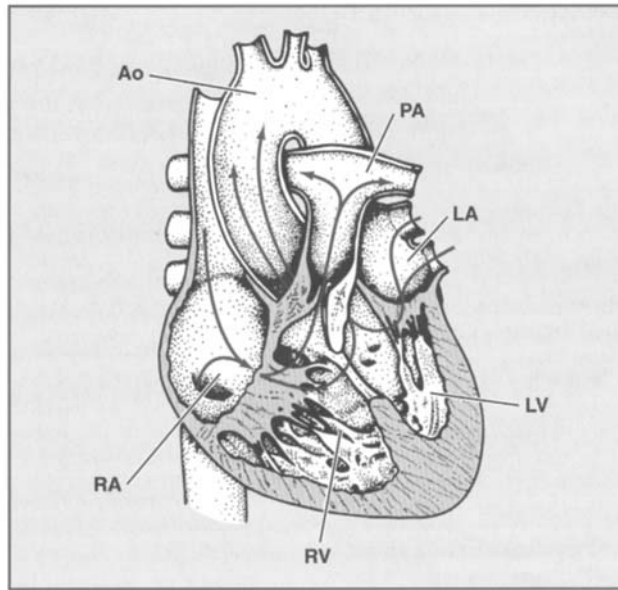

FIGURE 4 Tetralogy of fallot with infundibular and valvular pulmonic stenosis. The arrows indicate direction of blood flow. A substantial right-to-left shunt exists across the ventricular septal defect. RA = right atrium; LA = left atrium; RV = right ventricle; LV = left ventricle; Ao = aorta; PA = pulmonary artery. (From Friedman, W.F., and Silverman, M., in *Heart Disease, A Textbook of Cardiovascular Medicine*, sixth edition, Braunwald, E., Zipes, D.P., and Libby, P. Eds. Philadelphia: W.B. Saunders, 1559, 2001. With permission.)

On examination the infant reveals some underdevelopment. After one year the ends of the fingers have a curious clubbed shape and the toes may also be clubbed. A systolic thrill is palpable along with a loud systolic murmur heard along the lower left sternal border.

Echocardiography confirms diagnosis but delineation of complex pulmonary and other abnormalities usually require combined angiography and three-dimensional CT.

2. Management

Usually correction of the lesion is essential to prevent severe hypoxemia and delayed growth and development. Palliative measures are employed in infants and total correction is then carried out at low risk later in childhood.

IX. PREGNANCY AND CONGENITAL HEART DISEASE

Pregnancy should be avoided if possible in most patients with CHD. Patients with cyanotic CHD, Eisenmenger's syndrome, Marfan syndrome, coarctation of the aorta, VSD with shunt greater than 50% and others with right-to-left shunts, and moderate aortic stenosis must avoid pregnancy.

A. Research Implications

Because genetic causes of CHD are far more common than previously realized, there has recently been a vast amount of new genetic research. A single gene mutation appears to be the causative factor in familial forms of ASD. Much has been learned from the rubella syndrome in which abnormalities such as cataracts, deafness, microcephaly, patent ductus, pulmonary stenosis, and ASDs occur.

The genes responsible for many defects have been mapped and identified. Figure 5 gives cardiovascular manifestations associated with chromosome aberrations.

B. Teratogens

Teratogens and congenital heart disease require intensive research. The thalidomide effects are well-known, however, there are several drugs that have teratogenic effects and are used occasionally worldwide during the first 16 weeks of pregnancy. Many drugs including alcohol and other unknown substances are used within the first three weeks of pregnancy often before the mother is aware that pregnancy has occurred. Electrical impulses in the developing embryo produce a heart impulse as early as the 22nd day. During the first 28 days the developing fetus may be exposed to alcohol, antidepressants, caffeine, nicotine, and

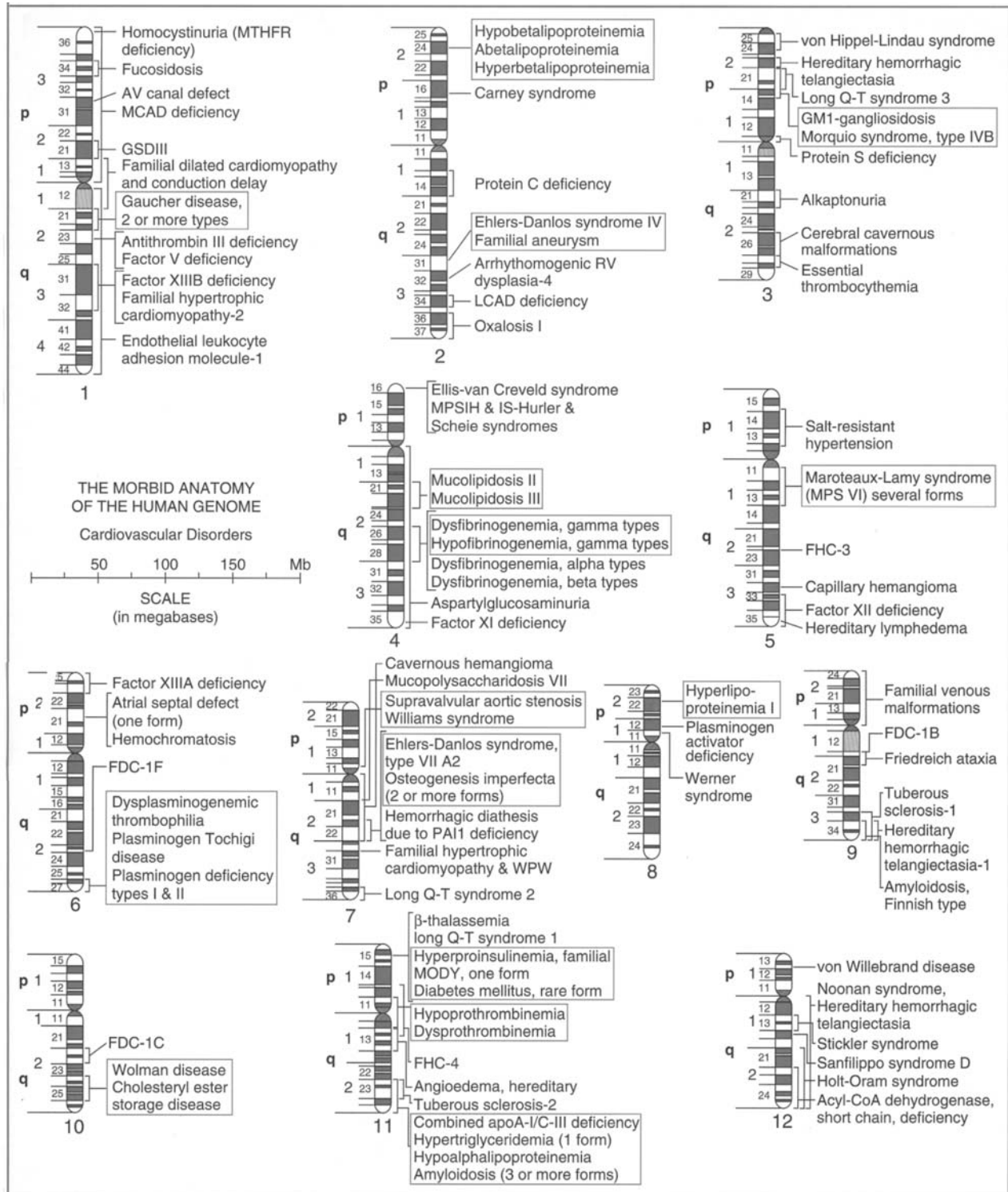

FIGURE 5 Chromosomal location of human genes associated with some disorders of the cardiovascular system. These genes affect the structure, function, and metabolism of the heart and blood vessels and hemostasis and have been identified by the deleterious effects of mutations. Numerous additional genes that encode structural proteins important to the cardiovascular system have been identified but not yet associated with disease. In the figure, brackets next to the chromosome show the regional localization of the gene causing a particular disorder. Brackets next to two or more disorders indicated that all the genes causing the disorders map to the same region. Disorders surrounded by boxes are caused by different mutations at the same gene. (From Pyeritz, R.E. (2001). *Heart Disease, 6th ed.*, Braunwald, E., Ed., Philadelphia: W.B. Saunders, pp. 1983–1984. With permission.)

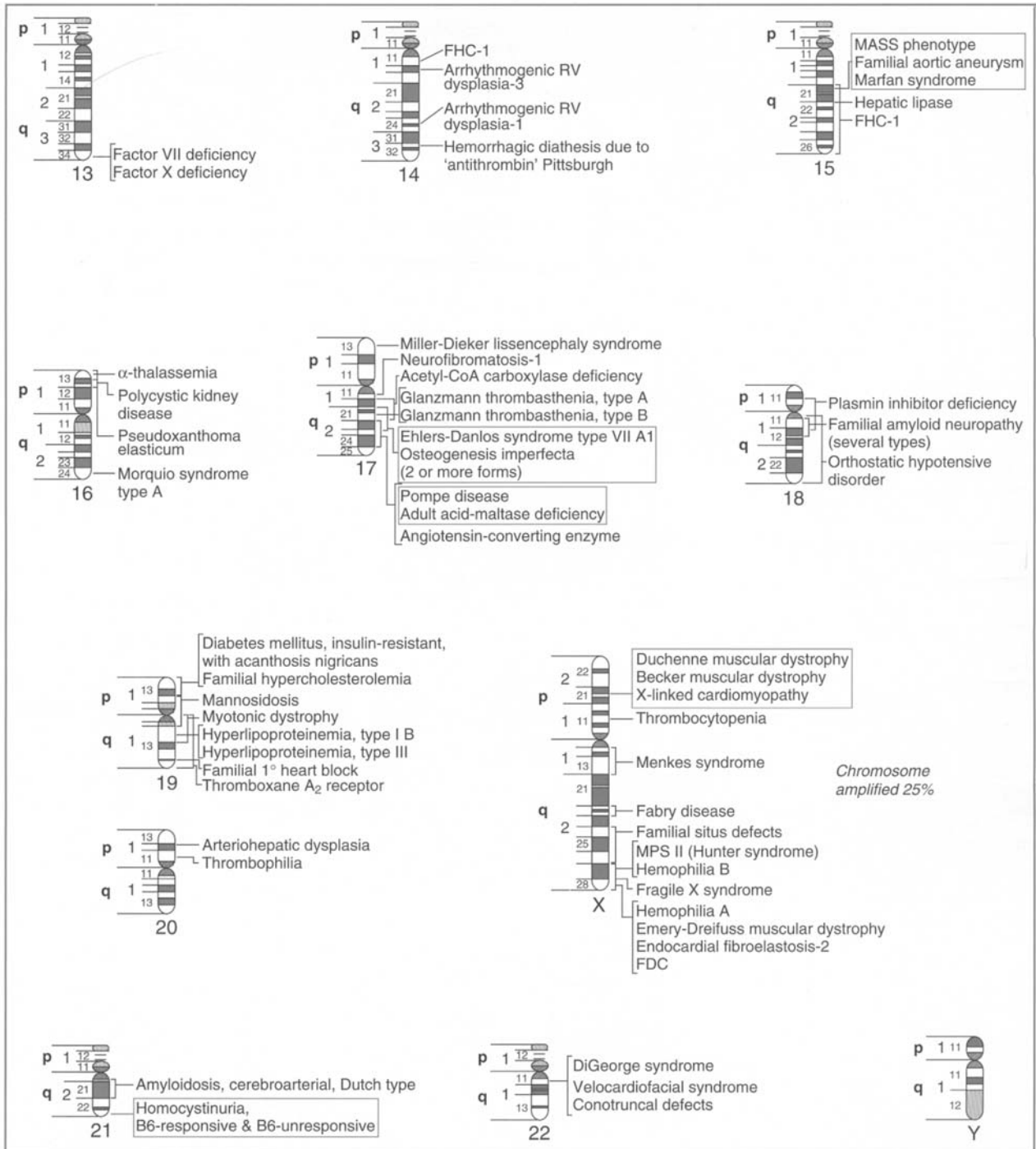

FIGURE 5 Continued

TABLE I
Cardiovascular Defects Associated with Prenatal Exposure to Teratogens

Teratogen	Cardiovascular Abnormalities ^a
Ethanol	~50% have CHD: VSD (~50% close spontaneously), TOF, ASD, ECD, absence of a pulmonary artery
Hydantoin	~10% have CHD: VSD, ASD, PS
Lithium	<3% have Ebstein anomaly
Phenylalanine	~20% have CHD: TOF
Retinoic acid	>50% have CHD: TGA, TOF, VSD, IAA
Rubella	>50% have CHD: PDA with or without ASD, VSD, PPS, IAA
Trimethadione	~50% have CHD: complex combinations most frequent (involving VSD, ASD, PDA, AS, PS), VSD, TOF
Valproic acid	>50% have CHD: left- and right-sided flow lesions: CoA, HLH, ASD, VSD, pulmonary atresia
Vitamin D	Supravalvular aortic stenosis is the cardinal manifestation; PPS
Walfarin	~10% have CHD: PDA, PS; rarely, intracranial hemorrhage.

CHD = congenital heart defect(s); VSD = ventricular septal defect; TOF = tetralogy of Fallot; ASD = atrial septal defect; ECD = endocardial cushion defect; PS = valvular pulmonic stenosis; TGA = transposition of great arteries; IAA = interrupted aortic arch; PPS = peripheral pulmonic stenosis; PDA = patent ductus arteriosus; AS = aortic stenosis; CoA = coarctation of aorta; HLH = hypoplastic left heart.

^aAmong patients with the full clinical spectrum associated with each teratogen; cardiovascular defects listed in decreasing order of prevalence. From Pyeritz, R.E. (2001). Genetics and cardiovascular disease. In Braunwald, E., Zipes, D. P., and Libby, P., Eds., *Heart Disease, 6th ed.*, Philadelphia: W.B. Saunders, p.1993.

other products that may alter the development of the unique human heart. The study of the embryo heart at weeks 2 through 8 is crucial and more research is needed in this area (see the chapter Embryology).

More than strict animal testing of new and old drugs that may be teratogenic must be done. It is necessary to determine which animals are the best representation of the human fetus. Development of the chick embryo is similar to that of the human embryo and much of our understanding of the heart's early development comes from studies of chick embryo. Perhaps a different model is required to test the effect substances on developmental injury in the human embryo.

Cardiovascular anomalies associated with prenatal exposure to teratogens are given in Table 1. Cardiovascular drugs that are contraindicated particularly during the first 16 weeks of pregnancy include angiotensin-converting enzyme (ACE) inhibitors and angiotensin receptor blockers. These agents may adversely affect fetal and neonatal blood pressure control and renal function. They may cause defects and oligohydramnios. These agents are teratogenic in animals and are associated with a high incidence of intrauterine death. They are used in

the management of hypertension and are contraindicated in women of childbearing age. Calcium antagonists such as diltiazem, verapamil, nifedipine, amlodipine, and similar dihydropyridines must also be avoided.

BIBLIOGRAPHY

- Fawzy, M. E., Awad, M., Hassan, W. et al. Long-term outcome (up to 15 years) of balloon angioplasty of discrete native coarctation of the aorta in adolescents and adults. *J. Am. Coll. Cardiol.*, 43:1062-1067, 2004.
- Fleetwood, I. G., and Steinberg, G. K. Arteriovenous malformations. *Lancet*, 359:863-73, 2002.
- Gabriel, H. M., Heger, M., Innerhofer, P. et al. Long-term outcome of patients with ventricular septal defect considered not to require surgical closure during childhood. *J. Am. Coll. Cardiol.*, 59:1066-71, 2002.
- Hoffman, J. I. E., and Kaplan, S. The incidence of congenital heart disease. *J. Am. Coll. Cardiol.*, 39:1890-900, 2002.
- Lim, M. J., Forsberg, M., and Kern, M. J. Provocable pressure gradient across an anomalous left main coronary artery: A unique diagnostic tool. *Circulation*, 111:e108-e109, 2005.
- Taylor, A. J., and Virmani, R. Coronary artery anomalies in adults: Which are high-risk? *AAC Curr. J. Rev.*, September/Oct 1992-95, 2001.

Contraception and Cardiovascular Disease

I. Oral Contraceptives

GLOSSARY

embolism sudden blocking of an artery by a clot or foreign material which has been brought to its site of lodgement by the circulating blood. Pulmonary embolism is often caused by a clot (thrombus) that dislodges from a vein in the thigh or pelvis and shoots into a pulmonary artery.

myocardial infarction death of an area of heart muscle due to blockage of the coronary artery by blood clot and atheroma; medical term for a heart attack or coronary thrombosis.

thromboembolism formation of a blood clot and a subsequent dislodgment; the thrombus is carried in the circulating blood and obstructs an artery.

I. ORAL CONTRACEPTIVES

A. Risks

The risk of cardiovascular disease among women attributed to the use of oral contraceptives became immediately apparent following the use of these agents more than 40 years ago. The risk was alarming in women older than age 30 who smoked cigarettes. The use of third generation oral contraceptives is purported to have a lower risk of myocardial infarction compared with second generation oral contraceptives. Recent studies do not indicate that third generation contraceptives possess a lower risk for infarction and most important, the studies indicate a significantly increased risk for deep vein thrombosis (DVT) and pulmonary embolism compared with users of second generation contraceptives. Because the risk for myocardial infarction in women before age 35 is extremely low, studies are confounded.

The risk of heart attack has not been minimized by the use of third generation oral contraceptives. Cigarette smoking continues to be the major factor for increased risk

of heart attacks in older, childbearing women aged 33–45 and second or third generation contraceptives increase that risk. Most important, the increased risk for DVT and thromboembolism has not been removed.

I. Increased Coagulation Factors

The identification of a poor anticoagulant response to activate protein C (aPC) has far reaching consequences and has provoked new directions in the field of prothrombotic markers. Individuals with aPC resistance have inadequate partial thromboplastin time (PTT) prolongation which increases hypercoagulability. The PTT gives a measure of clotting factors except the factor caused by prothrombin. Normal levels of PTT range from 30 to 40 seconds. When heparin, the well-known intravenous anticoagulant, is administered to thin the blood the PTT goal is set at 1.5–2.3 times the mean control range, which corresponds to a PTT of 50–80 seconds. At these levels some clots are partly dissolved and further clotting is prevented.

Most important, aPC resistance occurs more frequently with DVT as seen from two studies. This incidence is considerably higher than that observed with well-known coagulation protein deficiencies which include protein C at 3%, protein S at 4%, antithrombin at 2%, and plasminogen at 1%.

Normally, a specific amount of aPC added to plasma causes a calculated prolongation of the PTT, but in patients with aPC resistance inadequate PTT prolongation is observed.

The factor V Leiden mutation is an important risk for DVT. In a case control study of premenopausal women who developed DVT, the risk of thrombosis among users of oral contraceptives was increased fourfold. The risk for DVT was eightfold among carriers of the factor V Leiden versus noncarriers. Women with the factor V Leiden mutation who used oral contraceptives had a 30-fold increase in risk.

2. Deep Vein Thrombosis

The phenotype of aPC resistance is associated with a single point mutation, designated factor V Leiden in the factor V gene. Factor V Leiden mutation results from a single nucleotide substitution of adenine for guanine 1691. Thus, the amino acid arginine is replaced with glutamine at position 506. This unfortunate change eliminates the protein C cleavage site in factor V. The frequency of this mutation was found to be about 3% in healthy male physicians in the United States and did not appear to increase the risk of stroke or heart attack in the Physicians Health Study. But the incidence of the factor V mutation was observed to be three times higher among men who developed DVT. Thus coagulation and clotting in veins of the lower limbs and pelvis and veins that drain into the right atrium is a different phenomenon from that observed in the coronary arteries supplying the heart with blood and the branches of the aorta that circulate blood to the head and lower limbs. A good example is set forth by the proved fact that aspirin and other antiplatelet agents are useful in preventing clots in the coronary arteries and in the prevention of strokes, but they are of little or no value in the prevention of clot formation in the veins of the lower limbs.

Thus it is advisable to screen for factor V Leiden in women older than age 35 who take oral contraceptives. This advice is particularly important if there is concomitant hypertension, hyperlipidemia, cigarette smoking, or a family history of DVT.

3. Myocardial Infarction

Second and third generation oral contraceptives generally contain a small dose of synthetic estrogen and a synthetic progestin. The risk of myocardial infarction is currently believed to be low, but the risk is increased in women older than age 35 and in those with hypertension, hyperlipidemia, and in those who are cigarette smokers.

The estrogenic contents of the pill modestly increases good cholesterol HDL levels, lowers LDL cholesterol (bad) levels, and mildly increases serum triglycerides. The progestin component increases LDL levels, causes a decrease in HDL levels, and may increase coagulopathy. Agents such as desogestrel, gestodene, norgestimate, and norethindrone may have modest beneficial effects on lipoprotein levels, but they are associated with an increase in DVT and thromboembolism which includes pulmonary embolism.

4. Hypertension

Although second and third generation oral contraceptives rarely cause an increase in blood pressure in younger women, in those over 35 a mild increase in blood pressure that returns to normal has been observed. The incidence of increased blood pressure is low, but it is increased in individuals who are overweight or who have had hypertension in previous pregnancies, and perhaps in those who abuse alcohol. In rare instances blood pressure may accelerate rapidly and cause renal damage. Thus, caution is necessary and adequate follow up is essential. In addition, plasma insulin levels are increased reflecting peripheral insulin resistance, a harbinger for subtle cardiovascular damage.

a. Clinical Study: Tanis et al.

Methods: This study consisted of 248 women who had a first myocardial infarction and were identified and enrolled in a nationwide population-based case control study and 925 control women who had not had a heart attack and who were matched for age and calendar year of the index event. Subjects supplied information on all contraceptive use and cardiovascular risk factors.

Results: The alteration for heart attack among women who used any type of combined oral contraceptive as compared with nonusers was 2.0. The adjusted alteration was 2.5 among women who used second generation and 1.3 among those who used third generation oral contraceptives.

Conclusions: The authors of the study concluded:

“the risk of myocardial infarction was increased among women who used second generation oral contraceptives. Results with respect to use of third generation oral contraceptives were inconclusive but suggested that the risk was lower than the risk associated with second generation oral contraceptives.”

B. Perspective

Although the majority of patients with a heart attack in the study quoted above were between the age of 35 and 49 (~72%), only 74 patients with acute myocardial infarction were using oral contraceptives and 134 were not. The wide confidence interval observed in the study highlights the low statistical power of the study and

indicates that random variation is an alternative explanation for the results. It is interesting that the authors of the study offered the following rebuttals to criticisms of the study:

“The lower risk of myocardial infarction that we observed in association with third generation contraceptives (desogestrel or gestodene) as compared with second generation contraceptives (levonorgestrel) may be explained by random variation around equivalence, also, the study performed in the United Kingdom found the risk associated with third generation contraceptives was 1.8 times that associated with secondary generation contraceptives.”

Combined results of the two studies suggest:

third generation contraceptives increase the risk of myocardial infarction, and the difference in second generation contraceptives, if any, is small. Third generation contraceptives double the risk of venous thrombosis associated with second generation contraceptives which are already associated with a fourfold increase in risk relative to non-use of oral contraceptives.

Tanis and Rosendaal agreed with my admonitions given above and further stated that “there are prothrombotic,

hemostatic changes that are more pronounced with third generation preparations than with older preparations.”

Clearly this study is too small to generate credible answers for individuals who may be at risk and most important, policymaking remains at a standstill.

On the basis of several studies that were in progress in 1995, the British committee on safety of medicines warned general practitioners of a potentially increased risk of venous thromboembolism among users of third generation contraceptives. This advice was not given in the United States. Policymakers must be warned that they must differentiate the risk for myocardial infarction that is totally different from thromboembolism caused by DVT. Complications from DVT are as important as myocardial infarction because they may cause life-threatening pulmonary embolism.

BIBLIOGRAPHY

- Chasan-Taber L., and Stampfer, M. Oral contraceptives and myocardial infarction — the search for the smoking gun. *N. Engl. J. Med.*, 345:1841–2, 2001.
- Tanis, B. C., and Rosendaal, F. R. Oral contraceptives and the risk of myocardial infarction. *N. Engl. J. Med.*, 346:1828, 2002.
- Tanis, B. C., van den Bosch, M. A. J., Kemmeren, J. M. et al. Oral contraceptives and the risk of myocardial infarction. *N. Engl. J. Med.*, 345:1787–93, 2001.
- Vessey, M., Painter, R., and Yeates, D. Mortality in relation to oral contraceptive use and cigarette smoking. *Lancet*, 362:185–91, 2003.

Coronary Artery Bypass Surgery

- I. The Coronary Arteries
- II. Indications
- III. Types of Grafts
- IV. Outcomes
- V. Complications
- VI. Surgery in the Elderly
- VII. Contraindications
- VIII. Medications
- IX. Coronary Bypass Surgery versus PCI

GLOSSARY

angina chest pain caused by temporary lack of blood to an area of heart muscle cells, usually caused by severe obstruction of the artery supplying blood to the segment of the cells.

atheroma same as atherosclerosis, raised plaques filled with cholesterol, calcium, and other substances on the inner wall of arteries that obstruct the lumen and the flow of blood; the plaque of atheroma hardens the artery, hence the term atherosclerosis (sclerosis = hardening).

atrial fibrillation the most common, persistent arrhythmia that is seen in medical practice; it may precipitate thromboembolic stroke.

ejection fraction the fraction of blood ejected from the heart into the arteries, normally this ranges from 60 to 75%; a low ejection fraction is less than 40%; often used as a marker of left ventricular contractility.

embolism, embolus a blood clot that forms in an artery, a vein, or the heart that breaks off and is carried by the circulating blood, finally lodging and blocking the artery that supplies an organ with blood; for example, pulmonary embolism is an embolus blocking the artery in the lung.

heart failure failure of the heart to pump sufficient blood from the chambers into the aorta; inadequate supply of blood reaches organs and tissues.

myocardial infarction death of an area of heart muscle due to blockage of a coronary artery by blood clot and atheroma; medical term for a heart attack or coronary thrombosis.

I. THE CORONARY ARTERIES

Dr. Rene Favoloro of Argentina performed the first coronary artery bypass graft (CABG) in 1967 at the Cleveland Clinic. He used a vein from a patient's leg to bypass the obstruction in the coronary artery. Since that time, several million bypass operations have been performed worldwide.

Coronary artery bypass grafting is a simple procedure: A vein from the patient's leg is removed and inserted into the aorta as it leaves the heart and the other end of the vein is joined to the coronary artery below the blockage. Blood then flows from the aorta through the vein graft beyond the blockage to the coronary artery and to the heart muscle (see Fig. 1). When possible, surgeons prefer to use the internal mammary artery instead of using a vein graft to bypass the blockage in the important left anterior descending (LAD) artery.

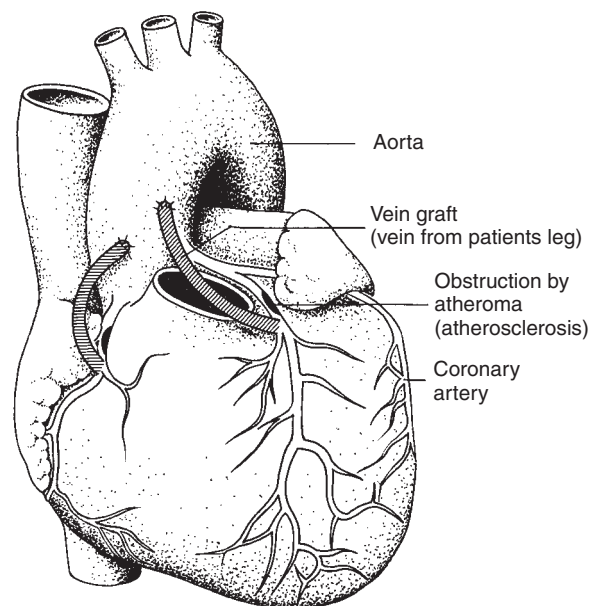

FIGURE 1 Coronary bypass graft. Blood flows from the aorta to a coronary artery bypassing the blockage.

II. INDICATIONS

A. Stable Angina

If stable angina is not adequately relieved by the combination of a beta-blocker, a nitrate, and a calcium blocker and lifestyle is deemed unacceptable by the patient or the physician, coronary artery bypass surgery is usually recommended. The main aim of surgery is to relieve pain. The complete relief of pain is certainly most satisfying and this is achieved in 90% of patients, whereas drugs achieve this goal in less than 50%. Drugs lessen the frequency of angina by about 60% in approximately 60% of patients treated. Some patients are satisfied with medical therapy and surgery is not indicated. About 40% of patients with angina are not satisfactorily controlled with medical therapy; these patients are recommended to have coronary arteriography with a view to CABG.

Patients with mild anginal symptoms may have severe atheromatous obstruction of the coronary arteries. Stress testing and nuclear scans may risk-stratify these patients; those with positive tests at a workload that is low are usually submitted to coronary arteriography.

Patients with mild stable angina with compromised left ventricular function as indicated by an ejection fraction (EF) of less than 45% and patients with diabetes may obtain improvement in survival with a revascularization procedure. The revascularization procedure may be bypass surgery or PCI. In addition, beta-blockers are contraindicated in patients with asthma and they may require revascularization at an early stage.

B. Unstable Angina

Patients with unstable angina are identified by the following: a change in pattern, increasing frequency, severity and/or duration of pain, and a lesser degree of known precipitating factors. Pain may occur on exertion and at rest. Also, new onset of angina present for less than 60 days is classified as unstable angina.

The majority of patients with unstable angina should undergo coronary arteriography. Depending on the extent and site of lesions, they are offered PCI or surgery if no major contraindication exists.

C. Left Main Coronary Artery Disease

The left main coronary artery is a short segment before it divides into the LAD and circumflex arteries (see Fig. 2). Severe disease of the left main is fortunately uncommon

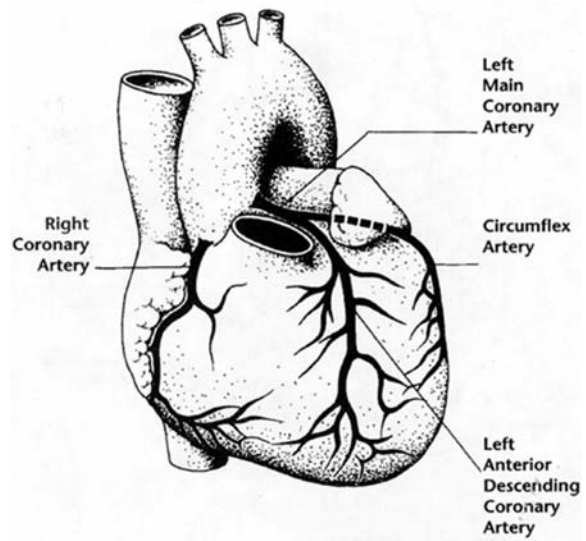

FIGURE 2 Coronary arteries.

but is obviously a serious situation when it occurs, because it supplies blood to most of the heart. Thus, CABG is advisable regardless of the severity of symptoms or left ventricular dysfunction. Patients with triple-vessel disease which includes atheromatous obstruction of the proximal LAD are at high risk for coronary events and bypass surgery is usually recommended.

D. Diabetes Mellitus

Patients with diabetes and stable or unstable angina with triple- or double-vessel disease, especially if this involves the LAD, are usually offered surgery because its benefits supersede those of PCI.

III. TYPES OF GRAFTS

A. Saphenous Vein

The saphenous vein is ideal for bypass of occlusions of the right coronary and circumflex coronary arteries and for their diagonal branches. A saphenous vein graft is easily harvested and is used in emergency situations. These include bypass of the LAD because the internal mammary artery is more difficult to mobilize in emergency situations. Saphenous vein grafts are superior or equal to radial artery grafts, but are much more vulnerable to occlusion compared with the internal mammary artery.

Approximately 10% of saphenous grafts become obstructed during the perioperative period. At 1 year approximately 22% are obstructed and at 5 and 10 years, approximately 30% and greater than 55%, respectively, of these grafts become occluded. During the first year after implantation of the vein graft, there is proliferation and migration of smooth muscle cell into the intima. The migration of smooth muscle cells is nature's method of healing and strengthening damaged vascular endothelium and is an early stage of atheromatous formation. In these lesions there are lipid-laden foam cells, cholesterol clefts, and areas of calcification and thrombosis that are features of atherosclerosis. Late occlusions are due to accelerated atherosclerosis that occurs in saphenous vein grafts. The saphenous vein in the leg never develops atherosclerosis and the atheromatous process occurs only after the graft is exposed to the high arterial pressure that is present in the coronary and systemic circulation; the low pulsatile pressure in veins protects the vessel from the development of atherosclerosis. Beta-blocking agents decrease cardiac ejection velocity and pulsatile blood flow, and along with marked blood LDL cholesterol reduction, may favorably influence saphenous vein graft occlusion. Fortunately, atherosclerosis is rare in internal mammary artery grafts.

B. Internal Mammary Artery

Since the late seventies use of internal mammary artery grafts became popular and the current standard for bypass grafting is the routine use of the left internal mammary artery graft to the LAD, with supplemental saphenous vein grafts to other arteries. Figure 1 shows saphenous vein grafts and Fig. 2 shows an internal mammary artery graft to the LAD.

It is not known why the internal mammary artery rarely develops atheroma. It is one of the few arteries in the body that is relatively free from atheromatous obstruction except after age 70. The endothelium of this artery produces more of the vasodilator prostacyclin than the endothelium of the saphenous vein. This is one explanation that is given for the differences in atheroma formation.

Fibrointimal proliferation that is different from atheroma formation rarely develops in internal mammary artery grafts resulting in late graft closure. But a greater than 80% patency at 10 years provides a decreased risk of late death, myocardial infarction, and reoperation over a 20-year period. Patency rates are 95, 90, and 83% at 1, 5, and 10 years, respectively.

The internal mammary artery is, however, delicate and great care is required during mobilization to avoid

trauma to the vessel. Because the procedure takes considerable time, this graft is not often used for emergency surgery. The use of bilateral internal mammary artery grafts provides superior protection from long-term occurrence of myocardial infarction and angina, but harvesting is time-consuming and causes a high rate of postoperative complications such as bleeding, wound infection, and prolonged ventilatory support. Bilateral internal mammary grafting is not an acceptable choice for diabetics because of the increased occurrence of sternal wound infections.

C. Radial Artery

The radial artery is readily accessible in the forearm, and it is used frequently by some surgeons. Spasm and thrombosis of the artery have been minimized by careful manipulation of the vessel and the use of long-term calcium antagonists. The patency rate for radial grafts at 5 years is approximately 80% versus 90% for internal mammary artery graft. Khot et al. have recently shown that radial artery bypass grafts have an increased occurrence of angiographically severe stenosis and occlusion compared with left internal mammary arteries and saphenous vein grafts.

When coronary artery bypass surgery is selected, patients who can receive an internal mammary artery graft are most fortunate. The arterial graft has a prolonged patency of 15–20 years versus approximately 10–12 years for saphenous vein grafts.

D. Robotic Bypass Surgery

Robotic coronary bypass surgery using a left internal mammary artery graft to the LAD along with balloon angioplasty and stenting to non-LAD vessels that require treatment has proven successful in a small study of 150 patients. Follow up after three years shows 100% of the mammary grafts to be patent; 3.8% of the PCI vessels were occluded, and 15% were narrowed; 10 patients had repeat PCI, and none had repeat surgery. Importantly, 96% of the patients treated with this hybrid procedure were free of symptoms at three years. Because the gold standard treatment for obstructive coronary artery disease remains a left internal mammary artery graft, there is hope that this hybrid procedure using robotic bypass surgery to the LAD and angioplasty with stent for other vessels could prove a major management strategy for the relief of symptomatic, obstructive coronary artery disease.

IV. OUTCOMES

A. Survival

Overall mortality of bypass surgery is approximately 3%. The operative mortality in patients over age 70, especially in women, is high — 6.3% versus 3.8% for men. Low-risk patients may have a mortality as low as 1%, but in patients with left ventricular dysfunction and an EF of 30% or less, mortality is as high as 9%. Survival at one month and 1, 5, 10, and 15 years is 97, 95, 87, 76, and 60%, respectively (see Table 1).

B. Prolongation of Life

Improved survival may be achieved in patients with stable or unstable angina and serious blockage of arteries in the following types:

1. Individuals who have severe narrowing of the left main coronary artery before it divides; this is the anatomical lesion for which surgery is universally accepted and is fortunately rare
2. Individuals who have triple-vessel disease, that is, severe obstruction of the right coronary, the LAD, and the circumflex arteries, especially in patients with decreased function of the left ventricular muscle
3. If the LAD is blocked before its first branch, plus two other vessels have more than 80% obstruction and angioplasty is not possible
4. Left ventricular dysfunction

The EF, the amount of blood the ventricle puts out into the aorta with each beat, is an important measure of the strength of the heart muscle. Its value is expressed as a percentage. A normal EF is more than 50%, an EF of less than 30% carries a bad prognosis, and less than 25% is a very poor prognosis. Surgery is highly beneficial in patients with an EF between 30 and 45%. Therefore patients with triple- or double-vessel disease that includes the LAD and left ventricular dysfunction are best managed with bypass surgery rather than angioplasty with stent or medical therapy.

Some studies indicate that viable dysfunction in the myocardium may improve after coronary revascularization. Although bypass surgery in patients with left ventricular dysfunction may provide relief of angina and improve left ventricular function in some. There is lack of evidence from randomized controlled trials and the mortality of surgery should not be underestimated. An EF of less than 35% predicts an operative mortality of approximately 7%; a recent study in patients with an EF of less than 30% showed an in-hospital operative mortality of 8.4%. A recent study with the beta-blocking agent carvedilol demonstrated improvement in symptoms, occurrence of heart failure, and survival in patients with myocardial infarction and depressed left ventricular function.

Most important, the aforementioned clinical trials of bypass surgery in patients with left ventricular dysfunction did not compare patients medically treated with a drug as effective as carvedilol. The recent CAPRICORN and COPERNICUS studies show conclusively that the beta-blocker carvedilol improves survival in patients with

TABLE I
Results and Complications of Coronary Artery Bypass Surgery

Occurrence	1 Week (%)	1 Year (%)	5 Years (%)	10 Years (%)	15 Years (%)
Survival (vein graft)	99	95	87	76	60 ^a –69 ^d
Perioperative myocardial infarction (MI)	7–12				
MI fatal, nonfatal			5	15	35
Reoperation for bleeding	1–4				
Occlusion					
Vein graft occlusion	6–10 ^b	12–20 ^b	30	50–55	>60
Internal mammary graft				17	
Internal mammary anastomosis ^c				17	
Symptomatic improvement	90	80			
Asymptomatic angina free	90		50		

^aACC/AHA Task Force Report, *J Am Coll Cardiol*, 1991; 17:543.

^bAspirin 1 hour postoperative = 1.6 and 5.8% (see Table 4.12.)

^cPreferred technique.

^dInternal mammary graft, *J Am Coll Cardiol*, 1996; 334:216.

coronary artery disease and severe left ventricular dysfunction with an EF of less than 30%; (see these studies given in the Bibliography).

C. Symptomatic Relief

Approximately 90% of patients get complete relief of angina for the first year after saphenous vein grafts. At the end of 5 years approximately 30% of patients have obstruction of their grafts and in some patients angina recurs. The approximate freedom from angina is 80% at 5 years and 50 and 25% at 10 and 15 years, respectively.

Presently, with the addition of medication such as aspirin, fewer grafts become blocked. After five years, about 80% of patients are still pain-free, lead active lives, and enjoy life to the fullest — a situation that does not materialize with the use of drug treatment in patients with frequent episodes of angina.

Bypass surgery is simple to perform and there are few complications. Cardiac surgeons can be proud of this operation, which provides major relief for suffering and can prolong life in a selected few. We can visualize many successful operations using angioplasty, stents, and laser therapy during the next 20 years, but unless atherosclerosis is prevented, and this seems to be out of reach for the next 50 years, coronary artery bypass surgery will play a substantial role for longer than some experts predict. Bypass surgery will be necessary for the left main coronary artery disease and triple-vessel disease with left ventricular dysfunction that generally cannot be treated with angioplasty and stent.

Patients who have had surgery must understand, however, that the other arteries and points in the coronary artery below the graft can develop further atherosclerosis because the operation does not cure the disease. In addition, a blood clot (coronary thrombosis) can form in any individual at any time at the site of atheromatous obstruction without warning. Therefore, coronary bypass surgery does not prevent a second or third heart attack, although it may prevent death in a few.

D. Other Factors Affecting Mortality and Morbidity

Approximately 50% of grafts become blocked after 10 years, particularly in patients who smoke or have hypertension, diabetes, or an LDL cholesterol level greater than 120 mg/dl (3 mmol/L). Thus most patients require treatment with statins to achieve an LDL goal of less than 80 mg/dl (2.0 mmol/L) to maintain patency of grafts

which provides relief from angina. Discontinuation of smoking is necessary to prevent the recurrence of angina and improvement in survival.

V. COMPLICATIONS

A. Acute Myocardial Infarction

Although intraoperative myocardial protection with improvements in surgical techniques has advanced during the past decade, perioperative myocardial infarction (listed in Table 1) occurs in 7–12% of patients. Causes of perioperative myocardial infarction include incomplete revascularization, thrombosis of the native coronary artery, diffuse atheromatous formation of the coronary artery distal to the bypass graft, technical problems with the surgical anastomosis, inadequate myocardial preservation intraoperatively, increased myocardial oxygen needs during surgery, hypotension caused by bleeding or medications, and tachycardia and abnormal heart rhythms such as atrial fibrillation that increase myocardial oxygen demand.

The diagnosis of perioperative myocardial infarction is difficult because there is virtually always elevation of myocardial creatine kinase (CK-MB) following surgery; nonspecific ECG changes occur postoperatively and these important diagnostic tests of acute myocardial infarction become nondiagnostic. The ECG still remains the most useful test, however, for diagnosis of perioperative infarction. The presence of new Q waves accompanied by evolutionary ST or T-wave changes should suggest infarction.

Bedside echocardiography may reveal new regional wall motion abnormalities compared with the preoperative baseline echocardiogram. The new sensitive cardiac enzymes, troponins, are not useful because these enzymes become elevated postoperatively in virtually all patients who undergo bypass surgery.

A perioperative infarction increases in-hospital mortality (12%) when compared with patients who have not sustained infarction (mortality is approximately 2%). Predictors of perioperative infarction include left main coronary artery disease; three-vessel disease, and perioperative angina.

B. Heart Failure

Heart failure may be precipitated in patients with left ventricular dysfunction, especially in those with an EF of less than 30%. Arrhythmias with a fast ventricular rate such as atrial fibrillation and other supraventricular

arrhythmias occur during surgery and in the early postoperative state. These tachycardias increase left ventricle work and strain that may precipitate heart failure. The avoidance of drugs that depress cardiac contractility such as calcium antagonists, the use of ACE inhibitors for the left ventricular strain, and the judicious use of small doses of beta-blocking agents provide benefits. Furosemide as well as other diuretic agents are used to relieve shortness of breath.

C. Atrial Fibrillation and Other Arrhythmias

Atrial fibrillation is a common complication of bypass surgery and occurs in approximately 40% of patients, mainly within the first three days of surgery. Atrial fibrillation increases the incidence of heart failure; a thrombus may form in the left atrium and embolization may result in stroke. It is remarkable that although atrial fibrillation is an extremely common arrhythmia precipitated by cardiac surgery, management strategies that can significantly prevent its occurrence have not been established.

The pre- and perioperative administration of beta-adrenergic blocking agents reduce the incidence of heart failure to about 30% in patients following bypass surgery and in approximately 50% of patients following valvular surgery. When atrial fibrillation occurs during surgery the administration of intravenous beta-blocking agents such as metoprolol or esmolol reduces the fast ventricular rate from greater than 130 beats per minute to less than 90 beats per minute.

Supraventricular tachycardia occurs infrequently. This responds rapidly to intravenous administration of adenosine 6 mg in more than 60% of patients. A repeated dose of 12 mg can be administered if necessary and this terminates the tachycardia in virtually all patients. Ventricular arrhythmias such as ventricular premature beats occur frequently and when needed are managed with a small doses of a beta-blocking agent.

D. Neurologic

Neurologic complications occur in approximately 6% of bypass patients. Confusional state, stupor, coma, and some deterioration in intellectual function and memory may occur, albeit rarely. Intellectual dysfunction in the early postoperative period occurs in greater than 50% of patients. Causes of neurological defects include embolization of mobile atherosclerotic plaques in the aorta. Intraoperative manipulation of the aorta is a major cause of atheroemboli. Emboli from the cardiopulmonary bypass

machine circuit and its tubing can also cause neurological defects. Cardiac surgery carried out on the beating heart with the avoidance of cardiopulmonary bypass largely overcomes these defects and its use is being developed.

E. Bleeding

Reoperation for hemorrhage is needed in approximately 3% of bypass patients. The risk of bleeding is increased in the elderly and also during bilateral internal mammary artery grafting. The preoperative use of aspirin, heparin, and platelet receptor blockers in the management of acute coronary syndromes increases the risk for hemorrhage.

F. Infection

Mediastinitis and/or infection of the wound with dehiscence occurs in about 1% of patients. This is increased in obese individuals, diabetics, or with the use of bilateral internal mammary artery grafts.

G. Hypertension

Postoperative hypertension occurs in approximately 50% of patients and is easily controlled with nitroprusside, intravenous nitroglycerin, beta-blocking agents, or calcium antagonists.

VI. SURGERY IN THE ELDERLY

Surgery in relatively healthy patients between the age of 70 to 80 in the absence of diabetes, left ventricular dysfunction, and other cardiovascular atherothrombotic disease undergo bypass surgery with a small added risk compared to younger patients. In a large series of patients intraoperative mortality was 3.8% in men versus 6.2% in women. The presence of the above conditions and other comorbid conditions increases the risk considerably to more than 7%.

A. Octogenarian Study

Study question: Is there a difference in outcomes among octogenarians undergoing bypass surgery using cardiopulmonary bypass or surgery without cardiopulmonary bypass.

Methods: Bypass surgery was performed in patients 80 years or older using cardiopulmonary bypass in 63 and 62 surgeries were without cardiopulmonary bypass. Baseline left ventricular EF and comorbidity were similar in the groups preoperatively and the mean number of grafts in patients did not differ.

Results: The operative mortality was higher in the cardiopulmonary bypass group, 15.9 versus 4.8% in those without bypass ($P=0.04$). More patients in the cardiopulmonary bypass group required blood transfusion, 92% versus 73% ($p=0.01$). Postoperative myocardial infarction was similar, 11% versus 15%. This remarkable study should prompt a large randomized trial to confirm the results.

VII. CONTRAINDICATIONS

Severe damage to the heart muscle as manifested by recurrent heart failure or other indications of left ventricular dysfunction and an EF of less than 30% is a major contraindication for bypass graft surgery. Such patients are very short of breath and often have fluid in the lungs. Shortness of breath cannot be relieved by surgery, and the heart muscle is not significantly strengthened for surgery.

Several heart attacks cause large areas of scarring, and the scar tissue is weak. Scar tissue is dead and not supplied with blood; therefore, a bypass graft does not feed blood to that area. Heart failure in the presence of an acute heart attack that clears within the first seven days is not a contraindication to bypass surgery several months later, because the heart muscle recovers more than 75% of its function.

VIII. MEDICATIONS

A. Perioperative

1. Aspirin

Aspirin given perioperatively has been shown to reduce graft occlusion.

2. Beta-Adrenergic Blockers

Beta-blockers have been shown to decrease morbidity and mortality following cardiac surgery and other forms of surgery. These agents quell the effects of catecholamines and allow safer induction of anesthesia and help to prevent the hypertensive response to endotracheal intubation. They also prevent recurrent arrhythmias and have been shown to improve morbidity and mortality. Atenolol has been shown in a randomized controlled trial to reduce morbidity and mortality when given before operation and one week postoperatively. In a randomized controlled trial of 1351 high-risk patients undergoing vascular surgery, bisoprolol significantly reduced events ($P < 0.001$). Bisoprolol was commenced one week preoperatively and continued

for 30 days postoperatively. There were two deaths and no myocardial infarctions versus nine deaths and nine infarctions in the untreated group.

B. Postoperative Maintenance

Maintenance medications that are given after coronary bypass surgery include aspirin, beta-adrenergic blockers, statins, and calcium antagonists.

1. Aspirin

Coated aspirin 325 mg daily is given to patients indefinitely to prevent graft occlusion and to prevent recurrent fatal or nonfatal myocardial infarction.

2. Beta-Adrenergic Blockers

These are recommended in virtually all patients unless contraindicated by the presence of asthma or significant bradycardia with a heart rate less than 50 beats per minute. These agents assist with maintenance of blood pressure in the normal range, decrease cardiac ejection velocity, prevent tachycardia, and are known to prevent fatal or nonfatal myocardial infarctions and sudden death in patients with coronary artery disease.

3. Statins

Statins such as simvastatin, rosuvastatin, or atorvastatin are administered and recommended to virtually all patients to maintain an LDL cholesterol of less than 80 mg/dl (2.0 mmol/L). This step is necessary to prevent graft occlusion and prevents fatal or nonfatal myocardial infarction.

4. Calcium Antagonists

Drugs such as oral nitrates and calcium antagonists are not usually required except if angina recurs. Many patients are continued for years on these unproven and costly drugs.

Calcium antagonists are strongly recommended to prevent spasm of the artery if a radial graft is used. Hypertension is best managed with an ACE inhibitor, a beta-blocker, or a small dose of a diuretic rather than with a calcium antagonist.

C. Other Advice

Patients are strongly advised to stop smoking. They are encouraged to engage in an exercise program and maintain a low-cholesterol, low-saturated-fat diet. Blood pressure

should be checked every four months to be sure that it is not elevated because this may aggravate the problems of blockage in the graft.

Patients must be strongly advised that atherosclerotic disease is not cured by surgery. Coronary thrombosis can still occur. The vein graft can develop atherosclerosis over a period of 10–15 years as veins are not usually subjected to the blood pressure found in arteries. The average pressure found within veins is normally about 5–7 mmHg as compared to the normal pressure in arteries of about 110–150 mmHg. One study showed that at 10 years post surgery more than half of the grafts were narrowed or blocked, particularly in individuals who continued to smoke cigarettes or in those with hypertension and increased cholesterol levels. Clinical trials done from 1994 to 1995 have established that the use of statins to maintain LDL cholesterol at less than 80 mg/dl (2.0 mmol/L) prevents the progression of atheroma and reduces the need for angioplasty and repeat bypass surgery (see the chapter Cholesterol).

IX. CORONARY BYPASS SURGERY VERSUS PCI

Coronary artery bypass surgery is not in competition with PCI (coronary angioplasty with intracoronary stent). The two methods of treatment are complimentary. Many of the surgical studies listed were done without the use of internal mammary artery grafts. Also, the PCI studies consist mainly of coronary angioplasty with only some patients receiving stents. Most important, the new drug-eluting stents are superior to older stents and produce up to 90% reduction in stent stenosis (a restenosis rate of <5%). Randomized clinical trials that compare internal mammary artery grafts and the drug-eluting stents are necessary to evaluate these two strategies.

Despite the usefulness and popularity of bypass surgery, alternatives are being sought that may avoid the morbidity of a sternotomy, aortic cross-clamping, and the neurocognitive sequelae of cardiopulmonary bypass. This is particularly important in individuals over age 70.

A. Drug-Eluting Stents

These stents will undoubtedly be the preferred treatment of choice for the following:

- Single-vessel disease
- Double-vessel disease with a near normal or normal EF

- Some patients with triple-vessel disease, normal left ventricular function, and an EF equal to or greater than 50%
- Post bypass surgery patients with obstructive grafts may be suitable for PCI; when feasible this avoids the high mortality of reoperation

B. Coronary Artery Bypass Surgery

Regardless of how beneficial stents become in the future, surgery will remain necessary for some of the following:

- Left main coronary artery disease
- Triple-vessel disease including the proximal LAD
- Double-vessel disease in the presence of left ventricular dysfunction and an EF of less than 40%
- Chronic total coronary occlusion, calcified lesions, ostial lesions, and lesions at sites not amenable to angioplasty and stent placement
- Selected diabetics except in those with single-vessel disease or with contraindication to surgery

In the Bypass Angioplasty Revascularization Investigation (BARI) trial (see Table 2), survival at 5 years with bypass surgery was superior compared with angioplasty (80.6% versus 65.5%; $P=0.003$). Improvement in survival was related to the presence of internal mammary artery graft. After angioplasty but not with bypass surgery coronary angiographic evidence of a myocardium in jeopardy increased in diabetics from one to five years. The Arterial Revascularization Therapy Study (ARTS) trial (see Table 2), in which stents had a role in diabetic patients treated with PCI, showed diabetics with lower events of free survival at one year (63.4%) than nondiabetics after PCI (76.2%) or diabetics who were treated with bypass surgery (84.4%).

Trials given in Table 2 were carried out in patients with preserved left ventricular systolic function, double-vessel disease and comorbidities. They may not reflect actual mortality differences between bypass surgery and PCI.

C. Clinical Study: The SOS Investigators

Study question: What is the effectiveness of stent-assisted PCI compared to bypass surgery in the management of patients with multivessel disease?

Methods: Patients with symptomatic multivessel disease were randomized to bypass surgery ($n=500$) or stent-assisted PCI ($n=488$). Analysis of the primary (repeat vascularization) and secondary end points (death, Q-wave myocardial infarction, or all-cause mortality) was by intention to treat.

Results: At the median follow up of two years patients undergoing PCI were more likely to require additional revascularization compared with the surgery group (21% vs. 6%; $p=0.0001$). The combined end point of death and Q-wave infarction was similar. Most important, fewer patients in the bypass group died compared with the PCI group (2% vs. 5%; $p=0.01$).

The ERAC1 II trial was a small study of only 450 patients followed for 18.5 months; a high percentage of unstable patients were enrolled in this study compared to others and this may relate to poorer surgical outcomes.

Hoffman et al. performed a meta-analysis of 13 recent randomized trials on 7964 patients comparing PCI and bypass surgery. Bypass surgery was associated with a lower five-year mortality, less angina, and fewer revascularization procedures. For patients with multivessel disease bypass surgery provided a survival advantage at 5–8 years. The addition of stents reduced the need for repeat revascularization by about half.

BIBLIOGRAPHY

- Abizaid, A., Costa, M. A., Centemero, M. et al. Clinical and economic impact of diabetes mellitus on percutaneous and surgical treatment of multivessel coronary disease patients: Insights from the arterial revascularization therapy study (ARTS) trial. *Circulation*, 104: 533–3821 2001.
- Acar, C., Ramsheyi, A., Pagny, J. Y. et al. The radial artery for coronary artery bypass grafting: Clinical and angiographic result at five years. *J. Thorac. Cardiovasc. Surg.*, 116:981, 1998.
- Anonymous. Coronary angioplasty versus coronary artery bypass surgery. the randomized intervention treatment of angina (RITA) Trial. *Lancet*, 341:573, 1993.
- BARI Investigators. Influence of diabetes on 5-year mortality and morbidity in a randomized trial comparing CABG and PTCA in patients with multivessel disease. The Bypass Angioplasty Revascularization Investigation (BARI) trial. *Circulation*, 96(6):1761–69, 1997.
- Barner, H. B., Standeven, J. W., and Reese, J. 12 year experience with internal mammary artery for coronary artery bypass. *J. Thorac. Cardiovasc. Surg.*, 90:668, 1985.
- Bell, M. R., Gersh, B. J., Schaff, H. V. et al. Effect of completeness of revascularization on long-term outcome of patients with three vessel disease undergoing coronary artery bypass surgery. A report from the Coronary Artery Study (CASS) Registry. *Circulation*, 86:446, 1992.
- CAPRICORN Investigators: Effect of carvedilol on outcome after myocardial infarction in patients with left ventricular dysfunction: The CAPRICORN randomized trial. *Lancet*, 357:1385–90, 2001.
- COPERNICUS: Carvedilol prospective randomized cumulative survival study group one effect of carvedilol on survival in severe chronic atrial fibrillation. *N. Engl. J. Med.*, 344:1651–58, 2001.
- Demaria, R. G., Carrier, M., Fortier, S. et al. Reduced mortality and strokes with off-pump coronary artery bypass grafting surgery in octogenarians. *Circulation*, 106:1–10, 2002.
- Elefteriades, J. A., Tolis, G., Jr., Levi, E. et al. Coronary artery bypass grafting in severe left ventricular dysfunction. Excellent survival and functional status. *J. Am. Coll. Cardiol.*, 22:1411, 1993.
- Favorolo, R. G. Saphenous vein autograft replacement of severe segmental coronary artery occlusion. *Ann. Thorac. Surg.*, 5:334, 1968.
- Garrett, H. E., Dennis, E. W., and DeBakey, M. E. Aortocoronary bypass with saphenous vein graft. Seven year follow-up. *JAMA*, 223:792, 1973.
- Green, G. E., Spencer, F. C., Tice, D. A. et al. Arterial and venous microsurgical bypass grafts for coronary artery disease. *J. Thorac. Cardiovasc. Surg.*, 60:491, 1970.
- Hoffman, S. N., TenBrook, J. A., Wolf, M. P. et al. A meta-analysis of randomized controlled trials comparing coronary artery bypass grafts with percutaneous transluminal coronary angioplasty: One- to eight-year outcomes. *J. Am. Coll. Cardiol.*, 41:1293–1314, 2003.
- Ivanov, J., Weisel, R. D., David, T. E. et al. 15-year trends in risk severity and operative mortality in elderly patients undergoing coronary artery bypass graft surgery. *Circulation*, 97:673, 1998.
- Khot, U. N., Friedman, D. T., and Pettersson, G., Radial artery bypass grafts have an increased occurrence of angiographically severe stenosis and occlusion compared with left internal mammary arteries and saphenous vein grafts. *Circulation*, 109:2086–2209, 2004.
- Kip, K. E., Alderman, E. L., Bourassa, M. G. et al. Differential influence of diabetes mellitus on increased jeopardized myocardium after initial angioplasty or bypass surgery: Bypass angioplasty revascularization investigation. *Circulation*, 105(16):1914–20, 2002.
- Kolesov, V. I. Mammary artery–coronary artery anastomosis as method of treatment for angina pectoris. *J. Thorac. Cardiovasc. Surg.*, 54: 535, 1967.
- Marcel, J. B., van den Brand, B. J. W. M., Rensing, M.-A., Morel, M. et al. The effect of completeness of revascularization on event free survival at one year in the ARTS trial. *J. Am. Coll. Cardiol.*, 59:559–64, 2002.
- Morrison, D. A., Sethi, G., Sacks, J. et al. Percutaneous coronary intervention versus repeat bypass surgery for patients with medically refractory myocardial ischemia; AWESOME randomized trial and Registry experience with post CABG patients. *J. Am. Coll. Cardiol.*, 40:1951–4, 2002.
- Peduzzi, P., Kamina, A., and Detre, K. 12- year follow up in the VA Cooperative study of coronary artery bypass surgery for stable angina. *Am. J. Coll. Cardiol.*, 81:1393, 1998.
- Schaff, H. V., Gersh, B. J., Fisher, L. D. et al. Detrimental effect of perioperative myocardial infarction and late survival after coronary artery bypass. Report from the Coronary Artery Surgery Study (CASS). *J. Thorac. Cardiovasc. Surg.*, 88:972, 1984.
- SOS Investigators. Coronary artery bypass versus percutaneous coronary intervention with stent implantation in patients with multivessel coronary disease (the stent or surgery trial), a randomized controlled trial. *Lancet*, 360:965–70, 2002.

C-Reactive Protein and the Heart

- I. A Marker of Risk
- II. Clinical Studies
- III. Perspective and Research Implications

GLOSSARY

allograft a graft between animals of the same species, but of different genotype.

angina chest pain caused by temporary lack of blood to an area of heart muscle cells, usually caused by severe obstruction of the artery supplying blood to the segment of cells.

atheroma the same as atherosclerosis, raised plaques filled with cholesterol, calcium, and other substances on the inner walls of arteries that obstruct the lumen and the flow of blood; the plaque of atheroma hardens the artery, hence the term atherosclerosis (sclerosis = hardening).

Atherothrombosis thrombosis complicating a ruptured or fissured plaque of atheroma

dyslipidemia the same as hyperlipidemia, elevated blood cholesterol, LDL cholesterol, triglycerides, or low HDL cholesterol.

myocardial infarction death of an area of heart muscle due to blockage of a coronary artery by blood clot and atheroma; medical term for heart attack or coronary thrombosis.

unstable angina severe angina usually occurring at rest.

I. A MARKER OF RISK

C-reactive protein (CRP) is an acute phase reactant produced by the liver in response to inflammatory cytokines (IL-1, IL-6) and tumor necrosis factor- α (TNF- α). C-reactive protein has been identified as a marker of risk for coronary events independent of other factors.

Although CRP has been found in atheromatous plaques and is suspected to enhance rupture of the plaque by both activating complement and impairing endothelial cell function, the exact source of elevated CRP levels among patients with acute coronary syndromes remains unclear.

The suspicion is difficult to prove, and it is not well established if CRP is a marker of risk, a risk factor, or both.

In some studies CRP has been found to have prognostic value among patients without evidence of myocardial necrosis. In patients with acute coronary syndromes and negative troponin-T, elevated CRP appears to be predictive of future adverse events. In addition it has been observed that CRP is a strong independent predictor of short- and long-term mortality among patients treated with early revascularization.

Many workers in the field agree high levels of CRP are associated with an increased risk of cardiovascular diseases, but the predictive power of this association is markedly diminished when adjusted for the risk factors. The clinical significance of the added value of CRP over conventional markers of coronary artery disease remains debatable.

Some studies have shown elevated CRP levels in more than two-thirds of patients diagnosed with unstable angina, and these levels declined somewhat within 6 months. Such high levels occur in association with unstable coronary plaque activation and increase in subsequent coronary events including progression of unstable angina for myocardial infarction. These findings, however, are much less common in patients who present with acute myocardial infarction without preceding unstable angina.

Current techniques are not sufficiently reliable and coronary angiography has not been very useful in identifying inflamed atheromatous plaques. In addition it has been well established that serious cardiac events that included acute coronary syndromes (unstable angina, an acute myocardial infarction) often occur in coronary arteries in which the obstruction by plaque is less than 60% reflecting mild-to-moderate degrees of coronary artery stenosis. There is no doubt, however, that in both chronic and acute coronary syndromes a high CRP is often present and is associated with adverse short- and long-term prognosis. These findings suggest some form of inflammatory process that increases the size of the plaque and may predispose the plaque to rupture (see Fig. 1). In studies of

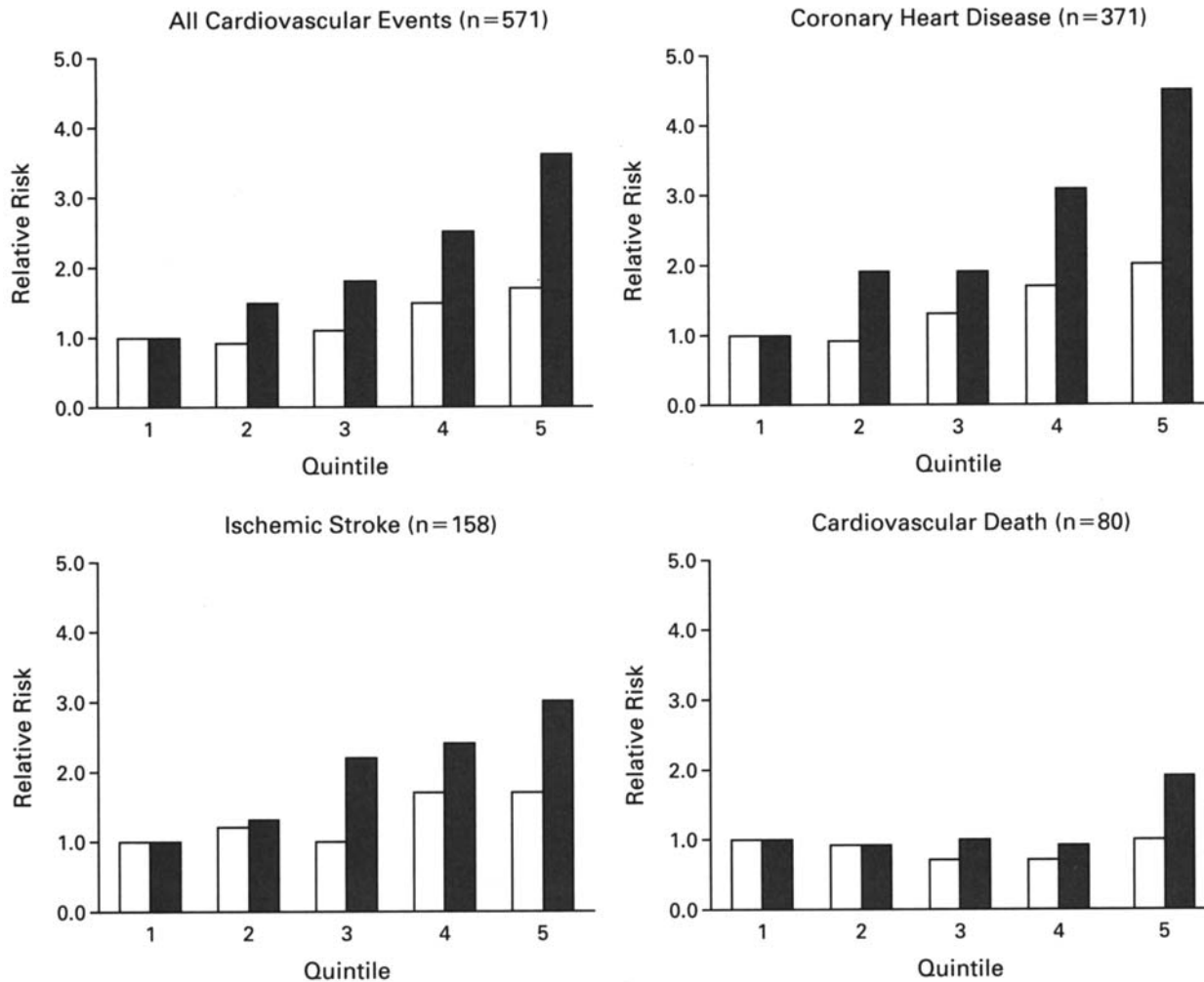

FIGURE 1 Age-adjusted relative risk of future cardiovascular events, according to base-line C-reactive protein levels (solid bars) and LDL cholesterol levels (open bars). (From *N. Engl. J. Med.*, 347(20), 1561, 2002.)

patients undergoing coronary angiography, an intracardiac inflammatory response has been observed in patients with unstable angina that appears to be a result of low-grade myocardial necrosis. The ruptured plaque does not appear to contribute to the acute phase response.

It must be emphasized, however, that an inflammatory response may be mounted by the body in the absence of infection by bacteria or other microorganisms. A nonspecific inflammatory response may be caused by several natural mechanisms mounted by the body as a protective measure. The mechanisms (pathogenesis) that underlie the formation and progression of atheromatous lesions and the rupture that finally causes obstruction of blood flow require considerable further research. The excellent research and investigative work on coronary artery disease carried out in many centers worldwide over the past 30 years have not resulted in a major breakthrough.

II. CLINICAL STUDIES

A. Ridker et al.

Study question: CRP and LDL cholesterol levels are both elevated in individuals at risk for cardiovascular events. This study sought population-based data that directly compared these two biological markers because such data are not available.

Methods: LDL cholesterol and CRP were measured at baseline in 27,939 healthy American women. The occurrence of myocardial infarction, ischemic stroke, or death from cardiovascular causes at follow up of 8 years was analyzed.

Results: Overall, 77% of all events occurred among women with LDL cholesterol levels below 160 mg/dl (4.14 mmol/L) and 46% occurred among those with LDL

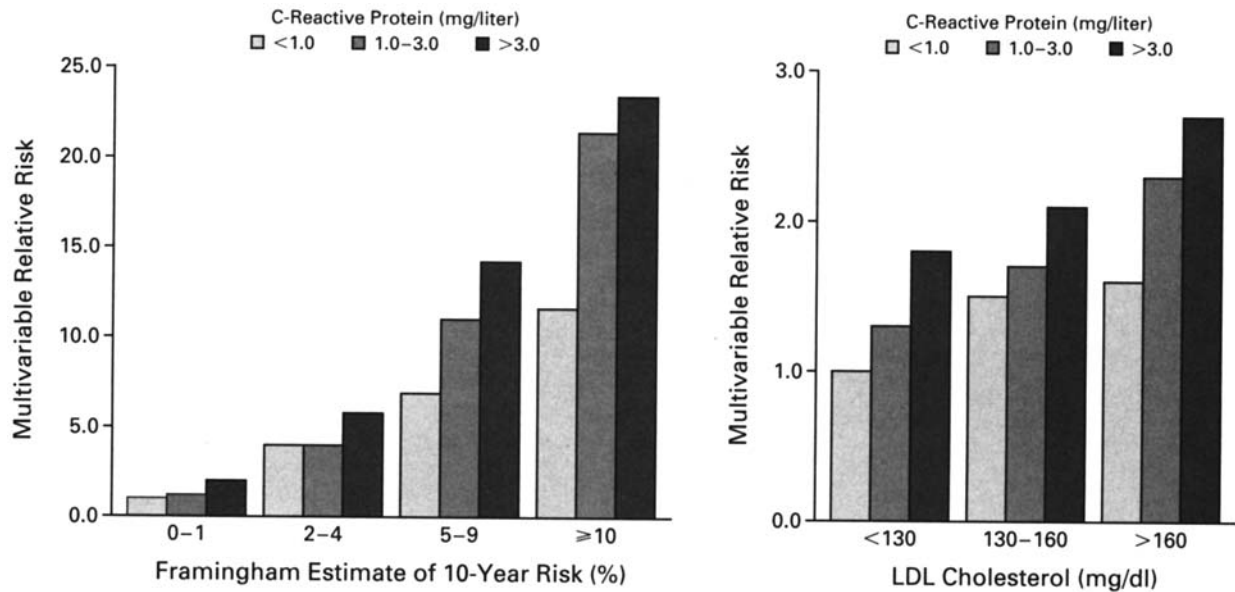

FIGURE 2 Multivariable-adjusted relative risks of cardiovascular disease according to levels of C-reactive protein and the estimated 10-year risk based on the Framingham Risk Score as currently defined by the National Cholesterol Education Program and according to levels of C-reactive protein and categories of LDL cholesterol. (From *N. Engl. J. Med.*, 347(20), 1564, 2002.)

cholesterol levels below 150 mg/dl (3.36 mmol/L). The level of CRP showed an apparent superiority over LDL cholesterol in terms of the prediction of risk of the composite end point: coronary heart disease, stroke, and death from cardiovascular causes (see Fig. 1). Comparison with the Framingham risk score is given in Fig. 2.

Conclusion: The authors of this study concluded: the data suggest that CRP is a stronger predictor of cardiovascular events than LDL cholesterol levels, and that it adds prognostic information over and above that obtained with LDL cholesterol and other risk score assessments.

B. Study by Labarrere et al.

This study showed that heart transplant recipients with high concentrations of CRP have more severe and more rapid progression of coronary artery disease in the transplant. In addition, this finding was associated with a high expression of endothelial intracellular adhesion molecule-I (ICAM-I) and high concentrations of ICAM-I in serum. Eisenberg et al. found that the rise in CRP levels in nine consecutive cardiac transplant patients significantly predicted graft failure. At 10-year follow up there was a significant reduction of allograft survival in patients with high CRP. Immune mechanisms have been postulated because only the vessels of the allograft were involved with accelerated atherosclerosis sparing the host's native arteries.

C. Study by Danesh et al.

This large, well-conducted study concluded that elevated levels of C-reactive protein are associated with only a moderate increase in the risk of coronary heart disease.

III. PERSPECTIVE AND RESEARCH IMPLICATIONS

Investigative methods for detecting vulnerable atherosclerotic plaques include intravascular ultrasonography, magnetic resonance imaging plaque thermography, and circulating markers such as CRP and cytokines may have a role in the future. Evidence is insufficient to warrant widespread screening with CRP. The measurement would be of practical value in patients with coronary artery disease and cardiovascular disease, with optimal levels of LDL cholesterol greater than 95 mg/dl (2.5 mmol/L; to convert values for LDL cholesterol to mmol per liter multiply by 0.02586).

There is little doubt that the link between inflammation and clinical coronary artery disease is strong, but important gaps in our knowledge remain. The atheromatous plaque itself may initiate an inflammatory response. Although infection appears to accelerate the clinical course of atheroma, the contribution of infection in areas of the

body outside the plaque to nonspecific inflammatory activity within the arterial wall remains obscure. Randomized clinical trials using antibiotics in patients with acute coronary syndrome have not been beneficial. Further large-scale clinical trials are unnecessary. Even if the inflammation hypothesis is correct, the cost effectiveness of altering management on the basis of the results of screening for CRP needs to be determined.

Patients with heart disease or cardiovascular disease with LDL cholesterol levels greater than 2.5 mmol/L are recommended to receive a statin to maintain a goal of less than 2.5 mmol/L. The treatment with statins has been shown to reduce CRP levels.

Patients at high risk: acute coronary syndrome, should achieve LDL goal of less 80 mg/dl (2 mmol/l) and CRP levels lowered to normal regardless of LDL levels. Ridker et al. indicate that CRP monitoring should be used in patients with acute coronary syndrome to assess risk; patients who have low CRP levels after statin therapy appear to have better clinical outcomes than those with higher CRP levels regardless of the level of LDL achieved.

BIBLIOGRAPHY

- Blake, G., and Ridker, P. M. C-reactive protein and other inflammatory risk markers in acute coronary syndromes. *J. Am. Coll. Cardiol.*, 41:37S–42S, 2003.
- Buffon, A., Biasucci, L. M., Luzzo, G. et al. Widespread coronary inflammation in unstable angina. *N. Engl. J. Med.*, 347:5–12, 2002.
- Cusak, M. R., Marber, M. S., Lambiase, P. D. et al. Systemic inflammation in unstable angina is the result of myocardial necrosis. *J. Am. Coll. Cardiol.*, 39:1917–23, 2002.
- Danesh, J., Wheeler, J. G., Hirschfield, G. M. et al. C-reactive protein and other circulating markers of inflammation in the prediction of coronary heart disease. *N. Engl. J. Med.*, 350:1387–1397, 2004.
- Eisenberg, M. S., Chen, H. J., Warshofsky, M. K. et al. Elevated levels of plasma C-reactive protein are associated with decreased graft survival in cardiac transplant recipients. *Circulation*, 102:2100–2104, 2000.
- Feldman, M., Jialal, I., Devaraj, S. et al. Effects of low-dose aspirin on serum C-reactive protein and thromboxane B2 concentrations: A placebo-controlled study using a highly sensitive C-reactive protein assay. *J. Am. Coll. Cardiol.*, 37:26–41, 2001.
- Labarrere, C. A., Lee, J. B., Nelson, D. R. et al. C-reactive protein, arterial endothelial activation, and development of transplant coronary artery disease: A prospective study. *Lancet*, 360:1462–1467, 2002.
- Mosca, L. C-reactive protein — to screen or not to screen? *N. Engl. J. Med.*, 347:1615–16, 2002.
- Nissen, S. E., Tuzcu, E. M., Schoenhagen, P. et al. For the reversal of atherosclerosis with aggressive lipid lowering (REVERSAL) investigators statin therapy, LDL cholesterol, C-reactive protein, and coronary artery disease. *N. Engl. J. Med.*, 352:29–38, 2005.
- Ridker, P. M., Rifal, N., Rose, L. et al. Comparison of C-reactive protein and low-density lipoprotein cholesterol levels in the prediction of first cardiovascular events. *N. Engl. J. Med.*, 347:1557–65, 2002.
- Ridker, P. M., Cannon, C. P., Morrow, D. et al. For the Pravastatin or Atorvastatin Evaluation and Infection Therapy–Thrombolysis in Myocardial Infarction 22 (PROVE IT–TIMI 22) Investigator: C-reactive protein levels and outcomes after statin therapy. *N. Eng. J. Med.*, 352:20–28, 2005.
- Rossi, E. C-reactive protein and progress of atherosclerosis. *Lancet*, 360:1436, 2002.
- Tall, A. R. C-reactive protein reassessed. *N. Engl. J. Med.*, 350: 1450–1452, 2004.

Cytochrome P-450

- I. Definition and Nomenclature
- II. Functions
- III. P-450s Regulation
- IV. P-450s and Cardiovascular Drug Interactions

GLOSSARY

- antiarrhythmic agents** cardioactive drugs used to prevent and treat arrhythmias.
- myopathy** disease of muscle.
- rhabdomyolysis** disintegration of striated muscle fibers with excretion of myoglobin in the urine.
- xenobiotic** compound that is foreign to the body, such as a drug or an environmental pollutant.

THE CYTOCHROME P-450 (CYP450) METABOLIC pathway is involved in the metabolism of many cardiovascular medications. Many significant drug interactions often involve this pathway.

I. DEFINITION AND NOMENCLATURE

Cytochrome P-450 refers to a colored substance in the cell that absorbs light at around 450 nm within the visible spectrum. The word cyto means cell and chrome means color. The P in P-450 refers to pigment and the 450 refers to its wavelength.

Cytochrome is a cellular heme-containing protein. Its principal function is electron transport. Hemoglobin transports oxygen whereas cytochrome P-450 is a monooxygenase using one atom from oxygen and two electrons to oxidize chemical substrates.

In the early 1960s P-450 was thought to be one enzyme. Gonzales et al. isolated the first cDNA encoding a complete cytochrome P-450 protein. Since then dozens of different enzymes have been isolated. The P-450 cytochromes are ubiquitous enzymes found in microorganisms

and throughout the plant and animal kingdoms. The mustard plant contains 249 active CYP genes and the rice plant has 324. The human cytochrome P-450 has 57 genes.

Cytochrome P-450 proteins are arranged into families and subfamilies on the basis of percentage of amino acid sequence identity. Enzymes that share more than 40% identity are assigned to a particular family designated by an Arabic numeral, whereas those sharing more than 55% identity make up a subfamily designated by a letter.

II. FUNCTIONS

The human cytochrome P-450 superfamily is comprised of 57 genes. Cytochrome P-450s use electrons from nicotinamide adenine dinucleotide (NADH) and oxygen to oxidize their substrates. These genes code for enzymes that have a role in many metabolic processes including:

- Metabolism of drugs and foreign chemicals including plant metabolites and environmental contaminants
- Metabolism of arachidonic acid and eicosanoids
- Cholesterol metabolism and bile acid biosynthesis
- Steroid synthesis and metabolism
- Vitamin D3 synthesis and metabolism
- Retinoic acid hydroxylation
- Saturated and unsaturated fatty acids

The cytochrome P-450 acts on many endogenous substrates introducing oxidative, peroxidative, and reductive changes into small molecules. Cytochrome P-450s metabolize various drugs and natural plant products; environmental chemicals and pollutants are successfully detoxified. These important enzymes are the primary interface between humans and the chemical environment. The actions of these enzymes may produce toxic metabolites, however, that may increase risks of cancer, birth defects, and other toxic effects.

TABLE I

List of Human P-450s, Tissues in which they are Expressed, and Some of their Substrates

Gene ^a	Tissue ^b	Substrates ^c		
CYP1A1	Liver	Benzo(a)pyrene (C)		
	Lung	7,12-Dimethylbenz(a)anthracene (C)		
	Placenta			
	Other			
CYP1A2	Liver	Acetaminophen (D)		
		2-Acetylaminofluorene (C)		
		Aflatoxin B ₁ (C)		
		Heterocyclic arylamines (C)		
CYP1B1	Adrenal	Similar to CYP1A1		
	Ovaries			
CYP2A6	Liver (P)	Coumarin		
	Nasal epithelium	<i>N</i> -Nitrosodiethylamine (C)		
	Other			
CYP2B6	Liver (P)	7-Ethoxy-4-trifluoromethylcoumarin Aflatoxin B ₁ (C)		
CYP2B7	Lung			
CYP2C8	Liver	Tolbutamide (D) <i>R</i> -Mephenytoin (D)		
CYP2C9	Liver	Tolbutamide (D)		
		<i>R</i> -Mephenytoin (D)		
		Warfarin (D)		
		<i>S</i> -Mephenytoin		
CYP2C19	Liver			
CYP2D6	Liver (P)	Bufuralol (D)		
	Kidney	Debrisoquine (D)		
		Dextromethorphan (D)		
		Nortriptyline (D)		
CYP2E1	Liver	Propranolol (D)		
		Acetoacetate (E)		
	Other	Acetol (E)		
		Acetaminophen (D)		
		Ethanol (D)		
		Halothane (D)		
		<i>N</i> -Nitrosodiethylamine (C)		
		CYP2F1	Lung	7-Ethoxycoumarin
			Liver	Testosterone (E)
		CYP3A4	Other	Testosterone (E)
Aflatoxin B ₁ (C)				
Cortisol (E)				
Kidney	Cyclosporine (D)			
Other	Erythromycin (D)			
	Midazolam (D)			
	Nifedipine (D)			
	Warfarin (D)			
	Testosterone (E)			

(Continued)

TABLE I

Continued

Gene ^a	Tissue ^b	Substrates ^c
CYP3A5	Liver (P)	Similar to CYP3A4
	Other	
CYP3A7	Liver (fetal)	Dehydroepiandrosterone-3-sulfate (E)
CYP4A9	Liver	Lauric acid
	Other	Arachidonic acid (E) Other fatty acids
CYP4A11	Liver	Similar to CYP4A9
	Other	
CYP4B1	Lung	
	Other	
CYP7A1	Liver	Cholesterol (E)
CYP11A1	Adrenal gland	Cholesterol (E)
	Ovary	
	Testis	
CYP11B1	Adrenal gland	17 α -Hydroxyprogesterone (E)
	Ovary	
	Testis	
CYP17A1	Adrenal	Dehydroepiandrosterone (E)
	Ovary	
	Testis	
CYP19A1	Ovary	17 α -Hydroxyprogesterone (E)
	Placenta	
	Androstenedione (E)	
CYP21A2	Adrenal gland	Progesterone (E)
	Ovary	
CYP26A1 ^d	Ovary	17 α -Hydroxyprogesterone (E)
	Testis	
	Liver	Cholesterol (E)

^aThe amino acid sequences of all P-450s listed have been determined using human cDNA libraries, except for CYP26A1, which encodes the cholesterol 26-hydroxylase. Because this enzyme is a member of a cascade of enzymes involved in bile acid formation, it is presumed to exist in humans.

^bThe tissues listed are known to express P-450s, however, not every human tissue has been carefully examined. On the basis of studies in rodents, some P-450s are believed to be expressed in other tissues. Some genes are polymorphically expressed (P).

^cThe substrates listed fall into the classes of carcinogens (C), drugs (D), and endogenous compounds (E). The unmarked substrates are chemicals that happen to be substrates but are not drugs or carcinogens. The carcinogenicity of these compounds in rodents varies considerably from the potent aflatoxin B₁ to the weak heterocyclic arylamines. In most cases, the carcinogenic potency in humans is unknown. This list is not inclusive. Several of these P-450s are known or presumed to metabolize many other compounds. It should also be noted that a single substrate can be metabolized by multiple P-450 forms (e.g., aflatoxin B₁, 7-ethoxycoumarin).

^dPresent in rodents and believed to be present in humans.

(From Gonzalez, F.J. (1997). Cytochrome P-450. *Encyclopedia of Human Biology*, 2nd ed., San Diego: Academic Press, p. 124. With permission.)

Several P-450s are involved in the metabolism of foreign compounds (xenobiotics) such as drugs, plant-derived or fungal-derived secondary metabolites consumed with food, and thousands of environmental pollutants that include arylamines, halogenated hydrocarbons, herbicides, industrial complex mixtures, ingredients of combustion, pesticides, and polycyclic aromatic hydrocarbons.

Deficiencies in the xenobiotic-metabolizing P-450s are associated with clinical drug oxidation polymorphisms which result in toxic reactions to several prescription drugs. Table 1 gives a list of human P-450s, the tissues in which they are expressed, and some of their substrates. Figure 1 gives the substrates for CYP2D6 which include the commonly used beta-adrenergic blocking and antiarrhythmic agents.

III. P-450s REGULATION

Human P-450s that metabolize foreign chemicals are virtually all in the CYP1, CYP2, CYP3, and CYP4 families. P-450s are regulated by a number of xenobiotics and the cellular content of a P-450 is elevated by the same compound that it metabolizes. This induction of P-450s by various compounds is known to advance via a receptor-mediated mechanism.

IV. P-450s AND CARDIOVASCULAR DRUG INTERACTIONS

The induction of P-450s has implications for significant cardiovascular drug interactions including statins and beta-adrenergic blocking agents.

A. Statins

The HMG-CoA reductase inhibitors, statins, are potent cholesterol-lowering agents used worldwide. Myopathy, rhabdomyolysis, and deaths have been reported in patients receiving therapy with statins. This adverse effect is caused by elevated blood levels of these agents. Patients at high risk are those concurrently taking other medications known to be metabolized by the P-450 metabolic pathway, thereby inhibiting clearance of the statin. A main route of atorvastatin, cerivastatin, lovastatin, and simvastatin metabolism is via cytochrome P-450 3A4. Cases of lovastatin-induced rhabdomyolysis associated with medications such as azithromycin, erythromycin, and clarithromycin have been reported. Fluvastatin inhibits CYP2C9, and interactions between fluvastatin and other CYP2C9

substrates such as oral anticoagulants including warfarin, oral hypoglycemic agents, phenytoin, and nonsteroidal anti-inflammatory drugs (NSAIDs) may occur.

Cerivastatin (Baycol) is metabolized by both 3A4 and 2C8; the drug was withdrawn from the market in 2001 because of the occurrence of rhabdomyolysis, kidney failure, and 52 deaths worldwide. Some of these deaths occurred because of high-dose cerivastatin therapy, and several were caused by interactions with gemfibrozil, a fibrate. A statin combined with a fibrate is not an approved combination. The fibrates are partly metabolized by the 3A4 pathway. When cerivastatin was given together with other agents such as cyclosporine, erythromycin, and itraconazole, there was a potential for drug interactions because its concentration increased by 40–300%.

Caution: The statins, particularly lipophilic agents that use the P-450 pathway, should not be combined with the following drugs that also use the pathway:

- Fibrates
- Antibiotics such as azithromycin, clarithromycin, erythromycin, and rifampicin
- Antifungal agents such as itraconazole
- Cyclosporine
- Niacin (the combination with a statin is being tested in a clinical trial)

Other agents and substances known to be metabolized by the P-450 pathway and are potential interactants include fluoxetine and other antidepressant agents, nefazodone, grapefruit juice, amlodipine and other dihydropyridine calcium antagonists, and Viagra. Fluvastatin can inhibit 2C9-mediated oxidation of diclofenac, an NSAID, resulting in increased peak plasma concentrations of diclofenac. A Fluvastatin and warfarin interaction has been reported. Mibefradil (Posicor), a calcium antagonist, was removed from the market recently because it interacted significantly with other medications that are metabolized by P-450 3A4. The interaction caused serious arrhythmias including torsades de pointes. Prior to the recall of this product, the pharmaceutical firm cautioned against the combination with statins because of reported cases of rhabdomyolysis in patients receiving simvastatin and Posicor.

Recent experience with troglitazone is relevant. Despite increasing reports of acute liver failure and four successive warning letters from the Food and Drug Administration, by the time of its withdrawal from the market the drug had been linked to 43 cases of liver failure.

Pravastatin and rosuvastatin are hydrophilic statins that are eliminated by the kidney. They are not metabolized by the P-450 pathway which may render them relatively safer components of the statin armamentarium when

β -ADRENERGIC BLOCKING AGENTS**TRICYCLIC ANTIDEPRESSANTS****CARDIOVASCULAR DRUGS****MISCELLANEOUS**

FIGURE 1 Substrates for CYP2D6. The hydroxylation positions of each substrate are indicated by arrows. The conversion of the analgesic codeine to its active derivative morphine is shown at the bottom of the figure. (From Gonzalez, F.J. (1997). Cytochrome P-450. *Encyclopedia of Human Biology*, 2nd ed., San Diego: Academic Press, p. 124. With permission.)

agents that are metabolized by P-450 are administered simultaneously.

converts the inactive analgesic codeine to its active derivative morphine.

B. Beta-Adrenergic Blocking Agents

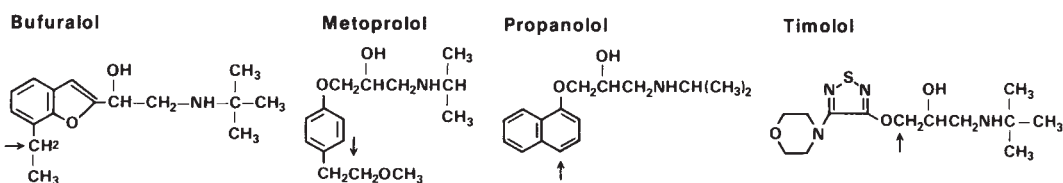
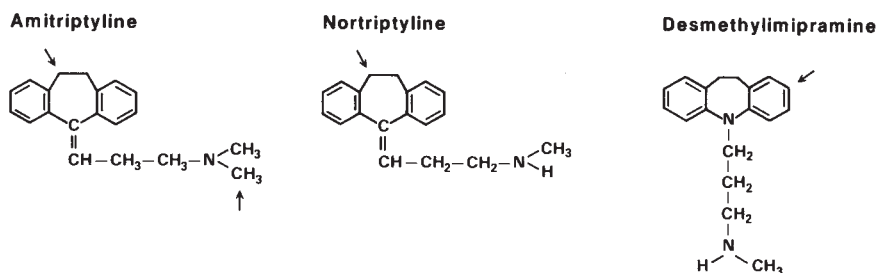
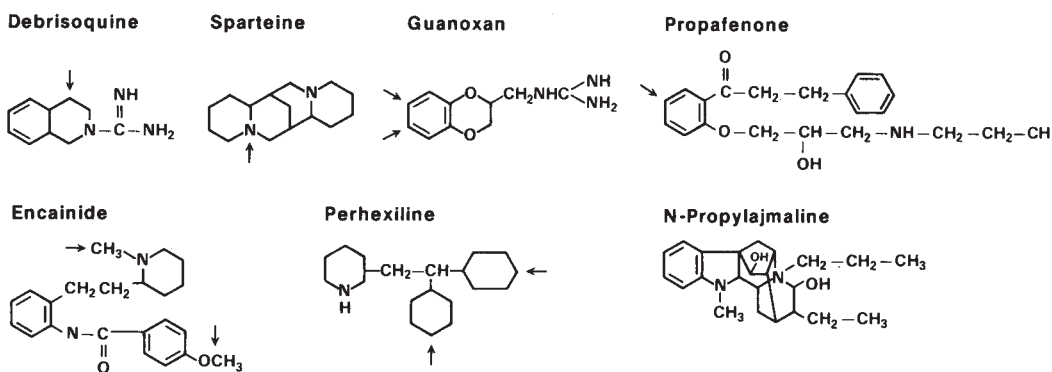
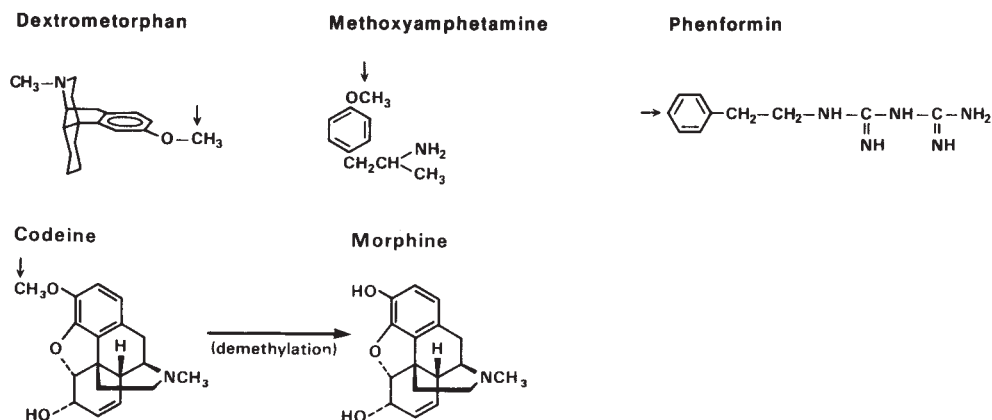
Beta-blockers are cardioactive agents commonly used in the management of angina, heart attacks, hypertension, arrhythmias, and heart failure. These agents have been used worldwide since 1969. Interactions are, however, few. A single P-450 can oxidize a large number of drugs (see Fig. 1) and CYP2D6 can metabolize compounds with a wide range of structures such as beta-blockers, tricyclic antidepressants, antiarrhythmics, and dextromethorphan, a component of cough suppressants. This enzyme also

BIBLIOGRAPHY

- Farmer, J. A. Learning from the cerivastatin experience. *Lancet*, 358:1383–84, 2001.
- Fleming, I. Cytochrome P-450 under pressure: More evidence for a link between 20-hydroxyecosatetraenoic acid and hypertension. *Circulation*, 111:5–7, 2005.
- Gonzalez, F. J. Cytochrome P450. *Encyclopedia of Human Biologym*, second edition. Academic Press, San Diego, 1997, p. 115.
- Nebert, D. W., and Russell, D. W. Clinical importance of the cytochromes P450. *Lancet*, 360:1155–62, 2002.

Deep Vein Thrombosis

- I. Incidence and Location
- II. Pathogenesis of Deep Vein Thrombosis
- III. Diagnostic Features
- IV. Management

GLOSSARY

- distal** further away from the heart and near to the feet or fingers.
- edema** accumulation of fluid.
- embolus, embolism** a blood clot that forms in an artery, a vein, or the heart that breaks off and is carried by the circulating blood, finally lodging and blocking the artery that supplies an organ with blood; for example, pulmonary embolism is an embolus blocking the artery in the lung.
- fibrin** an insoluble protein that is essential to clotting of blood, formed from fibrinogen by action of thrombin.
- hypercoagulability** increased clotting of blood.
- phlebitis** inflammation of the wall of a vein.
- prophylaxis** prevention of disease; preventive treatment.
- proximal** near to a center point of the body such as the heart.
- thrombus (thrombi)** blood clot(s).

I. INCIDENCE AND LOCATION

A. Incidence

Deep vein thrombosis occurs in the veins of the legs, thigh, and pelvis. It can lead to a life-threatening condition called pulmonary embolism and is a common problem worldwide. The incidence of venous thromboembolism in the United States is approximately 600,000 cases annually. Approximately 30% of patients undergoing major surgery develop deep vein thrombosis and some cases may go undetected. High-risk procedures such as implantation of knee or hip prosthesis or other orthopedic surgery on these joints have an incidence of deep vein thrombosis of approximately 50–60% with more dangerous proximal versus below-the-knee distal deep vein thrombosis.

B. Location

Thrombosis of veins that lie deep in the calf or thigh muscle are more dangerous than clots occurring in superficial veins just under the skin, because deep veins are much larger and communicate more directly with the lungs and the heart. A thrombus that is lodged in the femoral or iliac veins may break off and travel into the bloodstream, be carried to the right heart and pumped into the lungs. This traveling clot is called an embolus, thus the term pulmonary embolism. Because pulmonary embolism occurs in patients with thrombosis of the femoral and iliac veins, this condition is considered life-threatening. Thrombi in veins below the knee close to the ankle may not extend above the knee and this type of clot rarely embolizes. The incidence of postphlebitic syndrome, however, in these so-called benign clots is approximately 35%. Postphlebitic syndrome causes swelling of the legs and aching that may persist for years. It is important to make the diagnosis of thrombi above the knee. Although thrombi occurring in veins between the knee and the feet are not as dangerous as those above the knee, they do cause bothersome swelling and pain. Unfortunately the diagnosis of below-the-knee thrombosis is often missed by ultrasonography.

II. PATHOGENESIS OF DEEP VEIN THROMBOSIS

A. Immobilization

Thrombi form in veins of the lower limbs and pelvis because of certain factors that increase the tendency of free-flowing blood to clot. A sudden increase in the tendency of the blood to clot commonly occurs soon after surgical operations or fractures that immobilize the lower limbs. Sudden immobilization for more than 48 h causes the blood to flow very slowly through the limb that is immobilized. This slow-flowing (stasis) blood through veins in the extremities tends to form “sludge” and clots. This is

similar to very slow-flowing or stagnant water in a stream that forms moss on rocks. Immobilization, therefore, explains the high incidence of clots in veins after surgical operations that involve the lower limbs versus surgery of the chest and upper regions of the body where the lower limbs are free to move.

B. Coagulation Factors

Soon after surgery or the birth of a baby small particles in the blood called platelets become sticky and clump together. This together with other substances called coagulation factors in the blood orchestrate the clot; once a reaction is initiated there is a cascade of processes that lead to the formation of a firm, fibrin clot.

Damage to veins by traumatic injury and infections also predispose to clot formation.

C. Predisposing Factors

I. Surgery and Immobilization

Situations that are associated with or predispose a patient to deep vein thrombosis and thromboembolism include:

- Surgery, injury, or fractures of the lower extremities or pelvis including soft tissue injury
- Orthopedic surgery of the hip or the knee
- Prolonged anesthesia associated with surgery
- Bed rest and sudden immobilization for more than 48 h
- Heart failure which causes slow circulation through the venous system because the heart pumps inefficiently and these patients are partially immobilized
- Cancer of different types may cause changes in the coagulation factors and an increased tendency to clot
- Pregnancy and within 48 h of giving birth; platelets and other coagulation factors are activated perhaps as nature's way of preventing placental hemorrhage
- Use of oral contraceptives or estrogens
- Obesity
- Sitting for more than 8 h while on an airplane

A study by Scurr et al. concluded that asymptomatic deep vein thrombosis might occur in up to 10% of long-haul airline travelers. The investigators recruited 89 male and 142 female passengers over 50 years of age with no history of thrombotic problems. Passengers were randomly allocated to one group who wore below-the-knee elastic compression stockings while the other group did not. All passengers made journeys lasting longer than 8 h. Duplex ultrasonography was used to assess the deep veins

before and after travel. Twelve of 116 passengers developed asymptomatic deep vein thrombosis in the calf. Of these passengers, none wore elastic compression stockings. None of the passengers who wore class 1 compression stockings developed deep vein thrombosis. The authors concluded that wearing elastic compression stockings during normal air travel is associated with a reduction in asymptomatic deep vein thrombosis.

2. Inherited Diseases

Diseases that cause hypercoagulability states include:

- Factor V Leiden (a mutation in coagulation factor V that results in resistance to activated protein C or aPC)
- Antithrombin 3 deficiency
- Protein C deficiency
- Protein S deficiency
- Antiphospholipid antibody syndrome (see the chapter Antiphospholipid Antibody Syndrome)

III. DIAGNOSTIC FEATURES

A. Symptoms and Signs

Deep vein thrombosis occurring in the lower limbs is often difficult to diagnose from the history and physical examination. Some individuals present with pain and swelling of the calf muscle, others are asymptomatic. The obstruction to the vein causes chronic congestion of the muscle tissues which become edematous. The diagnosis may be confused with other conditions that cause aches and pains in the lower limbs such as a muscle tear, muscle cramps, a ruptured Baker's cyst, cellulitis, and postphlebotic syndrome. The presence of associated precipitating factors for deep venous thrombosis listed above lends strong support to its diagnosis.

B. Diagnostic Testing

I. D-Dimer

The measurement of the degradation products of cross-link fibrin (D-dimer) circulating in the bloodstream is a highly sensitive but nonspecific screening test for suspected venous thromboembolism. D-dimer is measured by enzyme-linked immunosorbent assay (ELISA). A negative test result, however, provides reassurance in more than 90% of cases that a serious event such as pulmonary

embolism is not present. Clinical studies indicate that deep venous thrombosis can be ruled out in a patient who is judged clinically unlikely to have deep vein thrombosis and who has a negative D-dimer test.

2. Ultrasonography

Compression ultrasonography carried out by experienced technicians is accurate in detecting above-the-knee thrombosis in patients who are symptomatic. An incomplete obstruction or small clots may not be detected. The test is sensitive and fairly specific in symptomatic patients, but in asymptomatic patients the sensitivity is only 59%. In addition, this highly touted test does not adequately visualize the deep veins of the calf or pelvis.

3. Venography

Venography is the investigation of choice for patients with indeterminate diagnosis from ultrasound, D-dimer, and the probability from clinical assessment by a physician. An algorithm for the diagnosis of the deep vein thrombosis is given in Fig. 1. Not all scenarios are covered by algorithms, however.

IV. MANAGEMENT

A. Heparin

All patients with proven deep vein thrombosis are treated with heparin for days and sometimes weeks followed by oral anticoagulants. The goals of therapy are to prevent pulmonary embolism, restore venous patency and valvular function in veins, and to prevent postphlebotic syndrome.

For the past 40 years or more intravenous heparin has been the standard therapy used for several days before commencing oral anticoagulation with warfarin. During the past few years, however, clinical trials have shown that low molecular weight heparin (LMWH) given subcutaneously provides the same protection as intravenous heparin. Most important, these agents can be used in the home avoiding expensive hospitalization.

B. Prophylaxis

The prevention of deep vein thrombosis in patients undergoing hip and knee surgery is vital. These patients should be treated with LMWH, such as enoxaparin administered approximately 6 h after surgery and continued for 2–3 weeks. In Europe LMWH is often administered

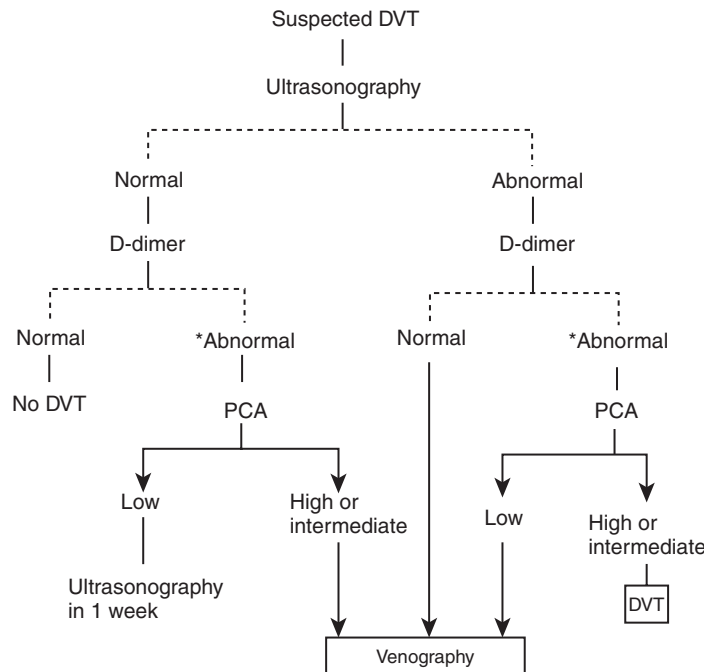

FIGURE 1 Algorithm for the diagnosis of deep venous thrombosis (DVT). PCA = probability from clinical assessment; * = exclude myocardial infarction, congestive heart failure, pneumonia, cancer, post surgery. (From Khan, M. Gabriel (2001). *On Call Cardiology*, 2nd ed., Philadelphia: W. B. Saunders, p. 360.)

approximately 12 h prior to surgery. This strategy has recently evolved. A study by Hull using LMWH approximately 6h after surgery provided significant efficacy over oral anticoagulants without increased risk of bleeding. This strategy reduced the risk of all deep vein thrombosis by 50% and reduced the risk of proximal (above-the-knee) deep vein thrombosis by 72% ($p < 0.001$). Other trials indicate that the best effects are achieved when deep vein thrombosis prophylaxis is initiated close to surgery.

BIBLIOGRAPHY

- Bengt, I., Eriksson, Bergqvist, D., Käleboet, P. et al. Ximelagatran and melagatran compared with dalteparin for prevention of venous thromboembolism after total hip or knee replacement: the METHRO II randomised trial. *Lancet*, 360:1441, 2002.
- Colwell, C. W., Collis, D. K., Paulson, R. et al. Comparison of enoxaparin and warfarin for the prevention of venous thromboembolic disease after total hip arthroplasty. Evaluation and human hospitalization three months after discharge. *J. Bone Joint Surg.*, 92:81–8, 1999.
- Goldhaber, S. Z., Turpie, A. G. G. et al. Prevention of venous thromboembolism among hospitalized medical patients. *Circulation*, 111:e1–e3, 2005.
- Hull R. D., Pineo, G. F., Francis, C. et al. Low-molecular-weight heparin prophylaxis using dalteparin in close proximity to surgery vs. warfarin in hip arthroplasty patients: A double-blind, randomized comparison. North American Fragmin Trial Investigators. *Arch. Intern. Med.*, 160:2199–2207, 2000.
- Kelly, J., and Hunt, B. J. Role of D-dimers in diagnosis of venous thromboembolism. *Lancet*, 359:456–57, 2002.
- Khan, M. Gabriel. *On Call Cardiology*, 2nd edition, W. B. Saunders, Philadelphia, 2001, pp. 357–71.
- Kucher, N., Koo, S., Quiroz, R. et al. Electronic alerts to prevent venous thromboembolism among hospitalized patients. *N. Engl. J. Med.*, 352:969–977, 2005.
- Scurr, J. H., Machin, S. J., Bailey-King, S. et al. Frequency and prevention of symptomless deep-vein thrombosis in long-haul flights: A randomised trial. *Lancet*, 357:1485–89, 2001.
- Wells, P. S., Anderson, D. R., Rodger, M. et al. Evaluation of D-dimer in the diagnosis of suspected deep vein thrombosis. *N. Engl. J. Med.*, 349:1227–35, 2003.

Depression and the Heart

I. Pathophysiologic Mechanisms II. Drug Management

DEPRESSION IS COMMON IN PATIENTS WITH coronary artery disease and is believed to confer an increased cardiac risk on healthy individuals and on patients with known coronary artery disease. It is stated by some that the degree of risk with major depression appears to be comparable to that observed with other known risk factors and is largely independent of them. Nonetheless, this association needs careful documentation to ascertain what is fact and what is fiction. A few studies indicate that after a heart attack significant depressive features are found in approximately 33% of patients, and major depression is observed in about 15% of these individuals. Other studies indicate symptoms of depression and anxiety after myocardial infarction with rates ranging from 17–37%. Symptoms often persist over the ensuing months and adversely affect the patient's quality of life, but there is no documentation of increased cardiac mortality. The risk of depression is twice as high in women compared with men.

Further studies are required because of the variable reports.

1. Depressed mood was observed to be a significant predictor of subsequent fatal and nonfatal heart attacks in a prospective study of 2832 healthy adults.
2. Over a 15-year observation in 2573 adults, however, depression was not associated with increased risk of coronary events.
3. In a study by Lesperance et al., a total of 896 post myocardial infarction (MI) patients were administered the Beck Depression Inventory during admission and at one year. The severity of depression symptoms during admission was directly linked to the five-year mortality. The greater the depression the higher the five-year mortality. Even though the one-year scores were also linked to five-year cardiac mortality, most of the impact was explained by baseline scores. The authors concluded that the severity of depression symptoms

during admission rather than the changes in depression symptoms at one year was more closely linked to long-term survival.

4. Lane et al. indicated that “the balance of evidence and argument suggests that it is right for one to be skeptical about a causal link between mood, whether anxiety or depression, after MI and subsequent cardiac events and mortality.”
5. In a study by Gottlieb et al., 48% of patients with heart failure scored as depressed.

I. PATHOPHYSIOLOGIC MECHANISMS

Autonomic arousal with hyperactivity of the hypothalamic–adrenocortical and sympathoadrenal axis is provoked by depression. This axis increases corticosteroids and results from this hyperactivity are believed to stimulate the atherosclerotic process that leads to obstruction of coronary arteries. This stimulates the process and increases blood cholesterol and free fatty acids. Norepinephrine secretion is increased and catecholamine surge may cause an increase in blood pressure. Depressed cardiac patients have been shown to have diminished heart rate variability caused by a relative increase in sympathetic tone. This increases the risk for serious and sometimes life-threatening abnormal heart rhythms. Small blood particles such as platelets and coagulation factors are activated by serotonin and this may contribute to the increased risk of MI.

II. DRUG MANAGEMENT

Recent studies indicate that selective serotonin reuptake inhibitors (SSRIs) constitute a major advance in the management of depressed patients with heart disease. Randomized controlled trials are required to document their beneficial effects over a 5- to 7-year period. The antidepressant heart attack randomized trial (SADHART) studied 370 patients with acute MI or unstable angina

and major depressive disorder. After a two-week placebo run, patients were randomized to receive sertraline (Zoloft), 50 mg daily or placebo for 24 weeks. Approximately 33% of these patients had previous episodes of depression. Results indicated that sertraline was effective in treating patients with more severe, recurrent episodes of depression. This drug did not cause adverse cardiac effects, for example, changes in left ventricular ejection fraction or other cardiac measurements. The incidence of the cardiovascular events was less frequent in this group, and 22.4% versus 14.5% in the placebo group. This difference did not reach statistical significance, but it is reassuring that no adverse cardiac effects were observed and depression was significantly ameliorated. This was a short-term study and trials to observe whether these agents reduce cardiac mortality long-term are necessary.

The Canadian Cardiac Randomized Evaluation of Antidepressant and Psychotherapy Efficacy (CREATE) is in progress with patients randomized to four arms. Patients either received citalopram (Celexa), and interpersonal psychotherapy, placebo and interpersonal psychotherapy, routine clinical management, or routine clinical management and placebo. Other agents in this group include fluoxetine (Prozac), the serotonin antagonist mirtazapine (Remeron), and the norepinephrine- and dopamine-reuptake inhibitor bupropion (Wellbutrin). These drugs may cause significant increase in blood pressure and should be avoided in patients with hypertension or ischemic heart disease manifested by angina or heart attack.

Serotonin antagonists and reuptake inhibitors: nefazodone (Serzone), trazodone (Desyrel). These agents The

bicyclic venlafaxine (Effexor) may cause hypertension, Serotonin and norepinephrine reuptake inhibitors. Tricyclic antidepressants (amitriptyline, imipramine, doxepin, desipramine). These older antidepressants are well known to have adverse cardiac side effects and are contraindicated in patients with heart disease.

BIBLIOGRAPHY

- Blumenthal, J. A., Lett, H. S., Babyak, M. A. et al. Depression as a risk factor for mortality after coronary artery bypass surgery. *Lancet*, 362: 604–09, 2003.
- Bonnet, F., Irving, K., Terra, J. L. et al. Anxiety and depression are associated with unhealthy lifestyle in patients at risk of cardiovascular disease. *Atherosclerosis*, 178:339–344, 2005.
- Ellis, J. J., Eagle, K. A., Kline-Rogers, E. M., Erickson, S. R. et al. Depressive symptoms and treatment after acute coronary syndrome. *Int. J. Car.*, 99:443–447, 2005.
- Gottlieb, S. S., Khattha, M., Friedman, E. et al. The influence of age, gender, and race on the prevalence of depression in heart failure patients. *J. Am. Coll. Cardiol.*, 43:1542–1549, 2004.
- Lane, D., Carroll, D., and Lip, G. Y. H. Anxiety, depression, and prognosis after myocardial infarction: Is there a causal association? 42:1808–1810, 2003.
- Lesperance, F., Frasere-Smith, N., Talajic, M. et al. 5-year risk of cardiac mortality in relation to initial severity and 1-year changes in depression symptoms after myocardial infarction. *Circulation*, 105:1049–1053, 2002.
- Mallik, S., Krumholz, H. M., Lin, Z. Q. et al. Patients with depressive symptoms have lower health status benefits after coronary artery bypass surgery. *Circulation*, 111:271–277, 2005.
- Rumsfeld, J. S., Ho, P. M. et al. Depression and cardiovascular disease: A call for recognition. *Circulation*, 111:250–253, 2005.
- Whooley, M. A., and Simon, G. E. Managing depression in medical patients. *N. Engl. J. Med.*, 343:1942–49, 2000.

Diabetes and Cardiovascular Disease

- I. Size of the Problem
- II. Clinical Features and Complication of Type 2 Diabetes
- III. Pathogenesis of Type 2 Diabetes and Research Implications
- IV. Maturity Onset Diabetes of the Young
- V. Management of Type 2 Diabetes
- VI. Hyperglycemic Hyperosmolar Coma
- VII. Dyslipidemia in Type 2 Diabetes
- VIII. Clinical Studies, Type 2 Diabetes
- IX. Coffee Consumption and Risk of Type 2 Diabetes
- X. Insulin Resistance
- XI. Type 1 Diabetes

GLOSSARY

- atheroma** same as atherosclerosis, raised plaques filled with cholesterol, calcium, and other substances on the inner wall of arteries that obstruct the lumen and the flow of blood; the plaque of atheroma hardens the artery, hence the term atherosclerosis (sclerosis = hardening).
- cardiomyopathy** heart muscle disease.
- edema** accumulation of fluid.
- endothelial dysfunction** endothelium (lining of the arteries) is influenced by many substances some of which derange the function of the endothelial cells.
- hyperglycemia** high blood glucose levels.
- hypoglycemia** low blood glucose.
- macrovascular damage** damage to arteries, arterioles (small arteries), and small vessels.
- microvascular damage** damage to capillaries.
- vasodilatory** dilatation of the lumen of arteries or veins; this increases blood flow.
- visceral adiposity** marked accumulation of fat that covers the abdominal organs, often termed abdominal obesity; the fat around the waistline also covers the internal organs within the abdomen.

I. SIZE OF THE PROBLEM

A. Incidence

Presently there are more than 16 million type 2 diabetics in the United States, and it is expected that this number will rise to approximately 22 million adults with diabetes in the year 2025. In addition, there are greater than 40 million individuals who may not satisfy strict criteria for the diagnosis of diabetes but have normal or minimally elevated blood glucose levels with associated hyperinsulinemia and peripheral insulin resistance. These “prediabetic” individuals have a 10% annualized risk of developing type 2 diabetes. Importantly, most diabetics die of cardiovascular disease, and atherosclerosis that causes obstruction to arteries in the heart and brain accounts for greater than 80% of all diabetic mortality.

Worldwide the incidence of diabetes differs greatly. Indians living in India have a much higher rate of diabetes than those Indians observed in the United States. This incidence is increased after Indians immigrate from their country, and here they have been shown to have a higher rate of diabetes than other ethnic groups. This well-recognized observation has been noted in Indians living in Singapore, South Africa, Malaysia, Fiji, and Trinidad. The prevalence of diabetes is greater than 35% among Pima Indians versus approximately 4% in the non-Pima Indian population in the United States. In randomized clinical trials conducted in the United States that involve patients with heart disease, stroke, or cardiovascular diseases, greater than 20% are diabetics, however. The Chinese and Eskimos have a much lower prevalence of diabetes.

Type 1 diabetes (commonly known as insulin-dependent diabetes and juvenile diabetes) occurs mainly in younger individuals aged 10–14 years and comprise about 10% of all cases of diabetes, that is, a prevalence of approximately 0.3%. Type 1 diabetes is not a disorder limited to young people, however. Recent studies support a different model in which the disease can occur at any age.

These two types of type 1 diabetes have a different causation and symptoms, signs, and treatment are markedly different. It is interesting that type 1 diabetes is extremely rare in Pima Indians, Eskimos, and Micronesians, but it is more common in Caucasian populations (see Section III).

B. Diabetic Distress

The distressing news is that greater than 25% of all new cases of severe renal failure occur in patients with diabetes, and this serious complication develops 25 years earlier than in nondiabetics, most of whom will never have renal failure (see Fig. 1). More than 25,000 amputations mainly of toes feet and legs are carried out in patients with diabetes, and diabetes is the leading cause of new cases of blindness with greater than 5000 cases occurring annually in the United States.

Because the optimal treatment of diabetes by the medical profession does not prevent the occurrence of fatal and nonfatal heart attacks and only mildly retards the onset of renal failure, stroke, and peripheral vascular disease, diabetics have a poor prognosis. The problem is immense and there is very little hope in sight. New

research avenues must be sought by those who are motivated to do genuinely meaningful research.

II. CLINICAL FEATURES AND COMPLICATION OF TYPE 2 DIABETES

A. Symptoms of Type 2 Diabetes

Below is a list of symptoms of type 2 diabetes.

1. Polyuria (elimination of excessive volumes of urine, two to four-times daily normal voiding amounts); this may be present for several weeks or months before noted as an abnormality by an individual
2. Polydipsia (excessive thirst)
3. Polyphagia (excessive ingestion of food, particularly sweets and chocolates)
4. Weakness, fatigue, and lethargy
5. Weight loss occurs frequently, but in the Western world more than 80% of patients are overweight or obese at onset; minimal weight loss may occur in these overweight individuals followed by failure to lose weight
6. Headache, dizziness, and blurred vision
7. Urinary infections, carbuncles, boils, failure of small lesions to heal normally, and fungal infections of the nails and groin
8. Tingling and numbness in the feet due to neuropathy (nerve damage)
9. Swelling of the ankle and lower legs caused by edema
10. In many individuals no symptoms or only minor symptoms that go unnoticed occur

B. Diagnosis

I. Definition

The definition of diabetes based on the glucose levels is given in Table 1. An algorithm for screening for diabetes is given in Fig. 2. Recommended diagnostic and screening tests include a fasting glucose level. After an 8-h fast, a fasting plasma glucose greater than 126 mg/dl (mmol/L) establishes the diagnosis of diabetes mellitus. A fasting glucose of less than 110 mg/dl is considered normal and levels between 110 and 125 mg/dl refer to impaired fasting glucose. Two hours following an oral administration of 75 g of glucose, a plasma glucose level greater than 140 mg/dl is diagnostic and a level less than 200 mg/dl is considered impaired glucose tolerance (IGT).

According to criteria developed by the National Diabetes Data Group, the presence of any of the classic symptoms such as polyuria and polydipsia, ketonuria, and

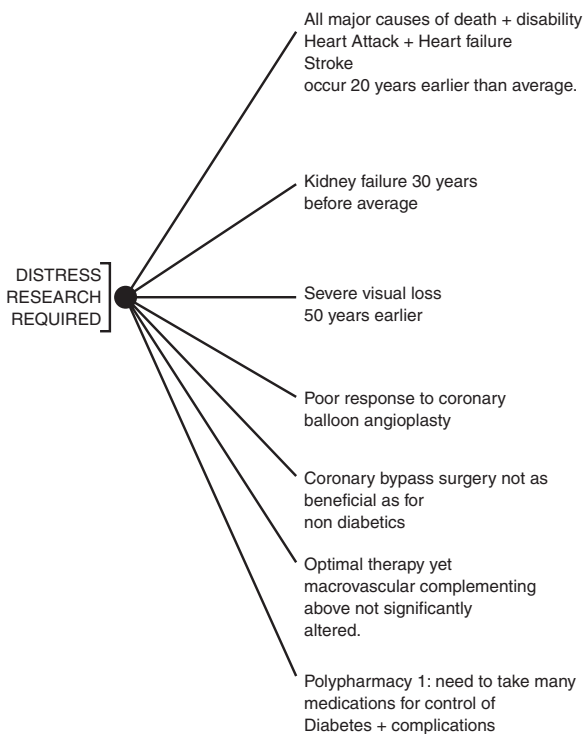

FIGURE I Diabetics in distress.

TABLE I
Definition of Diabetes

	Fasting glucose [mg/dl (mmol/L)]	Peak glucose [mg/dl (mmol/L)]	2 Hour glucose [mg/dl (mmol/L)]
Normal	<110 (6.1)	<200 (11.1)	<140 (7.8)
Impaired glucose tolerance IGT	110–125	>200 (11.1)	140–200 (7.8–11.1)
Diabetes mellitus	≥126 (7.1)	GLX not needed	
Diabetes mellitus*			≥200 (11.1)
Normal	—	—	<140 (7.8)
IGT	—	—	140 to <250

* GGL = 2 hr glucose post load

The test should be done:

- after 3 days of a diet supplying more than 150 g of carbohydrates per day
- in the morning after a 10–14 hour fast
- with the patient lying down or sitting in a quiet room, without smoking
- blood glucose 2 hr following 75 g oral glucose load
- mmol/L factor 0.05551

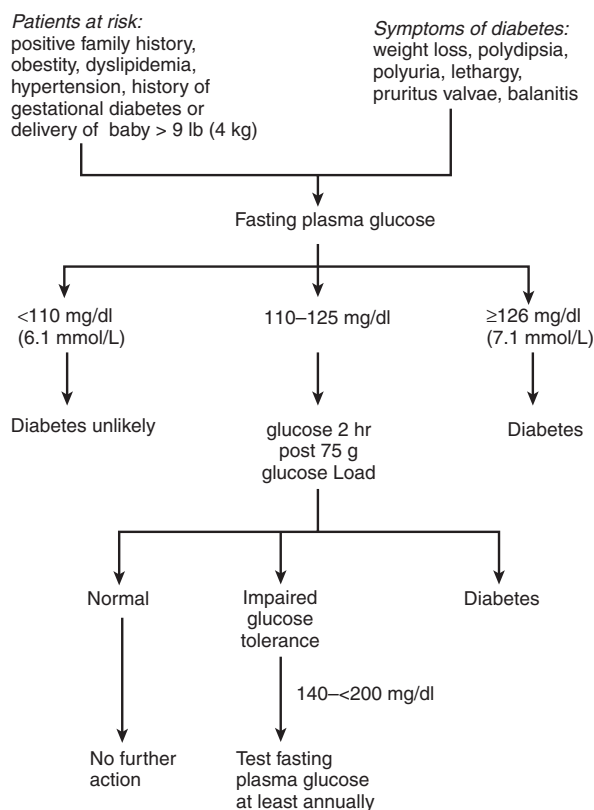

FIGURE 2 Screening for diabetes.

rapid weight loss, together with a random venous plasma glucose level greater than 200 mg/dl (11.1 mmol/L) are considered diagnostic of diabetes.

IGT is also considered diagnostic of diabetes. Individuals with a high IGT have plasma glucose levels higher than normal but lower than those considered diagnostic

for diabetes mellitus. Of all patients with high IGT, 1–5% a year develop overt diabetes mellitus. Individuals with IGT have a greater than normal risk for macrovascular complications, but do not appear to have an increased risk for the more benign microvascular complications of diabetes.

C. Features

The characteristic features of type 1 and type 2 diabetes are given in Table 2. Complications of diabetes are illustrated in Fig. 3. The discussion of type 1 diabetes will follow the discussion below of type 2 diabetes.

III. PATHOGENESIS OF TYPE 2 DIABETES AND RESEARCH IMPLICATIONS

Type 2 diabetes is a term to be used for idiopathic forms of diabetes with insulin resistance and without severe insulin deficiency or dramatic loss of beta cells. It has recently been appreciated that approximately 5–25% of patients initially diagnosed with type 2 diabetes actually have type 1 diabetes. Very little research can be done in medicine without a thorough knowledge of the pathogenesis and the pathophysiology of the disease process. Figure 4 depicts pathophysiology and metabolic abnormalities).

A. Insulin Secretion

Regulation of insulin secretion is influenced by plasma levels of glucose. This level is the most important stimulus for insulin secretion (see Fig. 5). Glucagon secretion and

TABLE 2
Characteristic Features of the 2 Main Types of Diabetes Mellitus

	Type I: insulin-dependent diabetes mellitus (IDDM)	Type II: noninsulin-dependent diabetes mellitus (NIDDM)
Prevalence	10%	90%
Age of onset	Typically onset <30 years but any age possible	Onset usually >40 years
Body weight	Usually thin	>80% obese
Presentation	Acute onset, with polyuria, polydipsia, weight loss, lethargy, pruritus vulvae, balanitis	Insidious onset, micro- and macrovascular complications may be present at diagnosis
Etiology	Inadequate insulin secretion due to autoimmune destruction of the pancreatic β -cells	Impaired insulin secretion, increased hepatic glucose production and peripheral insulin resistance
Ketosis	Prone	Not prone
Genetics	HLA-DR3 and DR4 common; 50% concordance in identical twins	HLA unrelated; 100% concordance in identical twins
Circulating islet cell antibodies	Yes	No
Treatment with insulin	Always necessary	Usually not required
Insulin secretion	Severe deficiency	Variable moderate deficiency to hyperinsulinemia
Insulin resistance	Occasional with poor control on aggressive insulin antibodies	Usual: caused by receptor and post receptor defects

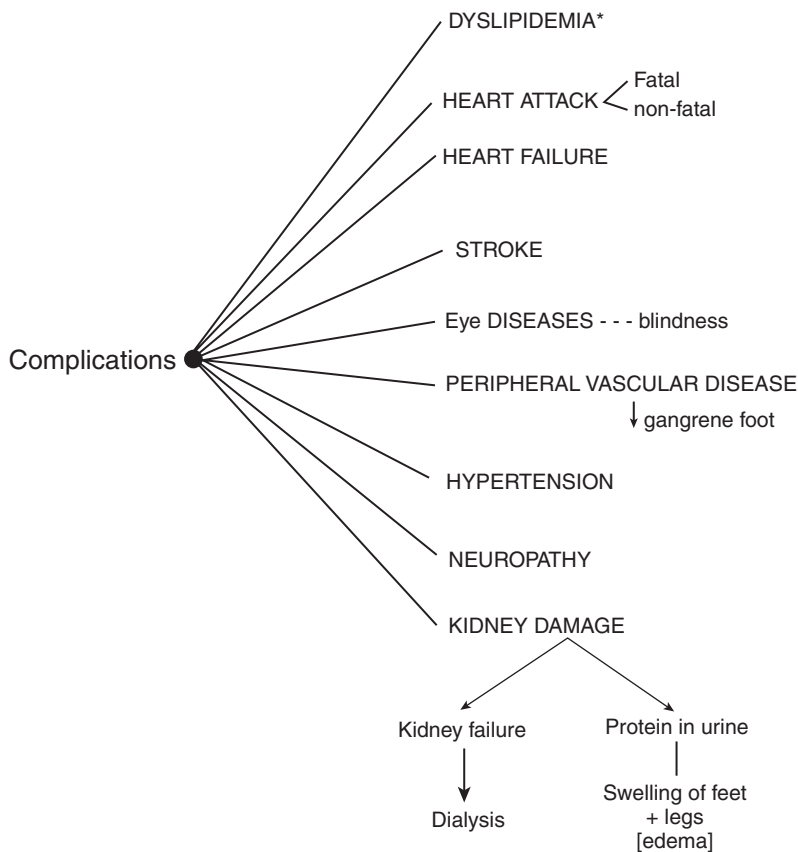

FIGURE 3 Complications of diabetes. *See chapter entitled Dyslipidemia.

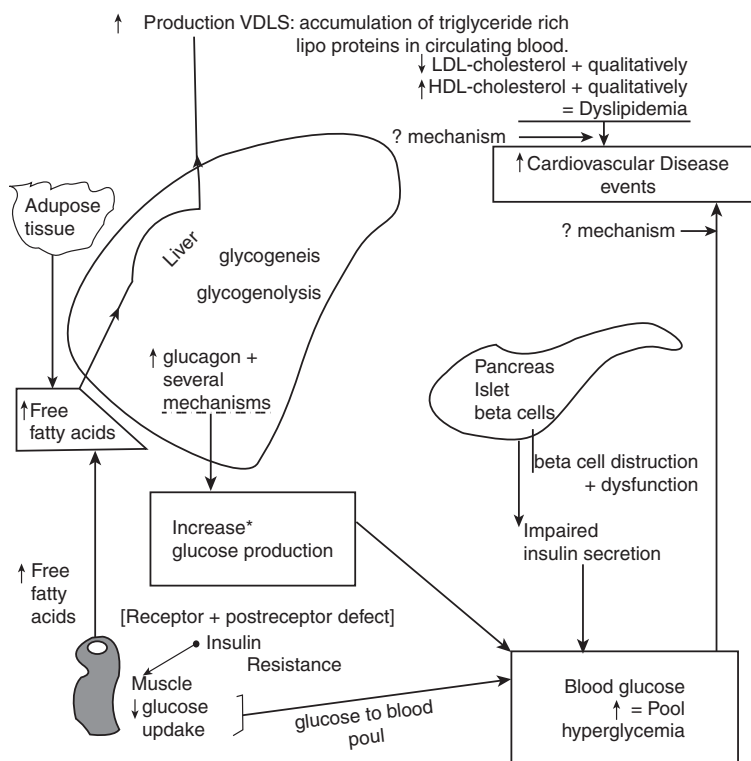

FIGURE 4 Diabetes mellitus pathophysiology and metabolic abnormalities. *Note increase production: how to halt this? New concepts.

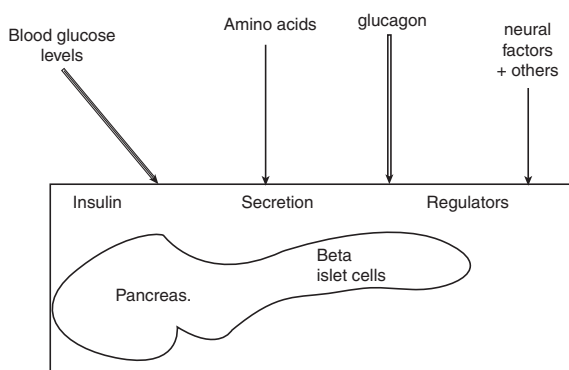

FIGURE 5 Factors that influence glucose levels and insular secretion normally and in type II diabetes. Mechanisms may dictate where to attack for development of new therapies.

amino acids are also important. Neural influences, gut insulinogenic hormones, and other factors appear to be of minor importance.

B. Underlying Mechanisms

The great majority of patients with type 2 diabetes have four major defects (see Fig. 4):

1. Insulin deficiency caused by a decline in pancreatic beta cell function

2. Insulin resistance because of a deficiency of cell surface insulin receptors (see Fig. 4)
3. Increased hepatic glucose production (see Fig. 4)
4. Glucagon secretion is increased

The major mechanism of hepatic glucose production is not emphasized in medical textbooks and in the scientific literature. Although it is crucial for diabetics to maintain stringent diets that lower blood glucose levels and drugs are used to increase insulin secretion from the pancreas (a host of old and new sulfonylureas), it appears that inhibition of glucose release by the liver has escaped the attention of researchers. In addition, agents similar to metformin and new agents that may overcome insulin receptor deficiency may have a role. Most of the glucose in the plasma is produced by the liver. Thus, one approach for the control of glucose levels in type 2 diabetes is to limit hepatic production of glucose.

Excess glucagon secretion contributes significantly to increased glucose production. Decreased insulin secretion and resistance as well as increased glucagon secretion are major players in the pathogenesis of type 2 diabetes. Perhaps future glucagon receptor blockers can be developed (see Figs. 4 and 6).

It appears that the medical profession has concentrated mainly on hepatic glucose production. Most

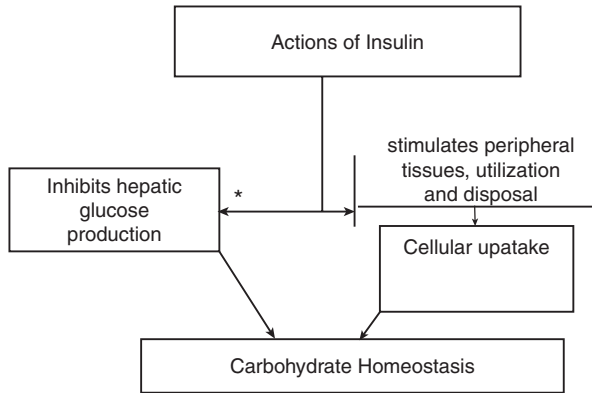

FIGURE 6 Basic actions of insulin simplified. *Therefore type II diabetes best treated with insulin to inhibit glucose production: sulfonylureas are not effective.

diabetologists agree that hyperglycemia contributes substantially to complications, but they concentrate on reducing blood glucose by diet and drugs that have a modest effect on increasing insulin secretion from dysfunctional beta islet cells. They also employ the use of the agent, metformin, which has minimal effects on peripheral uptake of insulin. Insulin action inhibits some of the release of hepatic glucose but other agents must be sought. Agents that can overcome insulin resistance at receptor sites are important in future diabetes treatment.

C. Effects of Insulin

Insulin is a hormone that binds to specific cell surface insulin receptors. It stimulates peripheral glucose uptake and disposal by cells in all regions of the body. It further inhibits hepatic glucose production and plays a key role in carbohydrate homeostasis (see Figs. 4 and 6).

D. Mechanisms of Vascular Abnormalities in Diabetes Mellitus

Important causes of vascular abnormalities in diabetes mellitus include hyperglycemia. This leads to an increased concentration in the cell of the metabolite diacylglycerol which is an activator of a family of enzymes called protein kinase C (PKC). These enzymes perform key regulatory functions by phosphorylating proteins and are now believed to play a significant role in the pathophysiology of cardiovascular complications. It is well known that nitric oxide synthase enhances arterial endothelial vasodilatory function and activation of PKC can inhibit expression, although a nitric oxide synthase can inhibit beneficial vasodilatory function. Glucose-induced activation of PKC

has been shown to increase the production of extracellular matrix macromolecules that accumulate during atheroma formation.

A selective inhibitor PKC-beta given to diabetic rats has been shown to improve retinal blood flow. These enzymes appear to be implicated in muscle dysfunction and cardiomyopathy in diabetes. Intensive research is being pursued in this interesting direction. Hyperglycemia causes an overproduction of oxygen-derived free radicals that promotes endothelial cell dysfunction. It appears that the antioxidant effect of high doses of vitamin C improves endothelial-dependent vasodilatation in diabetic individuals. Hyperglycemia impairs endothelial-dependent vasodilatation, and this deleterious effect is also caused by dyslipidemia. Treatment with fibrates or statins improves endothelial function.

Hyperglycemia also leads to the production of sorbitol, which can be converted to fructose. Accumulation of sorbitol and fructose increases intracellular osmolarity with water influx and swelling of nerve cells. This may explain why diabetics have damage to their peripheral nerves.

E. Dyslipidemia

Dyslipidemia or hyperlipidemia is the most substantiated mechanism involved in progressive atheroma formation in the process of obstructing atherosclerosis. The dyslipidemia that is common in type 2 diabetes is generated by increased hepatic production of very low density lipoproteins (VLDLs; see Fig. 4).

1. Free Fatty Acids

In type 2 diabetes there is increased delivery of fatty acids to the liver. Striated muscle takes up less free fatty acids because of insulin resistance and excess free fatty acids are delivered to the liver. Insulin resistance plays an important role in type 2 diabetes and this role should be quantified. Agents that decrease insulin resistance should be developed.

Central abdominal obesity or visceral adiposity drains directly into the portal vein that leads to the liver. Visceral adiposity is therefore an important root of diabetic dyslipidemia, because it increases the delivery of free fatty acids to the liver.

Free fatty acids are the substrate for liver synthesis of VLDLs. These particles carry endogenously produced triglycerides and have a particle diameter ranging from 300 to 800 nm. An abundance of triglyceride-rich lipoproteins accumulate in the plasma. Additionally, in uncontrolled type 2 diabetes lipoprotein lipase activity is decreased resulting in the failure of clearing triglyceride-rich

particles derived from food intake. The abundance of VLDLs in the plasma provides an increase in substrate for cholesterol ester transfer protein which causes a flux of cholesterol from HDL particles. This decreases the level of HDL cholesterol in the blood.

Fenofibrate, a thiazolidinedione, has been shown to improve insulin sensitivity by activating peroxisomal proliferation-activating receptor gamma (PPAR-gamma). In the Veterans Affairs (VA) high-density lipoprotein cholesterol intervention trial, patients who have a lipoprotein profile of insulin resistance were treated with a fibrate which showed a reduction in coronary heart disease events and stroke. Also, the Diabetes Atherosclerosis Intervention Study (DAIS), showed delayed angiographic progression of coronary atherosclerosis in diabetic patients treated with fenofibrate.

2. High-Density Lipoproteins

High-density lipoproteins (HDLs) mainly carry cholesterol ester and are small particles with a diameter of 50–90 nm. HDL is *believed* to be protective in cardiovascular disease probably because of a number of potential mechanisms including reverse cholesterol transport. The protective effect of HDL is believed to result from its ability to reduce the oxidation of LDL cholesterol. Also, in diabetics the HDL particle appears to be qualitatively different and provides less protection from oxidation (see Fig. 4).

3. LDL Cholesterol

LDL cholesterol carries the bulk of circulating cholesterol, and its main component is cholesterol ester. The LDL particle has a diameter of 180–280 nm and is highly atherogenic. It is believed to be the main particle involved in producing atheroma in uncontrolled diabetics. The LDL particles have qualitative differences (see Fig. 4). They are smaller and denser particles in diabetics and show greater susceptibility to oxidation compared with nondiabetics. LDL cholesterol is mild to moderately increased in diabetics and treatment with statins has shown a decrease in risk of coronary events.

F. Defect in Fibrinolysis and Thrombosis

An increased level of fibrinogen and plasminogen activator inhibitor type 1 (PAI-1) has been detected in plasma and in arterial lesions in patients with diabetes. Platelet function is also abnormal. These defects in the coagulation

system are believed to increase the incidence of thrombosis and perhaps, the atherosclerotic process.

G. Genetic Abnormalities

A specific mutation that causes insulin-resistant diabetes mellitus and hypertension has been defined in a small number of individuals. PPAR-gamma mutations have been noted in members of two young affected kindreds.

IV. MATURITY ONSET DIABETES OF THE YOUNG

Maturity onset diabetes of the young (MODY) is a clinically heterogeneous group of disorders characterized by an autosomal dominant mode of inheritance and onset usually before age 25. It is a primary defect in the function of the beta cells of the pancreas. Mutations in any one of six different genes may result in MODY.

These genes are expressed in beta cells, and mutation of any of them leads to beta cell dysfunction and diabetes mellitus. Fortunately individuals with MODY do not usually develop ketotic diabetes mellitus, which occurs frequently in type 1 diabetes.

V. MANAGEMENT OF TYPE 2 DIABETES

Initially, therapy for diabetes includes special diets to reduce carbohydrate intake and thus blood glucose and weight reduction. Anti-diabetic drugs are the next of course of action.

A. Drugs

I. Drugs to Increase Insulin Production by the Pancreas

Included in this group are the sulfonylureas such as glyburide, glipizide, gliclazide, and glibenclamide. These agents have been used for more than 50 years. The well-known agents used in the 1950s, tolbutamide and chlorpropamide, have been replaced by the new agents listed above. Several other agents are now available, but they are far superior to the old agents. Additionally, sulfonylureas are relatively ineffective drugs because they are not able to squeeze sufficient insulin from dysfunctional pancreatic beta islet cells. There may also be some cardiotoxic effect with prolonged use. The use of sulfonylureas over the past 30 years has not altered the prognosis of diabetes and its

complications (see Fig. 1). Physicians should seek other methods of treatment.

2. Drugs that Appear to Increase Peripheral Uptake of Insulin

One example is metformin. This biguanide is commonly used at a dose of 500 mg twice or three times daily with a maximum dose of 2000 mg daily, but physicians often exceed this maximum dose. Metformin has interesting actions and there is potential for developmental research in this area.

This drug acts primarily on hepatic glucose production. The reduced hepatic glucose output is caused mainly by inhibition of gluconeogenesis. The exact mechanism through which metformin reduces hepatic glucose production as well as its effectiveness in the suppression of gluconeogenesis remain unclear. The primary site of action appears to be the hepatocyte mitochondria, where the drug disrupts respiratory chain oxidation of complex substrates such as glutamate, lactate, pyruvate, glycerol, and amino acids. There is, however, minimal effect on the splitting up of glycogen in the liver-yielding glucose (glycogenolysis).

Metformin possesses some effects on peripheral insulin sensitivity. This would be an extremely useful action of the drug, but its effect is minimal and mainly in insulin-sensitive tissues. The drug's effect on peripheral insulin-sensitive tissues requires the presence of insulin for its full action. In insulin-sensitive tissues such as skeletal muscle the drug facilitates glucose transport by increasing tyrosine kinase activity in insulin receptors and enhances glucose transporter trafficking to the cell membrane. It is claimed that metformin improves insulin resistance, which is an important mechanism in type 2 diabetes. But review of its actions indicates only a minimal effect. Type 2 diabetic patients are insulin resistant primarily because of decreased insulin receptors. Thus metformin has a modest effect on improving insulin resistance.

Other agents to treat diabetes must be investigated. In the UK Prospective Diabetes Study Group (UKPDS) there was an increased mortality during combination therapy with metformin plus sulfonylureas despite improvement in the control of blood glucose levels with combination versus monotherapy. Was the mortality increase observed caused by sulfonylureas, metformin, or the natural course of type 2 diabetes? More research is needed in this area.

Metformin has only modest beneficial effects on lipid metabolism, clotting factors, and platelet function. This drug has been shown to improve diabetes-induced cardiac diastolic dysfunction in laboratory animals. It also appears

to improve vascular relaxation and may cause a mild decrease in blood pressure in some individuals.

Caution: This drug is contraindicated in patients with renal dysfunction (mild-to-moderate renal failure), congestive heart failure, and in patients with lung disease associated with hypoxia. In a review of prescriptions almost one-quarter of patients with a prescription for metformin had one or more contraindications. Several recent studies in Europe have documented similar rates of inappropriate prescriptions for metformin. Metformin has been associated with the development of lactic acidosis, and since its marketing in 1995, the FDA has required a black box warning in the package insert. In the first 40 months after its release in the United States, the FDA received 47 confirmed cases of lactic acidosis associated with the use of the drug with a 42% mortality. More than 90% of these patients had relative or absolute contraindications to metformin. This drug along with phenformin was used sparingly in the 1970s when the incidence and dangers of lactic acidosis became widely known. In the 1990s and recently, however, the drug has become the most widely used oral hypoglycemic agent prescribed.

Metformin is more beneficial when used along with small doses of insulin. A study of the pathogenesis and actions of hypoglycemic agents allows the conclusion that when metformin is used with insulin, the sulfonylurea that is commonly prescribed in triple therapy may not be required. This is one more drug removed from the polypharmacy that is inflicted upon diabetics. These patients must also take drugs to protect their hearts, reduce blood pressure, and protect their kidneys as well as other medications.

Metformin, however, has an important role in the management of type 2 diabetes until more effective agents are available to overcome insulin resistance and decrease hepatic production of glucose. The Diabetes Prevention Program in the United States and the Diabetes Prevention Study in Finland have recently demonstrated that lifestyle modification programs and metformin can delay the onset of diabetes in glucose-intolerant individuals.

3. Insulin

During the past five years, diabetologists have advocated the addition of insulin to the oral drugs to maintain optimal glucose levels. This is the treatment advised in diabetic clinics and general practitioners have followed these guidelines. It is unfortunate that this triple-drug regimen does not prevent the macrovascular complications of diabetes. This therapy has had no impact on the risk for coronary heart disease and fatal and nonfatal heart attacks. The combination of insulin and metformin without sulfonylureas appears to be a more logical regimen.

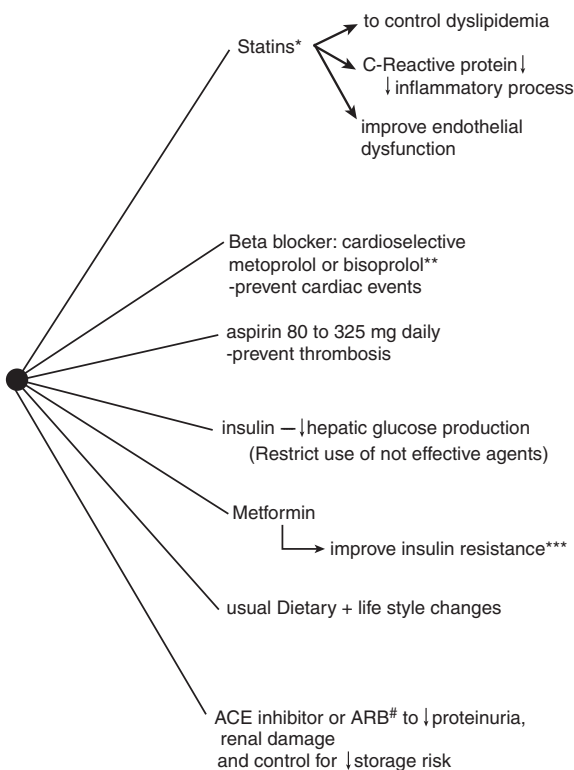

FIGURE 7 New concepts for the management of type II diabetes and research implications. *Fibrates in selected individuals triglycerids >500 mg/dL 5 mmol/L; **=See section on beta blockers for choice of agent; ***=Modest effect, need new agents to overcome resistance; # =ARB = angiotensin II receptor blocker.

4. Thiazolidinediones

These agents have a mild effect on the lowering of blood glucose levels, but it is not as effective as sulfonylureas. Troglitazone has been voluntarily withdrawal from the market because of severe hepatotoxicity. Pioglitazone and rosiglitazone are available in United States, but their use is restricted in patients with congestive heart failure. This restriction is in place because they increase retention of sodium and water which worsens heart failure. They also produce significant weight gain and they should not be prescribed to persons with familial polyposis.

Figure 7 gives concepts for the management of type 2 diabetes and research implications that may result in a decrease in cardiovascular complications.

VI. HYPERGLYCEMIC HYPEROSMOLAR COMA

This complication occurs in older patients with type 2 diabetes who cannot recognize the need for water. A

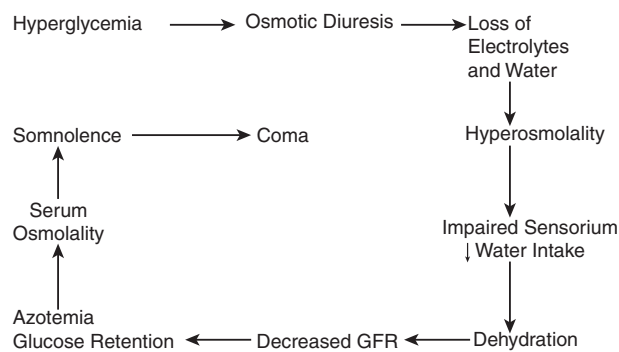

FIGURE 8 Pathogenesis of hyperosmolar state.

precipitating factor is usually present such as myocardial infarction, stroke, infection, and overzealous use of diuretics and steroids. The pathogenesis of hyperosmolar coma is shown in Fig. 8.

Hyperglycemia causes chronic osmotic diuresis which results in severe dehydration and loss of potassium and sodium. Ketosis is absent mainly because critical amounts of insulin are still present and capable of suppressing lipolysis. The blood glucose in these patients is often greater than 600 mg/dl (30 mmol/L).

Management necessitates immediate rehydration and this should be done more slowly than in patients with diabetic ketoacidosis. Most patients are quite sensitive to insulin and only small doses are required. The precipitating factors should be identified and treated.

VII. DYSLIPIDEMIA IN TYPE 2 DIABETES

A. Characteristics

Dyslipidemia is common in diabetics and is characterized by borderline (200–400 mg/dl; 2.3–4.5 mmol/L) to moderate elevations of triglyceride levels greater than 400 mg/dl (see Fig. 4). There is also an increase in total cholesterol levels to greater than 240 mg/dl with increased levels of small, dense LDL cholesterol (bad cholesterol) of greater than 160 mg/dl. Another characteristic of dyslipidemia is a low level of HDL cholesterol less than 35 mg/dl (0.9 mmol/L).

B. Management of Dyslipidemia

I. Statin Drugs

The management of this deleterious manifestation of diabetes is crucial, because cardiac events and deaths can be prevented. Patients with elevated LDL cholesterol (220–300 mg/dl), mild elevation of triglycerides (<300 mg/dl),

and lowered HDL (<35 mg/dl) are best managed with atorvastatin or rosuvastatin, because these agents are somewhat more effective than other statins in increasing HDL levels, decreasing triglycerides, and is a powerful reducer of LDL cholesterol. Other statins include simvastatin and pravastatin. These statins do not significantly reduce triglycerides and have little effect on HDL cholesterol.

2. Fibrates

Fibric acid derivatives called fibrates are useful when the LDL cholesterol levels are mildly elevated (110–140 mg/dl) and triglycerides are very high (>500 mg/dl; 5 mmol/L) and particularly when the HDL levels are very low (>0.8 mmol/L). The combination of a statin and fibrate may cause muscle damage that is associated with marked elevations of creatinine kinase in the blood. Damage to muscle or myositis may be reversible but can be extensive enough to damage to the filtration system of the kidney and cause kidney failure. This drug combination is recommended by diabetologists and used in diabetic and lipid clinics, but the author believes that this strategy is not justifiable because the combination has caused kidney failure and deaths worldwide, albeit rarely, and the FDA has not approved the combination.

3. Torcetrapib

It is most important to increase levels of HDL cholesterol it is cardioprotective. Inhibition of cholesteryl ester transfer protein (CETP) appears to be a new and most useful strategy to raise HDL cholesterol levels. Brousseau et al. conducted a small study of 19 individuals with HDL cholesterol levels <40 mg/dl (1 mmol/L). CETP inhibition by torcetrapib administered concomitantly with atorvastatin resulted in a 61 and 46% increase in HDL levels in the atorvastatin and non-atorvastatin cohorts, respectively. The 120-mg, twice daily dose of this investigational agent increased HDL cholesterol by 106%. Most diabetic patients have HDL levels less than 35 mg/dl (0.9 mmol/L); thus, it is expected that CETP inhibition would be life-saving. (see the chapters Cholesterol and Dyslipidemia.)

VIII. CLINICAL STUDIES, TYPE 2 DIABETES

A. Tuomilehto et al.

Study question: Can type 2 diabetes be prevented by interventions that affect the lifestyle of subjects at high risk for the disease?

Methods: Randomization of 522 middle-aged, overweight subjects with a mean age of 55 years and mean body mass index of 31 (weight in kilograms divided by the square of the height in meters) with impaired glucose tolerance to either the intervention group or the control group was done. Subjects in the intervention group received counseling aimed at reducing weight, total intake of fat, and an increased intake of fiber and physical activity. The diagnosis of diabetes was confirmed by a second test after an oral glucose tolerance test.

Results: At 3.2 years' follow up the cumulative incidence of diabetes after 4 years was 11% in the intervention group and 23% in the control group. A reduction in the incidence of diabetes was associated with changes in lifestyle. The loss of weight in intervention group was 3.5 ± 5.5 kg and 0.8 ± 4.4 kg in the control group.

Perspective: Lifestyle modification such as weight loss on the incidence of diabetes was substantial; the risk of diabetes was 58% lower in the intervention group. Nonetheless, individuals in the intervention group who do not continue with lifestyle modification including weight loss would eventually show biochemical evidence and complications of diabetes in subsequent years.

B. Cho et al.

Study question: Previous studies have suggested that history of diabetes and a prior heart attack confer risk for further fatal heart attacks. This study examined the duration of diabetes in relation to mortality.

Methods: Type 2 diabetes and prior heart attack in relation to mortality was examined in 51,316 men aged 40–75.

Results: During the 10 years of follow up there were 1124 deaths from coronary heart disease. The risk of death was significantly higher in individuals with prior diabetes and myocardial infarction and having both conditions is particularly hazardous. Longer duration of diabetes was a stronger predictor of death among diabetic men.

IX. COFFEE CONSUMPTION AND RISK OF TYPE 2 DIABETES

A. van Dam et al.

Study question: Metabolic studies indicate that caffeine acutely decreases sensitivity to insulin, but tolerance to caffeine can develop. Chlorogenic acid, a phenol, reduces glucose absorption and oxidative stress and inhibits hydrolysis of glucose-6-phosphate that could reduce glucose

output in the liver. Can coffee consumption decrease the risk of type 2 diabetes?

Methods: Investigation of 17,111 Dutch men and women aged 30–60.

Results: During 125,774 person-years of follow up, 386 new cases of type 2 diabetes were reported. Individuals who drank at least seven cups of coffee daily were 0.50 times as likely as those who drank two cups daily to develop type 2 diabetes ($P=0.0002$).

Conclusion: Coffee consumption was associated with a substantially lower risk of clinical type 2 diabetes.

X. INSULIN RESISTANCE

A. Abbasi et al.

Study question: To define the relationship between body mass index and insulin resistance in 314 nondiabetic, normotensive healthy volunteers.

Methods: “Insulin resistance was quantified by determining the steady-state plasma glucose concentration during the last 30 min of a 180-min infusion of octreotide, glucose, and insulin.

Results: The body mass index and steady-state plasma glucose were significantly related.

Conclusions: Insulin resistance at any given degree of obesity appears to accentuate the risk of coronary heart disease and type 2 diabetes.

B. Other Studies

A research study of interest indicates that both abnormal peridine metabolism and vascular oxidative stress are linked to coronary endothelial dysfunction in the insulin resistance subject.

In the Western Scotland Coronary Prevention Study of 5974 men, 2.6% of these men aged 45–64 developed type 2 diabetes. A 30% risk reduction for diabetes was observed among pravastatin users.

In the United Kingdom Prospective Diabetes Group Study the efficacy of intensive glucose control using a complex protocol with either insulin or sulfonylureas compared with conventional treatment failed to demonstrate definite clinical benefit in macrovascular complications in patients with type 2 diabetes.

Van Belle et al. conducted the following study.

Study question: What are the effects of coronary stenting on vessel patency and long-term clinical outcome after percutaneous coronary revascularization in diabetic patients?

Methods: There were 314 diabetic patients treated with either coronary stenting or standard balloon angioplasty (BA).

Results: At six months the rate of stenosis (27% vs. 62%; $P < 0.0001$) and occlusion (4% vs. 13%; $P < 0.005$) were lower in the stent group than in the BA group. At four years, the combined clinical end point of cardiac death and nonfatal infarction in the stent group was 14.8% vs. 26% ($P = 0.02$) and repeat revascularization was 35.4% vs. 52.1% ($p = 0.001$).

Conclusions: In diabetic patients, coronary stent implantation was associated with a highly beneficial effect at six months and at four years compared with BA.

Perspective: In the Bypass Angioplasty Revascularization Investigation (BARI), all-cause mortality was 34.7% in diabetics who underwent BA versus 19.1% for bypass surgery. In nondiabetics mortality was much lower, 9.5 and 10.3% over five years, for angioplasty and bypass surgery. The BARI study indicated that bypass surgery was superior to angioplasty in diabetics, but the study was done before the current experience with stents. In selected patients with diabetes, PCI using stents gave results that are comparable to bypass surgery as indicated in this study. In addition, diabetics undergoing PCI show significant benefit with the use of platelet glycoprotein IIb/IIIa receptor blockers.

XI. TYPE I DIABETES

A. Pathogenesis and Epidemiology

The incidence of type 1 diabetes is extremely variable among different ethnic populations. The rate of diabetes seems to be increasing in almost all populations, but the increase is highest in nations with presently low incidence. In the Zunyi region of China the incidence is 0.1 per 100,000 per year, but it is 40 per 100,000 in Finland and in Sardinia about 3000 km away. But the incidence in neighboring Estonia is about one-quarter that of Finland.

These differences within ethnic groups, perhaps, lies in differences in environment or in genes. Estimates suggest that the incidence of type 1 diabetes may become 40 times higher in 2010.

In an excellent review Atkinson et al. stated that the genetics of type 1 diabetes cannot be classified according to a specific model of dominant, recessive, or intermediate inheritance of a specific set of genes. The disorder is heterogenous and polygenic with approximately 20 of non-HLA loci contributing to disease susceptibility that is already identified.

Results of considerable environmental research throw doubt on the implication of Coxsackie and cytomegalo

viruses, breast-feeding versus early introduction of a cow's milk, and vaccines. But the Finnish reports suggest the potential for such associations. The current view is that penetrance and expression of heritable immune dysregulation in association with target organ defects interact with environmental factors, which include infectious agents toxins, vaccines, sanitation, and others. Atkinson et al. emphasized that type 1 diabetes has increased dramatically over the past few decades, perhaps due to improved health care and sanitation.

A great percentage of children develop anti-islet autoantibodies between 1 to 3 years and those who progress to the diabetic state express multiple anti-islet autoantibodies by the time of diabetes onset. It appears that approximately 15% of patients with type 2 diabetes have what is called

latent autoimmune diabetes in adults (LADA), and these individuals express the islet autoantibodies that include glutamic acid decarboxylase (GADA).

B. Pathologic Features

The islet cells are observed to be infiltrated with mononuclear cells with reduction in beta cell volume and some degree of insulinitis. There is suggestive evidence that an interaction between Fas on beta cells and Fas ligand on infiltrating cells might trigger selective apoptotic beta cell death in inflamed islets which results in type 1 diabetes. This pathogenesis and pathophysiology lacks clarity, thus, preventive treatment remains obscure (see Fig. 9). The

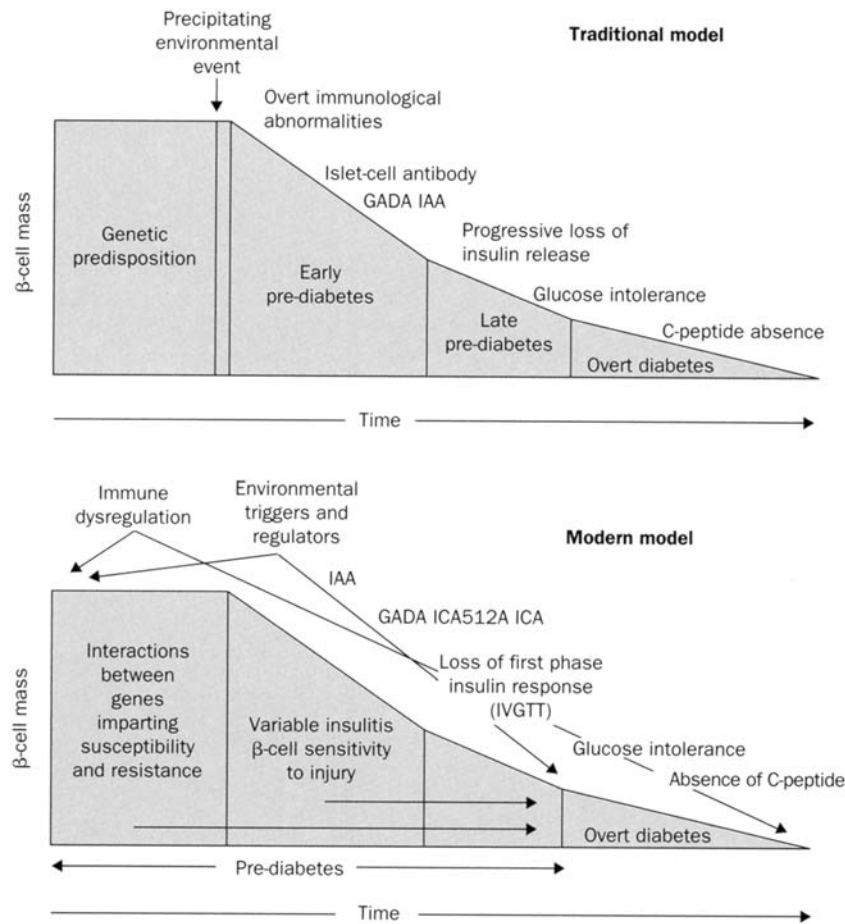

FIGURE 9 The treatment for type 1 diabetes. Many studies from animal models of type 1 diabetes in combination with a much more limited series of investigations in human beings suggest that early intervention not only is more effective in terms of disease prevention, but also often requires more benign forms of therapy. In contrast, the ability to identify an individual who will truly develop type 1 diabetes (among an at-risk population) increases as the individual approaches onset of overt disease. Although this model does not restrict the ability to provide preventative intervention therapy for individuals at or near onset of disease, the degree of residual β -cell mass must be considered when assigning individuals to various therapeutic protocols. IVGTT = intravenous glucose tolerance test; IAA = insulin autoantibodies; GADA = glutamic acid decarboxylase. (From Atkinson, M.A., *The Lancet*, 358, 230, 2001.)

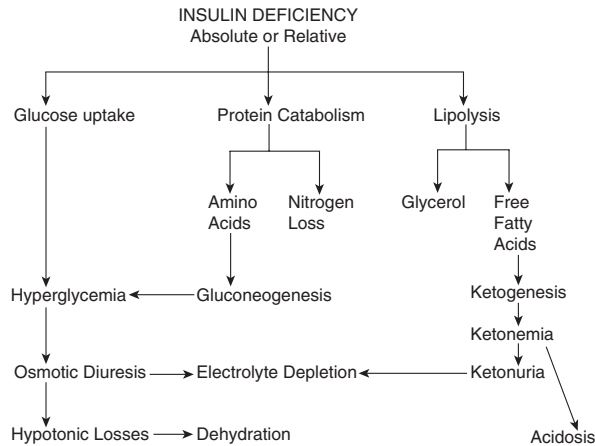

FIGURE 10 Pathogenesis of diabetic ketoacidosis.

exact cause for the destruction of beta cells remains elusive and intensive research is required.

C. Symptoms, Signs, and Complications

Polyuria, polydipsia, weight loss, tiredness, lethargy, fatigue, and infections of the skin and urogenital tract are often bothersome. The most life-threatening complication of diabetes is diabetic ketoacidosis manifested by acceleration of both the abovementioned and the following symptoms:

- Hyperglycemia: Plasma glucose usually greater than 300 mg/dl (17 mmol/L)
- Hyperketonemia: Ketones present in the blood and urine
- Acidosis: pH less than 7.2 and bicarbonate less than 15 mEq (mmol/L)
- Anion gap greater than 16 mEq/L (mmol/L)
- Diabetic ketoacidosis is always caused by insulin deficiency, either absolute, i.e., a previously undiagnosed patient or one who omitted insulin) or relative (i.e., too little insulin injected or antagonism by stress hormones); see Fig. 10

D. Management

I. Emergencies

The initial goal of therapy is to treat life-threatening emergencies which include dehydration and deficiencies in insulin and potassium. The circulating blood volume is low because of dehydration and this must be restored to maintain cerebral, coronary, and renal perfusion. Diabetic

ketosis usually has a precipitating cause that should be identified, corrected, and avoided in the future.

2. Clinical Studies

a. The Diabetes Prevention Trial–Type 1 (DPT–1)

Study question and methods: The comparison of prophylactic insulin therapy was assessed. In this study, 84,000 relatives of affected children were screened for islet cell antibodies. Individuals were selected on the basis of very high risk — a greater than 50% chance of progression to diabetes within five years. Approximately 30% of individuals had IGT on randomized addition. This was an exceptional trial in that families had a choice to accept insulin treatment for relatives who did not have diabetes or to deny children a therapy likely to be beneficial.

Conclusions: Insulin treatment did not delay the onset of type 1 diabetes.

b. Cyclosporine Trial

It is believed that approximately 10% of beta cells are viable on the onset of symptoms of type 1 diabetes, and there is the potential for recovery of some beta cell function. Trials with cyclosporine and immune intervention showed modest benefits, but this dissipated when treatment was discontinued. There is need for newer agents without these adverse effects.

CD3 complexes are located on the surface of lymphocytes in association with the T-cell receptor and they have been shown to play a significant part in the antigen-specific activation of T cells. Anti-CD3 antibodies bind to this complex. They have been tested but appear to be of limited value.

3. Transplantation

Although some “cures” have been accomplished with both pancreas and islet transplantation, limitations of both forms of transplantation are obvious. A worldwide epidemic cannot be treated by transplantation; the relative lack of organ donors for allogeneic transplantation and the need for continuous immunosuppression to block the recurrent autoimmune islet cell destruction renders this treatment modality to only a few fortunate individuals.

E. Perspective

A considerable amount of research has been done, but scientists have not uncovered the exact pathogenesis of type 1 diabetes. Prevention of the disease and its

complications and prolongation of life appear to be unobtainable. If environmental determinants can be defined as playing a definite role in the basis of the disease, then there is hope for a cure. This statement from Atkinson et al. appears appropriate:

Prospective studies of infants developing anti-islet autoantibodies and eventually diabetes could improve and refine our understanding of potential environmental-like triggering factors in infancy, although the DAISY study from the United States and the BABYDIAB study from Germany did not show any adverse effects from early cow's milk exposure, breast-feeding, enteroviral infection, or timing of vaccination.

Nonetheless, the Finnish reports suggested a strong potential for such associations.

BIBLIOGRAPHY

- Abbasi, F., Brown, B. W., Lamendola, C. et al. Relationship between obesity, insulin resistance, and coronary heart disease risk. *J. Am. Coll. Cardiol.*, 40:97–143, 2002.
- Atkinson, M. A., and Eisenbarth, G. S. Type 1 diabetes: New perspectives on disease pathogenesis and treatment. *Lancet*, 358:221–29, 2001.
- Brousseau, M. E., Schafer, E. J., and Wolfe, M. L. Effects of an inhibitor of cholesteryl ester transfer protein on HDL cholesterol. *N. Engl. J. Med.*, 350:1505–1515, 2004.
- Cho, E., Rimm, E. B., Srampfer, M. J. et al. The impact of diabetes mellitus and prior myocardial infarction on mortality from myocardial infarction and from coronary heart disease in men. *J. Am. Coll. Cardiol.*, 40:954–60, 2002.
- Fajans, S. S., Bell, G. I., and Polonsky, K. S. Molecular mechanisms and clinical pathophysiology of maturity onset diabetes of the young. *N. Engl. J. Med.*, 345:971–78, 2001.
- Gale, E. A. M. Can we change the course of beta cell destruction in type 1 diabetes? *N. Engl. J. Med.*, 346:1740–41, 2002.
- Marso, S. P. Optimizing in the diabetic formulary: Beyond aspirin and insulin. *J. Am. Coll. Cardiol.*, 40:652–61, 2002.
- Masoudi, F. A., Inzucchi, S. E., Wang, Y., Havranek, E. P., Foody, J. M., Krumholz, H. M. et al. Thiazolidinediones, Metformin, and outcomes in older patients with diabetes and heart failure: An observational study. *Circulation*, 111:583–590, 2005.
- Moreno, P. R., Fuster, V. et al. New aspects in the pathogenesis of diabetic atherothrombosis. *J. Am. Coll. Cardiol.*, 44:2293–2300, 2004.
- Nesto, R. W., and Libby, P. In *Heart Disease*. E. Braunwald, ed. W. B. Saunders, Philadelphia, 2001, pp. 2133–47.
- Shinozaki, K., Hirayama, A., Nishio, Y. et al. Coronary endothelial dysfunction in the insulin resistance state is linked to abnormal pteridine metabolism and vascular oxidative stress. *J. Am. Coll. Cardiol.*, 38:1821–8, 2001.
- Tuomilehto, J. T., Lindstrom, J., Eriksson, J. G. et al. To prevention of Type II diabetes by changes in lifestyle among subjects with impaired glucose tolerance. *N. Engl. J. Med.*, 344:1343–50, 2001.
- United Kingdom Prospective Diabetes Study Group. Tight blood pressure control and risk of macrovascular and microvascular complications in type 2 diabetes. *BMJ*, 317:703, 1998.
- Van Belle, E., Perie, M., Braune, D. et al. Effects of coronary stenting on vessel patency and long-term clinical outcome after percutaneous coronary revascularization in diabetic patients. *J. Am. Coll. Cardiol.*, 40:410–7, 2002.
- Van Dam, R. M., and Feskens, E. J. M. Coffee consumption and risk of type II diabetes. *Lancet*, 360:1477–80, 2002.
- Weinstein, A. R., Sesso, H. D., Lee, I. M. et al. Relationship of physical activity versus body mass index with type II diabetes in women. *JAMA*, 292:1188–1194, 2004.

Diets and Heart Disease

- I. Diets
- II. Trans Fatty Acids and Coronary Artery Disease
- III. Diet–Drug Valvulopathy
- IV. Fish Oils

GLOSSARY

angina chest pain caused by temporary lack of blood to an area of heart muscle cells, usually caused by severe obstruction of the artery supplying blood to the segment of cells.

coronary artery disease obstruction of the coronary arteries with symptoms such as chest pain, angina, or heart attacks.

myocardial infarction death of an area of heart muscle due to blockage of a coronary artery by blood clot and atheroma; medical term for a heart attack or coronary thrombosis.

CORONARY ARTERY DISEASE (CAD) IS A CAUSE OF serious cardiac events including angina and myocardial infarction which may be fatal or nonfatal. Diets to prevent CAD have been advocated for more than 40 years. Several weight-reduction diets have been fashionable over the past 50 years. The prevalence of obesity (body mass index or BMI > 30) and the population of overweight individuals (BMI > 25) has increased dramatically in North America during the last 20 years (~43% of the United States in 1961 vs. ~55% in 1994). This increase has occurred despite attempts at dietary controls. In this population of patients the risk for diabetes and CAD is increased. Waist circumference of greater than 35 inches in women and greater than 40 inches in men is an easily measured marker of increased CAD risk.

In patients where dyslipidemia is present, as defined by an elevated total cholesterol and low-density lipoprotein (bad) cholesterol, dietary restriction to reduce these elevated levels has shown a definite but modest reduction in risk for CAD; see the chapters Dyslipidemia and Cholesterol.

I. DIETS

A. Controversial Diets

These controversial diets include the Dean Ornish program and the Atkins diet.

The Dean Ornish program advises a low-fat, vegetarian approach coupled with exercise, stress reduction, and smoking cessation. This diet appears to reduce the risk of CAD, but again the reduction is modest and only formally tested by coronary angiograms in a few individuals. There is no randomized trial or large trial that has tested this diet. In addition, cessation of smoking is vitally important, but stress reduction and exercise are additive. Thus, the effect of the Ornish dietary program has not proven its value and is particularly difficult to follow for the long period of time necessary to significantly alter the risk for coronary events.

The Atkins-type diet was tested in a small study conducted in only 45 adults. The 45 adults were randomized and assigned to eat a high-fat, low-carbohydrate diet or a low calorie, high-carbohydrate, low fat [incorrectly called “conventional diet”]. After a short period of only three months, the dangerous plasma LDL cholesterol increased in the low-carbohydrate, high-fat group and decreased slightly in the low-fat group. Thus the Atkins-type diet may substantially increase the risk for atheroma development and progression in individuals who have a propensity to develop cardiovascular disease (see the chapters Obesity and Heart Disease and Atherosclerosis/Atherothrombosis).

B. Recommended Diets

I. The Mediterranean Diet

There is good evidence to support the use of a Mediterranean style diet for the reduction of CAD risk. The background evidence gathered from the Seven Countries Study in the 1960s suggested that the Cretan Mediterranean diet

was associated with the lowest incidence of mortality from CAD as compared to other countries in Europe and in North America. The cohort in Crete consumed less meat and saturated fats and had more fruit, nuts, legumes, fish, and unsaturated fats, with an abundance of olive oil and red wine. Two randomized studies have shown the effectiveness of the Mediterranean diet.

a. The Lyon Diet Heart Study

This is a hallmark study.

Methods: This study randomized 605 survivors of the first myocardial infarction to a Mediterranean type diet or a “prudent Western type diet.”

Results: After a median follow up of 46 months, the risk of fatal or nonfatal myocardial infarction was 65% lower for those on the Mediterranean diet.

Mediterranean diet contents: High intake of bread, food, and margarine (canola oil base with added alpha-linolenic acid), and canola and olive oil that has a high monounsaturated fat, oleic acid content. In the above study the total amount of oil consumed was similar for both groups, but canola and olive oil was used in the treated group and sunflower oil in the prudent diet group. The treated group intake consisted of 30% total fat, 8% saturated fat, 203 mg cholesterol daily, versus 34%, 12%, and 312 mg cholesterol, respectively, for the prudent diet. Alpha-linolenic and oleic acid intake was higher, and linoleic acid intake was lower in the treated group.

The mean serum cholesterol levels at the end of follow up were 6.18 mmol/L in the control group and was similar, 6.20 mmol/L, in the treated group. Lipid-lowering medications were used in 34 and 26.5%, respectively. Apart from the beneficial effect of alpha-linolenic and oleic acid, there may have been benefits in the experimental group caused by higher consumption of antioxidants such as polyphenols that are present in fruits, vegetables, and red wine.

b. Clinical Study by Singh et al., the Indo-Mediterranean Diet

Methods: There were 1000 patients in India, approximately 59% with proven CAD (angina pectoris and myocardial infarction), randomized to a diet rich in whole grains, fruits, vegetables, walnuts, and almonds. The control group consumed a local diet similar to the step 1 National Cholesterol Education Program prudent diet which includes a diet of fat intake reduced to 30% of food energy with approximately 15% from saturated fats and 10% from polyunsaturated fats. It also included <300 mg

of cholesterol, 55% carbohydrates, 55% protein, and 15% of calories daily.

In both groups approximately 66% of patients were vegetarian. All individuals in the study consumed milk, butter, clarified butter (Indian ghee), and trans fatty acids (vegetable ghee made from partly hydrogenated oils). Vegetarian individuals consumed more milk, vegetable ghee, peanut oil, and clarified butter than the nonvegetarians. Nonvegetarian individuals, 33% of the group, ate two portions of meat and 2–5 eggs per week.

The treated group was advised to have an intake of 250–300 g of fruit, 125–150 g of vegetables, 25–50 g of walnuts and almonds, 400–500 g of whole grains, legumes, rice, maize, and wheat, and 3–4 servings of mustard seed or soybean oil daily. The mean intake of alpha-linolenic acid was twofold greater in the intervention group. Approximately 73% of the patients had mild hypercholesterolemia, 21% had diabetes, 36% had hypertension, and about 50% were smokers.

Results: Total cardiac events were significantly fewer in the treated group than in the controls: 39 versus 76 events ($P < 0.001$), nonfatal heart attacks 21 versus 43 ($P < 0.001$), and sudden deaths 6 versus 16 ($P = 0.015$).

Perspective: An Indo-Mediterranean diet that is rich in alpha-linolenic acid appears to be more effective in primary and secondary prevention of CAD in Asians than the so-called healthy-heart prudent diet. It is of interest that the author of this book obtained supplies of alpha-linolenic acid from Parke-Davis in 1966 and started a small clinical trial in patients following a heart attack. The work was based on the theory that linolenic acid inhibits platelet aggregation, an action now known to initiate the beneficial effects of aspirin and platelet IIa/IIIb receptor blockers now used for the prevention of CAD events.

II. TRANS FATTY ACIDS AND CORONARY ARTERY DISEASE

There is no doubt that trans fatty acids contribute significantly to the risk of CAD. On a per gram basis, the effect on coronary risk of trans fatty acids is stronger than that of the well-known effects of saturated fatty acids.

Trans fatty acids are so-called because the carbon atoms adjacent to their double bonds are on opposite sides resulting in a straight configuration and a solid substance at room temperature. On the other hand, unsaturated fatty acids contain double bonds as cis isomers, and here the adjacent carbon atoms are on the same side of the double bond. This results in a bent shape and a liquid substance

at room temperature. The process used to produce trans fatty acids and solid fats is called partial hydrogenation. In addition, partial hydrogenation is frequently used commercially because it removes the beneficial linolenic acid that may cause the fat to become rancid when exposed to high temperatures used for commercial deep fat frying and when stored. Trans fat usage increased over the past two decades because of the concern over the use of palm and coconut oils that were used extensively in processed foods. These two oils contain a high amount of saturated fat.

A. Clinical Study: Oomen et al.

Study question: A Dutch population with a fairly high trans fatty acid intake including trans fatty acids from partly hydrogenated fish oils was investigated. The relation between trans fatty acid intake and CAD were studied.

B. Zutphen Elderly Study

Methods: This investigation prospectively studied 667 men aged 64–84 years and free of CAD. The dietary survey was used to establish the participants food-consumption patterns. Information risk factors were obtained in 1985, 1990, and 1995.

Results: From 1985 to 1995 trans fatty acid intake decreased from 4.3 to 1.9% of energy. Trans fatty acid

intake at baseline was positively associated with a 10-year risk of CAD after adjustment for age, BMI, smoking, and dietary covariates.

Perspective: From 1996 there has been a continuing decrease in trans fatty acid intake in The Netherlands and in other European countries, where there has been a fall in trans fatty acid content of margarines, but no increase in its use in commercially baked products and fast foods. In the United States, however, there has been a fall in trans fatty acid content of margarines but an increase in trans fatty acid consumption from commercially baked products and fast foods. The decrease in trans fatty acid intake of 2.4% of energy reported in this study could have contributed to about 22% less deaths from CAD, approximately 4600 of 20,000 coronary deaths in The Netherlands annually.

C. Effect on Blood Lipids

Both trans fatty acids and saturated fats increase LDL cholesterol levels to a similar degree, but trans fatty acids lower HDL (good) cholesterol levels. Intake of saturated fatty acids does not decrease HDL cholesterol levels. The ratio of LDL to HDL cholesterol has been shown to be significantly higher with the intake of trans fatty acids than with consumption of saturated fats. The net effect of trans fatty acids on the LDL to HDL cholesterol ratio is approximately double that of saturated fatty acids. Thus, trans fatty acid intake is expected to significantly increase the risk of coronary artery events. Figure 1 indicates that an

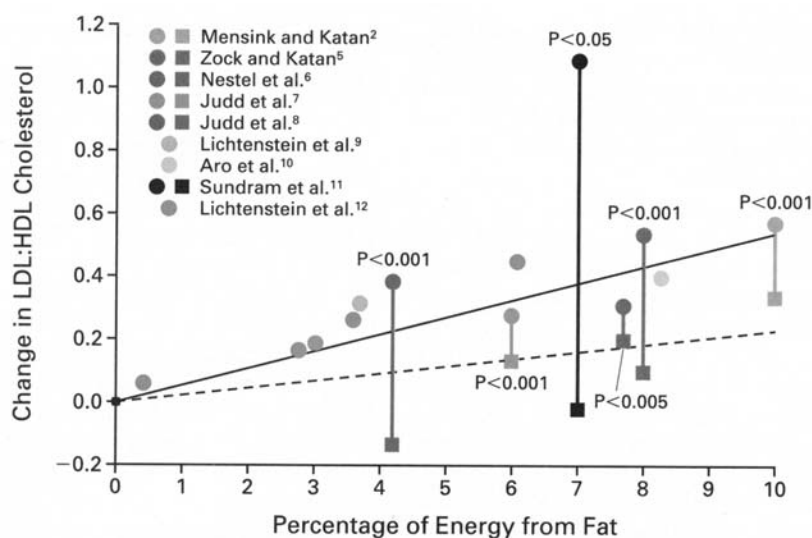

FIGURE 1 Results of randomized studies of the effects of a diet high in trans fatty acids (circles) or saturated fatty acids (squares) on the ratio of LDL cholesterol to HDL cholesterol. A diet with isocaloric amounts of cis fatty acids was used as the comparison group. The solid line indicates the best-fit regression for trans fatty acids. The dashed line indicates the best-fit regression for saturated fatty acids. (From Ascherio, A., Katan, M.B., Zock, P.L., et al., Trans fatty acids and coronary heart disease, *N. Engl. J. Med.*, 340, 1994–1997, 1999. With permission.)

absolute increase in 2% intake of trans fatty acid is expected to raise the ratio of LDL to HDL cholesterol by 0.1 unit; a 1-unit increase in this ratio is associated with a 53% increase in the risk of CAD. The intake of 2% of calories from trans fatty acids would be predicted to cause a substantial number of cardiac deaths in United States. Canadians are among the world's biggest consumers of trans fat, consuming an average of 10 g daily.

Trans fatty acids also increase Lp(a)-protein levels that have been associated with an increased risk of CAD. In addition, these acids raise triglyceride levels, so that the entire spectrum of lipid levels in the blood is high enough to be considered a significant dyslipidemia (see the chapter Dyslipidemia).

D. Foods Containing Trans Fatty Acids

Trans fatty acids are present in:

1. Solid fats produced by part hydrogenation of oils.
2. Natural products originating from ruminant, cud-chewing animals. Importantly, milk contains virtually no trans fat.
3. Commercially baked products and fast foods, for example, a large order of french fries contains 3.68 g of trans fatty acids and one doughnut contains 3.2 g (see Table 1).

A change in eating habits is necessary, particularly, in North America. Unfortunately manufacturers who produce

foods high in trans fatty acids are not requested to include the content in food labels. Even foods labeled cholesterol-free and cooked in vegetable oil may have a high content of trans fatty acids. Both stringent labeling and public education should be required.

III. DIET-DRUG VALVULOPATHY

A. Anorectic Agents

Obesity is a risk factor for CAD, diabetes, and hypertension. Weight-reduction diets assist less than 25% of obese individuals; a return of weight gain is common, often within months of ending the diet that is difficult to adhere to for several years. For the past 50 years drugs have been sought to decrease appetite and food intake that results in significant weight loss. Most anorectic agents disappear from the market after 1–5 years because of adverse effects and adverse publicity. The drug phentermine (phen-fen) was approved in United States in 1959. This noradrenergic agent was soon lost. Fenfluramine, a sympathomimetic amine that activates the serotonergic pathways in the brain to induce its anorectic effects, and fenfluramine, the D-isomer of fenfluramine, were approved in 1973 and 1996, respectively. The combination of fenfluramine and phentermine appeared more efficacious than monotherapy, and it was widely prescribed from 1995 to 1998 to about 4.6 million individuals in the United States.

TABLE I

Trans Fatty Acid Content of Some Popular Processed Foods Prepared in Restaurants and Fast Food Outlets (any serving containing >0.5 g is considered excessive)

Product	Serving size	Trans fatty acid (~g/serving)
Buttered popcorn	4 cups	5
Chicken fingers	One chicken finger	8
Chicken wings	10 wings	10
Cinnamon roll	One roll	4
Bran muffin	One muffin	0.5
Fried clams	One clam	10
Fried onion rings	One serving with dipping sauce	18
French fries	One	5
Frozen fish (batter)	One serving	2.5
Hash browns	One order	8
Large hamburger	One	4
Waffles	Two	2

I. Reasons for Withdrawal from the Market

Reports in 1997 indicated that a few patients taking the daily combination of fenfluramine and phentermine for several months developed pulmonary hypertension and valvular defects such as aortic and mitral regurgitation. These valves were noted to be diffusely thickened and incompetent (regurgitant or leaky valves). Also, the histologic findings appeared to be identical to valvular damage observed in carcinoid syndrome where serotonin is responsible for the valve damage. In carcinoid syndrome the valve lesions are usually on the right side of the heart, however, the lesions from the diet drugs included the aortic and mitral valves which are on the left side of the heart (see the chapter Carcinoid Heart Disease).

Although only 24 patients were reported in 1997 by one group, a survey of five sites using echocardiographic evaluation found significant valve regurgitation in approximately 1% of patients treated with a combination. These drugs were withdrawn from the market in 1997.

Further studies indicated an incidence of this type of valvulopathy occurred in 7.1 of 10,000 patients treated for less than 4 months and 35 of 10,000 patients treated for greater than 4 months. In one study of 1163 individuals treated with a combination a mild grade of aortic regurgitation was present in 8.8% of treated versus 2.6 of control patients ($p < 0.01$). Lesions of the valves were worse in patients taking the combination for more than 6 months. It appears, therefore, that there was about a 5.2% increase in prevalence of significant aortic regurgitation in the drug-treated patients.

Nearly all patients with valvular lesions who discontinued the drugs had no progression of lesions and some even showed signs of regression. Only one of the original patients described required valve surgery.

B. Perspective and Research Implications

The problems that afflict overweight individuals will not disappear. In fact the prevalence of obesity is increasing and becoming an insurmountable problem in North America. There must be a continued search for anorectic drugs that are as important for millions of individuals as the elixir of life. Researchers should be able to find suitable agents that are devoid of cardiac or cardiovascular side effects. It is obvious that agents that involve the serotonin pathway would be expected to cause cardiac lesions. This is a fruitful area of research that can help millions of individuals worldwide.

IV. FISH OILS

The low mortality from coronary heart disease in Greenland Inuit is attributed to their intake of more than 350 g per day of whale and seal meat. In Japan, the incidence of coronary heart disease is much lower in areas where fish consumption is high, but the alpha-linolenic acid in soybeans and other products may be responsible for their low mortality from heart disease.

Fatty fish contains omega n-3 fatty acids represented mainly by eicosapentaenoic and docosahexaenoic acids. These agents have an aspirin-like effect that prevents blood platelets from clumping together; this action prevents clot formation. They also have other beneficial effects on the walls of the arteries.

Nonetheless, studies of large populations in Norway and Japanese men in the Honolulu Heart Program showed no beneficial effect of fish intake on cardiovascular disease. In contrast, however, a study in 872 men followed from 1960–1980 showed a 40% reduction in the risk of death

from coronary heart disease in those who ate an average of 70 g of fish a week compared with those who did not eat fish. The Western Electric Study of 1931 men followed for 25 years showed some reduction in coronary heart disease mortality in men eating approximately 60 g of fish per week compared with those who ate no fish. These nonrandomized studies have many limitations, however, and may not answer questions adequately.

In a small, randomized trial of diet in 2033 men who had had a previous heart attack, it was found that consuming two servings of 200–400 g of fatty fish per week for two years caused a significant reduction in mortality and nonfatal heart attacks. Because this clinical trial and other surveys show a positive trend for protection from heart attacks, investigators concluded that it is advisable for individuals over age 25 to eat two servings of 175 g (6 oz) of fatty fish weekly. Individuals with a family history of heart attacks before age 60 and those who have had a heart attack should use this simple nondrug protective regimen. Fatty fish include salmon, tuna, mackerel, cod, and herring. Any beneficial effect is obtained with one or two servings of fish per week and more is not better.

BIBLIOGRAPHY

- Appeldoorn, C. C. M., Bonnefoy, A., Lutters, B. C. H., Daenens, K., van Berkel, T. J. C., Hoylaerts, M. F., Biessen, E. A. L. et al. Gallic acid antagonizes P-selectin – mediated platelet – leukocyte interactions: Implications for the French paradox. *Circulation*, 111:106–112, 2005.
- Ascherio, A., Katan, M., Zock, P. L. et al. Trans fatty acids and coronary heart disease. *N. Engl. J. Med.*, 340:1994–98, 1999.
- Ascherio, A., Rimm, E. N. B., Stampfer, M. J. et al. Dietary intake of marine n-3 fatty acids, fish intake, and the risk of coronary disease among men. *N. Engl. J. Med.*, 332:977, 1995.
- Dallongeville, J., Yarnell, J., Ducimetiere, P. et al. Fish consumption is associated with lower heart rates. *Circulation*, 108:820–825, 2003.
- Dansinger, M. L., Gleason, J. A., Griffith, J. L. et al. Comparison of the Atkins, Ornish, Weight Watchers, and Zone Diets for weight loss and heart disease risk reduction: A randomized trial. *JAMA*, 293:43–53, 2005.
- de Lorgeril, M., Renaud, S., Mamelle, N. et al. Mediterranean alpha-linolenic acid-rich diet in secondary prevention of coronary heart disease. *Lancet*, 343:1454, 1994.
- Eckel, R. H., York, D. A., Rössner, S. et al. Prevention conference VII: Obesity, a worldwide epidemic related to heart disease and stroke: Executive summary. *Circulation*, 110:2968–2975, 2004.
- Foster, G. D., Wyatt, H. R., Hill, J. O. et al. A randomized trial of a low carbohydrate diet for obesity. *N. Engl. J. Med.*, 348:2082–90, 2003.
- Katz, D. L., Evans, M. A., Nawaz, H., Njike, V. Y., Chan, W., Comerford, B. P., Hoxley, M. L. et al. Egg consumption and endothelial function: a randomized controlled crossover trial. *Int. J. Car.*, 99:65–70, 2005.
- Klein, S., Burke, L. E., Bray, G. A. et al. Clinical implications of obesity with specific focus on cardiovascular disease: A statement for professionals from the American Heart Association Council on

- nutrition, physical activity, and metabolism: Endorsed by the American College of Cardiology Foundation. *Circulation*, 110:2952–296, 2004.
- Knoops, K. T. B., de Groot, L. C. P. G. M., Kromhout, D. et al. Mediterranean diet, lifestyle factors, and 10-year mortality in elderly European men and women: The HALE Project. *JAMA*, 292:1433–1439, 2004.
- Mann, J. I. Diet and risk of coronary heart disease and type II diabetes. *Lancet*, 360:73–88, 2002.
- Mozaffarian, D., Ascherio, A., Hu, F. B., Stampfer, M. J., Willett, W. C., Siscovick, D. S., Rimm, E. B. et al. Interplay between different polyunsaturated fatty acids and risk of coronary heart disease in men. *Circulation*, 111:157–164, 2005.
- Mullis, R. M., Blair, S. N., Aronne, L. J. et al. Prevention conference VII: Obesity, a worldwide epidemic related to heart disease and stroke: Group IV: Prevention/Treatment. *Circulation*, 110:e484–e488, 2004.
- Murthy, T. H., and Weissman, N. J. Diet-Drug Valvulopathy. *ACC Curr. J. Rev.* Mar/Apr, 17–20, 2002.
- Oomen, C. M., Ocke, M. C., Fesken, E. J. M. et al. Association between trans fatty acid intake and 10-year risk of coronary heart disease in the Zutphen Elderly Study: A prospective population based study. *Lancet*, 357:746–51, 2001.
- Samaha, F. F., Iqbal, N., Seshadri, P. et al. A low carbohydrate as compared with a low fat diet in severe obesity. *N. Engl. J. Med.*, 348:2074–81, 2003.
- Singh, R. B., Dubnov, G., Niaz, M. A. et al. Effects of an endo Mediterranean diet on the question of coronary artery disease in high-risk patients (endo Mediterranean diet heart study): A randomized double-blind trial. *Lancet*, 360:1455–1461, 2002.
- Szmitko, P. E., Verma, S. et al. Red wine and your heart. *Circulation*, 111:e10–e11, 2005.
- Trichopoulos, A., Cistacou, T., Barmia, C. et al. Adherence to a Mediterranean diet and survival in a Greek population. *N. Engl. J. Med.*, 348:2599–608, 2003.
- Zitron, E., Scholz, E., Owen, R. W., Lück, S., Kiesecker, C., Thomas, D., Kathöfer, S., Niroomand, F., Kiehn, J., Kreye, V. A.W., Katus, H. A., Schoels, W., Karle, C. A. et al. QTc prolongation by grapefruit juice and its potential pharmacological basis: HERG channel blockade by flavonoids. *Circulation*, 111:835–838, 2005.

Diuretics

- I. Indications
- II. Renal Physiology
- III. Individual Diuretics

GLOSSARY

- arrhythmia** general term for an irregularity or rapidity of the heartbeat, an abnormal heart rhythm.
- electrolytes** sodium, potassium, calcium, and magnesium levels in the blood.
- heart failure** failure of the heart to pump sufficient blood from the chambers into the aorta; inadequate supply of blood reaches organs and tissues.
- gynecomastia** enlargement of the breast, usually seen in men.
- hypertension** high blood pressure.

I. INDICATIONS

A. Hypertension

Diuretics, so-called water pills, are the most valuable, yet inexpensive agents of proven benefit for the management of hypertension. These agents have been used worldwide for more than 40 years and are still considered by experts to be the first choice for the initial treatment of hypertension. The World Health Organization (WHO) and the Joint National Committee (JNC) advise that a diuretic or a beta-blocker should be chosen as initial therapy for most patients, except those with bronchial asthma in whom a beta-blocker is contraindicated.

A diuretic is the drug of choice for the initial treatment in individuals of African origin over age 60, because these agents have been shown to be more effective than the three other agents available for the management of hypertension. Diuretics are not as effective in the younger individuals of African origin. A diuretic is necessary for the management of hypertension in patients with heart failure or edema

and in patients who have not responded adequately to one of the three antihypertensive agents, beta-blockers, ACE inhibitors, or calcium antagonists.

B. Heart Failure

Diuretics, particularly loop diuretics such as furosemide and torsemide, are the mainstay of therapy for the millions of patients with moderate-to-severe heart failure. Severe shortness of breath due to congestion of blood with retention of salt and water in the lungs is relieved by diuretics. There is little or no benefit from the three major drugs used for the optimal therapy of heart failure.

Patients with severe heart failure graded as New York Heart Association class IV, and those with pulmonary edema that causes life-threatening and distressing shortness of breath with the patient at rest, attain immediate and sometimes temporary relief from these distressing symptoms with the administration of intravenous loop diuretics. In states of severe heart failure (class IV), beta-blocking drugs that are very beneficial in the management of class I–III heart failure are contraindicated and ACE inhibitors do not provide symptomatic relief.

C. Edema Caused by Kidney or Liver Disease

Some forms of kidney disease caused by nephrotic syndrome diseases such as glomerulonephritis and diabetic nephropathy may cause considerable salt and water retention and both legs may become swollen with pitting edema. This can be observed with finger pressure applied to the legs. Fluid retention may be excessive and involve the abdominal cavity (ascites). Similar accumulation of fluid in the lower limbs and cavities of the body may occur in patients with cirrhosis.

A combination of loop diuretics such as furosemide combined with an aldosterone antagonist is usually necessary to elicit relief. An aldosterone antagonist is necessary as outlined in Section III.C.

II. RENAL PHYSIOLOGY

Figure 1 is a diagrammatic representation of the nephron. It is important for readers to have some knowledge of the fluid and electrolyte balance of the body which is maintained in a constant state by the automatic electronic filtration system provided by the kidney. Each human kidney contains approximately one million nephrons. Each nephron is a mini filter that includes a glomerulus that contains a group of capillary blood vessels. The primary duty of the glomerulus is excretion of water and solutes. A considerable amount of sodium and water passes from the glomerulus into the renal tubule and then a substantial amount of sodium and water and other electrolytes must

be reabsorbed into the circulation in correct proportions to maintain the constancy of the body fluids. The primary duty of the renal tubules are the retention and conservation of water and essential electrolytes such as sodium and potassium. The tubules have a secretory function that removes a vast quantity of water from the tubules and returns the fluid, sodium, potassium, and other electrolytes in correct proportions to the circulating blood. This normal physiologic activity is inhibited by diuretics.

The nephrons filter more than 180 liters daily (125 ml per minute). This volume of water passes into the tubules and approximately 179 liters are reabsorbed daily with only about 1–2 liters eliminated as urine. Without the intervention of the tubules between the glomeruli and the

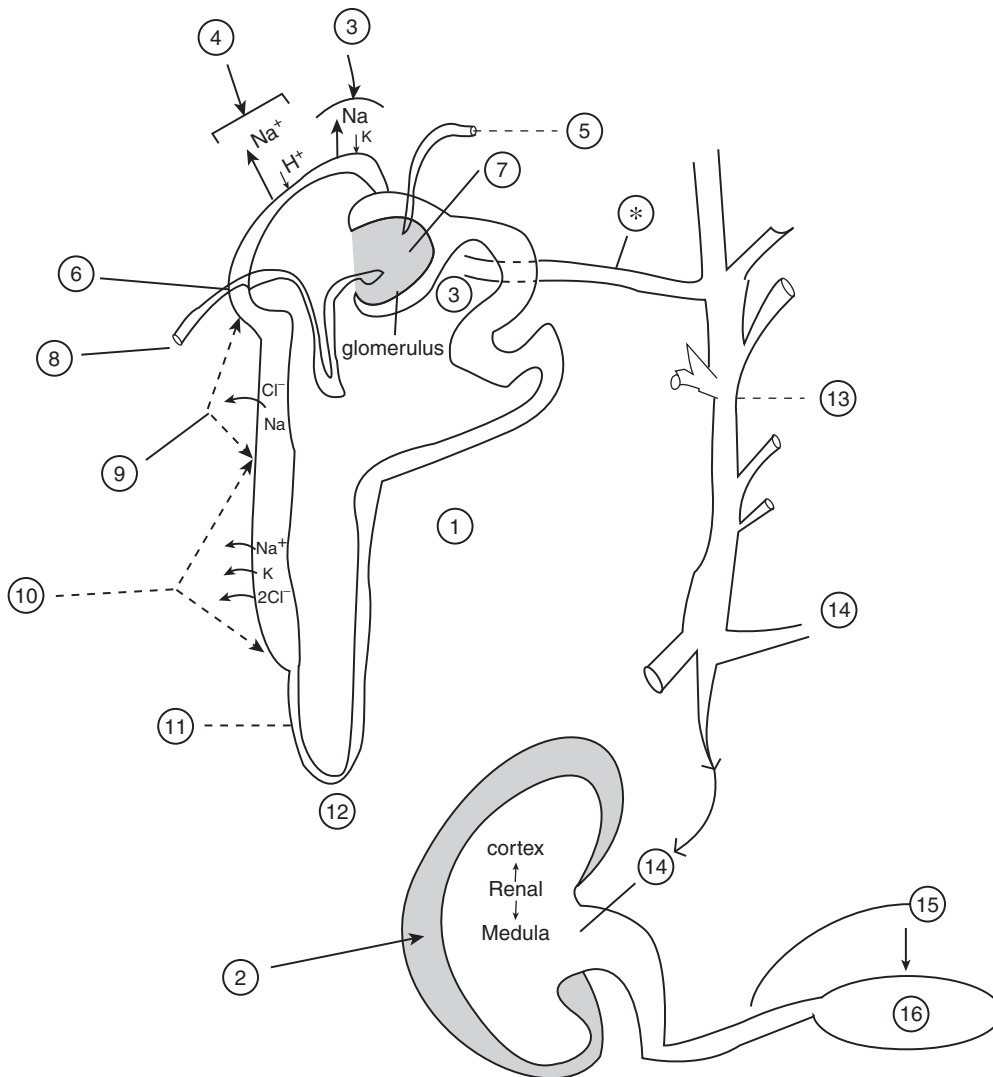

FIGURE 1 The nephron and the site of action of diuretics. 1 = single nephron; 2 = the kidney – 1 million nephrons; 3 = distal tubule site of action of aldosterone – spironolactone and eplerenone; 4 = amiloride and triamterene; 5 = efferent arteriole; 6 = macula densa; 7 = glomerular capillaries; 8 = afferent arteriole; 9 = thiazides; 10 = loop diuretics; distal tubule 11 = ascending limb; 12 = loop of Henle; 13 = collecting tubule; 14 = to renal pelvis; 15 = to ureter; 16 = bladder; * = distal tubule: H₂O reabsorption under control of vasopressin.

renal pelvis, which joins the ureter and the bladder, the whole water and soluble constituents of the body would be lost in less than 24 h. This situation occurs in conditions that cause obstruction of the tubules or renal tubular necrosis.

III. INDIVIDUAL DIURETICS

The generic and trade names of available diuretics are given in Table 1.

A. Thiazides

I. Mechanism of Action

Figure 1 shows a glomerulus and the four main sites of the renal tubules at which diuretics inhibit the reabsorption of sodium and chloride. As the distal convoluted tubule of the nephron approaches the vicinity of the glomerulus, it comes in close proximity to the vascular pole of the structure. At this site for a short distance the afferent arteriole and distal convoluted tubule maintain contact (see sites 8 and 6 in Fig. 1). In this region the cells of the tubule

TABLE I
Generic and Trade Names of Diuretics

Generic name	Trade name	Tablets (mg)	Usual maintenance (mg daily)
Group I: Thiazides			
Chlorothiazide	Diuril, Saluric	250, 500	500–1000
Hydrochlorothiazide	HydroDiuril, Hydrosaluric, Esidrix, Esidrex, Oretic, Direma Aprinox,	25, 50, 100	12.5–25
Bendrofluazide	Aprinox, Berkozide, Centyl, Neo-NaClex	2.5, 5	2.5–5
Bendroflumethiazide	Naturetin	2.5, 5, 10	2.5–10
Benzthiazide	Aquatag, Exna, Hydrex	50	50–100
Cyclothiazide	Ahydron	2	2
Hydroflumethiazide	Diucardin, Hydrenox, Saluron	50	50
Chlorthalidone	Hygroton	25, 50, 100	25–50
Methyloclothiazide	Enduron, Aquatensen, Diutensen-R	2.5, 5	2.5–5
Polythiazide	Renese, Nephрил	1, 2, 4	0.5–4
Trichlormethiazide	Naqua, Metahydrin	2, 4	2–4
Cyclopenthiiazide	Navidrex, Navidrix	0.5	0.5–1
Metolazone	Zaroxolyn, Metenix	2.5, 5, 10	2.5–5
Quinethazone	Aquamox, Hydromox	50	50–100
Indapamide	Lozol, Natrilix, Lozide (C)	2.5	2.5
Group II: Loop diuretics			
Furosemide,	Lasix, Dryptal,	20, 40, 80, 500	40–120
Frusamide (UK)	Frusetic, Frusid		
Ethacrynic acid	Edecrin	25, 50	50–150
Bumetanide	Burinex, Bumex	0.5, 1, 5	1–2
Piretanide	Arlix	6 (capsule)	6–12
Torseamide	Demadex	5, 10, 20, 100	5–20
Group III: K⁺-sparing diuretics			
Eplerenone	Inspira	25	25–50
Spironolactone	Aldactone	25, 50 (UK), 100	25–100
Triamterene	Dyrenium, Dytac	50, 100	50–100
Amiloride	Midamor	5	5–10
Group IV			
Thiazide + K ⁺ -sparing	Aldactazide, Dyazide, Moduretic, Moduret		
Furosemide + K ⁺ -sparing	Frumil, Frusene Lasoride		
Group V			
Acetazolamide	Diamox	250	—

are more closely aggregated together than in other regions and form a specialized structure, the macula densa. Here the wall of the afferent arteriole is thickened and the cells contain special granules that secrete renin. This region is called the juxtaglomerular complex.

The macula densa appears to function as a peripheral receptor in a feedback mechanism that influences both renin production in cells which are sensitive to sodium ion concentration. These specialized cells respond to a local decrease in blood pressure to stimulate the release of renin. The rate of release of renin is inversely related to the amount of sodium passing into the tubules and its rate of transport into the tubular cells; thus, a decrease in blood pressure or decrease in sodium excretion caused by salt depletion increases renin secretion. Renin release is also increased by activity of renal sympathetic nerves and mediated by beta-adrenergic receptors. Catecholamines released from the adrenal glands stimulates renin release. Renin release is inhibited mainly by high levels of aldosterone and angiotensin. The electronic capacity of the kidney and its unique ability to maintain a constant sodium and potassium level in the circulating blood is a marvelous work of wonder.

Thiazide diuretics inhibit the reabsorption of sodium chloride in the early part of the distal tubule beyond the ascending limb of the loop of Henle; this site is distal to the active tubular site of loop diuretic action (Fig. 1). The loop diuretics have no action at the site at which thiazides inhibit sodium reabsorption. Thiazides also increase the active excretion of potassium in the distal renal tubule, and this may cause hypokalemia. The thiazides have a long duration of action, approximately 12–24 h versus loop diuretics with a duration of 2–6 h. These diuretics, even at large doses, lose their beneficial effects in patients who have renal failure with a serum creatinine greater than 2 mg/dl (180 μ mol/L); fortunately loop diuretics are potent and retain their ability to block sodium reabsorption in patients with severe renal failure.

2. Indications

Thiazide diuretics are indicated mainly for the management of hypertension. Their exact antihypertensive mechanism of action is unknown, but it is believed to be related to a decrease in vascular volume, negative sodium balance, and arteriolar dilation that occurs on a chronic basis which causes a decrease in total peripheral resistance. A decrease in total peripheral vascular resistance causes a fall in blood pressure. Thiazides are not used in the management of heart failure, but they are often combined with a potassium-sparing diuretic to prevent potassium loss.

3. Adverse Effects

Contraindications include hypersensitivity to thiazides or sulfonamides, acute and severe renal failure, pregnancy and breast-feeding, or concomitant use of lithium. Other contraindications include dehydration and electrolyte imbalance with hypokalemia and hyponatremia. Patients with an increase in uric acid with the precipitation of painful joints and gout should not be administered thiazides. Latent diabetes may be increased. Cardiac arrhythmias may occur because of the possibility of serum potassium and magnesium imbalance.

B. Loop Diuretics — Furosemide

Furosemide is a well-known loop diuretic used worldwide since the 1960s. Other loop diuretics such as bumetanide and torsemide have similar actions, indications, and adverse effects.

1. Mechanism of Action

Loop diuretics inhibit the sodium/potassium/chloride transport system of the luminal membrane in the thick ascending limb of the loop of Henle (Fig. 1); thus they block chloride reabsorption at the site where approximately 40% of filtered sodium is normally reabsorbed. Loop diuretics also inhibit calcium, potassium, and magnesium reabsorption in the loop where approximately 25% of filtered potassium, 25% of calcium, and 65% of magnesium are normally reabsorbed.

2. Indications

Intravenous furosemide at doses of 40–120 mg dramatically improves severe shortness of breath caused by pulmonary edema in which there is congestion of the lungs where blood and fluid accumulates in the normally dry air sacs. Pulmonary edema is caused by left ventricular failure. There are several million individuals in North America with heart failure who must take between 40 to 80 mg of furosemide to prevent bothersome shortness of breath and fluid accumulation in the lungs and legs.

Loop diuretics are indicated to remove extra fluid from the body in patients with renal failure as thiazide diuretics become ineffective in with these patients.

3. Adverse Effects

These are similar to the adverse effects described for thiazides, but severe hypokalemia commonly occurs when

high doses of furosemide must be used. The interactions may occur with a concomitant use of cephalosporin or aminoglycoside antibiotics such as gentamicin. The decreased sodium reabsorption in the proximal tubules causes increased reabsorption of lithium which may contribute to lithium toxicity.

C. Aldosterone Antagonists/Potassium-Sparing Diuretics

These agents include spironolactone, eplerenone, amiloride, and triamterene. These weak diuretics are often used in combination with thiazides strengthening their role in the management of hypertension and assuming a new role in the management of heart failure. They appear to decrease the incidence of serious ventricular arrhythmias in patients with heart failure and hypertension. Spironolactone has a positive inotropic effect that is independent and additive to that of digoxin, and the drug increases stroke volume.

I. Spironolactone

a. Mechanism of Action

Increased renin release from the juxtaglomerular cells is caused by several conditions: reduction in renal blood flow from heart failure, blood loss, hypotension or ischemia of the kidneys, sodium diuresis (excessive sodium loss in urine), and beta-adrenergic stimulation. Renin converts liver angiotensinogen to angiotensin I. Angiotensin II stimulates adrenal aldosterone production. An increase in aldosterone secretion occurs mainly in heart failure. Aldosterone causes reabsorption of sodium and water in the tubules distal to the region of the macula densa, which appear to sense and monitor sodium concentration at that point in the tubules. Aldosterone antagonists or inhibitors retain potassium in exchange for elimination of sodium. Because most of the sodium and water reabsorption occurs in the proximal tubule and in the loop of Henle, the exchange of sodium and potassium that occurs beyond the macula densa is very small but crucial to the maintenance of normal levels of sodium and potassium in the blood.

Spironolactone 25 mg added to ACE inhibitors in patients with heart failure causes a more complete block of the aldosterone production than is achieved solely with ACE inhibition. A randomized clinical trial (RALES) has been shown to decrease mortality and morbidity in patients with heart failure. The beneficial effects are related not only to sodium loss but also to a decrease in cardiac fibrosis and increased production of the dilator

nitric oxide. It appears that aldosterone has deleterious fibrinogen properties and spironolactone may adverse some of these.

Another side effect is gynecomastia, which is sometimes bothersome. An analog of spironolactone, eplerenone, has been shown in a recent large randomized clinical trial in patients with acute myocardial infarction complicated by heart failure or left ventricular dysfunction to significantly reduce mortality and morbidity (see discussion below and in the chapter Heart Failure).

2. Amiloride and Triamterene

These agents inhibit the sodium proton exchanger, which causes sodium reabsorption in the distal tubules. They act with lumen membrane transporters to prevent urinary sodium entry into the cytoplasm. They are direct inhibitors of potassium secretion; thus, potassium loss is indirectly decreased. The loss of sodium is achieved without a loss of magnesium. These agents act beyond the activity of aldosterone and are strictly not direct aldosterone antagonists. Triamterene and amiloride are weak diuretics and are most often used in combination with a thiazide to enhance the effectiveness of thiazides and also to prevent hypokalemia.

a. Adverse Effects

The most common side effect is a marked and dangerous elevation of serum potassium (hyperkalemia) with a serum potassium of 5.5 or greater than 6.0 mEq/L. This occurs in patients with renal failure, a condition in which the kidney fails to excrete potassium. It also occurs in patients on ACE inhibitors that retain potassium and salt substitutes, which contain potassium in place of sodium. These agents should not be used in patients with mild renal failure and in patients with a serum creatinine greater than 1.3 mg/dl (115 $\mu\text{mol/L}$), which may indicate the presence of renal dysfunction. Some patients with type 2 diabetes may have hyporeninemic hypoaldosteronism and hyperkalemia may ensue with these agents.

Megaloblastic anemia has been rarely seen with triamterene and with amiloride and it has been associated with the occurrence of aplastic anemia, albeit rarely. Spironolactone does not have these serious adverse effects but causes bothersome gynecomastia.

3. Eplerenone

This selective aldosterone blocker has been shown to provide the same clinical benefits as spironolactone, but

with a mild decrease in the incidence of two main adverse effects: gynecomastia and hyperkalemia. In the eplerenone post myocardial infarction and heart failure efficacy and survival study (EPHESUS), 6632 patients who were 3–14 days post acute myocardial infarction with an ejection fraction of less than 40% with heart failure and diabetes were randomized. Patients with a serum creatinine greater than 2.5 mg/dl (220 μ mol/L) or serum potassium greater than 5 mmol/L were excluded. At one-year follow up eplerenone-treated patients had an all-cause mortality of 14.45% versus 16.7% for spironolactone-treated patients (one life saved for every 100 patients treated). But eplerenone-treated patients had slightly and significantly higher rates of worsening renal function (creatinine increased 0.06 mg/dl vs. 0.02 mg/dl) and of serious hyperkalemia (5.5% vs. 3.9%). Because eplerenone was not shown to be significantly more effective than spironolactone, the drug may not replace the well-known spironolactone, except in men who show early signs of gynecomastia. Eplerenone has been shown to be as effective as losartan in reducing blood

pressure in patients with high plasma renin activity and more effective than losartan in patients with low plasma renin activity.

BIBLIOGRAPHY

- Bloomfield, D. M., Steinman, R. C., Namerow, P. B. et al. Microvolt T-wave alternans distinguishes between patients likely and patients not likely to benefit from implanted cardiac defibrillator therapy: A solution to the Multicenter Automatic Defibrillator Implantation Trial (MADIT) II Conundrum. *Circulation*, 110:1885–1889, 2004.
- Flack, J. M., Oparil, S., Pratt, H. et al. Efficacy and tolerability of eplerenone and losartan in hypertensive black and white patients. *J. Am. Coll. Cardiol.*, 41:1148–55, 2003.
- Khan, M. Gabriel *Cardiac Drug Therapy*, 6th edition. W. B. Saunders, Philadelphia, 2003, p. 103.
- Pitt, B., Remme, W., Zannad, F. et al. Eplerenone, a selective aldosterone blocker in patients with left ventricular dysfunction after myocardial infarction. *N. Engl. J. Med.*, 348:1309–21, 2003.
- Rousseau, M. F., Guerne, O., Duprez, D. et al. Beneficial neurohormonal profile of spironolactone in severe congestive heart failure. *J. Am. Coll. Cardiol.*, 40:1596, 2002.

Down Syndrome

I. Genetics

II. Incidence of Congenital Heart Malformations

GLOSSARY

atrial septal defect a hole in the wall of the heart (septum) that divides the left and right atrium.

ventricular septal defect a hole in the septum, that divides the left and right ventricles.

I. GENETICS

Down syndrome, trisomy 21 is the most common chromosome abnormality and occurs in approximately 1 in every 650 births. It alone accounts for 1 in 20 congenital cardiac malformations. In virtually all individuals with Down syndrome 47 chromosomes are found with an extra copy of chromosome 21 (trisomy 21), although in approximately 3% of individuals it may originate from an extra copy of all or part of the long arm of chromosome 21 translocated to another chromosome. The recurrence risk is approximately 1% after a child with trisomy 21, and the recurrence is higher if one of the parents carries a translocation.

Increasing maternal age increases the incidence of Down syndrome and prenatal screening has led to a reduction in

its postnatal frequency. The risk rises steeply after age 35 reaching 4% for women older than 44.

II. INCIDENCE OF CONGENITAL HEART MALFORMATIONS

Congenital heart disease occurs in more than 40% of patients with Down syndrome. Malformations include atrioventricular septal defects and approximately 33% of all atrioventricular septal defects are associated with Down syndrome. This congenital defect is referred to as an endocardial cushion defect or atrioventricular canal malformation which results from a defective closure of the endocardial cushions. These are a group of abnormalities unified because of a complete absence of normal atrioventricular septal structures. This is a much more complicated lesion than the more common atrial septal defect and is much more difficult to repair surgically. For more information about atrial septal defects see the chapters Atrial Septal Defect and Embryology. To learn more about ventricular septal defects see the chapter Congenital Heart Disease.

BIBLIOGRAPHY

Pyeritz, R. E. Genetics and cardiovascular diseases. In *Heart Disease*, sixth edition. E. Braunwald, D. P. Zipes, and P. Libby, eds. W. B. Saunders, Philadelphia, 2001.

Dyslipidemia

I. Lipoproteins

GLOSSARY

coronary artery disease same as coronary heart disease; obstruction of the coronary arteries with symptoms such as chest pain, angina, or heart attacks.

hypercholesterolemia elevated cholesterol level.

hypertriglyceridemia elevated triglyceride level.

myocardial infarction death of an area of heart muscle due to blockage of a coronary artery by blood clot and atheroma; medical term for a heart attack or coronary thrombosis.

DYSLIPIDEMIA IS THE TERM MOST FREQUENTLY USED to describe blood lipid abnormalities. Hyperlipidemia, hyperlipoproteinemia, or dyslipoproteinemia are all terms used worldwide to describe dyslipidemia. Hypercholesterolemia describes the elevation of total blood cholesterol and hyperlipidemia describes elevation of a total cholesterol and LDL cholesterol. In the past decade the importance of the smaller HDL cholesterol particle has received much attention, because a very low HDL cholesterol carries a risk for coronary artery disease even when the total cholesterol and LDL cholesterol are relatively normal.

I. LIPOPROTEINS

A. Size

The relative size of plasma lipoproteins according to their hydrated density is shown in Fig. 1. Hydrophobic lipids (cholesterol, cholesteryl esters, phospholipids, and triglycerides) are transported in the blood by lipoprotein particles, which are complex water-soluble particles that provide water-soluble transport packages.

B. Function

Lipoproteins provide a transport for lipids as described below.

1. Transport of cholesterol to organs and tissues; cholesterol is required for the formation of membranes of red blood cells and for the production of steroid hormones. In the liver it is converted to bile acids.
2. Triglycerides absorbed from the intestine are carried to the liver and other sites of utilization and storage.
3. Dietary fatty acids are transported.
4. Food fats are absorbed as fatty acids and packaged into very large lipoproteins called the chylomicrons. These are released from the gut into the portal system of veins that transport blood from the gut to the liver (see Fig. 2).

C. Types

The major circulating lipoproteins are

1. Chylomicron remnants that have a diameter greater than 300 nm and are rapidly cleared from the circulation.
2. Very low density lipoproteins (VLDLs) that carry triglycerides and have a particle diameter between 300 and 800 nm.
3. Low density lipoproteins (LDLs) that carry most of the circulating cholesterol and cholesteryl ester and have a particle diameter of 180–280 nm and a density of 1.019–1.063 (Fig. 1).
4. High density lipoproteins (HDLs) that mainly carry cholesteryl ester; this small particle with diameter 50–90 nm has a high density of 1.063–1.210 g/ml.
5. Lipoprotein(a) is an LDL-like particle that is linked by a disulfhydryl group to a large hydrophilic glycoprotein termed apo(a); recently this particle has been linked to the presence and severity of atherosclerosis, but at present it is not considered to be as important as

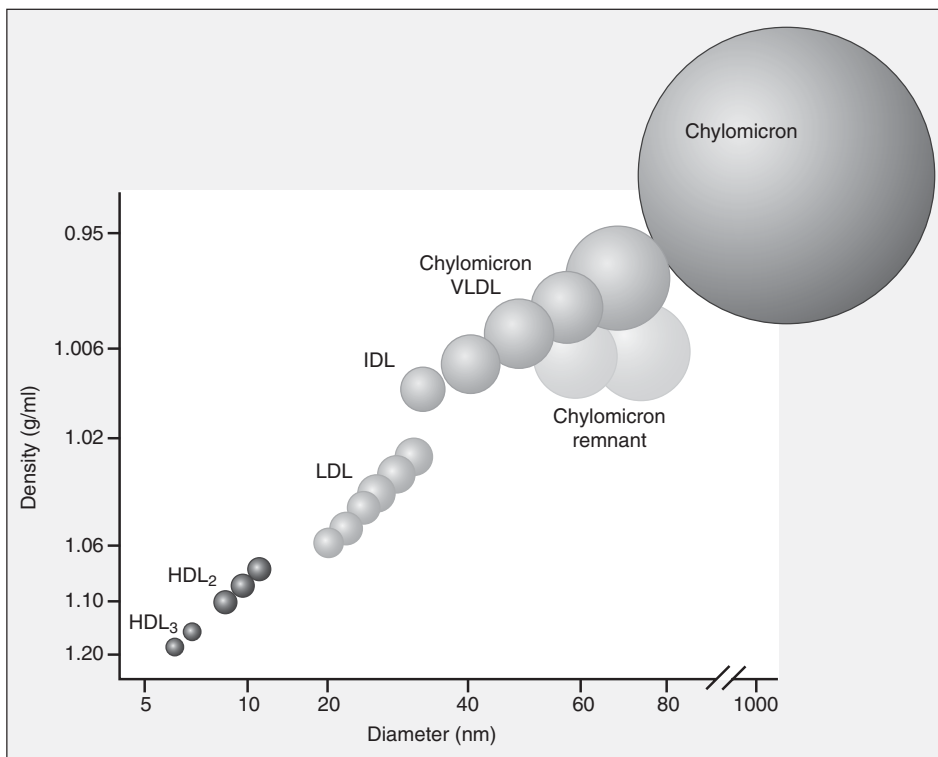

FIGURE 1 Relative size of plasma lipoproteins according to their hydrated density. (From Ridker, P.M., Genest, J., and Libby, P. (2001). Risk Factors for Atherosclerotic Disease. *Heart Disease, 6th ed.*, Braunwald, E., Zipes, D.P., and Libby, P., Eds., Philadelphia: W.B. Saunders, p. 1012. With permission.)

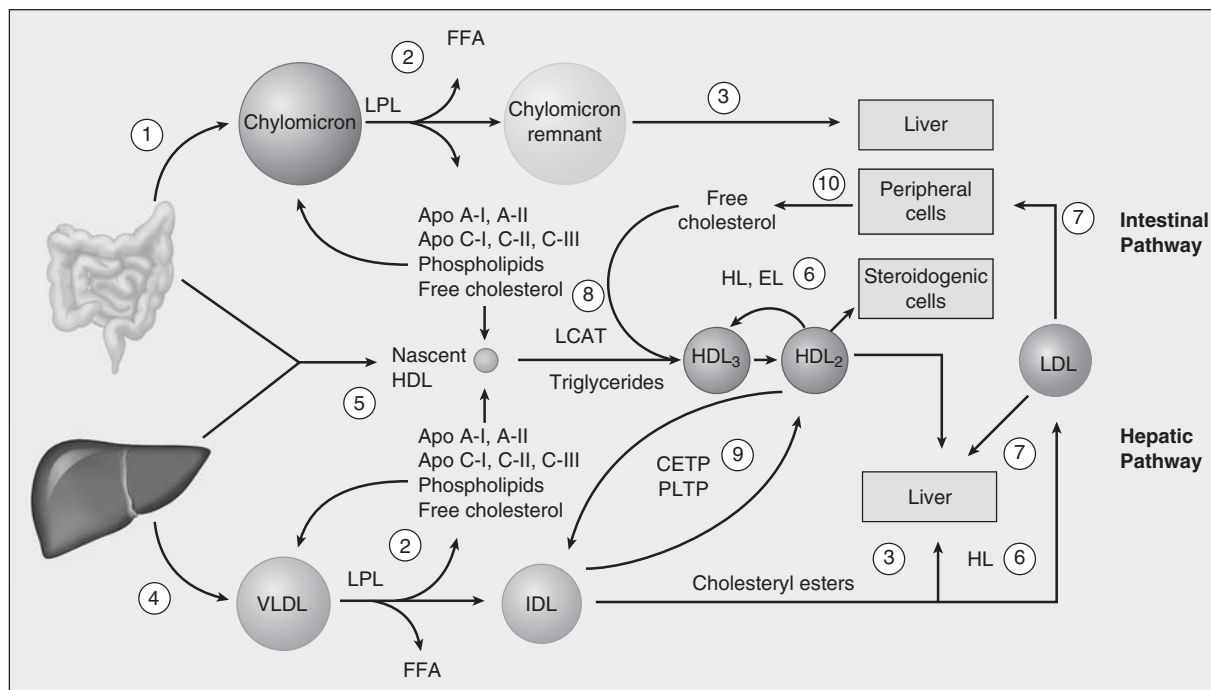

FIGURE 2 Schematic diagram of the lipid transport system. Apo = apolipoprotein; LPL = lipoprotein lipase; HL = hepatic lipase; CETP = cholesteryl ester transfer protein; LCAT = lecithin cholesterol acyl transferase; FFA = free fatty acids; numbers are keyed to explanations in the text. (From Ridker, P.M., Genest, J., and Libby, P. (2001). Risk Factors for Atherosclerotic Disease. *Heart Disease, 6th ed.*, Braunwald, E., Zipes, D.P., and Libby, P., Eds., Philadelphia: W.B. Saunders, p. 1015. With permission.)

LDL cholesterol in the genesis of atherosclerosis and coronary risk.

D. Abnormalities

Dyslipidemias are abnormalities of lipoprotein metabolism. These abnormalities may be caused by genetic disturbances (primary dyslipidemias) or by certain well-defined diseases that are termed secondary dyslipidemias. Figures 3 and 4 show causes of primary and secondary dyslipidemias.

I. Hypertriglyceridemia

Normal blood levels of triglyceride range from 40 to 200 mg/dl (0.45–2.25 mmol/L). The role of elevated blood triglycerides as an independent risk factor for coronary artery disease remains controversial. Chemical determination of triglyceride levels lacks precision, and intervariability and intravariability in measurements are substantial. Most important, hypertriglyceridemia occurs after several clinical conditions without a predictable impact on coronary artery disease risk. Hypertriglyceridemia is often associated with a low HDL cholesterol, however, and a low HDL cholesterol increases coronary risk. Not all epidemiologic studies have described an association between hypertriglyceridemia and coronary risk. A meta-analysis done of six studies of fasting triglycerides and subsequent cardiovascular events in 10,000 women and 46,000 men estimated 37 and 14% increases in risk of coronary artery

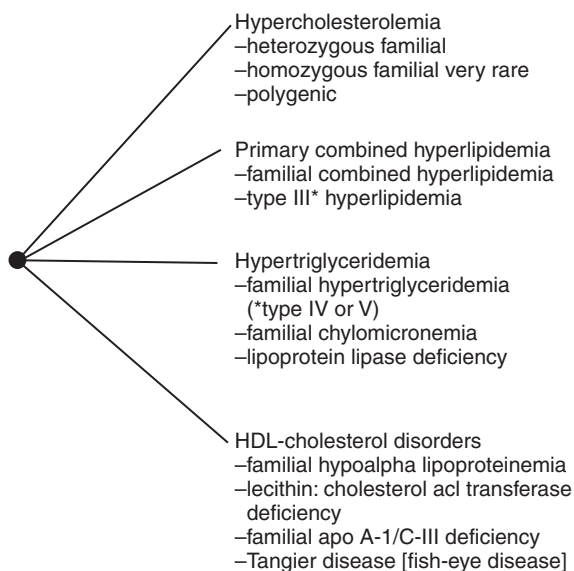

FIGURE 3 Primary dyslipidemias.

disease in women and men, respectively, for every mmol/L increase in triglyceride level, after adjustment for the HDL concentration. Thus it appears that in women older than age 50 hypertriglyceridemia confers a risk for coronary artery disease. Figure 4 indicates that hypertriglyceridemia is commonly associated with diabetes, obesity, and alcohol abuse, all of which are common conditions in the population at large older than 50 years (see the chapter Diabetes and Cardiovascular Disease). Hypertriglyceridemia may rarely occur in families with Frederickson type III, IV, and V hyperlipoproteinemia. In these rare conditions triglyceride levels are markedly elevated (500–2000 mg/dl) and may cause pancreatitis. Hypertriglyceridemia greater than 500 mg/dl causes no symptoms; however, symptoms may be caused by the underlying disease.

The treatment and correction of hypertriglyceridemia is usually not difficult, except in severe elevations that occur in familial disease. Fortunately this is rare and this condition responds dramatically to weight loss and exercise and may be completely reversed so that medications are usually not necessary. This is in contrast to hypercholesterolemia, which unfortunately is not reduced by exercise and weight loss. Hypertriglyceridemia associated with diabetes is often associated with a low HDL cholesterol and mild elevation of total cholesterol. In this situation medications are usually necessary because diabetics are at high risk for coronary artery disease events. In patients where the cause of increased triglyceride levels is due to alcohol abuse, cessation of alcohol consumption causes nearly complete correction of the problem.

When medications are required fibrates such as fenofibrate (Lipidil Supra) produce about a 33% lowering of triglyceride levels. With this agent combined with weight reduction and exercise the abnormality can be corrected.

2. Hypercholesterolemia

Hypercholesterolemia is common in the western world and in the European population. A heterozygous familial entity occurs with markedly elevated cholesterol levels (400–1200 mg/dl) and HDL cholesterol levels with a gene frequency of approximately 1 in 500 individuals. This disorder is one of the more common genetic abnormalities in Caucasians in the United States. These patients have a reduction of 50% of the circulating LDL receptors, which results in an approximate doubling of LDL cholesterol blood levels. Men with this condition usually develop significant and severe coronary artery disease by the third and fourth decade and in women about 7–10 years later. Obstruction by atheromatous plaques may occur in other

	Levels			
	Cholesterol	LDL	HDL	Triglyceride
Diabetes	↑	↑	↓	↑
Hypothyroidism	↑	↑	±	–
Kidney disease	↑	↑	±	–
–nephrotic syndrome	↑	↑	±	–
–glomerulo nephritis	↑	↑	±	–
–chronic renal failure	↑	↑	↓	↑
Liver disease	↑	↑	±	–
–biliary cirrhosis	↑	↑	±	–
–cirrhosis	↑	↑	±	–
–obstructive jaundice	↑	↑	±	–
Alcohol abuse	±	±	↑	↑
Obesity	↑	↑	±	↑
Dietary	↑	↑	±	±
–High saturated fat + trans fatty acid intake	↑	↑	±	±
Medications	↑	↑	↓	↑
–HIV protease inhibitors	↑	↑	±	±
–thiazide diuretic	–	–	↓	↑
–Beta blockers (variable)	±	±	±	↑
–Retinoids	±	±	±	↑
–Corticosteroids	±	±	±	↑

FIGURE 4 Secondary dyslipidemias.

arteries including the abdominal aorta that supplies the legs with blood. The homozygous form of this disorder fortunately is very rare, 1 per million persons, and myocardial infarction has been noted in infants.

In the general population elevations in the range of 220–300 mg/dl are associated with heart attacks. The main causes for this disorder are high intake of saturated fats and trans fatty acids, obesity, and a mild decrease in LDL receptors that mop up cholesterol from the blood. Other causes of dyslipidemias (secondary) are given in Fig. 4. For further discussion of hypercholesterolemia and HDL cholesterol, see the chapter Cholesterol.

E. Drug Management

I. Statins

The management of dyslipidemias has been revolutionized since 1987 with the advent of therapy with statins. For more than 30 years prior to their use controversies raged as to whether an elevated blood cholesterol was the cause of heart attacks and whether this elevation increased the

risk for the development of significant coronary artery disease manifested by angina or heart attacks.

The statins are competitive inhibitors of 3-hydroxy-3-methylglutaryl coenzyme A reductase (HMG-CoA), the key enzyme catabolizing the early rate-limiting step in the biosynthesis of cholesterol within the hepatocyte. Lowering of intracellular cholesterol results in an increase in the number receptors on the hepatocyte through the process of regulation, which results in increased levels of circulating LDL cholesterol and a decrease in total serum cholesterol levels. The statins are currently the most potent, well-tolerated cholesterol agents available. They are capable of causing a 20–40% decrease in total and LDL cholesterol levels.

a. Clinical Studies

The hallmark Scandinavian Simvastatin Survival Study (4S) indicates that long-term treatment for simvastatin is safe and improves survival in patients with coronary artery disease. A total of 4444 patients with angina or previous heart attacks and a total cholesterol 5.5–8 mmol/L were

randomized to a double-blind treatment with simvastatin or placebo. All patients followed a lipid-lowering diet. Over the 5.4 years and median follow up there were 189 cardiac deaths in the placebo group and 111 in the simvastatin (relative risk = 0.58). The number of noncardiovascular deaths was similar in both groups. The treatment group had a 37% reduction in the risk of undergoing revascularization. Long-term simvastatin therapy was associated with a 25% decrease in cholesterol, 35% reduction in LDL cholesterol, and an 8% increase in HDL cholesterol. In this study 79% of patients had a history of previous heart attack.

b. Individuals Statins

The major differences between the five available statins relates to their metabolism in the liver and cytochrome P50 enzymes (atorvastatin, fluvastatin, lovastatin, and simvastatin) and the hydrophilic agents (pravastatin and rosuvastatin) that are eliminated virtually unchanged in the kidney. The agents that use cytochrome P50 pathways may exhibit interactions when used concomitantly with agents such as erythromycin, clarithromycin, azithromycin, cimetidine, and grapefruit juice.

Rosuvastatin, released in 2003, appears to be more powerful than the potent atorvastatin in reducing LDL cholesterol levels. Additionally, it causes a modest decrease in triglyceride levels and an increase in HDL levels. Further discussion of statins and a table giving the generic and trade names of these agents is given in the chapter Cholesterol.

Patients at high risk: acute coronary syndrome, should achieve LDL goal of less than 80 mg/dl (2 mmol/l) and CRP levels lowered to normal regardless of LDL levels. Ridker et al. indicate that CRP monitoring should be used in patients with acute coronary syndrome to assess risk; patients who have low CRP levels after statin therapy appear to have better clinical outcomes than those with higher CRP levels regardless of the level of LDL achieved.

2. Fibrates

The first fibrate introduced worldwide for clinical use in the 1960s, clofibrate, was abandoned after about 10 years because of minor adverse effects and no appreciable effect on coronary artery disease mortality.

a. Gemfibrozil

This agent is a chemical homolog of clofibrate and differs somewhat in mechanism of action and therapeutic effect.

Gemfibrozil decreases production of very low density lipoprotein triglycerides and enhances its clearance. It causes about a 40% reduction in the level of triglycerides, and a 10% increase in HDL cholesterol concentration, but unfortunately as with newer fibrates, it has a negligible effect on lowering total serum cholesterol and LDL blood levels.

b. Bezafibrate and Fenofibrate

These agents are more effective than gemfibrozil and have less adverse effects. Long-acting, once-daily formulations are also available. Micro-coated fenofibrate (Lipidil Supra) 100 and 160 mg once daily are effective formulations that are useful in diabetics with dyslipidemia accompanied by elevations of triglycerides, low HDL cholesterol, and minimal elevations of LDL cholesterol (see the chapter Diabetes and Cardiovascular Disease). These agents have been shown to cause reduced progression and some regression of obstructive atherosclerosis in coronary arteries as measured by angiographic studies. The reduction in mortality caused by these drugs appears to be less than that observed with statins.

3. Cholesterol Absorption Inhibitors

a. Ezetimibe (Zetia; Ezetrol)

This agent is the first of a new class of cholesterol-absorption inhibitors with demonstrated clinical benefits in lipid lowering. This drug localizes to the brush border of the small intestinal enterocyte and inhibits enterocyte cholesterol uptake and absorption. It further inhibits intestinal cholesterol uptake and absorption prior to cholesterol reaching acetyl-CoA-acyltransferase (ACAT) and therefore is not an ACAT inhibitor. A dose of 5–10 mg reduces LDL cholesterol by 16 and 18%, respectively. The major advantage of this new agent is that it can be combined with a statin without the risk of severe muscle damage and kidney failure, whereas the combination of fibrates with statins may cause serious adverse effects, albeit rarely. Coadministration of ezetimibe (10 mg) and simvastatin (40 mg) causes a mean LDL cholesterol lowering of approximately 50%. Although ezetimibe was developed as a single agent, it will find a role in the armamentarium for the management of dyslipidemias when combined with a statin or a fibrate. Most important, in all of the reported studies, the agent has been very well tolerated, either alone or in combination. A useful combination of simvastatin and ezetimibe (Vytorin) is available.

4. Bile Acid Sequestrant Resins

a. Cholestyramine

This agent has been available since the early 1970s. It was rarely used by doctors and patients because of poor compliance. The gritty taste and gastrointestinal side effects with only an approximate 10% reduction in cholesterol and elevation of triglycerides render this agent unsuitable for control of dyslipidemias.

b. Colesevalam

This agent is a new formulation of the bile acid binding resins introduced for use in 2002. The 4.5-mg dose has been shown to reduce LDL cholesterol by 18% and the combination of 2.3 g of the agent with 20 mg of simvastatin reduced LDL cholesterol by 42%, but it increased triglycerides approximately 10%. Thus the drug is not advisable in patients with mixed dyslipidemias. Colesevalam is better tolerated than cholestyramine, but in a study of 240 patients adverse events were similar between each of the groups. It may find a role in patients with pure hypercholesterolemia and LDL elevation. This drug does not have a significant interaction with digoxin, lovastatin, metoprolol, quinidine, or warfarin as is noted with cholestyramine.

5. New Agent

a. Torcetrapib

Torcetrapib increases HDL cholesterol 30 to 50%. Clinical trials are awaited. See chapter entitled Cholesterol.

BIBLIOGRAPHY

- Boekholdt, S. M., Kuivenhoven, J. A., Wareham, N. J. et al. The prospective EPIC (European Prospective Investigation into Cancer and nutrition)-Norfolk population study: Plasma levels of cholesteryl ester transfer protein and the risk of future coronary artery disease in apparently healthy men and women. *Circulation*, 110:1418-1423, 2004.
- CARE: The Cholesterol and Recurrent Events Trial Investigators: The effect of pravastatin on coronary events after myocardial infarction in patients with average cholesterol levels. *N. Engl. J. Med.*, 335:1001-9, 1996.
- Davidson, M. H., McGarry, T., Bettis, R. et al. Ezetimibe coadministered with simvastatin in patients with primary hypercholesterolemia. *J. Am. Coll. Cardiol.*, 40:2125-34, 2002.
- Durrington, P. Dyslipidemia. *Lancet*, 362:717-31, 2003.
- Executive summary of the Third Report of the National Cholesterol Education Program (NCEP) expert panel on detection, evaluation, and treatment of high blood cholesterol in adults (Adult Treatment Panel III). *JAMA*, 85:2486-96, 2001.
- Gotto, A. M., and Brinton, E. A. Assessing the lower levels of high-density lipoprotein cholesterol as the risk factor in coronary heart disease. In a working group report and update. *J. Am. Coll. Cardiol.*, 43:717-724, 2004.
- Graham, D. J., Staffa, J. A., Shatin, D. et al. Incidence of hospitalized rhabdomyolysis in patients treated with lipid-lowering drugs. *JAMA*, 292:2585-2590, 2004.
- Grundy, S. M. et al. Atherosclerosis imaging and the future of lipid management. *Circulation*, 110:3509-3511, 2004.
- Heart Protection Study Collaborative Group. Effects of cholesterol lowering with simvastatin on stroke and other major vascular events in 20,536 people with cerebrovascular disease or other high risk conditions. *Lancet*, 363:757-767, 2004.
- Hokanson, J. F., and Austin, M. A. Plasma triglyceride level is a risk factor for cardiovascular disease independent of high density lipoprotein cholesterol level: A meta-analysis of population based on respective studies. *J. Cardiovasc. Risk*, 3:213-19, 1996.
- Khan, M. G. Management of hyperlipidemias. In *Cardiac Drug Therapy*, sixth edition, W. B. Saunders, Philadelphia, 2003.
- LIPID: The long term intervention with pravastatin in ischaemic disease (LIPID) Study Group. Prevention of cardiovascular events and death with pravastatin in patients with coronary heart disease and a broad range of initial cholesterol levels. *N. Engl. J. Med.*, 339:1349-57, 1998.
- Nissen, S. E., Tsunoda, T., Tuzcu, E. M. et al. Effect of recombinant ApoA-I Milano on coronary atherosclerosis in patients with acute coronary syndromes: A randomized controlled trial. *JAMA*, 290:2292-2300, 2003.
- Nissen, S. E., Tuzcu, E. M., Schoenhagen, P. et al. For the reversal of atherosclerosis with aggressive lipid lowering (REVERSAL) investigators statin therapy, LDL cholesterol, C-reactive protein, and coronary artery disease. *N. Engl. J. Med.*, 352:29-38, 2005.
- Pietinen, P., and Huttunen, J. K. The dietary determinants of plasma high density lipoprotein cholesterol. *Am. Heart J.*, 113:620-25, 1987.
- Ridker, P. M., Cannon, C. P., Morrow, D. et al. For the Pravastatin or Atorvastatin Evaluation and Infection Therapy-Thrombolysis in Myocardial Infarction 22 (PROVE IT-TIMI 22) Investigator: C-reactive protein levels and outcomes after statin therapy. *N. Engl. J. Med.*, 352:20-28, 2005.
- Scandinavian simvastatin survival Study group: Randomized trial of cholesterol lowering in 4444 patients with coronary heart disease: The Scandinavian simvastatin survival study (4S). *Lancet*, 344:1383, 1994.
- Shepherd, J., Cobbe, S. M., Ford, I. et al. Prevention of coronary heart disease with pravastatin in men with hypercholesterolemia. *N. Engl. J. Med.*, 333:1301, 1995.
- Toth, P. P. et al. The "good cholesterol": High-density lipoprotein. *Circulation*, 111:e89-e91, 2005.
- Yonemura, A., Momiyama, Y., Zahi, A., Fayad, Z. A. et al. Effect of lipid-lowering therapy with atorvastatin on atherosclerotic aortic plaques detected by noninvasive magnetic resonance imaging. *J. Am. Coll. Cardiol.*, 45:733-74, 2005.

Echocardiography

- I. Historical
- II. Instrumentation
- III. Echocardiographic Examination
- V. Research Implications
- VI. New Frontiers

GLOSSARY

heart failure failure of the heart muscle to pump sufficient blood from the chambers into the aorta; inadequate supply of blood reaches organs and tissues.

hypokinesia decreased myocardial contraction usually caused by damage and weakness of the heart muscle due to coronary artery disease and cardiomyopathies.

ischemia temporary lack of blood and oxygen to an area of cells, for example, the heart muscle, usually due to severe obstruction of the artery supplying blood to this area of cells.

mitral regurgitation the mitral valve remains open when it should be completely shut; blood rushes backwards from the left ventricle into the left atrium.

myocardial infarction death of an area of heart muscle due to blockage of a coronary artery by blood clot and atheroma; medical term for a heart attack or coronary thrombosis.

I. HISTORICAL

The Titanic disaster of 1912 led to the impetus for detecting structures under the sea. In 1940 during World War II ultrasonic floor detectors were developed for tracking enemy submarines. In 1945 with the end of the war, attention was turned to imaging of body parts instead of tracking submarines and technologic developments advanced.

A. W. D. Keidel

In 1950 this German investigator attempted to study the heart using ultrasound. He used transmission ultrasound

and obtained an acoustic shadow of the heart that varied with cardiac volume.

B. Inge Edler and Helmut Hertz

Beginning in 1953 Helmut Hertz, a physicist, borrowed a sonar device from a local shipyard, and this led to an electronic firm developing an ultrasonic reflectoscope. Hertz collaborated with Inge Edler, a cardiologist, in Sweden. Dr. Edler became fascinated with echoes that arose from the mitral valve leaflets and in 1960 at the European Congress of Cardiology he presented a movie depicting the mitral valve findings. He showed for the first time that cardiac ultrasound was capable of showing other parts of the heart including the aortic valve and aorta. The cardiac ultrasound was particularly effective in showing fluid in the pericardial sac (pericardial effusions). Dr. Edler and Hertz are the recognized developers of cardiac ultrasound, but neither Hertz or Edler, who died in 2001, pursued this work after 1960.

C. Jack Reid, John Wild, and Claude Joyner

Reid, an engineer, worked with Wild and used cardiac ultrasound to study the heart. While completing his doctorate at Pennsylvania, Reid collaborated with Dr. Joyner, a radiologist, and duplicated Dr. Edler's observations of mitral stenosis using cardiac ultrasound. The publication of this work in the journal *Circulation* and the hosting of the instrument at the American Heart Association meeting in 1963 stimulated a vast number of investigators, and one in particular, Dr. Harvey Feigenbaum.

D. Harvey Feigenbaum

Dr. Harvey Feigenbaum stated in an article published in the *American College of Cardiology* journal review in October 2001 that he was very disappointed when he viewed the instrument at the American Heart Association

meeting in 1963. But fortunately he placed the transducer on his chest and observed an echo coming from the back of his heart. He asked the salesperson what would happen if there was fluid behind the heart. The technician replied that fluid should be echo-free. Dr. Feigenbaum asked whether the instrument could detect pericardial effusions, but the salesperson did not know. This answer sparked Dr. Feigenbaum's interest enough to continue studying this technology.

Dr. Feigenbaum states that he borrowed an echograph from his neurology colleagues. The echograph was used for detecting the midline structures of the brain. With this equipment he was able to record the echo from the back of the heart. He then selected a patient with a pericardial effusion and as predicted, he located the echo-free space. Dr. Feigenbaum confirmed the detection of pericardial effusions in dogs. In the 2001 article "History of Echocardiography," Dr Feigenbaum stated that "the work was published in March 1965 in the *Journal of the American Medical Association*."

E. Recent Era

From the initial M-mode echocardiography, the 2-D mode evolved in 1970. The development of Doppler technology advanced the method considerably. We now have 2-D, spectral Doppler, color Doppler, transesophageal early three-dimensional echocardiography, and intravascular ultrasound.

Doppler echocardiography is based on the Doppler effect first described by Christian Johann Doppler in 1842. He demonstrated that the frequency of sound reflected from an object is altered if that object is moving. The Doppler effect is, in essence, a change or shift in frequency in relation to the direction of movement of its source. The movement of blood cells produce a Doppler shift of ultrasound frequencies. The extent and direction of shift of the ultrasound and the frequency are related to the velocity and direction of blood flow.

More recently, advances in electronics have enabled contrast echocardiography, harmonic and strain imaging, and the production of an echocardiography machine the size of a laptop computer. Handheld echocardiography is the newest evolution.

The information derived from echocardiographic examination of the heart has revolutionized the clinical practice of medicine. Presently there is one important diagnosis, however, that the echocardiogram is not able to make. The obstruction of coronary arteries by atheroma that causes angina and fatal and nonfatal heart attacks cannot

be visualized on echocardiography. Intravascular ultrasound done at the time of interventional procedures is improving our knowledge of the atherosclerotic process and its complications, but this technique cannot be applied in clinical practice. Recent developments are concentrating on the visualization of the left anterior coronary artery using transthoracic echocardiography.

II. INSTRUMENTATION

Ultrasound is sonic energy with a frequency higher than the audible range of 20,000 Hz. The development of piezoelectric transducers made the application of ultrasound possible. A piezoelectric (pressure electric) element is the primary component of an ultrasonic transducer. The shape of a quartz crystal varies with its polarity when an electric current is impressed through the crystal. The expansion and contraction of the crystal produces compressions and rarefactions or sound waves. Most important, when the crystal is struck by reflected ultrasound waves, the crystal creates ultrasound energy and then produces an electric impulse or signal.

Ultrasound, like light, can be focused into a beam that obeys the laws of reflection and refraction. An ultrasound beam travels in a straight line when it traverses a medium of homogeneous density. When the beam hits an interface of different acoustic impedance, part of the energy is reflected. This reflected energy is used to construct an image of the heart.

Figure 1 shows a block diagram of the components of an ultrasonic echograph. The instrument is used to create an image using ultrasound.

III. ECHOCARDIOGRAPHIC EXAMINATION

A. Echocardiographic Window

Because sound travels poorly through a gaseous medium, it is impossible for ultrasound to traverse the voluminous lung tissue and still obtain adequate echoes from the heart. The transducer must also not be placed over the sternum or ribs or other bony points. Almost all ultrasonic energy is reflected if one tries to direct an ultrasonic beam through bone. Because of the rib cage and breast bone, the best echocardiographic window lies between the second and fifth intercostal spaces and 3–4 cm to the left of the left sternal border.

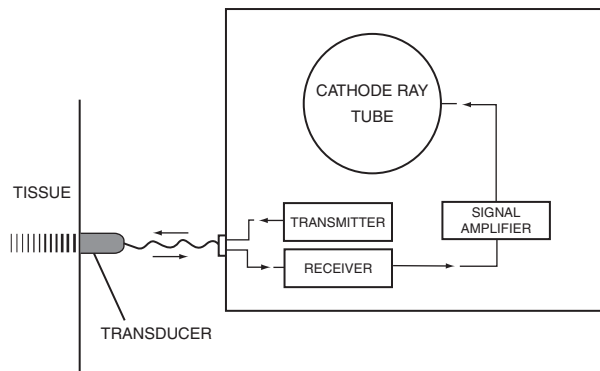

FIGURE 1 Block diagram of the components of an ultrasonic echograph. (From Feigenbaum, H., *Echocardiography*, fourth edition, Philadelphia: Lea & Febiger, 8, 1986.)

B. Transthoracic Echocardiogram

The standard transthoracic echocardiogram provides views of the heart with the transducer position on the left chest wall. It gives an adequate visualization of the structures of the heart and abnormalities in more than 95% of patients with valvular heart disease, heart attacks, ischemic heart disease, heart failure, cardiomyopathy, hypertensive heart disease, and assessment of left ventricular hypertrophy. It is, however, not satisfactory for complicated problems in which a transesophageal echocardiogram (TEE) is required.

C. Transesophageal Echocardiogram

TEE is superior to transthoracic echocardiography because the transducer is placed in the esophagus. The esophagus lies immediately behind and adjacent to the left atrium and the thoracic aorta. Specific indications for TEE include congenital heart disease, detection of thrombi in the left atrium, vegetations on the heart valves that occur in infective endocarditis, and for the evaluation of prosthetic heart valves in these situations.

Figure 2 shows the visualization of the heart's basic imaging planes by previous transducer positions. Figure 3 shows a two-dimensional image of the heart and the parasternal long axis view. The cardiac chambers correlate with the diagram in Fig. 2. Figure 4 shows an apical, four-, and two-chamber view.

IV. CLINICAL APPLICATIONS

Echocardiographic evaluation of heart disease is used extensively to verify many clinical diagnoses and assists

with the formulation and timing of treatment strategies. The following are some of these clinical entities.

A. Valvular Heart Disease

I. Mitral Valve Disease

a. Mitral Stenosis

This disease involves a tight mitral valve that restricts blood flow from the left atrium into the left ventricle. Echocardiographic examination can estimate the degree and state of stenosis. If the stenosis is mild the valve area = $1.6\text{--}2.0\text{ cm}^2$, in moderate mitral stenosis the valve area = $1\text{--}1.5\text{ cm}^2$, and in severe stenosis the valve area = $< 1\text{ cm}^2$.

b. Mitral Regurgitation

Mitral regurgitation (mitral valve incompetence) consists of a leaking or incompetent valve that includes mitral valve prolapse. It is difficult to decide from the history and physical examination whether surgery is necessary in some patients. Echocardiographic evaluation is extremely useful, especially TEE, to evaluate severe degrees of regurgitation, disruption of the chordae (tendinous cords that hold the mitral valve in place), and a flail mitral valve leaflet that might require urgent surgical correction (see chapter entitled Valve Diseases).

c. Aortic Valve Stenosis

In aortic stenosis, a severely tight valve with an area less than 0.75 cm^2 usually causes severe shortness of breath, syncope, chest pain, or heart failure, and implantation of a new valve is frequent. Echocardiographic follow up of patients with moderate degrees of stenosis is most useful to clinicians. Pulmonary and tricuspid valve defects and prosthetic heart valve dysfunction are disease entities that can also be visualized with use of TEE.

B. Thrombi

Thrombi (clots in the heart) occur in the left atrium and are common in patients with atrial fibrillation. TEE visualization of thrombi is superior to transthoracic visualization. A thrombus may form in the cavity of the left ventricle after a heart attack and this can be visualized by the simple transthoracic echo.

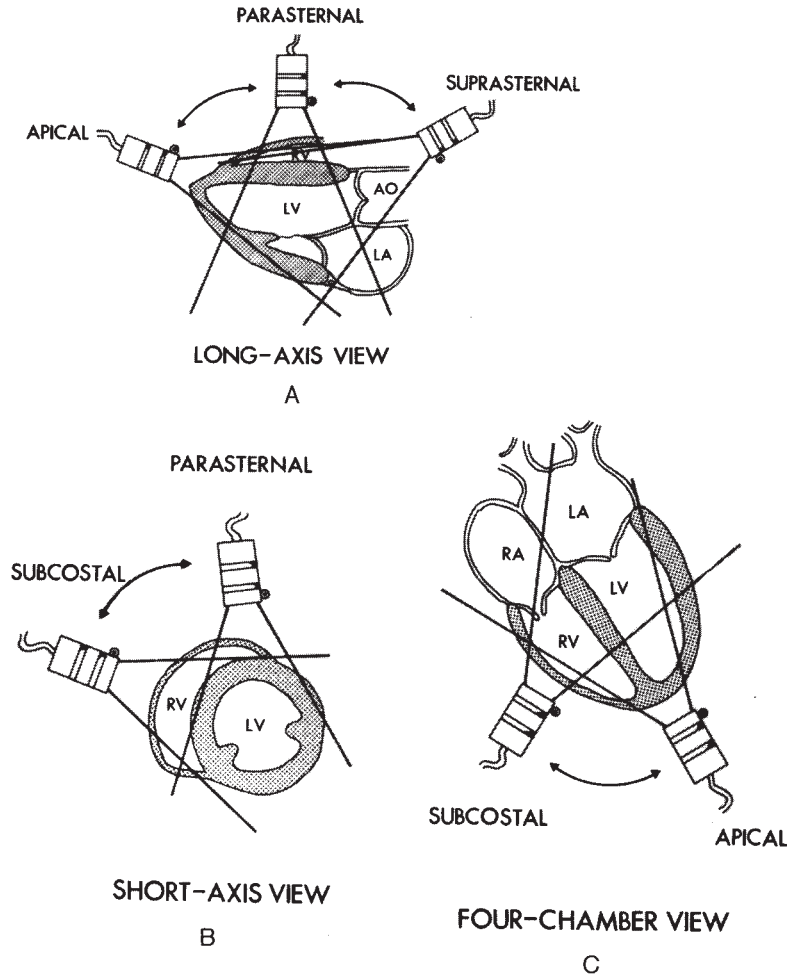

FIGURE 2 Visualization of the heart's basic tomographic imaging planes by various transducer positions. The long-axis plane (A) can be imaged in the parasternal, suprasternal, and apical positions; the short-axis plane (B) in the parasternal and subcostal positions; and the four-chamber plane (C) in the apical and subcostal positions. (From Rosendorff, C., *Essential Cardiology*, Philadelphia: W. B. Saunders, 145, 2001.)

C. Congenital Heart Disease

Congenital heart defects have been a difficult diagnostic area for cardiologists and echocardiography is a dream come true. Figure 5 depicts a ventricular septal defect (see the chapter Congenital Heart Disease). Most important, careful echocardiographic assessment of the heart can give hemodynamic data that are identical with right and left heart catheterization thus avoiding invasive catheterization in many cases.

D. Coronary Artery Disease

Coronary artery disease causes a heart attack and the damage and weakness of the muscle can be detected by echocardiography. Severe narrowing of a coronary artery

may cause transient chest pain and angina caused by transient but severe deprivation of blood supply to the heart muscle. In these patients an echocardiogram may reveal regional abnormal left ventricular wall motion abnormalities.

E. Heart Failure

The most common cause of heart failure is severe weakness to the entire left ventricular muscular wall. Echocardiographic assessment reveals poor contraction of the muscle (global hypokinesis). The amount of blood ejected from the heart (ejection fraction) normally exceeds 55%. This may be observed to be less than 40% or less than 25% in severe cases of heart failure.

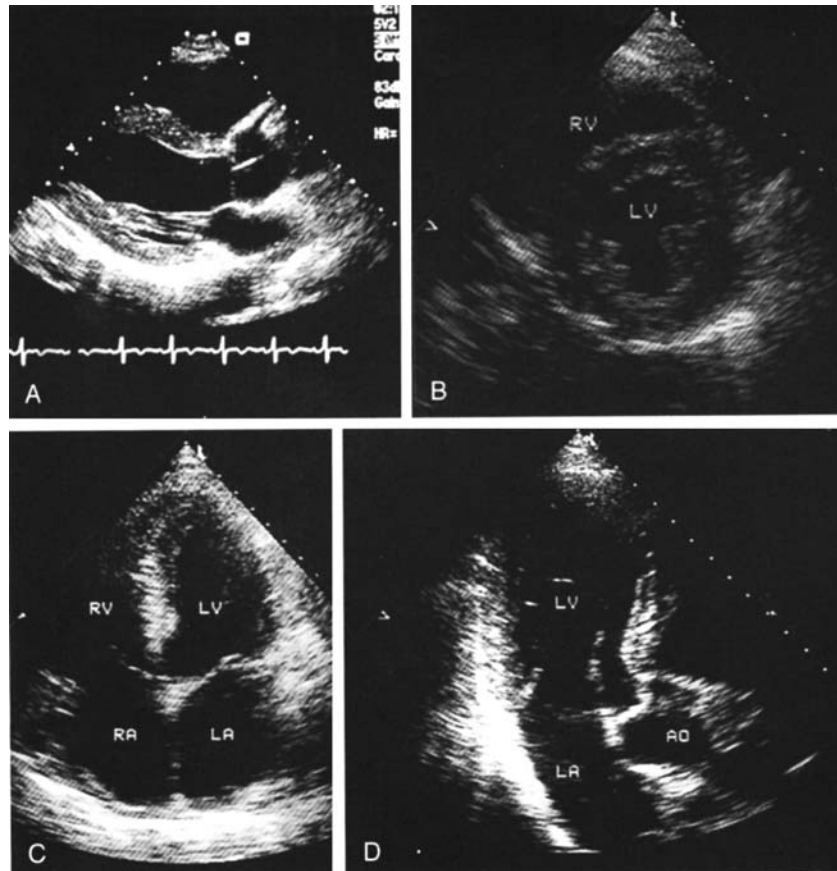

FIGURE 3 (A) Two-dimensional image of the heart in the parasternal long-axis view. (B) Short-axis plane through the heart at the level of the papillary muscle. (C) Two-dimensional image of the apical four-chamber plane. (D) Two-dimensional image of the apical three-chamber plane. (From Rosendorff, C., *Essential Cardiology*, Philadelphia: W. B. Saunders, 145, 2001.)

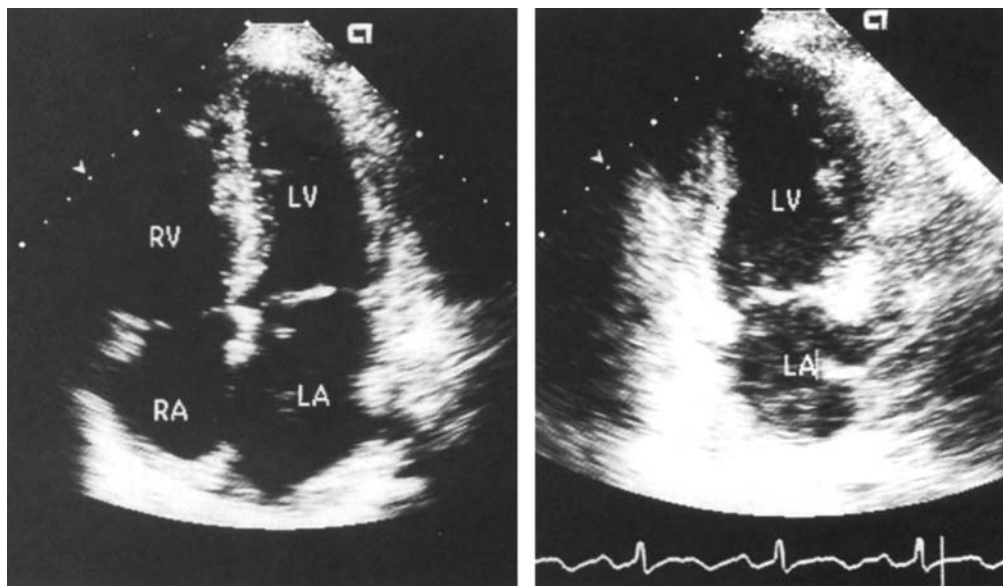

FIGURE 4 Apical four- and two-chamber views of the left ventricle. Note the normal “bullet shape” geometry of the left ventricle and the more triangular right ventricle. Note also the more apical insertion of the tricuspid valve compared with the mitral valve. (From Braunwald, E., Zipes, D.P., and Libby, P., *Heart Disease: A Textbook of Cardiovascular Medicine*, Philadelphia: W. B. Saunders, 2001.)

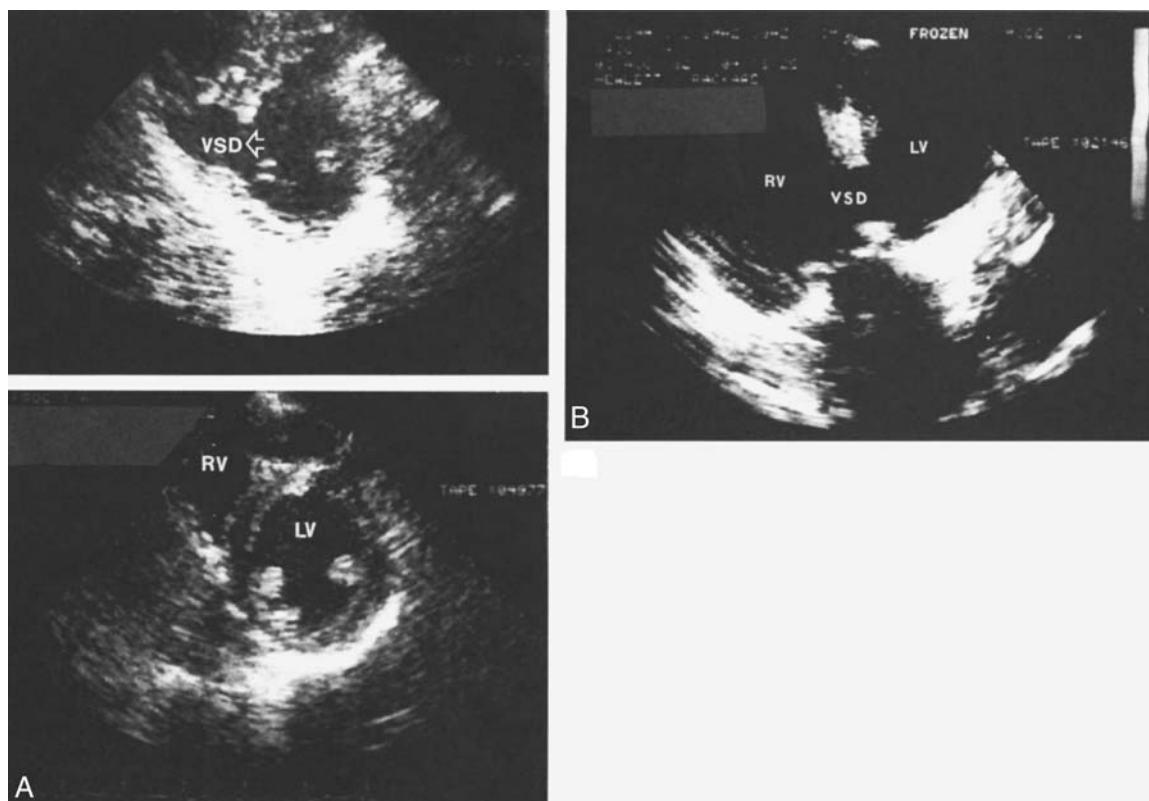

FIGURE 5 Two-dimensional images from two patients with ventricular septal defect. (A) Two parasternal short axis frames. The lower frame is through the level of the papillary muscles and at this point the interventricular septum is intact. As the beam is scanned superiorly the ventricular septal defect (VSD) is visualized. (B) A large ventricular septal defect seen in the apical four-chamber view. (From Julian, D.G., Ed., *Diseases of the Heart*, London: W.B. Saunders, 325, 1996.)

F. Other Clinical Indications

With pericardial effusion there is fluid in the pericardial sac. This is readily detected on echocardiography and followed during treatment. Echocardiography has proved most useful in the diagnosis of cardiac tamponade, in which a large pericardial effusion compresses the heart and prevents its filling. This results in cardiogenic shock or death. Another clinical indication for echocardiography is infective endocarditis. This is an infection of the heart valves that produces vegetations or clumps of bacteria. These vegetations may grow on the valve leaflets and can range from millimeters to a centimeter. These vegetations can be detected with TEE.

Hypertensive heart disease causes enlargement or hypertrophy of the heart that can be detected with echocardiography. Hypertrophic cardiomyopathy can also be readily assessed with this technology (see the chapters Cardiomyopathy and Athlete's and Sudden Cardiac Death) along with dilated cardiomyopathy, and muscle damage

caused by cancer chemotherapeutic agents can be defined. Finally, dissecting aneurysms, myxomas, and other tumors can be easily diagnosed using TEE technology.

V. RESEARCH IMPLICATIONS

The very important role of echocardiography in the practice of cardiology has been outlined above. There is one important diagnosis, however, that the echocardiogram is not able to resolve adequately. The obstruction of coronary arteries by atheroma, which causes angina and fatal and nonfatal heart attacks and accounts for more than 90% of deaths from coronary artery disease cannot be visualized with this technology. Intravascular ultrasound done at the time of interventional procedures is improving our knowledge of the atherosclerotic process and its complications, but this technique cannot be applied in clinical practice.

VI. NEW FRONTIERS

A. Transthoracic Visualization of the Coronary Artery

In a pertinent review done in 2003, Drs. Gradus-Pizlo and Feigenbaum outlined the potential use of high-resolution, two-dimensional transthoracic echocardiography (HR-2DTTE) for visualization of the left anterior descending coronary artery (LAD). They indicated that the difference in the LAD wall thickness between patients with coronary artery disease and in patients with normal coronary arteries can be detected. Measurements of the LAD wall thickness with this method are larger than measurements obtained by intravascular ultrasound and histology. This thickness increases significantly with the development of atherosclerosis. This technique, when crystallized, could be recommended for the detection of subclinical atherosclerosis for which there are presently no adequate noninvasive applicable tests.

A noninvasive, reliable method to identify subclinical coronary artery disease in asymptomatic individuals at risk would be a dream come true and would add great dimensions to our diagnostic armamentarium. HR-2DTEE and its refinements has this potential.

B. Handheld Instruments

Presently weighing about 5 pounds, these instruments are due to trim down to a one-pound weight and hopefully can be reduced further to 1 g in the future. Miniaturization using 3-D and 4-D parametric imaging can show areas of myocardial infarction. Ultrasound-guided focused ablation technology for arrhythmias and other potentials are also on the horizon.

BIBLIOGRAPHY

- DeMaria, A. N., and Blanchard, D. G. The echocardiogram. In *Hurst's The Heart*, 9th edition. R. C. Schlant, R. W. Alexander, and V. Fuster, eds. McGraw-Hill, New York, 415–517, 1998.
- Feigenbaum, H. Evolution of echocardiography. *Circulation*, 93:1321–7, 1996.
- Feigenbaum, H. History of echocardiography. *J. Am. Coll. Cardiol. ACC Curr. Rev. Sept/Oct 42*, 2001.
- Gradus-Pizlo, I., and Feigenbaum, H. Potential use of high-resolution two-dimensional transthoracic echocardiography for visualization of the left anterior descending coronary artery. *Am. Heart Hosp. J.*, 1:77–82, 2003.
- Mason, W. P. *Piezoelectric Crystals and their Application to Ultrasonics*. Van Nostrand, New York, 1950.
- Schiller, N. B. Handheld echocardiography: Revolution or hassle? *J. Am. Coll. Cardiol.*, 37:2023–24, 2001.

Effects of Smoking and Heart Disease

- I. Effects of Components of Cigarette Smoke
- II. Cigarette Smoke and Atherosclerosis
- III. Recent Epidemiologic Study
- IV. Anginal Chest Pain and Impotence
- V. Habituation and Cessation

GLOSSARY

arrhythmia general term for irregularity or rapidity of the heartbeat.

atherosclerosis a hardened plaque in the wall of an artery: the plaque is filled with cholesterol calcium and other substances. The plaque of atheroma hardens the artery hence the term atherosclerosis (sclerosis equals hardening).

myocardial infarction death of an area of heart muscle due to blockage of the coronary artery by blood clot and atheroma (atherothrombosis), medical term for a heart attack.

Epidemiologic Studies strongly support the hypothesis that cigarette smoking increases the incidence of fatal and nonfatal heart attacks. But, despite a world full of researchers, the exact constituent which resides in cigarette smoke and the pathophysiologic mechanisms responsible for cardiac events remain unknown. Ambrose *et al.*, in an informative review, emphasize the lack of clear answers.

Low-tar cigarettes and smokeless tobacco have been shown to increase the risk of cardiovascular events in comparison to nonsmokers. Passive smoke is associated with about a 30% increase in risk of cardiac events compared with an 80% increase in active smokers. A smoke free environment in several cities reportedly has resulted in a decreased incidence of cardiac events. It is believed that if cigarette smoking were eliminated, about a quarter of a million lives now lost because of cardiovascular disease could be saved yearly in North America. Each year, lung cancer causes about 80,000 deaths. Smoking causes most cases of lung cancer, which is becoming the leading cause of death from cancer in women.

Nonsmoking men age 45–55 are 10 times less likely to have a fatal or nonfatal heart attack than heavy smokers. The Multiple Risk Factor Intervention Trial showed that men at high risk who stopped smoking had a significant reduction in their mortality.

The detrimental effects of cigarette smoking were widely advertised in the mid-1970s, and since then more than 20 million North Americans have stopped smoking. Smoking has increased in teenagers and women, however, resulting in little change in the overall number of smokers. Heart attacks are rare in women aged, 40–48, but in women of this age who use oral contraceptives and smoke, the heart attack rate is increased. Over the past two decades cigarette smoking has increased considerably in Japan, China, India, Russia, its former territories, and the developing world. Cardiovascular events are on the increase in these countries.

Low-nicotine, low-tar brands, or filter cigarettes do not decrease the risk of coronary heart disease, although the risk of lung cancer may be decreased. Filter cigarettes deliver more carbon monoxide and cause a higher incidence of coronary heart disease than do plain cigarettes.

I. EFFECTS OF COMPONENTS OF CIGARETTE SMOKE

Tobacco smoke contains more than 4000 components. Some of these are nicotine, carbon monoxide, ammonia, benzene, nitrobenzene, phenol, 2,4-dimethylphenol, acetaldehyde, hydrogen cyanide, toluene and O-cresol. Most studies have been done on nicotine and various gases, in particular, carbon monoxide (CO).

Although the effects of the many constituents of smoke are not understood, the effect of nicotine is well documented.

Cigarette smoke is divided into two phases:

- A tar phase: defined as the material that is trapped when the smoke stream is passed through the Cambridge glass-fiber filter that retains 99.9% of all particulate material with a size $>0.1 \mu\text{m}$.
- A gas phase: the material that passes through the filter.

A. Nicotine

Nicotine stimulates the adrenal glands to put out excessive adrenaline and noradrenaline. The higher the nicotine concentration inhaled, the greater the outpouring of adrenaline. If someone puts a gun to your head, you need all the adrenaline and noradrenaline that your adrenals and nerves can produce to enable you to fight or run. So adrenaline is great stuff, but it has many harmful effects. The heart rate and blood pressure increase, which means more work for the heart. The heart muscle will also require a bigger supply of oxygen. The platelets become sticky and may clump onto the surface of atheromatous plaques in one of your coronary arteries and a heart attack can occur.

Nicotine, by increasing the heart rate and blood pressure, can increase the frequency and duration of chest pain in those who have angina.

Nicotine can and does increase the excitability of heart muscle, causing premature beats that can lead to serious disturbance in heart rhythm (arrhythmias). Sudden cardiac death is more common in heavy cigarette smokers.

In individuals with seizures, the brain cells have a threshold level at which seizures occur. If this threshold is not reached, seizures do not occur. Drugs including alcohol decrease this threshold and seizures are more easily produced; we can prevent seizures by elevating the threshold. Drugs used to treat epilepsy, for example phenytoin (Dilantin), increase the threshold, therefore preventing seizures. Two products of cigarette smoke, nicotine and carbon monoxide, decrease the ventricular fibrillation threshold of the heart muscle. The ventricular fibrillation threshold is decreased if the heart muscle is suddenly deprived of blood, or exposed to high concentrations of adrenaline, noradrenaline, and other drugs. During a heart attack, high amounts of noradrenaline are found in and around the damaged muscle and can cause ventricular fibrillation. During ventricular fibrillation the muscle no longer contracts, but quivers. Therefore, the heart is at a standstill — no blood is being pumped. The heart stops beating, the brain dies; thus there is heart and brain death.

The ventricular fibrillation threshold is slightly increased by only one or two available heart drugs. Beta-blockers counteract the effects of adrenaline and noradrenaline at the cell surface and increase the ventricular fibrillation threshold.

Nicotine causes a smoking-related increase in cardiac output, heart rate, and blood pressure, but these do not relate to the development of atherosclerosis or its complications, including thrombosis. Nicotine exposure alone had been reported to cause no change, a decrease, or an increase in endothelium-dependent vasodilation or NO availability.

Nevertheless smokers are inhaling two dangerous compounds, carbon monoxide and nicotine, as well as other gases that decrease the ventricular fibrillation threshold and therefore are capable of causing death. The habituation, “addiction” effects of nicotine are overwhelming.

B. Carbon Monoxide

The hemoglobin of red blood cells transports oxygen to all cells and tissues of the body. Hemoglobin clings to carbon monoxide about 200 times more readily than the oxygen circulating in the blood. In this situation oxygen clings strongly to whatever hemoglobin it can find, and less oxygen is released to the cells. Carbon monoxide combines with hemoglobin to form a compound called carboxyhemoglobin. The tissues, therefore, including the heart muscle cells, are deprived of oxygen. This is particularly important if the cells are already undernourished and lack oxygen because of severe narrowing of the coronary arteries by atheromatous plaques. These plaques are present in more than 50% of North Americans age 35 and over. Only about 30% of the adult population are spared from the dreadful atheromatous blockage in arteries that cause coronary heart disease.

Carboxyhemoglobin likely causes the wall of the arteries to be more permeable to fats including cholesterol, and this can speed up atheroma formation. Individuals with carboxyhemoglobin levels greater than 5% are 21 times more likely to develop heart attacks or poor circulation in the arteries of the legs than individuals with levels less than 3%. There is scientific evidence indicating that heavy cigarette smokers are subjected to eight times the carbon monoxide exposure allowed in industry.

A sane individual would *certainly not stay in a closed garage with the engine running knowing the danger of carbon monoxide is death.*

High-nicotine or nonnicotine cigarettes produce the same amount of carbon monoxide. Stickiness of the platelets is also increased by carbon monoxide, thus increasing the chance of clotting in the coronary arteries. The ventricular fibrillation threshold of the heart muscle and its electrical tissues is reduced by carbon monoxide; thus sudden death may not be a mystery.

The effect of carbon monoxide on the development of atherosclerosis and its complications is reportedly equivocal. Recently, however, Hedblad *et al.* reported that heterogeneity of cardiovascular risk among smokers is related to a degree of carbon monoxide exposure: the incidence of a new vascular disease events and deaths increased progressively with the degree of CO exposure. Men with CO in the top quartile had significantly

increased risks of a new cardiovascular disease events (RR: 2.2; 95% CI: 1.00–4.6) and cardiovascular deaths (RR: 3.2, CI: 1.2–8.3), adjusted for daily tobacco consumption and other potential confounders. Hedblad *et al.* point out: In smokers, the prevalence of leg atherosclerosis and incidence of cardiovascular disease is related to the amount of carbon monoxide in blood or expired air.

C. Tar fraction

Polycyclic aromatic hydrocarbons found in the tar fraction of cigarette smoke, however, in experimental models, accelerate atherosclerosis.

II. CIGARETTE SMOKE AND ATHEROSCLEROSIS

A. Nitric Oxide and Vasodilatory Function

Impairment of vasodilatory function is one of the earliest manifestations of atherosclerotic changes in arteries. In both animal and human models, studies by Celermajer *et al.* and other investigators have demonstrated that both active and passive cigarette smoke exposure were associated with a decrease in vasodilatory function. In humans, cigarette smoke exposure has been shown to impair endothelium-dependent vasodilation in macrovascular beds such as coronary and brachial arteries and in microvascular beds. Nitric oxide (NO), a free radical, is primarily responsible for the vasodilatory function of the endothelium. Using cigarette smoke extract or isolated components such as nicotine, multiple *in vitro* studies have found that cigarette smoke was associated with decreased NO availability.

B. Oxidation of LDL Cholesterol

Cigarette smoke experimentally increases vascular inflammation, thrombosis, oxidation of LDL cholesterol, and oxidative stress. Nishio *et al.* indicated that cigarette smoke extract exposure appears to decrease the plasma activity of paraoxonase, an enzyme that protects against LDL oxidation. In a hyperlipidemic rabbit model, Yamaguchi *et al.* have shown injection of cigarette smoke accelerated atherosclerosis through oxidative modification of LDL.

Burke *et al.*, in pathologic studies of sudden coronary death indicate that cigarette smoke increased the risk of plaque rupture and acute thrombosis of a lipid-rich, thin-capped atheroma in men; in female smokers, the prevailing mechanism was plaque erosion with superimposed

thrombosis. In addition, smoking may also be a risk factor for coronary vasoplasm.

C. Genetic Predisposition

Genetic predisposition influences the development of atherosclerosis in individuals exposed to cigarette smoke. The intersubject variability in the atherosclerotic process in smokers may be partially mediated by genetic variants. Either CYP1A1 MSP polymorphism or certain endothelial NO synthase intron 4 polymorphisms increased the susceptibility to cigarette smoke. *In vivo*, cigarette smoke is associated with an increased level of multiple inflammatory markers including C-reactive protein, interleukin-6, and tumor necrosis factor alpha in both male and female smokers.

D. Platelet Dysfunction and Thrombotic Factors

Rival *et al.* have shown that platelets isolated from smokers exhibited an increased stimulated as well as spontaneous aggregation. A higher fibrinogen blood level found in smokers correlates with the number of cigarettes smoked. Hirohiko *et al.* observed only 2-week smoking cessation improves platelet aggregability and intraplatelet redox imbalance of long-term smokers.

III. RECENT EPIDEMIOLOGIC STUDY

In the recently published INTERHEART study reported by Yusuf *et al.*: “risk factors were significantly ($p < 0.0001$) related to acute myocardial infarction, except alcohol, which had a weaker association ($p = 0.03$). After multivariate analysis, current smoking and raised ApoB/ApoA1 ratio (top *vs.* lowest quintile) were the two strongest risk factors, followed by history of diabetes, hypertension, and psychosocial factors. Body-mass index was related to risk of myocardial infarction, but this relation was weaker than that of abdominal obesity (waist/hip ratio).”

IV. ANGINAL CHEST PAIN AND IMPOTENCE

A. Anginal Pain

In conditions such as angina, where oxygen supply to the heart muscle is low, the frequency and severity of chest pain may be increased by cigarettes. Nicotine causes a slight increase in blood pressure and heart rate. Therefore, the

heart muscle demands more oxygen. Thus, the combination of carbon monoxide and nicotine increases the bad effects. Patients with angina who are smokers develop chest pain at lower levels of exercise. See chapter entitled Angina.

Other components of cigarette smoking include a glycoprotein that is highly allergenic and may cause shortness of breath, asthmatic attacks, or eye irritation. In addition, the glycoprotein is believed to cause damage to the lining of arteries and an increase in atherosclerosis.

B. Impotence

Smoking causes endothelial dysfunction and appears to cause a constriction of small penile arteries implicated as one of the many factors responsible for impotence in some individuals. Endothelial dysfunction is common to the pathophysiology of both erectile dysfunction and coronary artery disease events.

V. HABITUATION AND CESSATION

A. Habituation

Habituation is a major problem because nicotine is a potent chemical that has been conclusively shown to produce “addiction” and dependence. The smoker will go to extremes to purchase his or her cigarettes and ensure that they are readily available.

B. How to Stop

1. Motivation

Motivation is the key but this is difficult to sustain. Most individuals recognize that nicotine has addicting potential but this does not alter thinking of young individuals age 10–18 of those under stress who require the effects of smoking a cigarette. More important, perhaps motivation may be derived from the following thought:

- Carbon monoxide in cigarette smoke is potentially as dangerous as carbon monoxide in a home with a defective furnace or the fumes from a running motor car engine in a closed garage.

2. Strategies

- Craving and hunger can be satisfied by smoking a cigarette or by chewing nicotine-containing gum, wearing a nicotine patch, or use of a tablet.

- Participation in stop-smoking clinics and other groups that emphasize educational and behavioral modification; hypnosis for selected individuals.
- Help health programs: American Cancer Society “I quit kit”. National Cancer Institute: “Helping smokers quit”.

Note that some heavy smokers who stop *cold turkey* do not get symptoms of withdrawal.

C. Effect of Cessation

Rosenberg *et al.* indicated that cessation of smoking significantly reduces cardiovascular risk over a 1- to 3-year period with an exponential decline approaching the risk in ex-smokers within 5 years of cessation. Reportedly, Seargent *et al.* indicate that a citywide smoking ban in public places over a 6-month period in Helena, Montana, reduced the incidence of acute MI by 60% during that time period.

There is no doubt that smoking causes chronic bronchitis and emphysema which leads to cor pulmonale, heart failure due to lung disease; this debilitating disease can be arrested by cessation of smoking.

BIBLIOGRAPHY

- Adams, M. R., Jessup, W., and Celermajer, D. S. Cigarette smoking is associated with increased human monocyte adhesion to endothelial cells: Reversibility with oral L-arginine but not vitamin C. *J. Am. Coll. Cardiol.*, 29:491–497, 1997.
- Ambrose, J. A., and Barua R. S. The pathophysiology of cigarette smoking and cardiovascular disease: An update. *J. Am. Coll. Cardiol.*, 43:1731–37, 2004.
- Barua, R. S., Ambrose, J. A., Eales-Reynolds, L. J., DeVoe, M. C., Zervas, J. G., and Saha, D. C. Dysfunctional endothelial nitric oxide biosynthesis in healthy smokers with impaired endothelium-dependent vasodilatation. *Circulation*, 104:1905–1910, 2001.
- Barua, R. S., Ambrose, J. A., Srivastava, S., DeVoe, M. C., and Eales-Reynolds, L. J. Reactive oxygen species are involved in smoking-induced dysfunction of nitric oxide biosynthesis and upregulation of endothelial nitric oxide synthase: An in vitro demonstration in human coronary artery endothelial cells. *Circulation*, 107:2342–2347, 2003.
- Burke, A. P., Farb, A., Malcom, G. T., Liang, Y. H., Smialek, J., and Virmani, R. Coronary risk factors and plaque morphology in men with coronary disease who died suddenly. *N. Engl. J. Med.*, 336:1276–1282, 1997.
- Burke, A. P., Farb, A., Malcom, G. T., Liang, Y., Smialek, J., and Virmani, R. Effect of risk factors on the mechanism of acute thrombosis and sudden coronary death in women. *Circulation*, 97:2110–2116, 1998.
- Celermajer, D. S., Sorensen, K. E., and Georgakopoulos, D. et al. Cigarette smoking is associated with dose-related and potentially reversible impairment of endothelium-dependent dilation in healthy young adults. *Circulation*, 88:2149–2155, MEDLINE, .1993.

- Celermajer, D. S., Adams, M. R., Clarkson, P. et al. Passive smoking and impaired endothelium-dependent arterial dilatation in healthy young adults. *N. Engl. J. Med.*, 334:150–154, MEDLINE, 1996.
- Craig, W. Y., Palomaki, G. E., and Haddow, J. E. Cigarette smoking and serum lipid and lipoprotein concentrations: An analysis of published data. *BMJ*, 298:784–788, 1989.
- Czernin, J., Sun, K., Brunken, R., Bottcher, M., Phelps, M., and Schelbert, H. Effect of acute and long-term smoking on myocardial blood flow and flow reserve. *Circulation*, 91:2891–2897, 1995.
- Frei, B., Forte, T. M., Ames, B. N., and Cross, C. E. Gas phase oxidants of cigarette smoke induce lipid peroxidation and changes in lipoprotein properties in human blood plasma: Protective effects of ascorbic acid. *Biochem. J.*, 277:133–138, 1991.
- Hedblad, B., Ögre, M., Engström, G. et al. Heterogeneity of cardiovascular risk among smokers is related to degree of carbon monoxide exposure. *Atherosclerosis*, 179:177–183, 2005.
- Heitzer, T., Yla-Herttuala, S., Luoma, J. et al. Cigarette smoking potentiates endothelial dysfunction of forearm resistance vessels in patients with hypercholesterolemia: Role of oxidized LDL. *Circulation*, 9:1346–1353, 1996.
- Ijzerman, R. G., Serne E. H., van Weissenbruch M. M., van Weissenbruch M. M., de Jongh R. T., and Stehouwer C. D. Cigarette smoking is associated with an acute impairment of microvascular function in humans. *Clin. Sci. (London)*, 104:247–252, 2003.
- Kugiyama, K., Yasue, H., Ohgushi, M. et al. Deficiency in nitric oxide bioactivity in epicardial coronary arteries of cigarette smokers. *J. Am. Coll. Cardiol.*, 28:1161–1167, MEDLINE, 1996.
- Lightwood, J. M., and Glantz, S. A. Short-term economics and health benefits of smoking cessation: Myocardial infarction and stroke. *Circulation*, 96:1089–1096, 1997.
- Mayhan, W. G., and Sharpe, G. M. Effect of cigarette smoke extract on arteriolar dilatation in vivo. *J. Appl. Physiol.*, 81:1996–2003, 1996.
- Mayhan, W. G., and Patel, K. P. Effect of nicotine on endothelium-dependent arteriolar dilatation in vivo. *Am. J. Physiol.*, 272: H2337–H2342, 1997.
- McVeigh, G. E., Lemay, L., Morgan, D., and Cohn, J. N. Effects of long-term cigarette smoking on endothelium-dependent responses in humans. *Am. J. Cardiol.*, 78:668–672, 1996.
- Morita, H., Ikeda, H., Haramaki, N. et al. Only two-week smoking cessation improves platelet aggregability and intraplatelet redox imbalance of long-term smokers. *J. Am. Coll. Cardiol.*, 45:589–594, 2005.
- Nishio, E., and Watanabe, Y. Cigarette smoke extract inhibits plasma paraoxonase activity by modification of the enzyme's free thiols. *Biochem. Biophys. Res. Commun.*, 236:289–293, 1997.
- Napoli, C., and Ignarro, L. J. Nitric oxide and atherosclerosis. *Nitric Oxide*, 5:88–97, 2001.
- Ota, Y., Kugiyama, K., Sugiyama, S. et al. Impairment of endothelium-dependent relaxation of rabbit aortas by cigarette smoke extract—role of free radicals and attenuation by captopril. *Atherosclerosis*, 131:195–202, 1997.
- Pech-Amsellem, M. A., Myara, I., Storogenko, M., Demuth, K., Proust, A., and Moatti, N. Enhanced modifications of low-density lipoproteins (LDL) by endothelial cells from smokers: A possible mechanism of smoking-related atherosclerosis. *Cardiovasc. Res.*, 31:975–983, 1996.
- Reaven, G., and Tsao, P. S. Insulin resistance and compensatory hyperinsulinemia: The key player between cigarette smoking and cardio-vascular disease. *J. Am. Coll. Cardiol.*, 41:1044–1047, 2003.
- Rival, J., Riddle, J. M., and Stein, P. D. Effects of chronic smoking on platelet function. *Thromb. Res.*, 45:75–85, 1987.
- Rosenberg, L., Kaufman, D. W., Helmrich, S. P., and Shapiro, S. The risk of myocardial infarction after quitting smoking in men under 55 years of age. *N. Engl. J. Med.*, 313:1511–1514, 1985.
- Sugiishi, M., and Takatsu, F. Cigarette smoking is a major risk factor for coronary spasm. *Circulation*, 87:76–79, 1993.
- Sumida, H., Watanabe, H., Kugiyama, K., Ohgushi, M., Matsumura, T. and Yasue, H. Does passive smoking impair endothelium-dependent coronary artery dilation in women?. *J. Am. Coll. Cardiol.*, 31:811–815, MEDLINE, 1998.
- Tracy, R. P., Psaty, B. M., Macy, E. et al. Lifetime smoking exposure affects the association of C-reactive protein with cardiovascular disease risk factors and subclinical disease in healthy elderly subjects. *Arterioscler. Thromb. Vasc. Biol.*, 17:2167–2176, 1997.
- Wang, X. L., Greco, M., Sim, A. S., Duarte, N., Wang, J., and Wilcken, D. E. Effect of CYP1A1 MspI polymorphism on cigarette smoking related coronary artery disease and diabetes. *Atherosclerosis*, 162:391–397, 2002.
- Wang, X. L., Sim, A. S., Wang, M. X., Murrell, G. A., Trudinger, B., and Wang, J. Genotype dependent and cigarette specific effects on endothelial nitric oxide synthase gene expression and enzyme activity. *FEBS. Lett.*, 471:45–50, 2000.
- Wiesmann, F., Petersen, S. E., Leeson, P. M., and Francis, J. M. Global impairment of brachial, carotid, and aortic vascular function in young smokers. Direct quantification by high-resolution magnetic resonance imaging. *J. Am. Coll. Cardiol.*, 44:2056–2064, 2004.
- Yamaguchi, Y., Kagota, S., Haginaka, J., and Kunitomo, M. Evidence of modified LDL in the plasma of hypercholesterolemic WHHL rabbits injected with aqueous extracts of cigarette smoke. *Environ. Toxicol. Pharmacol.*, 8:255–260, 2000.
- Yokode, M., Kita, T., Arai, H. et al. Cholesteryl ester accumulation in macrophages incubated with low density lipoprotein pretreated with cigarette smoke extract. *Proc. Natl. Acad. Sci. USA*, 85:2344–2348, 1988.
- Yusuf, S., Hawken, S., Ôunpuu, S. et al. On behalf of the INTERHEART Study Investigators. Effect of potentially modifiable risk factors associated with myocardial infarction in 52 countries (the INTERHEART study): case-control study. *Lancet*, 364:937–952, 2004.

Electrocardiography

- I. Historical
- II. General Applications
- III. The Normal Electrocardiogram
- IV. Diagnosis of Specific Conditions
- V. Recent Discoveries

GLOSSARY

arrhythmia general term for an irregularity or rapidity of the heartbeat, an abnormal heart rhythm.

hypertrophy increase in thickness of muscle.

ischemia temporary lack of blood and oxygen to an area of cells, for example, the heart muscle, usually due to severe obstruction of the artery supplying blood to this area of cells.

left ventricular dysfunction poor contractility of the ventricle, this leads to heart failure.

myocardial infarction death of an area of heart muscle due to blockage of a coronary artery by blood clot and atheroma; medical term for a heart attack or coronary thrombosis.

myocardium the heart muscle.

pericarditis inflammation of the pericardium or sac surrounding the heart; this is not a heart attack.

I. HISTORICAL

The development of the modern electrocardiographic instrument illustrates how medicine, a branch of the biologic sciences, took advantage of the concepts of physical science and its instrumentation. The invention of the electrocardiographic instrument would not have been possible without the notable orchestrated work of engineers, physicists, physiologists, and researchers. Of particular importance was the development of the string galvanometer by Ader, a French electrical engineer.

Thus, it seems reasonable to give readers the following historical details. The initial work of Galvani (1791), Muller (1856), Waller (1890–1900), and Ader (1897)

initiated Einthoven's discovery from 1901 to 1903. The rather heavy and cumbersome Einthoven machine was too complicated for routine diagnostic use as it occupied two rooms and required five assistants to operate the instrument. Advances that led to the modern electrocardiograph required the perseverance of the Cambridge Scientific Instrument Company and the diligent research work of Sir Thomas Lewis, Frank Wilson, Goldberger, and others.

A. Early Timeline

In about 1760 Luigi Galvani observed that an electrical stimulus applied to a motor nerve caused contraction of the associated muscle. In 1856, Muller, who was working on the dissection of live frogs, observed that when a motor nerve to a frog's leg was laid over the isolated beating heart, the frog's leg kicked with each heartbeat. In 1887, Waller observed that the heart's rhythmic electrical stimuli could be monitored from a person's skin. Waller's initial work in electrocardiography was conducted at St. Mary's Hospital in London. He called the tracing obtained with a Lippmann capillary electrometer an electrogram. The instrument was too large to adopt for clinical use and his recordings prior to 1901 were difficult to understand. Einthoven had attended Waller's first demonstration of the device at St Mary's hospital and would go on to further the technology.

In 1897, Ader, a French engineer, invented the first single-string galvanometer, which suspended a fine metal wire between the poles of a large magnet. This instrument was devised mainly for transmission of telegraphic data at high speed, but without this invention today's electrocardiographic recordings would be impossible.

B. Einthoven

A year after receiving his medical degree, Einthoven was appointed professor of physiology and histology at

Leyden University. Around 1895 Einthoven returned from Waller's lecture and laboratory full of enthusiasm. He became disenchanted with the capillary electrometer, however. He initially experimented with the d'Arsonval galvanometer and assessed the thesis of his tutor, Bosscha, who wrote "The Differential Galvanometer" in 1854. Einthoven finally considered the work of Ader and the importance of the single-string galvanometer. He acknowledged Ader's contribution when he published his landmark paper in 1901.

Einthoven recognized that the heart possessed electrical activity, and he recorded this activity using two sensors attached to two forearms and connected to a silver wire that ran between two poles of a large permanent magnet. He noted that the silver wire moved rhythmically with the heartbeats, but to visualize the small movements Einthoven shone a light beam across the wire and the wavy movements of the wire were recorded on moving photographic paper. Einthoven recorded the waves and spiky deflection, and labeled the first smooth rounded wave, P, the spiky deflection QRS, and the last recorded deflection he named T wave (Fig. 1). The choice of this

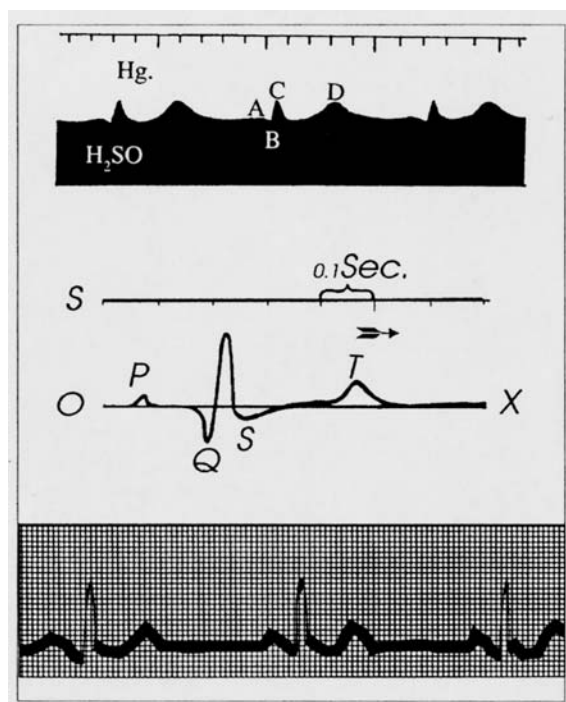

FIGURE 1 Demonstration of perfect agreement between the record obtained with Einthoven's modified galvanometer and the mathematically corrected curves obtained with the capillary electrometer. (Photo source: University of Central Florida. Literary source: Fleckenstein, K. (1984). The early ECG in medical practice. *Medical Instrumentation*. Vol. 18, no. 3, May-June. With permission from Association for the Advancement of Medical Instrumentation, 1901 N. Ft. Meyer Drive, Ste 602, Arlington, Virginia, 22209.)

lettering obeyed the convention used by geometers: curved lines were labeled beginning with P and points on straight lines were labeled beginning with Q. Einthoven's paper in German on the galvanometric registration of the human "elektrokardiogramm" (EKG) was published in 1903. Because of the German publication, the abbreviation EKG was used until post World War II, when in America the currently used ECG was adopted. It is relevant to note that Waller finally abandoned the capillary electrometer and used Einthoven's string galvanometer from 1910 to 1917.

In addition, Fig. 1 shows the tracing obtained with the capillary electrometer and Einthoven's corrected curve. The upper and middle records were shown in his paper on the galvanometric registration of the human elektrokardiogramm published in 1903.

C. Sir Thomas Lewis

In 1911 Sir Thomas Lewis, Einthoven, and others correlated the ECG waves with the contracting heart and noted that the P wave was related to the contraction of the atrium and that the QRS spiky deflection was associated with ventricular contraction.

The Cambridge Scientific Instrument Company made improvements in the size and capabilities and brought out a table model in 1911, one of which was leased to Lewis at the London Hospital. In 1917 Herrick reported the first case in which the electrocardiogram was diagnostic of myocardial infarction. In 1926 a fully portable instrument was marketed.

From 1934 to 1946 improvements in the quality of recordings were due to the immense work and technique of Frank Wilson at the University of Michigan. He had studied with Lewis and had purchased one of the early electrocardiograph machines manufactured by the Cambridge Scientific Instrument Company in 1914. Wilson's work led to the introduction of the central terminal, the V leads applied to the chest wall, and the leads applied to the limbs which improved the quality of recordings. Goldberger, in 1942, introduced a technique of obtaining augmented unipolar extremity leads, labeled aVR, aVL, and aVF. This allowed a large amplitude deflection to be recorded.

II. GENERAL APPLICATIONS

Despite the advent of expensive and sophisticated cardiologic tests, the electrocardiogram remains the most reliable tool for the confirmation of acute myocardial infarction.

The electrocardiogram — not the cardiac enzymes, troponins, CK–MB, echocardiogram, or Sector PET scan — dictates the rapid administration of lifesaving thrombolytic therapy. There is no test to rival the electrocardiogram in the diagnosis of arrhythmia, which is a common problem seen in clinical practice. Also, the diagnosis of acute pericarditis can only be confirmed by electrocardiographic findings. The very common condition of myocardial ischemia which causes chest pain in patients with angina can be confirmed in some by electrocardiographic findings at rest and particularly during exercise.

III. THE NORMAL ELECTROCARDIOGRAM

The electrocardiogram picks up the heart’s electrical impulses transmitted through the skin of the chest. Figure 2 gives a simplified concept of ion exchange — the polarized, depolarized, and repolarized state of the myocardial cell; and the action potential. An electrical current arriving at the cell causes positively charged ions to cross the cell membrane (depolarization), followed by repolarization which generates an action

potential: phase 0, 1, 2, 3, and 4. This electrical event traverses the heart and initiates mechanical systole or a heartbeat.

Figure 3 gives a diagrammatic representation of the electrocardiogram and its relationship to the potassium and sodium exchange across the cardiac cell membrane with the generation of an action potential. The heart is initially activated by an infinitesimal current generated by the sinoatrial (SA) node, a natural pacemaker. The current of activation spreads radially from the SA node across the atria to the atrioventricular (AV) node and down the bundle branches to the ventricular muscle and Purkinje network (see Fig. 4). The SA node tracing shows no steady resting potential and is characterized by spontaneous depolarization. Figure 5 shows a normal ECG tracing.

IV. DIAGNOSIS OF SPECIFIC CONDITIONS

A. Acute Myocardial Infarction

The ECG diagnosis of acute myocardial infarction is revealed by an elevation of the ST segment in the

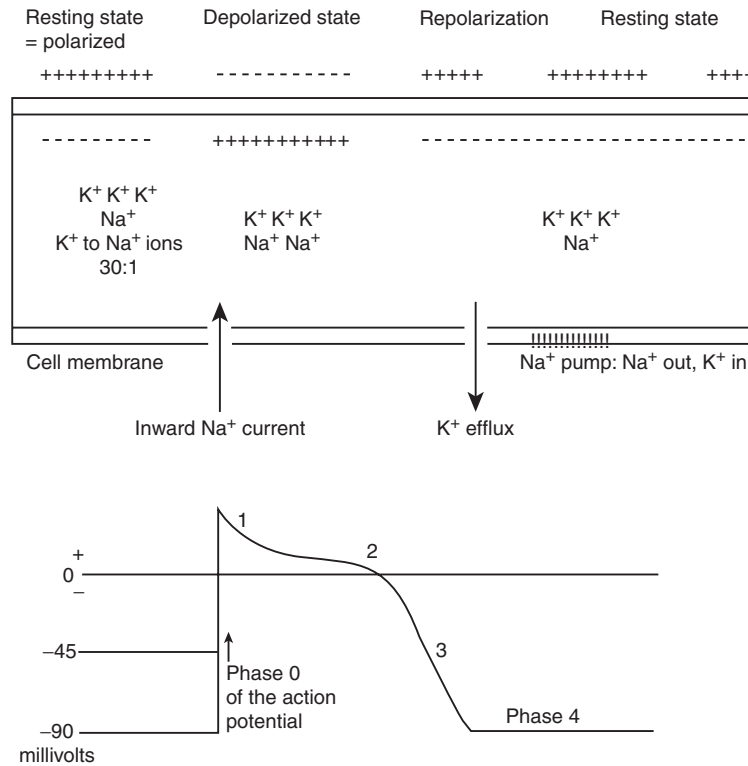

FIGURE 2 A simplified concept of ionic exchange; the polarized, depolarized, and repolarized state of myocardial cell; and the action potential. An electrical current arriving at the cell causes positively charged ions to cross the cell membrane, which causes depolarization, followed by repolarization, which generates an action potential: phases 0, 1, 2, 3, and 4. This electrical event traverses the heart and initiates mechanical systole, or the heart beat. (From Khan, M. Gabriel, *Rapid ECG Interpretation*, second edition, Philadelphia: Elsevier, 2003.)

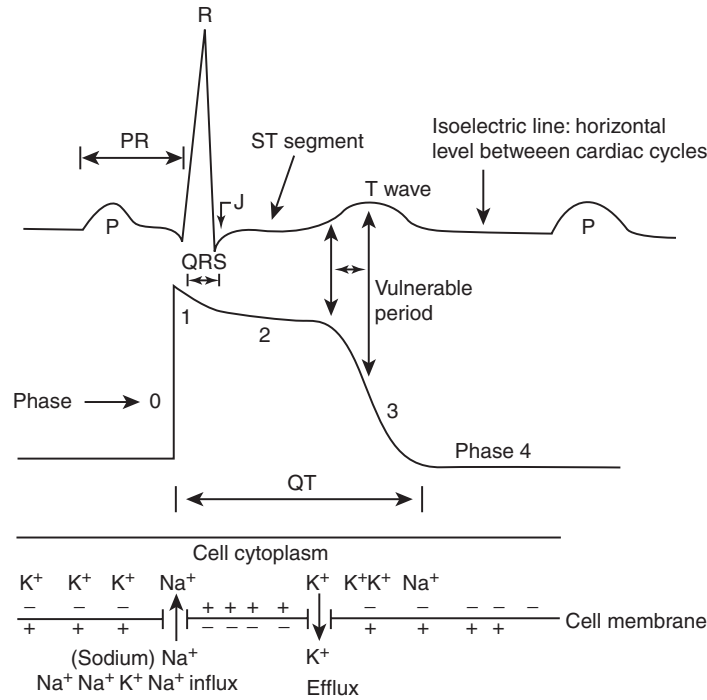

FIGURE 3 Sodium influx, potassium efflux, the action potential, and electrocardiogram. (From Khan, M. Gabriel (2003). *Rapid ECG Interpretation*, 2nd ed., Philadelphia: W.B. Saunders.)

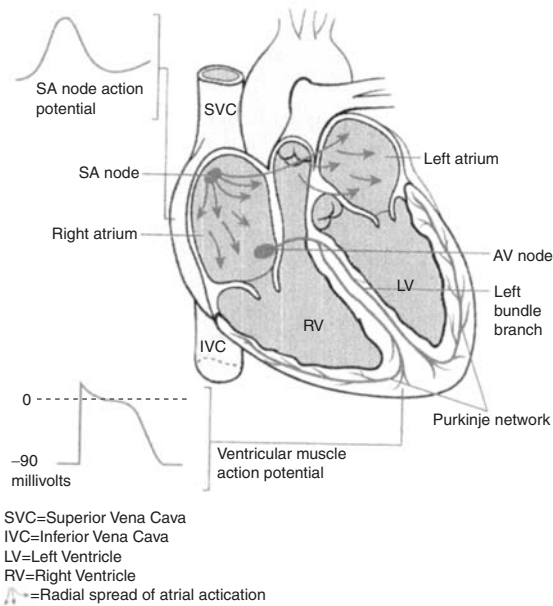

FIGURE 4 Electrical activation of the heart by the sinoatrial (SA) node. The current of activation (arrows) spreads radially from the SA node across the atria to the atrio-ventricular (AV) node and down the bundle branches to the ventricular muscle and Purkinje network. The SA node tracing shows no steady resting potential and is characterized by spontaneous depolarization. (From Khan, M. Gabriel (2003). *Rapid ECG Interpretation*, 2nd ed., Philadelphia: W.B. Saunders.)

patient who has acute chest pain. Figure 6 shows the ECG of a patient with infarction of the anterior wall of the heart. The typical diagnostic ECG finding is ST-segment elevation in the leads taken over the chest, precordial leads V1 through V6 (ST-segment elevation myocardial infarction). Figure 7 shows involvement of the inferior myocardium during inferior myocardial infarction.

Based on this simple ECG finding, physicians, nurses, or paramedics can commence two chewable aspirin, a beta-blocking drug, and intravenous thrombolytic therapy that can save the life of greater than 33% of heart attack victims if this therapy is given within the first hour of onset of symptoms. If treatment is delayed for more than 4 h approximately 15% of lives would be saved, and after 6 h benefit is negligible. Most important, based on the results of two ECGs done 15–30 minutes apart diagnosis is usually sufficiently conclusive to allow such patients to proceed to a catheter laboratory to have coronary angiogram to visualize the blockage of the coronary artery. This is followed by balloon angioplasty and stent implantation that could be life-saving.

In patients with chest pain only, ECG findings differentiate patients into two large population groups: ST-segment elevation myocardial infarction and

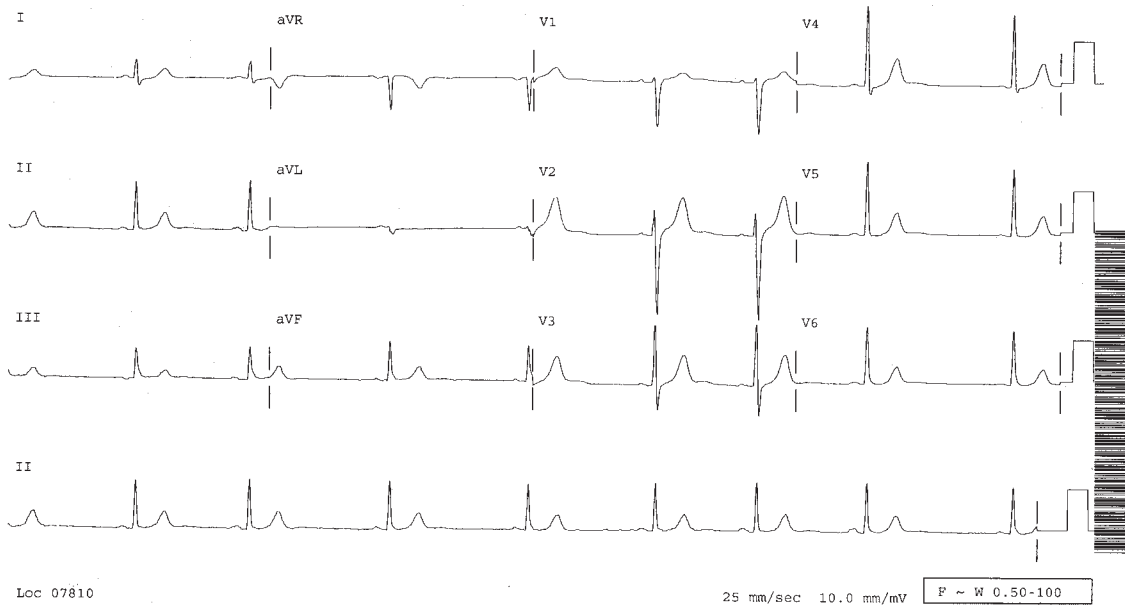

FIGURE 5 Normal electrocardiogram.

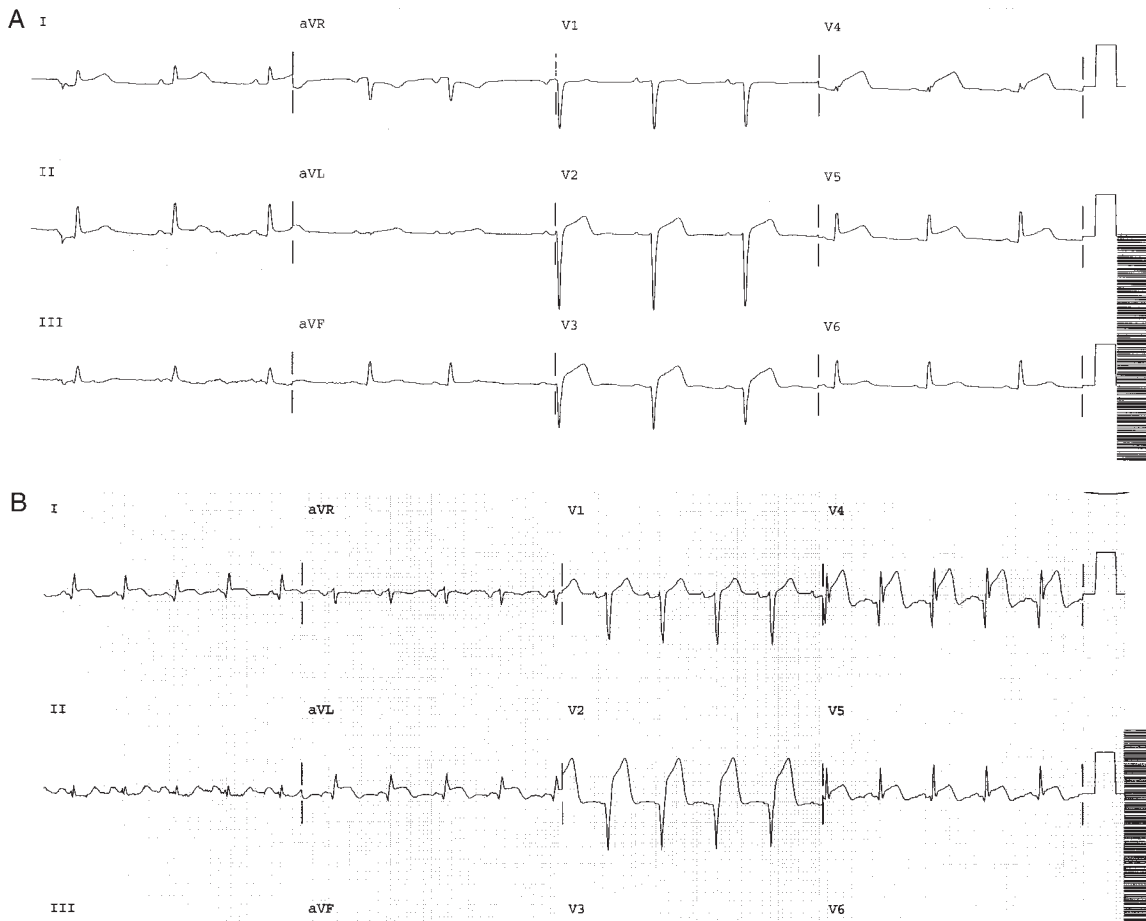

FIGURE 6 ST segment elevation in V1 through V6; pathological Q-waves in leads V1 to V5; indicate acute anterior myocardial infarction.

non-ST-segment elevation myocardial infarction (non-Q-wave infarction; see Fig. 8). The treatment strategies for these two groups are very different (see the chapter Heart Attacks).

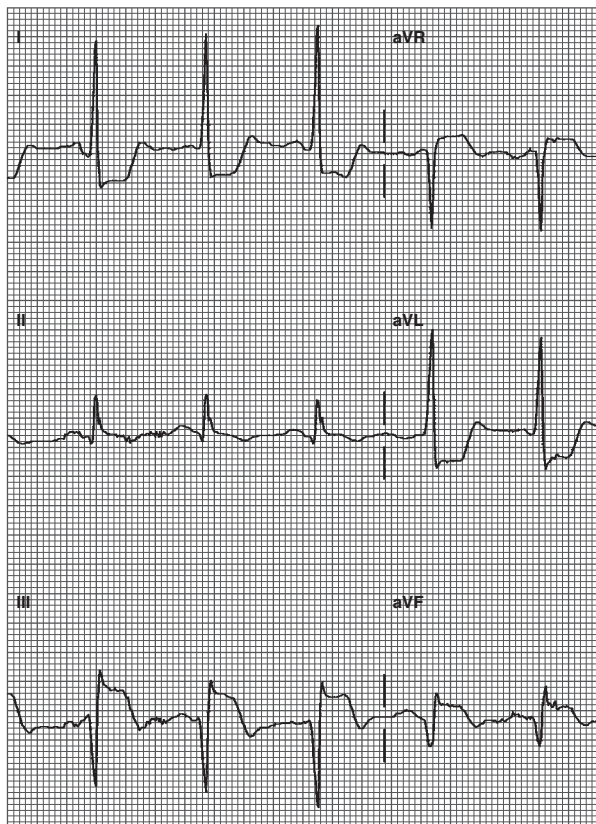

FIGURE 7 Deep pathologic Q waves in II, III, and aVF with marked ST segment elevation; acute inferior MI.

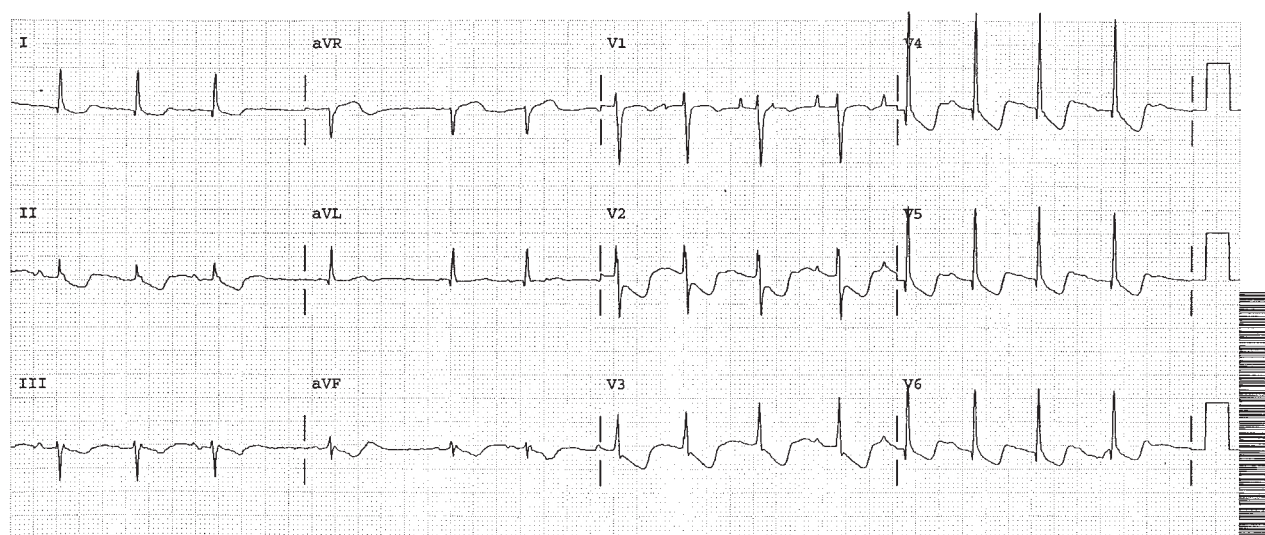

FIGURE 8 Marked ST segment depression in leads V2 to V6: indicate non-ST segment elevation myocardial infarction (non-Q-wave MI).

B. Hypertrophy of the Heart

Enlargement of the heart, particularly the left ventricle muscle, is readily detected by ECG. Also patients with hypertrophied hearts caused by hypertrophic cardiomyopathy usually have abnormal ECGs.

C. Electrical Conduction Defects

The electrical current that traverses the atrium and reaches the ventricle via specialized electrical conducting cables may be delayed because of disease in the conducting cables. The branching of cables that supply the right and left ventricle (Fig. 4) may show signs of an electrical conduction block called right or left bundle branch block. The spiky deflection in the QRS deflection is widened beyond 0.12 seconds. Figure 9A and Figure 9B show the electrocardiographic manifestations of the right bundle branch block. Figure 10A and Figure 10B, shows manifestations of the left bundle branch block. Figure 10B reveals two abnormalities, a left bundle branch block and a large deformed P wave in lead I, which indicates left atrial abnormality. This ECG finding is of importance because it is a clue to the presence of hypertrophy or enlargement of the left atrium and an increase in the left atrial volume or pressure. These clues point to several underlying disease states such as left ventricular strain caused by hypertension, left ventricular dysfunction, congestive heart failure, cardiomyopathy, and valvular heart disease. This shows that a simple ECG tracing reveals a considerable amount of information about specific heart abnormalities.

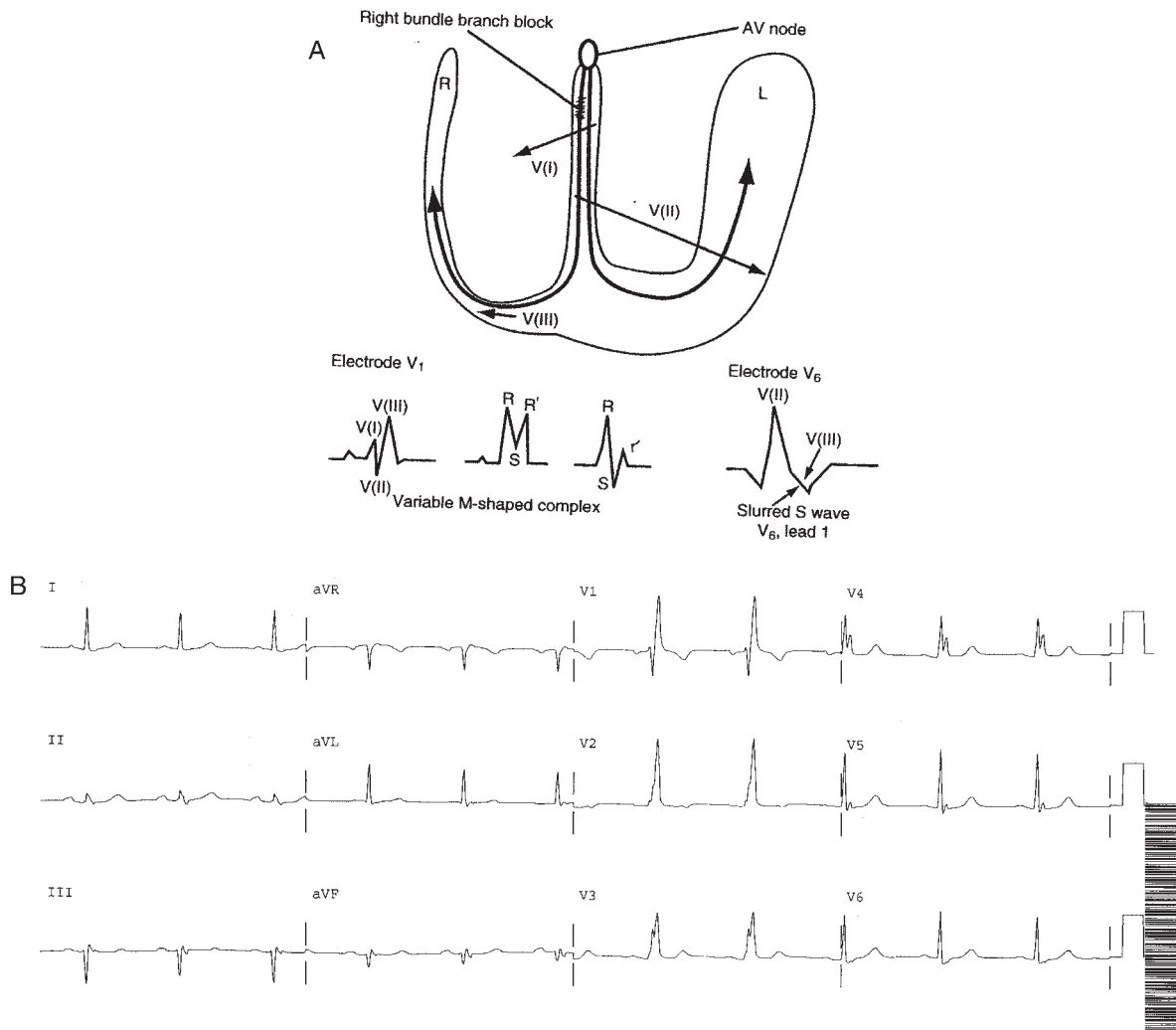

FIGURE 9 A. Genesis of the QRS complex in right bundle branch block. (From Khan, M. Gabriel (2003). *Rapid ECG Interpretation, 2nd ed.*, Philadelphia: W.B. Saunders.) B. ECG shows an rsR pattern in V1 and V2 with a slurred S wave in V6: features of right bundle branch block.

D. Arrhythmia

The most common arrhythmia observed in clinical practice is atrial fibrillation. In this condition the atrium fibrillates but does not contract; thus, the P waves are absent. The atria beat at approximately 300–500 beats per minute. Because of a block in the AV node that separates the atrial current from that in the ventricle, the ventricles beat slower at 100–200 beats per minute. This condition is usually not life-threatening and is easily controlled with drugs such as digoxin or a beta-blocking drug that reduces the ventricular rate and thus the heart rate to less than 100 beats per minute.

Figure 11 shows a tracing from a patient with atrial fibrillation in whom the ventricular rate is rapid at 210 beats per minute. The rapid ventricular rate causes extra

work for the left ventricle which requires more oxygen. Heart failure may precipitate in patients with disorders such as mitral stenosis and many diseases that cause left ventricle dysfunction. In addition, with atrial fibrillation the left atrium does not contract but quivers; this leads to thrombi formation that attaches to the left atrial wall. These clots may break off and are swept away (embolized) in the bloodstream and may block arteries in the brain causing stroke. Embolism may also occur in the kidney and leg vessels causing gangrene. Atrial fibrillation can only be diagnosed by the ECG.

Figure 12 shows the ECG tracing of a patient with atrial fibrillation in whom the fast ventricular rate has been reduced to 105 beats per minute by a beta-adrenergic blocking drug. (For other arrhythmias, see the chapter Arrhythmias/Palpitations).

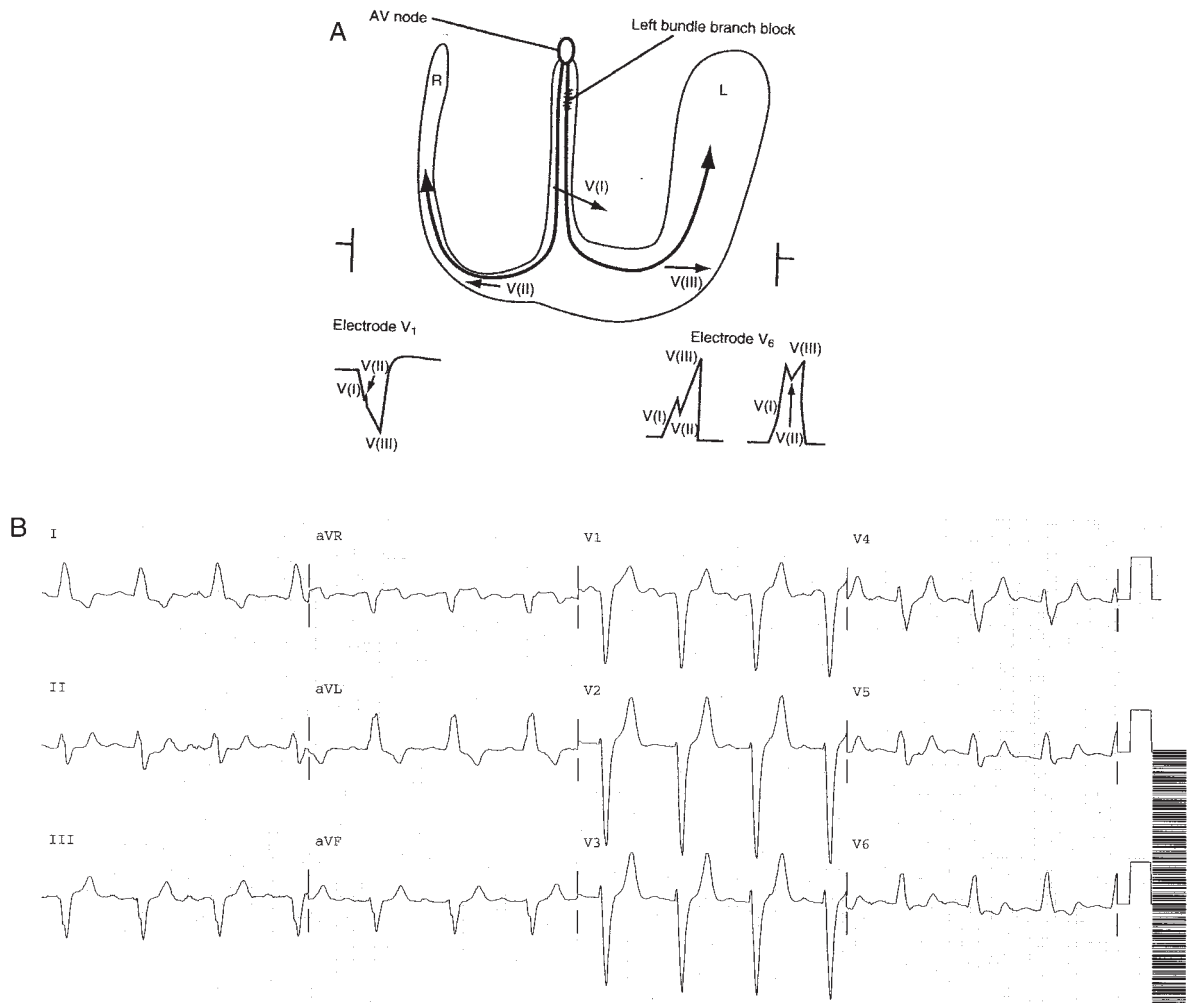

FIGURE 10 A. The contribution of vectors I, II, and III, labeled V(I), V(II), and V(III) to the genesis of left bundle branch block. (From Khan, M. Gabriel (2003). *Rapid ECG Interpretation*, 2nd ed., Philadelphia: W.B. Saunders.)

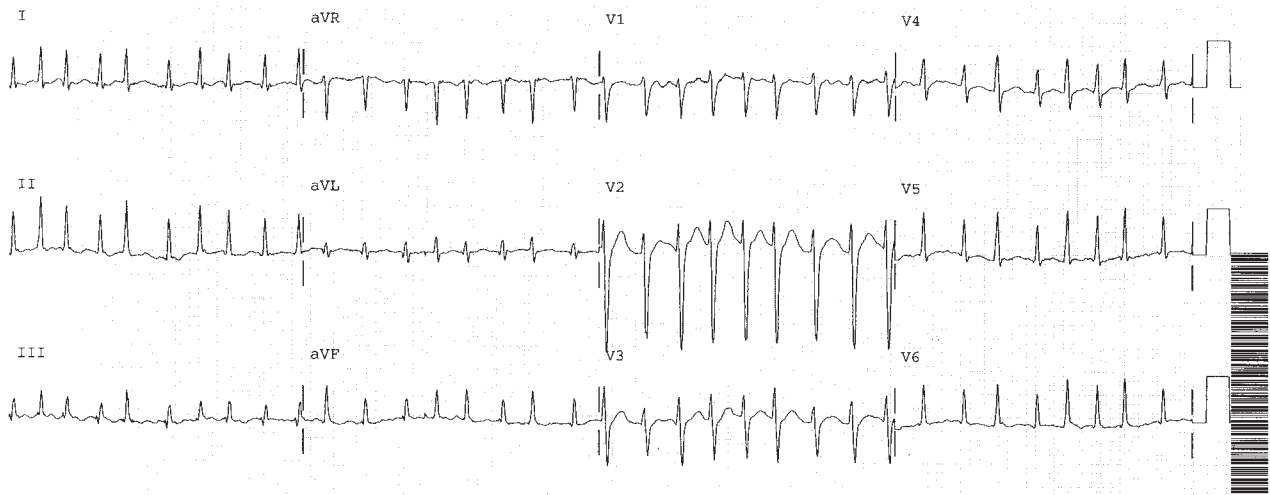

FIGURE 11 ECG shows atrial fibrillation with an uncontrolled ventricular rate of 210 beats per minute.

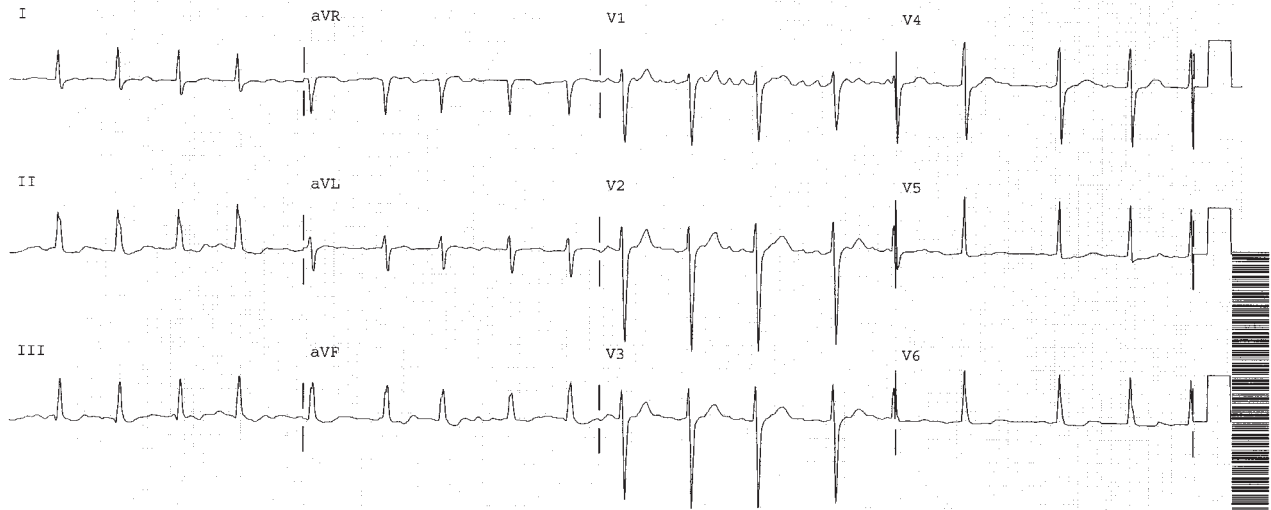

FIGURE 12 ECG shows atrial fibrillation with a controlled ventricular rate of 105 beats per minute.

Figure 15 shows features of WPW syndrome: Delta wave in leads II, III, aVF and V1 to V5. Note the short PR interval <0.10 seconds. Figure 14 shows ventricular premature beats: runs of two (couplets) and run of 5 beats = nonsustained ventricular tachycardia.

V. RECENT DISCOVERIES

A. Microvolt T-wave Alternans

Cambridge Heart, Inc. has provided an interesting instrument that measures T-wave alternans. This test measures extremely subtle beat-to-beat fluctuations in a person's heartbeat called T-wave alternans. These tiny heartbeat variations are measured at one millionth of a volt.

B. Clinical Study: NIH Study

This study was undertaken to determine the value of microvolt T-wave alternans testing.

Study question: T-wave alternans would be associated with increased risk of arrhythmic events in patients with left ventricular dysfunction; the association would be independent of the etiology of congestive heart failure (ischemic vs. nonischemic).

Method: The study enrolled 590 patients with congestive heart failure who had an ejection fraction of less than 40% and had no prior history of arrhythmia. Patients were excluded if they had arrhythmia, particularly atrial fibrillation or flutter, unstable coronary artery disease, and heart failure New York Heart Association class IV.

Results: T-wave alternans was a strong predictor of mortality in patients with left ventricular dysfunction independent of ejection fraction and etiology. In this study 34% of the patients tested negative and 66% positive or indeterminate. Patients with a negative T-wave alternans had an extremely low degree of mortality rate, 1%; patients with a negative T-wave alternans had an extremely low 2-year mortality rate (1%). Figure 13 shows sustained alternans with onset of less than 110 beats per minute. This is consistent with a positive tracing.

Patients who tested positive for T-wave alternans were approximately 10 times more likely to have a cardiac arrest or to become a victim of sudden cardiac death than patients with a negative test. In the MADIT II clinical trial, T-wave alternans positive patients had a 15% mortality versus 7% for the entire MADIT II subgroup. There were no deaths among T-wave alternans negative patients. This study suggests that T-wave alternans positive patients will obtain a greater mortality benefit from an implantable converter defibrillator.

BIBLIOGRAPHY

- Bloomfield, D. M., Steinman, R. C., Namerow, P. B. et al. Microvolt T-wave alternans distinguishes between patients likely and patients not likely to benefit from implanted cardiac defibrillator therapy. A solution to the multicenter automatic defibrillator implantation trial (MADIT)II conundrum. *Circulation*, 110:1885-1889, 2004.
- Khan, M. Gabriel. *Rapid ECG Interpretation*, second edition. W. B. Saunders, Philadelphia, 2003.
- Sabatine, M. S., and Antman, E. M. The thrombolysis in myocardial infarction risk score in unstable angina/non-ST-segment elevation myocardial infarction. *J. Am. Coll. Cardiol.*, 41:89-95, 2003.

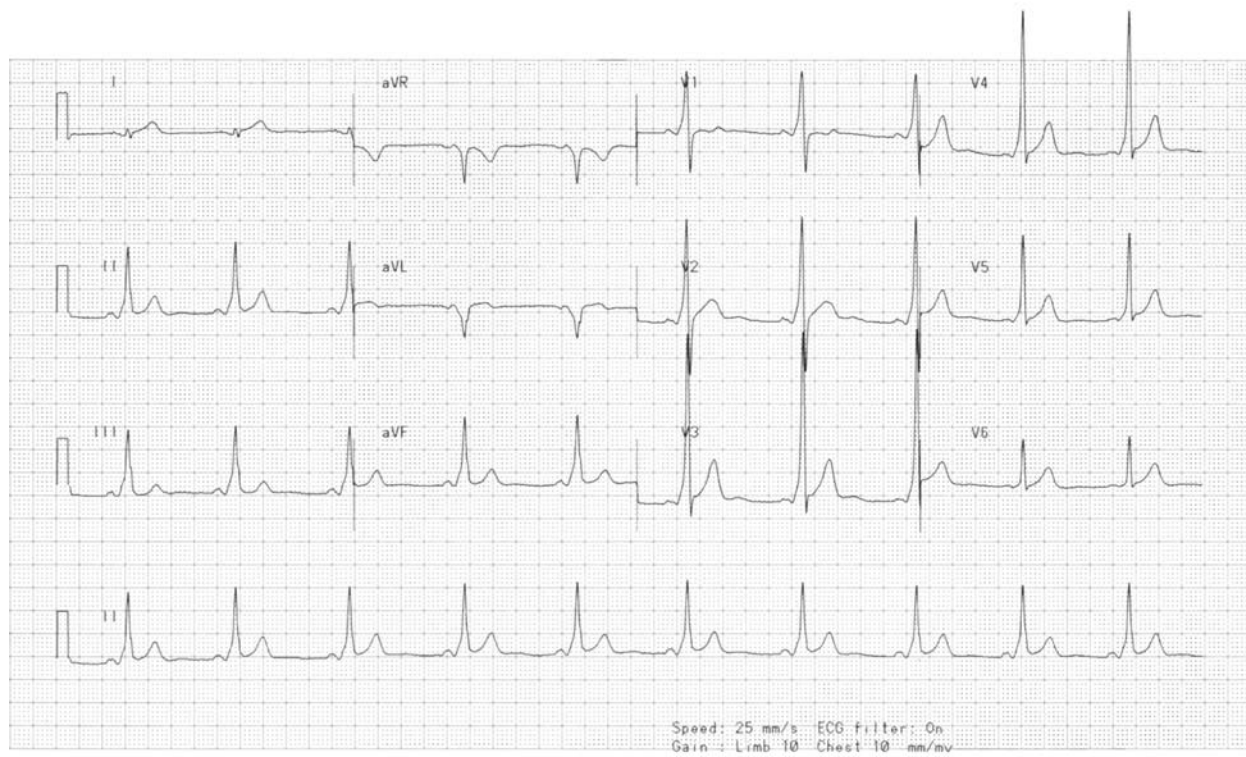

FIGURE 13 Features of WPW syndrome: Delta waves and a short PR interval.

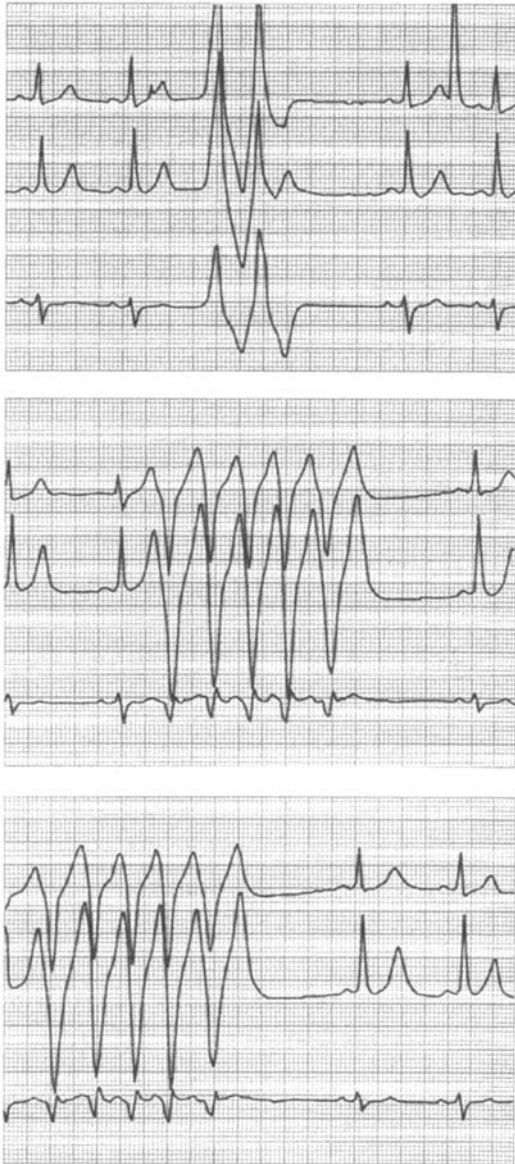
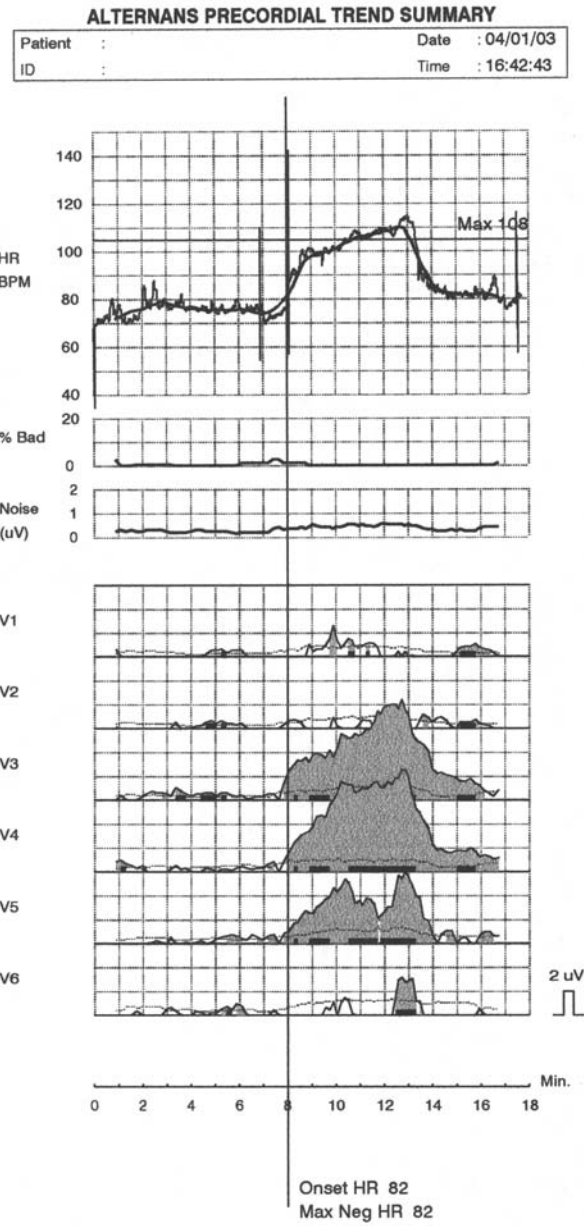

FIGURE 14 Holter monitor showing multifocal ventricular premature beats; couplet, salvos of three, nonsustained ventricular tachycardia. (From Khan, M.G. (2001). *On Call Cardiology, 2nd Ed.*, Philadelphia: W.B. Saunders.)



Preliminary – Physician Must Review

FIGURE 15 Sustained alternans with onset \leq 110 BPM, consistent with positive tracing.

Embryology

I. Development of the Heart

GLOSSARY

- arrhythmia** general term for an irregularity or rapidity of the heartbeat, an abnormal heart rhythm.
- caudal** pertaining to toward the tail or distal end of the body.
- cephalic** pertaining to the head or to the head end of the body.
- blastula** usually spherical body produced by cleavage of a fertilized ovum, consisting of a single layer of cells (blastoderm) surrounding a fluid-filled cavity (blastocoele).
- embryo** developing human from conception until the end of the 8th week by which time all organ systems have been formed.
- ischemic heart disease** atherosclerosis (atheromatous plaques) causes obstruction to coronary arteries depriving the myocardium of blood containing oxygen and necessary nutrients.
- karyotype** chromosomal characteristics of an individual or cell line.
- myocardium** the heart muscle.

IT IS NOT WIDELY KNOWN THAT IN THE HUMAN embryo, the unique little heart begins to beat as early as day 22. Further research in cardiovascular embryology is crucial to the understanding of different cardiac anomalies and the development of therapeutic and preventive strategies.

I. DEVELOPMENT OF THE HEART

Commitment to the cardiogenic cell lineage occurs early in development soon after gastrulation (the embryonic state following the blastula), approximately 48 h following fertilization. The molecular basis for the formation of cardiac myocytes from the presumptive mesoderm requires further elucidation. The mesoderm consists of three germ layers that are incorporated in the building of the tissues and organs of the embryo. Cells committed to the cardiac

lineage are first seen to possess characteristics of cardiac myocytes prior to the formation of the tubular heart.

Within 10–14 days of gestation a pair of mainstem vessels are first differentiated; they are the primitive aortae. This pair of tubes comes to lie parallel and close to each other in the cephalic region of developing body cavity (see Fig. 1). These vessels appear in the splanchnic

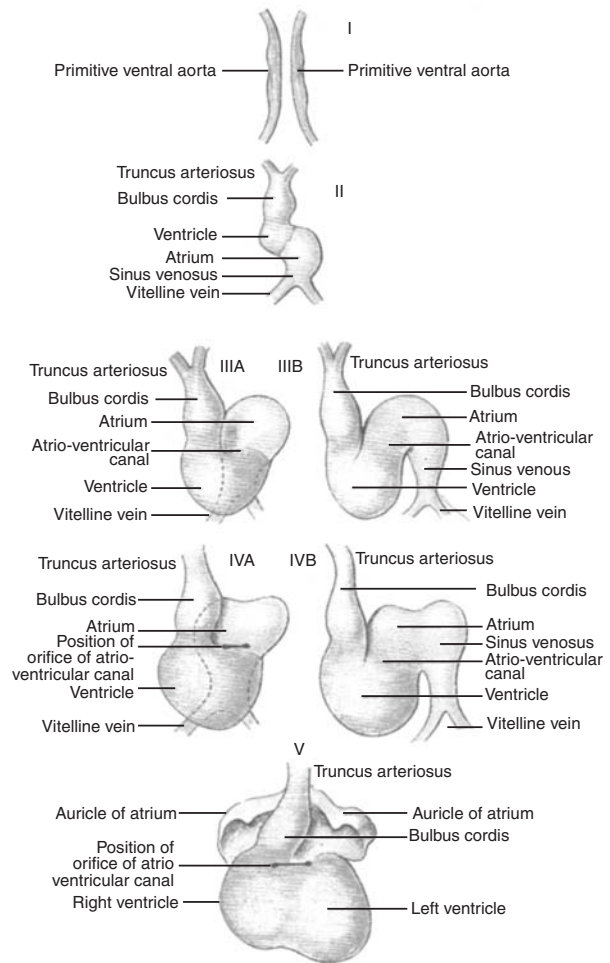

FIGURE 1 Primitive ventral aorta; formation of a tubular heart and subsequent stages of development.

mesoderm of the pericardial region of the embryonic area and extend to the caudal end of the embryo. At the cephalic end the primitive aortae are continuous with another pair of stem vessels called the vitelline veins. Within a few days when the embryo is less than 2.5 mm long, the heart is formed in the septum transversum and the dorsal wall of the pericardium by fusion of the caudal parts of the ventral aortae. A section of main vascular tube specializes and possesses contractile elements within its walls. These walls of the heart tubes consist of a two-cell layer of myocardial cells and an internal single layer of endothelial cells separated from each other by a third layer called cardiac jelly.

In the embryo between 14 to 18 days, precardiac cells are present in a pair of crescent-shaped regions of mesodermal tissue lateral to the primitive streak. Further development involves hyperplasia, proliferation of the myocyte cell pool, and growth in cell size (hypertrophy).

Pacemaker activity begins at an early primitive stage before sinoatrial and atrial tissues have differentiated. By the 21st day, a small region in the left caudal part of the conoventricular tube acts as a pacemaker.

Study of the biophysical differentiation of the heart in the embryo may reveal embryonic cardiac action currents that indicate how sodium and other channels work in the adult. Appreciation of the sodium channels and potassium flux is essential to our understanding of arrhythmias and the cardioactive agents that may show salutary effects without causing harm. Conditions and properties of the cardiac action potential in the embryo resemble those in patients with ischemic heart disease.

In the second month the tubular heart doubles over onto itself to form two parallel pumping systems, each with two chambers and a great artery. The tubular heart now speeds up its development. Figure 1 shows further stages in heart development. The tubular heart is separated

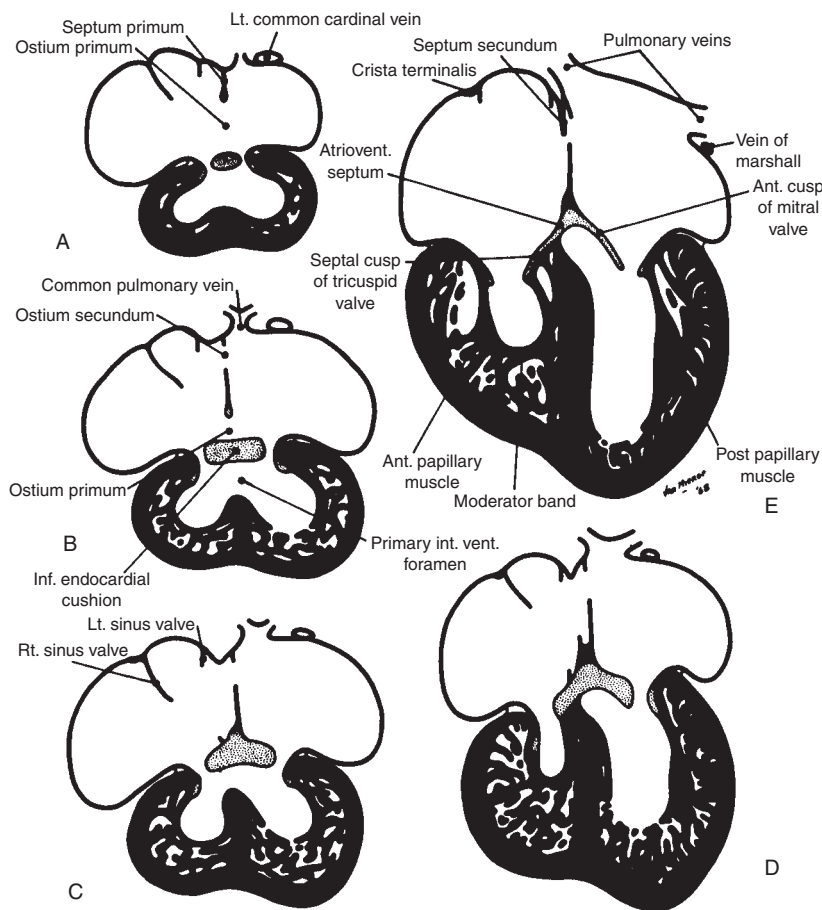

FIGURE 2 Sections through heart of embryos of different ages. Diagrammatic. (A) 6 mm, (B) 9 mm, (C) 12 mm, (D) 17 mm, and (E) 40 mm. (From Van Mierop LHS: Embryology of the atrioventricular canal region, in Feldt RH (ed.) Atrioventricular Canal Defects, W. B. Saunders, Philadelphia, 1976, p. 6.)

by constrictions into six parts named from the caudal to the cephalic end: (1) sinus venosus, (2) atrium, (3) atrio-ventricular canal, (4) ventricle, (5) bulbus cordis, and (6) truncus arteriosus. Two ventral aortae and two dorsal aortae fuse in parts of their extent to form a median descending aorta.

As the heart tube elongates by additional precardiac mesoderm at the caudal end and starts to take on a curved shape, the pacemaker cells move progressively to the caudal-most extremity that remains part of the ventricle. After a few days pacemaker function shifts to the right side, as sinoatrial tissue begins to form. The pacemaker activity, thus, commences at a primitive stage in the development of the embryo before the atrial or sinoatrial tissues have differentiated. The two atria develop from the sinoatrium.

Figure 2 shows sections through the heart of an embryo at different stages of development. The AV canal is divided by the endocardial cushions into tricuspid and mitral orifices, and the right and left ventricle are formed from the primitive ventricle and bulbus cordis. The atrioventricular canal leads into the primitive left ventricle, and blood reaches the primitive right ventricle only through the primary interventricular foramen.

Table 1 shows developmental stages in human embryos. From day 33 to 36 upper limbs are paddle shaped, lens and nasal pits are visible, optic cups are present, lower limb buds have appeared, and most important, the heart prominence is distinct (see Fig. 3).

Several anomalies may result from defects in the basic cardiac developmental pattern. Table 2 gives teratogenic agents in humans. Lithium plays a role in Ebstein's

TABLE I
Developmental Stages in Human Embryos^a

Age (days)	Stage	No. of somites	Length (mm)	Main characteristics
20–21	9	1–3	1.5–3.0	Deep neural groove and first somites present. Head fold evident.
22–23	10	4–12	2.0–3.5	Embryo straight or slightly curved. Neural tube forming or formed opposite somites, but widely open at rostral and caudal neuropores. First and second pairs of branchial arches visible.
24–25	11	13–20	2.5–4.5	Embryo curved due to head and tail folds. Rostral neuropore closing. Otic placodes present. Optic vesicles formed.
26–27	12	21–29	3.0–5.0	Upper limb buds appear. Caudal neuropore closing or closed. Three pairs of branchial arches visible. Heart prominence distinct. Otic pits present.
28–30	13	30–35	4.0–6.0	Embryo has C-shaped curve. Upper limb buds are flipper-like. Four pairs of branchial arches visible. Lower limb buds appear. Otic vesicles present. Lens placodes distinct. Attenuated tail present.
31–32	14	<i>b</i>	5.0–7.0	Upper limbs are paddle-shaped. Lens pits and nasal pits visible. Optic cups present.
33–36	15		7.0–9.0	Hand plates formed. Lens vesicles present. Nasal pits prominent. Lower limbs are paddle-shaped. Cervical sinus visible.
37–40	16		8.0–11.0	Foot plates formed. Pigment visible in retina. Auricular hillocks developing.
41–43	17		11.0–14.0	Digital, or finger, rays appear. Auricular hillocks outline future auricle of external ear. Trunk beginning to straighten. Cerebral vesicles prominent.
44–46	18		13.0–17.0	Digital, or toe, rays appearing. Elbow region visible. Eyelids forming. Notches between finger rays. Nipples visible.
47–48	19		16.0–18.0	Limbs extend ventrally. Trunk elongating and straightening. Midgut herniation prominent.
49–51	20		18.0–22.0	Upper limbs longer and bent at elbows. Fingers distinct but webbed. Notches between toe rays. Scalp vascular plexus appears.
52–53	21		22.0–24.0	Hands and feet approach each other. Fingers are free and longer. Toes distinct but wedged. Stubby tail present.
54–55	22		23.0–28.0	Toes free and longer. Eyelids and auricles of external ears are more developed.
56	23		27.0–31.0	Head more rounded and shows human characteristics. External genitalia still have sexless appearance. Distinct bulge caused by herniation of intestines still present in umbilical cord. Tail has disappeared.

^aModified, with permission, from K. L. Moore (1982). Criteria for estimating developmental stages in human embryo. In "The Developing Human: Clinically Oriented Embryology," 4th Ed. Saunders, Philadelphia.

^bAt this and subsequent stages, the number of somites is difficult to determine and therefore is not a useful criterion.

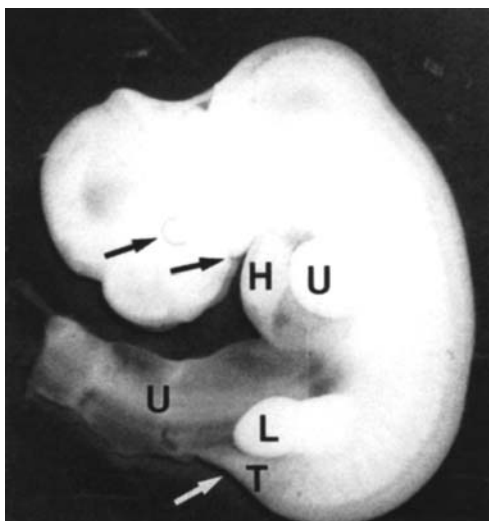

FIGURE 3 Well-developed embryo at stage 15, length 7 mm, showing developing eye (arrow), mouth (arrow), heart (h), upper limb (U), and lower limb (L). The presence of tail (T) is a normal finding at this stage. Umbilical cord (u) contains three vessels. (From *Encyclopedia of Human Biology*, 1997.)

TABLE 2
Teratogenic Agents in Humans

Radiation

- Atomic weapons
- Radioiodine
- Therapeutic

Infections

- Cytomegalovirus
- Herpes virus hominis I and II
- Parvovirus B-19 (*Erythema infectiosum*)
- Rubella virus
- Syphilis
- Toxoplasmosis
- Venezuelan equine encephalitis virus

Maternal metabolic imbalance

- Alcoholism
- Diabetes
- Endemic cretinism
- Folic acid deficiency (including following gastric bypass surgery)
- Hyperthermia
- Phenylketonuria
- Rheumatic disease and Sjögren's syndrome (congenital heart block)
- Virilizing tumors
- Chorionic villus sampling, early before the 60th day

Drugs and environmental chemicals

- 13-*cis* Retinoic acid (isotretinoin and accutane)
- Aminopterin and methylaminopterin

(continued)

TABLE 2

Continued

- Androgenic hormones
- Busulfan
- Chlorobiphenyls
- Cocaine
- Coumarin anticoagulants
- Cyclophosphamide
- Diethylstilbestrol
- Diphenylhydantoin
- Enalapril (and other ACE inhibitors)
- Etretinate
- Iodides and goiter
- Lithium
- Mercury, organic
- Methimazole and scalp defects
- Methylene blue via intraamniotic injection
- Misoprostol
- Penicillamien
- Tetracyclines
- Thalidomide
- Trimethadione
- Valproic acid

Possible teratogens

- ?Binge drinking
- ?Carbamazepine
- ?Cigarette smoking
- ?Disulfiram
- ?Fluconazole, high dose
- ?High vitamin A
- ?Lead
- ?Primidone
- ?Streptomycin
- ?Toluene abuse
- ?Varicella virus
- ?Zinc deficiency

Unlikely

- Agent Orange
- Anesthetics
- Aspartame
- Aspirin (but aspirin in the second half of pregnancy may increase cerebral hemorrhage during delivery)
- Bendectin (antinauseants)
- Birth control pills
- Illicit drugs (marihuana, LSD)
- Metronidazole
- Progesterone (hydroxyprogesterone and medroxyprogesterone)
- Rubella vaccine
- Spermicides
- Ultrasound
- Video display screens

anomaly and tricuspid atresia. Dilantin is known to cause pulmonary stenosis, aortic stenosis, coarctation, and patent ductus arteriosus. Rubella is a known cause of patent ductus arteriosus, atrial septal defects, and ventricular septal defects as well as other anomalies.

During the past decade workers have identified several myogenic determination genes and factors involved in the regulation of muscle gene expression. Gene regulation in the heart is still poorly understood and fruitful research is on the horizon. A single gene mutation is causative in the familial forms of atrial septal defect, mitral valve prolapse, ventricular septal defect, situs inversus, Noonan

syndrome, Holt-Oram syndrome, and Marfan syndrome as well as other anomalies.

BIBLIOGRAPHY

- Friedman, W. F., and Silverman, N. Congenital heart disease in infancy and childhood. In *Heart Disease*, sixth edition. E. Braunwald, D. P. Zipes, and P. Libby, eds. W. B. Saunders, Philadelphia, 2001.
- Kalousek, D. K., and Hendson, G. Embryofetopathology. In *Encyclopedia of Human Biology*, second edition, Academic Press, San Diego, 1997, p. 605.
- Shepard, T. H. Teratology. In *Encyclopedia of Human Biology*, second edition, Academic Press, San Diego, p. 253, 1997.

Endocarditis

- I. Definition and Sites of Infection
- II. Diagnosis
- III. Therapy
- IV. Prevention

GLOSSARY

endocarditis infection of the endocardial lining of heart valves.

endocardium the interior lining of the heart (see the chapter. Anatomy of the Heart and Circulation).

nosocomial pertaining to or originating in a hospital.

I. DEFINITION AND SITES OF INFECTION

Valves previously affected by rheumatic fever and other valve diseases are thick, rough, and swollen. Bacteria that gain entry into the bloodstream on their way through the heart may attach to the roughened valve surface and set up an area of infection. This bacteria may grow to form an “abscess” on the valve. The abscess resembles a clump of moss that swings and sways on the valve leaflet as it opens and closes.

Infection of the heart valves is called infective or bacterial endocarditis. Usually the infection is by bacteria, thus the term bacterial endocarditis, but infections caused by fungi, Coxiella, or chlamydiae can occur, thus the term infective endocarditis is used by many physicians. Infection may involve heart valves not previously known to be abnormal such as a bicuspid aortic valve, mitral valve prolapse, and rarely a septal defect or ventricular aneurysm. Coarctation of the aorta, patent ductus arteriosus, aneurysms, or arteriovenous shunts may be the sites of infective endocarditis. Prosthetic heart valves may be involved and infection at the site of implantation of foreign material may pose a particularly difficult problem.

In susceptible individuals, bacterial endocarditis can begin weeks or months after simple manipulations such

as scaling and cleaning of teeth, other dental work, and surgery in areas of the body where infection may gain access. Patients who have mild heart valve lesions but can normally live a normal life to beyond age 80 may have their lives suddenly shortened by this infection.

Clinicians find it convenient to classify endocarditis in five categories:

1. Endocarditis that involves predominantly left-sided native valves (mitral and aortic) affected by disease, particularly of rheumatic, degenerative, or congenital origin.
2. Prosthetic valve endocarditis.
3. Endocarditis in intravenous drug users: the tricuspid valve is infected in more than 50% of cases, and the aortic in about 25%. More than 75% of patients have no known pre-existing valve lesions. The predominant organism is *Staphylococcus aureus*, but *Pseudomonas* and fungi cause severe valve infections. HIV positive patients may present with unusual organisms bartonella, salmonella, and listeria.
4. Nosocomial endocarditis is most often caused Staphylococcus and enterococci; infections that are associated with indwelling catheters and medical-surgical procedures including hemodialysis and bone marrow transplant.
5. Culture negative endocarditis exhibits the usual bacterial organisms but they are masked by previous antibiotic therapy. Slow-growing penicillin-sensitive organisms with fastidious nutritional tastes may not be detected because special culture medium are required for their growth, isolation, and detection; also, Brucella, Chlamydia, and Coxiella may not be readily detected.

II. DIAGNOSIS

The diagnosis of endocarditis requires a high index of suspicion. The condition must be considered and carefully

excluded in all patients with a heart murmur and fever of undetermined origin that persists for more than a few days. Diagnosis is made in the majority of patients by three or four separate sets of blood cultures taken from a separate vein puncture site over 24 h.

Transesophageal echocardiography (TEE) is superior to transthoracic assessment in the search for infected vegetations located on heart valves and is crucial for the diagnosis of endocarditis. Transthoracic two-dimensional Doppler echocardiography gives poor detection of prosthetic heart valves, especially in the mitral position, and of calcific sclerotic native valves. Vegetations that are less than 5 mm, 6–10 mm, or greater than 10 mm are observed in 25, 65, and 70%, respectively, by transthoracic technique. This is 100% for all lesions using TEE.

Bacterial endocarditis is caused most often by infection with *Streptococcus viridans* (~40%) followed by *S. aureus* (~30%) enterococci in about 10–15% of cases. Other organisms include *Staphylococcus mitis*, *S. bovis*, *S. anginosus*, *Haemophilus influenzae*, *Pseudomonas aeruginosa*, *P. cepacia*, and *Serratia marcescens*.

III. THERAPY

Intravenous antibiotics are commenced soon after sufficient blood cultures are obtained; usually a combination of nafcillin (oxacillin or flucloxacillin), ampicillin, and gentamicin is administered. Changes are made when the organism and antibiotic sensitivities are established.

Organisms that commonly cause endocarditis and appropriate antibiotic combinations include the following:

1. *S. viridans* or *S. bovis*: If the MIC to penicillin is less than 0.1 µg/ml, give penicillin (IV 2–3 million U every 4 h for 4 weeks) or 2 weeks IV then amoxicillin (orally 500 mg every 6 h for 2 weeks) or ampicillin/sulbactam (2 g every 6 h for 2 weeks IV) and then amoxicillin (orally 500 mg every 6 h for 2 weeks) or penicillin and gentamicin IV for 2 weeks or ceftriaxone 2 g once daily IV for 2 weeks. Then IV or IM therapy once daily given as an outpatient or in the home is cost saving; but IM ceftriaxone is painful.
2. Partially sensitive *S. viridans* or *S. bovis*, MIC penicillin greater than 0.1 µg/ml: penicillin (3 million U every 4 h IV) plus gentamicin (1–1.5 mg/kg every 8 h IV for 2 to 4 weeks) or, from the third week, amoxicillin (500 mg orally every 6 h for 2 weeks).
3. *S. fecalis*, *S. fecium*, *S. durans*, or similar fecal streptococci are difficult to eradicate: If the length of illness is less than 3 months, it is advisable to give ampicillin/sulbactam (IV 2–3 g every 6 h for 4 weeks) plus

gentamicin (1–1.5 mg/kg every 8 h) and monitor levels and adjustment for renal function. Gentamicin is given for 4 weeks.

4. *S. aureus*: Methicillin-sensitive strains constitute the most cases of *S. aureus* endocarditis and these are treated with nafcillin or cloxacillin (at doses given above) or flucloxacillin (IV 2 g every 4 h) plus optional addition of gentamicin (1 mg/kg every 8 h IV) for 4–7 days; the dose is to be monitored by levels. The dose is reduced in elderly patients and those with renal dysfunction, whereas the dosing interval is increased. Gentamicin is discontinued after 1 week, and nafcillin or flucloxacillin IV is continued for 5–6 weeks. The length of treatment is usually from 4–6 weeks. In the UK, *S. aureus* endocarditis is usually treated with IV flucloxacillin from 4–6 weeks and gentamicin IV for 14 days.

Antiplatelet agents including aspirin, ticlopidine, and clopidogrel are not recommended because they increase the risk of bleeding in patients with endocarditis complicated by cerebral emboli; these agents may also decrease beneficial platelet induced bactericidal activity.

IV. PREVENTION

Prevention of some cases of bacterial endocarditis is achieved by intelligent use of appropriate antibiotics on the day of dental or other surgery. Approximately 25% of cases of endocarditis are believed to be of dental origin and in approximately 75% of cases the portal of entry cannot be identified. In over 40% of cases infection occurs on valves not known to be abnormal, especially on bicuspid aortic valves and in patients with mitral valve prolapse. Except for prosthetic valves in which a powerful antibiotic regime is administered, prophylaxis is aimed at streptococci, which accounts for only about 65% of all cases of endocarditis.

The American Heart Association has guidelines for preventing bacterial endocarditis. Patients with valvular heart disease must be given antibiotics one hour prior to all dental or surgical procedures. The antibiotic is given orally for dental work done under local anesthetic. It is given intravenously for patients with prosthetic valves, patients with highest risk of developing endocarditis, or patients who are having a general anesthetic. All dental procedures that are likely to result in gingival bleeding such as extractions, root canal, scaling and cleaning, surgery in the oral cavity, biopsies, and many surgical operations and tests such as cystoscopy require antibiotic coverage to prevent endocarditis.

Another guideline includes oral antibiotic therapy to be given when a local anesthetic is used such as amoxicillin

2 g one hour prior to the procedure. Patients allergic to penicillin usually receive clindamycin 600 mg one hour prior to the procedure. For surgery on the intestine or the genitourinary systems, other antibiotics are required intravenously. Patients must warn the doctor in the hospital or dentist regarding the presence of heart valve disease that require prophylactic antibiotics. Prophylactic regimens are given in Tables 1 and 2.

A. Case History I

Mrs. S., age 69, had a fever of 100–104°F with chills and weakness over a period of 14 months. She had attended several clinics and physicians including one period of hospitalization. She was previously quite well and was not known to have heart disease. She had six children who were alive and healthy, and it was a surprise to them that their previously healthy mother was now bedridden. She was not short of breath and there was no cough. The diagnosis was obvious. The woman had a soft systolic murmur at the apex of the heart and typical swelling of the fingertips near the nailbed called finger clubbing. Clubbing is a hallmark of bacterial endocarditis. On questioning, she admitted that 14 months previously she had all her teeth removed. She was treated with a combination of penicillin and streptomycin for a period of 6 weeks and she made an uneventful recovery. Ten years later she was alive and well.

B. Case History II

One unfortunate morning L. H., a 29-year-old female who was known to have a soft heart murmur, was walking to the bathroom and fell to the floor. Her left arm felt weak and her speech was slurred. She was rushed to the hospital, and after three days she made a complete recovery and was discharged.

Three weeks later she had the typical features of finger clubbing, murmur, and fever and was admitted to the hospital. She had a temperature of 100–102°F. Her blood was taken and cultured and grew a bacteria called *S. viridans*. This is the most common cause of bacterial endocarditis. She was treated with penicillin and streptomycin for 6 weeks and made a good recovery. Her previously mild mitral valve regurgitation became moderate. Twenty-five years later, she is able to do her usual work, exercises, and enjoys life with minimal restrictions.

Apart from infection of previously damaged heart valves as well as prosthetic valves, normal valves can become damaged. Fortunately this is extremely rare and seen mainly in drug addicts. Contaminated syringes and needles may introduce germs into the bloodstream and can infect valves on the right side of the heart (tricuspid and pulmonary valves). These germs are very active growing types; thus, they can damage normal valves. The bacteria found in such cases are staphylococcus and pseudomonas.

Preventive medicine has helped to eradicate streptococcus not only by the use of antibiotics but also through the relief of overcrowding and the improvement of sanitation and ventilation in disadvantaged socioeconomic groups. Thus, rheumatic fever is now rare in North America but is common in India, Pakistan, Africa, the West Indies, and South America.

BIBLIOGRAPHY

- Cabell, C. H., Abrutyn, E., and Karchmer, A. W. Bacterial endocarditis. The disease, treatment, and prevention. *Circulation*, 107:e185, 2003.
- Khan, M. Gabriel *Cardiac Drug Therapy*, sixth edition, W. B. Saunders, Philadelphia, 2003.
- Moreillon, P., and Que, Y.-A. Infective endocarditis. *Lancet*, 363:139–149, 2004.
- Remadi, J. P., Najdi, G., Brahim, A., Coviaux, F., Tribouilloy, C. et al. Superiority of surgical versus medical treatment in patients with *Staphylococcus aureus* infective endocarditis, pages 195–199.

Endocrine Disorders and the Heart

- I. Acromegaly
- II. Thyroid Diseases
- III. Adrenal Disorders

GLOSSARY

angina chest pain caused by temporary lack of blood to an area of heart muscle cells, usually caused by severe obstruction of the artery supplying blood to the segment of cells.

arrhythmia general term for an irregularity or rapidity of the heartbeat, an abnormal heart rhythm.

cardiomyopathy heart muscle disease.

heart failure failure of the heart to pump sufficient blood from the chambers into the aorta; inadequate supply of blood reaches organs and tissues.

myocardial infarction death of an area of heart muscle due to blockage of a coronary artery by blood clot and atheroma; medical term for heart attack or coronary thrombosis.

myocardium heart muscle.

tachycardia increase in heart rate exceeding 100 beats per minute.

I. ACROMEGALY

The anterior pituitary gland secretes at least seven polypeptide hormones. Two of these hormones are released by the hypothalamus: somatostatin-releasing hormone which stimulates growth hormone secretion and somatostatin which regulates the release of growth hormone from the anterior pituitary. Growth hormone regulates an individual's growth. It also increases the heart rate and myocardial contractility. Specific receptors for growth hormone in the myocardium promote cardiac remodeling, increased contractility, and myocytic hypertrophy. Excess growth hormone secretion causes acromegaly. With this disease, the left ventricle mass, stroke volume, and

cardiac output increase significantly. Virtually all cases of acromegaly are caused by a chromophobic or eosinophilic adenoma of the pituitary. Rarely, it is caused by excessive secretion of the somatostatin-releasing hormone from the hypothalamus.

A. Clinical Features

These features include enlargement of the heart, premature coronary artery disease, congestive heart failure, hypertension, intraventricular conduction defects, and cardiac arrhythmias. Mild hypertension occurs in more than 50% of patients. Other manifestations include headache; visual field defects (bitemporal hemianopsia); the growth of the hands, feet, and head; coarsening facial features with elongation of the jaw giving a typical lantern-jaw appearance; enlargement of the liver; and glucose intolerance.

Acromegalic cardiomyopathy occurs, albeit rarely. There is myocyte hypertrophy and an increase in the collagen content per gram of heart compared with normal myocardium. The defect in the myocardium causes arrhythmias, which weaken the myocardial force that leads to congestive heart failure. Treatment of patients with somatostatin analogs that inhibit secretion of growth hormone, octreotide and lanreotide, have shown beneficial effects in small studies. In some patients congestive heart failure has been completely controlled. The left ventricle mass index and mean wall thickness have also shown improvement with this therapy. Still, in patients with long-standing acromegaly there is nonreversible interstitial fibrosis with little recovery.

B. Management

Heavy particle, proton beam irradiation or surgery is usually curative. Hypertension can be controlled with diuretics or other antihypertensive agents and acromegalic

cardiomyopathy may show some amelioration with the administration of octreotide.

II. THYROID DISEASES

A. Thyrotoxicosis

Hyperthyroidism (thyrotoxicosis) is caused by an excessive secretion of thyroid hormone, L-thyroxine. This hormone has direct cardiac effects manifesting in a marked increase in heart rate and myocardial contractility.

I. Clinical Features

Symptoms of thyrotoxicosis include heat intolerance, excessive sweating, nervousness, irritability, anxiety, marked weight loss, increase in appetite, and palpitations with fast heart rates. Palpitations may be caused by a marked increase in heart rate, but the heart rhythm may become irregular because of the occurrence of atrial fibrillation. Physical signs include tachycardia, agitation, enlargement of the thyroid gland, and typical eye signs. Atrial fibrillation with a rapid heart rate of more than 150 beats may force patients to seek attention. Increasing shortness of breath is usually caused by excessive cardiac work resulting in myocardial dysfunction and heart failure.

2. Management

The cardiovascular manifestations of thyrotoxicosis are often resistant to therapy. Atrial fibrillation does not respond to treatment with digoxin, and the beta-blocking agents are most useful in controlling the fast heart rate evidenced in sinus tachycardia or caused by atrial fibrillation until specific treatment of the thyroid disturbance becomes effective. Irradiation with radioactive iodine or surgical removal is usually successful.

B. Hypothyroidism (Myxedema)

I. Cardiovascular Manifestations

The heart may become dilated and the heart rate is often reduced to less than 50 beats per minute. The heart muscle is partially replaced by interstitial fibrosis with weakening of the cardiac muscles resulting in heart failure. There is a marked increase in serum cholesterol and angina or myocardial infarction occurs prematurely. Electrocardiogram

shows sinus bradycardia, elongation of the QT interval, and low voltage.

2. Management

These cardiac complications are rarely seen because of more efficient diagnosis and treatment. Administration of L-thyroxine in adequate doses usually produces beneficial results after 3–6 months of therapy.

III. ADRENAL DISORDERS

A. Cushing's Syndrome

This disorder is caused by either an ACTH-dependent adenoma or an ACTH-independent adenoma. Cushing's disease in greater than 70% of the cases is caused by ectopic ACTH syndrome, and 10% percent of the time it is caused by an ectopic corticotropin-releasing hormone. An ACTH-independent adrenal adenoma causes Cushing's syndrome in 10% of cases, it is caused by adrenal carcinoma in 10% of the cases, and rarely it is seen in micronodular adrenal diseases and during iatrogenic exogenous glucocorticoid administration.

I. Clinical Manifestations

These manifestations include a characteristic form of truncal obesity which involves the abdomen, chest, and the upper back causing a buffalo hump. The upper and lower limbs are thin and some wasting and weakness of the upper thigh muscles (the quadriceps) occurs. Because of this, the patient has difficulty climbing stairs.

Cardiovascular complications such as hypertension may be severe. Diabetes may occur and along with hypertension this increases the risk for myocardial infarction. Accelerated atherosclerosis is a common finding in patients not treated early in the course of this disease.

2. Management

Cushing's disease requires transphenoidal pituitary surgery and adrenal tumors require adrenalectomy. Ectopic ACTH syndrome occurs and requires treatment of the underlying tumor. Correction of hypokalemia with potassium replacement and spironolactone and drugs that block steroid synthesis may be also be required.

B. Hyperaldosteronism

Hyperaldosteronism is usually caused by an aldosterone-producing adenoma and rarely by bilateral adrenocortical hyperplasia.

I. Clinical Manifestations

Potassium depletion occurs that may produce muscular weakness. Sodium retention causes an increase in blood pressure, but hypertension is usually mild to moderate in intensity. It may be resistant to the usual antihypertensive medications.

Aldosterone has a direct effect on collagen metabolism in cardiac fibroblasts and reactive perivascular and interstitial cardiac fibrosis occurs. Aldosterone appears to increase plasminogen activator inhibitor type 1 expression and secretion and contributes to the inflammatory response accompanying microvascular disease. The weak diuretic, spironolactone, an aldosterone antagonist, has been shown in a large randomized clinical trial in patients with severe heart failure to reduce mortality and morbidity. A new agent, eplerenone, has the same actions as spironolactone and has also been shown to reduce mortality and morbidity in a large randomized trial of patients with severe heart failure (see the chapter Diuretics).

C. Pheochromocytoma

This disorder is an extremely rare. The lesion is usually a tumor of the adrenal medulla (~10% are bilateral), 10% of the time it is malignant, and 10% of the time it is outside the adrenal medulla where 10% of those are familial.

I. Cardiovascular Manifestations

Cardiovascular manifestations of pheochromocytoma include severe headaches and profuse sweating, palpitations, severe labile hypertension or sustained severe

hypertension, palpitations due to sinus tachycardia, and cardiac arrhythmias. A life-threatening myocarditis may occur, and in some cardiomyopathy and heart failure may develop that may be reversed when the offending tumor is removed.

Diagnosis requires the finding of an elevated 24-h urine total of metanephrines and an increase in plasma catecholamines. Elevated dopamine serum levels are estimated on the same blood samples taken for epinephrine, because dopamine may be the only chemical produced by some malignant pheochromocytomas. An MRI may reveal a tumor.

2. Management

Hypertensive crisis may require use of phentolamine before the administration of phenoxybenzamine. Nitroprusside should be used to lower blood pressure during a crisis and nifedipine is also useful for emergency blood pressure control. Surgery provides an expected cure in up to 80% of patients.

BIBLIOGRAPHY

- Masoudi, F. A., Inzucchi, S. E., Wang, Y., Havranek, E. P., Foody, J. M., Krumholz, H. M. et al. Thiazolidinediones, Metformin, and outcomes in older patients with diabetes and heart failure: An observational study. *Circulation*, 111:583–590, 2005.
- Moreno, P. R., Fuster, V. et al. New aspects in the pathogenesis of diabetic atherothrombosis. *J. Am. Coll. Cardiol.*, 44:2293–2300, 2004.
- Ripoli, A., Pingitore, A., Favilli, B., Bottoni, A., Turchi, S., Osman, N. F., De Marchi, D., Lombardi, M., L'Abbate, A., Iervasi, G. et al. Does subclinical hypothyroidism affect cardiac pump performance? *JACC*, 45:439–445.
- Seely, E. W., and Williams, G. H. The heart and endocrine disorders. In *Heart Disease*, sixth edition. E. Braunwald, D. P. Zipes, and P. Libby, eds. W. B. Saunders, Philadelphia, 2001.
- Weinstein, A. R., Sesso, H. D., Lee, I. M. et al. Relationship of physical activity versus body mass index with type II diabetes in women. *JAMA*, 292:1188–1194, 2004.

Erectile Dysfunction and the Heart

- I. Mechanism of Erectile Dysfunction
- II. Causes of Erectile Dysfunction
- III. Management

GLOSSARY

- dyslipidemia** the same as hyperlipidemia, elevated blood cholesterol, LDL cholesterol, triglycerides, or low HDL cholesterol.
- endothelium** the innermost part of the intima that comes in contact with circulating blood, a silky smooth layer of epithelial cells.
- heart failure** failure of the heart to pump sufficient blood from the chambers into the aorta; inadequate supply of blood reaches organs and tissues.
- ischemia** temporary lack of blood and oxygen to an area of cells, for example, the heart muscle, usually due to severe obstruction of the artery supplying blood to this area of cells.
- myocardial infarction** death of an area of heart muscle due to blockage of the coronary artery by blood clot and atheroma; medical term for a heart attack or coronary thrombosis.

ERECTILE DYSFUNCTION (ED) IS OBSERVED OFTEN in men with cardiovascular disease. In a Boston survey of 1790 free living men age 40–70, 50% reported some degree of ED — 10% severe and 25% moderate. ED occurs in men worldwide and has several causes, but cardiovascular disease and diabetes play a major role in many individuals. Some investigators have suggested that ED may serve as a predictor for cardiovascular disease, because in both conditions endothelial dysfunction is deranged. Endothelial dysfunction is a well-defined entity and is a major player in the pathogenesis of atherosclerosis, its complications, and symptomatology. Endothelial dysfunction shares many common risk factors with both atherosclerotic vascular disease and ED.

I. MECHANISM OF ERECTILE DYSFUNCTION

A. Physiology of Penile Erection

ED is a disorder of the blood supply to the penis. Nitric oxide (NO) bioavailability is at the core of normal and abnormal erectile function. Nitric acid is synthesized from the amino acid L-arginine in response to sexual stimulation. Physical or emotional stimulation causes brain or neuronal NO synthase (bNOS) located in nonadrenergic, noncholinergic cavernous nerves of the penis to release NO. Nitric oxide is a powerful dilator of blood vessels and is formed during the conversion of L-arginine to L-citrulline by the enzyme NO synthase. It is a small unstable molecule that mediates many of the normal functions of the endothelial lining of blood vessels.

The endothelium is the inner lining of blood vessels that is in contact with circulating blood. NO is responsible for neurally induced vasomotor changes at the level of the corpora cavernosa which generates penile erection. Also, cholinergic nerves release acetylcholine, which acts on the surface receptors of endothelial cells leading to activation of endothelial NO synthase (eNOS) and in healthy endothelium it releases significant levels of NO. The bioactive NO diffuses to the trabecular smooth muscle cells surrounding the sinusoidal spaces and acts on guanylyl cyclase, which generates cyclic guanosine monophosphate (cGMP). This has a vasodilatory effect and appears to cause relaxation of the cavernosal smooth muscle, allowing a marked inflow of blood into the sinusoidal spaces and engorgement of the penis. As the penis fills with blood, a veno-occlusive process comes into play blocking the outflow of blood. This maintains the erection (see Fig. 1).

There is arterial dilatation with increased inflow of blood and cavernous filling followed by entrapment of blood. It is believed that the essential relaxation of the corpus cavernosal smooth muscle required for penile

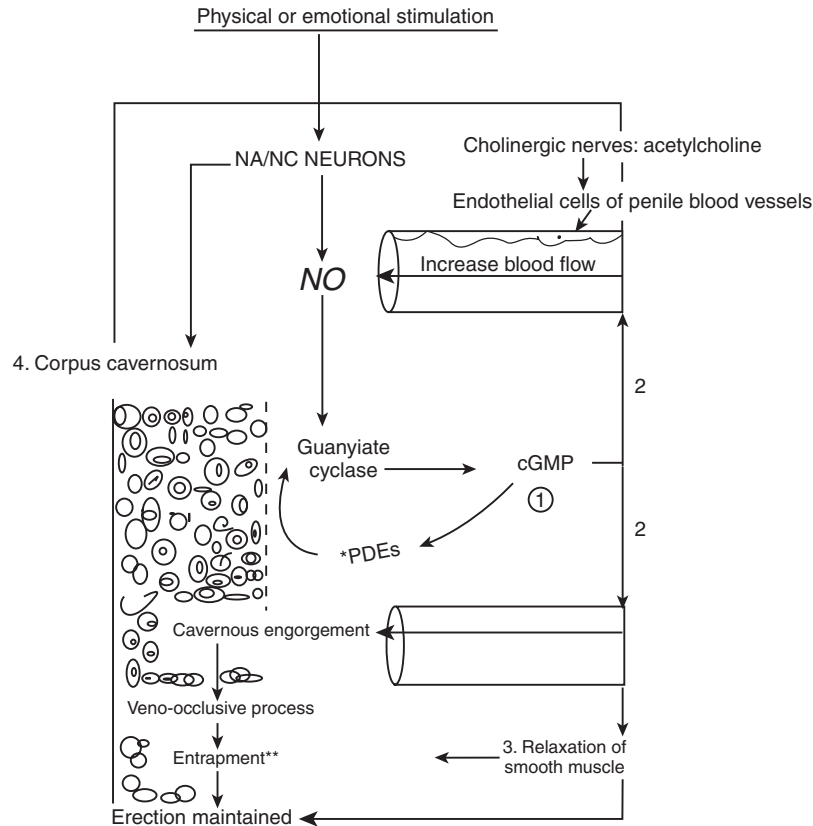

FIGURE 1 Normal physiology of penile erection.

erection involves a nonadrenergic, noncholinergic mechanism mediated by NO and cGMP, but the exact mechanism needs further elucidation (Fig. 1).

A state of increased oxidative stress renders NO inactive. Release of norepinephrine from adrenergic nerves enhanced by many stimuli, coupled with the endothelial release of endothelin, induces smooth muscle cell contraction and hinders penile erection. Endothelin is a potent vasoconstrictor and endothelial dysfunction increases the synthesis and release of endothelin. The same pathophysiologic processes generate a temporary decrease in blood supply through the coronary arteries to the heart muscle during attacks of anginal chest pain. Endothelial dysfunction plays a role, therefore, in both ED and ischemic heart disease.

Erectile dysfunction may be the presenting symptom in patients who have diseases characterized by endothelial dysfunction such as coronary artery disease, diabetes mellitus, hypertension, and dyslipidemias. Nobel Laureate R. F. Furchgott brought endothelial dysfunction to light when he observed that arteries denuded of endothelium contracted in response to acetylcholine, while normal arteries dilated. There is little doubt that endothelial dysfunction is caused in many instances by a decrease in

the bioavailability of endothelial NO, and ED is often caused by decrease in NO of endothelial or neural origin.

All the common risk factors for cardiovascular disease are associated with an enhanced oxidative stress and endothelial dysfunction. The production of superoxide is increased in these conditions and causes inactivation of NO. Cardiovascular risk factors increase the production of superoxide in endothelial cells where NO is produced causing immediate decrease in NO bioavailability, even when normal amounts are produced. Thus, the amount of bioactive NO is a function of the state of oxidative stress in the endothelium as much as of the total amount of NO synthesized by eNOS and in the situation of penile erection, also by bNOS. Mechanisms are not complete, however, because NO is not only released from endothelial cells but also from neurons in smooth muscle and possibly from the cavernous smooth muscle cells. So endothelial dysfunction, now proclaimed by many to be the root of the problem, may be only a branch (see Fig. 1).

In addition, the corpus cavernosum does not contain much muscle. Virtually all of the corpus cavernosum consists of a fine sponge-like framework whose interspaces communicate freely with one another and are filled with blood (Fig. 1). These spaces lead directly into veins of

the penis. The size of the penis varies with the amount of blood in the erectile tissue, and there is more blood than muscle. Relaxation of muscle may not be as important a feature as stated in most descriptions of ED, and the use of phosphodiesterase inhibitors and the accumulation of cGMP causes a marked inflow of blood followed by entrapment of blood that maintains the erection.

II. CAUSES OF ERECTILE DYSFUNCTION

Psychogenic factors including depression are common causes of ED. About 25–75% of patients with depression experience some degree of ED. Cigarette smoking and alcohol have a negative impact on penile blood flow as well as on the nerve supply. Cigarette smoking appears to cause a constriction of small penile arteries.

More than 30% of cases of ED are estimated to correlate with a comorbid illness. Pathologic causes of ED include the following:

- Vascular disease, ~40%
- Diabetes mellitus, ~20%
- Severe dyslipidemia, ~10%
- Medications, >5%
- Endocrine, ~5%
- Urologic, ~5%
- Neurologic, <2%
- Other, ~13%: renal and hepatic failure, HIV infection, all forms of cancer.

A. Cardiovascular Disease

In epidemiologic studies hypertension, coronary artery disease, and peripheral vascular disease are frequently associated with ED. Approximately 75% of men with coronary artery disease have ED with the condition severe in greater than 25%. Several studies support the association between ED and coronary artery disease and correlate coronary disease with difficulty in achieving erections. In some, the onset of ED predated the symptoms and diagnoses of coronary disease by a few months to a year.

Men with two- or three-vessel obstructive coronary artery disease were observed to have significantly fewer erections during a 30-day period and scored lower on an index of erection firmness than men with single-vessel disease. In a study of 50 men with ED of presumed vascular origin, multiple risk factors were present in 80%, smoking in 80%, and elevated total cholesterol greater than 200 mg/dl (5.2 mmol/L) in 70%. Coronary angiograms in 20 of these individuals showed significant coronary artery obstructive lesions: severe left main or

three-vessel disease in 6, two-vessel disease in 7, and single-vessel disease in 7, and graded exercise testing was positive in 28 (56%) of these subjects.

In a study of 76 men with proven chronic coronary heart disease, age 40–80 (24 with bypass surgery, 29 with angioplasty and stents), 25% were observed to have severe ED, and more than 75% had difficulty in starting or maintaining erections.

There is a high prevalence of cardiac risk factors that underlie both endothelial dysfunction and significant coronary artery disease in asymptomatic men with ED. Because urologic problems account for less than 6% of cases of ED, cardiologists and physicians caring for patients with heart disease are now advised to assess patients for the presence of ED and to arrange for its management prior to referral to a urologists.

B. Diabetes

Diabetes is a common cause of cardiovascular disease and the most common cause of death in the diabetic patients is a heart attack. In large randomized clinical trials of patients with coronary heart disease, angina, or heart failure diabetics usually represent about 25% percent of the patient population. Most patients with type 2 diabetes have severe dyslipidemia, coronary artery disease, or hypertension, all of which are associated with endothelial dysfunction and ED. More than 50% of patients with diabetes develop ED during the course of their illness.

C. Other Causes

Endocrine causes represent less than 5% of patients and yet many patients are referred to endocrinologists. The majority of men who have ED have been found to have normal testosterone levels. Thyroid, pituitary, and adrenal diseases may cause ED, albeit rarely. A urologist's opinion is rarely required and yet most patients first seek the advice of a urologic specialist. Prostate surgery may cause some degree of ED in greater than 50% of patients.

III. MANAGEMENT

A. Phosphodiesterase Inhibitors

Three phosphodiesterase-5 (PDE5) inhibitors, sildenafil (Viagra), vardenafil (Levitra), and tadalafil (Cialis) have been approved and are effective in a broad population of men with ED. PDE5 inhibitors cause improvement of ED by preventing the breakdown of cyclic GMP, the substance that promotes relaxation of smooth muscle cells in the

arteries, arterioles, and sinusoids of the corpus cavernosum of the penis. Phosphodiesterases are enzymes that hydrolyze cGMP, a prime mediator of vasodilation. Sildenafil, a phosphodiesterase inhibitor, has a high affinity for the phosphodiesterase-5 (PDE-5) isoform that is abundant in the corpus cavernosum vascular smooth muscle, visceral and skeletal muscle, and in platelets. Figure 1 indicates both the normal physiology of penile erection and that inhibition of PDE-5 causes accumulation of cGMP. This accumulation produces arterial dilatation and increased blood flow to the corpus cavernosal smooth muscle. The exact mechanism for penile smooth muscle relaxation following NO-induced cGMP accumulation and the veno-occlusive phenomenon which causes entrapment of blood that maintains engorgement and sustains the erection remain unclear (Fig. 1).

B. Sildenafil

Sildenafil was originally developed as an antihypertensive agent, but the fortunate observation of the interesting side effects for ED provided us with an excellent addition to our armamentarium that improves the quality of life of many worldwide. More than one billion tablets of sildenafil have been used.

Sildenafil is usually taken as a 50-mg tablet about one hour before sexual activity. The maximum dose is 100 mg. The drug requires sexual stimulation to be effective. The 25-mg tablet is advisable in patients with blood pressure in the low normal range of 110–120 mmHg, in individuals over age 70, and in those with renal dysfunction or liver disease. The drug becomes effective from a half an hour to 2 hours and lasts about 4 hours.

1. Side Effects

Adverse effects of the three available drugs are headache, flushing, indigestion, and an erection lasting more than 4 hours, which requires emergency treatment to prevent damage to the penis.

2. Contraindications

Below is a list of contraindications for the use of sildenafil, vardenafil, and tadalafil.

1. Individuals with low blood pressure of less than 100 mmHg systolic should avoid these drugs; it is also advisable, however, to avoid the drug if the systolic blood pressure is frequently less than 110 mmHg

2. Patients with uncontrolled hypertension with blood pressure greater than 180 systolic or greater than 105 mmHg diastolic
3. Patients with heart failure or coronary artery disease manifested by unstable angina or with angina that has shown even a minimal increase in severity and that may provoke the use of nitroglycerin
4. In patients with retinitis pigmentosa
5. Concomitant use of agents that use the cytochrome P450 3A4 pathway: erythromycin, azithromycin, cimetidine, ketoconazole, antifungal agents, protease inhibitors, and probably some statins (see Table 1)

TABLE I

List of Representative Organic Nitrates

<i>Nitroglycerin</i>
Deponit
Minitran
Nitrok
Nitro-Bid
Nitrocine
Nitroderm
Nitro Disc
Nitro-Dur
Nitrogard
Nitroglycerin
Nitroglycerin T/R
Nitroglyn
Nitrol ointment
Nitrolingual spray
Nitrong
Nitro-Par
Nitropress
Nitro SA
Nitrospan
Nitrostat
Nitro-trans system
Nitro transdermal
Nitro-Time
Transiderm-Nitro
Tridil
Isosorbide mononitrate
Imdur
ISMO
Isosorbide mononitrate
Monoket
<i>Isosorbide nitrate</i>
Dilatrate-SR
Iso-Bid

(continued)

TABLE I
Continued

Isordil
Isordil tembids
Isosorbide dinitrate
Isosorbide dinitrate LA
Sorbitrate
Sorbitrate SA
<i>Pentaerythritol tetranitrate</i>
Peritrate
Peritrate SA
<i>Erythryl tetranitrate</i>
Cardilate
<i>Isosorbide dinitrate/Phenobarbital</i>
Isordil w/PB
<i>Illicit substances containing organic nitrates</i>
Amyl nitrate or nitrite (It is known that amyl nitrate or nitrite is sometimes abused. In abuse situations, amyl nitrate or nitrite may be known by various names, including “poppers.”)
Drugs that are Metabolized by or that Inhibit Cytochrome P450 3A4
<i>Antibiotic/antifungal</i>
Biaxin (clarithromycin)
Clotrimazole
Erythromycin
Diflucan
Sporanox
Ketoconazole
Miconazole
Noroxin
Troleandomycin
<i>Cardiovascular</i>
Amiodarone
Norvasc
Digitoxin
Diltiazem
Disopyramide
Plendil (felodipine)
DynaCirc (isradipine)
Cozaar (losartan)
Posicor (mibefradil)
Nifedipine
Quinidine
Verapamil
<i>HMG</i>
Lipitor (atorvastatin)
Mevacor (lovastatin)
Zocor (simvastatin)
<i>Central nervous system</i>
Alprazolam

(continued)

TABLE I
Continued

Carbamazepine
Prozac (fluoxetine)
Luvox (fluvoxamine)
Imipramine
Serzone (nefazodone)
Phenobarbital
Phenytoin
Zoloft
Triazolam
<i>Others</i>
Acetaminophen
Hismanal (astemizole)
Tagamet (cimetidine)
Prepulsid (cisapride)
Cyclosporine
Dexamethasone
Ethinyl estradiol
Naringenin (grapefruit juice)
Prilosec (omeprazole)
Rifampin
Tacrolimus
Seldane (terfenadine)
Theophylline
Rezulin (troglitazone)
Viagra (sildenafil)
Protease inhibitors: Crixivan (indinavir), Norvir (ritonavir), Viracept (nelfinavir), Invirase (saquinavir)

Biaxin is a registered trademark of Abbott Laboratories. Diflucan, Norvasc and Zoloft are registered trademarks of Pfizer Inc. Sporanox, Hismanal and Propulsid are registered trademarks of Janssen Pharmaceutica Inc. Noroxin, Cozaar, Mevacor and Zocor are registered trademarks of Merck & Co, Inc. Plendil and Prilosec are registered trademarks of Astra Merck Inc. DynaCirc is a registered trademark of Noratis Pharmaceuticals Corporation. Posicor is a registered trademark of Roche Pharmaceuticals. Lipitor and Rezulin are registered trademarks of Parke-Davis. Prozac is a registered trademark of Eli Lilly and Company. Luvox is a registered trademark of Solvay Pharmaceuticals, Inc. Serzone is a registered trademark of Bristol-Myers Squibb Company. Tagamet is a registered trademark of SmithKline Beecham Pharmaceuticals. Seldane is a registered trademark of Hoechst Marion Roussel. Viagra is a trademark of Pfizer Inc.

- Concurrent use of oral nitrates or sublingual nitroglycerin; oral, sublingual, or any form of nitrate preparation should not be taken up to 48 h prior; combination with nitrates causes severe reductions in blood pressure, which can cause a heart attack, death, or stroke. Nitric oxide (NO) donors, (Nitroglycerin and all nitrates including those listed in Table 1 stimulate guanylate cyclase, which increases the production of

cyclic GMP. When nitrates are given at the same time as PDE5 inhibitors, there is both an increase in the production of cyclic GMP (due to the NO donor) and an inhibition of its breakdown (caused by the PDE5 inhibitor); this causes an accumulation of cyclic GMP with resulting intense vasodilation and severe hypotension

7. Sildenafil is well tolerated and safe in patients receiving most concomitant antihypertensive agents except for α -blockers. The label precaution advises that 50 or 100 mg sildenafil should not be taken within 4-hours of α -blocker (such as terazosin) administration

If angina occurs, a nitrate preparation should not be administered within 24 h for sildenafil, and for newer longer acting preparations 48 h may be required for the safe use of nitrates. In any event a patient with coronary artery disease who experiences angina during or following sildenafil use for intercourse should *take two or three baby size (80 mg) chewable aspirin and proceed immediately to an emergency medical facility*. Fortunately nitrates are not very useful in preventing myocardial infarction or serious cardiac events and more appropriate drugs are advisable. These include the use of a beta-blocker and morphine to abolish the chest pain until the patient is assessed further. The electrocardiogram and troponin levels are helpful in making decisions; coronary angiograms followed by revascularization remains the more suitable and advisable therapy in a patient with coronary disease who develops chest pain with use of PDE-5 inhibitors.

3. Cardiovascular Advice

In all cardiovascular patients it is necessary to determine the patient's risk. Risk stratification is necessary and if carefully documented, these agents can be used safely in more than 70% of patients with cardiovascular disease. PDE-5 inhibitors play a major role in improving quality of life and can be used in virtually all of stable patients with cardiovascular disease. This includes hypertension controlled with one or at the maximum two drugs, stable angina, Canadian Cardiovascular Society grade I–II, and patients with stable heart failure New York heart Association class I–II. Asymptomatic patients with prior myocardial infarction more than 1 year ago with no recurrent angina and a satisfactory exercise treadmill test may be given a trial of 25 mg.

Patients with stable coronary heart disease who can complete an adequate treadmill test without demonstrating ischemia: >6 metabolic equivalent (METs), are at a low risk for ischemia during intercourse with a familiar partner.

A heavy meal or excessive alcohol consumption should be avoided. Care should be taken to avoid concomitant use of the cardioactive agents listed in Table 1.

In 53 clinical trials with sildenafil in more than 6000 patients, no excess incidence of myocardial infarction or death was observed. Also, in a prescription event monitoring study in more than 5000 men in the UK, there was no increased incidence of myocardial infarction, death, or total mortality compared with the overall UK population.

4. Clinical study: Halcox et al.

Sildenafil was studied in 24 patients and an additional 24 patients with coronary artery disease and ischemia during exercise and 12 control subjects receiving either 100 mg or 10 mg of isosorbide dinitrate or placebo. Patients were studied during exercise on three separate days in a randomized, double-blind manner. Flow-mediated dilatation of the brachial artery was measured and coronary artery disease patients underwent treadmill exercise testing. Sildenafil was shown to dilate epicardial coronary arteries, improve endothelial dysfunction, and inhibit platelet activation in patients with coronary artery disease. The beneficial effects were modest and most important, not harmful. This agent has an intermediate effect on myocardial ischemia compared with isosorbide dinitrate and placebo.

It is of interest that sildenafil appears to be somewhat beneficial in the treatment of lung fibrosis and pulmonary hypertension; it causes preferential pulmonary vasodilatation and improves gas exchange in patients with severe lung fibrosis and secondary pulmonary hypertension.

C. Vardenafil and Tadalafil

Vardenafil (Levitra) is a potent and highly selective PDE-5 inhibitor with a long half-life of about 5 h. The drug is effective in about 30–60 minutes and lasts approximately 4 hours.

In a double-blind, crossover single-dose multicenter study, 41 men with reproducible stable exertional angina due to coronary artery disease received vardenafil 10 mg or placebo followed by exercise tolerance testing (5–10 METs).

Relative to placebo the drug did not alter exercise treadmill time to first awareness of angina and significantly prolonged time to ischemic threshold. Sildenafil

significantly prolonged time to ST segment depression, a greater than 1 mm change from baseline.

Tadalafil (Cialis) supplied; 10, 20 mg tablets. The drug has a long half-life of about 17 h and a duration of action of about 36 h. The drug is effective in 30–60 minutes and lasts up to 36 h. A topical agent, alprostadil, is currently being tested.

Vardenafil, and tadalafil appear to be well tolerated and safe in patients receiving most concomitant antihypertensive agents except α -blockers but caution is required. *Vardenafil is contraindicated in patients taking α -blockers as severe hypotension may be precipitated.*

Tadalafil is contraindicated in patients taking α -blockers except for 0.4 mg tamsulosin but caution is required.

Vardenafil has been shown to cause a small increase in QTc. The label warning says “should be avoided in patients with congenital QT prolongation and patients taking class IA antiarrhythmics,” (eg. quinidine, procainamide) or class III (eg. amiodarone, sotalol). Several agents known to prolong the QT interval should be avoided.

BIBLIOGRAPHY

- DeBusk, R., Dory, Y., Goldstein, I. et al. Management of sexual dysfunction in patients with cardiovascular disease and recommendations of the Princeton consensus panel. *Am. J. Cardiol.*, 86(2): 175–81, 2000.
- DeBusk, R. F. et al. Sexual activity in patients with angina. *JAMA*, 290:3129–3132, 2003.
- DeBusk, R. F., Pepine, C. J., Glasser, D. B. et al. Efficacy and safety of sildenafil citrate in men with erectile dysfunction and stable coronary artery disease. *Am. J. Cardiol.*, 93:147–153, 2004.
- Furchgott, R. F., and Zawadzki, J. V. The obligatory role of endothelial cells in the relaxation of arterial smooth muscle by acetylcholine. *Nature*, 288(5789):373–76, 1980.
- Ghofrani, H. A., Wiedemann, R., Schermuly, R. T. et al. Sildenafil for treatment of lung fibrosis and pulmonary hypertension: A randomized controlled trial. *Lancet*, 360:895–900, 2002.
- Halcox, J. P. J., Nour, K. R. A., Zalos, G. et al. The effect of sildenafil on human vascular function, platelet activation, and myocardial ischemia. *J. Am. Coll. Cardiol.*, 40:1232–40, 2002.
- Hermann, H. C., Chang, G., Klugherz, B. D. et al. Hemodynamic effects of sildenafil in men with severe coronary artery disease. *N. Engl. J. Med.*, 342:1622–1626, 2000.
- Kloner, R. A., Hutter, A. M., Emmick, J. T. et al. Time course of the interaction between tadalafil and nitrates. *J. Am. Coll. Cardiol.*, 42:1855–1862, 2003.
- Kloner, R. A. et al. Cardiovascular effects of the 3 phosphodiesterase-5 inhibitors approved for the treatment of erectile dysfunction. *Circulation*, 110:3149–3155, 2004. doi:10.1161/01.CIR.0000146906.42375.D3.
- Kloner, R. A., Hutter, A. M., Emmick, J. T. et al. Time course of the interaction between tadalafil and nitrates. *J. Am. Coll. Cardiol.*, 42:1855–1860, 2003.
- Kloner, R. A., Mohan, P., Norenberg, C. et al. Cardiovascular safety of vardenafil, a potent, highly selective PDE5 inhibitor in patients with erectile dysfunction: Analysis of five controlled clinical trials. *Pharmacol. Ther.*, 22:1371, 2002.
- Prasad, S., Wilkinson, J., Gatzoulis, M. A. et al. Sildenafil in primary pulmonary hypertension. *N. Engl. J. Med.*, 343:1342, 2000.
- Thadani, U., Smith, W., Nash, S. et al. The effect of vardenafil, a potent and highly selective phosphodiesterase-5 inhibitor for the treatment of erectile dysfunction, on the cardiovascular response to exercise in patients with coronary artery disease. *J. Am. Coll. Cardiol.*, 40:2006–12, 2002.
- Wilkens, H., Guth, A., Konig, J. et al. Effect of inhaled iloprost plus oral sildenafil in patients with primary pulmonary hypertension. *Circulation*, 104:1218–1222, 2001.
- Zhao, L., Mason, N. A., Morrell, N. et al. Sildenafil inhibits hypoxia-induced pulmonary hypertension. *Circulation*, 104:424–428, 2001.

Exercise and the Heart

- I. Benefits of Exercise
- II. Aerobic Exercise
- III. Isometric, Static Exercise
- IV. Weight Reduction and Exercise
- V. Effects on Blood Pressure and Atheroma
- VI. Effects on Blood
- VII. Clinical Studies of Exercise and Heart Disease
- VIII. Injuries During Jogging
- IX. How to Start an Exercise Program
- X. Exercise Stress Test
- XI. Conclusion

GLOSSARY

- afterload** arterial impedance, restriction to blood flow delivered from the left ventricle; force against which the myocardium contracts in systole; a major determinant of wall stress.
- angina pectoris** short duration, recurrent chest pain or pressure often accompanied by feelings of suffocation and impending doom; most frequently associated with lack of blood and oxygen to the heart muscle.
- arrhythmia** general term for an irregularity or rapidity of the heartbeat, an abnormal heart rhythm.
- atheroma** same as atherosclerosis, raised plaques filled with cholesterol, calcium, and other substances on the inner wall of arteries that obstruct the lumen and the flow blood; the plaque of atheroma hardens the artery, hence the term atherosclerosis (sclerosis = hardening).
- fitness** ability to undertake physical exercise without undue fatigue; the several types of fitness include aerobic, strength, coordination, and flexibility.
- maximal oxygen consumption** the most oxygen that the body can use in aerobic exercise; synonymous with maximal aerobic fitness.
- mitochondria** small spherical cytoplasmic organelles; mitochondria are the principal sites of ATP synthesis and contain enzymes of the citric acid cycle for fatty acid oxidation, oxidative phosphorylation, and other biochemical pathways. They contain their own DNA and ribosomes, replicate independently, and synthesize some of their own proteins.

myocardial infarction death of area of heart muscle due to blockage of a coronary artery by blood clot and atheroma, medical term for a heart attack or coronary thrombosis.

ventricular fibrillation the heart muscle does not contract but “quivers”; therefore there is no heartbeat (cardiac arrest) and no blood is pumped out of the heart; death occurs within minutes if the abnormal heart rhythm is not corrected.

I. BENEFITS OF EXERCISE

One of the main reasons for practicing some form of regular, moderate exercise is that it always makes you feel and look better. Exercise does not have to be vigorous or strenuous to achieve important goals. Important psychological benefits can be produced by moderate exercise such as the combination of brisk walking for 20–30 minutes, performing stretching exercises for 10 minutes, and where possible, cycling or swimming for 10–15 minutes daily or at least every second day. These simple exercises are practical, inexpensive, and not time-consuming.

Exercise is a necessary part of weight loss programs. It is impossible to lose weight without the use of regular exercise. Long-term weight reduction requires regular exercise. In addition, such exercises pose no danger to individuals over the age of 40 and yet are sufficient to cause relaxation and produce a sense of well-being and a mental attitude that can better deal with stress.

If you do 30–40 minutes of moderate exercise a day and add a favorite sport such as tennis, other racquet sports, or skiing, you will be considered relatively fit. By relatively fit, you have the stamina and energy to do your daily work and favorite sport without shortness of breath, muscle fatigue, or a pounding heart.

Some people between the ages of 15 and 40, as well as 15% of North Americans over the age of 40, seek to exceed these achievements. Individuals who engage in regular vigorous exercise often reach a new “high,” and studies have shown that high levels of endorphins are produced in the bodies of such individuals. Endorphins are opiate-like chemicals similar to morphine that increase pain threshold

and euphoria. With regular vigorous exercise, cardiovascular conditioning is quickly achieved. A minimum frequency of three aerobic training bouts of exercise per week repeated for many weeks is a necessary requirement to produce training adaptations. Exercise continued daily for several weeks improves the ability of the heart to pump blood causing more blood to be ejected from the left ventricle into the aorta, which carries blood to all organs and tissues of the body. However, the heart muscle itself is not strengthened and coronary arteries do not feed the heart indefinitely with more blood. Unfortunately, exercise does not prevent the formation of atheroma or atherosclerotic obstruction of coronary arteries and has little effect on the prevention of angina or heart attacks.

II. AEROBIC EXERCISE

Aerobic literally means “with air”; that is, oxygen is required. Aerobic exercise involves the rhythmic contraction and relaxation of large muscle groups and movement of joints, for example, brisk walking, swimming, cycling, jogging, and dancing.

Oxygen is obtained in the lungs and transported by the blood. Exercising muscles require an increasing supply of oxygen, glucose, and other constituents. The body gets the additional oxygen by increasing the rate of breathing, the heart rate, and the output of blood from the heart. The amount of blood pumped each minute (cardiac output) increases from the average resting value of about 5 L to around 20 L. A large part of this output goes to the exercising muscles.

During aerobic exercise oxygen is used by the muscles. Oxygen converts energy in glucose and fatty acids to the energy form, adenosine triphosphate (ATP). Muscle fibers require a direct source of energy such as ATP to contract and cause limbs to move during exercise. The quantity of oxygen consumed during aerobic exercise tells us how many calories of sugar and fats were used and quantifies the caloric cost of the exercise. Walking uses much less oxygen than a slow jog, which requires less oxygen than a fast run.

Aerobic exercises cause an increase in heart rate and systolic blood pressure. The diastolic blood pressure is unchanged or slightly increased and the blood flow through nonexercising muscles, the liver, intestine, and kidneys is reduced. If you exercise mainly your upper limbs, this will cause a slightly higher increase in heart rate and blood pressure than exercise utilizing the legs.

The oxygen consumption during maximal aerobic exercise is used to classify the work fitness of the heart.

The more heart-fit an individual is, the greater number of calories are used per minute before fatigue sets in.

A. Cardiopulmonary Physiology

1. Oxygen Consumption

The oxygen consumption of the body is equal in the steady-state to the uptake of oxygen in the lungs. In a normal subject the oxygen consumption is about 250 ml per minute. Moderate exercise, which increases the heart rate to about 125 beats per minute, increases oxygen consumption from 250–300 ml per minute to 1200–1500 ml per minute.

2. Cardiac Output

The cardiac output is matched to the total metabolic need of the body. The mechanisms that regulate cardiac output to achieve these metabolic needs are heart rate (pulse rate), myocardial contractility (contraction of the heart muscle during systole), preload, and afterload.

During preload the more the ventricles are distended and filled with blood during diastole, the greater the volume of blood ejected during the next systolic contraction of the ventricles. Conditions that decrease intravascular volume reduce ventricular filling and result in a smaller end diastolic volume. This reduces stroke volume. Thus, in individuals who are severely dehydrated or have lost a large quantity of blood from bleeding, the heart is unable to fill properly, and there is a drastic fall in cardiac output despite a marked increase in heart rate (see Fig. 1). Preload can be visualized as the amount of myocardial stretch at the end of ventricular relaxation (diastole) just before contraction of the ventricles (systole).

Afterload is defined as the ventricular wall stress or tension that develops during systolic contraction and ejection of blood into the aorta. It reflects the resistance that the left ventricle must overcome in order to empty its contents into the aorta and arterial tree (systemic circulation). Another simple definition of afterload is a wall of pressure against which the heart muscle must pump blood. When the wall is high the heart muscle must pump harder to overcome this resistance. This wall stress is expressed as force per unit area.

If there is no obstruction between the left ventricle and aorta, for example, at the aortic valve, the left ventricular systolic pressure or the arterial systolic pressure gives an approximation of the afterload. A higher pressure load caused by hypertension or an increased chamber size that occurs with heart failure or dilated cardiomyopathy can

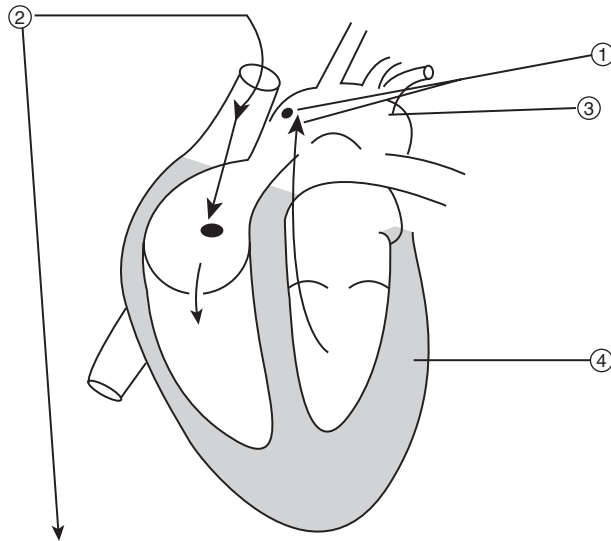

Heart rate \times stroke volume = Cardiac output * L/min.

FIGURE 1 The cardiac output and exercise. 1 = stroke volume = volume of blood ejected from the left ventricle into the aorta with each ventricular contraction; 2 = preload: filling the heart chambers with blood which is often expressed as end-diastolic volume or pressure; 3 = aorta and arteries: resistance = afterload. The force against which the myocardium contracts which is a major determinant of myocardial wall stress; 4 = left ventricle, normal contractility; * = normal, which is 6 liters per minute and varies from 3.5 to 7.5 liters per minute.

cause an increase in left ventricular wall stress. An increase in the wall thickness of the left ventricle is a compensatory player in reducing ventricular wall stress. Afterload is an important parameter; it is the force against which the myocardium contracts in systole and is a major determinant of wall stress.

Cardiac output = heart rate \times stroke volume (Fig.1)

The normal resting cardiac output is approximately 6 L per minute and varies from about 3.5 L per minute to 7.5 L per minute. The normal blood volume of about 5 L is composed of about 2.75 L of plasma and 2.25 L of red blood cells. The total volume of blood in the heart is about 600 ml, and the left ventricular volume at the end of diastole is about 150 ml. The stroke volume of the left ventricle (the amount of blood pumped from the ventricle into the aorta) is about 100 ml, and the amount of blood left in the left ventricle at the end of systolic contraction (the end systolic volume) is 50 ml. The ejection fraction is the fraction of the end diastolic volume ejected with each systolic contraction from the left ventricle into the aorta and this is $[100 \text{ divided by } 150] \% = 66\%$. Normal ejection fraction is greater than 50%.

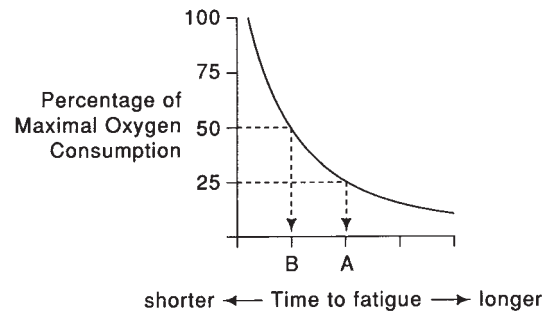

FIGURE 2 The time of work until the work cannot be continued any longer (due to fatigue) is inversely related to the percentage of maximal oxygen consumption invoked by the work being done. When person A has one-half the absolute value of maximal oxygen consumption of person B, and when persons A and B work at the same intensity or oxygen consumption, then person B will work a shorter time before fatigue, because person B is working at a higher percentage of his maximal oxygen consumption. (Reprinted with permission from Strauss, R.H. (1984). *Sports Medicine*, Philadelphia: W.B. Saunders, p. 44.)

B. Effect of Exercise

Moderate exercise to increase the heart rate to approximately 120 beats per minute causes an increase in stroke volume to ~ 125 ml, cardiac output to ~ 15 L, and oxygen consumption to 1200–1500 ml per minute. Blood gas tensions and pH do not change significantly. More severe exercise requires an oxygen consumption of ~ 2500 ml per minute, which is achieved by the trained athlete. An untrained individual shows evidence of accumulation of excess lactate and other acids that produce excess acidity of the blood called metabolic acidosis and this is reflected by a fall in pH. An individual with a high maximal oxygen consumption can either do the same workload for a longer period or undertake higher quantities of physical aerobic work for the same time than a person with a low maximal oxygen consumption.

An important aspect of the concept of maximal oxygen consumption in aerobic exercise is that its value determines how long an individual can work before becoming fatigued. The reason for fatiguing sooner when the percentage of aerobic effort is higher is that the time one can exercise aerobically at a given oxygen consumption is inversely related to the percentage of maximal oxygen that can be consumed per minute (see Fig. 2).

C. Caloric Costs of Work

Work is defined as force times the distance. During running work is the weight of the body times the distance moved. It is important to recognize that the effect of speed is small compared with distance; running one mile

uses only about 10 kcal more than walking, and walking five miles uses almost five times as many kilocalories as running one mile.

D. Cardiovascular Conditioning — Training Effect

The minimum amount of aerobic exercise required to improve the pumping capacity of the heart, or the delivery of more blood from the left ventricle into the aorta, is about 20–30 minutes daily for three to four days per week. Repeated for many weeks, this type of activity is necessary to produce training adaptations. During this level of exercise the heart rate (+ pulse rate) should reach approximately 70% of the calculated maximal rate for the individual.

$$\begin{aligned} &70\% \text{ of maximal heart rate} \\ &= 0.7 \times (\text{maximal heart rate} - \text{resting heart rate}) \\ &\quad + \text{resting heart rate} \end{aligned}$$

The maximal heart rate is obtained by subtracting the individual's age from 220. For a 70-year-old with a resting heart rate of 60, the maximal heart rate is 150 beats per minute and 70% of maximal heart rate is

$$0.7 \times (150 - 60) + 60 = 123$$

When a physically inactive individual suddenly decides to walk up four or five flights of stairs or commences unaccustomed aerobic exercise, he quickly gets winded or short of breath and feels the heart thumping away at a fast rate. The lack of physical fitness is obvious to the individual. If the same activity is repeated daily or every other day, after two or three weeks the individual no longer experiences the shortness of breath, the heart rate increases only slightly, and there is a faster return to normal resting heart rate after exercise. The training effect has been achieved and the heart, lungs, blood vessels, and muscles have started to adapt to the repeated exercise.

During exercise, muscles require an increase in oxygen supply. The lungs must take in more oxygen, the heart must pump faster and harder to get the oxygen to the muscles, and the muscles must extract more oxygen. The heart is a powerful muscular pump but needs oxygen to generate energy for its muscle contraction. The amount of oxygen the heart muscle requires at any time (myocardial oxygen consumption) can be determined by complicated techniques. A simple relationship, the product of the

heart rate and systolic blood pressure, has been shown to be a reliable indicator of the oxygen requirement for the heart muscle. Increased heart muscle efficiency is indicated by a decreased oxygen requirement for a similar amount of work. Regular exercise increases the efficiency of the heart muscle so that it requires less oxygen for the same amount of work. At rest, the heart muscle extracts about 65% of the oxygen reaching its muscle cells, and not much more can be extracted on exercise. Therefore, if the heart muscle requires more oxygen, the coronary arteries must dilate to supply more oxygenated blood. This situation can occur only if the coronary arteries are normal and capable of dilating.

With frequent exercise, the heart becomes conditioned to do the same work at a lower heart rate. You no longer feel your heart pumping away as if it wants to jump out of your chest or throat. If your exercise is then increased both in intensity and duration for at least 30 minutes daily, you will find that your resting heart rate may be reduced by 5–20 beats.

The heart rate is controlled by the brain and nerves that innervate the heart and the pacemaker (sinus node). The nerves that stimulate the heart to beat faster are called sympathetic nerves and they are stimulated from the brain. For example, if someone is going to attack you and you wish to flee, the sympathetic nerves are stimulated by the fright, anxiety, and tension. Noradrenaline produced by the nerve endings and adrenaline produced by the adrenal glands stimulate the heart to beat faster and stronger.

An opposing nerve called the vagus nerve (parasympathetic nerve) causes the heart to slow down. The vagus nerve is like the reins of a horse that keep the horse from running away out of control. Some individuals have an inborn, strong vagal nerve action and have a slow average resting heart rate that is about 64 instead of 72 beats per minute. Frequent exercise increases the effects of the vagal nerve (tightens the reins) and therefore leads to a slower heart rate. Many athletes have a resting heart rate of 35–50 beats per minute so that on exercise the heart rate goes up much less. In an untrained 50-year-old, a quarter-mile jog may produce a heart rate of 150–170 beats per minute. With training, the same exercise may cause a heart rate of only 120–140 beats per minute, and the product of heart rate and blood pressure will be reduced. It means that a conditioned heart will not have to work as hard to pump the same amount of blood. The heart muscle therefore requires less oxygen during the exercise.

The coronary arteries fill only when the heart muscle is relaxed (during diastole). A slower heart rate means that the heart is relaxed for a longer period of time and thus has more time to fill the normal or partially obstructed coronary arteries. Therefore, a better supply of oxygen

and other nutrients reaches the heart muscle. A fit heart idles at a lower speed and does not strain during maximal activity. The difference between the unfit and fit heart is similar to the performance of a poorly tuned 1934 car as opposed to a new 1996 model. Although frequent exercise may slightly lower your heart rate at rest and for a given exercise, there is lack of scientific evidence that this effect can prevent fatal or non fatal heart attacks. The slower heart rate does not prevent clot formation or atherosclerosis.

During exercise the requirement for oxygen by exercising muscle causes a lack of oxygen. Therefore, the rate at which you breathe increases from about 12 breaths per minute to 24–30 per minute, so that more oxygen is taken into the lungs and given up to the blood. Also during exercise resting muscles extract only about 30% of the oxygen from the blood bathing the muscle cells. Vigorously exercising muscle can extract over 75% of the circulating oxygen. The amount of oxygen extracted at peak exercise is your maximal oxygen uptake and reflects the limit of your endurance or cardiopulmonary (cardiovascular) conditioning. An increase in your maximal oxygen uptake is the adaptation of the body to aerobic

exercise. The body makes more efficient use of the oxygen available, and there is also less work for the heart. It is this physiological adaptation that allows you to have more stamina and less fatigue at a given level of aerobic exercise (Fig. 2).

Figure 3 illustrates the integrated control of multiple organs during aerobic exercise. Both the nervous and hormonal systems communicate to all organs and tissues during exercise, and each organ system undertakes a specific function. When all organ systems work together, sufficient oxygen and caloric fuel for the contraction of large masses of skeletal muscle during exercise is allowed. It also allows for elimination of metabolic by-products such as CO₂ from the lungs and hydrogen ions from the kidney, which prevent excessive acidity of the blood called metabolic acidosis.

The density of mitochondria and capillary networks increases in response to aerobic training. Increased mitochondria spare the body's stores of glucose during aerobic exercise and the trained skeletal muscle uses less glucose.

The process of muscle shortening requires the energy source ATP. The trained muscle uses fat as an energy source to make ATP. Glucose is stored as glycogen mainly

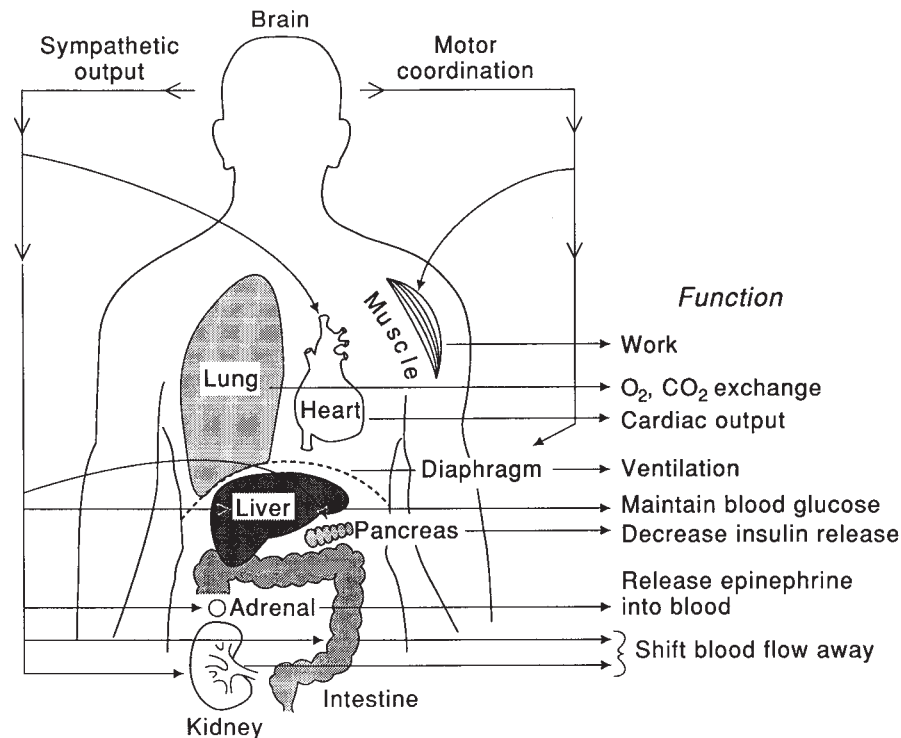

FIGURE 3 Integrative control of multiple organs during aerobic exercise. Both the nervous and hormonal systems communicate to all organs and tissues in the body during exercise and cause each organ system to undertake a specific function, so that the summation of all organ systems allows sufficient oxygen and caloric fuel for the contraction of large masses of skeletal muscle during exercise and allows for the elimination of metabolic by-products, such as carbon dioxide (from the lungs), and heat (from the skin), and hydrogen ions (from the kidneys). (From the *Encyclopedia of Human Biology*, second edition, Academic Press, San Diego, 1997.)

in the liver, and the storage is limited as glucose is rapidly used as fuel during exercise. When glucose concentration falls the body is unable to continue exercising at the same speed mainly because nerves and red blood cells can only use glucose to make ATP. A high-carbohydrate snack prior to intensive running delays exhaustion and fatigue. The training adaptation of glycogen-sparing permits running for longer periods at the same speed before glycogen depletion causes fatigue.

Aerobic exercise and hemorrhage initiate the same fight-or-flight reaction. During hemorrhage, blood pressure falls and insufficient blood and oxygen reaches organs and tissues. This signals nature's reflex survival mechanism. This mechanism includes stimulation of the sympathetic nervous system, which causes constriction and narrowing of arteries and arterioles. This increases total peripheral vascular resistance. Sympathetic stimulation increases the heart rate and myocardial contractility in an endeavor to increase cardiac output.

Blood pressure

$$= \text{cardiac output} \times \text{total peripheral resistance}$$

$$(\text{cardiac output} = \text{cardiac stroke volume} \\ \times \text{heart rate})$$

Epinephrine(adrenaline) and norepinephrine (noradrenaline) are fight-or-flight hormones that are immediately released from the adrenal glands. They cause increased cardiac contractility, increased heart rate, and constriction of arteries. This stimulates increased blood pressure to maintain the circulation of blood and oxygen to organs and tissues, which is a vital need for survival.

During aerobic exercise more blood and oxygen are required by exercising muscles so there is dilatation of arteries, arterioles, and a large capillary network to supply blood to these areas. These areas could be considered as empty cisterns that must be filled immediately. This can only be accomplished by an increase in cardiac output and increased blood pressure, which allows more blood to be delivered to fill the empty cisterns or vascular spaces. The heart beats faster and blood pressure increases as a normal physiologic response. The systolic blood pressure increases from 20 to 60 mmHg depending on the level of exercise. Thus a baseline systolic blood pressure of approximately 130 may reach 150–190 mmHg and in hypertensive individuals may exceed 220 mmHg.

E. Physiologic Hypertrophy

The left ventricular mass of trained athletes is approximately 40% greater than that of age-matched controls.

The athlete's heart becomes enlarged mainly in end diastolic cavity dimensions with lesser changes in end systolic dimension and in posterior wall and septal wall thickness. The hypertrophied heart has a 30–60% increase in stroke volume at rest and during exercise. This type of cardiac hypertrophy occurs within three to six months of vigorous training, and usually reverts back to baseline values within three to four weeks of detraining. Hypertrophy of heart muscle caused by exercise is an absolute increase in cardiac mass and does not result from hyperplasia (an increase in the number of cardiac muscle cells). Hypertrophy of the heart caused by exercise produces electrocardiographic and echocardiographic abnormalities (see the chapter Athletes and Sudden Cardiac Death).

III. ISOMETRIC, STATIC EXERCISE

Isometric means "equal measure." The muscle fiber length remains the same when muscular tension is exerted against a fixed resistance; that is, static exercise involves the development of tension within muscle fibers and results in little or no movement of bones and joints. Weightlifting and pushing against a wall are both examples of isometric exercise. Such exercise is also called resistance exercise.

Resistance exercise is generally not recommended for individuals who have hypertension, heart failure, or known heart disease, because it causes a marked increase in blood pressure during the effort. The pressure of tensed muscles squeezes blood vessels, and therefore, less blood passes through these arteries. Also, the constriction of blood vessels causes an increase in blood pressure. The heart works harder to pump against the resistance in the constricted arteries, but the amount of blood the heart pumps only increases slightly because the few muscles that are used require less oxygen than would be required during isotonic exercise. Despite this lower oxygen requirement of the exercising muscle during static exercise, the heart work is increased and the heart muscle requires more oxygen. During a double leg press in which a trained lifter is allowed to hold his breath, blood pressure can increase to greater than 250 mmHg systolic and greater than 130 mmHg diastolic. Pressures increase to overcome the high intramuscular pressures to maintain effusion of muscle tissue. The response to an acute resistance effort is a marked elevation of diastolic blood pressure, which is relatively unchanged during aerobic exercise. If atherosclerotic coronary artery disease is present, the heart muscle may suffer from a shortage of oxygen that can result in chest pain, angina, or precipitation of a heart attack (see the chapter Angina). Hypertensive individuals should not engage in isometric exercises.

During static exercise there is an increased heart rate and blood pressure, but only a mild increase in cardiac output and rate of breathing. Therefore, physical conditioning may be achieved, but the cardiopulmonary conditioning training effect cannot be obtained. Weightlifting produces increased strength of those skeletal muscles that are used but does not improve the capacity of the heart to work and does not increase blood circulation to the heart. Weightlifting and power training do not maintain an increased heart rate that is more than 70% of maximal heart rate for 30 consecutive minutes. Only aerobic exercise in which several strength exercises performed sequentially without rest periods in between produces some heart fitness.

Anaerobic exercise is different from aerobic exercise. Anaerobic means "without oxygen," and energy is derived from the breakdown of glucose in the blood and muscle with the formation of lactic acid. Static exercise such as moderate and heavy weightlifting or very high-intensity aerobic exercise such as a 100-yard sprints are examples of anaerobic exercise. Heart patients cannot take part in such exercises because they may precipitate heart failure.

IV. WEIGHT REDUCTION AND EXERCISE

A regular exercise program can cause mild weight reduction, which is greatly enhanced by a weight-reduction diet. Exercise is most helpful in long-term weight-reduction programs. Physical activity requires energy, which is measured in calories. Think of the body as having several factories. If you shut down half of these factories and let the other half work at half the speed, your output would be diminished. This is equivalent to turning down your metabolic rate (metabolic thermostat). If you go on a crash diet, your metabolic thermostat is turned down to get by on less food. Aerobic exercise 20–40 minutes done regularly three to four times weekly can boost your metabolic rate by 20–30%, and this will accelerate the breakdown of fat stores. The body of an obese individual is programmed to form fat and to store it away. In addition, your cells slow down and you burn fewer calories than normal. Cells slow down even more if you are on a severe weight-reduction diet to conserve energy. The more you exercise, the more dependent you become on fat metabolism. Many obese individuals do not overeat, but their metabolic rate is so low that they store fat. Therefore, start exercising first, then a few weeks later start your diet and continue on an exercise program for at least five years to keep the weight down.

The caloric equivalent 10 pounds of body fat is 36,500 kcal. Because only about 0.03 pounds of fat is used for

each additional mile done daily, reduction of body fat by aerobic exercise is a long-term process that can only be accomplished with exercise three or four times weekly for several years. Long-term body weight is a function of calories eaten minus calories burned.

To burn 100 calories, a 170-pound individual needs to walk briskly one to two miles or jog one mile. Note that brisk walking is nearly as good as jogging because the speed at which you complete the distance makes little difference to the total amount of calories you burn. Distance covered is more important than speed. As stated above, running one mile uses only 10 kcal more than walking; walking five miles uses almost five times as many kilocalories as running one mile.

Therefore, a brisk mile in 15–20 minutes twice daily or two miles once daily is of value until you can add other exercises. If you do this daily, you will lose one pound in less than 14 days. If your diet usually provides 1200–1500 calories daily and you drop to a 1000-calorie diet during this exercise program, you will have an additional one-pound loss in 14 days. This may seem small, but the good news is that in six months you will be 24 pounds lighter and you will be able to hold on to this reduction. Now that you are used to exercise, if you continue your program four days weekly, you will find it is easy to stay on a 1000- to 1200-calorie diet and maintain your ideal weight.

Exercise alone without restriction of calorie intake results in only mild weight reduction. Therefore, both exercise and diet should be used to achieve the best results. A combination of a low-carbohydrate and a low-saturated fat diet gives more sustained weight reduction of than only a low-saturated fat or only a low-carbohydrate diet. This allows a more balanced diet that can be tolerated by most individual over the long-term and has health benefits (see the chapter Diet and Heart Disease).

V. EFFECTS ON BLOOD PRESSURE AND ATHEROMA

Blood pressure is not significantly lowered during vigorous exercise. During vigorous exercise such as five miles of jogging or 20 minutes of continuous aerobic exercise, the systolic blood pressure increases markedly in most individuals. In many, the rise in blood pressure is substantial and it is possible that damage can occur in arteries during vigorous exercise. For example, a 40-year-old with a normal systolic blood pressure of 130 mmHg while running one to two miles, will usually have an increase in blood pressure during the run to about 150–180 mmHg.

There is usually no increase in the diastolic blood pressure except in patients who have hypertension. Blood pressure rapidly falls on cessation of exercise and returns to the normal resting level within a few minutes.

Individuals with mild hypertension who engage in a regular exercise program may obtain a slight reduction in their resting blood pressure, and this is believed to be due to a combination of factors including weight loss and relaxation. Therefore, indirectly, regular exercises are important to assist with weight reduction, thereby lowering blood pressure in individuals with mild hypertension. If you have moderate or severe hypertension, do not depend on exercise; it will not reduce blood pressure and can cause an increase in existing high blood pressure during vigorous exercise.

We cannot exclude the possibility that damage to arteries and dangerous atheroma formation and progression may be increased by vigorous exercise in some individuals. Increase in turbulent blood flow at the site of branching of arteries may initiate or cause progression of atheroma formation (see the chapter Atherosclerosis/Atherothrombosis). Atheromatous obstruction to the coronaries and other arteries is responsible for more than 14 million deaths annually worldwide, and this will increase to approximately 25 million deaths by the year 2020 and beyond in a population of approximately 7.5 billion. Walking two to three miles daily, swimming, cycling, and one hour of low-intensity aerobic exercise is safe and beneficial for most individuals including those with mild forms of heart disease or hypertension.

VI. EFFECTS ON BLOOD

A. Plasma Lipoprotein Cholesterol

Regular vigorous exercise increases high-density lipoprotein (good) cholesterol from 1 to 10%. It is debatable whether this slight rise in HDL cholesterol decreases risk over a long period of time. Moderate exercise has a variable effect. The total blood cholesterol and low-density lipoprotein (bad) cholesterol are not significantly reduced by exercise. Elevated triglycerides are reduced by exercise, but elevated triglycerides are not considered to be a definitive risk factor for coronary heart disease. The evidence linking elevated blood triglycerides with atheromatous disease of the coronary arteries remains weak.

1. Clinical Study

Kraus et al. performed a prospective randomized study of the effects of the amount and intensity of exercise on lipoproteins.

Methods: A total of 111 sedentary, overweight men and women with mild-to-moderate dyslipidemia were randomly assigned to participate for 6 months in a control group for approximately eight months in one of three exercise groups: high amount high-intensity exercise equivalent to jogging 20 miles per week; low amount high-intensity exercise equivalent to jogging 12 miles per week; or low amount moderate-intensity exercise equivalent to walking 12 miles per week. Individuals were encouraged to maintain their baseline body weight. In this study, 84 subjects complied with these guidelines and lipoprotein analysis was assessed.

Results: The highest amount of weekly exercise, with minimal weight change, had modest beneficial effects on blood lipoprotein profile. The improvements were related to the amount of activity and not to the intensity of exercise or improvement in fitness. Both lower amount exercise groups always had better responses than the control group.

Exercise training had no significant effect on the total cholesterol or LDL cholesterol concentrations. It did, however, exert effects on the concentrations of LDL cholesterol subfractions, but the clinical importance of this change is unclear. HDL cholesterol increased a modest 9% in the high amount high-intensity group; a change from baseline of 42.1 mg/dl to 45.9 mg/dl (9% change). There were no appreciable changes in HDL cholesterol in the other exercise groups.

Blood triglyceride levels showed a reduction in all exercise groups, as to be expected. Triglyceride concentrations are sensitive to weight loss and exercise, but as emphasized above triglyceride levels bear a low relationship to atheromatous coronary artery disease or vascular disease in general.

B. Other Effects

Vigorous exercise causes a variable effect on blood-clotting factors. A substance in the blood, factor VIII, is necessary for blood clotting and is absent in bleeders (hemophiliacs). Hemophiliacs who exercise get a mild and helpful increase in factor VIII. Vigorous exercise in healthy individuals increases factor VIII, as well as the number and stickiness of platelets. This is offset in healthy young individuals by a mild increase in factors that tend to dissolve blood clots. Individuals who have atherosclerosis of the artery present have an impaired ability to dissolve clots. Consequently, small clots (thrombi) may form on plaques of atheroma, thus increasing their size. Slowly, over 5–10 years, this may cause or promote existing coronary heart disease. Rapid walking at a rate of four miles per hour,

however, does not cause an increase in factor VIII or platelets, and the stickiness of platelets is slightly reduced. Therefore, walking two to three miles daily remains the best exercise.

VII. CLINICAL STUDIES OF EXERCISE AND HEART DISEASE

Millions of North Americans participate in regular exercise programs. This is a major achievement motivated by various advertisements and literature and the desire to feel fit and well and to possibly to stay alive longer. A few studies have suggested that cardiac death is more common in sedentary individuals than in the physically active, but further analysis of these studies revealed major defects in methodology and interpretation. Published studies on exercise and the risk of coronary heart disease lack standardization of the diagnosis of coronary heart disease, information on the effects of associated risk factors, and reliable evaluation of recreational or occupational physical activity.

Below are a number of studies that address exercise and its relation to cardiac disease.

A. San Francisco Longshoremen

To assess the role of physical exertion in relation to risk of fatal heart attack, the 1951–1972 work experience of 6351 San Francisco longshoremen was studied. Among men age 35–54 there were 24 heart attack deaths in those engaged in heavy work, 37 deaths in men classified as doing moderate work, and 28 deaths in those engaged in light work. Thus, there was no difference in the death rates in men age 35–54.

Among men age 65–74 there were 8 deaths in men engaged in heavy work six months prior to death, 9 deaths in those engaged in moderate work, and 275 deaths in those engaged in light work six months before death. Each man who had a fatal heart attack was classified in the job category that he held six months before death.

This study is controversial because of errors in methodology. Men 64–75 are usually engaged mainly in light work activity and death is expected in this age group. We know that the 275 men over 64 who died were engaged in light work six months prior to death, but the study does not indicate how many engaged in light work and what their activity level was during age 35–64. There may be health reasons why these men engaged in light work.

B. London Bus Drivers

A study done in 1966 showed that London bus drivers had a slightly higher incidence of heart attacks than London bus conductors, but other risk factors confounded the analysis. For example, from the outset, the bus drivers were heavier with a higher blood pressure and blood cholesterol than bus conductors and were, therefore, at higher risk. These risk factors were probably more important than job activity classification.

In a seven-country collaborative study, moderately active Finns had a 2-1/2 times higher incidence of coronary heart disease than the least active and the most active Finns. Confounding factors in this study included a high incidence of elevated blood cholesterol, which may have modified the effects of increased physical activity.

It is worth noting that in Finland there is a high occupational level of physical exertion, yet coronary heart disease mortality is very high. Individuals in Finland, consume a high-saturated fat diet, and although they have remarkably high levels of HDL (good) blood cholesterol, the incidence of coronary artery disease is higher than in most countries worldwide.

C. University Alumni

In a study of 17,000 male university alumni, 2000 kcal of exercise per week slightly reduced the risk of coronary heart disease. Vigorous sports, climbing stairs, and walking to obtain a minimum of 500 kcal of exercise per week appeared to be necessary to obtain a reduced coronary artery disease risk. In the Harvard Alumni Health Study, the trend of reduced coronary artery disease risk with increasing levels of walking was not significant.

D. Australian Study

An Australian group studied 370 men who took part in a twice-weekly exercise program with one hour of calisthenics, volleyball, and running who improved physical fitness by 17%. This program was continued for five years, and even though the men felt physically fit, there was no reduction in blood cholesterol, weight, or blood pressure. Morris et al. analyzed the exercise habits of 18,000 sedentary male office workers. Those with vigorous leisure time activity had about a 50% reduction in heart attacks. The 18,000 men were asked on a Monday morning to complete a record indicating their level of physical activity on the preceding Friday and Saturday. In this study, vigorous exercise included sports and recreation, i.e., singles tennis, swimming, jogging, running, walking at a

rate of four miles per hour and cycling fast uphill, and very heavy work. At the end of 8-1/2 years, there were 24 (1.1%) fatal and 42 (2%) nonfatal heart attacks in the vigorous-exercise group of 2200 men, but 411 (2.4%) fatal and 570 (3.4%) nonfatal heart attacks in the nonvigorous-exercise group of 16,800 men. Thus there was about a 50% reduction in heart attacks attributed to the good effects of vigorous exercise. These results are statistically significant. However, selection of individuals may have created a bias and the study can be criticized.

Marathon running does not offer any guarantees, and it is not believed to be as protective as some enthusiasts would have us believe. In four of seven marathoners who had completed a total of 64 marathons and died, autopsy showed severe atherosclerosis of their coronary arteries. The bad news is that severe coronary atherosclerosis is the most common cause of death, even among marathoners.

E. Tanasescu et al.

Study question: This study is carried out to assess the amount, type, and intensity of physical activity in relation to risk of coronary artery disease among men.

Methods: A cohort of 40,444 American men enrolled in the health professionals follow-up study and were followed for 12 years. Incidence of myocardial infarction during this time was noted. Men aged 40–75 years answered a detailed questionnaire. Follow-up questionnaires were sent every two years to identify newly diagnosed cases of coronary artery disease.

Results: Men who ran for an hour or more per week had a 42% risk reduction compared with men who did not run ($p = 0.001$ for trend). Men who trained with weights for 30 minutes or more per week had a 23% risk reduction, but this reduction claimed by the authors of the study was actually clinically nonsignificant ($p = 0.03$). In clinical medicine a value $p < 0.02$ is considered significant and meaningful in terms of lives saved. A half hour per day or more brisk walking was associated with an 18% risk reduction.

The self-report of physical activity is a limitation of the study. The authors claim that walking pace was associated with reduced coronary artery disease risk independent of the number of walking hours is not valid.

F. Albert et al.

Study question: Does vigorous exercise increase or decrease the risk of sudden cardiac death (SCD)?

Methods: By means of a questionnaire, information on the frequency of vigorous exercise was obtained from

21,481 male physicians aged 40–84 participating in the Physician's Health Study. Strenuous exercise was defined as exercise vigorous enough to cause sweating. Each exercise session was assumed to be associated with 30 minutes during and 30 minutes after exercise exposure time to sudden death.

Results: There were 122 sudden cardiac deaths during 12 years of follow up with an incidence of 1 death per 19 million person-hours. The majority of physicians reported engaging in vigorous exertion two to four times per week. Among men who engaged in vigorous exercise less than once a week there was a 74-fold increase in the risk of sudden death during vigorous exercise. Men who engaged in vigorous exercise at least five times a week had an 11-fold increase in risk.

Conclusion: The authors of this study concluded that there appears to be a 17-fold increase in risk of SCD during strenuous exercise, and this risk is attenuated by habitual vigorous exercise. This study was not able to show a net beneficial effect of vigorous exercise on SCD. The study conclusion is limited, because the baseline data on the frequency of exercise were not dated during 12 years of follow up; thus, the conclusions should not be considered definitive.

G. Frolkis et al.

Study question: Would the presence of ventricular ectopy after exercise predict an increased risk of death better than ventricular ectopy during exercise?

Methods: In this study, 29,244 patients were referred for exercise testing aged 56 ± 11 years without a history of heart failure, valve disease, or arrhythmia. Ventricular ectopy was defined as the presence of seven or more ventricular premature beats per minute, ventricular couplets, triplets, or ventricular tachycardia.

Results: There were 945 (3%) patients who had ventricular ectopy only during exercise, 589 (2%) only during recovery, and 491 (2%) during both exercise and recovery. After propensity matching for confounding variables, frequent ventricular ectopy during recovery predicted an increased risk of death ($p = 0.003$), but frequent ventricular ectopy during exercise did not ($p = 0.53$).

H. Vigorous Exercise and Risk

The relationship between vigorous exercise and the risk of a fatal or nonfatal heart attack has long been the subject of controversy. Reportedly, vigorous exercise can precipitate SCD in healthy individuals. The risk of sudden death is higher in men with low levels of habitual

activity who engage in unusual vigorous exercise. Even in men who were accustomed to vigorous activity, however, the risk of SCD was moderately increased during high-intensity exercise.

The authors only analyzed nine deaths. It would be foolhardy to make any generalizations from such a study. This study was done in King County, Washington, an area containing 1.25 million people. Only nine cardiac arrests during vigorous exercise occurred in 14 months — five in men with low levels of habitual activity and four in men with high levels of activity. This study should not influence the medical profession or public except to emphasize that jogging is relatively safe and cardiac arrest is very rare. However, sedentary individuals should not rush out and do vigorous exercises without engaging in levels of gradual activity. In addition, in Rhode Island during a six-year period, only one jogging death occurred per year for every 6720 joggers. This is a very low death rate, but it is higher than expected. Despite our defense of jogging for those who love it, we must emphasize that all studies show a much higher incidence of heart attacks during exercise than would be expected by chance. Heart attack is the most common cause of death during exercise.

I. Perspective

The death of exercise enthusiast James Fixx is a good example of nonprotection by exercise. In his early 30s he recognized that he was at high risk because his family history was strong for heart attacks before age 50. A daily run of 5–10 miles for more than 15 years did not protect him from the silent killer. Note that during jogging and running the systolic blood pressure may be slightly or moderately increased. The combined increase in blood pressure and high-velocity blood flow may, over a period of years, increase atherosclerosis.

Strenuous exercise can precipitate death in individuals who have a very rare heart muscle problem called obstructive cardiomyopathy. The division (septum) between the right and left ventricle becomes extremely thick for reasons unknown and obstructs the blood flow from the left ventricle into the aorta. This condition explains the rare sudden death that occurs in some athletes under the age of 30. This obstructive heart muscle problem is fortunately very rare and is easy to exclude. This is done by a doctor listening with a stethoscope and with added tests such as an ECG and an echocardiogram. (See chapter entitled *Cardiomyopathy*.)

All patients with known heart disease or with symptoms that suggest heart disease — pain or discomfort in the chest, throat, jaw, or arms during activity; shortness of

breath; palpitations (fast, pounding heartbeats or skipped heartbeats) — should have an assessment by a doctor and a stress test before engaging in moderate or vigorous exercise. Patients with previous heart failure or marked heart enlargement should engage only in moderate exercise such as walking or its equivalent. Exercise is well known to precipitate heart failure in such individuals; therefore, further advice from your doctor is necessary if you want to do exercise other than the equivalent of walking one mile daily.

VIII. INJURIES DURING JOGGING

The up and down motion of jogging causes tendon, muscle, and joint injuries. In one survey, about 1800 injuries occurred in 1650 amateur runners. Injuries included: (1) Achilles' tendonitis where the heel and the tendon become painful; (2) shin splints where the muscles at the front of the leg (frontal compartment syndrome) become painful and swollen; (3) painful knees with inflammation of the fluid-filled sac (bursitis), strain on ligaments, or painful knee caps (chondromalacia patellae); (4) painful feet with inflammation of the sole of the foot, plantar fasciitis, and trauma to the bones of the foot; and (5) exacerbation of arthritis of the hips, knees, and ankles. Patients with arthritis must not jog. Women are more susceptible to knee injuries or stress fractures in the pelvis, and in some, osteoporosis (loss of bone) may develop.

If you must jog, purchase good running shoes, exercise the ankle joint, and warm up properly to prevent injuries. Despite such precautions, injuries are very common among joggers.

IX. HOW TO START AN EXERCISE PROGRAM

A. General Advice

If you are under 40, do not have arthritis or moderate or severe hypertension, and feel in good health, you can engage in all activities including vigorous exercise as frequently as you desire. Regardless of age, it is wise to do 5–10 minutes of warm-up exercises before going on to vigorous exercises. Warm-up exercises prevent the pulse and blood pressure from increasing abruptly, thereby putting sudden strain on the heart. You should engage for one to two weeks in moderate exercise such as walking one to two miles or jogging one mile daily before considering vigorous aerobic exercise such as running two to five miles

three or four times weekly. If you are under 35, there is very little reason to check the pulse rate. If you feel your heart pounding away very rapidly, then slow your pace. For those engaged in competitive sports: We are in agreement with other experts that running is perhaps the best exercise for those who require the stamina to perform well. The swimmer, boxer, or cyclist should jog to develop stamina and medium weight training to strengthen other muscles. Similarly, the runner should engage in other exercises, especially swimming and cycling.

For individuals over age 40 in good health, the following advice is given. Walking two miles in a half hour, swimming, and cycling are excellent exercises. They are efficient and safe as well as economical. Walking four miles in 60–70 minutes and climbing six flights of stairs twice daily can produce cardiovascular conditioning. You do not require special equipment and you do not have to travel to a gym, ski slope, or racquet club. Walking two miles quickly burns up as many calories as jogging one mile. Jogging exercises the legs but not the important quadriceps muscles at the front of the thighs. Walking up three to six flights of stairs twice daily or cycling will strengthen the quadriceps and strong quadriceps strengthen and stabilize the knees.

If you are physically inactive at work and at home for more than six months, you should start very slowly. Start with daily or alternate-day 10-minute stretching exercises, moving all the joints and the muscles of the upper and lower limbs as well as the trunk. Follow with 20 minutes of brisk walking (a little more than a mile), and then cycle for 5–10 minutes. A stationary bicycle or treadmill is a good investment.

After about four weeks of this mild exercise, increase the walk to 30 minutes and cycle for 10–15 minutes. After one month of this routine, if you feel well with no abnormal symptoms such as chest, throat, or arm discomfort, very fast heartbeats, or shortness of breath, you can freely engage in your favorite racquet sport. Swimming is well

known to be an excellent conditioner as well as pleasurable exercise. If you wish to move to vigorous exercise, you should have a medical checkup. It is a pity that many individuals commence regular jogging or other exercise at 18 and stop at 38. For some it is a pleasure and for others an obsession that imposes stress. Those who love jogging should obviously continue, especially through the vulnerable years between 35 and 55.

B. Heart Rate Maximum and Training Range

Learn to take your heart rate and determine your maximal and submaximal heart rate. During your medical checkup, your doctor will show you how to feel the pulse at the wrist (radial artery) or the carotid artery in the neck. Count the pulse beat for 10 seconds and multiply the number by 6 to get the heart rate per minute.

The heart rate increases to high levels with vigorous exercise, and these upper limits have been established by doctors engaged in exercise conditioning programs. Several charts have been designed by experts and used in different countries. At age 20 the highest heart rate that the normal heart can achieve is between 200 and 220 beats per minute, and this is called the maximum attainable heart rate (Table 1). To be safe, doctors advise that you should not exceed 85% of this maximal value, that is, about 170 beats per minute if you are young and healthy. During the first few weeks of training, keep the heart rate at about 70% maximum, that is, about 140 beats per minute, and increase the exercise to 85% if you are under age 30. If you are in good health, it is safe to exercise so that your heart rate reaches 70–85% of your maximal value and to keep it at this rate for about 20 minutes. After six to eight weeks of strenuous exercise, you should achieve physical and cardiopulmonary conditioning. At age 40 your maximum heart rate should be approximately 220 – 40, or 180, and your training range, your “target zone,” from

TABLE I
Age-Related Maximum Attainable Heart Rates and Training Range

Age	20	25	30	35	40	45	50	55	60	65
Maximum Heart Rate	200	195	190	185	180	175	170	165	160	155
(220-age)										
85%	170	165	161	157	153	148	144	140	136	131
Training Zone										
70%	140	136	133	130	126	122	119	115	112	108

125 to 150. Your pulse counted for 10 seconds should be a minimum of 20 and a maximum of 25 beats. You do not necessarily need to reach and maintain the target zone, as some have claimed, to obtain conditioning or the training effect.

Maximum rates and training ranges are given in Table 1. Individuals over age 40 who have not engaged in strenuous exercise in the last two years or who have a family history of heart attacks before age 50, blood cholesterol greater than 220 mg, or mild hypertension are advised to have a stress test before starting vigorous exercise.

X. EXERCISE STRESS TEST

Graded exercise testing introduced by Robert Bruce five decades ago remains an important diagnostic test for coronary artery disease. When coronary arteries become obstructed by atheromatous plaques, the supply of blood to the heart muscle becomes deficient and the muscle shows signs of ischemia that can be detected by the ECG. Ischemia is defined as a temporary lack of blood and oxygen to an area of cells for example the heart muscle, usually due to severe obstruction of the artery supplying blood to this area of muscle. Thus, the term ischemic heart disease is often used by physicians as it is the manifestation of coronary artery disease.

A stress test involves walking on the treadmill or cycling while your ECG is continuously recorded. The ECG terminals are taped onto your chest. Walking on the treadmill is easier if you wear running shoes or other comfortable flat shoes. The treadmill speed and its inclination are programmed to increase every three minutes so that you walk faster up a grade and are jogging by the 10th minute. Healthy individuals are exercised to 90% of their maximal heart rate. The test is discontinued if chest or leg pain, fatigue, or shortness of breath develops or if the ECG shows insufficient oxygen to the heart muscle. The blood pressure is taken every three minutes, and the systolic blood pressure usually rises by 20–40 mmHg. A 40-year-old who is physically fit with good cardiopulmonary condition can usually exercise for 10–12 minutes, reaching a heart rate of 160–180 beats per minute without having undue shortness of breath. The test is completed by about 2 minutes of slow walking to cool down before the treadmill is turned off.

A well-conditioned 35-year-old athlete's heart rate may increase only to 140 beats per minute during 12 minutes of such exercise. On resting, the heart rate should fall quickly to under 100 per minute within one to four

minutes and to less than 70 beats within two to three minutes. During the recovery phase the ECG continues to be recorded because abnormalities caused by ischemia may be detected at this stage such as ischemic changes, premature beats, and arrhythmias.

The electrocardiographic hallmark of exercise-induced myocardial ischemia is depression of the ST segment. A horizontal or down-sloping ST segment depression equal to or greater than 1 mm in two or more leads is diagnostic. If this electrocardiographic change is noted at low levels of exercise, for example, less than four minutes on the treadmill, or at slow heart rates like less than 120 beats per minute, severe obstructive coronary artery disease is usually present.

Diagnostic and prognostic variables during exercise or recovery include:

- ST segment depression >1 mm, horizontal or down-sloping
- ST segment elevation in leads lacking Q waves
- Chest pain and angina, relieved immediately by cessation of the exercise (within one to two minutes or relief with nitroglycerin)
- Inadequate blood pressure response or inadequate heart rate response (chronotropic incompetence); blood pressure and heart rate should increase
- Presence of ventricular arrhythmias

During the recovery phase important information may be obtained to point to the diagnosis of ischemic heart disease, and this could be most useful when testing if the exercise phase reveals no abnormalities. Diagnostic points include ST segment depression greater than 1 mm and delayed slowing of the heart rate.

Monitoring of the heart rate during the recovery period adds substantially to the value of exercise stress testing. Studies indicate that a delay in the decrease in the heart rate after exercise may result from inadequate reactivation of vagal tone. This predicts a poor outcome with a quadrupling of the risk of death over the next six years. The rate at which the heart rate decreases after exercise is a reflection of the level of the individual's level of physical fitness.

The appearance of high-grade ventricular arrhythmias during the recovery time appears to predict subsequent mortality better than the occurrence of ventricular arrhythmias during exercise. The appearance of ventricular arrhythmias during recovery appears to be due to inadequate vagal reactivation. Figure 4 shows the electrocardiographic tracings from a patient before, during, and after exercise with the presence of delayed slowing of the heart rate and a malignant ventricular arrhythmia.

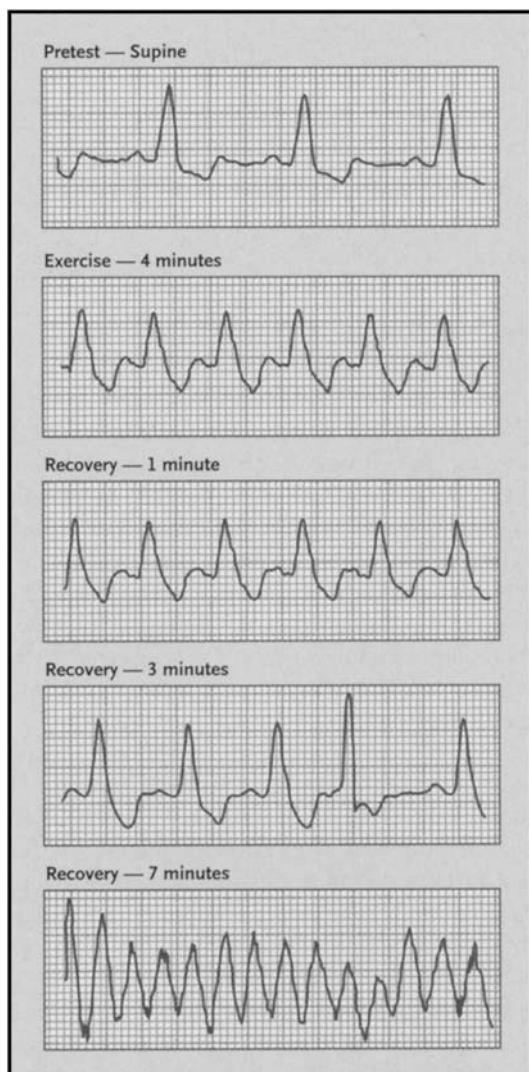

FIGURE 4 Series of electrocardiographic tracings (lead V₁) from a patient before, during, and after exercise. During the recover period there was delayed slowing of the patient's heart rate and the development of fatal ventricular fibrillation. (Tracings courtesy of Dr. Michael S. Lauer.) (From Curfman, G.D., and Hillis, L.D. (2003). A new look at cardiac exercise testing, *N. Engl. J. Med.*, 348(9), 776.)

XI. CONCLUSION

We strongly recommend regular, moderate exercise for healthy individuals and those with coronary or mild valvular heart disease. Fitness makes one feel like living and confers a sense of well-being. If you are relatively fit, you can enjoy your favorite sport with better breathing capabilities and without feeling your heart pounding. If you are fit, you are not likely to be overweight, your clothes fit you better, and you feel and look better. We

strongly recommend regular, moderate exercise to achieve a state of "relative fitness."

We recommend vigorous exercise to those who are healthy and already fit. A fit heart idles at a slower speed. A heart that beats slower allows better filling of normal or partially obstructed coronary arteries. There is no scientific proof or adequate evidence, however, to suggest that vigorous exercise will make you live longer. If you are over age 40, mainly sedentary, and engage in occasional mild exercise, do not start vigorous exercise without having a medical check or stress test. Start with walking one to two miles daily, slowly adding cycling, swimming, or similar exercise. Avoid vigorous exercise until you have done more than two months of daily moderate exercise.

Vigorous exercise in previously inactive individuals over age 35 carries a high risk of fatal or nonfatal heart attacks or sudden death. Therefore, do not rush to get superfit. Get fit slowly over three to six months, remembering that fitness is a relative term — fit to do what?

In addition, we emphasize that simple exercises such as walking two miles in a half hour or when possible four miles in an hour, climbing stairs, or peddling a stationary bicycle for 15 minutes are excellent, safe exercises. Walking is always helpful and "never" causes a heart attack. It does not increase blood pressure, instead it improves circulation in the legs and may have a favorable influence on blood clotting. Therefore, if you walk, you may win the race.

Exercise has important benefits, but it cannot be expected to halt the progression or complications of coronary artery disease, and attention to aggressive control of known risk factors is necessary. Exercise prescriptions for patients who have heart disease, especially coronary heart disease, are discussed in the chapter Heart Attacks.

BIBLIOGRAPHY

- Adams, V., Linke, A., Kränkel, N. et al. Impact of regular physical activity on the NAD(P)H oxidase and angiotensin receptor system in patients with coronary artery disease, *Circulation*, 111:555–562, 2005.
- Albert, C. M., Mittleman, M. A., Chae, C. U. et al. Triggering of sudden death from cardiac causes by vigorous exertion. *N. Engl. J. Med.*, 343:1355–61, 2000.
- Booth, F. W., and Tseng, B. S. Exercise. *Encyclopedia of Human Biology*. Academic Press, San Diego, CA, 1997, p. 853.
- Cole, C. R., Blackstone, E. H., Pashkow, F. J. et al. Heart rate recovery immediately after exercise as a predictor of mortality. *N. Engl. J. Med.*, 341:1351–7, 1999.
- Curfman, G. D., and Hillis, D. A new look at cardiac exercise testing. *N. Engl. J. Med.*, 348:775–76, 2003.
- Frolkis, J. P., Pothier, C. E., Blackstone, E. H. et al. Frequent ventricular ectopy after exercise as a predictor of death. *N. Engl. J. Med.*, 348:781, 2003.

- Kraus, W. E., Houmard, J. A., and Duscha, B. D. Effects of the amount and intensity of exercise on plasma lipoproteins. *N. Engl. J. Med.*, 347:1483-92, 2002.
- Lakka, T. A., Venalainen, J. M., Rauramaa, R. et al. Relation of leisure time physical activity and cardiorespiratory fitness to the risk of acute myocardial infarction in men. *N. Engl. J. Med.*, 330:1549, 1994.
- Marsh, S. A., and Coombes, J. S. *Exercise and the Endothelial Cell*, 165-169, 2005.
- Milvey, P., and Siegel, A. J. Physical activity levels and altered mortality from coronary heart disease with an emphasis on marathon running; a critical review. *Cardiovasc. Rev.*, 2:233, 1981.
- Morris, J. N., Hagan, A., Patterson, D. C. et al. Incidence and prediction of ischemic heart disease in London busmen. *Lancet*, 11:553, 1966.
- Paffenbarger, R. S., Jr., Wing, A. L., and Hyde, R. T. Physical activity as an index of heart attack risk in college alumni. *Am. J. Epidemiol.*, 108:161, 1978.
- Siscovick, D. S., Weiss, N. S., Fletcher, R. H. et al. The incidence of primary cardiac arrest during vigorous exercise. *N. Engl. J. Med.*, 311:874, 1984.
- Taffet, G. E., Holtz, R. W., and Tate, C. A. Exercise and cardiovascular function. *Encyclopedia of Human Biology*, Academic Press, San Diego, CA, 1997, p. 865.
- Tanasescu, M., Leitzmann, M. F., Rimm, E. B. et al. Exercise time and intensity in relation to coronary heart disease in men. *JAMA*, 288:1994-2000, 2002.
- Thompson, P. D., Funk, E. J., Carleton, R. A. et al. Incidence of death during jogging in Rhode Island from 1975 through 1980. *JAMA*, 247:2535, 1982.

Gene Therapy

- I. Strategies
- II. Clinical Application
- III. Clinical Trials
- IV. Adverse Outcomes

GLOSSARY

angina pectoris short duration, recurrent chest pain or pressure often accompanied by feelings of suffocation and impending doom; most frequently associated with lack of blood and oxygen to the heart muscle.

arterioles small branches of arteries.

atherosclerosis same as atheroma, raised plaques filled with cholesterol, calcium, and other substances on the inner wall of arteries that obstruct the lumen and the flow of blood; the plaque of atheroma hardens the artery, hence the term atherosclerosis (sclerosis = hardening).

capillaries fine, thin-walled blood vessels that branch from arterioles and feed the tissues and cells with blood and fluids.

ischemia temporary lack of blood and oxygen to an area of cells, for example, the heart muscle, usually due to severe obstruction of the artery supplying blood to this area of cells.

myocardial infarction death of an area of heart muscle due to blockage of a coronary artery by blood clot and atheroma; medical term for a heart attack or coronary thrombosis.

myocardium the heart muscle.

ANGINA PECTORIS IS A FRUSTRATING PROBLEM for both the patient and the cardiologist. It is refractory to optimal medical therapy and not amenable to revascularization procedures that include percutaneous coronary interventions (PCI) such as balloon angioplasty with intracoronary stents and coronary artery bypass graft (CABG) surgery. Alternative strategies for improving blood flow to the myocardium include transmyocardial laser revascularization, but it has not proved successful. Gene therapy including the use of angiogenic peptides is another possible therapy.

A major goal of gene therapy and the use of antigenic peptides is the production of therapeutic angiogenesis, or functional new blood vessel growth in the myocardium. It is hoped that this should improve myocardial oxygen supply. Gene therapy has yet to show convincing efficacy in humans and the therapy may even be harmful.

Angiogenesis must be distinguished from arteriogenesis. Angiogenesis is the formation of new vessels that lack a tunica media; arteriogenesis describes nature's phenomenon of newly formed arterioles with fully developed tunica media. A prime example of arteriogenesis is collateral vessels observed angiographically in patients with severe obstructive coronary artery disease (ischemic heart disease) or long-standing peripheral vascular disease. An example of angiogenesis is the formation of thin-walled fragile capillaries along the borders of a myocardial infarct. The formation of strong arterioles with a normal media is an acceptable goal that may never materialize.

I. STRATEGIES

Gene therapy involves either the delivery of whole active genes (gene transfer) or the blockade of native gene expression by transfection of cells with short chains of nucleic acids (oligonucleotides). These short, single-stranded DNA molecules are used as drugs to target the inactivation of mRNA- or DNA-binding proteins.

Manipulation of gene activity or gene expression is achieved by introducing foreign DNA into target cells where subsequently it is expressed in a process known as transduction or transfection (see Fig. 1). Systems include recombinant viral vectors that permit relatively competent insertion of genetic information and oligonucleotides that are used to modify native gene expression. Gene blockade may also be achieved by the use of ribozymes, segments of rRNA that can act as enzymes to destroy certain sequences of target mRNA. A third type of gene blockade involves the use of gene regulatory proteins known as transcription factors, which regulate gene expression by binding to chromosomal DNA. This process activates an adjacent

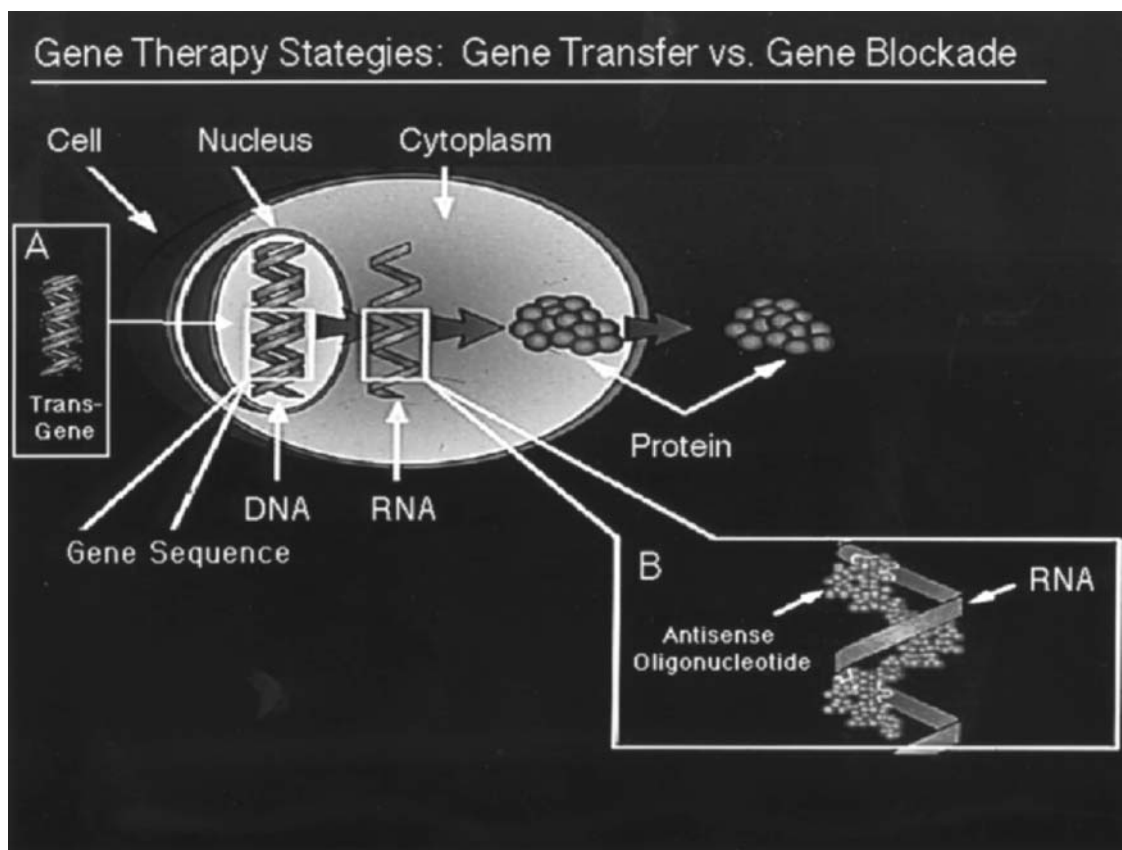

FIGURE 1 Gene therapy strategies. (A) Gene transfer involves delivery of an entire gene, either by viral infection or by nonviral vectors, to the nucleus of a target cell. Expression of the gene via transcription into mRNA and translation into a protein gene product yields a functional protein that either achieves a therapeutic effect within a transduced cell or is secreted to act on other cells. (B) Gene blockade involves the introduction into the cell of short sequences of nucleic acids that block gene expression, such as antisense ODN that bind mRNA in a sequence-specific fashion and prevent translation into protein. (From Ehsan, A., Mann, M.T., and Dzan, (2001). *Essential Cardiology: Principles and Practice* (Rosendorff, C., Ed.), Philadelphia: W.B. Saunders, p. 781. With permission.)

gene. Synthetic DNA decoys prevent binding of transcription factors to the promoter site of many genes involved in cell proliferation. This process inhibits cell cycle progression, potentially leading to inhibition of neointimal hyperplasia and may cause reduction in stenosis of venous bypass grafts.

The recombinant virus particles used as gene transfer vectors do not have the ability to replicate. Table 1 lists gene therapy vectors. Recombinant adenoviruses are commonly used viral vectors and unfortunately achieve gene expression for only a few weeks after infection. The ventricular myocardium appears to be receptive to the introduction of foreign genes, and gene transfer has been achieved using direct injection into the myocardium or intracoronary infusion of material that has been genetically engineered in cell culture.

Small, circular DNA pieces called plasmids are simple tools of molecular biology. They lack viral elements that substantially reduce the risk of toxicity and immune

reactions. Plasmids are taken up by most cells, however, and promote low gene transfer effects. They are also unprotected against cellular defense mechanisms. Nevertheless they appear to be safe, although their effects appear to be transient.

There is ongoing development of an artificial virus that may incorporate the plasmid necessary to confer effective translocation into the cell at high efficiency. Third generation lentiviruses are also being tested.

II. CLINICAL APPLICATION

Gene therapy remains a daunting task. Table 2 lists the pertinent cardiac conditions. There has been no clinical trial for heart failure or transplantation. Presently improved oxygen supply to a myocardium deprived of oxygen because of atheromatous coronary artery obstruction is the goal. Success has thus far not been obtained. In addition

TABLE I
Gene Therapy Vectors

Vector	Advantages	Disadvantages
Viral		
Adenovirus	Efficient transduction of both dividing and nondividing cells; high titers	Host immune response limits longevity of gene expression; 8-kb insert size limitation; complementing cell lines required; lack of transduced cell specificity
Adeno-associated virus (AAV)	Efficient transduction of both dividing and nondividing cells; less pathogenic; sustained transgene expression; possible target-specific integration	5-kb insert size limitation; moderate titers
Retrovirus	Long-term transgene expression if integration into host DNA occurs	Low transduction efficiency in nondividing cells; insertional mutagenesis possible; packaging cell line required
Lentivirus	Long-term transgene expression in dividing and nondividing cells	HIV reactivation risk; low titers; insertional mutagenesis possible
Hybrid viruses	Efficiency of adenovirus transduction; low immunogenicity and sustained transgene expression of AAV or retrovirus	Complexity of construction, packaging, and high titer production
Nonviral		
Naked plasmid DNA	Safe; no transgene size limitation; simple methodology; low immunogenicity	Low efficiency of transfer and gene expression
DNA-liposomes	Safe; no transgene size limitation; flexible composition; wide cell range of transfection	Moderate efficiency of transfer; transient gene expression
Protein-DNA complex	Cell specificity determined by protein; no transgene size limitation	Intermediate efficiency of transfer and gene expression in vivo; may be immunogenic
Artificial Virus		
Sendai virus-liposome complex	Efficient transfer of both transgenes and oligonucleotides; low toxicity and immunogenicity	Extensive preparation required
Adenovirus-liposome complex	Increased efficiency of liposome-mediated transfer	Adenoviral construct needed; lower efficiency than adenovirus-mediated transduction

AAV, adeno-associated virus; HIV, human immunodeficiency virus.

From Antman, E.M. Ed. (2002). *Cardiovascular Therapeutics, 2nd ed.*, Philadelphia: W.B. Saunders, p. 1027

TABLE 2
Cardiac Gene Therapy

Clinical disease	Pathobiology	Gene augmentation	Antigene target
Myocardial ischemia	Preconditioning	PKG, MAPK, iNOS, adenosine A(1) receptor	
	Myocyte apoptosis	IGT-1, Akt, PI 3-kinase, Bcl-2, FLIP, IAPs, gp 130	Fas ligand, p53, p38
	Angiogenesis	VEGF, FGF, angiopoietin, engineered angioblasts	Endostatin, angiostatin
Heart failure	Impaired contractility	SERCA2a, PKA IGF-1, Akt,	Phospholamban,
	Myocyte apoptosis	PI 3-kinase, Bcl-2, FLIP, IAPs, gp 130	β ARK1 Fas ligand, p53, p38
Cardiac transplant rejection	Host immune response	Fas ligand, IL-4, IL-10, soluble receptors to proinflammatory mediators (e.g., TNE, interferon- γ)	NF κ B, IL-8, ICAM, VCAM

β ARK1, β -adrenergic receptor kinase; FGF, fibroblast growth factor; FLIP, Fas-associated death domain-like IL-1 β -converting enzyme-inhibitory protein; IAP, inhibitor of apoptosis; ICAM, intercellular adhesion; IGF, insulin-like growth factor; IL, interleukin; iNOS, inducible nitric oxide synthase; MAPK, mitogen-activated protein kinase; PKA, protein kinase A; PKC, protein kinase C; SERCA, SR calcium ATPase pump; TNE, tumor necrosis factor; VCAM, vascular cell adhesion molecule; VEGF, vascular endothelial growth factor.

From Rosendorff, C., Ed. (2002). *Essential Cardiology*, Philadelphia: W. B. Saunders, p. 1030.

this goal is fraught with danger, because angiogenesis may increase plaque growth and decrease the thickness of the fibrous plaque which is protective and fragile. New vessels within the plaque are prone to rupture causing ultimate plaque rupture and severe cardiac events, see Section IV.

The most interesting future goal is that gene therapy interventions may be capable of increasing HDL cholesterol levels and lowering blood triglycerides. This could be a most valuable addition to our therapeutic armamentarium, because the lifesaving statins that lower LDL cholesterol do not significantly increase HDL levels.

The cholesterol ester transfer protein (CETP) mediates the exchange of cholesteryl ester in HDL for triglyceride in very low-density lipoprotein (VLDL). Thus, CETP appears to reduce HDL and cause progression of atheroma formation; a pharmacologic inhibitor supports this hypothesis and gives hope that an anti-gene approach to this target may be possible.

III. CLINICAL TRIALS

A. The Euroinject

One trial was presented at the American College of Cardiology scientific session in March of 2003. This multinational study, however, involved only 80 patients. Patients with end-stage refractory angina with severe ischemic heart disease not amenable to all forms of revascularization therapy were randomized. Patients with recent myocardial infarction or proliferative retinopathy were excluded.

Direct myocardial injections of gene therapy with phVEGF-A165 (vascular growth factor) were tested. Ten myocardial injections of a plasmid solution was the therapy. After three months' follow up using various tests there was an increase in blood flow and new vessels observed. Angina symptoms showed a modest improvement. The improvement in myocardial perfusion observed needs further studies for confirmation. The investigators agreed that there was a large placebo effect. No major adverse effects were noted in the short-term study.

B. Study in Patients with Disabling Intermittent Claudication

Regional angiogenesis with vascular endothelial growth factor in peripheral arterial disease (RAVE) is a phase to randomized double-blind controlled trial in patients with disabling intermittent claudication. This well-conducted study showed no improvement in claudication and other parameters after 26 weeks of therapy. This is the largest

such trial to date and follow up indicates no significant differences in treatment versus placebo.

C. Adenovirus Gene Therapy Trial (AGENT) Trial

Sixty patients received direct injection of recombinant adenovirus 5 FGF-4 and 19 patients received placebo. Follow-up treadmill tests at 12 weeks showed a greater than 30% increase in exercise tolerance time as compared with placebo group. But the placebo group showed marked improvement from baseline, indicating the need for double-blind placebo-controlled trials.

D. Small Trials

A trial of 32 patients who received AdVEGF121 was undertaken. Thirty myocardial injections were administered during mini thoracotomy. The 32 patients received optimal medical therapy. At 26 weeks patients in the treated group exercised on average 1 minute longer before the appearance of ST segment depression, and improvement from 4 minutes to 5 minutes. This one-minute improvement shown on electrocardiographic testing was proclaimed significant by the investigators, despite the fact that there were two postoperative deaths in the treated group and that this treatment was an absolute failure.

E. Initial Study

The first evidence of human vascular angiogenesis in a patient was reported by Isner et al. in 1996. Four weeks after intra-arterial gene transfer of a plasmid encoding for vascular endothelial growth factor, improvement in the ischemic leg was observed. An increase in collateral vessels at the knee and lower leg was verified by angiography, but after 5 months the patient's leg was removed below the knee because of gangrene. To date none of the over 200 well-designed, peer review human trials have demonstrated a significant and meaningful therapeutic effect.

IV. ADVERSE OUTCOMES

A. Progression of Atherosclerosis

An old pathology textbook, Muir's Pathology, (1958) states

Winternitz (1938) has shown that atheromatous patches may contain new capillaries, some of which

take origin from the intimal lining, and these delicate vessels are exposed to the fluctuations in pressure within the parent arteries. It is not surprising, therefore, that hemorrhage into such patches should sometimes follow exertion.

Hemorrhage into an atheromatous plaque causes rupture of the plaque with subsequent thrombosis and occlusion of the vessel. Microvessels within plaques have functional significance. Administration of inhibitors of angiogenesis to mice has been shown to inhibit experimentally induced atheroma formation and limit lesion expansion. Thus, it is not surprising that attempts to augment myocardial new vessel formation by gene therapy or other strategies might have adverse effects on plaque growth and plaque rupture. An inhibitory effect of angiostatin in a murine model of atherosclerosis suggests the potential proatherogenic role for angiogenesis.

Gene transfer methods have been shown to reduce smooth muscle cell proliferation and neointimal formation. The smooth muscle cells play a protective role in strengthening constitutional plaque into in the formation of a fibrous cap. Any measure that decreases smooth muscle cell proliferation is fraught with danger.

Studies have shown that there is an inverse correlation between smooth muscle proliferation and cyclin-dependent kinase inhibitors (CKIs) such as P21 and P27. Gene transfer methods that result in overexpression of CKIs reduce smooth muscle cell proliferation and neointimal formation. P1 and P27 knock-out mice given

a Western diet undergo accelerated arterial cell proliferation and atherosclerosis.

B. Other Effects

Significant clinical trial-related deaths have occurred. The potential for vector-induced cytotoxicity remains. Proliferative retinopathy and retinal hemorrhage occur and caution is warranted.

BIBLIOGRAPHY

- Cappell, D. F. In *Muir's Textbook of Pathology*, seventh ed. Edward Arnold Ltd., London, 1958.
- Grines, C. L., Watkins, M. W., Helmer, G. et al. Angiogenic gene therapy (AGENT) trial in patients with stable angina pectoris. *Circulation*, 105:1291–7, 2002.
- Hughes, G. C., Biswas, S. S, Yin, B. et al. A comparison of mechanical and laser transmyocardial revascularization for induction of angiogenesis and arteriogenesis in chronically ischemic myocardium. *J. Am. Coll. Cardiol.*, 39:1220–8, 2002.
- Isner, J. M., Pieczek, A., Schainfeld, R. et al. Clinical evidence of angiogenesis after arterial gene transfer of ph VEGF 165 in patients with ischaemic limb. *Lancet*, 348:370–374, 1996.
- Kim, M. C., Kini, A., and Sharma, S. K. Refractory angina pectoris. Mechanisms and therapeutic options. *J. Am. Coll. Cardiol.*, 39: 933–34, 2002.
- Losordo, D. W., and Isner, J. M. Vascular endothelial growth factor-induced angiogenesis: Crouching tiger or hidden dragon? *J. Am. Coll. Cardiol.*, 37:2131–55, 2001.
- Seppo lä-Herttua, S., Markkanen, and J. E., Rissanen, T. T. Gene therapy for ischemic cardiovascular diseases: Some lessons learned from the first clinical trials, *Trends in Cardiovascular Med.*, 14:(8)295–300, 2004.

Heart Attacks

- I. Perspective
- II. Causes and Pathophysiology
- III. Door-to-Needle Time
- IV. Symptoms
- V. Physical Signs
- VI. Mimics of a Heart Attack
- VII. Ambulance Transport
- VIII. What to Expect in the Hospital
- IX. Diagnostic Tests
- X. Specific Management
- XI. Clinical Trials
- XII. Non-ST Elevation Myocardial Infarction
- XIII. Complications of Myocardial Infarction
- XIV. Heart Attack and Emotional Impact
- XV. Depression and Anxiety
- XVI. Diet After a Heart Attack
- XVII. Rehabilitation, Retirement, and Travel
- XVIII. Retirement and Travel
- XIX. Sexual Activities
- XX. Beta-Blockers
- XXI. Eplerenone (Inspra)
- XXII. Case History of a Heart Patient
- XXIII. Risk Factors and Prevention
- XXIV. Heart Attack Prevention Diet

GLOSSARY

angina chest pain caused by temporary lack of blood to an area of heart muscle cells, usually caused by severe obstruction of the artery supplying blood to this area.

arrhythmia general term for an irregularity or rapidity of the heart beat, an abnormal heart rhythm.

atheroma same as atherosclerosis, raised plaques filled with cholesterol, calcium, and other substances on the inner wall of arteries that obstruct the lumen and the flow blood; the plaque of atheroma hardens the artery hence the term, atherosclerosis (sclerosis = hardening).

ejection fraction the fraction of blood ejected from the heart into the arteries, normally this ranges from 60 to 75%; a low ejection fraction is less than 40%; often used as a marker of ventricular contractility.

heart failure failure of the heart to pump sufficient blood from the chambers into the aorta; inadequate supply of blood reaches organs and tissues.

left ventricular dysfunction poor ventricular contractility, this leads to heart failure.

preload the degree of ventricular muscle stretch present at the onset of myocardial contraction; often expressed as end diastolic volume or pressure.

venodilatation dilation of veins, as may occur during hot weather, hot baths, and by some drugs such as ACE inhibitors and nitroglycerin.

WHEN A HEART ATTACK BEGINS, THE individual is suddenly stricken by pain in the center of the chest. This pain is often unbearable and may be a pressure-like discomfort accompanied by difficult breathing, profuse sweating, and a strange frightened feeling. The cause of a heart attack in the majority of cases is a blockage of a coronary artery that feeds the heart muscle with blood containing oxygen, glucose, sodium, potassium, calcium, and other nutrients. In more than 90% of patients, the blockage has been shown conclusively to be due to a blood clot. This blood clot is often present on the surface of a partially obstructing plaque of atheroma that shows fissuring (rupture or ulceration). The blocked artery cuts off blood to a segment of heart muscle (myocardium), the cells of which die because they are deprived of the nutrients in the blood. This death of heart muscle cells is called a myocardial infarction (see Fig. 1).

A heart attack, medically called a myocardial infarction or coronary thrombosis, is a common occurrence, particularly, in young men aged 35–55. It is called the widow maker because death occurs during the attack in more than 50%. A heart attack is the most common cause of death in women age 55–85.

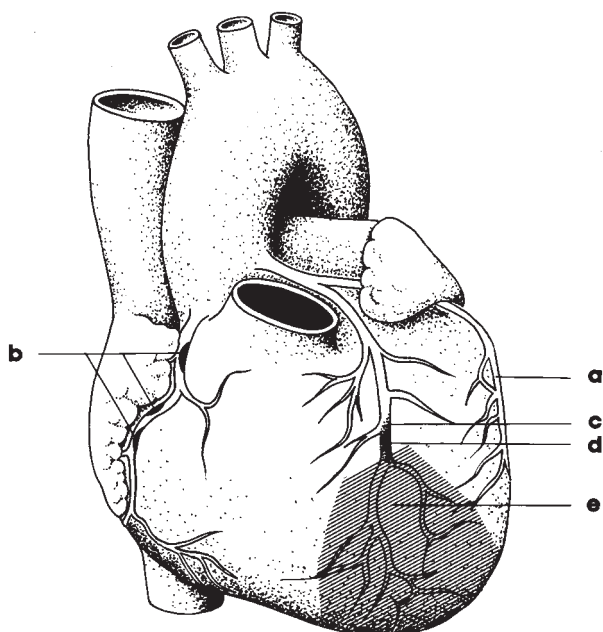

FIGURE 1 Coronary heart (artery) disease. (a) Normal coronary artery; (b) obstruction of a coronary artery by atherosclerosis causing less blood to reach the heart muscle, producing chest pain, called angina; (c) blood clot; (d) complete obstruction of a coronary artery by atherosclerosis and blood clot (coronary thrombosis); (e) damage and death of heart muscle cells, i.e., a heart attack (myocardial infarction).

I. PERSPECTIVE

More than one million patients have an acute myocardial infarction in the United States annually and more than 40% of these patients die within the first hour. Of those admitted to the hospital, approximately 15% die during hospitalization. Additionally, more than one million patients with symptoms suggestive of acute myocardial infarction are admitted annually to coronary care units. In the year 2000 more than 12 million people died because of cardiovascular disorders mainly caused by atheroma and subsequent thrombosis (atherothrombosis). It is estimated that in the year 2025 more than 24 million people will die from this disease in a world population of approximately 7.4 billion. Intensive research is required to prevent atherothrombosis rather than the management of its complications which include fatal and nonfatal heart attack, angina, heart failure, abdominal aortic aneurysm, stroke, kidney failure, and peripheral vascular disease causing intermittent claudication and gangrene of the lower limb.

Most of the research done in major institutions in the United States and in developed countries is directed at the management of complications of atherosclerotic coronary artery disease. The advent worldwide of coronary care

units in the early seventies, thrombolytic agents in the late eighties, coronary angioplasty in the eighties and nineties, and stents during the past decade have improved survival but this can be considered “a spit in the ocean expecting the tide to rise.” The development of left ventricular assist devices (that are clearly bridge to transplantation and not artificial hearts) requires considerable financial support for their development, but they will save less than 4000 lives annually worldwide. [See the chapter, Artificial heart]

II. CAUSES AND PATHOPHYSIOLOGY

The cause of a heart attack in the majority of cases is a blockage of a coronary artery by a blood clot. This clot usually occurs on the surface of a partially obstructing plaque of atheroma (see the figures in the chapter Atherosclerosis/Atherothrombosis). The surface of a plaque ruptures and the plaque contains substances that increase the clotting of blood. A clot therefore forms on the surface of the rupture and also inside the plaque. The ruptured plaque, by direct release of tissue factor and exposure of the subintima, is highly thrombogenic. Exposed collagen further provokes platelet aggregation. Some plaques, particularly those that have a high lipid content and a thin fibrous cap, are prone to rupture (see the chapter Atherosclerosis/Atherothrombosis). Considerable research has been done during the past decade on the complexity and the instability of vulnerable plaques.

Coronary angiography performed during the early hours of infarction confirms the presence of total occlusion of the infarct-related artery in over 90% of patients. It is not surprising that aspirin, through inhibition of platelet aggregation, reduces the incidence of coronary thrombosis and prevents the progression of unstable angina to thrombosis and myocardial infarction. Aspirin is particularly useful when given at the onset of chest pain produced by an infarction. However, it does not block all pathways that relate to platelet aggregation (see the chapter Antiplatelet Agents).

The increased morning incidence of acute myocardial infarction documented in several studies of the diurnal variation of infarction is related to the early morning catecholamine surges, which induce platelet aggregation. This morning incidence is also related to an increase in blood pressure and hydraulic stress, which may lead to plaque rupture (see Fig. 2). Beta-blockers have been shown in randomized clinical trials to decrease the early morning peak incidence of acute myocardial infarction and sudden death. Use of a beta-blocking agent may inhibit plaque rupture by its ability to decrease cardiac ejection velocity.

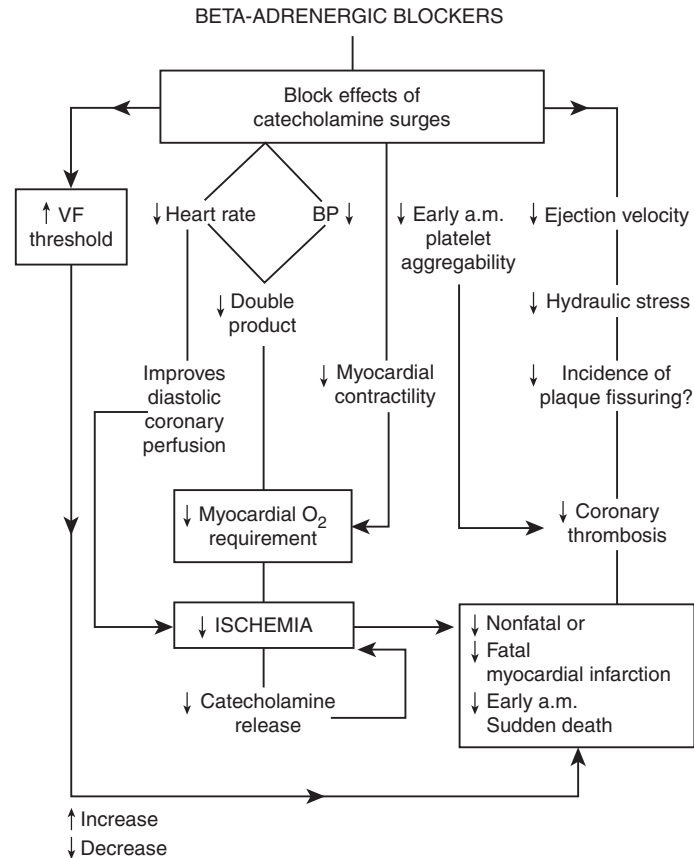

FIGURE 2 Salutary effects of beta-adrenergic blockade. (From Khan, M. Gabriel (2005). *Heart Disease, Diagnosis and Therapy*, second edition, New Jersey: Humana Press.)

This action reduces hydraulic stress on the arterial wall which might be critical at the arterial site where the atheromatous plaque is predisposed to rupture.

In approximately 10% of patients with acute myocardial infarction, rupture of fragile capillaries within the plaque occurs causing a small hemorrhage into the plaque and subsequent rupture and thrombosis. The reason for rupture of these capillaries within the plaque may be related to a surge in blood pressure caused by increased catecholamine release.

Occlusion of the coronary artery leads, in about 20 minutes, to death of cells in areas of severely ischemic tissue, which will usually become necrotic over three to six hours. Because early and late mortality are directly related to the size of the infarct, limitation of infarct size or prevention of necrosis by means of thrombolytic therapy initiated at the earliest possible moment is of the utmost importance.

The ischemic zone surrounding the necrotic tissue provides electrophysiologic inhomogeneity which predisposes the occurrence of lethal arrhythmias. These

arrhythmias are most common during the first few hours after the onset and contribute to one of the major mechanisms of sudden death that commonly occurs within the first hour of onset. Extensive myocardial necrosis is the major determinant of heart failure; papillary, septal, and freewall rupture; and cardiogenic shock in which more than 35% of the myocardium is usually infarcted and necrotic. The most effective means of reducing the extent of myocardial necrosis is administration of thrombolytic therapy, aspirin, and a beta-blocking agent within three hours of onset. For large infarctions or in those with contraindications to thrombolytic agents, the opening of the infarct-related artery with balloon angioplasty plus intracoronary stent is the most effective way to reduce necrosis. Newer intracoronary stents that have a low incidence of in-stent restenosis will revolutionize the management of acute myocardial infarction (see the chapter Stents).

In the majority of patients who have a heart attack, no precipitating factor can be identified. The individual may wonder, why today? What did I do wrong? Only

occasionally is there some circumstantial evidence that may be related to the incident; for example, excessive unaccustomed exertion or severe stress. A large fatty meal, bed rest for several months, and overwork without undue distress do not appear to be precipitating factors. No one knows when a plaque of atheroma will rupture and cause a clot. If the blood is thicker and has a greater tendency to clot than normal, the individual is obviously at greater risk of having a heart attack. Substances that cause rapid and intense clotting are released when the plaque ruptures. These substances are exposed to the flowing blood and a clot quickly forms, thus blocking the artery.

Possibly, new drugs could be produced to inhibit the clotting (thrombogenic) substances in the plaque. A pharmaceutical firm or scientists should explore this potential avenue which may produce a product that can prevent a fatal or nonfatal heart attack. The simple drug aspirin certainly helps to prevent some heart attacks and save lives, but it does not nullify the clotting properties of the ruptured plaque contents.

After a few months the area of dead heart muscle forms a well-healed scar. The size of the myocardial infarction depends on the coronary artery affected, i.e., a main vessel or a branch artery, and what part of the heart muscle it supplies (see the illustrations in the chapter on Anatomy of the Heart and Circulation). If the anterior part of the heart is involved, this is more serious than involvement of the back (inferior) part of the heart. Inferior infarction has a very good prognosis.

III. DOOR-TO-NEEDLE TIME

As outlined above, in the majority of individuals the cause of a heart attack is a clot (thrombosis) in one of the coronary arteries. This clot can be dissolved by special drugs (thrombolytic agents). For this thrombolytic treatment to be most effective, it should be given within three hours from the onset of the symptoms of a heart attack, that is, three hours from the onset of chest pain, which is the most common symptom. Beyond six hours, the chance of success with this treatment is remote, because the heart muscle cells become irreversibly damaged and die between four and six hours after the blood supply has been cut off. Many patients are given treatment from 6 to 12 h after the onset of their symptoms with the hope of saving a few lives. The number of lives saved by treating 1000 patients with thrombolytic therapy given at less than 1, 3, 6, and 12 h from the onset of symptoms are 65, 27, 25, and 8, respectively. Widespread advice to the population at risk is crucial. Less than 33% of heart attack victims presently

receive therapy within four hours of the onset of symptoms.

It is important for all individuals age 35 and over to learn the symptoms and signs of a heart attack (see Section IV). Someone experiencing a heart attack should take two or three chewable aspirins [total dose 160 to 325 mg] and go immediately to the nearest emergency room of a hospital. All hospitals have the facilities to give drugs that dissolve clots in the coronary arteries. This life-saving treatment should be given within minutes of your arrival. If you need to wait more than 20 minutes to receive the drug, your spouse or person accompanying you to the hospital should complain. The choice of thrombolytic agent is not as important as the rapidity of administration. The real problem in the emergency room is the door-to-needle time. It is in excess of 30 minutes in more than 60% of patients admitted in the United States and in many countries worldwide. Fortunately in some countries facilities for immediate angioplasty and stent deployment are available to maintain patency of the infarct-related coronary artery.

IV. SYMPTOMS

The symptoms of a heart attack are often typical and easy to recognize. In some patients, however, symptoms can be so varied that both the patient and the doctor can be misled.

A. Type of Pain

People have unique feelings and sensations and use different words to describe similar symptoms. Heart attacks vary a great deal in their severity, and patients are not all alike. Thus, the characteristics of pain and the accompanying symptoms can be very different from one individual to another.

People experiencing a heart attack often have difficulty describing the type of pain or peculiar discomfort or distress. Some words used by various patients to describe the discomfort are in the following list.

- *Crushing or compressing pain or a heaviness over the chest:* The pain is most often described as “a crushing pain across my chest,” or the patient states that it feels like a very heavy weight or bar is resting on the center of the chest, especially over the breastbone (sternum). Another complaint is “it feels as if someone is crushing or walking on my chest.”
- *Viselike tightness, squeezing, constricting:* It feels as if the chest is in a vise or as if a tight metal band is being

pulled around the chest. The constricting feeling is often described as a tightness. The patient tries to describe the tightness by clenching a fist.

- *A disagreeable choking, strangling, sickening feeling in the center and across the chest:* This type of sensation can occur in patients with anxiety and may not be due to a heart attack. The strangling sensation is, however, very important because it resembles the discomfort in patients with angina pectoris. Patients with angina can develop chest discomfort mainly on exertion due to a lack of blood supply to the heart muscle. If the strangling sensation comes on at rest and lasts for more than 30 minutes, and especially if it is accompanied by the associated symptoms of a heart attack, seek attention.
- *Burning-like indigestion:* A burning discomfort or pain in the center of the chest, especially when accompanied by sweating or sensations listed above, must be taken seriously as it can be caused by a heart attack. Pain originating from the stomach is often burning in quality, but the associated symptoms differentiate heart from stomach pain. For example, heart pain is very often associated with profuse sweating, whereas stomach pain rarely ever causes sweating. There is a tearing, gripping pain as if the chest were being pulled apart from the breastbone.
- *Fullness in the chest:* As if it wanted to explode, may be a symptom of a heart attack, but it can be due to pain originating from the stomach or gullet (esophagus), for example, gas pains or reflux esophagitis.
- *Just a discomfort:* The patient may not perceive the sensation as pain but as a mild-to-moderate discomfort. Such a discomfort is a common feature and must not be ignored, especially if associated signs and symptoms are present. *Tingling, numbness, or heaviness* over the left or right arm may occur at the same time as the pain in the chest but is rarely the only manifestation of a heart attack. However, there are many causes of such symptoms in the arms, especially pain from the nerves supplying the arms, muscular pain, or a small stroke, in which case the hand and the arm will be very weak. A heart attack does not cause the arm or hand to become severely weak and it never causes paralysis. *A pointed, sharp, stabbing, sticking, knifelike pain* is seldom a manifestation of a heart attack. Such chest pain is often produced by other sources such as the chest wall or the lungs as in pleurisy and gas pains.
- *Dizziness and/or severe weakness:* This commonly occurs along with the chest pain of a heart attack, but is rarely the only symptom.
- *Nausea without vomiting or diarrhea:* If associated with pain in the chest or discomfort or shortness of breath,

weakness or dizziness, it can be a symptom of a heart attack. This rarely occurs without chest pain. In such a situation, associated shortness of breath points to a disturbance of the heart rather than the stomach.

- *Aching pain under the breastbone or arm:* This is occasionally described by patients.

B. The Location of the Pain

In the majority of individuals the pain of a heart attack is in the center of the chest under the breastbone (retrosternal). The pain is more often located under the lower two-thirds of the breastbone (see Fig. 3). Note that the heart projects to the left side of the breastbone and pain under or outside of the nipple line rarely comes from a heart attack.

The next most common area for pain is the upper half of the breastbone and the pit of the stomach. Heart pain occurs mainly in the center of the chest, and doctors often use the term “central retrosternal chest pain” as being typical of a heart attack. Finally, pain from all three areas can move (radiate) up or down to involve the entire chest, neck, throat, and lower jaw (not higher than the upper jaw) and commonly extends to the arms, forearms, and hands. Both arms may feel painful, heavy, numb, or tingly. Left arm discomfort is more common than right, and as shown in Figs. 1 and 2, the inner aspect (ulnar side of the arm) is the most common site of arm pain. Most of the arm or a small part such as the wrist may be the site of pain or discomfort without involvement of the chest. However, arm, jaw, or throat pain is usually accompanied by pain in the chest. If pain is present only in the upper limb, the accompanying symptoms and signs of a heart attack then become very important in making the diagnosis. For example, if there is associated shortness of breath, nausea, and sudden generalized weakness, the arm pain can be a manifestation of a heart attack.

Pain below the level of the belly button (umbilicus) is not from the heart. In addition, the pain of a heart attack very rarely goes through to the back. If it does, it is usually the zone between the left shoulder blade and the spine. Pain only in the area on both sides of a vertical line drawn through the nipple is most unlikely to be due to a heart attack (see Fig. 1). Centrally located breastbone pain can radiate across the entire chest, that is, to the left and occasionally to the right of the nipple line and upward to the neck and jaw. Thus, while in some cases, the size of the area may be that of one to three clenched fists or the entire span of the palm and outstretched fingers, pain can involve the entire front of the chest. Presyncope or syncope may

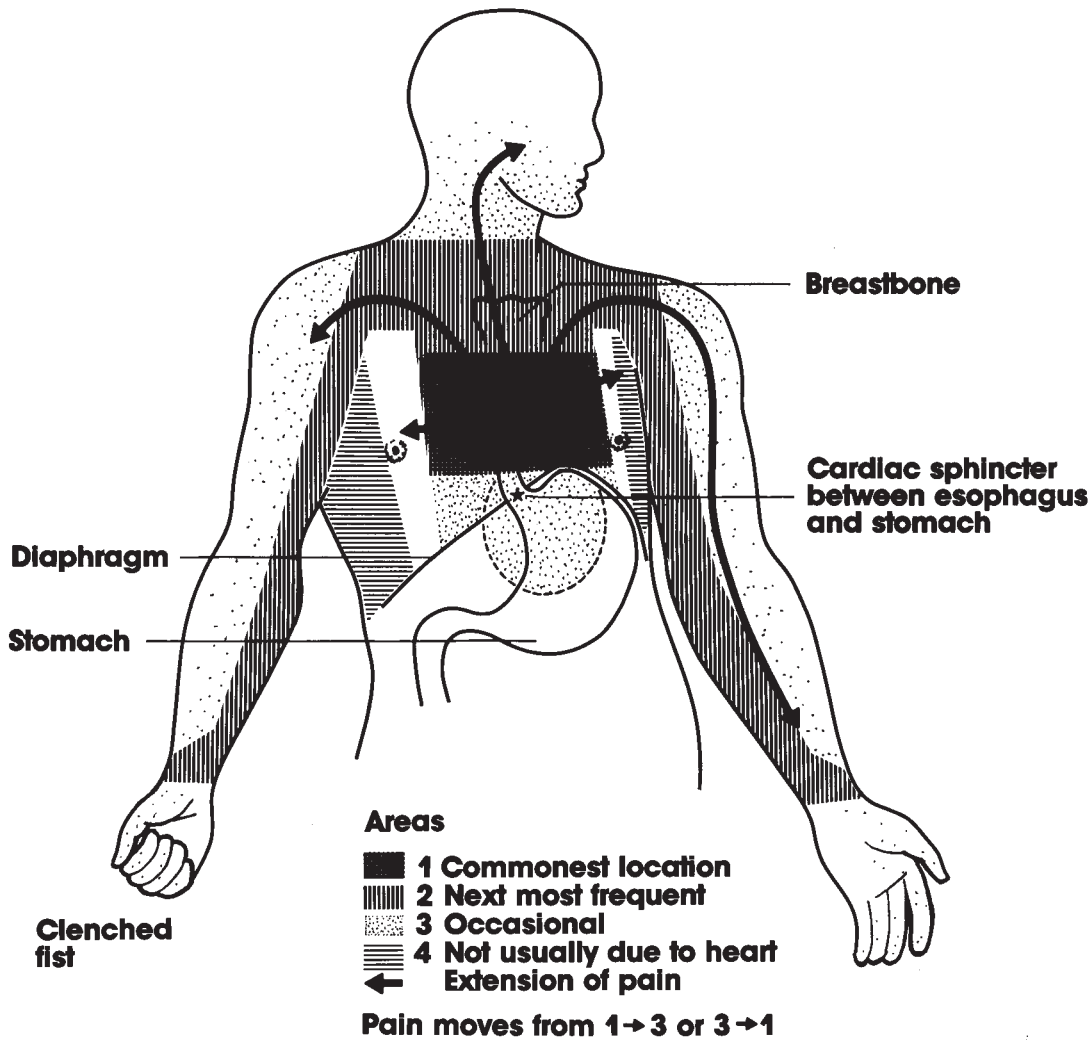

FIGURE 3 Common locations of heart pain.

occur due to bradyarrhythmias that occur mainly in patients with inferior myocardial infarction.

C. Severity and Duration of the Pain

The pain of a heart attack varies in intensity. In about 50% of patients it is described as severe pain. In about 10% of patients it is very severe and unbearable. In about 20% of patients, the pain is a moderate pain that is not in itself distressing and may well be a mild discomfort not reaching the level of pain. In such patients the associated symptoms are important, especially the feeling of anguish or fear of impending doom, which is common in patients who are having a heart attack. In about 10% of cases, pain is not prominent but one or more of the following accompanies

the vague discomfort: profound weakness, sweating, dizziness, nausea, or palpitations. In the remaining 10% of cases, particularly in diabetics and in the elderly, no symptoms occur and a heart attack is discovered only on subsequent routine electrocardiographic or autopsy examinations.

The pain of heart attack usually lasts more than 30 minutes and frequently one to four hours. A pain that lasts less than one minute and returns each time only to last a couple of minutes is usually not due to a heart attack, especially if there are no other associated symptoms. Pain lasting less than 10 seconds, even when recurrent, is not due to a heart attack. The pain of angina usually lasts from 1–5 minutes and its maximum is 15 minutes. If the pain is similar to the accustomed anginal pain but now lasts more than 20 minutes, especially if you are at rest, you must

seriously consider the possibility of a heart attack and have the situation assessed in a hospital emergency room. Diabetics and people over age 75 may have little or no pain during a heart attack. The elderly may get weakness or shortness of breath without chest pain.

The pain of a heart attack can come on gradually over 30 minutes to 1 h with increasing intensity that may remain steady for a few hours. It is usually a steady pain, not an on-and-off pain such as occurs with crampy stomach problems or abdominal pain that is usually described as colic (colicky or spasmodic pain). After one to four hours, the pain of a heart attack may suddenly disappear never to return and the individual may feel fairly well. The patient may no longer be disturbed and can make the mistake of not going to an emergency room or of leaving the hospital. Pain ceases as the heart muscle cells die when they are deprived of blood and dead muscle cells produce no pain. On rare occasions, pain may persist for 6–12 h in three or four bouts each lasting a few hours, and between times a dull pressure, tightness, heaviness or ache remains somewhere in the center of the chest or areas described above.

D. Warning Attacks

About 20–30% of patients who have a heart attack experience a “warning” some time during the two weeks prior to the attack. Patients who have chest pain (angina) suddenly notice a change in the duration and frequency of the pain. Instead of lasting 1–5 minutes, the pain may last 5–20 minutes and is brought on with less activity and may even occur at rest. This usually indicates that the angina is progressing or unstable. If the pain lasts longer than 30 minutes and is not relieved by two nitroglycerin tablets, it is likely due to a heart attack. If the pain lasts from 15 to 30 minutes, it is likely due to unstable angina that can lead to a heart attack over the next few months. In such a situation, a heart attack is preventable if the proper attention is sought. In patients who are not known to have angina, pain may suddenly come on for the first time during a bout of unaccustomed exertion such as shoveling snow, pushing a car, hauling a boat, or running. Chest pain or discomfort may last only 2–10 minutes and may be ignored only to return in full force within a few days. If pain occurs for only a few minutes, take special note if the pain is relieved within one to two minutes after stopping the precipitating activity. About 25% of such patients are likely to have a heart attack within the next month, which may be prevented by the combination of a beta-blocking drug and one aspirin daily. In addition, the ECG is usually normal in such patients when pain is absent.

Thus, they are often sent away from the emergency room. This must not deter patients from seeking appropriate expert medical care.

E. Associated Symptoms

As discussed above, pain or discomfort of a heart attack is nearly always accompanied by one or more symptoms that may help the patient or the doctor clarify the diagnosis. Therefore, identifying these associated symptoms is of vital importance.

1. Sweating is often profuse for at least a few minutes, in particular, the forehead is usually covered with a cold sweat. Indigestion or stomach pains that can be confused with a heart attack do not usually cause profuse sweating. It is well known that sweating occurs during a fever as the temperature rises above 100°F (38°C). A heart attack, however, does not cause a rise in body temperature until about the second day. Therefore, if you have sudden pain and definite fever, it is unlikely to be due to a heart attack.
2. Difficulty breathing is very common and may last for a few minutes. Persistence of shortness of breath for more than 10 minutes suggests that blood and fluid are accumulating in the lungs due to heart failure and requires prompt attention. Shortness of breath must be distinguished from sighing respirations, which involve taking one or two deep breaths and completely exhaling. Sighing is a common occurrence in individuals who are under stress and can be due to tiredness, exhaustion, or anxiety. Difficulty breathing means a patient cannot take a deep breath because the chest hurts; for example, if a rib is fractured or there is an infection on the outer surface of the lung membrane (pleurisy). Moving the chest wall produces lung pain; therefore, a deep breath cannot be taken because it causes pain and the individual is forced to take shallow breaths. Shortness of breath is a different sensation, and it means that you feel out of breath and are forced to gasp and struggle for breath and breathe rapidly and shallowly. The feeling is similar to that of running up four or five flights of stairs; afterward, you are out of breath and have to breathe harder and quicker. During heart failure the lungs have extra water and blood and become “stiff,” making a very deep breath impossible; therefore, breathing tends to be a little shallow. When shortness of breath is due to heart trouble, it is made worse by lying flat and can improve a little if the individual sits up and dangles the legs. Some nervous and anxious individuals hyperventilate, and this must be differentiated from true shortness of breath. The

- pain of a heart attack is not increased by taking a very deep breath, coughing, or sneezing.
3. A feeling of impending doom is experienced by virtually all patients who are having a heart attack. This fear and anxiety can provoke the secretion of epinephrine (adrenaline) and noradrenaline, which increases heart damage and may disturb the heart rhythm. The increase in adrenaline causes irritability of the dying heart muscle and triggers the production of extra beats. This may occasionally result in ventricular fibrillation during which the heart muscle does not contract but quivers. It is imperative that pain, fear, and anxiety be quickly relieved with adequate pain-relieving drugs such as morphine, oxygen, and with reassurance by a doctor. A patient will be reassured by quickly reaching a hospital where adequate facilities exist to relieve pain and combat the heart attack.
 4. Severe and sudden weakness may be associated with chest discomfort in about one-third of patients with a heart attack. The heart muscle is damaged and cannot pump with maximum force. Less blood is ejected from the heart at each beat; therefore, blood pressure falls and less blood reaches the brain. Thus the patient may feel weak and feel like fainting. Transient loss of consciousness for a couple of minutes can occur but is uncommon. The blood pressure soon becomes restored to near normal because of the body's compensatory responses, and weakness improves. In a few patients with a severe heart attack, the blood pressure remains very low and the weakness is profound (cardiogenic shock).
 5. Dizziness or light-headedness may occur in some patients due to a drop in blood pressure. Ringing in the ears (tinnitus) or severe rotational dizziness (vertigo) are not usually features of a heart attack.
 6. Nausea and occasionally vomiting accompany the pain in a significant number of patients. Severe pain from any cause may precipitate vomiting, and pain relievers such as morphine usually increase nausea and vomiting. However, unaccustomed sudden nausea may occur instead of pain or chest discomfort. Thus, distressing nausea with sweating and shortness of breath should be considered due to a heart disturbance until proven otherwise.
 7. Restlessness may occur as the patient tries to find a comfortable position. However, the pain or discomfort of a heart attack is not relieved by any particular position. The pain is not made better or worse by sitting, standing, lying, or rolling from side to side.
 8. Shortness of breath may develop if the heart muscle is very weak and heart failure occurs during the heart attack. The individual may even be gasping. In such cases, some relief is obtained when the patient is propped up in bed.
 9. A cough may suddenly develop with the production of frothy pink or blood-stained sputum.
 10. A sharp drop in blood pressure may occur signaled by confusion and loss of consciousness. If the heart attack is very severe this develops because of the lack of oxygen to the brain. Loss of consciousness is rare and a loss for more than two minutes is not a feature of heart attacks. When the heart muscle is suddenly weakened by a heart attack, the blood pressure may fall 10–40 mmHg and the pulse may become rapid. Thus in about half of patients with heart attacks, the systolic blood pressure may fall from an average of 125 mmHg to less than 105 mmHg. However, during the next few hours, if the heart attack is not a very large one, the body's compensatory responses may be sufficient to increase the blood pressure to the normal systolic range for the individual. The fall in blood pressure caused by a heart attack often reduces the blood pressure of a hypertensive patient to normal so that medications for high blood pressure may not be required for several months and in some cases ever. Patients with known coronary heart disease and perhaps all males over 40 and females over 50 would be wise to invest in a blood pressure instrument (sphygmomanometer). A blood pressure reading should be taken every six months so that the average blood pressure is known (see the chapter Hypertension). Thus, if chest discomfort or indigestion that is not relieved by an antacid and your systolic blood pressure falls more than 30 mmHg below the average baseline, visit an emergency room. If there is doubt because the discomfort seems to be in the stomach, an associated fall in blood pressure may warn you and save your life. On the other hand, because not all patients have a fall in blood pressure and the rare patient may have a mild increase in blood pressure because of pain and nervous reflexes, do not wait for a fall in blood pressure if chest pain with other associated symptoms is present; go directly to the emergency room.
 11. A change in heart rate accompanied by chest discomfort may indicate that a heart attack is under way. It is important for everyone over the age of 35 to learn how to determine the heart rate by feeling the pulse at the wrist. Chest discomfort is experienced and the pulse decreases by 20 or increases by 20 when at rest, this is likely to be a warning of a heart attack. For example, if the resting pulse rate is usually in the range of 70–80 beats per minute and it is suddenly at 50–60 beats per minute while having chest discomfort, the

disturbance likely originates from the heart. This is especially true if beta-blockers, which slow the pulse rate, are not part of a patient's drug therapy. A reduction in heart rate of 10 or less is too small to be diagnostic.

If the back of the heart muscle is affected during the attack (inferior heart attack), the pulse usually slows. If the front part of the heart muscle is affected (anterior heart attack), the pulse usually increases by 20–40 beats per minute and can reach 100–120 beats per minute at rest.

If you have coronary heart disease or if you are over 45, your home should be equipped with a sphygmomanometer, nitroglycerin, and plain aspirin. These are as essential as having a smoke detector or a fire extinguisher in the home. It is far more important to learn the symptoms and signs of a heart attack and the procedure for measuring your blood pressure and taking your pulse than it is to learn about cardiopulmonary resuscitation (CPR).

F. Clinical Example

A 48-year-old male had several typical symptoms during his heart attack. He suddenly experienced a disagreeable sensation in the chest, which increased to a heavy crushing sensation over and beneath the lower part of the breastbone. During the next 10–15 minutes, the pain felt like a heavy bar across the chest and within a few minutes spread to his left arm, which felt as heavy as lead. He was not known to have angina and therefore had no nitroglycerin available. He was overcome by a strange fear with a feeling that life was going to be extinguished. At this point, his pain had lasted about 40 minutes and was moderately severe but could not be described as unbearable. He was sweating profusely and upon further questioning, he admitted that it was his fear that prompted him to call the ambulance. It is true that many people are afraid of a heart attack and may develop anxiety. Many individuals with pain in different parts of the body may become a little anxious, but few feel as if they are strangling, and this sensation seems to produce great fear and anxiety.

V. PHYSICAL SIGNS

During the examination of a patient the following physical signs and abnormalities may be observed:

- The patient may appear anxious, apprehensive, and sweaty, and clammy.
- The location of chest pain may be indicated with a clenched fist held over the area of the chest wall.
- In patients with infarction of the inferior wall the heart rate is bradycardic at less than 60 beats per minute. This is found in more than 66% of patients. The blood pressure may have fallen 20–40 mmHg lower than the normal baseline for the given individual. In some individuals it may be 110 mmHg systolic or as low as 80 mmHg from cardiogenic shock. Some patients with anterior myocardial infarction may reveal tachycardia with a rate greater than 110 beats per minute and an increase in blood pressure. If the area of infarction is extensive the pressure usually falls, and in some patients cardiogenic shock or heart failure supervenes.
- In more than 25% of patients admitted to the hospital shortness of breath is caused by heart failure and physical abnormalities that include an increase in jugular venous pressure and crepitations and rales are heard with the stethoscope over the lower lung fields.
- Extra heart sounds such as a third or fourth heart sound maybe present.
- A soft mitral murmur of acute mitral regurgitation may suddenly occur caused by dysfunction papillary muscles.
- Often there are no abnormal physical signs observed. The finding of symptoms suggestive of a heart attack should not decrease the level of suspicion that the patient may have an acute infarction.

VI. MIMICS OF A HEART ATTACK

Several conditions cause symptoms that can mimic heart attacks. These are the most common:

- Indigestion and reflux esophagitis, hiatus hernia and esophageal spasm, acute gastritis
- Gallbladder disorders
- Lung infections such as pleurisy and pneumonia
- Pericarditis
- Chest wall pain originating from the muscles, ribs, intercostal nerves or costochondral joints, or due to costochondritis
- Arm pain and tingling and numbness in the left or right upper limb, not related to exertion such as a brisk walk

Rest assured that about half of all patients admitted to the hospital because of chest pain are not having a heart attack. These patients usually have an unstable form of angina pectoris, chest wall pain, stomach problems (in particular, reflux esophagitis with esophageal spasm), gallstones, and very rarely pericarditis. Occasionally no cause can be found.

A. Indigestion and Stomach Problems

Indigestion can be distinguished from the symptoms or discomfort caused by a heart attack. Pain of a heart attack can be present in the pit of the stomach (upper epigastrium) and the lower sternal area and may even be burning in type. Burning pain is more common with stomach and esophageal pain and is relieved by antacids, but the burning caused by a heart attack is not relieved by antacids. Associated profuse sweating or shortness of breath points to a heart attack rather than stomach or esophageal pain. Pain from ulcers in the stomach does not cause sweating, but it is related to meals and is often relieved by antacids.

B. Reflux Esophagitis and Hiatus Hernia

The cardiac sphincter is a muscle present at the junction of the esophagus and stomach (see Fig. 1). This sphincter closes tightly when an individual is at rest, but relaxes and opens in response to swallowing to allow food to enter the stomach. When you are not swallowing, the lower esophageal sphincter is tightly closed and prevents stomach contents such as hydrochloric acid and constituents of the bile from flowing backward into the lower esophagus (gastroesophageal reflux). In some individuals, either in response to a hernia of the stomach that protrudes into the chest along the lower esophagus (hiatus hernia), heredity, or aging, the sphincter becomes incompetent and opens during rest. It opens further if intra-abdominal pressure is increased during straining, stooping, or lifting heavy objects or during pregnancy. Reflux is always worse within one hour of eating, especially if excess fluids were taken. A high-fat meal delays emptying of the stomach, and reflux may last for hours rather than minutes. The reflux of acid and stomach contents such as pepsin, bile salts, and pancreatic enzymes causes severe irritation and at times inflammation of the lower esophagus. This condition is called esophagitis, which is similar to having an ulcer in the stomach. Distressing symptoms persist for many years and may result in narrowing (stricture) of the lower esophagus which results in difficulty in swallowing.

Reflux esophagitis often causes discomfort in the lower chest (retrosternal) as does heart attack or angina. The burning, pressure-like pain or discomfort can radiate along the entire breastbone to the back and sometimes the arm. Heartburn is common and regurgitation of bitter sour fluid or food, without vomiting, commonly occurs. Free acid reflux in the esophagus when an individual is sleeping can cause that person to be awakened by the discomfort. Spicy and acid foods, especially citrus juice, coffee, and

fatty meals increase the discomfort, which at times may be difficult to differentiate from a heart condition such as angina. As mentioned earlier, a heart attack can cause profuse sweating and shortness of breath, whereas reflux esophagitis does not. The ECG remains normal when pain originates from the esophagus or stomach.

The diagnosis of esophagitis is made by x-ray. Using a barium swallow or a meal, the radiologist documents the reflux of barium from the stomach into the esophagus. Tests are available to detect incompetence of the cardiac sphincter, and gastroscopy shows inflammation of the lower end of the esophagus with or without the presence of a hiatal hernia. A hernia often increases reflux, but the effect is variable. Reflux usually occurs without the presence of hernia and may not occur when a hernia is present.

Esophageal reflux is relieved by:

- Taking antacids
- Elevating the head of the bed and refraining from lying down for at least two hours after a meal or a drink of liquid
- Avoiding spicy foods, fatty foods, and acid liquids such as citrus juices
- Avoiding bending, stooping, and lifting, especially within one hour after meals
- Reducing weight
- Using drugs such as metoclopramide, which increases the tone or competence of the lower esophageal sphincter (see Fig. 1) and inhibitors of hydrogen secretion such as omeprazole

C. Esophageal Spasm

This condition is not as common as gastroesophageal reflux, but can closely mimic a heart attack and frequently occurs in patients who have esophageal reflux. Esophageal spasm can occur at any age but is more common after age 40. The most common site of pain is behind the lower half of the breastbone which can radiate upward along the breastbone to the throat, jaw, back, or arms. Pain can be squeezing, dull, or sharp; moderate to severe; and last minutes to hours. The pain can occur at night with the individual awakened by moderately severe pain that can be mistaken for a heart attack. Pain may come on during or after a meal, especially after a drink of cold liquid. Severe anxiety and stress can produce an attack, but there may be no precipitating factors.

In many patients with esophageal spasm, there is some difficulty in swallowing, and this can occur with or without the presence of pain. The diagnosis is usually

confirmed by x-ray fluoroscopy during which the individual swallows liquid barium. Other confirmatory tests can be done by a gastroenterologist. Nitroglycerin may relieve the pain of esophageal spasm, and a calcium antagonist, nifedipine, which relieves muscle spasm, can sometimes abolish the pain. Antacids or warm milk may relieve the pain of esophageal spasm, but not the pain of heart attack. An ECG done when pain is present during esophageal spasm is normal and excludes a heart attack.

D. Lung Infections

Pneumonia may produce pain, and this is usually a sharp pain that is made worse by taking a very deep breath or coughing. The pain occurs because the outer membrane of the lung, the pleura, is involved in the inflammation. Usually there are fever, chills, and cough.

E. Pericarditis

This is an inflammation of the outer membrane of the heart, which can be caused by a virus or bacteria or may occur a few days after a heart attack. The pain is usually sharp, located over the lower breastbone or a little to the left of the breastbone, and is sometimes made worse by deep breathing when the pericardium and pleura are both involved. The pain is usually made worse by lying down and improves within seconds or minutes on sitting up and leaning forward. Three or four days after a heart attack a few patients may develop pericarditis. This resolves in a few days. There are many other causes of pericarditis such as kidney failure, cancer, lupus, radiation, and as a side effect of some drugs.

F. Chest Wall Pain

Pain occurring in the wall of the chest is extremely common and may be due to pain in the muscles, ribs, and costochondral joints. A costochondral joint is formed at a point where the hard bone of the rib joins the softer bone (cartilage) that attaches to the breastbone. The costochondral joints frequently get irritated producing costochondritis. Pain can be localized to a small area the size of one or two fingertips and the area is tender to pressure. Sitting in a draft or exercise such as raking a lawn may aggravate the condition. Costochondritis is very common between the ages of 30 and 60, and occasionally patients may become worried that it is the heart. This condition is more common in women and occurs more often on the left side over the second and third costochondral joints. The pain is

usually relieved by pain medications such as aspirin, but can recur over several months. The doctor may inject the joint with a combination of a local anesthetic and a cortisone compound. This causes relief for several months during which time nature heals the condition, but the pain may recur. This is a benign condition that never gets worse and does not lead to heart attacks or arthritis in other parts of the body. However, in a few patients costochondritis coincided with heart pain.

G. Arm Pain, Tingling, and Numbness

Many people experience tingling and numbness in the arm if the arm is rested over the back of a chair for several minutes or hours or by sleeping on the arm in an unusual position. This pain is caused by pressure on the nerve and normally subsides quickly once the unusual pressure has been removed. Arm pain, tingling, and numbness may occur when the nerves supplying the upper limb become affected by conditions such as arthritis of the spine in the neck region. Pressure is then exerted on the roots of the nerves as they emerge from the spine. Cervical disk disease is similar to sciatica, which produces low back and leg pain. Pain arising from sciatica usually lasts several hours and may occur over many days and may be related to posture. It is an aching pain that is only occasionally associated with chest pain. Nerve and muscle pain does not get worse during vigorous walking. This serves to differentiate the pain from angina, which can cause pain in the arm during brisk walking. Moderate to severe pain in the wrist or the arm without trauma or other precipitating cause, especially if there is no tenderness on pressure or movement of the limb, warrants medical advice.

VII. AMBULANCE TRANSPORT

A. What to do Before the Ambulance Arrives

If you think you are experiencing the symptoms and signs of a heart attack (see Section IV) you should get to the hospital emergency room as quickly as possible. Denial or wishful thinking that the pain will disappear in the next hour is about the worst thing you can do. Do not try to reach a physician for advice. Call the ambulance first, then ask someone to make a call to your doctor or cardiologist. If you cannot reach the doctor, leave a message; do not wait for a reply. If you are fortunate to live in an area where a mobile heart ambulance exists, then please use this service. If this is not available, use 911 or ambulance service. If no ambulances are available, have someone drive

you immediately to an emergency room. Do not drive yourself to the hospital if you have pain lasting longer than 15 minutes, particularly if you have unusual profuse sweating, shortness of breath, dizziness, or feel weak.

While waiting for the ambulance, which should arrive within minutes of your call, try to keep calm. Fear and panic cause further damage to the heart because they provoke the secretion of adrenaline, which increases the work of the heart and may increase the size of the heart attack or induce abnormal heart rhythms. While waiting, do the following:

- Chew and swallow one 325-mg plain aspirin immediately or preferably take two or 3 soft, chewable 80-mg aspirins. The chewable baby aspirins are more effective than coated aspirin or a hard regular aspirin in preventing a heart attack because they are quickly absorbed in the stomach. Chewable baby aspirin should be carried by all patients who have had a heart attack or those at risk. The use of two chewable aspirins is more important than use of nitroglycerin under the tongue. Nitroglycerin does not prevent a heart attack or death, but chewable aspirins have proved effective in randomized clinical trials to prevent fatal or nonfatal heart attacks.
- Do not take a coated aspirin because it takes several hours to be effective. Any form of regular aspirin may suffice to prevent a heart attack, but coated aspirins are not recommended for emergency prevention of heart attacks because they take too long to dissolve and to be absorbed by the stomach.
- Sit or lie propped up on three or four pillows and take a nitroglycerin tablet under the tongue. One tablet can do no harm. It will help calm your nerves as it will increase the blood supply to the coronary arteries. It also pools blood in the veins of the legs; therefore, less blood returns to the heart so there is less work for it to do. Nitroglycerin may decrease the size of a heart attack. It is reassuring to take one tablet under the tongue and believe that it will help. The drug is not as effective if you are lying flat. It is most effective if you sit up with your legs dangling over the edge of the bed or in a comfortable chair as this causes the blood to stay in the legs longer. Nitroglycerin may cause a headache, but this is to be expected because the drug dilates arteries including those in the scalp as well as the coronary arteries.

There is no need to worry about the throbbing that you will feel in the head. Nitroglycerin does not increase blood pressure. Put on a pajama top, loose shirt, or blouse. Do not overdress. There is no reason to put on a vest, sweater, shirt, tie, jacket, or blouse that is difficult to remove. These

garments will only have to be pulled off when you are in pain and lying on a stretcher in the emergency room. Therefore, if it is not excessively cold, wear clothing that can be easily opened to allow the doctor to examine you quickly and facilitate placement of the leads of the ECG that must go on the chest. In addition, blood pressure is best taken with no garment around the arm. Every ambulance should have blankets to keep you warm. It is a waste of precious time to try to remove clothing in the emergency room.

When the ambulance arrives, you will be given oxygen. Oxygen given at this stage will help allay anxiety and panic. Put the oxygen mask right over your nose and mouth and breathe in the gas. There is nothing like believing that something will help when you are scared to death. We strongly recommend the use of oxygen and nitroglycerin as a technique to break the fear-anxiety-adrenaline reaction.

The reassurance of a trusted physician or specialist and the use of morphine can be lifesaving. Until these are available, use aspirin, nitroglycerin, and oxygen. They will help. Someone telling you to stay calm during the pain and fear of a heart attack is of no avail. Therefore, do the things that carry some hope.

Remember that morphine is used not only to relieve pain but to relieve anxiety. Morphine is the best drug for this purpose, and you should not be opposed to its use. If a second injection is necessary, even if your pain is mild, do not object to its use.

B. Mobile Coronary Care Ambulance

When a plaque of atheroma ruptures, a clot is formed within minutes. This causes centrally located chest pain associated with sweating and often shortness of breath. If you believe you are having a heart attack, quickly go to the emergency room of the nearest hospital. Approximately 500,000 individuals with heart attacks die each year in the United States and Canada before reaching the hospital. The only way to save some of these lives is by the use of mobile heart squads. It is estimated that about 50,000 lives could be saved annually in North America by the use of mobile heart squads.

The first mobile coronary care ambulances were operated at the Royal Victoria Hospital in Belfast by Dr. J. F. Pantridge and Dr. J. S. Geddes in 1965. The objective was to reach the patient quickly and stabilize the heart rhythm, relieve pain as well as to afford reassurance, and thus prevent death from abnormal heart rhythms. When the heart is found to be quivering and not contracting (ventricular fibrillation), the heart is defibrillated using a portable defibrillator. The success of such

units led to the establishment of coronary care ambulances in Seattle and several other American cities.

Properly equipped emergency care ambulances are still lacking in Canada, in many areas of the United States, and in most countries worldwide. Perhaps with the advent of the new drugs that dissolve clots in the coronary arteries and the emphasis on early administration of such treatment, special mobile units may become necessary if we wish to save the countless lives lost before reaching hospitals.

In North America about half a million deaths occur outside the hospital whereas about 60,000 die from a heart attack in the hospital. It is estimated that coronary care units save about 30,000–40,000 lives annually in North America, but at a very high but justifiable cost of running such units. It is simple to equip and run mobile emergency care units. The vital equipment consists of a lightweight portable defibrillator, an ECG recorder, intravenous preparations, morphine, and oxygen. A system in a city of one million people can be serviced by two units at a cost of about \$100,000. It is the manpower that escalates the cost of running such units. It is feasible to send out a trained physician, a nurse, and a driver trained in CPR in such a unit. Perhaps doctors in training will see the need for such services in a community and help to organize systems with the help of their chiefs and with financial assistance from service clubs until government bodies are made aware of the lifesaving potential that justifies the cost of mobile emergency care units.

Over the next decade drugs to dissolve clots in the coronary artery will need to be given intravenously by trained staff running mobile heart squads. This should avoid a further 30- to 40-minute delay on reaching an emergency room. The public can assist by lobbying their elected representatives to achieve better mobile emergency care services and treatment in ambulances or in the home on the arrival by the ambulance staff.

VIII. WHAT TO EXPECT IN THE HOSPITAL

If you still have pain on arrival at the emergency room, you can be reassured that the pain will be relieved within five minutes. Usually no time is wasted. The emergency room staff are primed to move quickly to deal with ambulance cases, particularly those suspected to be heart attack victims. You are mainly expected to say to the nurse or the doctor that you are having chest pain. Point to the area of pain, indicating whether it is severe or very severe and that you are scared and would like something as soon as possible for the pain. You can then cooperate by answering

all the other questions that the doctor may wish to ask. You will usually have to state whether you are allergic to medications. You will quickly receive an intravenous injection of morphine, which relieves the pain in two to five minutes. Because the injection is given intravenously, very small doses are used; for example, it may be given in 2-mg increments every minute until the pain is completely relieved. Do not be embarrassed to say that you are scared. A heart attack makes everyone afraid, and the doctor may sometimes forget this. Also, relief of pain by morphine can prevent some complications of a heart attack.

You will be quickly hooked up to continuous oxygen, and a blood pressure cuff will be placed around your arm. The doctor will examine you and ask you relevant questions. There is very little reason for the doctor to ask more than 12 questions, because the diagnosis is usually easily made from your description of the chest pain and from the ECG that is done within minutes of your arrival.

The ECG writes the electrical rhythm and rate of each heartbeat. You will be immediately hooked up to a cardiac monitor and small electrodes similar to ECG electrodes will be placed on your chest and connected to the monitor. The electrodes detect the electrical impulses from the heart, which are recorded continuously on a monitored screen. The nurses and doctors can see the visual display of the continuous ECG, showing each heartbeat as well as the important heart rate and rhythm of the heart. If the ECG confirms the diagnosis of heart attack, streptokinase, tenecteplase, t-PA, or reteplase is given intravenously to dissolve the clot. In some hospitals with equipment and special staff, a coronary angiogram is done and angioplasty is used instead of drugs to clear the obstruction in the artery. This technique is lifesaving but needs to be tested in large clinical trials.

The area of damaged muscle during a heart attack may cause electrical discharges that interrupt the normal clock-like rhythm of the heart, which causes premature beats. These premature beats will show up on the monitor (see the chapter Arrhythmias/Palpitations). If these extra beats are frequent or of a special variety, they act as warning signals and the doctor suppresses these beats by giving a drug called lidocaine intravenously and then through a continuous intravenous drip. Lidocaine is effective in stabilizing the heart rhythm and has no serious side effects, so you have no need to worry or be afraid.

It is important for you to start seeing the brighter side of things. Once the morphine is given, the worst is over. You are out of danger because you have made it to the hospital where expert care is available. Most deaths occur before the patient reaches the hospital. Those who die before reaching the hospital have either a very large heart attack, experience electrical disturbances that cause the heart to quiver

(ventricular fibrillation) or stop beating, or have remained too long outside of the hospital with extensive damage to the heart muscle.

Next, blood is taken and several blood tests are done. Cardiac enzymes are taken for diagnostic purposes. The heart muscle cells that are deprived of blood undergo a series of changes ranging from injury to death of the cells and liberate cardiac enzymes, which can be detected in the blood. The most reliable of these enzymes are troponin and creatine kinase (CK). The special fraction of CK (CK-MB) that is derived solely from heart muscle is measured to distinguish it from the release of ordinary skeletal muscle enzymes. The ECG is taken hourly for six hours then daily for a few days. This is still the quickest, most reliable, and least expensive test for detecting a heart attack.

The damaged heart muscle will heal itself over the next few weeks. Although it will be difficult, you should try not to worry about the future at this time. You need rest and reassurance. Let others do the worrying.

A. Coronary Care Units

Hospitals that provide efficient heart care strive to get patients to the coronary care unit (CCU) within a half hour of emergency room arrival and soon after commencing streptokinase or t-PA. The CCU is a special area of the hospital, which usually consists of 6–12 beds with a staff of specially trained doctors and nurses along with sophisticated electronic equipment to deal with heart attack patients. It will take some adjustment, over 6–24 h, for a patient to get used to all the gadgets. The patient will have already had an ECG in the emergency room, and this is repeated in the CCU and once daily for three days. The patient is attached to a cardiac monitor similar to the one used in the emergency room.

The ECG is the main diagnostic tool and can accurately make the diagnosis in the majority of patients. In more than 90% of cases during a first heart attack, typical findings occur on the ECG and are easily recognized. If the first ECG is only suggestive of a heart attack, repeat ECGs 6 and 24 h later usually give an accurate diagnosis. In patients who have had previous heart attack, the ECG is less diagnostic and is positive in about 75% of the cases. Less than 10% of patients having a first heart attack have an ECG that may be nondiagnostic, and it can be normal in about 5% of the cases. In these difficult cases, when the ECG is repeated 6–24 h later, typical changes confirm or exclude the diagnosis of a heart attack.

It is necessary in a difficult case for the doctor in the emergency room to pay special attention to the patient's

description of the chest discomfort. Therefore, in such cases, the patient must put up with answering questions posed by several doctors. Perhaps the fortunate patient is not having a heart attack. In this case, the doctor may elect to admit the individual for 24-h observation. The CK enzyme starts to increase about four to six hours after the heart attack and may be normal in some cases if taken very early during the attack. A careful physician often repeats the ECG and blood test for troponin or CK-MB every two hours. If both ECG and blood enzymes are normal and the description of chest pain does not suggest a heart attack, the doctor may elect to send the individual home after 24 h. The patient is advised to return to the emergency room if the pain recurs. A risk is therefore taken and the public must understand that the doctor may not be able to admit every patient and that the pain may be due to other causes. Policy varies depending on the physician in charge. If doubt exists, the patient is admitted, and if three ECGs done over a 48-h period and a repeat test for cardiac enzymes is normal, then a heart attack can be excluded with confidence. In rare instances, the diagnosis is firmly established only on the third day of the illness.

A routine chest x-ray is taken in the hospital. It cannot diagnose a heart attack, but it is useful in making the diagnosis of heart failure, which occurs for a few days in more than 50% of heart attack patients.

Occasionally the blood pressure is very low and drug combinations are given intravenously to maintain the systolic blood pressure between 90 and 100. Blood pressure of 95–105 systolic is very common in patients having heart attacks, but it can be 110–140 in those who had slightly higher blood pressure before the heart attack.

In some units, other instruments are used to monitor the amount of blood ejected from the left ventricle, that is, the cardiac output. Because of the many parameters that are measured, several veins in the arm may be used for the introduction of a venous tube, which is usually about one to two inches long and is not harmful.

An echocardiogram may be done to verify the strength of the heart muscle. Nuclear scans can be helpful in the few patients who do not have classical diagnostic findings on ECG or cardiac enzymes. It is not routine to have nuclear scans because the ECG and blood test for cardiac enzymes are sufficient in more than 90% of the cases for a firm diagnosis. Nuclear scans and other tests increase the cost to both patient and state and are not justifiable.

In patients with a heart attack and complications such as severe heart failure, a monitoring catheter may be inserted into the right side of the heart to monitor the pressure within the heart. This assists with evaluation of the treatment in critically ill patients. If the patient is not

critically ill and complications have not occurred, this expensive and invasive test is not justifiable.

The procedure for introducing the catheter is simple. The skin area over the vein is infiltrated with local anesthetic. The specially made fine tube (catheter) has a tiny balloon and sensing devices at its tip. The catheter is inserted into the vein and threaded into the right ventricle and the pulmonary artery. Its position is verified by x-ray.

Patients with severe heart failure and very low blood pressure may require several drugs and fluid replacement given intravenously. The monitoring catheter that is positioned in the pulmonary artery is useful for the infusion of intravenous preparations, but a simple intravenous line in the arm vein is preferable in the majority of cases, because this method is inexpensive and devoid of complications.

On day one treatment is continued with oxygen, which can be discontinued after a few hours in the majority of patients. The amount of oxygen in the arterial blood is tested by a simple measurement, and if this is normal, the oxygen is usually discontinued. Generally, no food or drink is allowed for the first eight hours, since the process of digestion steals blood from the heart; also, if vomiting occurs, vomitus may be aspirated into the lung. During the stay in the coronary care unit, the patient receives sufficient sedation to prevent anxiety and to ensure adequate rest.

In the CCU on day two a light diet is usually given and increased over a few days to a normal diet. On the second day, patients are usually sitting at the bedside. Late on the second or on the third day, the patient is moved from the CCU to an intermediate care area or to a ward with other patients. In the standard room, the patient is allowed more freedom each day starting with walks to the bathroom and progressing then by day five to walks in the corridor of the hospital. If the individual is making a good recovery, the intravenous tubes are removed by the third or fourth day. The education process will now begin and both husband and wife are usually given instructions together in a question-and-answer period each day. The individual is often concerned that pain is no longer present and wonders why it is necessary to stay in the hospital. The pain of a heart attack usually disappears between one and six hours, and in most patients, there is usually no recurrence of pain during the hospital stay, and in many there is no pain for several years.

By the fourth day, the patient is very well and enjoys meals and walks around alone. At this stage the doctor will wish to discuss the question of how much rest is necessary. The patient must understand that a blockage of a coronary artery has taken place. This caused damage and death to a segment of heart muscle cells. Special cells in the body that form bridges (scar tissue cells) move into the area and form

scar tissue joining the two normal areas of heart muscle. The scar tissue is similar to that following the healing of a surgical incision. It takes time for scar tissue to form and heal. The healing process usually takes three to six weeks. During the 1950s, it was common practice to keep patients in the hospital for four to eight weeks. In the 1970s, it became apparent that after seven days, if there were no complications, most patients could be allowed home. In some countries discharge on the fourth or fifth day is not unusual. In most hospitals, patients are discharged home between the 6th and 10th day depending on the size of infarction, complications, and their home situation.

By the fifth day the patient is walking approximately 100 feet, two or three times daily. By the 7th to 10th day, the patient has been supervised while walking up one flight of stairs and should have had a stroll on the treadmill to reach a heart rate of 120 beats per minute. This modified stress test is repeated in 6–10 weeks and decisions are then made regarding further medical treatment, angioplasty, or bypass surgery if the decision was not made prior to discharge. In many patients percutaneous intervention (PCI) involving angioplasty and intracoronary stent would have been done during day one.

Discharge from the hospital is usually on the fifth or sixth day, but in many hospitals worldwide discharge is on the third or fourth day, particularly if PCI was successful.

IX. DIAGNOSTIC TESTS

A. Electrocardiogram

Despite the advent of expensive and sophisticated cardiologic tests, the ECG remains the most reliable tool for the confirmation of acute myocardial infarction. The ECG — not the blood cardiac enzymes (CK-MB and troponin), echocardiogram, cardiac nuclear scans — dictates the rapid administration of lifesaving thrombolytic therapy or angioplasty with intracoronary stent.

Two major types of acute infarctions are recognized from the ECG tracing: ST segment elevation myocardial infarction (see Figs. 4 and 5) and non-ST segment elevation myocardial infarction (formerly called non-Q-wave myocardial infarction; see Fig. 6; also see the figures in the chapter entitled Electrocardiography). These diagnoses have replaced the old terminology, transmural and nontransmural myocardial infarction. Today a new term, acute coronary syndrome, has been used to identify patients with acute chest pain who may have ST segment elevation infarction or non-ST segment elevation infarction. Patients without biochemical markers, CK-MB, or

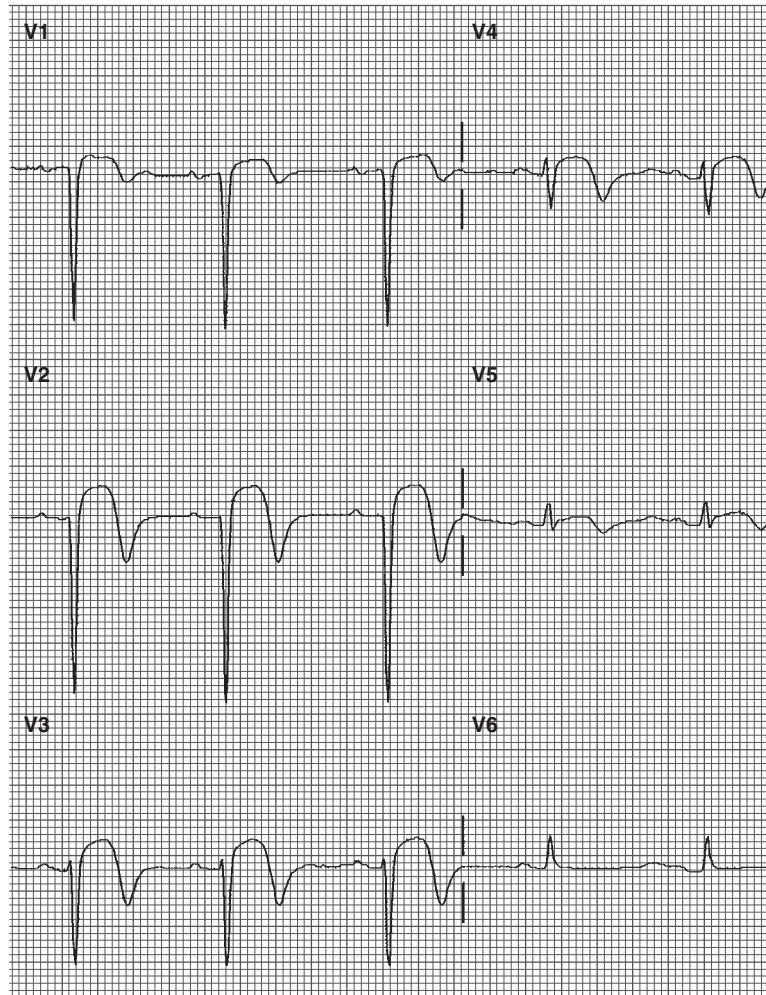

FIGURE 4 (A) ST segment elevation in V_1 through V_5 ; poor R wave progression in V_2 through V_4 typical of recent anterior infarction. (B) Variation in shapes of ST elevation. (From Khan, M. Gabriel (2003). *Rapid ECG Interpretation*, second edition. Philadelphia: W.B. Saunders.)

troponins are regarded as having unstable angina. Figure 5 illustrates the current system using acute coronary syndrome. This new terminology is somewhat redundant. It appears that physicians bask in the formulation of new syndromes sometimes with unneeded terminology. To retain the term ST elevation myocardial infarction (MI) would be simple. The diagnosis is easily made and therapy for this condition has been well-defined since the 1980s. It could also be simple in patients with acute chest pain to use the term non-ST elevation if there is ST segment depression with positive cardiac enzymes MI. Both terms became ingrained during the late eighties. Patients with negative troponins are labeled unstable angina. In Fig. 7 the words acute coronary syndrome are synonymous with “cardiac-like chest pain” and can be eliminated from the algorithm. Nonetheless, the term acute coronary syndrome is here to stay and is likely to be used in many countries.

There is no test to rival the ECG in the diagnosis of arrhythmias, which are a common clinical cardiologic problem and a common finding in patients with acute myocardial infarction. Arrhythmias occurring during the first few hours of infarction may be life-threatening.

B. Blood Tests/Cardiac Enzymes

The results of cardiac enzymes, CK-MB and troponins, are not relevant for the diagnosis of ST segment elevation MI. This diagnosis must be made within the hour by ECG and cannot await the results of cardiac enzymes that become elevated only after 6–12 h from the onset of chest pain. An elevation of troponin levels indicates the presence of micro-infarction, and if the ECG does not show ST

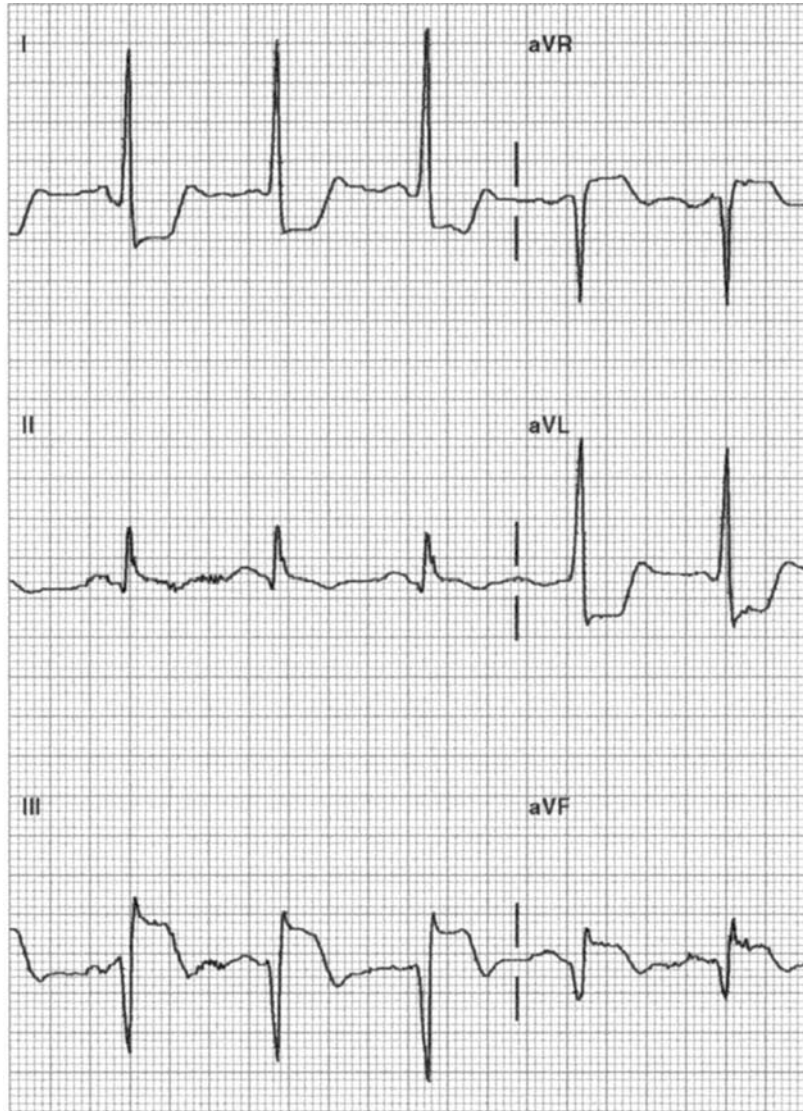

FIGURE 5 Deep pathologic Q waves in II, III, and aVF with marked ST segment elevation indicate acute inferior myocardial infarction. (From Khan, M. Gabriel (2003). *Rapid ECG Interpretation*, second edition. Philadelphia: W.B. Saunders.)

elevation, then the diagnosis is clearly non-ST segment elevation MI.

infarctions, heart failure, valvular abnormalities, and pericardial effusion.

C. Echocardiography

This test is not indicated in all patients admitted to the emergency room. The area of infarcted muscle is detected as an area that moves very poorly during systolic contraction and is described as the presence of left ventricular wall motion abnormalities. An ejection fraction can be obtained and is useful for risk stratification. Echocardiography is useful in patients with complicated

X. SPECIFIC MANAGEMENT

A. Pain

I. Morphine

Pain precipitates and aggravates autonomic disturbances which may cause arrhythmias, hypotension, or hypertension, thus increasing the size of infarction. Pain relief must be achieved immediately. Morphine is the drug of choice

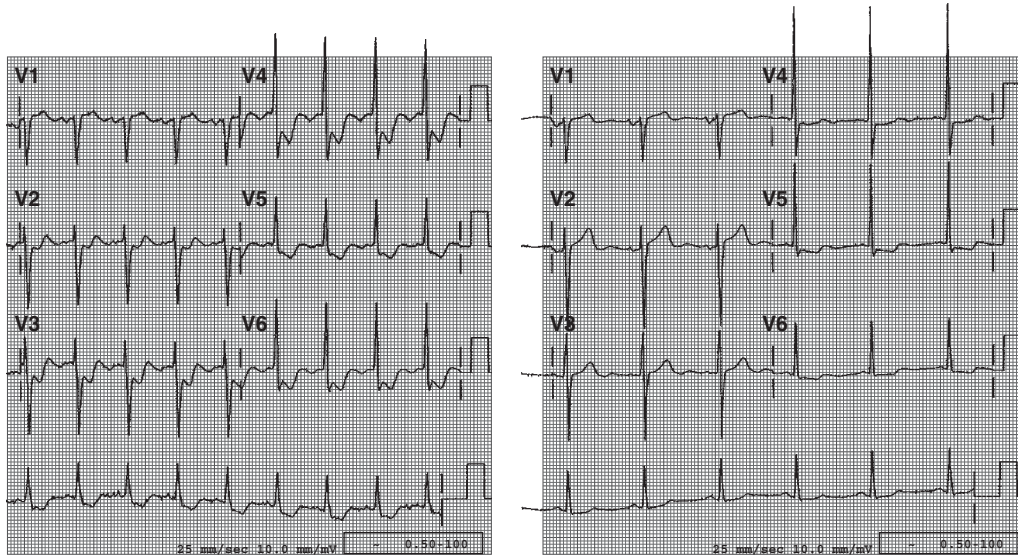

FIGURE 6 (A) Non-Q-wave infarction (acute subendocardial infarction) in a patient with a clinical picture of infarction and elevated CK-MB. Note widespread ST-T depression in the limb and chest leads but no associated Q waves. (B) The same patient's ECG tracing 18 hours earlier than depicted in (A). (From Khan, M. Gabriel (2001). *On Call Cardiology*. Philadelphia: W.B. Saunders, p. 105.)

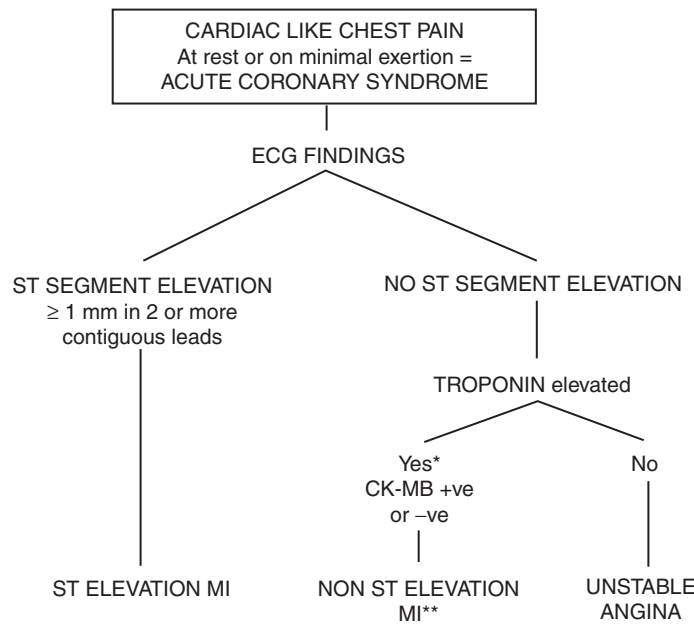

FIGURE 7 Diagnosis of ST segment elevation myocardial infarction (MI) and non-ST segment elevation MI. *Excludes false-positive. If troponins are unavailable, being positive for the MB isoenzyme of creatine kinase (CK-MB) also confirms the diagnosis. Patients who are CK-MB negative and have associated ECG changes are at high risk of unstable angina. **According to the American College of Cardiology/American Hospital Association guideline, ≥ 0.5 mm associated with ST depression; according to the European Society of Cardiology, ≥ 0.1 mV, 1 mm.

for relief and should be given slowly intravenously: 4–8 mg IV at a rate of 1 mg per minute repeated if necessary at a dose of 2–4 mg at intervals of 5–15 minutes until pain is relieved. Morphine allays anxiety, relieves pain, and causes venodilatation, therefore, reducing preload. This is of some benefit in patients with left ventricular failure.

2. Beta-Blockers

Beta-blockers must be given a more important place in the management of chest pain resulting from myocardial infarction. They can be considered as important second-line agents for the control of ischemic pain. This is

important in patients with acute infarction accompanied by sinus tachycardia and systolic blood pressure greater than 110 mmHg. Dramatic pain relief and reduction of ST segment elevation can be obtained by the administration of a beta-blocking agent and the requirement for opiates is thus reduced. In some patients pain has been documented to be relieved by the administration of beta-blockers without concomitant use of opiates. Metoprolol 5 mg at a rate of 1 mg per minute is repeated if necessary at 5-minute intervals to 10 mg. A maximum dose of 50 mg followed by an oral dose of 50 mg every 12 h can be given if no contraindication exists (asthma, heart block, bradycardia of less than 50 beats per minute, and blood pressure less than 90 mmHg diastolic).

3. Intravenous Nitroglycerin

Intravenous nitroglycerin is used if pain is not relieved by morphine and to assist the management of left ventricular failure if present.

4. Oxygen

Oxygen is given two to four liters per minute for the first two to four hours then discontinued. Oxygen is used further if left ventricular failure is present or if hypoxemia is observed on blood gas analysis.

B. Strategies to Reduce Morbidity and Mortality

Table 1 lists strategies that are important for the reduction of morbidity and mortality.

I. ACE Inhibitors

In patients with anterior infarction an ACE inhibitor is commenced provided the systolic blood pressure remains greater than 100–110 mmHg. These agents are used if heart failure is present or if the ejection fraction is less than

40% (see the chapter Angiotensin-Converting Enzyme Inhibitors/Angiotensin Receptor Blockers for their beneficial effects in heart failure and in patients with low ejection fractions).

2. Beta-Blockers

These agents have been shown in large randomized clinical trials to reduce morbidity and mortality in patients following myocardial infarction in the acute phase and to improve survival over the long term. The CAPRICORN study caused a significant 23% reduction in all-cause mortality in patients in whom the drug was commenced during infarction and continued for 2.5-year studies. The COPERNICUS study showed that beta-blockers also improve survival in patients with myocardial infarction and mild-to-moderate degrees of heart failure. (See the chapter Beta-Blockers for other clinical trials.)

3. Thrombolytic Therapy

Five drugs have been shown to be successful in dissolving clots in the coronary artery and released for general use: streptokinase, tissue-type plasminogen activator (t-PA), reteplase, anistreplase (APSAC), and tenecteplase (TNKase). Others thrombolytic drugs are investigational.

Streptokinase has been shown to be useful when infused directly through an arm vein, and it dissolves the clot in about 60% of patients. It must be given within four hours of the onset of symptoms to be successful, but some benefit is seen up to six hours. Streptokinase, t-PA, reteplase, or APSAC given intravenously through an arm vein has a 70% chance of dissolving a clot in the coronary artery. An Italian clinical trial in 1986 and a UK trial in 1988 showed intravenous streptokinase to be useful in preventing deaths in patients given the drug within four hours of onset of their heart attack. This beneficial effect is markedly

TABLE 1

Thrombolytic Therapy: Timing of Admission and Survival

Time from onset of symptoms	Lives saved per 1000 treated
Within 1 hr	65
2–3 hr	27
4–6 hr	25
7–12 hr	8

TABLE 2

Strategies to Reduce Morbidity and Mortality

Prompt defibrillation is performed where required.
Aspirin 320 mg, preferably 4 chewable 80 mg aspirin, chewed and swallowed rapidly achieves high blood levels; aspirin causes a decrease in mortality rate and enhances the efficacy of thrombolytic agents.
Prompt administration of thrombolytic therapy is performed if no contraindication exists. Therapy is commenced in a mobile emergency unit or within 15 min of arrival in an emergency room.
Pain is abolished by opiates.
A beta-blocking drug is administered if there is no contradiction.
ACE inhibitor therapy is given.

improved when an aspirin is taken along with streptokinase. The drug t-PA (alteplase) does not cause allergic reactions as seen occasionally with streptokinase. These reactions are, however, very mild and occur in less than 2% of patients. t-PA is slightly more effective than streptokinase, but the cost is \$2000 versus \$200. Although the benefits are mainly seen up to 6 h from onset of symptoms, the timing has been extended to up to 12 h after the onset of symptoms. Table 1 gives the timing of administration of thrombolytic agents and survival.

There is great hope for patients who have suffered a heart attack provided they can get to the emergency room of a hospital quickly and that thrombolytic therapy is given within 15 minutes of arrival or within 3 h of onset of symptoms.

a. Streptokinase, 1986

The Italian GISSI trial done in 1986 was the first large randomized clinical trial of thrombolytic agents. It indicated that streptokinase produces adequate reperfusion if it is given within the first three hours of onset of the ischemic event. The GISSI study and sis-2 indicated that an IV infusion of 1.5 million units of streptokinase over one hour is not particularly expensive or troublesome to give routinely and most important, heparin is not required.

b. Alteplase (t-PA), 1993

The Global Utilization of Streptokinase and Tissue Plasminogen Activator for Occluded Coronary Arteries (GUSTO) trial studied 41,021 patients with acute myocardial infarction. It demonstrated a modest 14% reduction in mortality rate compared with streptokinase ($p=0.001$). In this trial treatment times for infusion of thrombolytics averaged 68 minutes.

c. Tenecteplase, 1999

The ASSENT-2 trial compared single bolus tenecteplase with front-loaded t-PA in 16,493 patients. After 30 days mortality rates were almost identical, but in patients treated after 4 h mortality rate was 7% for tenecteplase and 9.2% with t-PA ($p=0.018$).

In patients presenting within four hours of onset, speed of reperfusion is an organ, and connective tissue is a factor. Accelerated t-PA administration is preferred, particularly in patients at high risk: anterior MI, left

bundle branch block, diabetics and in patients with heart failure. In patients presenting within four hours from the onset of symptoms, the speed of reperfusion is of less importance and streptokinase has a role. Streptokinase is the logical choice in the young patient with an inferior myocardial infarction.

It does not appear to be logical to administer t-PA or tenecteplase to all patients based on the net clinical benefit and cost-effectiveness. The choice of tenecteplase, t-PA, or streptokinase is of little consequence to public-health worldwide, particularly when the real problem is the emergency room door-to-needle time. This is still inexcusably high at an excess of 30 minutes in more than 66% of patients admitted to the hospital in the United States.

4. Unfractionated Heparin

Unfractionated heparin has been used intravenously for the management of acute myocardial infarction for more than 40 years (see the chapter Anticoagulants). When t-PA or tenecteplase are administered, heparin must be used for a few days to prevent re-occlusion of the artery. Heparin is not required when streptokinase is used.

5. Low-Molecular Weight Heparin

Recent studies indicate that low molecular weight heparin given subcutaneously is as effective as unfractionated heparin given intravenously in the management of ST elevation MI and non-ST elevation MI, and may replace IV heparin. Several clinical trials have shown that these agents are effective and a safe alternative to intravenous heparin. They have been shown to improve clinical outcomes and to provide a more predictable therapeutic response, longer and more stable anticoagulation, and a lower incidence of an unfractionated-heparin-induced thrombocytopenia. Enoxaparin, however, appears to be the only low molecular weight heparin to have demonstrated sustained clinical and economic benefits in comparison with unfractionated heparin in the management of non-ST segment elevation MI.

6. Coronary Angioplasty/Intracoronary Stent

The rapid reopening of an occluded coronary artery by administration of thrombolytic therapy within three hours of onset of chest pain or reopening the artery mechanically

with PCI (balloon angioplasty and intracoronary stent) both provide beneficial improvements in mortality and morbidity in short- and long-term follow up. Several studies indicate that PCI may confer an improvement in outcomes compared with thrombolytic therapy in patients who present between 3 and 12 h after symptom onset. PCI with deployment of intracoronary stent has emerged as the treatment of choice for patients with ST segment elevation MI. Thrombolytic agents are used when facilities for PCI are not available or in selected patients.

XI. CLINICAL TRIALS

A. Meta-Analysis

A comprehensive meta-analysis involving 23 trials in 7739 patients demonstrated some superiority of primary PCI over thrombolytic therapy in reducing the individual end points of death, nonfatal infarction, and stroke. The risk of hemorrhagic stroke was significantly reduced by primary PCI.

The door-to-balloon time is the strongest predictor of outcome. A prospective registry of more than 27,000 patients undergoing primary PCI for acute myocardial infarction showed that in-hospital mortality significantly increased when the door-to-balloon time was delayed beyond two hours.

B. Danami-2, Andersen et al.

One of the first large randomized trials in assessing the benefits of primary PCI in patients with acute ST segment elevation infarction was done in Denmark.

Methods: Patients with acute myocardial infarction (1572) were randomized to treatment with angioplasty or accelerated treatment with intravenous alteplase.

Results: Among all patients the better outcome of angioplasty was driven primarily by a reduction in the rate of reinfarction (1.6% in the angioplasty group vs. 6.3% in the fibrinolysis group; $p < 0.001$). No significant differences were observed in the rate of death (6.6% vs. 7.8%; $p = 0.35$). Also 96% of patients were transferred from referral hospitals to an invasive treatment center within two hours.

This study showed a significant reduction in major adverse cardiac events: primary PCI group 8% versus 13.7%; ($p = 0.003$). This benefit was also observed in the 1129 patients who were transferred for primary PCI (8.5% vs. 14.2%; $p = 0.002$). The door-to-balloon time

in patients randomized to transfer was 115 minutes, only 10 minutes longer than in those who were brought directly to a PCI facility.

C. Prague-2

In the Prague-2 trial 850 patients with ST segment elevation infarction were randomized to immediate thrombolysis or transfer to a PCI facility. There was no significant reduction in 30-day mortality with transfer for primary PCI (6.8% vs. 10.0%; $p = 0.12$). Only the patients who presented later, between 3 and 12 h from onset of symptoms, showed a significant mortality benefit derived from the transfer of primary PCI versus immediate thrombolytic therapy (6.0% vs. 15.3%; $p = 0.02$). This study indicates that early thrombolytic therapy (less than 3 hours) from onset of symptoms may cause reperfusion comparable to those of primary PCI. This important observation requires confirmation from large randomized trials.

D. Captim

In this trial 840 patients were randomized to thrombolysis with t-PA administered by staff of a mobile unit followed by transfer to a PCI facility versus primary PCI. The door-to-balloon time was approximately 80 minutes in patients randomized to primary PCI with a coronary stent used in 75% of the patients. There was no significant difference in the causes of death or reinfarction and stroke between the prehospital thrombolysis and primary PCI (8.2% vs. 6.2%; $p = 0.29$). Also 26% of thrombolytic-treated patients required rescue PCI. If these data hold true in other large trials, it may become standard for ambulance crews to administer thrombolytics, and approximately 25% of these patients will require rescue PCI.

Conclusions: A strategy for reperfusion involving the transfer of patients to an invasive treatment center for primary angioplasty is superior to on-site fibrinolysis, provided that the transfer takes two hours or less.

XII. NON-ST ELEVATION MYOCARDIAL INFARCTION

A. Diagnosis

Non-ST segment elevation MI (non-Q-wave MI) is treated differently from acute myocardial infarction in which the ECG shows elevation of the ST segment (see Figs. 2 and 3). The diagnosis is made from the ECG pattern, and the

presence of elevated cardiac enzymes, particularly elevated troponins, assessed in blood samples taken on admission to the emergency room and 6 and 12 h later. The troponins are a more sensitive marker of cardiac necrosis than the CK-MB enzymes. Troponin testing represents a major advance in detecting micro-infarctions that may be missed by CK-MB.

The diagnostic ECG features include ST segment depression greater than 0.5 mm (in Europe it is greater than 0.1 mV, see Fig. 4).

B. Management

Figure 8 gives an algorithm depicting the management of non-ST segment elevation MI.

1. Beta-Blockers

A beta-blocking drug and intravenous nitroglycerin are administered to relieve pain and cause cardiac stabilization.

2. Platelet IIb/IIIa Receptor Blocker

Beta blockers are recommended for high-risk patients. Abciximab has proven beneficial after angiography in patients selected for immediate PCI. This drug has no role outside this indication. It proved more beneficial than

tirofiban in clinical trials. Eptifibatide and tirofiban are approved for PCI and for use during the wait before angiography. High-risk patients are most vulnerable during the first 48 h after admission awaiting PCI. Diabetic patients benefit the most from platelet receptor blocker therapy and benefit is maximal in diabetic patients when abciximab is used for PCI.

3. Clopidogrel

Clopidogrel combined with aspirin has been shown to provide short- and long-term benefits in patients undergoing PCI, in particular when intracoronary stents are used. A loading dose of clopidogrel 6–24 h prior to PCI is advisable (see the chapter Antiplatelet Agents). Clopidogrel is withheld in patients in whom bypass surgery is planned to prevent excessive hemorrhage.

XIII. COMPLICATIONS OF MYOCARDIAL INFARCTION

A. Arrhythmias

1. Tachyarrhythmias

The most malignant arrhythmia, ventricular fibrillation, is most common during the first four hours of infarction

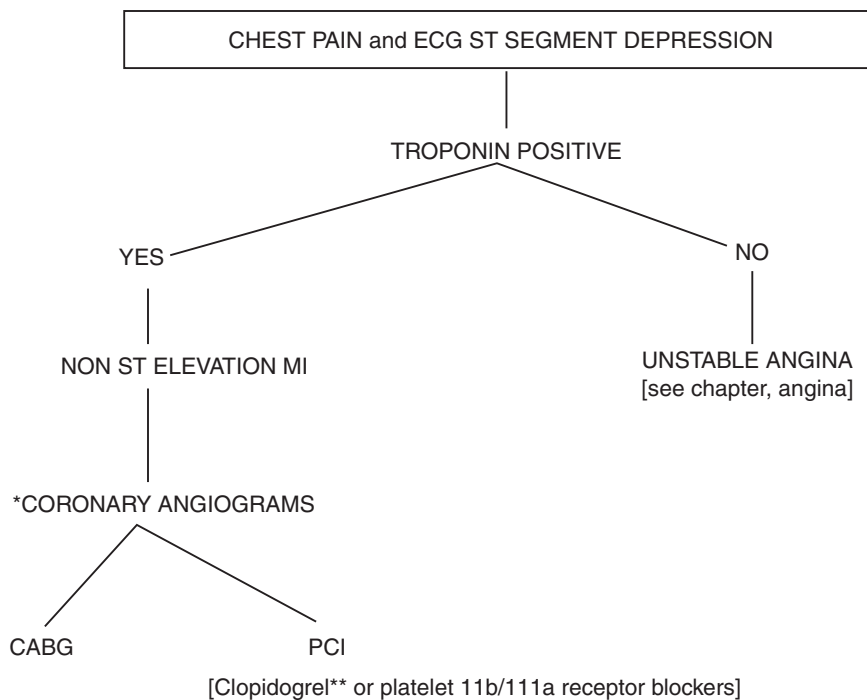

FIGURE 8 Management of non-ST elevation myocardial infarction (MI). * = Virtually all patients should receive coronary angiograms to direct suitability for PCI or coronary artery bypass graft (CABG). ** = Loading 6–12 hours prior.

occurring in about 5% of patients and in about 0.4% of those admitted later. Ventricular fibrillation may occur without a warning arrhythmia and in the absence of heart failure or cardiogenic shock. This malignant arrhythmia may occur despite an adequate suppression of ventricular premature beats. Warning arrhythmias are seen frequently in those who have ventricular fibrillation as well as in those that who don't. Thus, ventricular fibrillation cannot be accurately predicted.

It is possible that when ventricular fibrillation is precipitated by early occurring ventricular premature beats, R-on-T phenomenon, the ventricular fibrillation threshold at that time has been decreased by certain factors. These include myocardial ischemia, tachycardia, hypoxemia, alkalosis or acidosis, hypokalemia, or catecholamine release in the area of infarction that increases cyclic adenosine monophosphate activity, which is believed to facilitate the development of ventricular fibrillation.

The use of prophylactic lidocaine to suppress ventricular premature beats has been abandoned. The early administration of beta-adrenergic blockers should suffice for most patients with ventricular premature beats. This strategy has been shown to reduce the incidence of ventricular fibrillation and death from acute infarction.

Atrial fibrillation or supraventricular tachycardia with a fast ventricular rate precipitating hemodynamic deterioration is converted electrically using low energy shock. If there is no hemodynamic disturbance, the short-acting beta-blocking agent esmolol may be used to slow the ventricular rate.

2. Bradyarrhythmia

Bradycardia with heart rates of 48–60 beats per minute is common and occurs with acute inferior infarction and is usually not harmful. Severe bradycardia at less than 48 beats per minute causing hemodynamic compromise such as hypotension or ventricular ectopy is managed with small doses of atropine to increase the heart rate to a maximum of 60 beats per minute. Bradycardia associated with second-degree type II AV block and complete heart block unresponsive to atropine usually requires temporary pacing.

B. Heart Failure

I. Diuretic

Mild left ventricular failure occurs during the first 24 h of acute myocardial infarction, particularly if the area of infarction is large. Mild heart failure usually responds to

administration of small doses of the diuretic, furosemide, given 20–40 mg daily for a few days. Serum potassium must be maintained at a level greater than 4.5 mEq/L. The administration of morphine relieves symptoms of heart failure and allays anxiety.

2. Nitrates

More severe degrees of heart failure are managed with the above measures and the addition of intravenous nitroglycerin or isosorbide dinitrate. Nitrates are useful to reduce preload when pulmonary congestion is present with a high pulmonary wedge pressure.

3. ACE Inhibitors

ACE inhibitors are administered to virtually all patients with heart failure and those with left ventricular dysfunction manifested by an ejection fraction of less than 40%. These agents reduce morbidity and mortality in patients with heart failure caused by myocardial infarction (see the chapter Angiotensin-Converting Enzyme Inhibitors/Angiotensin Receptor Blockers).

4. Beta-Blockers

The beta-blocking agent carvedilol gave excellent results in the CAPRICORN study. Patients with acute infarction and ejection fractions less than 40% treated with an ACE inhibitor were randomly assigned and the treatment arm received carvedilol 6.25 mg increased progressively to 25 mg twice daily. Carvedilol caused a significant 23% reduction in all-cause mortality in patients followed for 2.5 years. The absolute reduction in risk was 23%. This reduction in mortality by carvedilol occurred in addition to reduction caused by ACE inhibitors alone.

C. Right Ventricular Infarction

This common acute inferior infarction is accompanied by right ventricular infarction in proximity 40% of patients. These patients are observed to have a high mortality rate: 31% mortality and 64% in-hospital complication versus 6% and 20%, respectively, for those with pure inferior infarctions. Management is difficult and includes plasma volume expansion combined with inotropic agents such as dobutamine. The conventional treatment for heart failure with diuretics and nitrates is harmful and contraindicated in right ventricular infarction because these agents reduce preload and filling of the ventricle. Thrombolytic therapy

is strongly indicated but PCI is strongly advisable because mortality can be reduced by this strategy.

D. Risk Assessment for Long-Term Outcome

Echocardiography and low-level exercise testing are performed prior to discharge. The echocardiogram gives an approximate assessment of the ejection fraction which may indicate mild, moderate, or severe left ventricular dysfunction. Exercise testing after acute infarction is usually done between days five and six often using a low-level exercise protocol. The results of these tests allow the physician to give guidance to the patient regarding activities, rehabilitation, sexual activity, and approximate date of return to employment.

1. Left Ventricular Dysfunction

The mortality rate during the first year following a myocardial infarction is inversely related to left ventricular systolic function. The risk for death increases dramatically in patients with ejection fractions less than 30% and is largely caused by a larger size of infarction and malignant ventricular arrhythmias. The ventricular ejection fraction is the single most powerful predictor of mortality and the risk for malignant, life-threatening ventricular arrhythmias during the first two years following myocardial infarction. Antiarrhythmic agents have been shown to increase mortality in this subset of patients and implantation of a cardioverter defibrillator (ICD) in selected high-risk patients with ejection fractions less than 30% with non-sustained ventricular tachycardia and inducible sustained ventricular tachycardia is undergoing trials. Currently, in this high-risk subset of patients the combination of the beta-blocking drug carvedilol and an ACE inhibitor along with spironolactone or eplerenone improves survival.

2. Lethal Arrhythmias

Lethal, malignant arrhythmias account for approximately 50% of deaths during the first two years following infarction. The risk associated is related to the timing of the ventricular ectopy following infarction. Ventricular ectopy occurring during the first 24 h is not predictive of long-term outcome. The longer the period between the infarction and the occurrence of ventricular arrhythmia and the longer the duration of the arrhythmia, the greater the attributable risk. Patients with nonsustained ventricular tachycardia and three or more consecutive beats are at a greater risk than those with a similar frequency of isolated

ventricular premature beats or occurrence of paired beats (couplets).

3. T Wave Alternans

Microscopic T wave alternans characterized by microvolt changes in contour, amplitude, or polarity of the T wave unaccompanied by gross changes in cycle length, usually every other beat, appears to be the result of cellular and molecular alterations associated with repolarization heterogeneity. Small studies have indicated a relationship between T wave alternans and serious arrhythmias. These studies, however, have shown the specificity and positive predictive value of the test to be lower than the finding of a low ejection fraction (<30%) or nonsustained ventricular tachycardia.

In a study of 379 consecutive patients following acute infarction, T wave alternans was not present in any of the patients who died during follow up. It appears that the test is less sensitive in the presence of beta-blocking drugs, which must be used in patients following infarction. The value of this test is being assessed in ICD clinical trials.

XIV. HEART ATTACK AND EMOTIONAL IMPACT

For most people, suffering a heart attack is a traumatic mental experience. Uncertainty about the financial impact, the work situation, relationships, and in particular, sexual activity may cause depression and anxiety. Social workers, nurses, and the medical team must find time to listen and talk to the patient. Explanations and answers must be clear so that the patient understands that, after a heart attack, a normal life can be possible. The sophisticated gadgets of modern medicine cannot replace the reassuring words of an understanding, caring physician.

Reassurance is important not only to the patient but also to the patient's family. The patient's relatives are often in distress and must receive adequate counseling from the nursing staff, medical health staff, and the physician in charge. During the entire hospital stay, a few minutes spent each day with relatives to answer questions is most rewarding and greatly appreciated.

XV. DEPRESSION AND ANXIETY

The majority of heart attack patients experience some degree of depression and anxiety. To combat this complication, both the doctor and the nurses must

communicate with the patient in an open and frank manner so that the patient can air feelings and have all questions answered during the time in the hospital. A social worker may have to be involved in some cases, and supportive home visits, advice on job orientation, and discussions regarding financial matters may be necessary. Two weekly visits to an understanding family doctor may help to dissipate depression with the recognition that all is not lost. The doctor should reassure the patient that depression and anxiety with the associated weakness and tiredness are normal and will be alleviated with time. It takes six weeks for the damaged muscle to heal and form a firm scar. During the same six weeks, anxiety and depression dissipate in the majority of patients. The first four weeks will be tough. Thereafter, the assistance of an exercise program, the ability to drive again, and the return of sexual activity may help to lift the despair. Time heals all wounds, including the muscle damage and psychological insults. A few (less than 1% of patients) require antidepressant drugs. These are nonaddicting and can be very useful when given as a single bedtime dose for 3 to a maximum of 12 weeks. An exercise rehabilitation program is useful in many respects and is of definite assistance in the management of most heart attack patients (see the chapter Depression and the Heart).

XVI. DIET AFTER A HEART ATTACK

A low-salt diet is prescribed only for patients with heart failure who require water pills (diuretics) or digoxin, as well as for the previously hypertensive patient (see Table 3). Patients are advised on the use of a weight-reduction diet and a modified diet to reduce cholesterol and saturated fat intake. Lipid-lowering drugs are administered to patients who have an LDL cholesterol greater than 100 mg/dl (2.5 mmol).

The total cholesterol, LDL, and HDL cholesterol are estimated for the patient in the hospital and three months later. The goal is to maintain the LDL cholesterol at less than 100 mg/dl (2.5 mmol; see section XXIII). Alcohol should be avoided for the first four weeks; thereafter one to two ounces daily are allowed. Alcohol is restricted if heart failure is present or if the heart is enlarged.

XVII. REHABILITATION, RETIREMENT, AND TRAVEL

Most patients under age 65 can return to work between 6 and 12 weeks after discharge. The return date takes into account the patient's age, financial resources, existing

TABLE 3
List of Foods with Comparative Sodium (Na) Content

Food	Portion	Sodium (mg)
Bacon back	1 slice	500
Bacon side (fried crisp)	1 slice	75
Beef (lean, cooked)	3 oz (90 g)	60
Bouillon	1 cube	900
Garlic powder	1 tsp (5 ml)	2
Garlic salt	1 tsp	2000
Ham cured	3 oz (90 g)	1000
Ham fresh, cooked	3 oz	100
Ketchup	1 tbs	150
Meat tenderized regular	1 tsp	2000
Meat tenderized low Na	1 tsp	2
Milk pudding instant whole	1 cup (250 ml)	1000
Olive green	1	100
Peanuts, dry roasted	1 cup	1000
Peanuts dry roasted, unsalted	1 cup	10
Pickle dill	Large (10 × 4 1/2 cm) 1 (50 g)	1900
Wieners		500
CANNED FOODS		
Carrots	4 oz	400
Carrots raw	4 oz	40
Corn whole kernel	1 cup	400
Corn frozen	1 cup	10
Corn beef cooked	4 oz	1000
Crab	3 oz	900
Peas cooked green	1 cup	5
Salmon salt added	3 oz	500
Salmon no salt added	3 oz	50
Sauerkraut	1 cup (250 ml)	1800
Shrimp	3 oz	2000
Soups (majority)	1 cup (250 ml)	1000
Salad dressing		
Blue cheese	15 ml	160
French regular	15 ml	200
Italian	15 ml	110
Oil and vinegar	15 ml	1
Thousand Island	15 ml	90
FAST FOOD		
Chopped steak	1 portion	1000
Fried chicken	3-piece dinner	2000
Fish & chips	1 portion	1000
Hamburger	double	1000
Roast beef sandwich	1	1000
Pizza	1 medium	1000

The normal diet contains 1000 to 3000 mg sodium. Daily requirement is less than 400 mg.

diseases, and type of work. The physical and emotional stress associated with the job should be thoroughly explored.

Patients with uncomplicated myocardial infarctions are advised to increase activity and return to about 90% of the preinfarction level in three months. If at 6–10 weeks the exercise stress test and ejection fraction (the volume of blood the heart pumps) are satisfactory, the patient's prognosis should be excellent. Types of exercise are discussed in the chapter Exercise and the Heart. Exercise at home should be graduated. During the first three days at home, walk in the house and for the remainder of the first week, walk outside the home 50–100 yards daily. During the second week walk 200 yards once or twice daily. In the third week cover 300 yards once or twice daily. During the fourth week go a quarter mile or 440 yards once or twice daily. In the fifth week, walk a half mile daily, and during the sixth week, walk one mile once or twice daily. This is a rough estimate of what you should be doing during the first six weeks after a heart attack. Thereafter, if you feel well and have no chest pain, you should be able to do more exercise such as joining an exercise program. One- to three-mile walks are usual by the eighth week post myocardial infarction. Doubles tennis, golf, and similar past times are reasonable at three months.

Patients may join supervised exercise programs provided there is no evidence of persistent heart failure, angina, abnormal heart rhythm such as frequent premature beats (see the chapter Arrhythmias/Palpitations), and moderate to severe problems with heart valves. A stress test is useful at some point, especially if you want to do different activities. In patients under age 70, a stress test done between the 6th and 10th week should result in the patient being able to do more than seven minutes of walking on the treadmill. Patients who can complete about nine minutes without undue shortness of breath, chest pain, or ECG changes, which indicate oxygen lack to the heart muscle, are usually allowed to engage in all exercise activities. Competitive sports and extreme exertion should be avoided. Patients who can complete six minutes, but need to stop because of fatigue, tiredness, or leg discomfort and who show a normal heart rate and blood pressure without an abnormal heart rhythm or ECG changes, are allowed to participate in a restricted and, if possible, supervised exercise program, but they should be retested in three months. Exercise programs should be individualized. There are many useful rehabilitation programs attached to major hospitals. Provided that adequate supervision is obtained, exercise programs play a great role in assisting patients to maintain good body tone and to return to

participation in games, sexual activity, and the work they were accustomed to before a heart attack.

Exercise programs are strongly advised provided that the patient is stress-tested and conditions that contraindicate exercise programs are reviewed by the physician for each individual. There is no evidence that moderate to strenuous exercise prevents heart attacks or limits the size of a heart attack. The physician should recognize the minority of patients in whom a very gradual program or only mild exercises are appropriate. Walking certainly provides safe and adequate exercise.

Because you have had a heart attack, it does not mean that you will be crippled for life. About 10 million North Americans can testify that you can recover from a heart attack and go on to live a very active and normal life. The majority return to the same job. Within three to six months, the majority engage in the same activities they did prior to the heart attack. Tennis, golf, and skiing are only a few of the many activities that are enjoyed. Some individuals lead a more active life and learn to handle stress better and often report that they feel better than 10 years prior to their heart attack. If you like jogging, you should know that six months after their heart attack, more than 50% of patients are able to jog one to three miles daily. We are not suggesting that you do this, but if you enjoy jogging, then one to two miles four times weekly will improve your endurance. Similar exercises including a one- to three-mile walk and stair climbing are suitable activities.

A. Don'ts

- Do not do static exercises such as weightlifting or push-ups. Such exercise uses sustained muscular contraction that squeezes the blood vessels, and thus increases blood pressure and the work of the heart.
- Do not exercise immediately after a meal. Wait one to two hours after a light snack or two to three hours after a heavy meal. Do not exercise if you have a fever.
- Do not stop exercising suddenly; always warm up and cool down for 5–10 minutes.
- During the first six weeks at home, do not engage in strenuous exercise or housework such as heavy cleaning or repairs, gardening such as raking leaves or mowing the lawn, or snow shoveling.
- Do not take a hot or cold shower immediately before or after exercise. Do not take a sauna because the heat dilates the vessels in the skin and steals blood away from the heart and the brain.

XVIII. RETIREMENT AND TRAVEL

A. Retirement

Retirement may well be a problem for many individuals, especially those who do not have enough hobbies to keep them sufficiently occupied. Often individuals become bored and depressed, therefore, retirement must be selective. If possible, it is best to get back to work because this prevents the development of neurosis and depression. There is no doubt that returning to a job that was previously distressing can lead to further harm. Patients who can afford to change jobs or retire and have enough hobbies do extremely well. The good news is that the disease may burn itself out. Individuals who have had large heart attacks with complications such as severe heart failure that restrict exercise programs are strongly advised to retire, especially if they are over 65. A change in lifestyle may be lifesaving.

B. Travel

Patients should not drive for about six weeks. If a stress test is satisfactory at three weeks, necessary flying is allowed, otherwise elective flights should be postponed beyond three months. Patients with stable angina are allowed to fly any time, but not if angina is unstable (see the chapter Angina). Patients should take along a current ECG tracing. This may save unnecessary admission to a hospital and provide a physician with a prior ECG for comparison. Nitroglycerin should be carried, too, along with all medications advised by the doctor. Oxygen is not necessary during the flight.

XIX. SEXUAL ACTIVITIES

Sex is a part of living. For the majority, it is one of the most enjoyable, satisfying, stress-relieving activities that life provides. Most of what is said regarding heart attacks and sexual activity relates to men, because the heart attack rate is far more common in men than women at age 35–65. Also, men have far more hang-ups about sex than women, especially because a man cannot will an erection. Fear interferes with performance; thus some men, due to a lack of proper discussion with their doctor before hospital discharge, develop fears that may cause problems with sexual function. In addition, the female partner develops fear and apprehension that intercourse could cause the death of her husband. The female partner may therefore

turn the whole thing off. This disturbance in a marital relationship can be quite traumatic and increase the anxiety and depression that is so common after a heart attack.

It is important for males to understand that a heart attack does not cause impotence, and that if you do not have intercourse for six weeks, it will not alter sexual performance in the future. The good news is that 12 weeks after a heart attack, more than 75% of patients are able to engage in sexual intercourse with the same frequency as before. A heart attack is not the end of your sex life. Some physicians believe that sex can be resumed about two weeks after discharge from the hospital, but the majority of physicians agree that it is reasonable and safe to resume intercourse about six weeks after a heart attack. There is no hard and fast rule; you should do what comes naturally and without fear. If, about four weeks after discharge, you are able to walk one mile and climb two flights of stairs without chest discomfort or undue shortness of breath and experience the urge to have sex with your usual partner, then you should go ahead without fear of precipitating another heart attack.

The amount of physical exertion required during sexual intercourse is equivalent to walking up about four flights of stairs or a brisk one-mile walk. Most heart attack patients should be engaging in this type of exercise about six weeks after a heart attack anyway. If during such activity there is no chest discomfort or undue shortness of breath, sexual activities are considered safe. In a study of 6000 cases of sudden death, only 34 were related to sexual intercourse and 27 of those deaths occurred during extramarital sexual relations.

Most deaths in males during intercourse occur while engaging with partners other than their wives. Middle-aged males who have been married for a number of years are at greatest risk. Intercourse with a much younger extramarital female partner may lead to more emotional reactions, causing a much higher increase of blood pressure and heart rate, thus putting the heart under severe strain. Furthermore, such a moment may also be accompanied by the ingestion of a large meal and alcohol, which adds to cardiac work. Sudden death or heart attack is extremely rare when the heart attack patient engages in intercourse with the usual partner.

It is advisable to use the sexual position to which you are most accustomed. There is no reason to change to side-to-side or female on top if this was not the most often practiced and most favorable position. If the patient is male and erection is easily achieved, the female on top — superior crouched — is often recommended. In this position, the woman has both knees touching the bed for

traction; therefore, she is the active partner. What is most familiar is always the best position as it increases confidence in the male and allays anxiety in the female, who is afraid that the husband may die or have a heart attack during intercourse. There is no need to decrease the frequency of sexual activity. After three months if there is no chest pain, undue shortness of breath, or palpitations on walking two to three miles or climbing four flights of stairs or jogging one mile, the individual should be capable of enjoying the same sexual frequency as before the heart attack. Drugs such as sildenafil should be avoided for the first 3 months and until stress tests indicate absence of significant ischemia. Nitroglycerin or nitrates must be avoided if sildenafil or similar agents are used.

A. Don'ts

These apply to the first three months after a heart attack and for patients with chest pain on effort (angina) or heart failure:

- Do not take a hot shower immediately before intercourse. Hot showers or saunas dilate vessels of the skin, thus stealing blood from the heart and the brain.
- Do not have intercourse immediately after a heavy meal; wait two to three hours.
- Do not have more than one drink of alcohol or beer and indulge in intercourse. More than three drinks consumed in two hours will make it more difficult to achieve an erection and may also decrease heart muscle contraction.
- Smoking can also decrease sexual performance. Smoking has been shown to cause constriction of small penile arteries and therefore impotence.

B. Suggestions

A simple exercise program improves physical endurance and nearly always increases sexual performance. Therefore, start your walking program one week after discharge and increase it to a brisk one- to two-mile walk daily by the sixth week. Each week increase from one, then two, then three flights of stairs by the sixth week. If your hospital or community offers a rehabilitation program, it is wise to join this with the advice of your cardiologist, or plan your own program with some common sense. At this stage, you should know how to take your pulse and try to keep the heart rate for about five minutes within the target zone, i.e., 60–70% of your maximal heart rate. After a few months of exercise, if you feel well, you can keep the heart

rate in the target zone for about 5–10 minutes during 30 minutes of exercise. A stress test at this stage may increase your confidence, and your physician can advise on additional exercises.

Rest is more important before rather than after sexual activity, although if you feel tired after the activity and feel like sleeping, certainly it is wise to have a 30- to 60-minute rest. Therefore, if possible, have intercourse in the morning after a night of sleep or any other time after rest or relaxation. If you are very short of breath or develop chest discomfort during intercourse, stop and take nitroglycerin. Discomfort during your first sexual experience does not mean the discomfort may occur again. It also does not indicate that you are likely to develop a heart attack during intercourse. However, if pain does recur or if there is any difficulty with sexual activity, be sure to discuss this with your doctor at the next office visit. Medications given on discharge may interfere with sexual performance, and these may be reduced at your next office visit. Diuretics (water pills), beta-blockers, antihypertensive drugs, or antidepressants can alter sexual performance (see the chapter Erectile Dysfunction and the use of sildenafil).

XX. BETA-BLOCKERS

Beta-blocking drugs were discussed in the chapter Angina, and the present discussion explains the rationale for their use in patients after a heart attack. Beta-blockers block the action of adrenaline and noradrenaline at receptor sites on the surface of cells. They cause a reduction in heart rate; therefore, less oxygen is required by the weakened heart muscle. They decrease the force of contraction of the heart muscles, and this further decreases the work and the amount of oxygen required by the heart. Most of the effects on the heart and arteries are related to this blocking of the actions of stress hormones. Beta-blockers stabilize the heart rhythm and can prevent premature beats such as those that are precipitated by mental and physical stress. They can prevent some episodes of ventricular fibrillation, which is the cause of sudden death.

Beta-blockers, statins to lower cholesterol, and aspirin are the only oral drugs that are proven by studies to prevent death from heart attacks. When beta-blockers are given to patients from day one after a heart attack and for up to two years, they significantly reduce the incidence of death from heart attack including sudden death. They also reduce the recurrent rate of subsequent heart attacks. About 70 of every 100 heart patients are eligible for treatment with beta-blockers, and these include patients who have angina after the heart attack.

In the UK, a survey of actively practicing British consulting cardiologists was carried out to determine their practices when prescribing beta-blockers after a heart attack. Half of the cardiologists reported that they use beta-blockers in all patients who can take the drug starting about one week after the heart attack and continuing for about two years. The other half reported that they gave the beta-blockers to patients at high risk. It is strongly recommended to give a beta-blocker to all post heart attack patients from day seven if there is no contraindication to their use.

Despite the proven beneficial effects of beta-blockers in preventing death and infarction, less than 33% of patients received beta-blockers from their physicians from 1985 to 1995. Currently about 66% of patients receive beta-blocker therapy. More than 50% of the physicians in North America are reluctant to prescribe the drugs for patients after a heart attack. This reluctance stems from the teaching of a minority of experts and failure to update their knowledge.

The argument of the physicians who oppose the routine use of beta-blockers is as follows: Although the beta-blocker timolol has been shown to cause a 33% reduction in cardiac deaths and a 67% reduction in sudden deaths in a well-run multicenter randomized clinical trial, a 33% reduction means that of every 100 patients with a heart attack treated with a beta-blocker, “only” 3 lives can be saved. That is, if you take 100 heart attack patients discharged from the hospital, studies have established that 10 patients will die in the next year and 33% of the 10 deaths can be saved (three patients). Thus these physicians believe that it is not worthwhile to treat 100 patients with a beta-blocker to save only three.

Some physicians use expensive, sophisticated tests to determine high-risk patients who are likely to die in the next year. Beta-blockers are then given to the few patients who are considered high-risk. Prediction by tests, especially stress tests, nuclear scans, and Holter monitoring, can be misleading, however.

To these opposing physicians, the following question is posed: The next 20 years of extensive and expensive research may produce a medication capable of a 60% reduction in deaths in patients who have had a heart attack and then treated for one year. This result will be accepted by all physicians as good news. If the majority of physicians will then agree to treat 100 to save 6, why not treat 100 to save 4 at present? Is the difference between six and three patients that great? The new drugs for dissolving blood clots soon after a heart attack save 2 to 5 lives in every 100 patients treated, and this is considered a major achievement. Logical therapeutic decision making and application of common sense in prescribing

proven remedies appear to be a worldwide weakness of physicians.

The dose of a beta-blocker used for the prevention of death and recurrent heart attacks is not high and side effects are infrequent. A fall in pulse rate from the usual average 70 beats per minute to 55 beats per minute is expected if the drug is working. On mild to moderate exercise the heart rate stays under 120 beats per minute as opposed to racing to 140–150 beats with a moderate amount of exercise. The slowing of the pulse is a good effect; therefore, do not be afraid of a heart rate of 50–60 beats per minute. Only a few patients, less than 10%, get symptoms of dizziness if the pulse falls below 50 beats per minute. The dose of drug is then reduced by half and the pulse stabilizes between 54 and 64 beats per minute. In a few patients, the drug has to be discontinued because too much slowing may occur on a very small dose. Fortunately these sensitive patients are rare (less than 1%).

The commonly used beta-blocking drugs are

- Propranolol: 40 mg twice daily for two weeks then 80 mg twice daily for one month followed by 160–240 mg long-acting once daily in nonsmokers
- Metoprolol: 50 mg twice daily for two weeks then 100 mg twice daily or Toprol XL, 50–100 mg once daily, is a major advance; Toprol XL is unfortunately not available in Canada
- Carvedilol has proven effective after heart attacks and in patients with left ventricular dysfunction at a dosage of 12.5–25 mg twice daily
- Timolol: 5 mg twice daily for a few weeks then 10 mg twice daily
- Atenolol: 50–75 mg daily; a 25-mg tablet is available in the United States and is useful in the elderly; *this agent has not been proven to prevent fatal or non fatal infarctions but is widely used* (see the chapter Beta-Blockers)
- Bisoprolol 5–10 mg daily

Many other beta-blockers are available, but the ones listed above have been shown to be useful in post heart attack patients. Propranolol may not confer protection in smokers. It is important, therefore, to also discontinue smoking.

If you notice side effects, especially wheezing, increased shortness of breath, dizziness, or impotence reduce the daily dose of beta blocker by half and consult your doctor. Do not stop the drug suddenly. Impotence is very rare but does occur in about 4 in every 100 patients treated. Heart attacks do not cause impotence but can decrease sexual activity; therefore it may not be the prescribed drug. In any event, alteration in sexual activity should prompt the doctor to reduce the dose of beta-blocking drugs. If there is no improvement, the beta-blocker may be

discontinued and the effect on sexual function is quickly reversed.

The use of beta-blocking drugs can save between 40,000 and 100,000 lives annually in the United States and Canada, and many nonfatal heart attacks can be prevented. This information has been available since 1981. We trust that physicians would want to smarten up and use this lifesaving drug.

XXI. EPLERENONE (INSPIRA)

In the EPHEBUS study reported by Pitt et al., eplerenone, a selective aldosterone blocker, administered to patients with left ventricular dysfunction after myocardial infarction proved beneficial. In the study 3313 patients were randomly assigned eplerenone, 25 mg daily to a maximum of 50 mg or placebo and 3319 patients were administered optimal medical therapy.

Results: During a mean follow up of 16 months, there were 478 deaths in the eplerenone group and 554 deaths in the placebo group ($P=0.008$). There were 407 cardiovascular deaths in the eplerenone group and 483 in the placebo group ($P=0.005$). The rate of death from cardiovascular causes or hospitalization for cardiovascular events was reduced by eplerenone ($P=0.002$), as was death from any cause or any hospitalization ($P=0.02$). The rate of sudden cardiac death was significantly reduced ($P=0.03$). The rate of serious hyperkalemia was 5.5% in the eplerenone group and 3.9% in the placebo group ($P=0.002$). The rate of hypokalemia was 8.4% in the eplerenone group and 13.1% in the placebo group ($P<0.001$).

Eplerenone possesses the beneficial actions of spironolactone without the drawback of gynecomastia. This drug is not advisable in patients with a serum creatinine of >1.1 mg/dl because hyperkalemia may be precipitated.

XXII. CASE HISTORY OF A HEART PATIENT

O.W., age 47, was sitting watching television when he suddenly felt a pain in the center of his chest. The pain felt like nothing he had ever experienced before. The entire lower two-thirds of his breastbone and part of his left chest felt as if someone was crushing him in a vice. He started to feel weak and afraid, and he loosened his collar to relieve the feeling of strangulation. He called his wife for some antacid for what he assumed must be terrible indigestion due to the high-fat meal he had eaten 30 minutes earlier. Two antacid tablets did not relieve the pain and he started

to pace restlessly around the room. He soon became dizzy, felt faint and was forced to lie down. The pain was not relieved by lying flat, so his wife propped him up and started rubbing his back. About 7–10 minutes went by and the pain was becoming worse; he felt as if he was going to die. Though a sense of panic was beginning to set in, he did not want to alarm his wife. His entire life seemed to float before him. He was determined to sit up and to walk to see if it would ease the pain. He moved across the room. The dizziness was less than before, but the pain was of the same intensity. Both arms, from the shoulders to below the elbows, were now aching as if he carried a 50-pound weight in each hand. There was no pain in his back. He tried to analyze what could be the reason for this pain. He had not done any physical work in the past month. It could easily be stomach upset because there was some discomfort at the lower end of his breastbone and stomach (epigastric area). He had been under pressure at work for the last month. His job was on the line and he was determined to show his colleagues and boss that he could cope. He had faced similar stressful situations before. Suddenly, as he was wondering about the past, the pain became excruciating, constricting his chest. He could no longer hide his fear. His wife noticed his face had become pale. She dashed for the phone and called an ambulance, which came 20 minutes later. The wait was agonizing as his breathing and the strangling sensation worsened. He had no nitroglycerin in the house because he was not known to have coronary heart disease. As soon as the ambulance arrived an oxygen mask was applied and he was rushed to the emergency room of the nearest hospital. A diagnosis of acute myocardial infarction was made and he was admitted to the CCU of the hospital. He made a reasonable recovery and was discharged on the 10th hospital day. He did have mild heart failure during the first two days in the hospital but this cleared quickly. A few days after his attack, he was placed on a beta-blocker, propranolol, and a drug to try to prevent blood clotting, sulfapyrazone. He discontinued his two-pack-a-day smoking habit. His cholesterol was 1.3 mmol (280 mg), which is moderately elevated. He was not overweight but he was placed on a diet with low cholesterol, low saturated fat, and moderate salt restriction. He was placed on an exercise program. He had liked jogging in the past, and three months after his heart attack he was able to jog one to three miles daily.

He did well for the next two years, during which time he took his medications regularly. He continued his exercise program doing 3–10 miles daily, 6 days weekly. About 18 months later, while standing in line at the bank. He suddenly dropped to the floor. Fortunately, a trained nurse was in the line and CPR was commenced. He was

resuscitated and rushed to the hospital. He was found to have complete heart block, and a permanent pacemaker was inserted. He was discharged from the hospital a few days later and resumed his daily exercises.

About one year later, while on vacation, he suddenly experienced central chest pain that was similar to his first heart attack and he was rushed to the hospital. His attack was complicated by heart failure. His heart failure was cleared by the use of digoxin, furosemide, and a vasodilator called captopril. Investigations showed that he had developed an aneurysm, a small swelling of part of the heart muscle.

He wanted to get back on an exercise program. At this stage he was not the best candidate for exercise, so he started slowly over the next few weeks by walking one to three miles. He eased into jogging a quarter mile daily, but when he tried to do a half mile, he started getting shortness of breath and pain in the chest. This pain was immediately relieved by stopping the run. Angina was present and he now agreed to have a catheter study. Coronary arteriography was done, and this showed a complete block in one artery, more than 80% obstruction in two branches, and a small aneurysm of the left ventricle. He underwent coronary artery bypass surgery with three bypass grafts and repair of the aneurysm. Two weeks later he was discharged from the hospital. He slowly began an exercise program, and 10 months later he was once again jogging one to two miles daily. He completed the Terry Fox 10 km Fun Run in September 1985 and 1990. In the late 1990s he enjoyed a normal lifestyle but developed atrial fibrillation and sick sinus syndrome requiring a pacemaker. He remains active today.

XXIII. RISK FACTORS AND PREVENTION

The identification of factors that increase the risk of heart attack has been made possible by various population studies including the well-known Framingham Study. Its statistical correlation has been consistent enough to enable researchers to state with confidence that high blood cholesterol, high blood pressure (hypertension), and cigarette smoking are major risk factors and, if present, increase your probability of having a fatal or nonfatal heart attack or stroke. These risk factors can be subdivided into three groups.

Group I: Uncontrollable Risk Factors

1. Heredity: A strong family history of heart attack especially before age 55 increases the risk.
2. Age: Risk increases with age.
3. Sex: Everyone recognizes that heart attacks are about 10 times more common in men than in women in the

35–50 age group. After menopause and beyond age 70 women catch up.

Group II: Controllable Risk Factors

1. High blood cholesterol, LDL cholesterol
2. Hypertension
3. Cigarette smoking
4. Stress

Group III: Other Factors of Importance

1. Diabetes (see the chapter Diabetes)
2. Sedentary lifestyle, lack of exercise
3. Strenuous unaccustomed exertion
4. Obesity
5. Type A personality
6. Two or three fruits and vegetables daily

High blood pressure (hypertension) is a preventable risk factor. It is extremely difficult to get the population at risk to discontinue smoking. Hypertension, however, can be detected and does respond to nondrug treatment, and where this fails, safe and effective drugs are now available (see the chapter Hypertension).

It is well established that hypertension increases the risk of heart attacks, especially if there is concomitant high blood cholesterol and/or cigarette smoking. Hypertension causes mechanical damage to the lining of the artery, and cholesterol is drawn into the injured tissues. There is conclusive scientific evidence that control of hypertension markedly lowers the incidence of stroke, heart failure, and kidney damage, and it is believed to decrease the incidence of fatal and nonfatal heart attacks. Hypertension accelerates atherosclerosis, and blockage or rupture of an artery occurs from 10–20 years earlier than in individuals with normal blood pressures.

In recent years, heart attacks have been observed in males age 27–34, but this occurrence is rare. Such males usually have a very high blood cholesterol, hypertension or rare diseases of the coronary arteries, and a family history of heart attack before age 50. Heart attacks before age 27 are extremely rare and may occur in patients with familial hypercholesterolemia who have a cholesterol in the range of 600–1000 mg (15–25 mmol). Menstruating females are often protected from heart attacks, except those who smoke and simultaneously take birth control pills or those with diabetes, hypertension, and rare familial hypercholesterolemia. Family history is important. Individuals with a strong family history, that is, a parent and one or more uncles or aunts dying of heart attacks before age 55, have an increased risk. These individuals should have a medical checkup, including total cholesterol, LDL (bad) cholesterol, and HDL (good) cholesterol measurements at about

age 25. The advice of a physician is required if the LDL is less than 4 mmol and HDL is less than 1 mmol. A stress test at about age 40 is appropriate if the cholesterol is borderline.

If you are a male over age 35 and have one of the four major risk factors — high blood cholesterol, hypertension, cigarette smoking or stress — your chance of having a heart attack doubles. Two risk factors increases your risk to more than three times that of a person with no risk factors. If you have all four and your mother or father had a heart attack prior to age 55, your risk increases to about seven times. No one can predict with any degree of certainty who is going to have a heart attack. Some people are just plain lucky. They have the correct genes, they disobey all the rules, they never exercise, and they lead a stressful life and yet never have a heart attack. People of this type are not overweight, and fortunately have blood pressures that are on the low side of normal (110–120 systolic). If your blood pressure is low (less than 120/80), and you are average or slightly underweight and your parents both lived to beyond 75, you are on the right side of the track. Women are at risk after age 55 and need preventive measures from at least age 48 (see the chapter Women and Heart Disease).

XXIV. HEART ATTACK PREVENTION DIET

Consult the tables in the Cholesterol chapter and follow the advice given in Sections A, B, and C below. This will fulfill the recommendation of fat intake to be 30% of food energy. You will receive enough polyunsaturated fat and protein without having to do complicated calculations. The American Heart Association Prudent Diet gives similar recommendations.

These recommendations do not strictly apply if your blood cholesterol is less than 180 mg/dl, because you obviously deal with cholesterol by your own natural process. Foods with a high salt (sodium) content should be avoided or used sparingly (see Table 3).

A. Do Not Use the Following Foods

- Organ meats such as liver, kidney, sweetbreads, heart, or brain
- Meat fat, heavily marbled steaks, mutton, salt pork, or duck
- Whole milk or whole milk products, cream, lard, and non-vegetable margarine, or vegetable margarine that has saturated fats or palm oil
- Coconut oil or products containing coconut oil such as nondairy coffee cream substitutes, palm oil and peanut oil, or peanut butter

B. Use the Following Foods Sparingly and in Small Amounts

- Roast beef, luncheon meats, bacon, sausages, hamburger, and spare ribs
- Butter, egg yolk, cheese made from whole milk or cream, pies, chocolate pudding, whole milk pudding, and ice cream
- Lobster, which has a high cholesterol content and is often served with abundant butter
- Peanuts, cashews, and brazil nuts

C. Use the Following Recommended Foods

- All root vegetables; lentils, and split peas, which are rich in protein and fiber; fruits daily including avocado despite its very small saturated fat content. Do not “overindulge” in vegetables containing a high content of vitamin K such as broccoli, alfalfa, turnip greens, squash, and lettuce, because an increase in vitamin K intake may increase clot formation.
- Fish of all types, even when described as fatty fish, contain little saturated fat but have an abundance of omega-3 fatty acids that protect the arteries. Shrimp are not as bad as claimed, provided they are not fried in batter and are used only occasionally. Remember, any food fried in batter increases the saturated fat content.
- Poultry, chicken breast, and turkey, which, when cooked with the skin off, contain little saturated fat or cholesterol. You must cut fat from meat, including chicken, before cooking.
- Lean beef or veal.
- Fat and oils to be used include polyunsaturated vegetable oils with alpha-linolenic acid such as canola and soybean oil should be used for cooking, and polyunsaturated or olive oil margarine to be used as much as possible in place of butter. A margarine with added alpha-linolenic acid and without hydrogenation or added palm oil would be useful.
- Carbohydrates (sugars and starchy foods) such as bread or other flour products, potato, and rice to maintain normal body weight.
- Onions and garlic should be used, but use garlic powder, not garlic salt, which has a high sodium content (see Table 3).

- Alpha-linolenic acids found in walnuts and purslane are rich in alpha-linolenic acid and are strongly recommended.

Alpha-linolenic acid is a long-chain fatty acid, which is a significant component of the Cretan Mediterranean diet. Alpha-linolenic acid has an aspirin-like effect and reduces the stickiness of blood platelets and thus prevents clotting in arteries. A clinical study using an alpha-linolenic, acid-rich Mediterranean diet was reported in *Lancet*, June 1994. It is thought to be useful in decreasing recurrent heart attacks in patients following a first heart attack.

The Mediterranean type diet consists of root and green vegetables, more bread, fish, poultry, less beef, lamb, and pork and daily fruit, nuts, and olive oil. Butter was replaced by canola oil margarine with 5% alpha-linolenic acid added. The Mediterranean style diet is strongly recommended (see the chapters Dyslipidemia and Diets and Heart Disease).

The Cretans and Japanese have the lowest heart attack mortality in the world and have a high intake of alpha-linolenic acid. The source of alpha-linolenic acid for the Cretans included purslane and walnuts. Nuts that are also cardioprotective include almonds, walnuts, and hazelnuts.

BIBLIOGRAPHY

- Ambrose, J. A., D'Agate, D. J. et al. Plaque rupture and intracoronary thrombus in nonculprit vessels. *J. Am. Coll. Cardiol.*, 45:959–660, 2005.
- Andersen, H. R., Nielsen, T. T., Vesterlund, T., et al. Danish multicenter randomized study on fibrinolytic therapy versus acute coronary angioplasty in acute myocardial infarction: rationale and design of the DANish trial in Acute Myocardial Infarction-2 (DANAMI-2). *Am. Heart J.*, 146:234–241, 2003.
- Andersen, H. R. et al. A comparison of coronary angioplasty with fibrinolytic therapy in acute myocardial infarction. *N. Engl. J. Med.*, 349:733–742, 2003.
- Antoniucci, D., Rodriguez, A., Hempel, A. et al. A randomized trial comparing primary infarct artery stenting with or without abciximab in acute myocardial infarction. *J. Am. Coll. Cardiol.*, 42:1879–1885, 2003.
- ASSENT-3: Assessment of the Safety and Efficacy of a New Thrombolytic Regimen Investigators. Efficacy and safety of tenecteplase in combination with enoxaparin, abciximab, or unfractionated heparin: The ASSENT-3 randomised trial of acute myocardial infarction. *Lancet*, 358:605–613, 2001.
- Braunwald, E. Application of current guidelines to the management of unstable angina and non-ST-elevation myocardial infarction. *Circulation*, 108:III–28, 2003.
- Califf, R. M. Supplement on acute coronary syndromes: introduction. *Circulation*, 108:III–1, 2003.
- Califf, R. M., and Faxon, D. P. Need for centers to care for patients with acute coronary syndromes. *Circulation*, 107:1467–1470, 2003.
- CAPRICORN investigators: the effect of carvedilol on outcome after myocardial infarction in patients with left ventricular dysfunction. The CAPRICORN randomized trial. *Lancet*, 357:1385–1390, 2001.
- Chieffo, A., Stankovic, G., Bonizzoni, E. et al. Early and mid-term results of drug-eluting stent implantation in unprotected left main. *Circulation*, 111:791–795, 2005.
- COPERNICUS: Carvedilol prospective randomized cumulative survival study group; effect of carvedilol on survival in severe chronic heart failure. *N. Engl. J. Med.*, 344:1651–58, 2001.
- Corti, R., Fuster, V., and Badimon, J. J. Pathogenetic concepts of acute coronary syndromes. *J. Am. Coll. Cardiol.*, 41:7s–14s, 2003.
- Cowper, P. A., Udayakumar, K., Sketch, M. H., Peterson, E. D. et al. Economic effects of prolonged clopidogrel therapy after percutaneous coronary intervention. *JACC*, 45:369–376, 2005.
- CREDO Investigators: Steinhubl, S. E., Berger, B. P., Mann, J. T. et al. Esroy and sustained dual oral antiplatelet therapy following PCI: A randomized controlled trial. *JAMA*, 288:2411, 2002.
- Čulić, V., Eterović, D., Mirić, D. et al. Meta-analysis of possible external triggers of acute myocardial infarction. *Int. J. Cardiol.*, 99:1–8, 2005.
- Davies, M. J. Stability and instability: two faces of coronary atherosclerosis. The Paul Dudley White lecture 1995. *Circulation*, 94:2013–2020, 1996.
- de Winter, R. J., Windhausen, F., Cornel, J. H., et al. For the invasive versus conservative treatment in unstable coronary syndromes (ICTUS) investigators. Early invasive versus selectively invasive management for acute coronary syndromes. *N. Engl. J. Med.*, 353:1095–1104, 2005.
- Ellis, J. J., Eagle, K. A., Kline-Rogers, E. M. et al. Depressive symptoms and treatment after acute coronary syndrome. *Int. J. Cardiol.*, 99:443–447, 2005.
- Fibrinolytic Therapy and Trialist (FIT) Cooperative Group. Indications for fibrinolytic therapy in suspected acute myocardial infarction: Collaborative overview of early mortality and major mortality results from all randomized trials for more than 1000 patients. *Lancet*, 343:311, 1994.
- Fischer, M., Broeckel, U., Holmer, S. et al. Distinct heritable patterns of angiographic coronary artery disease in families with myocardial infarction. *Circulation*, 111:855–862, 2005.
- Giugliano, R. P., Braunwald, E. The year in non-ST-segment elevation acute coronary syndromes. *J. Am. Coll. Cardiol.*, 46: 906–919, 2005.
- Grines, C. L. Clinical debate: Primary angioplasty: the strategy of choice. *N. Engl. J. Med.*, 335:1313–1317, 1996.
- Grines, C. L., Browne, K. F., Marco, J., et al. A comparison of immediate angioplasty with thrombolytic therapy for acute myocardial infarction. *N. Engl. J. Med.*, 328:673, 1993.
- Grines, C. L., Serruys, P., and O' Neill, W. W. Fibrinolytic therapy: Is it a treatment of the past? *Circulation*, 107:2538–2542, 2003.
- Gross, G. J. et al. Sildenafil and endothelial dysfunction in humans. *Circulation*, 111:721–723, 2005.
- GISSI-2: Gruppo Italiano per lo Studio della Sopravvivenza Nell' Infarto Miocardico. A factorial randomised trial of alteplase versus SK and heparin versus no heparin among 12,490 patients with acute myocardial infarction. *Lancet*, 336:65, 1990.
- GISSI-3: Gruppo Italiano per lo Studio della Sopravvivenza nell' Infarto Miocardico. Effects of lisinopril and glyceryl trinitrate singly and together on 6-week mortality and ventricular function. *Lancet*, 343:1115, 1994.
- Gruppo Italiano per lo Studio della Streptochinasi Nell' Infarto Miocardico (GISSI). Effectiveness of intravenous thrombolytic treatment in acute myocardial infarction. *Lancet*, 1:397, 1986.
- Gurbel, P. A., Bliden, K. P., Zaman, K. A., Yoho, J. A., Hayes, K. M., Tantry, U. S. et al. Clopidogrel loading with eptifibatid to arrest the

- reactivity of platelets: Results of the clopidogrel loading with eptifibatid to arrest the reactivity of platelets (CLEAR PLATELETS) study. *Circulation*, 111:1153–1159, 2005.
- GUSTO Investigators. An international randomized trial comparing four thrombolytic strategies for acute myocardial infarction. *N. Engl. J. Med.*, 329:673, 1993.
- GUSTO Angiographic Investigators. The effects of tissue plasminogen activator, SK, or both on coronary-artery patency, ventricular function, and survival after acute myocardial infarction. *N. Engl. J. Med.*, 329:1615, 1993.
- Herrmann, H. C. et al. Transfer for primary angioplasty: The importance of time. *Circulation*, 111:718–720, 2005.
- ISIS-2 (Second international study of infarct survival) Collaborative Group. Randomised trial of intravenous streptokinase, oral aspirin, both, or neither among 17,187 cases of suspected acute myocardial infarction: ISIS-2. *Lancet*, 2:350, 1988.
- ISIS-3 (Third International Study of Infarct Survival) Collaborative Group. A randomised comparison of streptokinase vs. tissue plasminogen activator vs. anistreplase and of aspirin plus heparin vs. aspirin alone among 41,299 cases of suspected acute myocardial infarction. *Lancet*, 339:953, 1992.
- ISIS-4 (Fourth International Study of Infarct Survival) Collaborative Group. A randomised factorial trial assessing early oral captopril, oral mononitrate, and intravenous magnesium sulphate in 58,050 patients with suspected acute myocardial infarction. *Lancet*, 345:669, 1995.
- Jacobs, A. K. Primary angioplasty for acute myocardial infarction. Is it worth the wait? *N. Engl. J. Med.*, 349:798, 2003.
- Kastrati, A., Mehilli, J., Schlotterbeck, K. et al. for BRAVE Investigators. Late-breaking clinical trial abstracts. A randomized evaluation of early administration of reteplase plus abciximab or abciximab alone prior to percutaneous coronary intervention in patients with acute myocardial infarction. *Circulation*, 108:2723, 2003.
- Keeley, E. C., Boura, J. A., and Grines, C. L. Comparison of primary angioplasty and intravenous thrombolytic therapy for acute myocardial infarction: A quantitative review of 23 randomised trials. *Lancet*, 361:13–20, 2003.
- Keeley, E. C., Boura, J. A., and Grines, C. L. Primary angioplasty versus intravenous thrombolytic therapy for acute myocardial infarction: A quantitative review of 23 randomized trials. *Lancet*, 361:13–20, 2003.
- Kereiakes, D. J. Adjunctive pharmacotherapy prior to percutaneous coronary intervention in non-ST-elevation acute coronary syndromes: The role of modulating inflammation. *Circulation*, 108 (Suppl.):III-22–III-27, 2003.
- Khan, M. Gabriel Management of acute myocardial infarction. *Cardiac Drug Therapy*, W. B. Saunders, Philadelphia, 2003.
- Kloner, R. A. et al. The “Merry Christmas Coronary” and “Happy New Year Heart Attack” phenomenon. *Circulation*, 110:3744–3745, 2004.
- Lange, R. A. and Hillis, L. D. Antiplatelet therapy for ischemic heart disease. *N. Engl. J. Med.*, 350:277–280, 2004.
- Lange, R. A., and Hillis, L. D. Immediate angioplasty for acute myocardial infarction. *N. Engl. J. Med.*, 328:726, 1993.
- LATE Study Group. Late assessment of thrombolytic efficacy study with alteplase 6–24 hours after onset of acute myocardial infarction. *Lancet*, 342:759, 1993.
- Lopez-Sendon, W., Remme, J., Sharpe, W, Ford, D. N. I. et al. *J. Am. Coll. Cardiol.*, 45:4525–30.
- Machecourt, J., Bonnefoy, E., Vanzetto, G. et al. Primary angioplasty is cost-minimizing compared with pre-hospital thrombolysis for patients within 60 minutes of a percutaneous coronary intervention center. *J. Am. Coll. Cardiol.*, 45:515–524, 2005.
- Maehara, A., Mintz, G. S., Bui, A. B. et al. The morphologic and angiographic features of coronary plaque rupture detected by intravascular ultrasound. *J. Am. Coll. Cardiol.*, 40:904–910, 2002.
- McMurray, J., Kober, L., Robertson, M. et al. Antiarrhythmic effect of carvedilol after acute myocardial infarction: Results of the carvedilol post-infarct survival control in left ventricular dysfunction (CAPRICORN) trial. *J. Am. Coll. Cardiol.*, 45:525–530, 2005.
- McSweeney, J. C., Cody, M., O’Sullivan, P. et al. Women’s early warning symptoms of acute myocardial infarction. *Circulation*, 108: 2619–2623, 2003.
- McSweeney, J. C., Cody, M., O’Sullivan, P. et al. Women’s Early Warning Symptoms of Acute Myocardial Infarction, *Circulation*, 2003.
- Monaco, C., Mathur, A., Martin, J. F. et al. What causes acute coronary syndromes? Applying Koch’s postulates [Review]. *Atherosclerosis*, Vol. 179, Issue 1, 1–15, 2005.
- Oei, H. H. S., van der Meer, I. M., Hofman, A. et al. Lipoprotein-associated phospholipase A2 activity is associated with risk of coronary heart disease and ischemic stroke: The Rotterdam study. *Circulation*, 111:570–575, 2005.
- Park, S. J., Kim, Y. H., Lee, B. K. et al. Sirolimus-eluting stent implantation for unprotected left main coronary artery stenosis: Comparison with bare metal stent implantation. *J. Am. Coll. Cardiol.*, 45:351–6, 2005.
- Petersen, S., Peto, V., and Rayner, M. In *Coronary Heart Disease Statistics*. London: British Heart Foundation, 2004.
- Phillips, D. P., Jarvinen, J. R., Abramson, I. S. et al. Cardiac mortality is higher around Christmas and New Year’s than at any other time: The holidays as a risk factor for death. *Circulation*, 110:3744–3745, 2004.
- Pitt, B., Reichek, N., Willenbrock, R. et al. Effects of eplerenone, enalapril, and eplerenone/enalapril in patients with essential hypertension and left ventricular hypertrophy (EPHESUS). The 4E-left ventricular hypertrophy study. *Circulation*, 108:1831, 2003.
- Pitt, B., White, H., Nicolau, J., et al. For the EPHESUS investigators eplerenone reduces mortality 30 days after randomization following acute myocardial infarction in patients with left ventricular systolic dysfunction and heart failure. *J. Am. Coll. Cardiol.*, 46: 425–431, 2005.
- Rigatelli, G. et al. Normal angiogram in patients with acute coronary syndrome: Searching for unusual substrates of myocardial ischemia. *Int. J. Cardiol.*, 99:25–27, 2005.
- Rittersma, S. Z. H., van der Wal, A. C., Koch, K. T. et al. Plaque instability frequently occurs days or weeks before occlusive coronary thrombosis: A pathological thrombectomy study in primary percutaneous coronary intervention. *Circulation*, 111:1160, 2005.
- Ruidavets, J. B., Cournot, M., Cassadou, S., Giroux, M., Meybeck, M., Ferrières, J. et al. Ozone air pollution is associated with acute myocardial infarction. *Circulation*, 111:563–569, 2005.
- Sabatine, M. S., Cannon, C. P., Gibson, C. M. et al. For the CLARITY-TIMI 28 Investigators. Addition of clopidogrel to aspirin and fibrinolytic therapy for myocardial infarction with ST-segment elevation. *N. Engl. J. Med.*, 352:1179–1189, 2005.
- Saia, F., Lemos, P. A., Lee, C. H. et al. Sirolimus-eluting stent implantation in st-elevation acute myocardial infarction. *Circulation*, 108:1927, 2003.
- Schulman, S. P. et al. Antiplatelet therapy in non-ST-segment elevation acute coronary syndromes. *JAMA*, 292:1875–1882, 2004.
- Shah, P. K. Mechanisms of plaque vulnerability and rupture. *J. Am. Coll. Cardiol.*, 41:15s–22s, 2003.
- Spertus, J. A., Nerella, R., Kettlekamp, R. et al. Risk of restenosis and health status outcomes for patients undergoing percutaneous coronary intervention versus coronary artery bypass graft. *Circulation*, 111:768–773, 2005.

- Takano, M., Inami, S., Ishibashi, F. et al. Angioscopic follow-up study of coronary ruptured plaques in nonculprit lesions. *J. Am. Coll. Cardiol.*, 45:652–658, 2005.
- TAXUS: Stone, G. W., Ellis, S. G., Cox, D. A. et al. for TAXUS-IV Investigators. A polymer-based, paclitaxel-eluting stent in patients with coronary artery disease. *N. Engl. J. Med.*, 350:221–231, 2004.
- Topol, E. J., and Kereiakes, D. J. Regionalization of care for acute ischemic heart disease: A call for specialized centers. *Circulation*, 107:1463–1466, 2003.
- Valgimigli, M., Ceconi, C., Malagutti, P. et al. Tumor necrosis factor- α receptor 1 is a major predictor of mortality and new-onset heart failure in patients with acute myocardial infarction: The cytokine-activation and long-term prognosis in myocardial infarction (C-ALPHA) study. *Circulation*, 111:863–870, 2005.
- van der Hoeven, B. L., Pires, N. M. M., Warda, H. M. et al. Drug-eluting stents: Results, promises and problems. *Int. J. Cardiol.*, 99:9–17, 2005.
- Varnava, A. M., Mills, P. G., and Davies, M. J. Relationship between coronary artery remodeling and plaque vulnerability. *Circulation*, 105:393–343, 2002.
- Vasan, R. S., D'Agostino, Sr., R. B. et al. Age and time need not and should not be eliminated from the coronary risk prediction models. *Circulation*, 111:542–545, 2005.
- Vetrovec, G. W. et al. Optimizing percutaneous coronary intervention outcomes: The next steps. *Circulation*, 111:125–126, 2005.
- Wang, K., Asinger, R. W., and Marriott, H. J. L. ST elevation in conditions other than acute myocardial infarction. *N. Engl. J. Med.*, 349:2128–2135, 2003.
- Wong, G. C., Giugliano, R. P., and Antman, E. M. Use of low-molecular-weight heparins in the management of acute coronary artery syndromes and percutaneous coronary intervention. *JAMA*, 289:331–342, 2003.
- Windecker, S., Remondino, A., Eberli, F. R., et al. Sirolimus-eluting and paclitaxel-eluting stents for coronary revascularization. *N. Engl. J. Med.*, 353: 653–662, 2005.
- Yamaji, H., Iwaki, K., Kusachi, S. et al. Prediction of acute left main coronary artery obstruction by 12-lead electrocardiography; ST-segment elevation in AVR with less ST-segment elevation in lead V1. *J. Am. Coll. Cardiol.*, 38:1348, 2001.
- Yusuf, S., Hawken, S., Ôunpuu, S., On behalf of the INTERHEART Study Investigators et al. Effect of potentially modifiable risk factors associated with myocardial infarction in 52 countries (the INTERHEART study): Case-control study. *Lancet*, 364:937–52, 2004.

Heart Failure

- I. Incidence and Pathogenesis
- II. Basic Causes of Heart Failure
- III. Precipitating Factors
- IV. Pathophysiology
- V. Symptoms and Signs
- VI. Diagnosis
- VII. Drug Treatment
- VIII. Nondrug Therapy
- IX. What to Expect in the Hospital and on Discharge

GLOSSARY

cardiomyopathy heart muscle disease.

ejection fraction the fraction of blood ejected from the heart into the arteries, normally this ranges from 50 to 75%; a low ejection fraction is less than 45%; often used as a marker of ventricular contractility.

inotropic an effect that affects the force of muscular contractions; negative inotropic refers to decreased myocardial contractility that may lead to poor pumping of blood, reduced ejection fraction, and heart failure.

myocardial infarction death of an area of heart muscle due to blockage of a coronary artery by blood clot and atheroma; medical term for heart attack or coronary thrombosis.

THE WORLD FACES AN EPIDEMIC OF HEART failure. This condition, unlike coronary artery disease, has no territorial boundaries (see Tables 1 and 2 in the chapter Angina for worldwide statistics). Heart failure is common both in developed and developing countries. In the United States more Medicare dollars are spent on the management of heart failure than for any other diagnosis. The cost worldwide is astronomic.

I. INCIDENCE AND PATHOGENESIS

Heart failure is present when the heart is unable to eject enough blood from its chambers into the circulation to

satisfy the needs of the body. Heart failure is responsible for over one million admissions to hospitals in the United States.

Heart failure is usually the result of a diseased heart. The most common cause is a very weak heart muscle. The heart muscle is the strongest muscle in the body. During an average life span, the heart beats about 2.5 billion times, pumping more than 227 million liters of blood. If this work could be accomplished in one moment, it would be sufficient to lift a weight of about 400 million pounds off the ground. If the heart muscle is severely weakened and unable to adequately expel the blood brought to the left or right ventricle, blood backs up in the veins that drain into the left or right side of the heart.

Oxygenated blood flows from the lungs through veins to the left atrium and left ventricle (see Fig. 1). These veins in the lungs can become overdistended with blood and leak fluid (sodium and water) into the lung tissue. This is called lung edema due to left heart failure. If heart failure continues for several days, the fluid may also accumulate in the space between the lungs and the chest wall. This is called pleural effusion (water on the lungs).

The lung is like a sponge and normally the spaces (air sacs or alveoli) are dry and full of air. In heart failure, the excess fluid is in the spaces as well as in the spongework of the lungs. This makes the lungs heavier and the fluid makes them stiffer with less capacity to distend with each breath; therefore, the individual gets short of breath. With heart failure breathing is quicker and less deep than normal breathing. The fluid in the air sacs and spongework of the lungs consists of water, sodium, and some red blood cells. The patient may cough up sputum, which is sometimes blood-tinged. An individual with this type of condition is said to be in left heart failure or simply heart failure, because there is overdistension (congestion) of blood vessels and excess fluid in the spongework of the lungs. This condition is also called congestive heart failure, but heart failure is the preferred term because heart failure may occur without significant congestion in the lungs.

In heart failure, blood and fluid overdistend or congest the veins that bring blood into the failing muscular

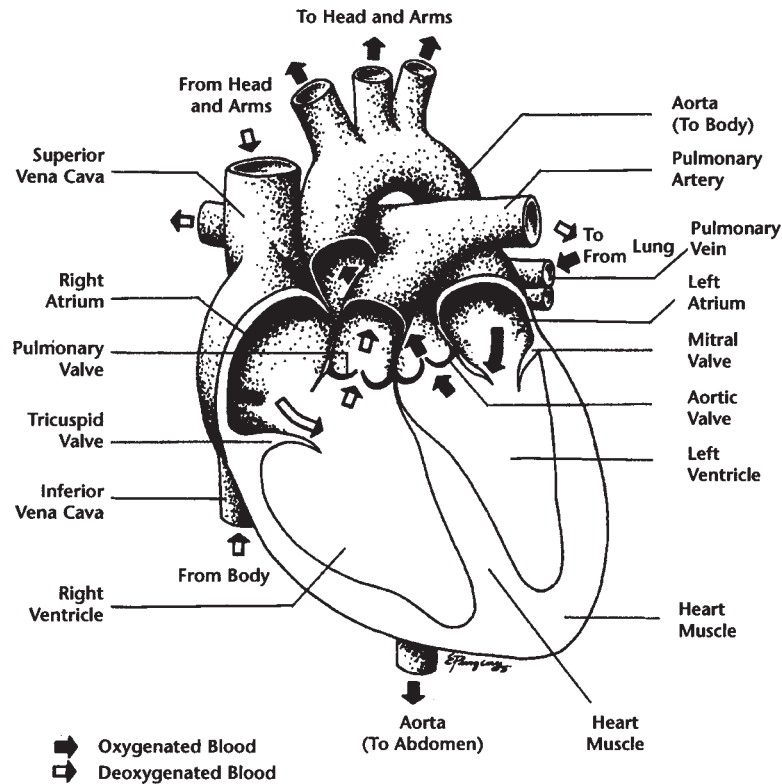

FIGURE I Structure of the heart and circulation of blood.

chambers. This congestion or visible distension of veins is seen in the lung on a chest x-ray.

In right heart failure, the distension and congestion occur in the veins of the neck, arms, liver, and legs. During the assessment for the presence of heart failure the examining doctor looks for these distended veins (jugular veins) at the side of the neck which take blood from the head and neck into the right side of the heart. When a normal individual stands, sits, or is propped up with the back and head elevated about 45 degrees, these neck veins are not visibly distended. In normal individuals they become distended temporarily when there is a marked increase in intrathoracic pressure like during singing, trumpet playing, and coughing spells. If these veins are distended and associated with shortness of breath, the physician can be fairly certain that heart failure is present.

What about nonvisible veins in the body? Distension backs up in veins within the liver, which enlarges, and in some cases fluid may accumulate in the abdominal cavity (ascites). The veins of the legs may not be visibly distended but the blood is under backpressure and fluid leaks out into tissues, especially when the individual stands, walks, or sits for long periods. The swelling usually occurs more frequently at the end of the day, improves after a few hours in bed, and is best in the morning.

The fluid around the ankles and feet is called edema and is a hallmark of heart failure, although it can occur with obstruction of the veins from other causes. This fluid is similar to that described in the lungs, consisting of water and sodium; therefore, the legs are brine-logged not just waterlogged. The swelling usually occurs in both legs whereas in obstruction of veins it is one-sided. The accumulation of several gallons of fluid may result in very extensive involvement of the entire legs, thighs, abdomen (ascites), and lungs (pleural effusion).

II. BASIC CAUSES OF HEART FAILURE

A. Coronary Artery Disease

In developed countries coronary artery disease causing myocardial infarctions (heart attacks) is responsible for more than 40% of cases of heart failure. Left heart failure is most often due to extensive damage to the muscle of the left ventricle like the damage that occurs during one or more heart attacks (see the chapter Heart Attacks). Patients recover within a few days as the muscle is able to function well enough in the majority of those with the disease. In about 30 in every 100 patients with acute myocardial

infarction, heart failure persists to a mild to moderate degree and medications are necessary. With the occurrence of a second heart attack further damage to the muscle occurs, which leads to very poor heart function and heart failure. Such patients should not feel that it is the end of the line; many can live for several years provided that there is adequate medical treatment. Surgery is not usually indicated unless the muscle balloons to form what is called an aneurysm. Fortunately this is rare and only occurs in about 1 in 10,000 patients. If the aneurysm can be removed, a reasonable cure is possible with major surgery.

B. Hypertension

The heart muscle is weakened over several years by high blood pressure. The left ventricle has more work to do to pump millions of liters of blood against greater resistance through tight, constricted arteries. The additional work causes the muscle of the left ventricle to increase in size much like the increased biceps of a blacksmith or weight-lifter. Heart enlargement (cardiomegaly) is easily seen on a chest x-ray. After several years, the muscle is strained and the patient may suddenly be stricken by an episode of severe shortness of breath due to failure of the muscle and a backup of fluid in the lungs. Incidentally, heart failure appears to be precipitated in blacks much more quickly than in whites at lower levels of blood pressure.

Hypertension and hypertensive heart disease are responsible for more than 40% of patients with heart failure. More than 60% of individuals over age 65 in North America have hypertension and this increases the occurrence of heart failure. The incidence is higher in African-Americans. The prevalence of hypertension in the developing countries in general is similar to that in the white population of the United States. (See chapter entitled Hypertension.)

C. Valvular Heart Disease

The mitral and aortic valves are depicted in Fig. 1. Diseases of the heart valves, for example, the aortic valve, can impede the free flow of blood from the left ventricle into the aorta — aortic stenosis. When the mitral valve between the left atrium and left ventricle is tight and obstructing the flow of blood (mitral stenosis), blood backs up in the lungs and a cough with severe shortness of breath can occur.

Diseases of the mitral and aortic valves causing mitral stenosis, mitral regurgitation, aortic stenosis, and aortic regurgitation all lead to heart failure if they are not

adequately managed medically and finally by surgical correction (see the chapter Valve Diseases). Valvular heart disease accounts for approximately 15% of all cases of heart failure in developed countries and for more than 30% of heart failure cases in developing countries.

D. Cardiomyopathy

Heart muscle diseases (cardiomyopathy) not due to atherosclerosis of the coronary arteries or valvular disease are fortunately rare. In rare cases cardiomyopathy can be caused by alcohol abuse. Viruses that cause a very mild or moderate flu-like illness can cause microscopic scars in the heart muscle (myocarditis) and weaken the muscle sufficiently to cause heart failure (see the chapter Cardiomyopathy).

E. Right Heart Failure

High blood pressure may be limited to the arteries in the lungs (pulmonary arteries) where the blood from the right ventricle is ejected. This situation is called pulmonary hypertension and it can occur in patients with severe emphysema. With emphysema many lung vessels are destroyed, thus increasing the resistance and blood pressure in the lung circulation. This condition also occurs as idiopathic pulmonary hypertension. Disease of the pulmonary valves and pulmonary hypertension cause the right ventricle to enlarge and it finally fails causing right heart failure. (See chapter entitled Pulmonary Arterial Hypertension.)

III. PRECIPITATING FACTORS

In addition to problems in the heart and with high blood pressure, there are several factors that precipitate heart failure when the muscle is weakened. These conditions must be avoided or treated. Problems that can precipitate heart failure in patients with a weak heart muscle or diseased valve include the patient–physician problems listed below.

- Reduction or discontinuation of digoxin or diuretics; the doctor may reduce or discontinue digoxin or diuretics or the patient may stop taking the medications
- The patient may increase the intake of foods containing excess salt
- Increased physical exertion
- Obesity

Other problems such as increased cardiac work imposed on the heart are precipitated by those listed below.

- A marked increase in blood pressure
- Abnormal heart rhythms; e.g., atrial fibrillation
- Pulmonary embolism (blood clot in the lung)
- Infection; e.g., pneumonia, chest, urinary, or others
- Thyrotoxicosis (overactive thyroid) or severe hypothyroidism

Progression or complications of the basic underlying heart disease include acute heart attack, several heart attacks, or aneurysm formation. Valvular heart disease causing increased stenosis or regurgitation should also be included.

Drugs that weaken heart muscle contraction and may precipitate heart failure are shown in the following list.

- Beta-blockers in large doses precipitate heart failure but smaller doses of carvedilol, metoprolol, and bisoprolol have been shown to prevent heart failure and reduce mortality and hospitalizations for heart failure
- Corticosteroids (cortisone, prednisone)
- Disopyramide
- Calcium antagonists such as verapamil and diltiazem
- Stimulant drugs that increase blood pressure, e.g., adrenaline, amphetamine derivatives, and some cough and cold remedies
- Alcohol, acute excess (four to eight ounces of gin in a period of less than two hours causes depression of cardiac contractility)

Antiarthritic (nonsteroidal anti-inflammatory) agents including indomethacin, ibuprofen, and piroxicam; the newer selective nonsteroidal anti-inflammatory agents (COX-2 inhibitors) such as celecoxib, meloxicam, and rofecoxib retain salt and water in the body and commonly precipitate heart failure in patients with poor heart muscle function. (See chapter entitled Nonsteroidal Anti-Inflammatory Agents.)

IV. PATHOPHYSIOLOGY

A. Nature's Defense Mechanisms

When heart failure is caused by any of the diseases or precipitating factors outlined above, the body's defenses are called upon to assist. Nature always has a way to compensate. Heart failure causes less blood to be ejected from the ventricles. Instead of about 5 liters per minute ejected at rest, the cardiac output can fall to less than 2 liters and not meet the needs of the body.

One compensatory response involves the nervous system and adrenal glands. They are stimulated to produce

adrenaline and noradrenaline. Adrenaline constricts arteries and, therefore, increases the resistance in the arteries, which increases blood pressure to allow survival. This increase in resistance is a great load that can be likened to a steep hill against which the left ventricle must pump. The muscle is already very weak, and the increased workload increases heart failure. Imagine a poorly tuned 1934 car trying to climb a long, steep hill. Nature's compensatory responses are usually useful to the body, but in this case, they are counterproductive. The only way the heart muscle can do the work is to increase the contraction of the muscle and to reduce the resistance in the arteries. Nature unfortunately does not have a built-in answer and increases the resistance in arteries in order to increase blood pressure. The body is programmed to increase blood pressure when the cardiac output and blood pressure fall for any reason. Fortunately, medical scientists, by unraveling these mechanisms, were able to produce a series of drugs in the early 1980s that reduce this resistance. These drugs are called vasodilators (see Section VII).

Another compensatory mechanism involves neurohormonal activation. This occurs when two enzymes, renin and angiotensin, are activated. Angiotensin causes severe constriction of arteries and increases blood pressure. Renin stimulates the adrenal glands to secrete a hormone, aldosterone, which causes sodium and water to return to the blood vessels with the hope that blood supply and blood pressure will increase. The increased sodium and water returned to the blood by the kidney further increases leg and lung edema. Therefore, the body is once more deceived.

The kidneys react immediately and utilize special defense mechanisms that cause a considerable amount of sodium and water to be returned to the blood vessels. The extra sodium and water again leak out of the blood vessels into the lungs and legs, which cause congestion and shortness of breath increase. Diuretics, which cause the kidneys to excrete the excess salt and water, relieve shortness of breath and leg swelling.

As mentioned earlier, adrenaline is secreted during heart failure and causes blood pressure to increase and the heart muscle to pump more forcefully. This compensatory response is helpful and in some cases bed rest and oxygen with this normal response may cause some relief. Drugs, such as adrenaline, which increase the force of contraction of the heart muscle, are called inotropic drugs but the majority of these inotropic agents, for example, dobutamine, amrinone, and others have serious adverse effects and rarely used.

The best known example of an inotropic drug is digitalis, which has been used for the past 200 years for the treatment of heart failure.

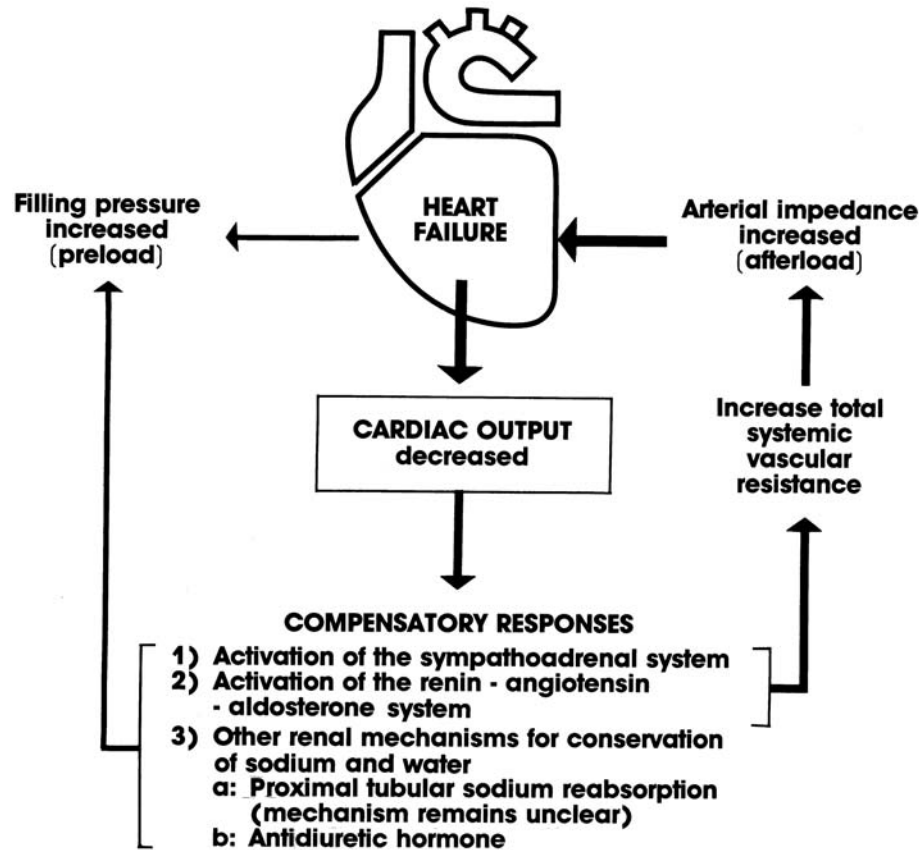

FIGURE 2 Pathophysiology of heart failure. (From Khan, M. Gabriel (2003). *Cardiac Drug Therapy*, 6th ed., Philadelphia: W.B. Saunders.)

You will note that the central result of heart failure is a low cardiac output, which triggers the compensatory responses mentioned. Nature increases the blood pressure and heart rate but fails to increase the cardiac output adequately. It is blood pressure that is vital for existence. No blood pressure means no circulation to the brain and coronary arteries and, therefore, death. Researchers have failed to produce drugs that could increase the cardiac output when given orally without producing serious side effects.

B. Relevant Definitions

Cardiac output = stroke volume \times the heart rate

Stroke volume is a reflection of preload (filling pressure), myocardial contractility, and afterload (arterial impedance; see Fig. 1 in the chapter Exercise and the Heart).

Left ventricular work and myocardial oxygen consumption depend on:

heart rate \times blood pressure (rate pressure product)

blood pressure = cardiac output \times systemic vascular resistance

Compensatory adjustments are initiated by sympathetic stimulation that causes an increase the heart rate, force of myocardial contraction, and systemic vascular resistance. The activation of the renin-angiotensin-aldosterone system causes intense constriction of arterioles and arteries and, therefore, increases systemic vascular resistance and blood pressure. An increase in aldosterone produces sodium and water retention in the distal nephron (see Fig. 1 in the chapter Diuretics).

V. SYMPTOMS AND SIGNS

A. Symptoms

Shortness of breath (dyspnea) at rest and on minimal exertion, paroxysmal nocturnal dyspnea (awakened from sleep because of shortness of breath), weakness, fatigue, edema of both legs, and an increase in abdominal girth are common complaints of heart failure. Minor physical activities are hindered because of bothersome shortness of breath.

I. New York Heart Association Functional Class

This functional class is often used as a reference in publications and in medical reports.

- Class I: asymptomatic on ordinary physical activity associated with maximal oxygen consumption (VO₂) is greater than 20 ml/kg/minute
- Class II: asymptomatic on ordinary physical activity with maximum oxygen consumption of 16–20 ml/kg/minute
- Class III: asymptomatic on less than ordinary physical activity with maximum oxygen consumption of 10–15 ml/kg/minute
- Class IV: symptomatic at rest or on any activity with maximum oxygen consumption of less than 10 ml/kg/minute

B. Physical Signs

Physical signs of heart failure on examination of the patient include the following list.

- There is an increase in jugular venous pressure greater than 2 cm above the sternal angle. This is a sign of right and left ventricular failure. In some patients the venous pressure may be normal if the left ventricular failure is mild. The most common cause of right ventricular failure is left-sided heart failure. On auscultation a third heart sound or a combination of the third and fourth sound summation gallop is heard. Crackles (crepitations) are heard on auscultation over the lower lung fields; if left ventricular failure is severe and pulmonary edema is present crepitations may be heard over most of the chest.
- Bilateral leg edema is characteristic of the left and right heart failure. In patients with severe heart failure edema may involve the legs and the lower back, sacral edema is seen in patients confined to bed.

VI. DIAGNOSIS

A. Chest X-Ray

A simple chest x-ray is the most important confirmatory test for the diagnosis of heart failure and reveals the following patterns.

- Interstitial pulmonary edema (signs of accumulation of excessive blood and fluid components of the blood in the spongework of the lung), pulmonary clouding, perihilar haze, and Kerley B or A lines caused by edema and thickening of interlobular septa

- Frank pulmonary edema (fluid within the alveoli and air sacs), alveolar pulmonary edema which causes a butterfly pattern that is occasionally unilateral
- Pleural effusions, the right usually greater than on the left
- Constriction of blood vessels in the lower lobe of the lung with dilatation of vessels in the upper lobes of the lung, a manifestation of pulmonary venous hypertension that is an early sign of left ventricular failure

B. B-Type Natriuretic Peptide

B-type natriuretic peptide is released from the cardiac ventricles in response to the increased wall tension that occurs in heart failure. Used in conjunction with the history, physical findings on examination, and a chest x-ray, the rapid measurement of B-type natriuretic peptide is useful in establishing or excluding the diagnosis of heart failure in patients with acute shortness of breath (see the chapter B-Type Natriuretic Peptide).

C. Echocardiogram

The echocardiogram is the most useful test for the further evaluation of patients with heart failure proven by clinical findings, chest x-ray, and when needed, B-type natriuretic factor. Table 1 indicates the usefulness of echocardiography.

VII. DRUG TREATMENT

A. Digitalis (Digoxin)

In 1775, William Withering, a Birmingham physician, learned of a midwife whose herbal brew had cured several people suffering from severe swelling of the legs and shortness of breath. The condition at that time was called dropsy. Withering studied the brew and concluded that the only active constituent of the 20 or more herbs was derived from the foxglove plant (*Digitalis purpurea*). He used the herb with a fair amount of success.

Digitalis has since been used extensively across the world to treat millions of people with heart failure. It causes the heart muscle to contract more forcefully which increases the flow of blood to the kidneys. Congestion, shortness of breath, and edema improve. This drug also slows the heart rate and causes the heart muscle to use oxygen more efficiently. In some individuals, heart failure is precipitated by a very irregular heart rhythm called atrial fibrillation,

TABLE I

Echocardiography, the Most Useful Test to Evaluate Patients with Proven Heart Failure

1. Assess left ventricular (LV) function, provides a sufficiently accurate ejection fraction (EF)^a for guidance of therapy
2. Screen for regional or global hypokinesis
3. Gives accurate cardiac dimensions; replaces radiology for cardiac chamber dilation
4. Assess regional LV wall motion abnormalities that indicate ischemia and significant coronary heart disease
5. Assess hypertrophy: concentric or other
6. Left atrial enlargement common with valvular heart disease and an early sign of left ventricular hypertrophy
7. Assess valvular heart disease
8. Congenital heart disease
9. Diastolic dysfunction, assess after known normal systolic function and no valvular disease
10. Pericardial disease, effusion, tamponade
11. Myocardial disease
12. Left atrial myxoma

^aNuclear imaging is more accurate for EF in absence of atrial fibrillation but does not assess valves, hypertrophy, or items 3 to 11, cost of two tests not justifiable.

From Khan, M. Gabriel (2003). *Cardiac Drug Therapy, sixth edition*, Philadelphia; W. B. Saunders, p. 260.

and heart rate may increase to 120–200 beats per minute. In such patients, digitalis is very successful in reducing the heart rate to 60–90 beats per minute and causes complete clearing of heart failure. Digitalis remains the only available oral drug to treat heart failure caused by atrial fibrillation, and today this is its main indication.

Digitalis is not used in all cases of heart failure where the heart rhythm is normal, because in some of these, a diuretic and an ACE inhibitor bring relief. Digitalis is available under various names. The most known and generally used preparation is digoxin. Digoxin is the purest preparation of digitalis and gives reliable blood levels. Thus, we will confine most of the remarks to this preparation. Other preparations have very minor differences in absorption from the gut, blood levels, and duration of action. Digoxin is marketed under different brand names and Lanoxin is the most common.

Supplied: Tablets: 0.125 mg, 0.25 mg.

Dosage: For maintenance, 0.25 mg daily usually at bedtime. In patients over age 70, 0.125 mg daily is usually sufficient. A lower dose of digoxin is now used compared with the dose advised in the previous 50 years. A serum digoxin level 0.5–0.8 ng/ml is adequate for beneficial effects in the management of heart failure. Patients on a low dose with the serum level indicated above have been shown to be less likely to experience worsening

heart failure and both their ejection fractions and treadmill exercise times were significantly higher than patients taking higher doses.

As outlined earlier, digoxin causes an increase in the force of contraction of the heart muscle and slows the heart rate, especially in patients who have atrial fibrillation. It is excreted virtually unchanged by the kidney. Therefore, in kidney dysfunction or failure, the drug accumulates and can reach toxic levels in the body. Patients with poor kidney function may therefore require 0.125 mg daily or every other day.

I. Advice and Adverse Effects

Kidney dysfunction or failure is the most common cause for toxicity. Note that individuals over age 70 may have kidney blood tests (for creatinine) that are recorded as normal when the kidney function is abnormal. The doctor therefore has to titrate the dose carefully in the elderly to avoid toxicity.

Nausea and vomiting are common symptoms of excess digoxin in the blood. Blue-green-yellow vision may occur but reverts to normal as soon as the drug is stopped. A very slow heart rate, less than 48 beats per minute, with extra heartbeats and the precipitation of abnormal heart rhythms are also seen with toxic doses. If this occurs, the drug must be discontinued and levels in the blood measured. Low blood potassium increases all adverse effects, and this may occur even with a small dose of digoxin. The potassium level in the blood should be checked every four months or more frequently in some cases. Diuretics are well known to cause potassium loss, and because they are virtually always used along with digoxin to treat heart failure, digoxin toxicity may occur. This results in serious heart rhythm disturbances. Your physician will give advice on your diet and tablets or if a liquid containing potassium is required. Digoxin toxicity was common during the 1970s.

It must be emphasized that experts who have used this drug for over 20 years in patients with moderate to severe heart failure due to poor left ventricular function recognize clearly that when the drug is discontinued or the dose reduced, heart failure often recurs. Toxicity does not occur if the patient and a careful physician cooperate to prevent this.

B. Digitoxin

Supplied: Tablets: 0.1 mg, 0.15 mg, and 0.2 mg.

Dosage: Initial and maintenance doses are the same: 0.05–0.1 mg daily; maximum 0.15 mg daily.

Digitoxin has a prolonged action and the effects can last four to six days. It is broken down in the liver and

excreted in the gut. Omission of a dose or kidney failure has little effect on serum levels. Levels are not usually increased in patients with severe liver dysfunction. The main “disadvantage” is that when digitoxin toxicity occurs, it can persist for several days.

C. ACE Inhibitors and Angiotensin Receptor Blockers

The angiotensin-converting enzyme (ACE) inhibitors and angiotensin receptor blockers (ARBs) are very useful in the management of all grades of heart failure and represent a major medical breakthrough. They are considered vasodilators and have been shown to save lives and prevent hospitalizations (see Table 2).

TABLE 2

ACE Inhibitors and angiotensin II Receptor Blockers (The Drug Index gives the generic drug name in lowercase; the pharmaceutical trade names begin with a capital letter. C = Canada when different from US; F = France, G = Germany)

USA	UK	EUROPE	JAPAN
ACE inhibitors			
benazepril		benazepril	benazepril
Lotensin		Briem (F) Cibace Cibacin Lotensine	
captopril	captopril	captopril	captopril
Capoten	Capoten	Captolane (F) Lopril (F) Lopirin (G) Tensobon (G)	Captopril
cilazapril	cilazapril	cilazapril	cilazapril
Inhibace	Vasace	Dynorm (G)	
enalapril	enalapril	enalapril	enalapril
Vasotec	Innovace	Pres (G) Renitec (F) Xanef (G)	Renivace
fosinopril	fosinopril	fosinopril	fosinopril
Monopril	Staril	Dynacil (G) Eliten (I)	
lisinopril	lisinopril	lisinopril	lisinopril
Prinivil	Carace	Longes	
Zestril	Zestril	Zestril (F)	

(Continued)

TABLE 2

Continued

USA	UK	EUROPE	JAPAN
moexipril	moexipril	moexipril	
Univasc	Perdix		
perindopril	perindopril	perindopril	perindopril
Aceon	Coversyl	Acertil Coversum Pexum	
quinapril	quinapril	quinapril	quinapril
Accupril	Accupro	Accuprin Acuitel Korec (F)	
ramipril	ramipril	ramipril	ramipril
Altace	Tritace	Delix Ramace Triatec (F) spirapril Renpress Sandopril	spirapril
trandolapril	trandolapril	trandolapril	trandolapril
Mavik	Gopten Odrick	Gopten	
		zefenopril	zefenopril
Angiotensin II receptor blockers			
candesartan	candesartan		candesartan
Atacand	Amias		
eprosartan	eprosartan		
Teveten			
irbesartan	irbesartan		
Avapro	Aprovel		
losartan	losartan	losartan	losartan
Cozaar	Cozaar	Cozaar	
olmesartan	olmesartan	olmesartan	
Benicar			
telmisartan	telmisartan	telmisartan	telmisartan
Micardis			
valsartan	valsartan	valsartan	valsartan
Diovan	Diovan	Diovan	

From Khan, M. Gabriel (2003). *Cardiac Drug Therapy, sixth ed.*, Philadelphia; W. B. Saunders, p. 517–518.

I. Actions of Captopril, Enalapril, Lisinopril, and Other ACE Inhibitors

As outlined earlier, during heart failure the body tries to maintain blood pressure at all costs in order to satisfy the needs of the brain and organs. If the blood pressure falls or the volume of blood reaching the kidneys falls, as occurs during bleeding or heart failure, the renin-angiotensin enzyme system is activated and angiotensin is produced. Angiotensin is a powerful constrictor of arteries and increases blood pressure, but this increases the work of the heart and worsens heart failure. Captopril and enalapril block a “converting enzyme” that converts angiotensin to its active component. This new group of vasodilators are therefore called angiotensin-converting enzyme (ACE) inhibitors. These drugs cause dilatation of the arteries, which reduces blood pressure and heart work. In addition, these drugs cause the kidneys to return less sodium and water to the blood, further reducing the work of the heart. ACE inhibitors conserve potassium, and as mentioned, a normal potassium level is essential for the prevention of digitalis toxicity and the maintenance of the electrical stability of the heart. Available ACE inhibitors include captopril, enalapril, and lisinopril. (See chapter entitled Angiotensin-Converting Enzyme Inhibitors/Angiotensin Receptor Blockers.)

a. Captopril (Capoten)

Supplied: Tablets: 12.5 mg, 25 mg, 50 mg, and 100 mg.

Dosage: Withdraw diuretics and other antihypertensives for 12 h, then give a test dose of 6.5 mg daily, increasing to 12.5 mg twice or three times daily, preferably one hour before meals. The maximum suggested daily dose for heart failure is 75–100 mg. This drug is excreted by the kidneys. If kidney failure is present, the dose interval is increased; for example, 25 mg three times daily can be reduced to 25 mg twice daily or to 12.5 mg twice daily. With kidney failure less drug is needed at longer intervals.

Advice and Adverse Effects: ACE inhibitors are not advisable in patients with severe anemia or severe renal failure. Do not combine with potassium in any form or with water pills that retain potassium. Captopril may cause a dry cough and severe itching of the skin. Increased protein in the urine and reduction in white blood cells may also occur.

b. Enalapril (Vasotec)

Supplied: Tablets: 2.5 mg, 5 mg, 10 mg.

Dosage: 5 mg once or twice daily up to 40 mg daily.

Enalapril is an ACE inhibitor, and its effects are similar to those of captopril, as outlined above.

Other vasodilators used in the management of heart failure include hydralazine, but its effects are variable and only rarely helpful. Hydralazine is not an ACE inhibitor and it is used in heart failure only when ACE inhibitors or ARBs are contraindicated (see the chapter Angiotensin-Converting Enzyme Inhibitors/Angiotensin Receptor Blockers).

c. Lisinopril (Zestril, Prinivil, Carace)

Supplied: Tablets: 5 mg, 10 mg, 20 mg.

Dosage: 2.5 mg once daily increasing as needed to maintenance of 20–40 mg daily. Table 2 gives the names and dosage of ACE inhibitors and ARBs.

D. Angiotensin receptor blockers

ARBs specifically block the angiotensin II receptor AT₁, and this causes a blockade of the renin-angiotensin-aldosterone system. Although, as with ACE inhibitors, the blockade is not complete. Because angiotensin can be synthesized outside of the renin-angiotensin system, ARBs could produce more effective control of angiotensin II than ACE inhibitors and have the potential to be more effective antihypertensive and heart failure agents. In addition they do not cause a dry cough or life-threatening angioedema like ACE inhibitors. The ARB, candesartan, demonstrates long-lasting blockade of the AT₁ receptor and appears to have the most potent blood pressure lowering effects in the ARB class.

d. Candesartan (Atacand Amias)

Supplied: 4 mg, 8 mg, 16 mg, 32 mg.

Dosage: Initial 4–8 mg titrated to 16–32 mg once daily.

e. Irbesartan (Avapro, Aprovel)

Supplied: 75 mg, 150 mg, 300 mg.

Dosage: 150–300 mg daily. Elderly: initial 75 mg.

Only the 300-mg dose has been shown to be effective in causing some degree of renal protection and reduction of microalbuminuria. See the chapter Angiotensin-Converting Enzyme Inhibitors/Angiotensin Receptor Blockers for other agents of this class.

Clinical Trial: CHARM

The Charm-Alternative trial (n=2028) examined the effects of the ARB candesartan in patients with a reduced

left ventricular ejection fraction of less than 40% who were ACE inhibitor intolerant. Results of the study showed that after 33.7 months of follow up patients administered candesartan were 23% less likely to experience the primary end point: cardiovascular death or heart failure hospitalization compared with those who received standard heart failure medications with the exception of ACE inhibitors ($p=0.0004$).

CHARM examined the effect of candesartan on patients who were already on an ACE inhibitor, the majority of whom were on a beta-blocker. After 41 months of follow up patients receiving candesartan were 15% less likely to experience the primary end point compared with those given placebo (42% vs. 37.9; $p=0.0011$). This result occurred regardless of whether or not patients were on a beta-blocker and independent of the dose of ACE inhibitor used. When the combination of candesartan and an ACE inhibitor is administered, however, monitoring of serum creatinine and for hyperkalemia is necessary, particularly if spironolactone or eplerenone are used in the treatment regimen.

E. Diuretics

Diuretics are a very useful category of heart medication. They play a vital role in the treatment of patients with heart failure or hypertension. In heart failure, the legs and lungs become not just waterlogged, but brine-logged. Water in the legs, feet, and lungs can only be relieved by using a diuretic, which forces salt and water from the blood into the urine. Severe shortness of breath and a feeling of suffocation is rapidly relieved by the diuretic furosemide. Diuretics used in conjunction with ACE inhibitors, beta blockers, and digoxin prolong life and cause relief of symptoms.

I. Furosemide (Lasix)

Supplied: Tablets: 20 mg, 40 mg, and 80 mg.

Dosage: 40–120 mg daily for patients with severe congestive heart failure. Long-term maintenance for patients no longer in heart failure is 40–80 mg daily.

F. Nitrates

These preparations (see the chapter Angina) have a small role in patients who are not controlled with the use of digoxin and diuretics, plus an ACE inhibitor. Their main action is to dilate veins, pooling blood in the lower part of the body. This causes less blood to return to the heart and congestion in the lungs may be slightly reduced. This

effect is only mild, however, and the drugs lose effectiveness if used continuously over a few weeks. They are often used in emergencies, in hospitals, or occasionally, at home to help patients with very severe heart failure get over a crisis.

Preparations of oral isosorbide dinitrate and other oral nitrates may be added to digoxin and diuretics and even to the vasodilators mentioned above. Some patients may feel dizzy, however, with drug combination and close supervision by a physician advisable to achieve the best effects.

G. Beta-Blockers

Beta-adrenergic blocking agents play a key role in the management of patients with heart failure and are strongly recommended for the management of New York Heart Association class I–III heart failure. Transmyocardial measurements have documented that the failing human heart is exposed to increased adrenergic activity. Chronic adrenergic activation has adverse effects on the natural course of heart muscle disease. These cardioactive agents block the renin-angiotensin-aldosterone system and augment atrial and brain natriuretic peptide. Clinicians appear to have forgotten that beta-blockers decrease renin secretion from the juxtaglomerular cells of the kidney, which causes a decrease in angiotensin levels and reduces aldosterone production. Recent randomized clinical trials have shown particular beta-blockers are as beneficial as ACE inhibitors for the treatment of heart failure. (See chapter entitled Beta-Blockers.)

The COPERNICUS trial studied 2289 patients with severe heart failure with ejection fractions of 16–24% but free from overt fluid retention or recent treatment with intravenous diuretics. The results showed a highly significant 35% reduction in all-cause mortality caused by the drug, carvedilol.

The CAPRICORN study showed that in patients after myocardial infarction with an ejection fraction of 33% carvedilol caused a 23% relative reduction in mortality identical to that observed with ACE inhibitors. The MERIT-HF trial involved patients with class II and III heart failure with a mean ejection fraction of 28%, which resulted in risk reduction of 33% for total mortality or worsening heart failure. In this trial metoprolol was used in combination with diuretics, digoxin, and an ACE inhibitor.

In the CIBIS-II study of 2647 patients with class III heart failure and an ejection fraction of 35%, bisoprolol administration reduced all-cause mortality by

32% ($p=0.00005$) and sudden death by 45% ($p=0.001$). A 30% reduction in hospitalization occurred in the bisoprolol-treated group. Study patients received ACE inhibitors, diuretics, and digoxin.

COMET was a large randomized trial that compared carvedilol and metoprolol to clinical outcomes in patients with chronic heart failure. The COMET investigators assigned 1511 patients with chronic heart failure New York Heart Association class II–IV to treatment with carvedilol and 1518 to metoprolol. The all-cause mortality was 34% for carvedilol and 40% for metoprolol ($p=0.0017$). Carvedilol showed superior beneficial effects compared to metoprolol and is the beta-blocker of choice for the management of heart failure.

Beta-blockers used judiciously are as effective as ACE inhibitors that are proven useful in the management of heart failure. From the 1960s to the 1980s heart failure was a recognized contraindication for the use of beta-blockers. The first documented use of beta-blockers to treat heart failure was carried out by Dr. Finn Waagstein in Sweden in 1973, and he published a report of treatment in seven patients in 1975. About 25 years later his colleague, Dr. Swedberg, made the comment: “in the light of CIBIS-II, MERIT-HF, and COPERNICUS about 25 years after our initial experience, it is gratifying to realize that beta-blocker therapy now is the best documented and most effective treatment for chronic heart failure.”

H. Aldosterone Antagonists

I. Spironolactone (Aldactone)

This drug blocks the effect of aldosterone in the distal renal tubule (see Figure 1 in the chapter Diuretics). In the Rales study the drug caused a 30% reduction in the risk of death in patients with class III and IV heart failure treated with diuretics, ACE inhibitors, and digoxin. Hospitalization for recurrent heart failure was significantly reduced. This represents a major breakthrough in the management of severe heart failure.

Spironolactone causes potassium retention similar to ACE inhibitors, therefore, hyperkalemia may occur. This combination should be avoided in patients with renal dysfunction.

With spironolactone the beneficial effect in the management of heart failure appears to be the result of the following.

- Distal nephron blockade of aldosterone causes sodium and water excretion. This action is extremely important

in patients treated with furosemide; distal nephron blockade enhances the diuretic effect of loop diuretics and prevents recurrence of heart failure.

- Spironolactone appears to decrease cardiac fibrosis and endothelial dysfunction and increase nitric oxide bioactivity.
- Spironolactone has a mild positive inotropic effect independent of and additive to that of digoxin; stroke volume is increased.

2. Eplerenone (Inspra)

The EPHEsus trial randomized 6000 patients and showed that this selective aldosterone blocker added to optimal medical therapy in patients with acute myocardial infarction and heart failure with ejection fractions less than 35% significantly reduced mortality and morbidity. The dose of 25 mg can be titrated up to 50 mg daily. It does not cause gynecomastia like spironolactone so it may replace spironolactone use in men. Both agents should not be used in patients with a serum creatinine greater than 1.3 mg/dl (115 $\mu\text{mol/L}$) or in type 2 diabetics with altered glomerular filtration rates because hyperkalemia may be precipitated. The serum creatinine does not reflect the creatinine clearance, particularly in the elderly who are most often treated for heart failure. In this randomized trial hyperkalemia occurred in 5.5 and 4% of patients in the treated and placebo groups, respectively.

I. Resynchronization

Cardiac resynchronization therapy is an innovative pacemaker-based approach to the management of patients with left bundle branch block, right bundle branch block, and nonspecific intraventricular conduction delay as manifested electrocardiographically. It appears that resynchronization provides electromechanical coordination and improved ventricular synchrony in patients with intraventricular conduction defects and heart failure. A pacemaker lead is placed through the right atrium through the coronary sinus and into a cardiac vein on the lateral wall of the left ventricle. The left ventricular lead constitutes the key difference between resynchronization therapy and the standard dual-chamber pacing that is used for other conditions requiring a pacemaker. One lead is in the left ventricle, one lead is placed in right atrium, and the third lead is placed in the right ventricle. Beneficial documented effects of resynchronization therapy include reverse remodeling which results in decreased heart size

and ventricular volumes, an improvement in ejection fraction, and a decrease in mitral regurgitation.

Unfortunately in the MIRACLE clinical trial testing resynchronization therapy, 32% of patients had no change or had a deterioration in the New York Heart Association class after resynchronization therapy. In addition, other studies have reported about a 30% nonresponse rate after biventricular pacing. Because of the cost of this modality, an important question to ask is how to determine in advance of implantation which patients will respond to resynchronization therapy. Resynchronization therapy has not been shown to improve survival in patients with heart failure and further trials are underway.

J. Transplantation and the Artificial Heart

Cardiac transplantation is of proven benefit but only approximately 4000 donor hearts are available worldwide annually (see the chapter Artificial Heart).

VIII. NONDRUG THERAPY

A. Advice on Drugs, Salt, Diet, Potassium, Alcohol, and Exercise

Medications must be continued as directed. Herbal remedies are not recommended for the management of heart failure and these substances should be avoided. Do not stop any medications without consulting a physician. Digoxin is usually necessary for a lifetime and diuretics are continued in some in a small dose for a lifetime. We strongly advise you to take your medications with you on each visit to your doctor so that they can be rechecked or altered.

It is essential that the patient learn to live with a low-sodium diet. This does not mean that the individual must go to extremes and follow a 0.5–1 gm sodium diet. To achieve a low salt intake, simply do the following:

- Do not add salt in cooking or at the table. If taste is a problem, use a salt substitute after testing several preparations on the market. Salt substitutes have potassium instead of sodium and are therefore better for you, but they should not be used if you are taking an ACE inhibitor.
- If you have kidney trouble, you retain enough potassium; therefore, extra potassium is not required. It is such an important and confusing area that both patient and physician must be careful. If you are taking an ACE inhibitor (captopril, enalapril), spironolactone, Aldactazide, Dyazide, triamterene, or Moduretic

(Moduretic) do not use excessive amounts of salt substitute, eat a potassium-rich diet, or take potassium supplements without the advice of your doctor. Appropriate advice from your doctor depends on blood tests to evaluate kidney function and electrolytes, which include blood potassium.

- Use foods containing small quantities of sodium. For further information on salt intake, see the chapter Hypertension.

Apart from a low-sodium intake and an increased intake of potassium where necessary, your diet can be normal. There is no need to restrict cholesterol, fats, or sugars because this adds to the patient's misery for little return. Such strict diets may rob the patient of one beauty of life, that is, to be able to enjoy a meal. This can result in a feeling of hopelessness and depression. Diabetics, however, still need to maintain their diets. Patients must lose excess weight to decrease the work of a failing heart. Less weight always causes less shortness of breath. A loss of 10–25 pounds always causes considerable improvement in shortness of breath and less medications are required. The level of potassium in the blood must be kept within the upper normal range, 4–5 mEq/L. Except when kidney failure is present, extra potassium is often required in liquid or tablet form. The tablets or capsules may cause some gastrointestinal irritation. In addition, the pills are large in size and often rejected by patients, and they contain very little potassium. When a patient has a low blood potassium and kidney failure is absent, we strongly advise a potassium-rich diet because the liquid medications have such an unpleasant taste. Foods containing a liberal amount of potassium are given in Table 3.

TABLE 3
Potassium-Rich Foods

	Potassium-Rich	Foods
Orange juice	Half cup	6 mEq
Milk (skim, powdered)	Half cup	27 mEq
Milk (whole, powdered)	Half cup	20 mEq
Melon (honeydew)	Quarter	13 mEq
Banana	One	10 mEq
Tomato	One	6 mEq
Celery	One	5 mEq
Spinach	Half cup	8 mEq
Potato (baked)	Half	13 mEq
Beans	Half cup	10 mEq
Strawberries	Half cup	3 mEq

Avocado, prunes and raisins, meats, and shellfish are rich in potassium.

TABLE 4

KCL-Liquids	Ingredients	mEq (mmol)	mEq (mmol)
Kay Ciel	Kay-Cee-L	KCl20 20	1 mmol/L
Potassium chloride 10% KCl 20 (or sugar free)	K-Lord (piquet's) KCl 20	K-Litchi KCl 25	Koehler 10%
KCl 20 Klorvess 10% KCl 20	Cilium KCl 20	3* Kino Elixir K glaciate 20	—*
Kino-Cl 20% KCl 40	K-Lyte (effervescent)	KH ₂ CO ₃ 25	—*
Potassium Triplex not KCl 15	—*	Potassium Sandoz KCl 12	8*
Rum K	KCl	20	20
Tablets/Capsules—Slow Release			
K-Long KCl	6* 6 Cilium durules KCl	10* 10 Kaon K gluconate	5*—
LeoK KCl 8	8* Micro K KCl	8* 8 Nu-K K 8	8*
SandoK	K	12	8*
Slow-K	KCl	8J	8*

*Note the low potassium and/or chloride content of some preparations.

Dosage: Usual range 20–60 mEq (mmol) potassium daily. K⁺ = potassium. Cl⁻ = chloride.

The intake of foods listed in Table 3 can prevent the use of potassium pills or liquids. As an alternative, many doctors advise a diuretic that retains potassium such as Moduretic or Dyazide. In moderate to severe heart failure, a combination of furosemide, which causes a loss of potassium, and captopril or enalapril, which retains potassium, is advised. Various diuretics are discussed in the chapter Diuretics. Potassium chloride mixtures and tablets are given in Table 4. To be useful, these preparations must contain sufficient potassium with chloride.

Alcohol causes the heart muscle to pump less forcefully. Eight ounces of gin given to normal healthy students caused a 33% reduction in the amount of blood ejected from the heart. Can you imagine a sick heart with a handicap? If you have had heart failure, either do not drink alcohol at all or keep it under two ounces of alcohol, a pint of beer, or two ounces of wine daily. Patients who have alcoholic heart muscle disease (alcoholic cardiomyopathy) should never drink alcohol.

Exercise or unaccustomed activity imposes increased work on a weak heart muscle and often precipitates heart failure. Walking is the safest and best exercise. Try to walk a half to one mile and stop and rest if you get short of breath. It is not recommended to take longer walks of three to five miles or jogging for patients with heart failure. Stopping and bending exercises may cause some dizziness, especially if you are on vasodilators, diuretics, and nitrates. Patients with class III or IV heart failure, especially if recurrent, are not advised to engage in exercise programs even if they are claimed to be rehabilitation programs. Walking a half to one mile daily and stretch exercises should suffice. You can only strain the heart muscle; you can never improve it. The heart failure that occurs during

an acute heart attack is completely different and often clears within one week. Such patients can engage in various exercise programs.

IX. WHAT TO EXPECT IN THE HOSPITAL AND ON DISCHARGE

The main symptom of heart failure is severe shortness of breath. Pain occurs only when heart failure is precipitated by a heart attack. If nitroglycerin is available, put one under the tongue and remain propped up in bed or sit until the ambulance arrives.

Oxygen is useful and is given immediately at onset of heart failure. Morphine allays anxiety and pools blood in the lower part of the body. Both of these actions bring relief. Nitroglycerin paste, ointment, or patch is applied to the skin, and a powerful diuretic, furosemide, is given intravenously. Furosemide acts within minutes, pooling blood in the lower half of the body, and causes the kidneys to remove sodium and water from the blood and excrete them in the urine. If relief is not obtained, further injections of furosemide are given.

The cause of heart failure and the precipitating factors are then treated, if possible. Atrial fibrillation is successfully treated with digoxin. Hypertension can cause heart failure, and the blood pressure must be lowered. An ACE inhibitor is used to dilate arteries and lower blood pressure, and thus rest the heart. Patients with heart failure have a hospital stay of five to 7 days. Prognosis depends on the cause and precipitating factors outlined. Heart failure does not mean the end. Some patients do much less than before,

but they can live active lives for 5–15 years with good medical treatment. The reassuring news is that avoidance of precipitating factors can help enormously and the recent use of judicious doses of carvedilol or metoprolol along with spironolactone or eplerenone will have a major impact in improving morbidity and mortality from heart failure.

BIBLIOGRAPHY

- Abraham, W. T., Fisher, W. G., Smith, A. L. et al. Cardiac resynchronization in chronic heart failure. *N. Engl. J. Med.*, 346:1845–53, 2002.
- Adams, K. F., Gheorghide, M., Uretsky, B. F. et al. Clinical benefits of low serum digoxin concentrations in heart failure. *J. Am. Coll. Cardiol.*, 39:946–53, 2002.
- Bauersachs, J., Heck, M., Fraccarollo, D., Hildemann, S. K. et al. Additions of spironolactone to angiotensin-converting enzyme inhibition in heart failure improves endothelial vasomotor dysfunction. *J. Am. Coll. Cardiol.*, 39:351–8, 2002.
- Brad, G., Angeja, M. D. and Grossman, W., Evaluation and management of diastolic heart failure. *Circulation*, 107:659, 2003.
- Borbély, A., van der Velden, J., Papp, Z. et al. Cardiomyocyte stiffness in diastolic heart failure. *Circulation*, 111:774–781, 2005.
- Bradley, D. J., Bradley, E. A. Baughman, K. L. et al. Cardiac resynchronization and death from progressive heart failure. A meta-analysis of randomized controlled trials. *JAMA*, 289:730–740, 2003.
- Bursi, F., Enriquez-Sarano, M., Nkomo, V. T. et al. Heart failure and death after myocardial infarction in the community: The emerging role of mitral regurgitation. *Circulation*, 111:295–301, 2005.
- Campbell, D. J. How should I combine beta-blockers, ACE inhibitors and ARBs in the management of heart failure? *J. Am. Coll. Cardiol. ACC Curr. J. Rev.*, May/June, 55–58, 2003.
- CAPRICORN: Effect of carvedilol on outcome, after myocardial infarction in patients with left ventricular dysfunction. *Lancet*, 357:1385, 2001.
- Cleland, J. G. F. and Others et al. The effect of cardiac resynchronization on morbidity and mortality in heart failure. *N. Engl. J. Med.*, 352: late March–April, 2005.
- Gheorghide, M., Adams, Jr., K. J., and Colucci, W. S. Digoxin in the management of cardiovascular disorders. *Circulation*, 109:2959–2964, 2004.
- Granger, C. B., McMurray, J. J. V., Yusuf, S. et al. For the CHARM investigators and committees. Effects of candesartan in patients with chronic heart failure and reduced left ventricular systolic function intolerant to angiotensin converting enzyme inhibitors; the CHARM-alternative trial. *Lancet*, 362:772–776, 2003.
- Hogg, K., Swedberg, K., and McMurray, J. Heart failure with preserved left ventricular systolic function: epidemiology, clinical characteristics, and prognosis. *J. Am. Coll. Cardiol.*, 43:317–327, 2004.
- Hunt, S. A., Abraham, W. T., Chin, M. H., et al. ACC/AHA 2005 guideline update for the diagnosis and management of chronic heart failure in the adult—Summary article: A report of the American College of Cardiology/American Heart Association task force on practice guidelines (writing committee to update the 2001 guidelines for the evaluation and management of heart failure). *J. Am. Coll. Cardiol.*, 46: 1116–1143, 2005.
- Hunt, S. H., Baker, D. W., Chin, M. H. et al. ACC/AHA guidelines for the evaluation and management of chronic heart failure in the adult: executive summary: a report of the American College of Cardiology/American Heart Association task force on practice guidelines. *J. Am. Coll. Cardiol.*, 38:2101, 2001.
- Jessup, M., and Brozena, S. Heart failure. *N. Engl. J. Med.*, 348:2007–18, 2003.
- Khan, M. Gabriel *Heart Failure in Cardiac Drug Therapy*, sixth edition. W. B. Saunders, Philadelphia, 2003.
- Khand, A. U., Rankin, A. C., Martin, W. et al. Carvedilol alone or in combination with digoxin for the management of atrial fibrillation in patients with heart failure? 42: 1944–1951, 2003.
- Lokuta, A. J., Maertz, N. A., Meethal, S. V. et al. Increased nitration of sarcoplasmic reticulum Ca²⁺-ATPase in human heart failure. *Circulation*, 111:988–995, 2005.
- Maisel, A. S., Krishnaswamy, P., Nowak, R. M. et al. Rapid measurement of B-type natriuretic peptide in the emergency diagnosis of heart failure. *N. Engl. J. Med.*, 347:161–7, 2002.
- Masoudi, F. A., Inzucchi, S. E., Wang, Y. et al. Thiazolidinediones, Metformin, and outcomes in older patients with diabetes and heart failure: An observational study. *Circulation*, 111:583–590, 2005.
- Maurer, M. S., Spevack, D., Burkhoff, D. et al. Diastolic dysfunction: Can it be diagnosed by Doppler echocardiography? *J. Am. Coll. Cardiol.*, 44:1543–1549, 2004.
- McCullough, P. A., Philbin, E. W., Spertus, J. A. et al. Confirmation of a heart failure epidemic: Findings from the resource utilization among congestive heart failure (REACH) study. *J. Am. Coll. Cardiol.*, 39:60–9, 2002.
- McMurray, J. J. V., Pfeffer, M. A., Swedberg, K. L. et al. Which inhibitor of the renin–angiotensin system should be used in chronic heart failure and acute myocardial infarction? *Circulation*, 110:3281–3288, 2004.
- MERIT-HF: The metoprolol CR/XL randomized intervention trial in congestive heart failure. Effects of controlled release metoprolol on total mortality hospitalizations and well being in patients with heart failure. *JAMA*, 283:1295, 2000.
- Morrison, L. K., Harrison, A., Krishnaswamy, P. et al. Utility of a rapid B-natriuretic peptide assay in differentiating congestive heart failure from lung disease in patients presenting with dyspnea. *J. Am. Coll. Cardiol.*, 39: 202–209, 2002.
- Packer, M., Coats, J. S., Fowler, M. B. et al. For the carvedilol prospective randomized cumulative survival study group (COPERNICUS): Effect of carvedilol on survival in severe chronic heart failure. *N. Engl. J. Med.*, 344:1651, 2001.
- Pitt, B., Remme, W., Zannad, F. et al. For the eplerenone post acute myocardial infarction heart failure efficacy and survival study (EPHESUS) investigators. Eplerenone, a selective aldosterone blocker in patients with left ventricular dysfunction after myocardial infarction. *N. Engl. J. Med.*, 348:1309–21, 2003.
- Pitt, B., Zannad, F., Remme, W. J. et al. For the randomized evaluation study investigators; the effect of spironolactone on morbidity and mortality in patients with severe heart failure. *N. Engl. J. Med.*, 341:709, 1999.
- Rahimtoola, S. H. Digitalis therapy for patients in clinical heart failure. *Circulation*, 109:2942–2946, 2004.
- Redfield, M. M., Rodeheffer, R. J., Jacobsen, S. J. et al. Plasma brain natriuretic peptide concentration: impact of age and gender. *J. Am. Coll. Cardiol.*, 40:976–82, 2002.
- Regula, K. M., Baetz, D., Kirshenbaum, L. A. et al. Nuclear factor-κB represses hypoxia-induced mitochondrial defects and cell death of ventricular myocytes. *Circulation*, 110:3795–3802, 2004.

- Ripoli, A., Pingitore, A., Favilli, B. et al. Does subclinical hypothyroidism affect cardiac pump performance? *J. Am. Coll. Cardiol.*, 45:439–445, 2005.
- Shekelle, P. G., Rich, M. W., Morton, S. C. et al. Efficacy of angiotensin converting enzyme inhibitors and beta-blockers in the management of the left ventricular systolic dysfunction according to race gender, and diabetic status. *J. Am. Coll. Cardiol.*, 41:1529–38, 2003.
- Strey, C. H., Young, J. M., Molyneux, S. L. et al. Endothelium-ameliorating effects of statin therapy and coenzyme Q₁₀ reductions in chronic heart failure. *Atherosclerosis*, 179: Issue 1, 201–206, 2005.
- Swedberg, K. Beta blockers in heart failure. How it all began. *J. Am. Coll. Cardiol., ACC Curr. J. Rev.* January/February, 61, 2001.
- Valgimigli, M., Ceconi, C., Malagutti, P. et al. Tumor necrosis factor- α receptor 1 is a major predictor of mortality and new-onset heart failure in patients with acute myocardial infarction: The cytokine-activation and long-term prognosis in myocardial infarction (C-ALPHA) study. *Circulation*, 111:863–870, 2005.
- Weinstein, A. R., Sesso, H. D., Lee, I. M. et al. Relationship of physical activity versus body mass index with type II diabetes in women. *JAMA*, 292:1188–1194, 2004.
- Wikstrand, J., Hjalmarson, A., Waagstein, F. et al. Dose of metoprolol CR/ZL and clinical outcomes in patients with heart failure. *J. Am. Coll. Cardiol.*, 40:491, 2002.
- Young, J. B., William, T., Abraham, M. D., Smith, A. L. et al for The Multicenter InSync ICD Randomized Clinical Evaluation (MIRACLE ICD) Trial Investigators Combined Cardiac Resynchronization and Implantable Cardioversion Defibrillation in Advanced Chronic Heart Failure. The MIRACLE ICD Trial. *JAMA*, 289:2685–2694, 2003.

Hemochromatosis

- I. Incidence
- II. Genetics and Iron Overload
- III. Clinical Complications
- IV. Management
- V. Research Implications

GLOSSARY

arrhythmia general term for an irregularly or rapidly of the heartbeat, an abnormal heart rhythm.

cardiomyopathy heart muscle disease.

ejection fraction the fraction of blood ejected from the heart into the arteries, normally this ranges from 60–75%; a low ejection fraction is less than 40%; often used as a marker of left ventricular contractility.

heart failure failure of the heart to pump sufficient blood from the chambers into the aorta; inadequate supply of blood reaches the organs and tissues.

myocardium the heart muscle.

HEMOCHROMATOSIS IS A CONDITION CAUSED by a genetic defect in which excessive amounts of iron are absorbed in the small intestine and deposited in tissues and organs of the body. Iron overload has several causes one of which is repeated and excessive blood transfusions, as may occur in individuals with sickle cell anemia and beta-thalassemia major. Also, excessive alcohol consumption may increase the blood levels of iron because alcohol stimulates iron absorption. In addition, red wines contain increased amounts of iron. The containers in which alcoholic beverages are kept may also contain iron and increase the iron content of the beverage. The use of cooking utensils with an iron base from which iron may leach can increase blood levels of iron and deposition in the tissues. Such a condition was noted several years ago in the Bantus who used iron pots for preparation of meals.

I. INCIDENCE

Hereditary hemochromatosis is not an uncommon condition. Approximately 10% of individuals of European and particularly Celtic background are heterozygous carriers who only develop iron overload if there is a second defect added to environmental and nutritional factors.

Homozygosity is about 1 in 400. Fortunately, the number of individuals affected clinically is much less than predicted by the genetic frequency, perhaps, because of variable penetrance and other unknown factors. The frequency of the clinical disease was estimated to be roughly 1 in 5000 in the Pacific Northwest of the United States and 1 in 500 and 1 in 1000 in autopsy series in Scotland and Sweden, respectively. The majority of affected homozygotes do not exhibit signs or symptoms; the disease may therefore go undetected. The development of clinical hemochromatosis with damage to organs usually requires a double dose of the mutant gene and affected parents are homozygous. Individuals of Asian and African background are rarely affected.

II. GENETICS AND IRON OVERLOAD

The gene responsible for hemochromatosis, HFE, was discovered in 1996 and resides in chromosome 6 which involves the mutation of a cysteine to tyrosine at position 282 (C282Y). Iron is kept in a soluble state in the blood because it binds to the protein transferrin. Cellular iron uptake takes place at transferrin receptors. Figure 1 shows the transferrin shuttle pathway. Normally iron is separated from transferrin in the endosome and is shuttled into the interior of the cell.

The genetic mutation C282Y produces a mutant *HFE* protein that is not associated with the transferrin receptor and does not act as a brake on iron uptake into cells. The exact reason why iron absorption in the intestine is markedly increased has not been clarified and requires further investigation and research.

III. CLINICAL COMPLICATIONS

A. Myocardial Damage Mechanisms

Iron-saturated transferrin attaches to cell transferrin receptors and excess iron gains entry into the cell (see Fig. 1).

Although much of the iron is stored as hemosiderin, for example, within the Kuffer cells of the liver, and causes no damage to tissues, some free iron is released into parenchymal cells. Free iron catalyzes the formation of reactive oxygen species and the hydroxyl radical causes damage to cells. With damage and destruction of cells there is

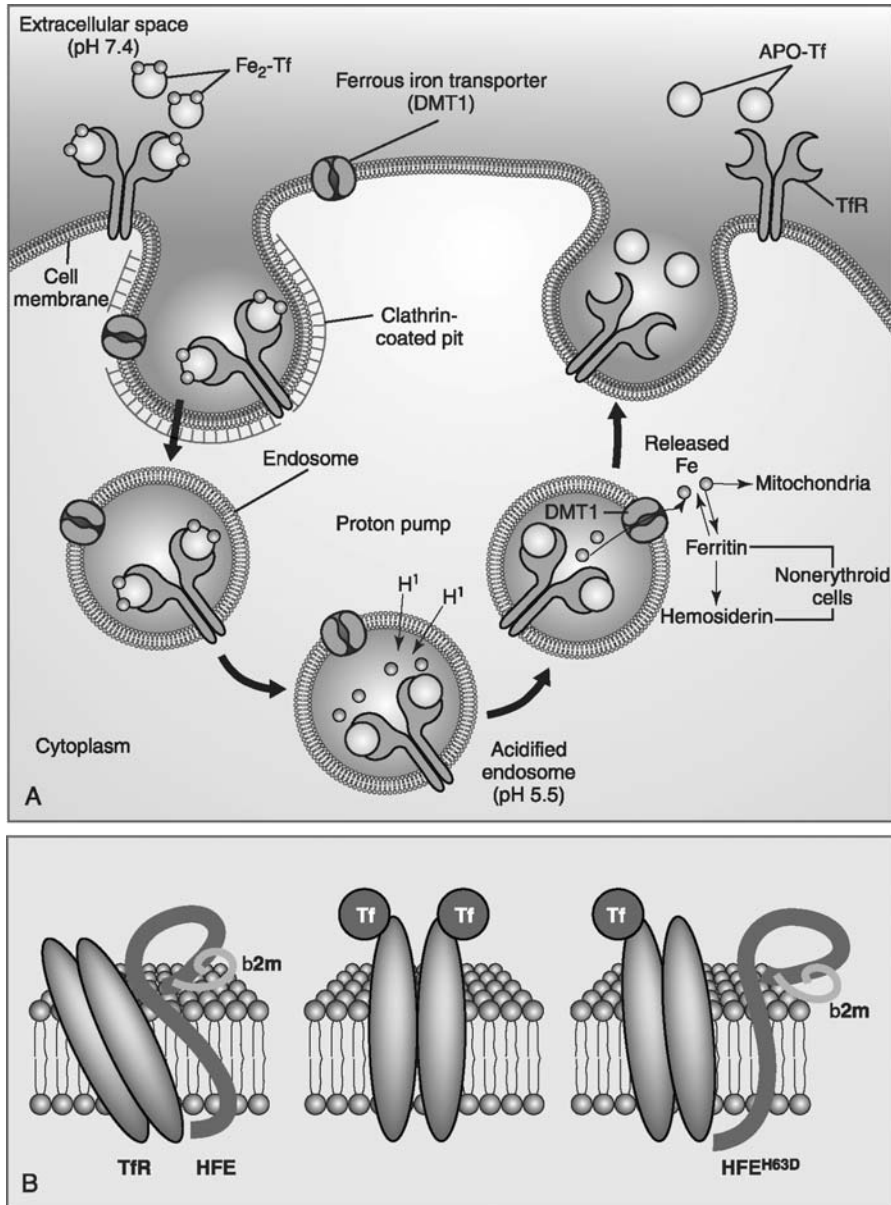

FIGURE 1 (A) The transferrin shuttle pathway. Iron is released from its transferrin-bound state in the circulation intracellularly in endosomes due to proton-pump-mediated acidic pH. The HFE protein, mutated in hemochromatosis, acts as a brake on iron internalization by binding to transferrin receptors. (From Andrew, N. C. Medical progress: Disorders of iron metabolism. *N. Engl. J. Med.*, 341, 1985–1986, 1999.) (B) The transferrin receptor (TfR)-HFE complex. Wild-type HFE protein is associated with beta₂-microglobulin and binds to TfR, decreasing transferrin binding (left). The C282 mutant HFE protein does not associate with beta₂-microglobulin, allowing TfR free to bind transferrin (center). The H63D mutant HFE does associate with beta₂-microglobulin but fails to decrease TfR affinity for transferrin (right). (From Andrews, N. C., and Levy, J. E., Iron is hot: An update on the pathophysiology of hemochromatosis. *Blood*, 92, 1845–1851, 1998.)

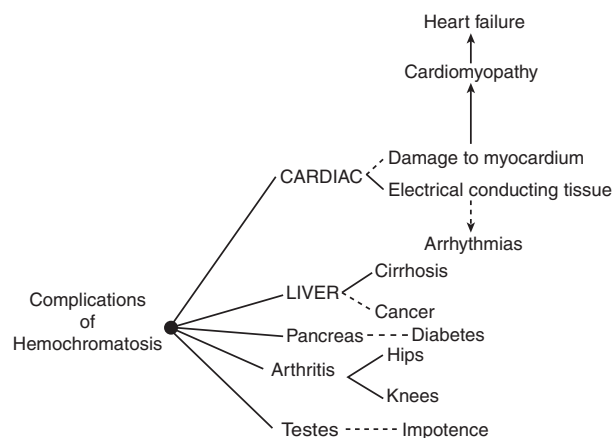

FIGURE 2 Complications of hemochromatosis.

replacement by collagen and fibrous tissue that weakens the muscular wall of the heart. Severe damage and weakness primarily to heart muscle is called cardiomyopathy. Less blood is ejected from the left ventricle and heart failure symptoms and signs occur. The weakened heart muscle is stretched and the heart becomes dilated, resulting in a dilated cardiomyopathy, but some restriction to filling of the heart occurs and there are also features of a restrictive cardiomyopathy (see the chapter Cardiomyopathy). Excessive iron is distributed throughout the myocardium and in the electrical conducting tissues and arrhythmias may occur.

B. Symptoms and Signs

The symptoms and signs of hemochromatosis depend on the organ or organs involved. It usually takes 20–30 years of excessive absorption before the disease manifests. In affected women time onset is usually delayed because of menstruation.

Figure 2 shows the clinical complications of hemochromatosis. Complications of heart failure such as shortness of breath, fatigue, and edema of the ankles as well as other symptoms and signs of heart failure occur. Palpitations caused by arrhythmias may be bothersome and serious arrhythmias can cause death. Signs and symptoms due to other organ involvement include pigmentation of the skin, diabetes because of involvement of the pancreas, enlargement of the liver and cirrhosis may cause fluid to accumulate in the abdomen, and ascites and cancer of the liver may be terminal. Arthritis may be severe with

iron replacing the cartilage of the hip and destroying the hip or knee joint.

C. Diagnosis

Serum ferritin, normally 16–320 $\mu\text{g/L}$ is usually elevated to more than 700 $\mu\text{g/L}$ and may reach as high as 5000 $\mu\text{g/L}$. A liver biopsy usually confirms the type of damage caused by hemochromatosis and the genetic causation is confirmed by gene testing.

Disturbance in the heart can be detected by echocardiography or radionuclide ventriculography, both of which show left ventricular dysfunction. The MRI is more specific; iron that is localized in the myocardium and liver generates a characteristic signal dropout pattern so that the liver and in part, the myocardium, become invisible.

IV. MANAGEMENT

Venesection with removal of 500 ml of blood every 2 weeks for several months followed by monthly venesection for a year usually results in a reduction of serum ferritin level to less than 50 $\mu\text{g/L}$. Venesections are continued every 3 months or more frequently to maintain a ferritin level 50 $\mu\text{g/L}$ range. Alcohol increases absorption of iron and should be curtailed, especially because cirrhosis is an outcome of the iron overload. If the serum iron is kept within the normal range before serious cardiac involvement has occurred, the prognosis is good. If cardiomyopathy resulting in heart failure has occurred, the prognosis is poor.

Iron chelation may reverse some degree of cardiac dysfunction. Intravenous desferrioxamine on a 24-h per day regimen resulted in some improvement in left ventricular dysfunction and improvement in ejection fraction in some patients with severe cardiac dysfunction caused by transfusional iron overload.

BIBLIOGRAPHY

- Andrews, N. C. Disorders of iron metabolism. *N. Engl. J. Med.*, 341:1986–95, 1999.
- Andrews, N. C., and Levy, J. E. Iron is hot. An update on the pathophysiology of hemochromatosis. *Blood*, 92:1845–51, 1998.

Herbal, Dietary Supplements, and Cardiovascular Disease

- I. Historical
- II. Consumption and Regulation
- III. Benefits, Adverse Effects, and Drug Interactions
- IV. Substances Used by Athletes

sympathomimetic impulses from the sympathetic nervous system, adrenergic.

vasoconstriction narrowing, decrease in the diameter of veins or arteries.

GLOSSARY

angina chest pain caused by temporary lack of blood to an area of heart muscle cells, usually caused by severe obstruction of the artery supplying blood to the segment of cells.

arrhythmia general term for the irregularity or rapidity of the heartbeat, an abnormal heart rhythm.

arterial dilatation enlargement or increase in the luminal diameter of the artery.

dyslipidemia the same as hyperlipidemia, elevated blood cholesterol, LDL cholesterol, triglycerides, or low HDL cholesterol.

flavonoid any of a large group of crystalline compounds found in plants.

free radical an atom or group of atoms that is highly chemically reactive, because it has at least one unpaired electron; free radicals can attack cells.

free radical scavenger a substance that removes or destroys free radicals.

heart failure failure of the heart to pump sufficient blood from the chambers into the aorta; inadequate supply of blood reaches organs and tissues.

hypertension high blood pressure.

hypotension marked decrease in blood pressure, usually less than 95 mmHg.

inotropic an effect that affects the force of muscular contractions; negative inotropic refers to decreased myocardial contractility that may lead to poor pumping of the blood, reduced ejection fraction, and heart failure.

myocardial infarction death of an area of heart muscle due to blockage of a coronary artery by blood clot and atheroma; medical term for heart attack or coronary thrombosis.

platelet aggregation clumping together of small particles in the blood; platelets increase clot formation.

I. HISTORICAL

In 350–377 BC, Hippocrates, the father of medicine, advised the use of diet and plant medicines. He tried to relieve the pain of his patients by asking them to chew willow bark, which contains salicylic acid. Long before Hippocrates, the ancient Sumerians (5000 BC), Egyptians, and the Chinese (1600–700 BC) were noted to use herbs such as onions, garlic, licorice, ginger, thyme, and Ayurveda was commonly used in India.

In 1640, Nicholas Culpeper published the *English Physician People's Herbal*. In 1763 Reverend Stone of Chipping Norton, England, showed the benefit of willow bark (salicylic acid) for individuals with ague fever. In 1775 William Withering, a Birmingham physician, learned of a midwife whose herbal brew had cured several people suffering from dropsy which caused severe swelling of the legs and shortness of breath. Withering studied the brew and concluded that the only active constituent of the 20 or more herbs was derived from the foxglove plant, *Digitalis purpurea*. He used the herb with a fair amount of success. For the past 210 years digitalis (digoxin) has been used worldwide to treat millions of people with heart failure.

II. CONSUMPTION AND REGULATION

Alternative therapies with herbal, dietary, and vitamin supplements have escalated considerably in the western world during the past 10 years. Alternative therapies were used in more than 40% of adults in the United States during 1997, and a consumer poll in 1998 indicated that

more than 30% of respondents use herbal remedies. In the United States the use of herbal therapy in 1997 was 12% vs. 2.5 percent in 1990, at a consumer cost of greater than \$5 billion. During 2001, more than \$17 billion was spent on dietary supplements with greater than \$4.2 billion spent for herbal remedies in the United States.

It appears that of patients who take prescription medications, nearly 20% use herbal remedies, high-dose dietary supplements, or both. More important, adverse drug interactions involving prescribed medications and herbal remedies are common. It is estimated that more than 20 million adults in North America are at risk for these adverse interactions, some of which are cardiovascular. In 2001, the Food and Drug Administration (FDA) issued warnings about nephrotoxic and other toxic and carcinogenic effects associated with products containing, kava, comfrey, and aristolochic acid. Reportedly approximately 33% of Asian medicines contain toxic heavy metals such as arsenic, lead, and mercury that have deleterious cardiovascular effects. Drugs such as ephedrine, chlorpheniramine, and testosterone are also contained in so-called herbal remedies.

Because most herbal products are considered dietary supplements rather than medicines, they are not required to meet standards specified in the Federal Food, Drug, and Cosmetic Act. The manufacturer of an herbal or dietary supplement can market the product as long as there is no claim of effectiveness for the prevention and treatment of a specific disease. In Australia, France, Germany, and Sweden strategies have been put in place for licensing herbal remedies.

Reportedly, 75% of the world's population uses herbal remedies. More than 25% of individuals in most countries develop cardiovascular disease. Therefore, the potential value of herbal medicines and dietary supplements to assist with the management of cardiovascular disease, their adverse effects, and interactions with prescribed cardiovascular medicines must be carefully defined.

III. BENEFITS, ADVERSE EFFECTS, AND DRUG INTERACTIONS

A. Danshen (*Salvia miltiorrhiza*)

Danshen is believed to possess vasoactive, free radical scavenger, and demonstrable antiplatelet properties. It is widely used in China for the management of angina and acute myocardial infarction. The active substances of Danshen are phenolics and tanshinones, which cause generalized dilatation of arteries and thus decreases blood pressure. But at high doses it causes vasoconstriction in

noncoronary arteries. This substance has no inotropic effect, and does not increase cardiac contractility. The possibility of coronary artery vasodilatation with Danshen requires further investigation.

I. Benefits and Adverse Reactions

Transhinone, in a double-blind study of 67 patients with coronary artery disease, produced symptomatic and electrocardiographic benefits. A decrease in the clearance of warfarin and increased bioavailability may cause bleeding in this substance.

B. *Ephedra sinica* (Ma Huang)

The active constituent in this herbal medicine is ephedrine, a known stimulant that possesses strong sympathomimetic activity with properties similar to epinephrine. Figure 1

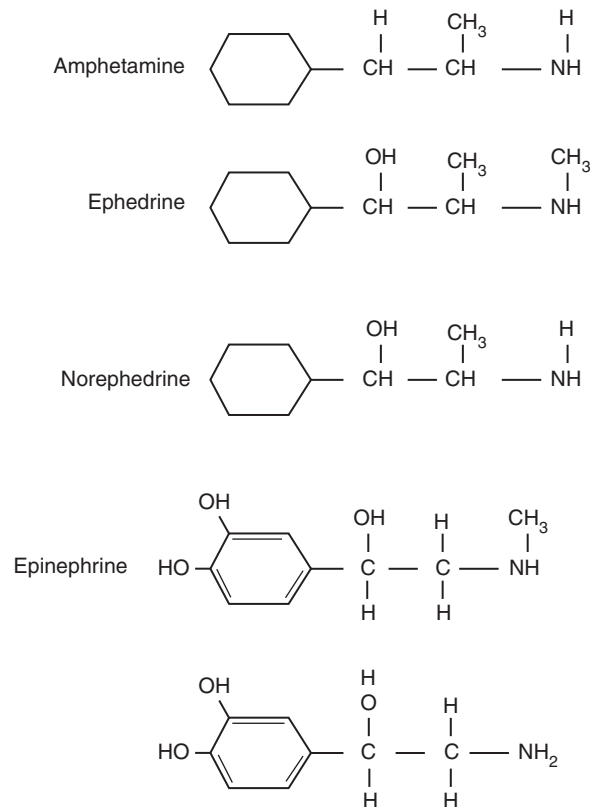

FIGURE 1 Structure of epinephrine and non-epinephrine. Both hormones and neurotransmitters are catecholamines and possess a ring structure containing two -OH groups. They are synthesized from tyrosine. They are cardiac stimulants; they are engaged in several actions in the body including the fight or flight response. Note the stimulants amphetamine and ephedrine.

shows that the molecular structure of ephedrine is similar to that of amphetamine and the related ephedra alkaloid and metabolite, phenylpropranolamine. The latter is found commonly in nasal sprays and in cough mixtures, and has recently (in 2000) been removed from products because of warnings from the FDA, Health Canada, and other health authorities.

Its effects on both alpha- and beta-adrenergic receptors and its central actions resemble those of amphetamines. Unfortunately several dietary supplements and soft drinks contain ephedra alkaloids and are widely used in the United States for increasing energy and to achieve weight loss. The FDA has proposed limits on the dose and duration of use of such supplements. Ephedrine is also found in unapproved herbal products that contain caffeine (herbal ecstasy) and aspirin; other products include *Sida cordifolia* and epitonin.

I. Benefits

Products containing ephedra or ephedrine are marketed only as nasal decongestants and should be used for this purpose only for two to a maximum of seven days. High-dose preparations have been curtailed by the FDA and Health Canada. The dose should be restricted to 8 mg of ephedrine per dose with a maximum 32 mg per day.

2. Adverse Effects and Interactions

Cardiovascular events ranging from hypertension, cerebral hemorrhage, arrhythmias, myocardial infarction, and cardiomyopathy have been observed. In a review of 140 reports related to the use of ephedra alkaloids from 1997 to 1999, 31% of cases were considered to probably be related and 47% involved cardiovascular symptoms. There were also 17 reports of hypertension followed by palpitations, tachycardia, or both. Ten events resulted in death and 13 events produced permanent disability.

Interactions occur with caffeine and theophylline. Some of the adverse effects may be caused by concurrent use of excess caffeine; guarana is a source of caffeine and theophylline. Herbal ecstasy contains caffeine, and other sources include green tea, cola nut, yerba mate, and yohimbe.

C. Ginkgo

I. Benefits

Ginkgo biloba (maidenhair tree) leaf extracts, reportedly, have been used for more than 3000 years by the Chinese,

and it is the best-selling remedy in the United States. Ginkgo is believed to be rich in flavonoids and terpenoids, which are believed to exert their salutary effects through free radical scavenging, antiplatelet activity, vasodilatation, decreased blood viscosity, and anti-inflammatory actions. Inhibition of monoamine oxidase-B and gamma-aminobutyric acid receptor agonist have been reported. Mild antiplatelet activity has been observed, but a placebo-controlled trial reported no effects on platelet aggregation, but an antiplatelet effect is the likely mechanism underlying intracranial hemorrhage which has been observed with the use of ginkgo, albeit rarely.

In the new millennium ginkgo is commonly tried by patients who are not sufficiently benefited by current medical therapy for peripheral vascular and cerebrovascular disease.

Intermittent claudication is a peripheral vascular disease in which pain occurs in the calf muscle after walking from 50 to 100 yards. The pain eases off quickly within minutes of stopping. Meta-analysis indicates that randomized controlled trials (RCTs) in patients with intermittent claudication have had mixed results. A modest improvement in pain-free walking distance increased by 45 and 61 m, respectively, after 24 weeks of ginkgo treatment, compared with increases of 21 and 25 m, respectively, in the placebo group. A meta-analysis of modestly beneficial prescribed medicines concluded that ginkgo improves pain-free walking distance by 32 m, but this effect was much less than pentoxifylline (208 m) and naftidrofuryl (101 m). An RCT showed that a standardized extract of ginkgo significantly reduced the areas of limb ischemia, as measured by transcutaneous partial pressure of oxygen during exercise.

Alzheimer's disease is a cerebrovascular disease for which ginkgo has been used. There has been conflicting evidence for improved cognition and memory. In two long-term RCTs, modest but positive effects were identified in patients with multi-infarct dementia or Alzheimer's disease. These results were not corroborated by a further trial, although age-associated memory impairment has been criticized as a broad and ambiguous concept.

2. Adverse Cardiovascular Effects

Cerebral hemorrhage, subarachnoid hemorrhage, subdural hematomas, and hemorrhage within the anterior chamber of the eye have been reported, but the exact incidence appears rare and is difficult to appreciate from case reports. In patients where intracranial bleeding has occurred the prothrombin time (PT) and partial thromboplastin times (PTT) were normal, but the bleeding time

was higher with a longer return to normal after discontinuation of the herbal medicine.

Increased bleeding has been documented when ginkgo is combined with aspirin, warfarin, or nonsteroidal inflammatory agents (e.g. ibuprofen) as well as the new selective agents such as rofecoxib (Vioxx). Because of an increased risk of bleeding, ginkgo should be discontinued one week prior to surgical procedures.

D. Garlic (*Allium sativum*)

Garlic is one of the most widely used dietary supplements. In 1998 market sales of garlic in the United States reached approximately \$84 million. The active substance in garlic is allicin formed by the action of alliinase on alliin when garlic is crushed. Other active substances in garlic include methyl allyl trisulfide, other disulfides, and ajoene. Doses of 300–900 mg daily of allicin content reportedly cause mild reduction in total cholesterol, mild reduction in blood pressure, and appear to have favorable effects on atherosclerosis. Methyl allyl trisulfide reportedly dilates blood vessels and causes mild reduction in blood pressure. Garlic is a component of the Mediterranean diet, which has been shown to reduce risk of cardiac events.

I. Benefits

Garlic is beneficial in the treatment of dyslipidemia. Evidence from several meta-analyses, each using different criteria, arrived at consistent conclusions that garlic reduces total cholesterol by approximately 10%. If this is indeed factual, it is an impressive reduction in cholesterol judging that the best that a strict low-saturated fat, low-cholesterol diet can do is only 10%. With the advent of powerful cholesterol-reducing agents such as the statins, we are now able to achieve 20–40% reductions. Thus, today a 10% reduction is a modest beneficial effect. Meta-analysis, however, of studies with poor methodological quality are fraught with danger.

Dried garlic powder, 900 mg daily for 12 weeks, reduced blood cholesterol from 282 mg/dl to 210 mg/dl, whereas a fibrate, bezafibrate, caused a reduction from 287 mg/dl to 208 mg/dl. The effect on LDL cholesterol and an increase in HDL cholesterol was similar for both agents. Garlic also reduced elevated blood triglyceride levels, but the effect was a little less than that observed with bezafibrate, 29% versus 42%. It appears that the constituents of garlic can cause beneficial effects on dyslipidemia that are similar to drugs which include fibrates.

A well-designed RCT in England showed no beneficial effects from garlic. A total of 115 men and women with a mean age of 53 years were treated with dried garlic powder for 6 months. The pretreatment cholesterol values were 6–8.5 mmol/L; the trial was of sufficient size to have 90% power to detect a difference of 0.6 mmol/L. No significant differences in lipid concentrations were observed between the groups in what is believed to be the best well-run trial of garlic. A small but well-designed crossover trial done in Australia also showed no beneficial effects.

Even standardized garlic products may contain different quantities of allicin and therapeutic activity because of differences in tablet formulation. A more standardized and tested product may have a role in cholesterol reduction, because the product does not appear to cause harm.

Garlic can cause mild reduction in hypertension. It inhibits platelet nitric oxide synthase, which is known to be a powerful vasodilator. This results in a mild reduction in blood pressure that may be observed in individuals taking large doses (>2000 mg) of garlic powder. The blood pressure lowering effect is so mild that it is not an advisable strategy to use garlic. Several studies have shown no significant antihypertensive effect regardless of formulation or dose. A meta-analysis that only involved two trials with hypertensive patients reports a systolic blood pressure reduction of 7.7 mmHg and a diastolic reduction of 5 mmHg. This study had no comparison with antihypertensive agents.

Anticoagulant and antiplatelet activity are said to be affected by garlic. The active trisulfides and disulfides in garlic appear to inhibit thromboxane synthesis, which confers modest antiplatelet activity. Some constituents of garlic may inhibit binding of fibrinogen to platelet receptors. Dried garlic powder was shown to decrease platelet aggregation in three controlled trials, but no difference was followed in 14 healthy men. Some trials indicate a modest fibrinolytic activity, but conclusive evidence is lacking.

Although the effects on lipid lowering may cause beneficial effects on the atherosclerotic process, there appears to be a salutary effect independent of lipid lowering. Garlic probably inhibits lipid peroxidation. The administration of garlic for 4 years has been shown to reduce femoral and carotid artery atheroma by 5–18%.

Reportedly, a small study in India involved 432 patients with myocardial infarction. In this study 216 patients were given 6–10 garlic cloves daily and the other group received a garlic-scented placebo. There were 45% fewer deaths and a 32% reduction in the recurrence of myocardial infarction in patients administered garlic.

2. Adverse Effects and Interactions

Garlic has mild antiplatelet activity and if used as a medicine (100–1000 mg), it should not be administered concomitantly with antiplatelet agents which include aspirin, clopidogrel, and nonsteroidal anti-inflammatory agents. Garlic must be avoided in patients on anticoagulants. The excessive use of garlic has been observed to cause increased postoperative bleeding and occasionally spontaneous hemorrhage has been reported. Garlic supplements should be discontinued two weeks prior to surgical procedures.

E. Ginger (*Zingiber officinale*)

I. Benefits and Adverse Effects

Decreased platelet aggregation and inhibition of thromboxane synthesis has been observed in *in vitro* studies, but clinical studies have not shown these effects and do not indicate beneficial or harmful effects on the cardiovascular system. Ginger has been advocated mainly to relieve nausea and motion sickness. It is alleged to be a blood thinner, but this claim has not been substantiated.

F. Ginseng (*Panax ginseng*)

This is a well-known herb that is used to enhance wellness. But in China, where it is believed to have been used for more than 3000 years, it is now used in the management of heart failure, heart attack, angina, and left ventricular diastolic dysfunction with promising results. Panax appears to increase synthesis of nitric oxide, and this may be the explanation for its mild antihypertensive effect. The active substances in *P. ginseng* are heterogenous triterpene saponin glycosides or ginsenosides. The species includes Asian ginseng (*P. ginseng*), American ginseng (*P. quinquefolius*), and Japanese ginseng (*P. japonicus*). Another species is Siberian ginseng (*Eleutherococcus senticosus*), which is the root of an unrelated species and does not contain the same substances as panax and technically is not ginseng but has some similar effects. Ginseng, or *ren shen* in Mandarin, means root of man. It is so-called because the root of the plant has the shape of the human body. The word ginseng is derived from the Greek word for panacea.

I. Benefits

Ginseng is felt to be beneficial to patients suffering from heart failure. Red ginseng, digoxin, and digoxin plus red

ginseng were evaluated in patients with heart failure in an open trial that showed hemodynamic improvement with the combination. Although red ginseng was used in the study, it is the same as white ginseng and refers to a different method of ginseng preparation. A mixture of ginseng and Chinese herbs was shown in a double-blind, placebo-controlled trial of coronary artery disease patients to improve cardiac index and stroke volume index. A similar trial of panax plus captopril was compared with captopril in patients with left ventricular diastolic dysfunction. This is a condition which is extremely difficult to treat because there is no beneficial medical drug or surgical therapy available. The combination of panax and captopril improved diastolic relaxation. Because of this outcome, further investigations are warranted.

Red ginseng was observed to relieve hypertension by decreasing systolic blood pressure significantly after 8 weeks of administration. Confusion has arisen because of the reported occurrence of an elevation in blood pressure in some individuals who use ginseng. This increased blood pressure has occurred in individuals who abuse ginseng intake, and it also has been associated with the use of Siberian ginseng, albeit rarely. As specified above, Siberian ginseng is different and must not be confused with *Panax ginseng*.

There are antioxidant effects with ginseng. It appears to scavenge free radicals, but further studies are needed to confirm this.

2. Adverse Effects and Interactions

Hypertension has been observed with overuse of ginseng and with the use of Siberian ginseng. Mild antihypertensive effects have been noted in small clinical trials. Mania has been reported in a patient taking ginseng and phenelzine. Asian ginseng alone has also been associated with mania, albeit rarely.

G. Feverfew (*Tanacetum parthenium*)

The active substance in feverfew is parthenolide, a sesquiterpene lactone. Its other constituents include flavonoids.

I. Benefits

This herbal remedy inhibits the release of serotonin from platelets and leukocytes and is used mainly for migraine prophylaxis. The mild antiplatelet effect may increase

risk of bleeding in patients administered aspirin, clopidogrel, and nonsteroidal anti-inflammatory agents. Also, interactions with anti-serotonin migraine prophylactic drugs may occur, albeit rarely.

H. Gugulipid (*Commiphora mukul*)

Gugulipid is a naturally occurring resin produced by a tree in India.

I. Benefits

The resin in gugulipid has lipid-lowering effects. In a randomized study, 125 patients were administered gugulipid and 108 were administered clofibrate. This resulted in an 11% decrease in blood cholesterol and a 17% decrease in blood triglyceride with gugulipid and 10 and 22%, respectively, with clofibrate. In another study, gugulipid decreased LDL cholesterol by 15% and the total cholesterol ratio by 11% compared with no change in blood level in the placebo group.

This resin appears to have a low adverse effect profile and is used in India. Further testing is required in RCTs to establish these modest beneficial effects that can be useful in combination therapy with the powerful statins, which do not produce goal levels in more than 20% of individuals treated for dyslipidemia.

I. Hawthorn (*Crataegus* Species)

I. Benefits

Hawthorn extracts from the leaves, berries, and flowers of this spiny shrub native to Europe and North America are one of the safer recognized herbal remedies. European physicians used the berries as a cardiotonic in the late 19th century, and it is not surprising that it is a recognized treatment for heart failure in Western Europe. German studies have confirmed that hawthorn improved shortness of breath in patients with heart failure.

Its active constituents are flavonoids and oligomeric procyanthins. These act as antioxidants with an inotropic action which resembles that of digoxin, and are vasodilatory, anti-hyperlipidemic, and increase hepatic LDL receptor activity. A moderate degree of angiotensin-converting enzyme (ACE) inhibition has been reported (see the chapter Angiotensin-Converting Enzyme Inhibitors/Angiotensin Receptor Blockers).

Hawthorn is a cardiotonic agent used by patients mainly for heart failure. Clinical trials indicate that hawthorn decreases symptoms of heart failure and appears to

improve cardiac performance. In an open trial of more than 1000 patients ejection fraction increased and arrhythmias decreased, but in a recent study arrhythmias were aggravated. This herbal medicine appears to have some beneficial effects in patients with mild heart failure (New York Heart Association class II). Improvement in exercise tolerance and decrease in shortness of breath have also been noted. The RCTs, however, have been of short duration; less than 8 weeks. A recent RCT compared a twice-daily regimen of 450 mg or 900 mg of standardized hawthorn extracts with diuretic treatment in patients with stable class III heart failure. After 16 weeks the 1800-mg hawthorn treated group showed a significant increase in maximal workload tolerated and a statistically significant reduction in subjective symptoms. The effect of hawthorn on cardiovascular mortality in patients with class II and III heart failure is under investigation in the Survival and Prognosis Investigation of Crataegus Extract trial.

2. Adverse Effects and Interactions

Side effects of hawthorn are rare, and in one RCT they occurred more often in the placebo group. Because hawthorn has inotropic effects that increase myocardial contractility, it should not be used concurrently with digoxin, even though the claim that hawthorn potentiates digoxin has not been substantiated. No drug interactions have been reported, and this is reassuring.

J. Horse Chestnut Seed (*Aesculus hippocastanum*)

The active substance in horse chestnut seed is aescin.

I. Benefits

In Germany, horse chestnut seed extract has been approved for the management of chronic venous insufficiency of the lower limbs which causes swelling and fluid retention in the legs. Placebo-controlled trials reported lower limb extremity volume and circumference as well as decreased leg pain and itching.

2. Adverse Effects

Nausea and headache were the most common adverse effects. One reported case of hepatitis was seen, and with mixed preparations a lupus-like syndrome has been observed.

K. Hellebore (*Veratrum*)

I. Benefits and Adverse Effects

The veratrum alkaloids are known to be mild antihypertensive substances, but their use was discontinued because of a high incidence of nausea and vomiting. These products may also cause arrhythmias and may interact with digoxin. Bradycardia and hypotension have also been reported in individuals who accidentally ingested hellebore they mistook for gentian used to produce gentian wine.

L. Kava (*Piper methysticum*)

Kava has been used extensively in the South Pacific since ancient times and is incorporated in a beverage called Sakau. Kava, a member of the black pepper family, is a popular herb in the United States. Its active constituents are kava pyrones, which appear to cause modest inhibition of cyclooxygenase and thromboxane synthase.

I. Benefits and Adverse Effects

There are no cardiovascular claims, but in a small study HDL cholesterol appeared to be higher in users of this herb. Kava certainly causes some degree of relaxation and unlike tranquilizers, it does not affect mental alertness or cause the hangover produced by alcohol. It may, however, cause pulmonary hypertension and hepatitis. Interactions occur with tranquilizers including alprazolam, and coma may be induced in patients on other benzodiazepines.

M. L-Arginine

I. Benefits and Adverse Effects

L-Arginine is metabolized to nitric oxide, a known vasodilator. A Mayo Clinic trial indicated that L-arginine 9 g daily improved coronary blood flow response to acetylcholine by 150% and caused a modest decrease in chest pain and angina in patients with coronary artery disease. Further studies are required. There has been a rapid development in the use of L-arginine and the substance is now available in nutritional bars. Foods high in arginine include almonds, walnuts, peanuts, soybeans, gelatin, chocolate, dairy products, and green peas. Individuals with viral infections such as herpes should not take supplemental arginine.

N. Linoleic Acid

I. Benefits and Adverse Effects

Conjugated linoleic acid has been advertised as a compound that can cause weight loss, combat atherosclerosis, and assist with the control of type 2 diabetes. These claims are not justified by clinical trials.

O. Licorice

I. Benefits and Adverse Effects

This substance is used mainly as a sweetening agent. No particular cardiovascular benefits from licorice have been advocated. Cardiovascular adverse effects have been noted to include significant hypertension, hypertensive encephalopathy, edema, and heart failure. Damage to the heart muscle causing dilated cardiomyopathy has also been reported.

P. St. John's Wort

I. Benefits and Adverse Effects

No particular cardiovascular benefits have been claimed, but significant adverse effects have been documented and well-recognized for St. John's wort. Severe elevation of blood pressure and hypertensive crisis have been noted. An elevation of systolic blood pressure systolic to 210 and diastolic blood pressure to 140 mmHg were reported in patients who drank red wine and ate aged cheese the day before. St. John's wort has monoamine oxidase inhibiting properties and tyramine-rich foods should be avoided.

Interactions with St. John's wort are common. The herb induces an increase in cytochrome P3A4, a hepatic enzyme that is active in drug metabolism, and increases the rate metabolism of warfarin, cyclosporine, and a number of anesthetic agents. The blood-thinning, anticoagulant effect of warfarin is decreased and interactions occur with statins and cyclosporine. Acute rejection in two heart transplant patients occurred because St. John's wort reduces blood levels of cyclosporine and decreases digoxin blood levels more than 25%.

Q. Yohimbine (*Pausinystalia yohimbe*)

I. Benefits and Adverse Effects

No cardiovascular benefits have been advocated, but cardiovascular adverse effects do occur. The active substance of yohimbine is a competitive alpha-2-antagonist that increases central sympathetic outflow and raises blood

pressure, heart rate, and norepinephrine levels. Hypertensive patients may observe seriously elevated blood pressure and arrhythmias. This compound antagonizes the effects of centrally acting antihypertensive agents such as clonidine, guanabenz, and methyldopa.

R. Other Natural Products

Belladonna is a source of atropine and may cause tachycardia. Beta-carotene (provitamin A) has been shown to have no significant beneficial cardiovascular effects in large studies. The Physician's Health Study randomized 22,071 males in the United States to aspirin 325 mg daily or beta-carotene 50 mg every other day. After 12 years there were no cardiovascular benefits from beta-carotene administration.

a. Grapefruit

The main constituent of grapefruit juice, naringenin is metabolized by the CYP450 metabolic pathway and interacts with drugs that use the pathway. These agents include calcium antagonists such as amlodipine, fluoxetine, sildenafil (Viagra), cyclosporine, statins (except pravastatin and rosuvastatin), metoprolol, and propranolol.

Flavonoids are a class of natural polyphenolics found in plants, vegetables, fruits, and beverages of plant origin, such as tea and wine.

Zitron *et al.* have found numerous different flavonoid compounds in grapefruit juice that block cardiac HERG channels. These investigators studied pink grapefruit which has a high concentration of naringenin. They showed that naringenin caused significant prolongation of the QTc interval, and the effect is more potent than other flavonoids tested. The investigators claim that "we are the first to show direct effects on the ECG by dietary compounds. Furthermore, we have demonstrated for the first time that flavonoids act as specific antagonists of cardiac potassium channels."

b. Purple Grape Juice

Purple grape juice has been shown to decrease platelet aggregation, increase platelet-derived nitric oxide release, and decrease superoxide production. In a small study of 20 healthy subjects whose average age was 30 years, a 14-day consumption of grape juice resulted in suppression of platelet-mediated clot formation (thrombosis). This effect is independent of alcohol consumption. The major polyphenolic compounds isolated from purple grape juice

include cinnamic acids, anthocyanins, flavonols, (quercetin), and polyflavan-3-ols.

c. Others

Black tea consumption has been shown to reverse endothelial or vasomotor dysfunction in patients with cardiac disease. This modest beneficial effect is believed to be due to the antioxidant effects of flavonoids.

Several natural products increase digoxin blood levels or potentiate its actions. These include hawthorn, oleander, black hellebore, adonis, black Indian hemp, lily of the valley, squill, strophanthus, milkweed, kushen, and Siberian ginseng.

IV. SUBSTANCES USED BY ATHLETES

Many athletes may indicate that they are not taking medications and fail to recognize that herbal preparations and dietary supplements may contain prohibited substances that are cardiovascular stimulants. Substances commonly used by athletes include ephedra alkaloids (e.g., Ma Hung or ephedrine) and guarana (caffeine). Adverse effects include arrhythmias and catecholamine cardiomyopathy.

Anabolic steroids containing androstenedione or androstenediol may cause left ventricular hypertrophy. These two compounds are precursors to testosterone and estrogen. Cases of sudden death have been reported in athletes using anabolic steroids. A catecholamine cardiomyopathy may be a dangerous complication. Dickerman *et al.* reported that 100% of athletes using anabolic steroids had a left ventricle wall thickness greater than 11 mm. These substances may cause hypertension and dyslipidemia.

Creatine has been shown to enhance muscle growth and increase strength without the side effects of the anabolic steroids. This agent increases muscle mass in active athletes who engage in intense isometric training, but not in those who trained aerobically. No major side effects have been observed. Weight gain may occur during the first two weeks of therapy.

Gamma butyrolactone has been eliminated from products in the United States because of an FDA warning in 1999 to manufacturers. This warning was made because there was a report of more than 55 cases of adverse reactions including coma that required artificial ventilatory support. The coma occurred in a professional basketball player who ingested the substance to aid in sleep and help muscle growth. Gamma butyrolactone is metabolized into

gamma-hydroxybutyrate, which is known to cause seizures and coma.

BIBLIOGRAPHY

- Appeldoorn, C. C. M., Bonnefoy, A., Lutters, B. C. H. et al. Gallic acid antagonizes P-selectin-mediated platelet-leukocyte interactions: Implications for the French paradox. *Circulation*, 111:106–112, 2005.
- Bove, A. A. Dietary supplements in athletes. *J. Am. Coll. Cardiol. ACC Curr. J. Rev.*, January/February, 18–20, 2002.
- DeSmet, P. A. G. M. Herbal remedies. Review article. *N. Engl. J. Med.*, 347:2046–56, 2002.
- Dickerman, R. D., Schaller, F., and McConathy, W. J. Left ventricular wall thickening does occur in elite power athletes with or without anabolic steroid use. *Cardiology*, 90:145–148, 1998.
- Freedman, J. E., Parker, C., Li, L. et al. *J. Am. Coll. Cardiol. Acc Curr. J. Rev.*, January/February, 28, 2002.
- Khan, M. Gabriel Drug interactions. In *Cardiac Drug Therapy*. 6ed, W.B. Saunders, 2003.
- Moss, A. J., Schwartz, P. J. et al. 25th Anniversary of the international long-QT syndrome registry: An ongoing quest to uncover the secrets of long-QT syndrome. *Circulation*, 111:1199–1201, 2005.
- Sacks, F. M. et al. Dietary phytoestrogens to prevent cardiovascular disease: Early promise unfulfilled. *Circulation*, 111:385–387, 2005.
- Szmitko, P. E., Verma, S. et al. Red wine and your heart. *Circulation*, 111:e10–e11, 2005.
- Valli, G., and Giardina, E-G. V. Benefits, adverse effects and drug interactions of herbal therapies with cardiovascular effects. *J. Am. Coll. Cardiol.*, 39:1083–95, 2002.
- Zitron, E., Scholz, E., Owen, R. W. et al. QTc prolongation by grapefruit juice and its potential pharmacological basis: HERG channel blockade by flavonoids. *Circulation*, 111:835–838, 2005.

HIV and the Heart

I. Incidence

II. Cardiac Complications of Aids

GLOSSARY

arrhythmia general term for an irregularity or rapidity of the heartbeat, an abnormal heart rhythm.

cardiomyopathy heart muscle disease.

ejection fraction the fraction of blood ejected from the heart into the arteries, normally this ranges from 60–75%; a low ejection fraction is less than 40%; often used as a marker of left ventricular contractility.

heart failure failure of the heart to pump sufficient blood from the chambers into the aorta; inadequate supply of blood reaches organs and tissues.

infective endocarditis infection of the endocardial lining of heart valves with microorganisms.

myocarditis damage to the heart muscle caused by microorganisms or autoimmune and other undefined processes.

pericardial effusion excess fluid within the pericardial sac.

pericardium a membranous sac surrounding the heart consisting of an outer fibrous layer and an inner serosal layer which are separated by a thin film of pericardial fluid in the pericardial sac.

syncope transient loss of consciousness by lack of blood supply to the brain; fainting describes a simple syncopal attack.

ventricular dysfunction poor contractility of the ventricle usually causing a decrease in ejection fraction.

SIGNIFICANT CARDIAC DISEASE OCCURS IN patients with the human immunodeficiency virus (HIV), and it is believed that in the next decade acquired immunodeficiency syndrome (AIDS) will be one of the leading causes of acquired heart disease.

I. INCIDENCE

Significant heart disease occurs in approximately 5% of people with AIDS. In an autopsy series 18% of 440 patients had cardiac involvement. In 1998, the Joint United Nations program on AIDS estimated that

approximately 34 million people were living with HIV infection worldwide. In the United States new infection has decreased significantly over the past four years and deaths associated with HIV infection decreased approximately 25% from 1997 to 1999 because of improved antiretroviral therapies and the management of opportunistic infections. Other workers estimate that approximately 60 million adults and 10 million children are currently infected with the virus worldwide. These patients are expected to live longer because of improved therapies and control of opportunistic infections. This will result in what may be an epidemic of HIV-related heart disease. The mean annual incidence is estimated at approximately 16 cases of cardiac disease per 1000 HIV-infected patients. HIV infections were mainly observed in homosexual males during the early years of the HIV epidemic; new cases continue to occur in IV drug users and heterosexual partners of infected persons.

II. CARDIAC COMPLICATIONS OF AIDS

A. Pericardial Effusion

Pericardial disease is the most common cardiac complication of HIV infection and it causes approximately 60% of all cardiac pathology. Figure 1 shows HIV cardiac complications. Approximately 5% of individuals infected with HIV show echocardiographic evidence of pericardial effusions. In more than 75% of cases pericardial effusions are small and usually asymptomatic, but they indicate advanced disease and poor prognosis. Pericardial effusions may compress the heart, cause cardiac tamponade, and prevent adequate filling which results in a marked fall in blood pressure, cardiogenic shock, and death. In approximately 30% of patients the effusion resolves spontaneously.

The disease of the pericardium may be caused by the following types of infections.

1. Viruses: cytomegalovirus (CMV), HIV, herpes simplex
2. Bacterial: *Staphylococcus aureus*, *Streptococcus pneumoniae*, *Klebsiella pneumoniae*, mycobacteria
3. Fungi: *Cryptococcus neoformans*

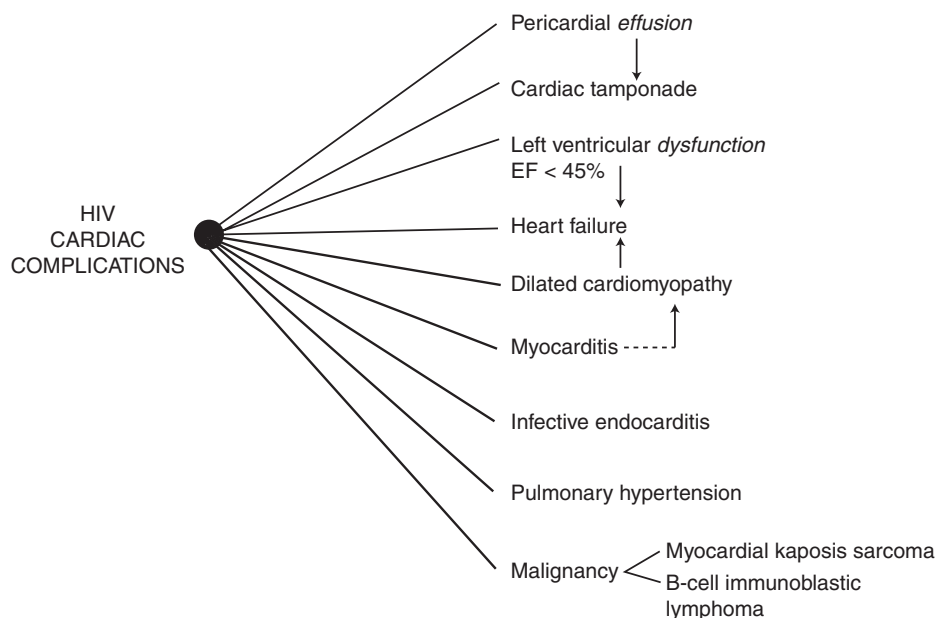

FIGURE 1 HIV cardiac complications.

4. Neoplastic involvement: malignant lymphoma; Kaposi's sarcoma may involve both the pericardium and epicardial fat

The first case of cardiac involvement was reported in 1983 in a 24-year-old Haitian woman with extensive Kaposi's sarcoma that involved the entire anterior wall of the heart muscle.

B. Myocarditis and Left ventricular Systolic Dysfunction

Weakness of the muscle of the left ventricle with left ventricular systolic dysfunction is common and results in dilated cardiomyopathy and heart failure (see the chapter Cardiomyopathy). A five-year prospective clinical and echocardiographic study of asymptomatic HIV-positive patients with CD4 counts greater than 400 defined the incidence of dilated cardiomyopathy as 16 cases per thousand patients. The incidence rate is higher in those patients with CD4 counts less than 100 cells/ml⁴.

From 1998 to 2000, of the estimated 70 million people worldwide infected with HIV with an incidence of heart failure of 10% over 2 years, there would be approximately 7 million cases of heart failure during a 2-year interval due to AIDS. Left ventricular dysfunction occurs in about 6% of infected children.

The pathogenesis of myocarditis may be a result of primary infection with HIV or organisms such as CMV, Coxsackie virus, and a host of other microorganisms, or the reactivation of latent infections.

C. Other Complications

These include infective endocarditis that is more common in IV drug users with the infecting organisms *S. aureus* and salmonella. In the later stages of HIV malignancy occurs. This takes the form of Kaposi's sarcoma which is linked with human herpesvirus 8 and mainly affects HIV homosexuals (~35%). Pulmonary hypertension and stroke may occur. Unexplained syncope or cardiac tamponade in younger individuals should alert the search for HIV infection.

BIBLIOGRAPHY

- Autran, B. R., Gorin, I., Leibowitch, M. et al. AIDS in the Haitian woman with cardiac Kaposi's sarcoma and Whipple's disease. *Lancet*, 1:767-68, 1983.
- Barbaro, G., Di Lorenzo, B. G., Grisorio, B. et al. Incidence of dilated cardiomyopathy and detection of HIV in myocardial cells of HIV positive patients. *N. Engl. J. Med.*, 339:1093, 1988.
- Barbaro, G. et al. Cardiovascular manifestations of HIV infection. *Circulation*, 106:1420-1425, 2002.
- Gisselwquist, D. et al. HIV transmission through health care in sub-Saharan Africa. *Lancet*, 364:2004.
- Heidenreich, P. A., Eisenberg, M. J., Kee, L. L. et al. Pericardial effusion in AIDS: Incidence and survival. *Circulation*, 92:3229, 1995.
- Lipshultz, S. E., Easley, K. A., Orav, E. J. et al. Cardiac dysfunction and mortality in HIV-infected children: The prospective P2C2 HIV Multicenter study. *Circulation*, 102:1542-1548, 2000.
- UNAIDS: Report on the Global HIV/AIDS Epidemic. Geneva, Switzerland. UNAIDS, June 1998.

Homocysteine and Cardiovascular Disease

- I. Homocysteine Metabolism
- II. Homocysteine and Vascular Disease
- III. Clinical Studies
- IV. Conditions Causing Hyperhomocystinemia
- V. Screening
- VI. Management of Hyperhomocystinemia
- VII. Benefits of Decreasing Homocysteine Levels
- VIII. Clinical Studies

GLOSSARY

- atheroma** same as atherosclerosis, raised plaques filled with cholesterol, calcium, and other substances on the inner wall of arteries that obstruct the lumen and the flow of blood; the plaque of atheroma hardens the artery, hence the term atherosclerosis (sclerosis = hardening).
- endothelial** pertaining to the innermost part of the intima that comes in contact with circulating blood.
- myocardial infarction** death of an area of heart muscle due to blockage of a coronary artery by blood clot and atheroma; medical term for heart attack or coronary thrombosis.

HYPERHOMOCYSTEINEMIA HAS BEEN IDENTIFIED AS a possible risk factor in the development of cardiac, cerebral, and peripheral vascular disease as well as acute thrombotic events. Unfortunately this assumption is based mainly on the results of case control studies and prospective studies have not been as compelling. In addition, there is growing belief that atheromatous disease of arteries itself may elevate homocysteine levels, and that this controversial risk factor is only a silent bystander and should be considered a marker rather than a true risk factor.

I. HOMOCYSTEINE METABOLISM

Homocysteine, a sulfa-containing amino acid, is an intermediate formed during the metabolism of the essential amino acid methionine. In this metabolic pathway,

methionine is demethylated to yield adenosine and homocysteine. In a reaction requiring the vitamin B6-dependent enzyme cystathionine, beta-synthase homocysteine becomes irreversibly transsulfurated to cysteine. In addition, homocysteine can be remethylated back to methionine in a pathway that utilizes vitamin B12-dependent methionine synthase.

II. HOMOCYSTEINE AND VASCULAR DISEASE

Epidemiologic studies suggest that hyperhomocystinemia may be an independent risk factor for developing atherothrombotic vascular disease. Although the mechanism for accelerated atherosclerosis is unclear, proposed mechanisms for increased risk of coronary artery disease include endothelial dysfunction and toxicity, induction of vascular smooth muscle cell proliferation, impairment of nitric oxide, increased LDL oxidation, and enhanced thrombosis.

Hyperhomocystinemia has not been shown in animals or in humans to cause atheroma formation, which leads to obstructive lesions in coronary arteries, cerebral arteries, the aorta, or vessels leading to the legs. Pathologic lesions in arteries of experimental animals indicate disease diffusely involves the outer layer, the adventitia and the media with little involvement of the intima and without the formation of segmental atheromatous obstructive lesions. The lesion has a more arteriosclerotic nature rather than atherosclerotic (see the chapters Arteriosclerosis and Atherosclerosis/Atherothrombosis).

III. CLINICAL STUDIES

A. Willems et al.

Study question: The mechanism responsible for an increased risk for coronary artery disease is unclear; it is generally assumed that hyperhomocystinemia causes endothelial dysfunction. It is unknown whether plasma homocysteine levels improve coronary endothelial function

in patients with hyperhomocystinemia and symptomatic coronary heart disease. This study evaluated the effect of the administration of folic acid and vitamin B12 on coronary endothelial function.

Methods: There were 15 patients scheduled for balloon coronary angioplasty with plasma homocysteine levels greater than 16 $\mu\text{mol/L}$ who were randomized for six months of treatment with folic acid 5 mg, cobalamin 400 μg daily, or placebo. Coronary endothelial function was evaluated in a noncoronary vessel using acetylcholine infusion.

Results: In the folic-acid-treated group coronary blood flow increased 96% after acetylcholine infusion when compared with a decrease of 16% of the coronary blood flow in the placebo-treated group ($p=0.005$).

Conclusions: This study suggests that coronary endothelial function improves after treatment with folic acid and cobalamin. It is unclear, however if the salutary effect observed bears any relation to atheroma formation and its progression to thrombotic events.

B. Schnyder et al.

Study question: This study was to evaluate a possible relationship between homocysteine levels and late outcome after successful percutaneous coronary intervention (PCI).

Methods: Included were 549 patients after successful PCI of at least one coronary stenosis with cardiac death, nonfatal myocardial infarction (MI), target lesion revascularization (TLR), and a composite of major adverse cardiac events (MACE). Their homocysteine levels were assessed.

Results: At 58 weeks' follow up there were 6 cardiac deaths, 14 with new MI; 71 required repeat TLR. There was a graded relationship between homocysteine levels and freedom from MACE ($p=0.01$). Homocysteine levels were associated with cardiac death ($14.9 \pm 1.7 \mu\text{mol/L}$ vs. $9.6 \pm 4.3 \mu\text{mol/L}$; $p < 0.005$), TLR ($10.7 \pm 4.4 \mu\text{mol/L}$ vs. $9.5 \pm 4.3 \mu\text{mol/L}$; $p < 0.05$), and MACE ($11.0 \pm 4.4 \mu\text{mol/L}$ vs. $9.4 \pm 4.3 \mu\text{mol/L}$; $p < 0.005$). These findings were unchanged after adjustment for potential confounders.

Conclusions: Homocysteine levels are an independent predictor of mortality, nonfatal MRI, TLR, and overall adverse late outcome after successful PCI. The study results appear compelling, but there is growing belief that atherosclerotic disease itself can cause elevated homocysteine levels. In this prospective study, however, the association between the homocysteine levels and outcome after PCI was independent, although with traditional risk factors. Thus, elevated homocysteine levels appear to be just a marker rather than a risk factor for coronary artery disease. There is little doubt that this statement does not apply to the problem of restenosis.

IV. CONDITIONS CAUSING HYPERHOMOCYSTEINEMIA

A. Medical Conditions

Homocysteine levels have been noted to increase soon after an acute MI or stroke along with occurrence of the conditions listed below.

- Renal failure
- Hypothyroidism
- Some forms of cancer
- Inflammatory bowel disease
- Rheumatoid disease
- Psoriasis
- The post-transplant state
- Vitamin B12 deficiency
- Folate deficiency
- MTHFR gene deficiency.

A polymorphism in the MTHFR gene results in a thermolabile enzyme associated with elevated homocysteine levels. The prevalence of this mutation is low in Asian-Indians and Africans ranging from 0 to 2% vs. 10 to 20% in other populations.

B. Medications

Several medications can cause elevation of homocysteine levels. These include drugs that interfere with the:

- functional vitamin B6: niacin, theophylline, isoniazid
- functional vitamin B12: cholestyramine, colestipol, metformin
- function of folate: anticonvulsants, methotrexate.

C. Lifestyle Behaviors

Lifestyle behaviors that increase homocysteine levels are heavy alcohol consumption, excessive coffee consumption, cigarette smoking, and physical inactivity.

V. SCREENING

Screening recommendations for hyperhomocystinemia remain controversial and diverse. The lack of evidence substantiating clinical benefit of treatment of hyperhomocystinemia as well as unnecessary laboratory costs are potent arguments against recommending widespread screening.

A. American Heart Association Recommendation

The American Heart Association does not recommend population screening. They do suggest, however, that screening may be useful in certain high-risk patients with conditions known to be associated with hyperhomocystinemia.

B. European International Task Force Recommendation

The European International Task Force for the Prevention of Coronary Heart Disease recommends the measurement of homocysteine in patients with premature coronary artery disease or stroke in the absence of the well-established vascular risk factors. This appears to be a reasonable approach in young individuals with stroke prior to age 45 caused by cerebral thrombosis (intracerebral hemorrhage and subarachnoid hemorrhage should be excluded) and in patients with acute myocardial infarction prior to age 35. These ages are selected by the author to clarify the above recommendations, because at this age these conditions are rare as strokes usually occur after age 55 in men and women and heart attacks commonly occur in men after age 40 and women after age 60.

C. Canadian Task Force Recommendation

The Canadian Task Force on Preventive Health Care indicates that there is insufficient evidence to recommend screening for homocysteine levels in any patient population.

D. Normal and Abnormal Homocysteine Levels

Normal homocysteine blood levels that range from 5 to 15, 16 to 30, 30 to 100 and greater than 100 $\mu\text{mol/L}$ are described as mild, intermediate, and severe elevations, respectively. Women appear to have levels 1 $\mu\text{mol/L}$ less than men; values increase with age in both sexes.

VI. MANAGEMENT OF HYPERHOMOCYSTEINEMIA

A. Folic Acid Intake

A diet rich in folic acid and vitamins B12 and B6 may reduce levels by approximately 10%. Folic acid tablets,

0.5–5 mg taken daily, reduce homocysteine levels 25–30%. Multivitamins containing 400 μg of folic acid can cause a similar reduction. The addition of vitamin B12 to folic acid supplementation may reduce levels a further 7%. Also vitamin B6 intake can cause some reduction in homocysteine levels.

VII. BENEFITS OF DECREASING HOMOCYSTEINE LEVELS

Unfortunately no benefit to cardiovascular mortality or morbidity has been observed in randomized clinical trials, except in patients who had successful coronary angioplasty. A modest decreased rate of coronary restenosis following coronary angioplasty has been noted after lowering of plasma homocysteine levels, but this requires confirmation that is unlikely to be forthcoming.

In a sound crossover study, however, optimization of dietary folate or low-dose folic acid supplements lowered homocysteine levels, but they did not enhance endothelial function in healthy adults, irrespective of the MTHFR C 677T genotype.

VIII. CLINICAL STUDIES

In a meta-analysis of predominantly case control studies, 14 of 17 papers supported the link between elevated homocysteine and an increase risk for vascular disease. Although these data appear impressive, there are several limitations to case control studies and the data from prospective studies are not convincing.

Because homocysteine levels increase after acute myocardial infarction and stroke, it makes case control studies less useful. The overabundance of hypothesized clarifications of homocysteine-induced cardiovascular disease reflects the lack of a proven unified mechanism of vascular injury.

Although homocysteine levels can be successfully reduced by folic acid administration, no benefit toward cardiovascular morbidity or mortality has been observed in randomized trials.

A. The Recent FACIT Trial; Lange et al.

A recent randomized clinical trial showed that folate therapy increases restenosis rates in intracoronary stent recipients. The folate therapy after coronary intervention

(FACIT) trial enrolled 636 patients who underwent successful coronary stenting and were randomized to receive supplemental treatment with folate and vitamins B₆ and B₁₂. The trial investigated whether folate therapy, which is known to reduce high blood levels of homocysteine, can limit in-stent restenosis. After 6 months of follow up, folate therapy caused a significantly smaller minimum lumen diameter as well as higher restenosis and major adverse cardiac event rates; folate therapy should therefore be avoided following coronary stent implantation. Contrary to previous findings, the administration of folate, vitamin B₆, and vitamin B₁₂ after coronary stenting may increase the risk of in-stent restenosis and the need for target-vessel revascularization.

B. Toole et al.: The Vitamin Intervention for Stroke Prevention (VISP) Randomized Controlled Trial

Objective: To determine whether high doses of folic acid, pyridoxine, and vitamin B₁₂ administered to decrease homocysteine levels reduce the risk of recurrent stroke compared with low doses of these vitamins.

Methods: In this study 3680 adults with disabling cerebral infarctions were randomized to high- and low-dose formulations of these vitamins.

Results: At the end of two years a moderate reduction of total homocysteine had no effect on vascular outcomes.

BIBLIOGRAPHY

Brattström, L., Wilcken, D. E. L., Öhrvik, J. et al. Common methylenetetrahydrofolate reductase gene mutation leads to

- hyperhomocysteinemia but not to vascular disease: The result of a meta-analysis. *Circulation*, 98:2520–2526, Dec. 1998.
- Fruchart, J. C., Nierman, M. C., Stroes, E. S. G., Kastelein, J. J. P., Duriez, P. et al. New risk factors for atherosclerosis and patient risk assessment. *Circulation*, 109:III-15–III-19, Jun. 2004.
- Hoogeveen, E. K., Kostense, P. J., Jakobs, C., Dekker, J. M., Nijpels, G., Heine, R. J., Bouter, L. M., Stehouwer, C. D. A. et al. Hyperhomocysteinemia increases risk of death, especially in type II Diabetes: 5-Year follow-up of the Hoorn study. *Circulation*, 101:1506–1511, Apr. 2000.
- Lange, H., Suryapranata, H., De Luca, G. et al. Folate therapy and in-stent restenosis after coronary stenting. *N. Engl. J. Med.*, 350: 2673–2681, 2004.
- Pullin, C. H., Ashfield-Watt, P. A. L., Burr, M. L. et al. Optimization of dietary folate or low-dose folic acid supplements lower homocysteine but do not enhance endothelial function in healthy adults, irrespective of the methylenetetrahydrofolate reductase (C677T) genotype. *J. Am. Coll. Cardiol.*, 58:1799–805, 2001.
- Ridker, P. M., Brown, N. J., Vaughan, D. E., Harrison, D. G., Mehta, J. L. et al. Established and emerging plasma biomarkers in the prediction of first atherothrombotic events. *Circulation*, 109:IV-6–IV-19, Jun. 2004.
- Rodriguez, J., and Robinson, K. Homocysteine: Do we know how to screen and treat? *J. Am. Coll. Cardiol. ACC Curr. J. Rev.*, May/June, 31–34, 2001.
- Schnyder, G., Flammer, Y., Roffi, M. et al. Plasma homocysteine levels and late outcome after coronary angioplasty. *J. Am. Coll. Cardiol.*, 40:1769–76, 2002.
- Schnyder, G., Roffi, M., Pin, R. et al. Decreased rate of coronary restenosis after lowering of plasma homocysteine levels. *N. Engl. J. Med.*, 345:1593–600, 2001.
- Toole, J. F., Malinow, M. R., Lloyd, E. C. et al. Lowering homocysteine in patients with ischemic stroke to prevent recurrent stroke, myocardial infarction, and death. The vitamin intervention for stroke prevention (VISP) randomized controlled trial. *JAMA*, 291: 565–575, 2004.
- Willems, F. F., Aengrvaeren, W. R. M., and Boers, G. H. J. Coronary endothelial function in hyperhomocysteinemia: Improvement after treatment with folic acid and cobalamin in patients with coronary artery disease. *J. Am. Coll. Cardiol.*, 40:766–72, 2002.

Hypertension

- I. Measurement of Blood Pressure
- II. How High Is High?
- III. Causes of Hypertension
- IV. Pathogenesis of Primary Essential Hypertension
- V. Complications
- VI. Symptoms
- VII. Investigations
- VIII. Nondrug Treatment
- IX. Drug Treatment

GLOSSARY

afterload arterial impedance, restriction to blood flow delivered from the left ventricle; force against which the myocardium contracts in systole; a major determinant of ventricular wall stress.

atherosclerosis same as atheroma, raised plaques filled with cholesterol, calcium, and other substances on the inner wall of arteries that obstruct the lumen and the flow of blood; the plaque of atheroma hardens the artery, hence, the term atherosclerosis (sclerosis = hardening).

heart failure a failure of the heart to pump sufficient blood from the chambers into the aorta, inadequate supply of blood reaches organs and tissues.

hypertrophy increase in thickness of muscle.

myocardial infarction death of an area of heart muscle due to blockage of a coronary artery by blood clot and atheroma; medical term for a heart attack or coronary thrombosis.

renoprotection protection of the nephrons of the kidney from damage, destruction, and amelioration of albuminuria.

HYPERTENSION, COMMONLY KNOWN AS HIGH blood pressure, is a problem suffered by more than 60 million people in the United States from the age of 65 to 75. The incidence of hypertension is higher in African-Americans. There are approximately 1 billion individuals with hypertension worldwide.

The complications of high blood pressure often lead to early death or serious physical handicaps. There are

generally very few symptoms associated with high blood pressure. Dizziness and headaches may occur in some patients but generally health complaints may not surface for 5–20 years, thus the term “the silent killer.”

Blood pressure is the pressure exerted by the blood against the inner walls of the blood vessels, especially the arteries (see the chapter on Blood Pressure). The blood pressure changes from minute to minute and is influenced by many factors such as activity, age, health, emotional tension, and so on. With each heartbeat, about 70 ml of blood is ejected from the heart and propelled through approximately 100,000 km of blood vessels. Constriction of the blood vessels (arteries) causes high blood pressure and greatly increases the work of the heart. Arteries are traumatized by high blood pressure and this increases the development of hardening of the arteries owing to plaques of atheroma (atherosclerosis). The heart may enlarge, arteries may become gradually blocked, and circulation to the heart muscle, the brain, and other organs may slowly become impaired until one day there will be an emergency situation such as a sudden heart attack or stroke. It is true that hypertension maims and kills millions through preventable complications.

Clinical trials during the past 20 years have revolutionized the treatment of hypertension with and without drugs. Many familiar (old) drugs have been rendered obsolete because of newer, safer, and more effective alternatives.

Safe and effective treatment is available either with nondrug programs or with a suitably selected drug. Drug selection is important and is discussed in some detail in the following sections.

I. MEASUREMENT OF BLOOD PRESSURE

The instrument used to measure blood pressure is called a sphygmomanometer. It measures the air pressure needed to raise a column of mercury (Hg). The instrument consists of an inflatable cuff connected to a small bulb pump and a pressure gauge. By means of the inflatable cuff, which encircles the limb (usually the upper arm), air pressure

within the cuff is balanced against the pressure in the artery (usually the brachial artery at the elbow). The pressure is estimated by means of a mercury or aneroid manometer. The mercury manometer is the most accurate pressure gauge. The aneroid gauge is frequently used instead of the mercury manometer because it is more compact and is convenient as a portable instrument. Some electronic instruments may give falsely high diastolic readings, but manufacturers will improve these to meet market demands.

The cuff size of the sphygmomanometer is of great importance. If the cuff is too small for the patient's arm, the blood pressure reading may be falsely high. In this case some moderately obese patients may be falsely classified as hypertensives if a normal cuff is used. A regular cuff may be used for arm circumference of less than 33 cm. A large cuff should be used whenever the mid-upper arm circumference exceeds 33 cm. The cuff must be applied snugly. To measure blood pressure, the cuff is wrapped around the arm about one inch above the elbow crease. Ask your doctor or nurse to show you how to take your own blood pressure. Occasionally both the radial pulse at the wrist and the brachial pulse at the elbow over which the stethoscope is placed are difficult to feel.

The patient should be lying or sitting comfortably. The forearm should rest on a comfortable support such as a table *at near heart level*. If the arm is not well supported, muscle contractions will falsely elevate the blood pressure. Apply the cuff so that the arrow or mark on the cuff is directly in line with the brachial artery (see Fig. 1). The arrow on the edge of the cuff is then approximately one inch above the point of application of the stethoscope.

Feel the radial pulse at the wrist. Close the valve of the instrument and hold the bulb in the right hand between the palm and fingers. Squeeze the bulb rapidly and fully. Continue squeezing the bulb several times to pump air into the cuff. The air pressure will at some point stop the blood flow through the brachial and radial arteries. Rapid inflation avoids trapping of blood in the veins of the forearm. As the cuff is inflated the radial pulse at the wrist will disappear. Keep on pumping so that the manometer pressure is increased by another 20–30 mmHg. Then gradually open the valve, decreasing the pressure slowly at a rate of about 2 mm per second until you can just feel the radial pulse. Note the reading in millimeters of mercury (mmHg). This is the systolic blood pressure by palpation.

To obtain the blood pressure using a stethoscope, if your systolic blood pressure is usually 140 mmHg, pump the cuff up to a pressure on the gauge of 170, then put the stethoscope on the brachial artery (position as indicated in Fig. 1), then slowly release the air. Suddenly thudding

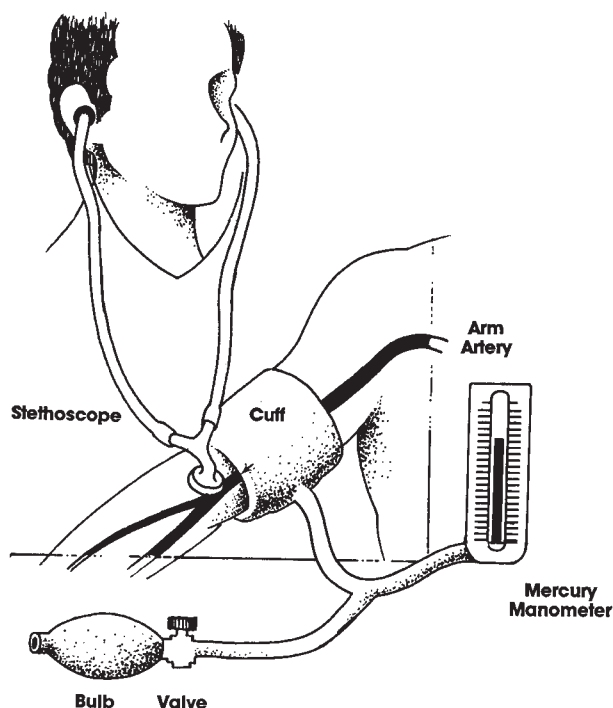

FIGURE 1 Measurement of blood pressure.

sounds are heard, which are impossible to miss if the room is quiet and the stethoscope earpieces are fitting snugly. The sounds are produced by the blood being pushed by each heartbeat through the artery previously blocked by the air pressure. The air pressure recorded by the gauge in mmHg at which you first hear the sounds is the systolic blood pressure. These thudding sounds produced by blood movement and vessel vibrations are called Korotkoff's sounds, as described by Dr. Nicolai Korotkoff in 1910 (see the chapter Blood Pressure). Further decrease the air pressure until all sounds just disappear and take the reading from the gauge as the diastolic blood pressure. Record, for example, as follows: systolic 140, diastolic 80, or 140/80.

It is important to center the arrow on the cuff and place the stethoscope directly over the brachial artery. Your doctor can work out the line of the artery for you. The tendon of the biceps can be felt in the crook of the elbow and the artery is about 1 cm off-center, medial to the biceps tendon, that is, nearer the body. Place the stethoscope in the crook of the elbow just to the inside of the middle of your forearm. It can be helpful to tape the stethoscope's diaphragm to the elbow if you are measuring your own blood pressure. If you wish to repeat the blood pressure reading, you must completely deflate the cuff

and wait 60 seconds; otherwise, congestion of blood in the veins of the arm can cause subsequent diastolic readings to be falsely high.

Occasionally it may be necessary to take blood pressure both while lying down and standing, especially if the patient is on medication. Some antihypertensive drugs cause the blood pressure to drop suddenly when the patient stands, and this is called postural hypotension. In some patients over 65 years of age, markedly hardened vessels may require higher cuff pressures to stop the blood flow through the artery. This results in falsely high systolic pressure readings.

II. HOW HIGH IS HIGH?

The World Health Organization (WHO) and many experts agree that in individuals under age 65, a systolic blood pressure equal to or greater than 140 mmHg and a diastolic blood pressure of 90 mmHg or above is abnormal. Optimal systolic blood pressure is less than 120 mmHg and optimal diastolic blood pressures are less than 80 mmHg. In patients age 65–80 a systolic pressure greater than 165 on three or more readings weeks or months apart is considered hypertension. The Framingham Study and other studies indicate a significant increase in cardiovascular risk in individuals with a blood pressure in the borderline range. An individual is considered to have high blood pressure if several readings exceed 140/90, especially if three consecutive readings are elevated. The risk at any level of hypertension, including borderline hypertension, is greatly increased by smoking or a high blood cholesterol. Mild hypertension is extremely common, and over a 10- to 15-year period increases the risk of stroke, heart attack, and heart failure. Clinical studies have documented that blacks develop organ damage (stroke, heart failure, and damage to the kidneys) much quicker than whites at the same level of hypertension.

Blood pressure changes from minute to minute and is lowest during sleep, dropping as much as 10–30 mmHg. It rises in the morning and usually becomes higher in the afternoon. This makes it necessary to measure the blood pressure several times during the day and to record the time of the measurement. An average of at least three readings is often taken by the doctor. Blood pressure increases to the adult level by age 16. The systolic blood pressure tends to increase slightly after age 30. After age 65, a greater increase often occurs, owing primarily to hardening of the arteries, and a falsely elevated pressure may be recorded.

A. Old convention, 1930–1996

Levels used generally worldwide to indicate hypertension in individuals under age 70, from 1930 to about 1996, were as follows:

- Mild hypertension: diastolic blood pressure is 91–100 or systolic pressure is 140–160
- Moderate hypertension: the diastolic is 100–110 or systolic is greater than 180
- Severe hypertension: the diastolic is 115–130, regardless of the systolic pressure, and very severe if the diastolic is greater than 130 mmHg.

Prior to 1975, doctors believed that it was mainly the high diastolic blood pressure that was dangerous. An elevated systolic blood pressure, however, is as important as an elevated diastolic pressure. Such elevations in systolic blood pressure increase the risk of heart failure or stroke. The danger of heart failure is considerably increased if the patient has had a previous heart attack, heart failure, or has an enlarged heart.

B. New Convention, 2003

The Joint National Committee on Prevention, Detection, Evaluation, and Treatment of Hypertension, Seventh Report (JNC 7), gives a classification and management of blood pressure for adults (see Table 1). Individuals with an average blood pressure of more than 135/85 measured at home are generally considered to be hypertensive.

The heart rate multiplied by the systolic blood pressure is called the heart rate pressure product, and this product determines the oxygen requirement of the heart muscle. Elevation of the systolic blood pressure is just as bad as elevation of the diastolic in the range of 95–110 mmHg. Elevation of either systolic or diastolic is important, but the combined elevation is more common and further increases the risks. Drugs that decrease both the blood pressure and the heart rate are more effective in decreasing the oxygen requirement of the heart muscle. Beta-blocking drugs play a very important role in the drug treatment of hypertension because of the aforementioned effects.

III. CAUSES OF HYPERTENSION

A. Primary (Essential) Hypertension

In the majority of cases of hypertension, no detectable underlying disease is present. There are several theories as to why the blood pressure may be increased. This type

TABLE I
Classification and Management of Blood Pressure for Adults*

BP Classification	SBP ^a mmHg	DBP ^b mmHg	Lifestyle modification	Initial drug therapy	
				Without compelling indication	With compelling indications
Normal	<120	and <80	Encourage		
Prehypertension	120–139	or 80–89	Yes	No antihypertensive drug indicated.	Drug(s) for compelling indications. ^b
Stage 1 hypertension	140–159	or 90–99	Yes	Thiazide-type diuretics for most. May consider ACEI, ARB, BB, CCB, or combination.	Drug(s) for the compelling indications. ^c Other antihypertensive drugs (diuretics, ACEI, ARB, BB, CCB) as needed.
Stage 2 hypertension	≥160	or ≥100	Yes	Two-drug combination for most [†] (usually thiazide-type diuretic and ACEI or ARB or BB or CCB).	

DBP, diastolic blood pressure; SBP, systolic blood pressure.

Drug abbreviations: ACEI, angiotensin converting enzyme inhibitor; ARB, angiotensin receptor blocker; BB, beta-blocker; CCB, calcium channel blocker.

^aTreatment determined by highest BP category.

^bInitial combined therapy should be used cautiously in those at risk for orthostatic hypotension.

^cTreat patients with chronic kidney disease or diabetes to BP goal of <130/80 mmHg.

Modified from the Seventh Report of the Joint National Committee on Prevention Detection Evaluation and Treatment of High Blood Pressure. (NIH publication number 03-5233, May 2003).

of hypertension is called primary to distinguish it from secondary hypertension, for which causes can be defined with certainty. Primary hypertension has always been referred to as essential hypertension. The word “essential” was used because it was believed that higher pressures were needed to pump blood through arteries that were narrowed for some unknown reason. The use of the word has been so ingrained that it cannot be easily removed.

B. Secondary Hypertension

An underlying cause can be defined in only 5–10% of all hypertensive patients. The most common causes include (1) kidney diseases, (2) coarctation of the aorta, (3) endocrine (hormonal) diseases, and (4) use of birth control pills.

I. Chronic Kidney Diseases

These include pyelonephritis, nephritis (Bright’s Disease), congenital cysts in the kidney (congenital polycystic kidney), and blockage of the artery that feeds the kidney with blood (renal artery stenosis). These conditions are easy to exclude by taking a history, examining the kidneys and urine, and performing special x-rays such as a renal ultrasound, intravenous pyelogram (IVP), Doppler ultrasound for renal artery stenosis, and rarely, arteriograms of the kidneys. The renal causes of hypertension occur in all age groups: children may get nephritis;

blockage of the renal arteries may occur due to thickening of the muscular wall of the artery, especially in young women; or in the elderly, blockage may be caused by atherosclerotic plaques.

2. Coarctation of the Aorta

This is a severe constriction of the large artery (aorta) that leaves the heart. Although present from birth, the condition may not cause symptoms and may go undetected into childhood or adult life. This condition is easy to exclude. The blood pressure is low in the legs and the pulses to the legs (femoral felt in the groin) are weak and delayed compared with the pulses in the upper limbs. Chest x-rays and MRIs can confirm this diagnosis. In the majority of cases the condition is easily corrected by surgery. A recurrence of coarctation is successfully treated with balloon dilatation (angioplasty) and long-term observation is necessary. The blood pressure becomes elevated temporarily following coarctation, then normalizes, but hypertension recurs years later in some individuals. ACE inhibitors are preferred because the angiotensin system is stimulated (see the chapter Congenital Heart Disease).

3. Endocrine (Hormonal)

These diseases are usually due to an increase in hormone secretions from the adrenal glands that lie on the upper pole of each kidney. Cushing’s syndrome,

hyperaldosteronism (Conn's syndrome), pheochromocytoma, and hyperthyroidism are all diseases of the adrenal glands and birth control pills can sometimes cause mild hypertension.

Cushing's syndrome is an excess amount of cortisone and its derivatives that are secreted from the outer part (cortex) of the adrenal glands causing hypertension. Symptoms include a redistribution of fat and a typical moon face with obesity of the trunk. The arms and legs are relatively thin and the thigh muscles often become weak. Fortunately, surgery can produce a cure.

Hyperaldosteronism or Conn's syndrome is due to a small, benign tumor that secretes aldosterone. This hormone causes a retention of salt and water in the body and an excretion of potassium in the urine. Thus the serum potassium is low. The condition is rare and when diagnosed can be cured surgically.

Pheochromocytoma is a tumor in the center of the gland (medulla) that produces adrenaline (epinephrine) and noradrenaline (norepinephrine). This tumor causes excessive secretions and produces very severe hypertension. Fortunately, the condition is rare, only about 0.1% of all hypertensives have pheochromocytoma. This condition is important, however, because it is life-threatening, but when diagnosed, is surgically correctable. The features are often typical. In about 50% of cases, the blood pressure is relatively constant, and in the other 50%, the blood pressure fluctuates with paroxysms of severe hypertension occurring daily, weekly, or monthly.

The patient is quite well between episodes. During episodes symptoms include very severe, intolerable throbbing headaches; profuse sweating and palpitations; fear of impending doom; seizure-like activity or psychoneurotic spells; weight loss; and postural hypotension (the blood pressure is very high, but may fall on standing). The blood pressure may be normal for several days or months and then suddenly rise to levels of 190–300 systolic and 100–160 diastolic. Fortunately, this condition is easy to exclude by a urine test for adrenaline, noradrenaline, and breakdown products called vanillyl-mandelic acid (VMA) and metanephrines. A computerized tomographic scan (CT scan of the adrenals) will diagnose virtually all cases. Physicians and patient should be alerted by such symptoms and initiate screening tests when warranted. Another important clue to the diagnosis is a failure to respond to the usual antihypertensive drugs or a marked increase in blood pressure that may be provoked by certain drugs. For example, the patient's blood pressure may increase with certain medications such as nasal decongestants containing adrenaline-like compounds, antihypertensive agents such as methyl dopa, and opiates such as morphine and Demerol.

Hyperthyroidism is increased activity of the thyroid (hyperthyroidism, thyrotoxicosis) which occasionally causes mild systolic hypertension. Estrogen-containing oral contraceptive pills are also a cause of mild hypertension. In young women about 5% of users develop hypertension. The hypertension is usually mild, but rarely, severe hypertension can occur, resulting in kidney damage. On discontinuing the pill, the blood pressure returns to normal in the majority of women within six months. The increase in blood pressure described may be less with the newer, low-dose estrogen contraceptive pills. The low-dose, 0.625 mg, of conjugated estrogen used to treat postmenopausal hot flashes very rarely causes a mild increase in blood pressure.

C. Malignant Hypertension

This is a very serious condition. With malignant hypertension the diastolic blood pressure is usually greater than 130 for several hours or weeks. When such a diastolic blood pressure is associated with organ damage — notably to the vessels in the eyes, kidneys, or brain — the diagnosis is confirmed. The blood pressure increases rapidly over days or weeks to dangerous levels, and the systolic pressure may be as high as 250–300 mmHg and the diastolic pressure as high as 130–160 mmHg. The retinas of the eyes often show hemorrhages and edema of the optic disk. Small arteries are severely damaged; in particular the kidney vessels are damaged and leak red blood cells. The urine therefore contains numerous red cells (microscopic hematuria). The function of the kidney rapidly deteriorates and a brain hemorrhage may also occur. This is a life-threatening condition with severe damage to the kidney, brain, eyes, and heart.

Fortunately, the condition is decreasing in incidence because of effective drug treatment of the moderate forms of hypertension. The reassuring news is that it is rare for a patient with the very common mild primary hypertension to develop malignant hypertension. The patient usually has moderate hypertension for a short period with blood pressure ranging from 200 to 250/105 to 120. In some cases the malignant phase is precipitated by kidney disease, such as nephritis, but rarely renal vascular hypertension (renal artery stenosis) or collagen disease such as scleroderma or pheochromocytoma.

Malignant hypertension can be quickly brought under control by a range of effective drugs given intravenously. This form of hypertension cannot be treated without drugs. Blood pressure may be as high as 250/150, yet headaches can be absent. Other causes of hypertension include brain tumors, bleeding around the surface of the brain from a ruptured artery (subarachnoid

hemorrhage), spinal cord injuries, and the well-known pregnancy-induced hypertension.

IV. PATHOGENESIS OF PRIMARY ESSENTIAL HYPERTENSION

A. Salt Hypothesis

The hypothesis accepted by the majority of researchers is that an inherited defect causes the kidney to retain excess sodium (salt) in the body. If you have such an inherited defect and your diet contains a large amount of sodium, your kidneys will retain more sodium and water. A normal kidney that has no defect in handling sodium will expel in the urine any excess that you may add in the diet. The sodium and water retained by the kidney get into the blood and also into the cells of the artery wall, thereby increasing the tone of the artery wall. This means that the artery becomes constricted or tightened and increases the resistance against which the heart must pump, that is, there is an increase in total vascular resistance and an increase in blood pressure (see Fig. 2).

The relationship between salt and hypertension is easier to understand after looking at the following example. If an individual is bleeding severely from a large cut or from the stomach or other body site, the blood pressure

always falls, sometimes to very low levels such as 75/50. A transfusion of blood must be given quickly to increase the blood pressure, because at such a low level, not enough oxygen, glucose, and other nutrients will reach the brain, muscles of the heart, and other tissues of the body. However, blood is not usually available in emergency rooms for up to two hours. During this time the doctor rapidly gives sodium chloride (salt) diluted in water into a vein (intravenous saline), and this nearly always increases the blood pressure to safe levels until blood is available. During the bleeding described, the kidneys also immediately start to retain sodium and water and return it to the blood; that is, the kidney gives us an immediate transfusion of saline. Nature always finds a way to compensate.

Increased salt intake is believed to be the most important factor causing hypertension in susceptible individuals. The evidence is strong enough to warrant general education of the public. The U.S. Food and Drug Administration, WHO, the American Heart Association, the American Medical Association, the National Heart, Lung, and Blood Institute, and two government-sponsored bodies in the UK have advised the general population to reduce sodium consumption where possible (see Table 2).

There is a considerable amount of scientific information that supports the view that increased salt intake causes hypertension in susceptible individuals:

- Population groups that consume very low amounts of sodium, less than 2 g daily, have almost no primary hypertension; for example, groups in South America, Africa, and the South Pacific. In contrast, in countries such as Japan and Korea, where sodium intake is excessively high, i.e., greater than 6 g daily, hypertension is very common.
- Twenty-seven studies in human populations have shown a close correlation between sodium intake and blood pressure.
- There was a fall in the incidence of hypertension in Japan between 1971 and 1981, and this is believed to be due to a fall in the daily sodium consumption from above 6 g to less than 4 g.
- In Belgium, between 1968 and 1981, a fall in daily sodium consumption from greater than 6 g to less than 4 g was associated with a significant fall in mortality due to stroke.
- In children of hypertensive parents, increased sodium intake causes an increase in blood pressure and a greater rise in blood pressure after stress.
- Compounds that cause sodium and water retention by the kidney (hydrocortisone, licorice) often increase blood pressure. In patients with Addison's disease, low blood pressure is always present and is treated with

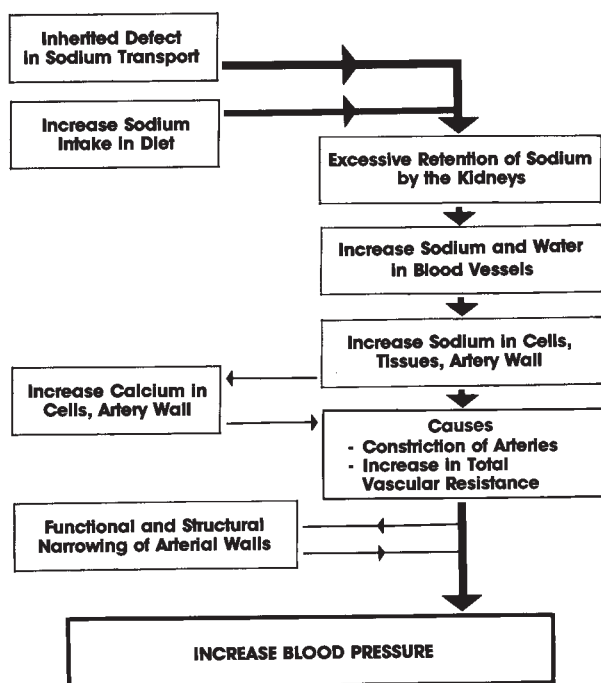

FIGURE 2 Hypothesis for the causation of primary (essential) hypertension.

TABLE 2
Sodium Content of Foods

Food	Portion	Sodium (mg)
Bacon back	1 slice	500
Bacon side (fried crisp)	1 slice	75
Beef (lean, cooked)	3 oz (90 g)	60
Bouillon	1 cube	900
Garlic powder	1 tsp (5 ml)	2
Garlic salt	1 tsp (5 ml)	2000
Ham, cured	3 oz (90 g)	1000
Ham, fresh cooked	3 oz (90 g)	100
Ketchup	1 tbsp (15 ml)	150
Meat tenderizer, regular	1 tsp (5 ml)	2000
Meat tenderizer, low-sodium	1 tsp (5 ml)	2
(Whole) milk	1 cup (250 ml)	1000
pudding, instant		
Olive, green	1	100
Peanuts, dry-roasted	1 cup (250 ml)	1000
Peanuts, dry-roasted, unsalted	1 cup (250 ml)	10
Pickle, dill	1 lrg (10 × 4 1/2 cm)	1900
Wieners	1(50 g)	500
Canned foods		
Carrots	4 oz (60 ml)	400
Carrots, raw	4 oz (60 ml)	40
Corn, whole kernel	1 cup (250 ml)	400
Corn, frozen	1 cup (250 ml)	10
Corned beef, cooked	4 oz (120 g)	1000
Crab	3 oz (90 g)	900
Peas, green	1 cup (250 ml)	5
Shrimp	3 oz (90 g)	2000
Salmon, salt added	3 oz (90 g)	500
Salmon, no salt added	3 oz (90 g)	50
Soups (majority)	1 cup (250 ml)	1000
Sauerkraut	1 cup (250 ml)	1800
Salad dressing		
Blue cheese	1 tbsp(15 ml)	160
French, regular	1 tbsp(15 ml)	200
Italian	1 tbsp(15 ml)	110
Oil and vinegar	1 tbsp(15 ml)	1
Thousand island	1 tbsp(15 ml)	90
Fast food		
Chopped steak	1 portion	1000
Fish and chips	1 portion	1000
Fried chicken	3-piece dinner	2000
Hamburger	Double	1000
Roast beef sandwich	1	1000
Pizza	1 medium	1000

Normal diet contains 1000 to 3000 mg of sodium. Daily requirement is less than 400 mg.

cortisone. Cortisone retains sodium with water, and this effect always increases blood pressure. Diuretic drugs cause the kidney to remove excess sodium from the blood and expel the sodium and water in the urine and thus cause a decrease in blood pressure.

- Patients with chronic kidney failure who lose excessive sodium in the urine tend to have a normal blood pressure, but in those who retain excessive sodium, blood pressure is often elevated.
- Animal experiments show a close relationship between salt intake and hypertension.

Despite the aforementioned points that incriminate an increased salt intake with hypertension, the Medical Research Council blood pressure unit in Glasgow states that the evidence is unclear and unproven. Thus, they do not feel it justified to ask everyone to reduce sodium intake. There are many individuals who handle salt adequately. In this situation, we cannot advise everyone to reduce salt intake and we agree with the following: There is a consensus in North America and Europe that a moderate reduction in salt intake to less than 2 g has no adverse health effects, and whenever possible, it would be prudent for the general population to reduce sodium intake, particularly, patients with primary hypertension in their relatives. If you have kidney disease, you should not reduce salt intake unless advised by a physician (some kidney patients can reduce intake).

The evidence suggesting an inherited kidney defect stems from the work of Dr. Lewis Dahl who bred two strains of rats, one that consistently developed hypertension when given an increased sodium diet, and the other that resisted the development of hypertension and never became hypertensive while on the same diet. Further, when a kidney is taken from a hypertensive rat and transplanted into a host rat with a blood pressure that is in the normal range (normotensive rat), the blood pressure of the host rat rises. A kidney transplanted from a normotensive rat lowers the blood pressure of a hypertensive host rat. It is believed that both the genetic and environmental factors (salt, stress, etc.) act together to cause hypertension.

B. Other Hypotheses

Other hypotheses for the causation of primary hypertension are shown in Fig. 3. Hereditary factors and stress cause an increase in discharge from a center in the brain (sympathetic center) which triggers the secretion of adrenaline and noradrenaline. These compounds not only cause an increase in heart rate and cardiac output, but a marked constriction of arteries and increased total vascular resistance too, thereby increasing blood pressure. This

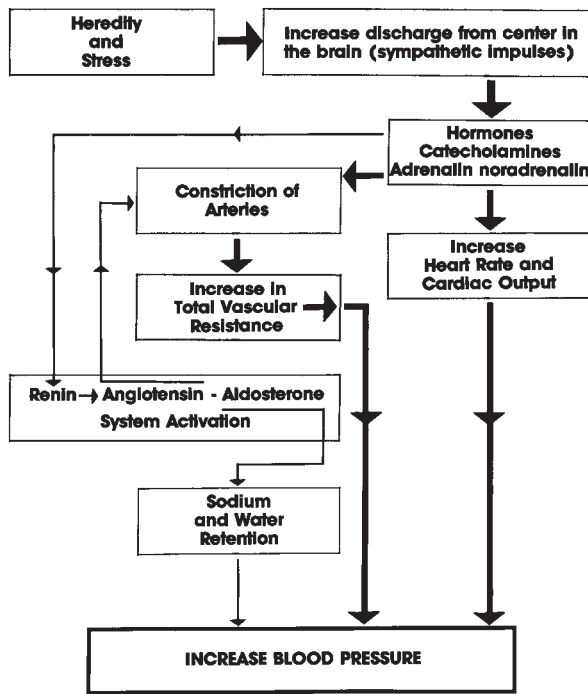

FIGURE 3 Other hypotheses for the causation of primary hypertension.

sympathetic stimulation activates enzymes in the kidney and adrenal glands (the renin-angiotensin-aldosterone system). Angiotensin is a powerful constrictor of arteries which elevates blood pressure. Aldosterone, a hormone secreted by the adrenal glands, causes the kidney to retain sodium and water and this further increases blood pressure. The renin-angiotensin-aldosterone system appears, however, to have only a small role, and this is still undefined in the causation of primary essential hypertension. A low intake of calcium has been associated with an increase in blood pressure in two studies, but the evidence is not sufficient to implicate a low-calcium intake in the causation of hypertension. Further studies are necessary to clarify the aforementioned theories of causation.

V. COMPLICATIONS

A. Effects on Arteries and Heart

1. Myocardial Infarction

Hypertension damages the arteries in many vital organs, especially the brain, heart, kidneys, and eyes. Damage to the walls of the arteries is due to the increase in blood pressure, but important added factors are an increase in pulsatile force and velocity of the blood. The artery

wall responds to this stress by thickening its walls, but this leads to further narrowing of the arteries and a further increase in blood pressure. The arteries must branch to supply blood to various organs and tissues. Unfortunately, the branches to some areas take off at near right angles and mechanical stress is greatest at these points. The high velocity and pulsatile force of blood at a high pressure set up turbulence and mechanical stress that damage the smooth lining of the arteries, occasionally causing small tears (dissections) of the arteries. This mechanical injury provokes proliferation of smooth muscle cells of the artery walls and accumulation of fatty material including cholesterol and small blood particles (platelets). This thickening produces a plaque (atheroma) that juts out into the lumen of the artery thus obstructing blood flow, which causes low flow and turbulence in the artery.

The term for hardening of the artery is sclerosis, hence the combination "atherosclerosis," meaning hardening of the arteries due to atheroma (see atherosclerosis in the glossary). This process is continuous over several years and produces no symptoms. On these plaques or damaged points, a blood clot (thrombosis) may eventually occur in vital organs such as the brain, heart, or kidney.

In the heart, the coronary arteries feed the heart muscle with blood. A blockage of a coronary artery by atheromatous plaque or clot causes damage to the heart muscle, myocardial infarction that may be complicated by heart failure, arrhythmia, angina, and death.

2. Heart Failure

High blood pressure causes enlargement and thickening of the heart muscle. These changes may be observed occasionally on examining the patient or detected on chest x-ray or ECG. At some point in time, the heart muscle weakens and thus fails to eject sufficient blood into the arteries to satisfy the needs of the tissues; this is called a failing heart or heart failure (see the chapter Heart Failure). Blood that cannot be ejected into the aorta backs up into the lungs, which causes stiffness of the lung tissue and leakage of fluid into the air sacs (alveoli). These changes in the lungs cause severe shortness of breath. Heart failure can be precipitated by mild hypertension in patients who already have a damaged heart muscle due to an old heart attack (weakened scar). There are many other causes of a weakened heart muscle, however, hypertension of all grades is detrimental in all types of heart disease. In African-Americans, heart failure is precipitated at a lesser degree of hypertension than in whites.

Studies indicate that approximately 66% of elderly patients with heart failure had antecedent hypertension.

The bulk of heart failure is related to hypertension and myocardial infarction. Effective hypertension control is the single greatest means to prevent diastolic and systolic heart failure. Most important diastolic heart failure has no effective therapy and prevention is the key.

3. Abdominal Aortic Aneurysm

Hypertension can weaken the wall of the aorta. The wall may balloon and produce a weak spot, and this is referred to as an aneurysm of the aorta. The weak spot may rupture and this is often catastrophic and the condition can be confused with a severe heart attack (see the chapter Aneurysm). The risk of narrowing or blockage of the arteries in the legs (peripheral vascular disease) is increased by hypertension, especially when there is either associated smoking, high cholesterol, or diabetes.

4. Arrhythmia

The most common arrhythmia caused by hypertension is atrial fibrillation. It is the most common sustained arrhythmia encountered in clinical practice (see the chapter Atrial Fibrillation). Figure 4 illustrates the common detrimental effects of hypertension.

B. Stroke

In the brain, a blockage (cerebral thrombosis) or rupture (hemorrhage) of an artery produces damage to a segment of cells, which results in weakness or paralysis of limbs. This is referred to as stroke. Each year about 500,000 North Americans suffer a stroke and more than 200,000 die as a result.

C. Kidney Damage

In the kidney, hardening of the arteries leads to reduced blood flow and chronic deterioration of the

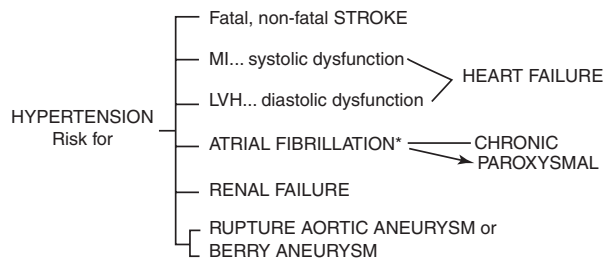

FIGURE 4 Common detrimental effects of hypertension. * = Not well appreciated: epidemic of atrial fibrillation with its management problems. (From Khan, M. Gabriel (2003). *Cardiac Drug Therapy, sixth edition*. Philadelphia: W.B. Saunders.)

kidney function, and this causes a further increase in blood pressure. Fortunately, only in patients with severe hypertension is kidney failure a final occurrence. The vessels in the back of the eyes may be damaged by high blood pressure, and the changes may be observed on examination with an ophthalmoscope.

VI. SYMPTOMS

There is little doubt that hypertension either leads to early death or inflicts serious physical handicaps to millions. Blood pressure may be mildly or moderately elevated for several years without symptoms until the occurrence of stroke, heart attack, or heart failure.

Symptoms may not occur for 5–20 years in the majority of patients with mild and moderate primary hypertension. Headaches, dizziness, and nose bleeds occur with equal frequency in hypertensives as they do in individuals with normal blood pressure. Some individuals get headaches during sudden elevations of blood pressure. Only in a few patients can symptoms be correlated with the height of blood pressure. Because your blood pressure may be very high and yet produce no symptoms, it is necessary to have a blood pressure check once a year or more often if you were ever informed that your blood pressure was above normal.

VII. INVESTIGATIONS

Blood, urine, and other tests are performed to determine if hypertension is primary, that is, without a cause, or secondary to diseases of organs, especially the kidney. These tests will also serve as a baseline for future comparison and as a means for detecting side effects of some antihypertensive drugs. The tests and the reasons for their use are listed below.

- A complete blood count determines the number of red and white blood cells in your blood. The red blood cells contain hemoglobin; heme is the iron in your blood, and this is combined with a protein called globin. The level of hemoglobin will indicate if you are low in blood (anemia). A very high hemoglobin (polycythemia) is a rare cause of hypertension.
- A test for electrolytes measures the amount of sodium, potassium, and chloride in the blood. The potassium level in the blood is important as it may fall if you are taking a water pill (diuretic), which is commonly used to treat hypertension. The potassium level may increase with the use of ACE inhibitors.

- Either the blood urea nitrogen (BUN) or serum creatinine must be obtained. Urea and creatinine are waste products excreted by the kidney into the urine. The level of these substances in the blood is fairly constant when the kidney is functioning normally, but rises in kidney dysfunction. The results of these tests will show if the kidney is the likely cause of your hypertension.
- A urine test (urinalysis) may show excess proteins, bacteria, or fragments of cells (casts) in the urine, which indicates kidney disease.
- A chest x-ray is necessary and will tell the doctor if the heart is normal in size or already enlarged due to hypertension.
- An ECG can more accurately tell if the heart is enlarged and under strain. A chest x-ray cannot indicate whether the left ventricle of the heart is strained by the high blood pressure. The ECG may also give other important information. The reassuring news is that other tests are necessary in only a few hypertensive patients, perhaps 5 out of 100 patients.
- In a few hypertensive patients with suspected kidney disease, an intravenous pyelogram (IVP) may be requested by the doctor. A dye that can be seen easily on x-ray is injected into a vein in the arm and reaches the kidney within a few minutes. X-rays of the kidneys are taken over a 20-minute period. If the kidney is functioning normally, the dye is excreted into the urine and the x-ray will show the kidney structure as well as give some indication of kidney function. A renal nuclear scan may be done instead of IVP and is a safer test.
- Special urine tests for the breakdown products of adrenaline (nor metanephrines) as indicated earlier are rarely required to exclude a tumor (pheochromocytoma) of the inner part of the adrenal gland, which secretes adrenaline.
- A dye test showing the arteries of the kidney (arteriogram) may be required if your doctor suspects from the renal scan or IVP that the artery to the kidney is obstructed. This is a rare occurrence and is seen in about 1 in 1500 patients.

VIII. NONDRUG TREATMENT

The majority of patients with mild primary hypertension are advised to persist with a one-year trial of nondrug treatment. It is important to understand the essential requirements of the program. The hypertensive must be aware of the dangers of the so-called silent killer to become sufficiently motivated to comply with self-imposed treatment. Individuals who persist with nondrug treatment

have a 50% chance of lowering blood pressure to normal. The essential requirements are given in order of importance, and each will be discussed in detail below.

- Sodium in the diet should be reduced to less than 2 g daily and at maximum 3 g (see Table 2).
- Weight reduction is absolutely necessary and is always associated with a fall in blood pressure. The loss of 15–30 pounds always causes a considerable drop in blood pressure and medications may not be required.
- Removal of stress or learning to adjust to stress may result in reduction of high blood pressure, and a trial of relaxation techniques can be useful in some individuals.
- Regular exercise will assist with weight reduction and relaxation.
- Alcohol intake should not exceed two ounces daily.
- The patient should reduce coffee intake and must stop smoking.

A. Sodium (Salt) Restriction

Sodium added at the table is only a minor part of the daily sodium consumption. A teaspoon, 5000 mg of salt (sodium chloride), contains 2000 mg of sodium (i.e., 40%). The body requires an intake of less than 400 mg daily. The daily North American diet contains about 4000–6000 mg of sodium (two to three teaspoons of salt). Clearly no one adds more than a teaspoon of salt daily at the table or in cooking for a family. The remaining one to two teaspoons must come from the food we eat.

The aim is to cut sodium intake by 50%, to 2 g daily. This can be accomplished only if the hypertensive or potential hypertensive recognizes and reduces or discontinues foods that have a high-sodium content. The list is long and contains many surprises (see Table 2). The physician, the dietary adviser, and the patient must be alert and check the sodium content of foods consumed during one-week periods. Foods that are not salty to taste may have a very high sodium content. Note that some puddings have more sodium than a helping of bacon. A large dill pickle has more than 1 g of sodium. Fast foods have a high sodium content (hamburgers 1 g, three pieces of fried chicken, 2 g). Watch out for canned foods that have excess sodium added as preservatives.

Other high-sodium foods not listed in the table include soy sauce, onion salt, celery salt, seasoned salt, salted crackers, pretzels, rye rolls, salted popcorn, most canned vegetables, sausage, hot dogs, salt pork, sardines, smoked fish, TV dinners, buttermilk, waffles, and pies.

It is obvious from Table 2 that the hypertensive individual must look at food labels and determine if foods have a low- or high-sodium content. Anything that has more

than 500 mg per can is high. Additives are listed on tins in order of greatest quantity. Sodium benzoate, sodium nitrate, or monosodium glutamate means sodium. Therefore, if any sodium compound is in the first five of the additives and the milligram content is not given, it is best to avoid the product. After a month or two of care, it will become second nature to purchase foods with a low-sodium content. If you cannot avoid canned foods, rinse the vegetables, tuna and the like under running water. Low sodium intake is possible if you use fresh poultry, fish, beef, fruits, and vegetables. Season foods with spices and herbs instead of salt and use a low-sodium meat tenderizer. Onions and raw tomatoes can be used liberally in cooking. All hypertensives should have dietary counseling at least once annually. The sodium content of several over-the-counter antacids used for indigestion and stomach upsets is high. There are, however, several brands on the market that have a very low sodium content, so please read the labels or ask your doctor.

Salt substitutes that contain potassium in place of sodium are helpful and can be used in place of table salt, except in patients who have kidney disease or take medications that retain potassium. You may need to try out several salt substitutes to find one that has a reasonable taste. Garlic powder but not garlic salt, onion powder but not onion salt, and chili powder may be useful to improve taste and yet remain low in sodium. Tomato juice and all the tomato sauces are high in sodium, but manufacturers are producing low-sodium tomato juices and a wide range of canned products.

B. Weight Reduction

A loss of weight always produces a fall in blood pressure and is therefore strongly recommended. Weight reduction has a greater blood pressure lowering effect than exercise, relaxation techniques, and or sodium restriction. A weight-reducing, low-salt diet is often prescribed, but many patients fail to stick to a diet. Thus the diet must be individualized. It is best to refer to a dietary adviser, who can at least review the patient twice annually.

Hypertension carries a greater risk of heart attack and stroke in patients with an elevated cholesterol. For patients under age 55, the serum cholesterol should be maintained at less than 200 mg/dl (5 mmol). The risks are considerably increased if the serum cholesterol is greater than 240 mg/dl (6 mmol). It is important when following a weight-reduction diet not to increase intake of foods that are high in cholesterol. Low-cholesterol diets and the optimal levels of total serum cholesterol and high-density lipoprotein (good) cholesterol are discussed in

the chapter Cholesterol. Weight-reduction diets must be individualized; therefore, no specific recipes are given in this book (see the chapter Obesity and Heart Disease).

C. Stress

The role of stress in high blood pressure is difficult to define. What is important is the way we handle stress. Stress itself rarely produces sustained hypertension, but in a susceptible individual with an inherited predisposition to hypertension, stress may increase blood pressure (see Fig. 3). It is important to recognize that an individual with an average blood pressure of 135/85, when under stress, can increase blood pressure 20–40 mmHg systolic and 5–10 mmHg diastolic. These increases in blood pressure may last minutes or several hours several times daily, and play an important role over several years. Thus, the patient with mild primary hypertension on non-drug therapy will increase blood pressure significantly during the day under the influence of stress. The use of relaxation therapy has increased dramatically and many clinics offer relaxation facilities, although scientific studies have failed to show a sustained decrease in blood pressure due to this therapy. On the other hand, some studies are emerging that lend support to the salutary effect of relaxation therapy. Biofeedback-aided relaxation therapy seems to benefit some patients. This mode plus deep relaxation exercises are not harmful and can reduce blood pressure in some patients. Because the blood pressure tends to increase between periods of relaxation, do not rely solely on relaxation therapy if your blood pressure is greater than 160/100. Occasionally patients may need to change jobs, reduce workload, or to engage in hobbies such as tennis, golf, swimming, fishing, painting, listening to music, or other forms of recreation.

D. Exercise

Isometric (static) exercise, such as weightlifting (pulling, pushing), increases muscular tension and constricts blood vessels, thus increasing blood pressure. Such exercises must be avoided. Isotonic or aerobic exercises may cause a variable increase in blood pressure during the exercise and slight decrease immediately following the exercise. Walking, jogging, swimming, and other forms of exercise should be encouraged in mild hypertensives. A fall in blood pressure may be related to weight loss and relaxation produced by exercise. If blood pressure remains elevated greater than 160/100 after six months of an exercise program, do not rely on exercise as a sole means to lower blood pressure (see the chapter Exercise and the Heart).

E. Alcohol

There is convincing evidence that any more than three ounces of liquor daily significantly increases blood pressure. Alcohol should therefore be restricted in all hypertensives. It is often stated that alcohol may produce relaxation, and two to four ounces daily may relax the nerves as well as increase the levels of HDL, the so-called good cholesterol. The ideal choice is a drug that is effective for 24 h when given once daily that produces little or no adverse effects. Several drugs are effective only for six to eight of hypertension is greater than the possible benefits of a modest and variable increase in HDL cholesterol. Alcohol should be avoided in patients who have both hypertension and increased HDL cholesterol and heart failure. Four ounces of alcohol taken over a few hours causes a decrease in contraction of the heart muscle, thereby reducing the amount of blood ejected from the heart at each beat (see the chapter Alcohol and the Heart).

F. Coffee and Smoking

Coffee is also known to stimulate the sympathetic nervous system and can cause mild elevation of blood pressure in susceptible individuals, especially if more than three cups per day are consumed. Tea has much less caffeine than coffee and is not known to increase blood pressure.

Smoking definitely increases the cardiovascular risk in patients with hypertension. Also, many drugs do not work efficiently to lower blood pressure because smoking interferes with their metabolism in the liver. The patient must therefore be motivated to discontinue smoking cigarettes.

IX. DRUG TREATMENT

A. Number of Drugs Available

Hypertension affects more than 1 billion individuals worldwide and is the most common indication for both visits to physicians and for the use of prescription drugs in the United States, yet there are only five groups of drugs available to treat this condition. After more than 50 years of research and proclamations on television and in popular magazines of new drugs, the hope of patients dissipates when the new agents are tried without success. This situation is appalling when worldwide more than 1 billion individuals require treatment.

Only five antihypertensive drugs are available.

1. Diuretics
2. Beta-adrenergic blockers

3. ACE inhibitors and angiotensin II receptor blockers
4. Calcium antagonists (calcium channel blockers)
5. Alpha blockers (use limited because of increased risk for heart failure)

ACE inhibitors and the identical acting angiotensin II receptor blockers are a major advance but represent a single class of agent. Although this class of agent is represented by more than 24 drug names in the marketplace, they have the same actions and represent a single drug

Calcium antagonists are not superior to the two older classes of agents, beta-blockers and diuretics. *Alpha-blockers are not recommended agents and the recent ALLHAT trial indicates that they increase the incidence of heart failure.* These agents are therefore used only in selected individuals, particularly with renal dysfunction, when an ACE inhibitor may be contraindicated and blood pressure remains uncontrolled with other agents. The older centrally acting agents clonidine and methyldopa caused depression and other adverse effects and have been rendered obsolete, although methyldopa still holds a place in the management of hypertension in pregnancy.

In reality they are only four groups of antihypertensive agents available. In clinical practice patients who cannot tolerate one or two of the four types of agents are frequently encountered and many patients require two agents to maintain adequate blood pressure control.

The following statement is modified from the sixth edition of *Cardiac Drug Therapy*:

This situation will change only if pharmaceutical companies and experts who formulate hypertension therapeutic guidelines will admit that after more than 50 years of research and numerous randomized clinical trials we only have four antihypertensive agents. Recognition of the truth should promote more intensive research to discover new groups of agents to add to our armamentarium.

The organizers of randomized trials must provide sound methodology, which has been lacking in many trials. For example, the well-known beta-blocker, atenolol, has been compared with other agents in several trials. However, the nonlipid-soluble atenolol is not as cardioprotective as carvedilol, metoprolol, bisoprolol, or propranolol, which are the only beta-blockers proven in clinical trials to be cardioprotective. Beta-blockers have subtle and important differences that appear to be unrecognized by experts who organize clinical trials of hypertension.

The physician should explain the problems associated with drug therapy so that the patient will accept

and comply with drug changes, which are often necessary.

The standard approach to antihypertensive treatment is to use a beta-blocker or a diuretic as the initial drug. In recent years beta-blockers have partially replaced diuretics as the first-line drug, but both drugs are advocated by national consensus committees as the recommended agents to commence treatment, except in special cases.

Experts vacillate between drugs as to their choice of a first-line drug. Other drugs can be used as first-line in selected individuals. Another important group of drugs that have proved beneficial in the treatment of moderate and severe hypertension are called angiotensin-converting enzyme (ACE) inhibitors. They are called this because they block the action of a series of enzymes (angiotensin, renin). (See chapter entitled Angiotensin-Converting Enzyme Inhibitors/Angiotensin Receptor Blockers.) Angiotensin causes powerful constriction of arteries and therefore increases blood pressure when the body requires a boost in blood pressure. By blocking angiotensin, these drugs cause dilation of the arteries and a fall in blood pressure. In addition they do not stimulate the heart to beat faster as do some drugs. They also retain potassium whereas diuretics cause a loss of potassium. This group of drugs (ACE inhibitors) includes captopril and enalapril. Another group of drugs recommended by the consensus panel are the calcium blockers (antagonists).

The drug treatment of hypertension must be individualized. In order to assist doctors to accomplish this goal, a past history of illnesses and response or bad reaction to drugs must be given.

- Previous response or adverse effect to antihypertensive drugs should be a factor in determining further drug treatment.
- A beta-blocker (for example, metoprolol, propranolol, or bisoprolol) is the drug of choice if the patient has angina or palpitations or has had a heart attack or a strong family history of heart disease. Patients from 25 to 75 years of age usually respond to beta-blockers. Your doctor must respect the contraindications to the use of beta-blockers. Beta-blockers must not be used if a patient has bronchial asthma or emphysema.
- Patients with stroke or poor circulation to the brain associated with postural hypotension (a big fall in blood pressure on standing) should avoid the use of methyl-dopa, prazosin, or hydralazine and other drugs that cause considerable dilatation of the arteries on standing. Such drugs cause more blood to go down to the legs on standing and therefore steal blood from the brain, which causes dizziness. It is important to note that

beta-blockers do not cause postural hypotension and are therefore useful in this group.

Four main groups of drugs are in use:

1. Beta-blockers
2. Diuretics
3. Vasodilators (including ACE inhibitors and calcium antagonists)
4. Drugs that act centrally in the brain

Before outlining the drugs used in hypertension and some of their side effects and doses, it is wise to reflect on the following important question: Is the choice of drug or dosage really important in reducing blood pressure? The answer to this question is yes. The choice of drug and dosage is important. The available evidence suggests that beta-blockers have a definite advantage over diuretics and other agents as first-line therapy. When utilized, diuretics should be given in the smallest dosage necessary to control blood pressure, for example, hydrochlorothiazide, 25 mg daily. Hypokalemia (low serum potassium) must be avoided. A diuretic that conserves potassium such as Moduretic (Moduret) or Dyazide has a definite place in therapy if kidney function is normal (see contraindications to Moduret or Dyazide use in Section IX.D.2.c and d).

The following points must be considered when giving a patient an antihypertensive drug. It is not only the severity of hypertension that damages the arteries, but (1) the added pulsatile force of the blood; (2) the heart rate multiplied by the systolic blood pressure, which determines the workload of the heart and the amount of oxygen the heart muscle requires (thus an enlarged heart muscle working under strain will require more oxygen); and (3) the peak velocity of the blood multiplied by the heart rate, which reflects the turbulence of blood (turbulence causes damage to the inner lining of arteries). These three parameters can be favorably influenced by beta-blockers, made worse by diuretics or vasodilators such as prazosin, and not altered by drugs that act centrally in the brain.

Beta-blockers are effective in preventing death in patients who have sustained a heart attack and are treated with these drugs for an additional two years. Four beta-blocking drugs have been studied in large clinical trials: acebutolol, 400 mg daily; metoprolol, 120–200 mg daily; propranolol, 160–240 mg daily; and timolol at a dose of 10–20 mg daily were effective in preventing fatal and nonfatal heart attacks. Interest should be centered on the potential complications and not just the blood pressure. The patient is not only worried about his blood pressure but is afraid of stroke or heart attack. Doctors sometimes lose sight of this goal. They give drugs to reduce the blood pressure and forget that some drugs do prolong life longer

than others (see the section Beta-Blockers in the chapter Heart Attacks).

B. Choice of Antihypertensive Agent for Patients Without Coexisting Disease

Patients with primary essential hypertension who have no complications of hypertensive disease and no coexisting issues such as diabetes or pulmonary disease are selected for a particular drug depending on age and whether the individuals is white or of African descent.

1. Recommendations for White Patients Less than Age 65

Initial choice begins with either a beta-blocking drug or a diuretic. Several randomized clinical trials (RCTs) have emphasized the efficacy and safety of these agents and the cost-savings to patients when these old agents are used. Newer agents including ACE inhibitors, angiotensin II receptor blockers (ARBs), and calcium antagonists are not superior.

The clinician should strive for the use of one agent in the treatment of hypertension whenever possible. The combination of two agents at a low dose, however, may achieve the therapeutic goal with less potential for adverse effects and often combination therapy is required to attain the therapeutic goal blood pressure.

2. Recommendations for Younger Black Patients

Calcium antagonists are the most effective agents of the four groups followed by beta-blockers. The combination of a small dose of a beta-blocking drug such as bisoprolol, 10 mg daily, plus a calcium antagonist such as amlodipine, 5 mg daily, should attain goal blood pressure.

3. Recommendations for White Patients Older than Age 65

A beta-blocking drug or ACE inhibitor is a reasonable first choice of agents, but a small dose of diuretic may be tried and then a small dose combination (see Table 3).

4. Recommendations for Elderly Black Patients

A diuretic is the treatment of choice. Calcium antagonists are also effective, but in patients with an ejection fraction of less than 40% the risk of heart failure may be increased.

TABLE 3

Choice of Drug for the Treatment of Isolated Systolic Hypertension

White patients younger than age 65	
1.	Beta-blocker: bisoprolol carvedilol or metoprolol (Toprol XL) preferred over other beta-blockers.
2.	ACE inhibitor: often requires combination with diuretic to achieve goal BP
3.	Diuretic
4.	Choice one or two +3
Black patients younger than age 65	
1.	Beta-blocker
2.	Calcium antagonist
3.	Choice 1 + 2
White patients older than age 65	
1.	Beta-blocker
2.	ACE inhibitor
3.	Diuretic
4.	Choice 1 + 2 (not complementary but both cardioprotective, >65 at risk)
5.	Calcium antagonist
Black patients older than age 65	
1.	Diuretic
2.	Calcium antagonist
3.	Choice 1 + 2

From Khan, M. Gabriel (2003). *Cardiac Drug Therapy, sixth edition*. Philadelphia: W.B. Saunders, p. 140.

C. Therapy for Patients with Coexisting Diseases or Target Organ Damage

Coexisting diseases of importance include diabetes, coronary artery disease (angina), myocardial infarction, previous coronary artery bypass surgery, left ventricular dysfunction, dyslipidemia, stroke or transient ischemic attack, kidney disease (nephropathy), and peripheral vascular disease. Target organ damage includes heart failure, left ventricular dysfunction, left ventricular hypertrophy retinopathy, and renal insufficiency.

Patients with coronary artery disease manifested by angina or myocardial infarction should be treated with a beta-blocking drug such as propranolol, carvedilol, or bisoprolol. If beta-blockers are contraindicated a calcium antagonist such as diltiazem sustained-release preparation may be tried. Dihydropyridine calcium antagonists increase heart rate and may precipitate heart failure and should not be used without a beta-blocking drug. A diuretic is always useful in this group of patients and combination with a beta blocker or ACE inhibitor provides benefits.

An ACE inhibitor is particularly useful if left ventricle dysfunction is present and the combination of a beta-blocker and an ACE inhibitor is advisable, because these two agents have been shown to be cardioprotective.

In patients with diabetes a combination of two or more drugs is usually needed to achieve the target goal of less than 130/80 mmHg. ACE inhibitors and angiotensin receptor blockers favorably affect the progression of diabetic nephropathy and reduce albuminuria. Angiotensin receptor blockers have been shown to reduce progression to microalbuminuria. A beta-blocker is strongly recommended in addition to other agents because beta-blocking drugs have been shown to reduce cardiac death in patients at risk.

Patients with heart failure and hypertension are best treated with a combination of a loop diuretic, ACE inhibitor, and a small dose of a beta-blocker. In the absence of renal artery stenosis in patients with kidney disease, an ACE inhibitor or angiotensin receptor blocker in combination with a diuretic, a beta-blocker, and calcium antagonist may be required to attain goal a blood pressure less than 130/80. Patients with renal artery stenosis may have an accelerated hypertension that is difficult to control. Goal blood pressures in these patients should be at a high level of 140–150 mmHg systolic and diastolic 75–90 mmHg to allow adequate renal perfusion. Low blood pressures may cause deterioration of kidney function

D. Individual Antihypertensive Agents

See Tables 7 and 8 for dosage and generic and trade names for the individual agents.

I. Beta-Blockers (Tables 4 to 6)

Beta-blockers are excellent antihypertensive agents for the following reasons.

- They do not cause a fall in blood pressure on standing, unlike most other antihypertensive agents. Labetalol,

TABLE 4

Generic and Trade Names of Beta-Blockers

Generic	Pharmaceutical trade names
Acebutolol	Monitan, Sectral
Atenolol	Tenormin
Metoprolol	Lopressor, Betaloc, Seloken, Toprol XL
Nadolol	Corgard, Solgol
Pindolol	Visken
Propranolol	Inderal, Angilol, Apsolol, Berkolol
Timolol	Blocadren, Betim, Temserin

TABLE 5

Dosage of Commonly Used Beta-Blockers

Beta-blocker	Daily starting dose (mg)	Maintenance dose (mg)	Maximum suggested dose (mg)
Acebutolol	100–400	200–600	1000
Atenolol	50	50–100	100
Bisoprolol	5	10–15	20
Carvedilol	6.25	12.5–25	50
Metoprolol	50–100	100–300	400
Nadolol	40–80	80–160	160
Propranolol	60–120	80–240	240
Timolol	5–10	20–30	30

which is really an alpha- and beta-blocker, does cause postural hypotension. This drug is useful in hypertensive emergencies, but it is not recommended for the long-term treatment of hypertension because of potential adverse effects.

- Beta-blocker drugs produce no major side effects on heart, liver, kidney, blood, or bone marrow.
- The one-a-day schedule necessary for these drugs makes it less likely for the patient to forget to take the drug.
- They can be used alone as first-line therapy and are effective in more than 60% of hypertensive patients aged 25–75, and used successfully in the majority of patients in combination with a small dose of a diuretic or with an ACE inhibitor or calcium antagonist. They curb some adverse effects of vasodilator drugs including calcium antagonists.
- They prevent hypertrophy of the heart muscle. They reduce the incidence of stroke, heart failure, heart attacks, and deaths from heart attacks.

Beta blockers reduce blood pressure by:

1. Decreasing cardiac output
2. Inhibiting the release of the renin thus decreasing angiotensin and aldosterone effects
3. Decreasing the central vasomotor activity
4. Decreasing norepinephrine from sympathetic neurons (see the chapter Beta-Blockers)
5. These agents reduce cardiac ejection velocity and hydrodynamic stress at arterial branching points and this may prevent arterial injury that leads to atherosclerosis

Commonly used beta-blockers are included in the following sections.

a. Propranolol (Inderal)

This beta-blocker has been used since 1964 and is well known to most physicians. The drug is metabolized in

TABLE 6
Generic and Trade Names of Diuretics

Generic name	Trade name	Tablets (mg)	Usual maintenance (mg daily)
Group I: Thiazides			
Hydrochlorothiazide	HydroDiuril, Hydrosaluric, Esidrix, Esidrex oretic, Direma	25, 50, 100	25–50
Bendrofluazide	Aprinox, Berkozide, Centyl, Neo-Naclex	2.5, 5	2.5–5
Bendoflumethiazide	Naturetin	2.5, 5, 10	2.5–10
Benzthiazide	Aquatag, Exna, Hydrex	50	50–100
Cyclothiazide	Anhydron	2	2
Hydroflumethiazide	Diucardin, Hydrenox, Saluron	50	50
Chlorthalidone	Hygroton	25, 50, 100	50
Methylclothiazide	Enduron, aquatensin, Diutensin	5	2.5–5
Polythiazide	Renese, Nephрил	1, 2, 4	2–4
Trichlormethiazide	Naqua, Metahydrin	2, 4	2–4
Cyclopenthiazide	Navidrex, Navidrix	0.5	0.5–1
Metolazone	Zaroxolyn, Metenix	2.5, 5, 10	2.5–5
Quinethazone	Aquamox, Hydromox	50	50–100
Indapamide	Lozide, Lozol	2.5	2.5
Group II: loop diuretics			
Furosemide	Lasix, Dryptal	20, 40, 80	40–80
Frusemide	Frusetic, Frusid	500	
Ethacrynic acid	Edecrin	25, 50	50–150
Bumetanide	Burinex, Bumex	0.5, 1, 5	1–2
Group III: Potassium-sparing diuretics			
Spironolactone	Aldactone	25, 50 (UK), 100	50–100
Triamterene	Dyrenium, Dytac	50, 100	50–100
Amiloride	Midamor	5	5–10
Group IV: Combination I and III			
Thiazide and potassium-sparing	Aldactazide, Dyazide, Moduretic (Moduret)		

the liver. It is strongly fat-soluble and therefore has a high concentration in the brain. This may be the reason for occasional weakness and fatigue, the very rare occurrence of depression, and vivid dreams. A dosage of 40-mg tablets is used twice daily and can be increased to 80 mg twice daily. Long-acting 80- or 160-mg capsules are available for once-daily use. Propranolol is the prototype of all the newer beta-blockers, and there are really only subtle differences; however, smoking decreases the effectiveness of the drug.

b. Acebutolol (Sectral, Monitan)

This beta-blocker has few side effects. It does not decrease HDL cholesterol levels or slow the pulse rate. A dosage of 200–400 mg once or twice daily is effective and is not altered by smoking.

c. Atenolol (Tenormin)

Atenolol is totally excreted by the kidney and, because of a long half-life, it is given as a once-daily tablet, 25–100 mg. It is different from propranolol and nadolol in that it is “cardioselective,” i.e., it works mainly on the heart with only minimal effect on the lungs. Atenolol is therefore safer for patients with bronchitis provided that the dose is kept at a moderate level. If you have bronchitis, however, it is best to avoid beta-blockers. Atenolol and long-acting propranolol and nadolol have been shown to effectively reduce ambulatory blood pressure for up to 28 h after the last dose. The effectiveness of atenolol, acebutolol, and timolol are not modified by smoking.

Atenolol has not been shown to cause a decrease in cardiac mortality in RCTs. The drug does not provide cardioprotection as observed with bisoprolol, carvedilol, metoprolol, propranolol and timolol. *Beta blockers have*

subtle and important differences which have not been recognized by senior researchers. Atenolol should not be used in hypertensive drug trials that compare it with other antihypertensive agents. The author's opinion has been supported by a recent review. Carlberg *et al.* systematically reviewed the effect of atenolol on cardiovascular morbidity and mortality in hypertensive patients. Only randomized controlled trials that assessed the effect of atenolol on cardiovascular morbidity or mortality in patients with primary hypertension were included. The superiority of atenolol over placebo or no treatment in reducing blood pressure did not result in a beneficial effect on mortality or myocardial infarction. The analysis casts doubts on atenolol as a suitable first-line drug for hypertensive patients. *Moreover, it challenges the use of atenolol as a reference drug in outcome trials in hypertension.*

d. Bisoprolol (Zebeta; Monacor)

This is a cardioselective beta-blocker that is excreted partially by the kidney and the liver. It has a low side effect profile and a long duration of action and can be given 5–10 to 15 mg once daily.

e. Carvedilol (Coreg)

Dosage: 12.5–25 mg twice daily.

This beta-1 beta-2 agent has added vasodilator properties which have shown to improve survival in patients with heart failure and in patients following a myocardial infarction.

f. Metoprolol (Toprol XL)

Dosage: 50–200 mg daily.

Metoprolol is similar to atenolol in that it is also cardioselective at low doses. It is a very popular beta-blocker and is used worldwide. This drug is given twice daily. Other features of the drug are similar to propranolol, but there are fewer side effects. A long-acting tablet, Toprol XL, can be taken once daily and constitutes a major advance.

g. Nadolol (Corgard)

Dosage: 20–120 mg daily.

Nadolol is similar to propranolol except that it is not metabolized in the liver and is excreted by the kidney. Because of its long half-life in the body, it is given as a one-a-day tablet. Insomnia and vivid dreams occur

much less frequently with nadolol and atenolol compared with propranolol and metoprolol. The drug's effectiveness is not affected by smoking.

h. Pindolol

Pindolol does not cause adverse changes in blood lipids like some beta-blockers. This drug may not decrease blood pressure in hypertensives during sleep, however. The drug causes significant insomnia, disordered sleep patterns, and in a few patients, nervousness, muscle cramps, and joint pains. Pindolol has a stimulant effect because it contains beta-agonist activity, which destroys the cardioprotective properties of beta blockade. Because of this, pindolol is no longer recommended.

i. Timolol

This drug is six times more potent than propranolol, so for a given dose, a better blood level is achieved with less variation. The drug must be taken as 5- or 10-mg tablets twice daily. Because of its potency and lack of anesthetic property, timolol is used as eye drops for the treatment of glaucoma. Smoking does not appear to decrease the drug's effectiveness.

Advice and Adverse Effects of Beta-Blockers: Beta-blockers should not be given to patients with bronchial asthma, severe allergic rhinitis, Raynaud's phenomenon, and second or complete heart block. These drugs produce slowing of the heart rate, but this is a desired effect and a reduction to 50 beats per minute is acceptable. Rarely the pulse may drop to less than 48 beats per minute, and if accompanied by dizziness and low blood pressure, the dose must be reduced or the drug discontinued. Fortunately, the latter effect is uncommon, judging from the millions of individuals who are taking beta-blockers. Slowing of the pulse occurs to a lesser degree with acebutolol. It may cause fatigue, and rarely mild depression. Reduction of libido and impotence are also fortunately rare. Do not stop the drug suddenly. This withdrawal phenomenon is important only if the patient has angina or severe heart disease and is not significant in patients with hypertension alone.

Beta-blockers reduce blood pressure and slow the heart rate. They reduce the work of the heart, therefore, preventing heart failure in virtually all hypertensives except the very few in whom the heart muscle is already severely weakened. A weak heart muscle may exist in patients who have had several heart attacks or who have severe heart valve problems. Such patients usually have low blood pressure because of the severity of heart disease.

The patient's past history makes it easy for the doctor to conclude that the heart muscle is weak, and this can be confirmed by the examination of the heart, the chest x-ray, and the ECG. It is important to emphasize that large clinical trials of hypertensives utilizing beta-blockers do not show an increased incidence of heart failure.

Clinical trials with timolol, propranolol, and other beta-blockers in patients who have had heart attacks and were followed for two years showed that these drugs do not cause an increased incidence of heart failure. If patients are carefully selected by physicians, heart failure is not usually precipitated by beta-blockers. Beta-blockers have been shown recently to benefit patients who have a mild or moderate degree of heart failure. This group of drugs is relatively safe and extremely important in the treatment of hypertension, angina, heart attacks, and arrhythmias. They have recently been shown to improve survival and prevent hospitalizations in patients with heart failure.

2. Diuretics

There is no question about the efficacy of diuretics in mild-to-moderate hypertension, and when combined with other antihypertensive agents they can be used in all types and degrees of hypertension. The generic and trade names and maintenance dosage of diuretics are given in the chapter Diuretics.

a. Hydrochlorothiazide

Hydrochlorothiazide is an example of a large group of widely used diuretics called "thiazides."

Supplied: Tablets: 25 mg, 50 mg.

Dosage: Commence with 25 mg each morning and keep this dose as maintenance; maximum dose is 50 mg daily. The blood pressure-lowering effect is related to:

- Decreased blood volume; patients who have an expansion of their blood volume especially due to sodium and water retention have the maximum benefit
- Increased excretion of sodium and water by the kidney
- Mild dilatation of arteries, thereby causing a decrease in total vascular resistance

Contraindications include hypersensitivity to thiazides or sulfonamides (sulfurs), severe kidney failure, pregnant women and nursing mothers, and patients taking lithium.

A decrease in blood potassium does occur in a significant number of patients receiving thiazides, and this is a potential danger. Diuretics also cause attacks of gout. These drugs cause an increase in blood levels of uric acid, and urate crystals precipitate in joints, which causes

sudden severe pain in the joint of the big toe or ankle. The joint becomes very hot, red, and swollen. Some individuals are very susceptible to small doses of diuretics and frequent attacks of gouty arthritis occur. A course of colchicine or indomethacin relieves the painful gout in two to three days and the patient is advised to switch to another antihypertensive drug.

Some doctors add a drug called allopurinol to the diuretics to reduce the levels of uric acid, and this is given for several years. It makes more sense to stop the diuretics. The addition of allopurinol is a prime example of "polypharmacy," which adds to the handful of pills that patients are expected to take. It also adds to side effects and cost.

b. Furosemide (Lasix)

Furosemide is a powerful diuretic and is not recommended for hypertension except when associated with kidney failure. In this situation it is much more effective than thiazides.

c. Dyazide

Dyazide is a combination of 25 mg of hydrochlorothiazide and 50 mg of triamterene. The latter causes retention of potassium so there is no need to take extra orange juice or foods with a high-potassium content.

d. Moduretic (Moduret in Canada)

Moduretic is a potassium-retaining drug and contains 50 mg of hydrochlorothiazide and 5 mg of the potassium retainer amiloride. A half tablet is to be taken once daily.

Dyazide and Moduretic are relatively safe when kidney function is normal; if kidney function is impaired such that the serum creatinine is greater than 1.3 mg/dl (115 $\mu\text{mol/L}$), these drugs may retain too much potassium. High potassium in the blood may also occur if potassium-sparing diuretics are used concomitantly with ACE inhibitors or angiotensin receptor blockers. These drugs are widely used in the management of hypertension and heart failure, and prevent the patient from having to take unpleasant tasting potassium chloride mixtures. Diuretics such as Dyazide that contain triamterene should be avoided in patients who are being treated for arthritis with indomethacin, and should not be given to patients who have had a renal stone. Moduretic and Dyazide should be avoided in elderly diabetics and in patients taking an ACE inhibitor.

Eplerenone (Inspra)

Eplerenone is an aldosterone antagonist similar to spironolactone but considerably more selective with a very low affinity for progesterone and androgen receptors; thus, gynecomastia and sexual dysfunction which occur commonly with aldosterone is rarely seen with eplerenone administration.

In the EPHEsus study reported by Pitt et al., eplerenone, a selective aldosterone blocker, in patients with left ventricular dysfunction after myocardial infarction proved beneficial. Patients were randomly assigned: 3313 to eplerenone, 25 mg daily to a maximum of 50 mg or placebo and 3319 patients in addition to optimal medical therapy.

Results: During a mean follow up of 16 months, there were 478 deaths in the eplerenone group and 554 deaths in the placebo group ($P=0.008$). Cardiovascular deaths were 407 in the eplerenone group and 483 in the placebo group ($P=0.005$). The rate of death from cardiovascular causes or hospitalization for cardiovascular events, was reduced by eplerenone ($P=0.002$), as was death from any cause or any hospitalization ($P=0.02$). The rate of sudden cardiac death was significantly reduced ($P=0.03$). This drug is not advisable in patients with a serum creatinine of >1.1 mg/dl because hyperkalemia may be precipitated.

Carr et al. assessed eplerenone using ambulatory and clinical blood pressure in patients with systemic hypertension. Ambulatory and clinical blood pressures were reduced significantly. The top effective dose in stage 1–3 hypertension is 50–100 mg daily. The blood pressure lowering effect is similar to that obtained with thiazide diuretics, ACE inhibitors, calcium antagonists, and beta-blockers. Eplerenone is a welcome addition to our antihypertensive armamentarium.

3. ACE Inhibitors

ACE inhibitors are useful antihypertensive agents, but careful patient selection is necessary prior to commencement of therapy. They prevent left ventricular enlargement, hypertrophy, and heart failure and do not cause fatigue. Impotence is rare.

a. Captopril (Capoten)

This is the first ACE inhibitor introduced into medical practice for the management of hypertension during the early 1980s.

Supplied: Tablets: 12.5 mg, 25 mg, 50 mg, and 100 mg.

Dosage: 12.5 mg twice daily one hour before meals. If there is no major fall in blood pressure, the drug is

increased to 25 mg three times daily to a maximum of 50 mg three times daily. A daily dose of 75 mg appears to be as effective as higher doses. It is advisable not to exceed 50 mg three times daily. If mild kidney failure is present, the drug is given only once or twice daily because it is excreted by the kidney and can be retained in excess in the body. These agents must not be used in patients with severe kidney failure, because too much potassium may be retained.

Captopril blocks the formation of an enzyme, angiotensin-converting enzyme (ACE), which normally converts angiotensin I to angiotensin II. Angiotensin II causes powerful constriction of arteries and increases blood pressure; when the enzyme (ACE) is blocked, blood pressure falls.

Advice and Adverse Effects: ACE inhibitors carry the rare risk of life-threatening angioedema that can produce swelling of the tongue and difficulty with breathing. Although this occurrence is rare, 0.2% of patients treated, the physician must warn the patient to seek assistance in the emergency room if there is swelling of the lips, eyelids, or tongue. This reaction can occur within days and even up to two years from commencement of the medication. Deaths have occurred, albeit rarely. Mild hypertension is not a serious disease and many patients tolerate the effects for more than 30 years before developing complications. Thus, agents that are potentially harmful must be used only when other drugs are ineffective or not tolerated.

Captopril and other ACE inhibitors must not be taken along with potassium supplements or potassium-sparing diuretics such as Moduretic or Dyazide, because they all cause a retention of potassium by the kidney. Cough is a common side effect of all ACE inhibitors. The drug rarely causes a reduction in white blood cells, loss of taste, and itching.

b. Enalapril (Vasotec)

Dosage: 5–30 mg once daily. Adverse effects are similar to captopril and other ACE inhibitors.

c. Ramipril (Altace)

Dosage: This long-acting agent is given once daily. 5 mg once daily increasing to 10 mg to maximum 15 mg once daily. The effect of ramipril is similar to captopril.

See the chapter Angiotensin-Converting Enzyme Inhibitors/Angiotensin Receptor Blockers for other ACE inhibitors and for the angiotensin II receptor blockers: candesartan, eprosartan, irbesartan, losartan, telmisartan, and valsartan.

4. Calcium Antagonists/Calcium Blockers

These agents decrease the inflow of calcium into the muscle wall of arteries. A decrease in calcium within the muscle cell causes the muscle to relax, thereby producing dilatation of the artery and decrease in blood pressure. The level of calcium in the blood is not affected because the calcium is blocked only in the wall of the artery. Because these agents block channels in the cell wall that take calcium into the cell, they are also called calcium channel blockers.

Unlike other antihypertensive agents, calcium antagonists are effective in individuals at all ages and are even more effective in patients over age 65. Calcium antagonists do not cause the life-threatening angioedema that is rarely observed with ACE inhibitors.

The calcium antagonist nifedipine (Adalat) has been widely used since 1982. Other calcium antagonists include amlodipine, diltiazem (Cardizem), and verapamil (Isoptin). Verapamil slows the pulse rate and should not be combined with a beta-blocker, except in special situations.

a. Nifedipine (Adalat XL, Procardia XL)

Supplied: Tablets: 30 mg, 60 mg, 90 mg.

Dosage: One tablet taken once daily is sufficient to lower blood pressure over a 24-h period. The usual dosage is 30 mg once daily, if needed 60 mg, rarely 90 mg daily.

Adalat XL and Procardia are slow-release preparations that have proven superior to the older formulation, nifedipine capsules, which are used only in emergencies to rapidly reduce very high blood pressure.

This drug is very effective when combined with a beta-blocker. Thus a small dose of both drugs is often highly effective and has less adverse effects. Often physicians increase the dosage of a drug to levels that are advised by the manufacturer and adverse effects may occur. The combination of a small dose of two drugs is often better than a large dose of one.

Advice and Adverse Effects: Side effects include headaches, flushing, palpitations, dizziness, and swelling of the feet in 5–10 percent of patients.

b. Amlodipine (Norvasc)

Dosage: 5–10 mg once daily.

The actions and effects of amlodipine are similar to that of nifedipine and other dihydropyridine calcium antagonists. This drug has a long duration of action. Edema occurs in approximately 10% of patients.

c. Diltiazem (Cardizem, Tiazac)

Supplied: Tablets: 30 mg, 60 mg, or Cardizem CD 120 mg, 240 mg, and 300 mg.

Dosage: Cardizem CD 120 mg once daily increasing if needed to 240 mg, maximum 300 mg.

Advice and Adverse Effects: Adverse effects include mild flushing, rarely swelling of the feet, constipation, and slowing of the pulse rate.

d. Verapamil (Isoptin)

Supplied: Tablets: Isoptin SR 120 mg, 180 mg, and 240 mg.

Dosage: 120 mg daily increasing to 240 mg if needed.

Advice and Adverse Effects: Constipation occurs in approximately 15% of patients and is worse in the elderly. A slow pulse rate can occur.

5. New Calcium Antagonists

Lercanidipine, lacidipine, and manidipine are the newest category of long-acting dihydropyridines. These agents have strong membrane binding and slow release to calcium channels. The slow onset of action has important consequences regarding the relative freedom from typical dihydropyridine side effects which include tachycardia, palpitations, flushing, and edema that are significantly reduced with these new agents. Because these newer agents dilate both afferent and efferent arterioles, the high incidence of peripheral edema caused by older calcium antagonists is reduced more than 50%. The balanced effect of lercanidipine and manidipine on efferent and afferent arterioles is important in renal protection. The older calcium antagonists listed above dilate only afferent arterioles. The COHORT study in elderly, hypertensive patients concluded that lercanidipine and lacidipine are much better tolerated than amlodipine.

Recent investigations indicate that lercanidipine administered to hypertensive diabetic patients is more effective than the angiotensin receptor blocker, losartan, in reducing left ventricular hypertrophy and left ventricular mass.

These third generation dihydropyridines represent an important addition to the therapeutic armamentarium. Their place in clinical practice will increase further if they are shown to be devoid of the major adverse effect of all calcium antagonists — the precipitation of heart failure in patients with significant left ventricular dysfunction.

6. Other Vasodilators

a. Hydralazine

Supplied: Tablets: 10 mg, 25 mg, and 50 mg.

Dosage: 25–50 mg three times daily.

Advice and Adverse Effects: This drug was used extensively from 1960 to 1966. It fell from popularity in 1968 mainly because it produced significant side effects such as an arthritis-like illness (systemic lupus erythematosus), dizziness, postural fall in blood pressure, and palpitations (tachycardia) and precipitation of angina in patients with coronary heart disease.

This drug is relatively ineffective when used alone, although it is effective when combined with a diuretic and is even more effective when a beta-blocker is added in a triple combination. Hydralazine is contraindicated in patients with angina and aneurysms. Oral therapy is recommended only when other regimens fail. This drug is useful for controlling excessively high blood pressure in pregnancy just prior to delivery. It is contraindicated in the first six months of pregnancy.

7. Alpha-Blockers

a. Prazosin

Supplied: Capsules: 0.5 mg, 1 mg, 2 mg, and 5 mg (U.S.). Tablets: 1 mg, 2 mg, and 5 mg (UK and Canada).

Dosage: For mild hypertension, start with 0.5 mg test dose at bedtime. If there is no weak spell (syncope) or other adverse effects 12 h later, then it is safe to take 0.5–1 mg twice daily for a week then progress to three times daily.

The average suggested maintenance dose is 2 mg three times daily for mild hypertension and 5 mg three times daily for moderate hypertension.

A dose greater than 6 mg daily often causes an increase in heart rate and at this point the physician very often combines the drug with a beta-blocker, which decreases heart rate and further improves blood pressure control.

Prazosin blocks alpha receptors in the walls of the arteries. Alpha receptors in the artery wall, when stimulated, cause constriction of the artery. By blocking these receptors, prazosin causes the artery to dilate. The drug is thus a vasodilator.

Advice and Adverse Effects: An unadvisable increase in heart rate is common. In this respect, the vasodilator drugs, by expanding the arteries, cause a fall in blood pressure similar to that of bleeding the patient. This produces a reflex stimulation of the heart and an increase

in heart rate. With hydralazine, palpitations may occur in 25% of patients and with prazosin, 5%. However, more than 20% of patients with either drug will have an increase in heart rate.

b. Terazosin

This alpha-blocker has actions similar to prazosin and is best used in combination with a beta-blocking agent. This reduces the tachycardia and increased cardiac ejection velocity caused by the alpha-blockers. These agents are not recommended for treatment of hypertension except when other agents cannot be used because of adverse effects. *Alpha-blockers have been shown to increase the incidence of heart failure in patients with hypertension and in patients with left ventricle dysfunction and their use should be curtailed.*

8. Drugs that Act Centrally in the Brain

a. Clonidine

Supplied: Tablets: 0.1 mg and 0.2 mg.

Dosage: 0.1 mg at bedtime and then increased to twice daily, with the larger dose at night. Maintenance dose is 0.2–0.8 mg per day. Impulses or discharges originate in the brain (sympathetic impulses) and reach the arteries and cause them to constrict, therefore elevating blood pressure. Clonidine prevents these discharges or impulses from leaving the brain.

Advice and Adverse Effects: Clonidine is contraindicated in patients with depression. Drowsiness is increased by alcohol and tranquilizers. Dryness of the mouth is common, and dry eyes may also occur. A severe increase in blood pressure (rebound hypertension) can occur if the drug is discontinued suddenly. This drug is rarely recommended.

b. Methyldopa

Supplied: Tablets: 125 mg, 250 mg, and 500 mg.

Dosage: 250 mg twice daily increasing over days or weeks to 250 mg three times daily; 500 mg twice or three times daily.

It is postulated that the action of tachycardia caused by alpha-blockers such as methyldopa is central in the brain, decreasing sympathetic impulse outflow.

Advice and Adverse Effects: Methyldopa should rarely, if ever, be used without diuretics, because it causes significant sodium and water retention. This drug is an effective antihypertensive agent when combined with a diuretic. Because of the potential side effects, methyldopa

is now reserved for treatment of moderate and severe hypertension in combination with other agents that fail to achieve control. It is contraindicated with active liver disease or depression. This has been known to cause a mild hemolytic anemia, so blood counts are necessary from time to time. If the drug is stopped suddenly, the blood pressure often increases over the next 12 h to very high levels (rebound hypertension); therefore, discontinue the drug gradually. If the dose is increased too rapidly, a sudden drop in blood pressure resulting in dizziness or a fainting spell may occur. Other adverse effects include dizziness, sedation, and sexual dysfunction. Methyldopa has been used successfully for more than 25 years to treat pregnancy-induced hypertension. It has an important role in this setting because other agents except beta-blockers are contraindicated.

9. New Agent

a. Aliskiren [renin inhibitor]

Gradman, *et al.* clinical trial; The antihypertensive effect of aliskiren, the first in a new class of orally effective, nonpeptide, low-molecular-weight renin inhibitors for the treatment of hypertension was compared with the ARB irbesartan.

Methods: The study was a randomized, multicenter, double-blind, placebo-controlled, active-comparator 8-week trial in patients with mean sitting diastolic blood pressure [DBP] ≥ 95 and <110 mm Hg. After a 2-week, single-blind placebo run-in, 652 patients were randomized to receive double-blind treatment with once-daily oral doses of aliskiren (150, 300, or 600 mg), irbesartan 150 mg, or placebo.

Results: Aliskiren 150, 300, and 600 mg lowered both trough mean sitting DBP and systolic blood pressure (SBP) ($P < 0.001$ versus placebo for both variables). The effect of aliskiren 150 mg was comparable to that of irbesartan 150 mg (8.9 ± 0.7 and 12.5 ± 1.2 mm Hg).

Aliskiren 300 and 600 mg lowered mean sitting DBP significantly more than irbesartan 150 mg ($P < 0.05$). Aliskiren showed safety and tolerability comparable to those of placebo and irbesartan, with a similar incidence of adverse events.

BIBLIOGRAPHY

- ALLHAT: Officers and Coordinators for the ALLHAT Collaborative Research Group. *JAMA*, 283:1967–1975, 2000.
- ALLHAT: The Antihypertensive and Lipid-Lowering Treatment to Prevent Heart Attack Trial. Major outcomes in high-risk hypertensive patients randomized to angiotensin-converting enzyme inhibitor or calcium channel blocker vs. diuretic.
- Black, M.D., H. R., Elliott, M.D., Ph.D., W. J., Grandits, G., Anders, Pharm.D., J., for the CONVINCENCE Research Group et al. Principal results of the controlled onset verapamil investigation of cardiovascular end points (CONVINCE) trial. *JAMA*, 289:2073–2082, 2003.
- Blood Pressure Lowering Treatment Trialists Collaboration. Effects of different blood pressure lowering regimens on major cardiovascular events: Results of prospectively-designed overviews of randomized trials. *Lancet*, 362:1527–1535, 2003.
- Campbell, D. J. How should I combine beta blockers, ACE inhibitors and ARBs in the management of heart failure? JNC 7. The Seventh Report of the joint national committee on prevention detection evaluation and treatment of high blood pressure. NIH, *NHLBI*, May 2003.
- Carlberg, B., Samuelsson, O., Lindholm, L. H. et al. In hypertension: Is it a wise choice? *Lancet*, 364:1684–89, 2004.
- Carr, W. B., Krause, S., Jordan, R. et al. Assessment of the novel aldosterone blocker eplerenone using ambulatory and clinical blood pressure in patients with systemic hypertension. *Am. J. Cardiol.*, 92:38–42, 2003.
- Chobanian, MD, A. V., Bakris, G. L. and the National High Blood Pressure Education Program Coordinating Committee et al. The seventh report of the Joint National Committee on prevention, detection, evaluation, and treatment of high blood pressure: The JNC 7 Report. *JAMA*, 289:2560–2571, 2003.
- Cominacini, L., Pasini, A. F., Garbin, U. et al. Nebivolol and its 4-keto derivative increase nitric oxide in endothelial cells by reducing its oxidative inactivation. *J. Am. Coll. Cardiol.*, 42: Issue 10, 1838–1844, 2003.
- Crow, R. S., Prineas, R. J., Routaharju, P. et al. Relation between electrocardiography and echocardiography for left ventricular mass in mild systemic hypertension (Results from Treatment of Mild Hypertension Study). *Am. J. Cardiol.*, 75:1233, 1995.
- Felson, D. T., Slutskis, D., Anderson, J. J. et al. Thiazide diuretics and the risk of hip fracture: Results from the Framingham Study. *JAMA*, 265:370, 1991.
- Franco, V., Oparil, S., and Carreter, O. Hypertensive therapy: Part I. *Circulation*, 109:2953–2958, 2004.
- Franklin, S. S., Pio, J. R., Wong, N. D. et al. Predictors of new-onset diastolic and systolic hypertension: The Framingham heart study. *Circulation*, 111:1121–1127, 2005.
- Furberg, C. D., Psaty, B. M., Meyer, J. V. et al. Nifedipine: Dose-related increase in mortality in patients with coronary heart disease. *Circulation*, 92:1326, 1995.
- Giannoccaro, P. J., Wallace, G. J., Higginson, L. A. J. et al. Fatal angioedema associated with enalapril. *Can. J. Cardiol.*, 5:335, 1989.
- Gradman, A. H., Schmieder, R. E., Lins, R. L. et al. Aliskiren, a novel orally effective renin inhibitor, provides dose-dependent antihypertensive efficacy and placebo-like tolerability in hypertensive patients. *Circulation*, 111:1012–1018, 2005.
- Grossman, E., Messerli, F. H., Curr, J. R. et al. The management of hypertensive crisis. *J. Am. Coll. Cardiol.*, Jan–Feb, 1999.
- Hanson, M. W., Feldman, J. M., Beam, C. A. et al. Iodine 131-labeled metaiodobenzylguanidine scintigraphy and biochemical analyses in suspected pheochromocytoma. *Arch. Intern. Med.*, 151:1397, 1991.
- ALLHAT: Officers and Coordinators for the ALLHAT Collaborative Research Group. *JAMA*, 288:2981–2997, 2002. ALLHAT: The Antihypertensive and Lipid-Lowering Treatment to Prevent Heart Attack Trial. Major cardiovascular events in hypertensive patients randomized to doxazosin vs. chlorthalidone. The ALLHAT

- Hartman, R. P., Kawashima, A., King, F. et al. Evaluation of renal causes of hypertension. *Radiol Clin North America*, 41:909, 2003.
- Heagerty, A. M. et al. Influence of changes of blood pressure on vascular angiotensin II receptor subtype expression. *Circulation*, 111:956–957, 2005.
- Hermida, R. C., Ayala, D. E., Calvo, C., et al. Aspirin administered at bedtime, but not on awakening, has an effect on ambulatory blood pressure in hypertensive patients. *J. Am. Coll. Cardiol.*, 46: 975–983, 2005.
- Kario, K., Pickering, T. G., Umeda, Y. et al. Morning surge in blood pressure as a predictor of silent and clinical cerebrovascular disease in elderly hypertensives: A prospective study. *Circulation*, 107:1401–1406, 2003.
- Khan, M. Gabriel Hypertension. *Cardiac Drug Therapy*, sixth edition. W. B. Saunders, Philadelphia, 2003.
- Lakshman, M. R., Reda, D. J., Materson, B. J. for the Department of Veterans Affairs Cooperative Study Group on Antihypertensive Agents et al. Diuretics and beta-blockers do not have adverse effects at 1 year on plasma lipid and lipoprotein profiles in men with hypertension. *Arch. Intern. Med.*, 159:551–558, 1999.
- Lenders, J. W. M., Eisenhofer, G., Mannelli, M., et al. Pheochromocytoma. *Lancet*, 366: 665–675, 2005.
- Lucas, M. J., Leveno, K. J., Cunningham, F. G. et al. A comparison of magnesium sulfate with phenytoin: For the prevention of eclampsia. *N. Engl. J. Med.*, 333:201, 1995.
- Lunde, H., Hedner, T., Samuelsson, O. et al. Dyspnoea, asthma, and bronchospasm in relation to treatment with angiotensin converting enzyme inhibitors. *BMJ*, 308:18, 1994.
- Materson, B. J., Reda, D. J., Cushman, W. C. et al. Single drug therapy for hypertension in men: A comparison of six antihypertensive agents with placebo. *N. Engl. J. Med.*, 328:914, 1993.
- Mattioli, A. V., Zennaro, M., Bonatti, S. et al. Regression of left ventricular hypertrophy and improvement of diastolic function in hypertensive patients treated with telmisartan. *Int. J. Cardiol.*, 97: Issue 3, 383–388, 2004.
- Messerli, F. Evolution of the calcium antagonists: Past, present, and future. *Clin. Cardiol.*, 26: (Suppl. 11), 1112-11-16, 2003.
- Nissen, S. E., Tuzcu, E. M., Libby, P. for the CAMELOT Investigators et al. Effect of antihypertensive agents on cardiovascular events in patients with coronary disease and normal blood pressure: The CAMELOT Study: A randomized controlled trial. *JAMA*, 292: 2217–2225, 2004.
- Panacek, E. A., Bednarzyk, E. M., Dunbar, L. M. et al. Randomized prospective trial of fenoldopam versus sodium nitroprusside in the treatment of acute severe hypertension. *Acad. Emergency Medicine*, 2:959, 1995.
- Pearson, A. C., Pasierski, T., Labovitz, A. J. et al. Left ventricular hypertrophy: Diagnosis, prognosis and management. *Am. Heart J.*, 121:148, 1991.
- Pitt, B., Reichek, N., Willenbrock, R. et al. Effects of eplerenone, enalapril, and eplerenone/enalapril in patients with essential hypertension and left ventricular hypertrophy: The 4E-left ventricular hypertrophy study. *Circulation*, 108:1831–1838, 2003.
- Pitt, B., Remme, W., Zannad, F. et al. Eplerenone post-acute myocardial infarction heart failure efficacy and survival study investigators: Eplerenone, a selective aldosterone blocker, in patients with left ventricular dysfunction after myocardial infarction. *N. Engl. J. Med.*, 348:1309–1321, 2003.
- Pitt, B., Reichek, N., Willenbrock, R. et al. Effects of eplerenone, enalapril, and eplerenone/enalapril in patients with essential hypertension and left ventricular hypertrophy (EPHESUS): The 4E-Left Ventricular Hypertrophy Study. *Circulation*, 108:1831, 2003.
- Salathe, M., Weiss, P., Ritz, R. et al. Rapid reversal of heart failure in a patient with pheochromocytoma and catecholamine-induced cardiomyopathy who was treated with captopril. *Br. Heart J.*, 68:527, 1992.
- SHEP Cooperative Study Group et al. Prevention of stroke by antihypertensive drug treatment in older persons with isolated systolic hypertension: Final results of the Systolic Hypertension in the Elderly Programs (SHEP). *JAMA*, 265:3255, 1991.
- Slater, E. E., Merrill, D. D., Guess, H. A. et al. Clinical profile of angioedema associated with angiotensin converting enzyme inhibition. *JAMA*, 260:967, 1988.
- UK Prospective Diabetes Study Group et al. Efficacy of atenolol and captopril in reducing risk of microvascular and macrovascular complications in type II diabetes: UKPDS. *BMJ*, 317:713, 1998.
- Verberk, W. J., Kroon, A. A., Kessels, A. G. H., et al. Home blood pressure measurement: A systematic review. *J. Am. Coll. Cardiol.*, 46: 743–751, 2005.
- Verdecchia, P., Angeli, F. et al. Natural history of hypertension subtypes. *Circulation*, 111:1094–1096, 2005.
- Wassertheil-Smoller, S., Blafox, D., Oberman, A. et al. Effect of anti-hypertensives on sexual function and quality of life: The TAIM Study. *Ann. Intern. Med.*, 114:613, 1991.
- Wilkstrand, J., Warnold, I., Tuomilhto, J. et al. Metoprolol versus thiazide diuretics in hypertension. Morbidity results from the MAPHY Study. *Hypertension*, 17:579, 1991.
- Wood, S. M., Mann, R. D., Rawlins, M. D. et al. Angioedema and urticaria associated with angiotensin converting enzyme inhibitors. *BMJ*, 294:91, 1987.
- Yusuf, S., Gerstein, H., Hoogwerf, B. for the HOPE Study Investigators et al. Ramipril and the development of diabetes. *JAMA*, 286: 1882–1885, 2001.

Hypertrophy of the Heart

- I. Pathophysiology
- II. Causes and Complications of Heart Hypertrophy
- III. Diagnosis
- IV. Prevention and Management

Such an increase may depend upon enlargement of the individual cells — hypertrophy proper — or they may be at the proliferation of the cells (hyperplasia) at the same time; the two conditions are often present together.

GLOSSARY

- afterload** arterial impedance, restriction to blood flow delivered from the left ventricle; force against which the myocardium contracts in systole; a major determinant of wall stress.
- arrhythmia** general term for an irregularity or rapidity of the heartbeat, an abnormal heart rhythm.
- cardiomyopathy** heart muscle disease.
- concentric hypertrophy** diffuse generalized thickening of the myocardium with little or no change in dimensions of the left ventricular cavity as seen in pressure overload of the left ventricle.
- eccentric hypertrophy** hypertrophy with concomitant enlargement or dilatation of the ventricular cavity, as seen in volume overload of the left ventricle.
- heart failure** failure of the heart to pump sufficient blood from the chambers into the aorta; inadequate supply of blood reaches organs and tissues.
- myocardial infarction** death of an area of heart muscle due to blockage of a coronary artery by blood and atheroma; medical term for a heart attack or coronary thrombosis.
- sarcomere** the contractile unit of a myofibril; sarcomeres are repeating units, delimited by the Z bands, along the length of a myofibril that make up the myocardium of the heart.
- sudden cardiac death** death from cardiac causes that occurs instantaneously or within the hour of the onset of symptoms; the hallmark features are an instantaneous and unexpected time and mode of cardiac death.

NUMEROUS STUDIES HAVE DOCUMENTED A strong relationship between hypertrophy of the heart and the risk of serious cardiac events. Hypertrophy is an increase of the essential tissue of an organ, for example, the muscle cells of the heart or of the biceps in a bodybuilder.

I. PATHOPHYSIOLOGY

Physiologic, naturally occurring hypertrophy usually represents as an adaptation to increased functional demands, and a similar principle dominates pathologic hypertrophy. Hypertrophy of the heart affects the left ventricle and left ventricular hypertrophy is a feature of many forms of heart disease. The left atrium may, however, hypertrophy to assist a left ventricle that is under stress and strain imposed by pressure or volume overload. The right ventricle may hypertrophy in patients with pulmonary artery hypertension or pulmonary valve stenosis. The right atrium may hypertrophy to assist the right ventricle and also be hypertrophied in patients with chronic obstructive pulmonary disease.

A. Compensatory Hypertrophy

Compensatory hypertrophy occurs in response to abnormal functional demands imposed on the heart and the processes are similar to the physiologic adaptation described above. The heart muscle is capable of great hypertrophy when its workload is increased — such as when it has to pump against a pressure overload (systolic overload) — as may occur with obstruction to the aortic valve, aortic stenosis, or with chronic sustained hypertension. Hypertension is the most common cause of left ventricular hypertrophy.

In hypertrophy of the heart the muscular wall becomes greatly thickened, and the weight of the heart may be twice normal or even more. The muscle fibers are increased in thickness and length, and enlargement of the individual fibers causes an increase in muscle mass. There is evidence that division of muscle cells occurs, but this hyperplasia is subsidiary.

Reactive hypertrophy of the heart muscle may occur when myocardial muscle is lost. This is seen following a myocardial infarction. This situation also occurs with damage to the muscle caused by various cardiomyopathies. As muscle hypertrophy increases, the tension in the ventricular wall is amplified. This enhances hypertrophy of surviving myocytes and the following biochemical and pathophysiologic adaptations occur.

1. The rate of contraction of the myocardium decreases, the time to achieve peak tension is delayed and relaxation is slowed.
2. A slower myosin isoenzyme is synthesized to replace the normal faster isoenzyme.
3. The reaction of the myocardium to increased pressure overload or afterload is to contract more forcefully but more slowly.
4. Volume overload of the ventricles occurs typically with significant mitral regurgitation, aortic regurgitation, and large ventricular septal defects.

The biochemical and pathophysiologic processes that engage in hypertrophy can be observed within hours when the heart is subjected to acute pressure overload. It appears that the increased afterload stimulates myocardial hypertrophy by replication of sarcomeres in parallel. The sarcomere structure looks like that of an electrostatic linear motor (see Fig. 2 in the chapter Athlete and Sudden Cardiac Death).

The increase in myocardial mass occurs to compensate for the decreased contractility of the heart muscle that is subjected to pressure overload. The exact biochemical, neural, hormonal, or other pathophysiologic signal is unknown, but it is related to the chronic increase in systolic ventricular wall tension. Severe obstruction to the aortic valve or, aortic stenosis, is a typical pressure overload situation. Over time the hypertrophy of the ventricle takes place in a concentric fashion; there is thickening of the entire left ventricle wall which includes the interventricular septum. There is no increase in size of the left ventricle cavity, however. Concentric hypertrophy improves systolic wall tension and a strong heart muscle may pump for longer than expected.

In volume overload conditions there is an increase in preload, defined as the degree of ventricular muscle stretch present at the onset of myocardial contraction. This is often expressed as end diastolic volume or pressure. Volume overload causes the left ventricular wall and the ventricular chamber to increase in size proportionately, and this type of hypertrophy is termed eccentric hypertrophy. There is both hypertrophy and dilatation of the ventricular cavity as opposed to concentric hypertrophy in which the muscle mass increases but the ventricular cavity

is not dilated or enlarged. The chronic increase in diastolic wall stress causes the production of additional sarcomeres predominantly in series. Preload, however, also increases systolic wall stress and replication of sarcomeres in parallel takes place and provides some normalization of systolic stress.

The ventricular cavity expands to accommodate the large volume of regurgitant blood flow and this protects the ventricle from marked elevation of diastolic pressure. The heart is able to sustain this type of workload for several years before heart failure occurs. The molecular mechanism of hypertrophy, however, remains unclear. Myocardial stretch is recognized as playing an important role.

B. Angiotensin II

Myocardial wall stretch stimulates the renin angiotensin aldosterone system (RAAS). Angiotensin II has been shown to stimulate growth factors, cytokines, fibroblast activity, myocyte hypertrophy, and myocardial fibrosis. The relative prevention of activation of the heart RAAS by angiotensin-converting enzyme (ACE) inhibitors and more recently by angiotensin receptor blockers has provided important additions to the armamentarium available to prevent hypertrophy and/or cause regression. Other agents that favorably influence the RAAS include the weak diuretic spironolactone and a similar agent, eplerenone, which has less adverse effects. Beta-adrenergic blocking drugs also decrease renin activity and complement the blockade of RAAS achieved with ACE inhibitors plus eplerenone.

Although it is recognized that angiotensin II provides an important mechanism for left ventricular hypertrophy, it appears that it is not the most important mechanism. Harada et al., in angiotensin II type 1a receptor knock-out mice were not able to prevent development of hypertrophy. The signaling processes that underlie the causes of myocardial hypertrophy require clarification which may provide new therapeutic strategies to prevent or ameliorate hypertrophy.

C. RNA

An important factor accounting for growth of the heart when it has to work against an increased pressure load is an increased concentration of RNA within the heart. The levels of RNA in the heart are elevated within 1–3 days following the burden of a high workload. Increased capacity for synthesis is a major determinant for the provision of increased cardiac mass. After a rapid growth phase is over, RNA concentrations return to normal levels.

It is unclear whether the increase in RNA concentration is due to faster synthesis or to reduce RNA degradation. Stretch of the ventricular wall seems to be the mechanical determinant for the maintenance of the efficiency of synthesis and accelerated formation of new ribosomes.

D. Mitochondria Mass and Function

A decrease in the mass of mitochondria relative to the mass of myofibrils occurs in experimental hypertrophy. There may be defects in mitochondrial oxidative phosphorylation and in mitochondrial calcium metabolism that could later lead to myocardial muscle failure.

E. Other Factors

I. Myosin and Myofibrillar ATPase

During hypertrophic processes there is decreased activity of myofibrillar and myosin adenosine triphosphatase which may explain alterations in contractile velocity.

2. Connective Tissue

The loss of cardiac myocytes stimulates hypertrophy of existing myocytes, but it is always accompanied by a variable replacement with collagen and other connective tissue elements. Connective tissue is good supporting tissue, but its tensile strength is poor compared to that of myocardial muscle. It also has no contractile properties. Marked replacement with collagen is seen in hypertrophic as well as in other cardiomyopathies. Patchy and extensive replacement of contractile myocardium with collagen causes weakening of the ventricular muscle. Ventricular systolic and diastolic dysfunction results in and leads to heart failure, which is a common feature of dilated cardiomyopathies (see the chapter Cardiomyopathy). Following a myocardial infarction or myocarditis some patchy replacement of necrotic myocytes by collagen and fibrous tissue occurs.

II. CAUSES AND COMPLICATIONS OF HEART HYPERTROPHY

A. Causes

Cardiac hypertrophy can be caused by the following processes.

1. Pressure overload due to clinical conditions such as aortic stenosis, hypertension, pulmonary stenosis, coarctation of aorta
2. Volume overload due to clinical conditions such as mitral valve regurgitation, aortic valve regurgitation, large ventricular septal defects, and patent ductus arteriosus
3. Reactive processes that may occur following obstruction to myocardial cells such as with myocardial infarction, myocarditis, dilated cardiomyopathy, and other causes of myocardial cell loss
4. Diseases that primarily affect the myocardial muscle such as hypertrophic cardiomyopathy (see Figure 1 in the chapter entitled cardiomyopathy)
5. Physiologic hypertrophy as seen in athletes (see the chapter Athletes and Sudden Cardiac Death).

B. Complications

Left ventricular hypertrophy is associated with a significant increase in the incidence of heart failure, myocardial infarction, arrhythmias, and sudden death. In the presence of left ventricular hypertrophy, the left atrium tries to pick up some of the stretch to aid the ventricle. The thin-walled weak chamber has very little to offer except that fibrosis occurs during the course of left atrial hypertrophy and with alterations the conducting tissue which culminates in atrial fibrillation. Chronic hypertension that persists without adequate treatment for more than 10 years is a common cause of mild left atrial hypertrophy and atrial fibrillation, which slowly predispose a patient to cardiac embolization to the brain causing stroke. Massive hypertrophy (>30 mm) in patients with cardiomyopathy is associated with sudden death.

III. DIAGNOSIS

The diagnosis of left ventricular hypertrophy and left atrial hypertrophy are readily made from electrocardiographic findings. Figure 1 shows a normal ECG Figs. 2 and 3 show features of left ventricular hypertrophy.

- The sum of the S wave in V1 (or V2) + the R wave in V5 (or V6) is 40 mm (normal is less than 35 mm; in the normal tracing, Fig. 1, the sum is less than 30 mm).
- ST segment depression and T-wave inversion in leads V5 and V6 (left ventricular strain pattern).
- Left atrial hypertrophy.

The electrocardiogram, however, may not detect mild hypertrophy. Echocardiography is much more expensive but more specific and sensitive for ventricular hypertrophy than the electrocardiogram. An expensive MRI test is rarely required, but is extremely useful in differentiating

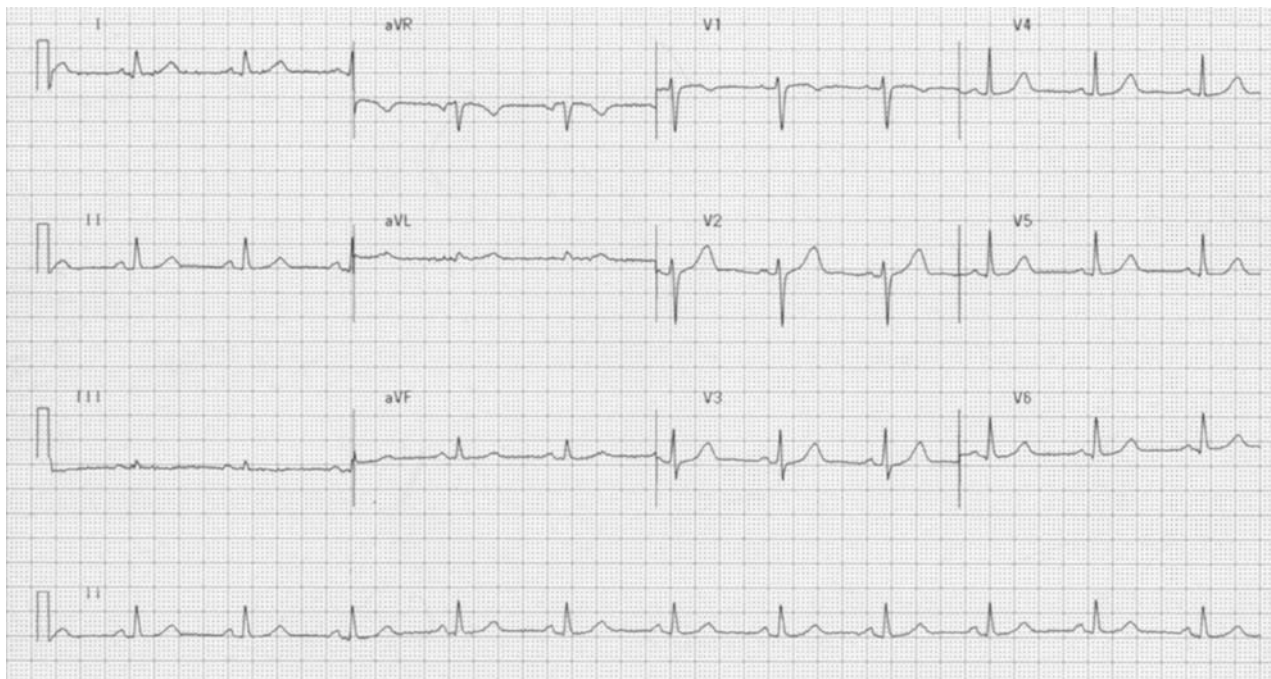

FIGURE 1 A normal ECG. Note the sum of the S wave in V1 (or V2), + the S wave in V5 (or V6) is 30 mm, normal is less than 35 mm. There is no deformity of the ST-T segment.

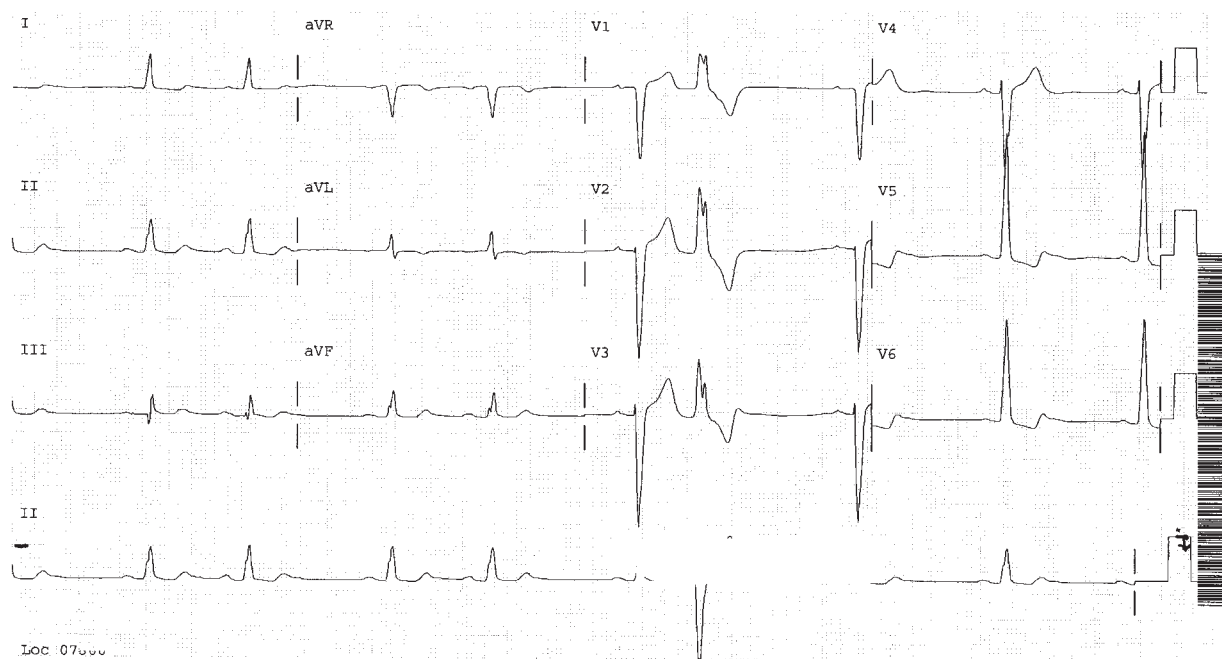

FIGURE 2 Note the deep S waves in V1 and V2 and tall R waves in V5 and V6. Also note the deformity of the ST-T wave in V5 to V6 (left ventricular strain pattern).

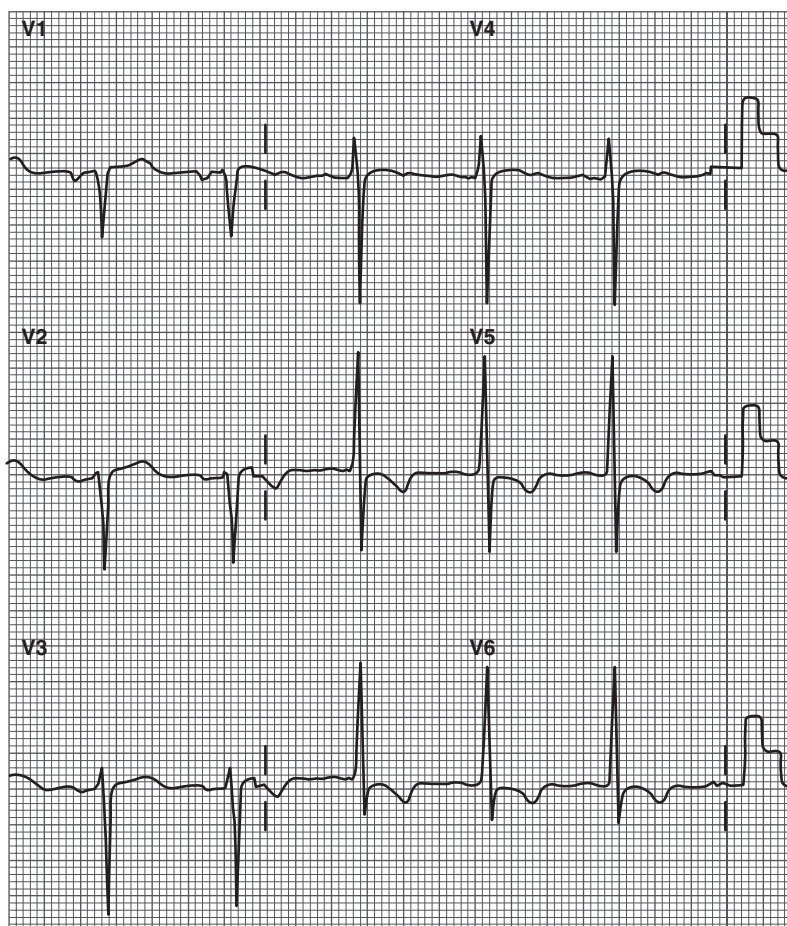

FIGURE 3 Note the standardization is at half voltage in V1 through V6 (thus the S waves are twice as deep and the R waves in V5 and V6 are twice as tall, the sum being greater than 40 mm). ST-T abnormality in V5-V6 (strain pattern), lead V1 shows left atrial hypertrophy, which occurs early in the development of left ventricular hypertrophy. (From Khan, M. Gabriel *Rapid ECG Interpretation*, second edition, W. B. Saunders, Philadelphia, 2003).

physiologic hypertrophy found in well-trained athletes as opposed to pathologic hypertrophy found in hypertrophic cardiomyopathy (see Figure 1 in the chapter Athletes and Sudden Cardiac Death).

A. Clinical study: Verdecchia et al.

Study question: A prospective observational multicenter investigation was done because only a few single-centered studies support the prognostic value of elevated left ventricular mass in uncomplicated hypertension. The prespecified aim was to explore the prognostic value of left ventricular mass in hypertension.

Methods: Admission criteria included essential hypertension, and no previous cardiovascular events revealed on echocardiographic tracings. Then 1033 individuals (396

men) were followed for a median of 3 years. Their mean blood pressure was 154/92, and left ventricular mass greater than 125 g per body surface area.

Results: Left ventricular hypertrophy was associated with increased risk of cardiac events. For each 39 g/m² increase in left ventricular mass there was an independent 40% rise in the risk of major cardiovascular events ($p=0.0013$).

Conclusions: The findings showed a strong continuous and independent relationship of left ventricular mass to subsequent cardiovascular morbidity.

IV. PREVENTION AND MANAGEMENT

Hypertension is the main cause of left ventricular hypertrophy and aggressive treatment of hypertension

can prevent it. Some antihypertensive agents are, however, not effective in preventing hypertrophy. With some agents the blood pressure may be lowered but hypertrophy may not be arrested and may not show regression.

A. Alpha-Blockers

Alpha-1 receptor adrenergic blockers include prazosin, terazosin, and doxazosin. Several clinical studies have shown that these agents do not prevent hypertrophy, and in some instances they have shown an insignificant increase in left ventricular mass. The reason for their lack of effectiveness is probably related to the fact they stimulate the heart and increase ejection velocity as well as heart rate. This calls for more effort because the heart has to work harder. In addition, these agents increase norepinephrine levels that stimulate the sympathetic nervous system. They also cause sodium and water retention as well as increased incidence of heart failure. The ALLHAT study indicated that these agents increase morbidity and mortality due to heart failure in hypertensive patients and they are no longer recommended. These agents were widely used for the management of hypertension from 1970 to 2001 because they do cause a lowering of blood pressure and do not have deleterious effects on blood lipid levels. They are still prescribed by specialists who give them to diabetic patients because they do not raise blood lipid levels.

B. ACE Inhibitors

These agents have been shown to be effective in preventing hypertrophy and cause regression. Similar agents such as angiotensin II receptor blockers are just as effective. Blockade of angiotensin II by inhibition of its formation by an ACE inhibitor or by blockade of the effects of angiotensin I at the AT1 receptor has favorable effects on left ventricular hypertrophy. But these agents also inhibit the formation of aldosterone, which increases hypertrophy.

C. Beta-Adrenergic Blockers

These agents have been shown to decrease left ventricular hypertrophy but effects appear to be modest when compared with ACE inhibitors. Nonetheless, these drugs are cardioprotective and strongly advisable for use in a combination of a beta-blockers to prevent hypertrophy, produce regression, and prevent cardiac events. Both beta-blockers and ACE inhibitors have been proven independently to reduce the risk of serious cardiac events. An appropriate beta-blocker should be chosen, however,

because subtle and important differences exist among the available beta-blockers. Bisoprolol, carvedilol, and metoprolol (Toprol) are more effective agents than other beta-blockers and have proven cardioprotective effects documented by randomized controlled trials.

D. Calcium Antagonists

Calcium antagonists and calcium channel blockers include amlodipine, felodipine, and nifedipine. These agents cause excellent lowering of blood pressure but have not consistently shown beneficial effects regarding prevention of left ventricular or its regression.

An excellent study by Gottdiener et al. on 587 patients treated with single agents and left ventricular hypertrophy studied by echocardiography showed that ACE inhibitors were most effective followed by hydrochlorothiazide rather than atenolol. Atenolol is not a good beta-blocker for a trial, however, because it has never been shown to be cardioprotective in randomized clinical trials. Clonidine, prazosin, and diltiazem (a calcium antagonist) showed no change or insignificant increases in left ventricle mass.

E. Diuretics

Diuretics commonly used include hydrochlorothiazide and chlorthalidone. These agents have been shown to cause modest reduction in left ventricular hypertrophy and regression in some studies, but other studies have shown negative effects.

F. Aldosterone Receptor Blocking Agents

a. Spironolactone

Aldosterone is produced by the adrenal cortex under the influence of renin and angiotensin and has been shown to cause ventricular hypertrophy and myocardial fibrosis. Fibrosis causes weakness of the muscle and also produces abnormal relaxation of the left ventricle and left ventricular diastolic dysfunction. This hormone appears to block extraneuronal uptake of norepinephrine from the myocardium and may augment cardiac failure and increased risk of sudden cardiac death that is associated with activation of the RAAS and left and hypertrophy. ACE inhibitors and angiotensin II blockers inhibit angiotensin production and actions that finally suppress aldosterone, but the suppression is far from complete. Even a combination of ACE inhibitors and angiotensin II receptor blockers has failed to completely suppress aldosterone production.

b. Eplerenone (Inspra)

Because spironolactone causes gynecomastia and other mild adverse effects, new aldosterone receptor blockers are being sought. A new compound, eplerenone, does not have the same side effects as spironolactone. Eplerenone was developed by replacing the 17 alpha-thiacetyl group of spironolactone with a carbomethoxy group. The drug is devoid of sex hormonal effects of spironolactone because it has a greater selectivity for the mineralo-corticoid receptor than for steroid receptors.

Pitt *et al.* have shown that 200 mg of eplerenone daily was as effective as enalapril in controlling BP and in obtaining LVH regression. The combination of eplerenone and enalapril was more effective in reducing LV mass and SBP than eplerenone alone.

Dosage. 50–200 mg once daily. Hyperkalemia may occur when used concomitantly with ACE inhibitors, ARBS, or potassium-retaining agents.

BIBLIOGRAPHY

Carlberg, B., Samuelsson, O., Lindholm, L. H. et al. In hypertension: Is it a wise choice? *Lancet*, 364:1684–89, 2004.

- Devereux, R. B. Do antihypertensive drugs differ in their ability to regress left ventricular hypertrophy? *Circulation*, 95:1983–85, 1997.
- Gottdiener, J. S., Reda, D. J., Massie, B. M. et al. For the VA Corporative Study group on antihypertensive agents. Effects of single drug therapy on reduction of left ventricular mass in mild to moderate hypertension: Comparison of six antihypertensive agents. *Circulation*, 95:2007–14, 1997.
- Harda, K., Komuro, I., Shiojima, I. et al. Pressure overload induces cardiac hypertrophy in angiotensin II type Ia receptor knock-out mice. *Circulation*, 97:1952–1959, 1998.
- Mattioli, A. V., Zennaro, M., Bonatti, S. et al. Regression of left ventricular hypertrophy and improvement of diastolic function in hypertensive patients treated with telmisartan. *Int. J. Cardiol.*, 97: Issue 3, 383–388, 2004.
- Pitt, B. Regression of left ventricular hypertrophy in patients with hypertension. Blockade of the renin angiotensin aldosterone system. *Circulation*, 98:1987–89, 1998.
- Pitt, B., Reichek, N., Willenbrock, R. et al. Effects of eplerenone, enalapril, and eplerenone/enalapril in patients with essential hypertension and left ventricular hypertrophy: The 4E-left ventricular hypertrophy study. *Circulation*, 108:1831–1838, 2003.
- Pitt, B., Remme, W., Zannad, F. et al. Eplerenone post-acute myocardial infarction heart failure efficacy and survival study investigators: Eplerenone, a selective aldosterone blocker, in patients with left ventricular dysfunction after myocardial infarction. *N. Engl. J. Med.*, 348:1309–1321, 2003.
- Verdecchia, P., Carini, G., Circo, A. et al. Left ventricular mass and cardiovascular morbidity in essential hypertension: The MAVI study. *J. Am. Coll. Cardiol.*, 38:1829–35, 2001.

Kawasaki Heart Disease

- I. Clinical Features
- II. Diagnosis
- III. Causation
- IV. Management

GLOSSARY

arterial dilatation enlargement or increase in luminal diameter of the artery.

myocardial infarction death of an area of heart muscle due to blockage of a coronary artery by blood clot and atheroma; medical term for a heart attack or coronary thrombosis.

vasculitis inflammation of the walls of a blood vessel.

KAWASAKI DESCRIBED THIS ILLNESS IN Japanese children in 1967. The major cardiac lesion is an inflammatory reaction of the walls of arteries or vasculitis of the coronary arteries. A similar disease is polyarteritis nodosa. The exact cause of the disease is unknown. It is seen worldwide, however; in Japan children with a mean age of 12 months are affected and in the United States the mean age is closer to 3 years. Kawasaki heart disease is rare in children over the age of 8 with more than 85% being younger than 5 years. Children younger than 6 months or older than 8 years are rarely affected; but the older group is at increased risk of coronary-artery aneurysms. The reported annual incidence rate in Japan is approximately 140 per 100,000 children under 5 years of age versus 17 and 8 in the US and UK, respectively.

Rheumatic fever caused by streptococcal sore throats was a common occurrence in children in developed countries prior to 1970. The disease is still common in nonindustrialized countries. In Japan and the western world Kawasaki disease is now a more common cause of acquired heart disease in young children than acute rheumatic fever.

I. CLINICAL FEATURES

This disorder is virtually always accompanied by fever for more than 5 days. The fever has no identifiable cause

(fever of unknown origin) and occurs without the common manifestation of an upper respiratory tract viral infection or flu-like illness. The diagnosis is entertained if fever of unknown origin is accompanied by at least four of the following:

1. Bilateral conjunctival redness, injection
2. Inflamed throat, redness of the tongue (strawberry tongue), fissuring of the lips
3. Redness of the palms and soles of the feet, swelling, edema of the hands and feet
4. Body rash
5. Enlargement of lymph nodes around neck (cervical lymphadenopathy).

Because these features are much more common in the Far East, the condition is recognized as part of a mucocutaneous lymph node syndrome. The cardiac part of this syndrome is now widely referred to as Kawasaki disease.

Other symptoms are not necessary for the diagnostic conclusions including joint pains, diarrhea, vomiting, bowel pain, and aseptic meningitis. The disease may be confused with and must be distinguished from the following:

1. Streptococcal sore throat and streptococcal infections
2. Staphylococcal toxin-mediated illness
3. Viral infections such as adenovirus, enterovirus, and measles
4. Allergic reactions to various medications and household products
5. Myocarditis.

II. DIAGNOSIS

Diagnosis is difficult and infants with three or more of the above symptoms with unexplained fever for more than 2 weeks should have an echocardiographic evaluation to exclude coronary artery aneurysms. Damage to the coronary arteries by vasculitis occurs in more than 25% of infants and in about 10% of children age 2–5. Coronary

artery aneurysm and thrombosis may cause myocardial infarction and sudden death. Similar aneurysms may be found in the worst affected cases in the renal, cerebral, and abdominal arteries. Children frequently died during the acute phase of Kawasaki disease, but if they recover they may present with symptoms of aneurysms during adolescence and rupture of an aneurysm may cause sudden death. Coronary-artery aneurysms occur as a sequela of the vasculitis in 20–25% of untreated children. The syndrome may remain silent until the third or fourth decade of life, when patients are present with an acute myocardial infarction. Cardiac complications include myocarditis, pericarditis with effusion; mitral valvular lesions occur in about 1% of patients.

Nonspecific findings include anemia, increasing white blood cell count, sediment rate and C-reactive protein, and mild elevation of liver enzymes. The electrocardiogram may show nonspecific ST-T wave changes caused by myocarditis.

III. CAUSATION

The cause of Kawasaki syndrome remains unknown; an infectious agent is suspected because of the following

- Seasonal peak in the winter and spring months in most geographic areas.
- Geographic focal epidemics occurred in the 1970s and 1980s.

Burns *et al.*, point out that “peak incidence in the toddler age-group with only rare cases in infants under 3 months of age and in adults suggests a role for transplacental antibodies conferring protection and development of protective immunity as a result of asymptomatic infection in most individuals.” Burns *et al.*, suggest that “Research should focus on unique features of the vasculitis that might serve as a diagnostic test, even if the underlying cause remains unknown.”

Kawasaki syndrome and polyarteritis nodosa possess similarities and essential differences:

- Coronary artery aneurysms occur in about 20% of children with kawasaki and in less than 1% with polyarteritis nodosa.
- The pattern of inflammation in Kawasaki reveals infiltration of CD8-positive T cells and macrophage and few polymorphonuclear cells with prominent edema without fibrinoid necrosis versus prominent fibronoid necrosis, a hallmark of polyarteritis nodosa.

IV. MANAGEMENT

A. Intravenous Gamma Globulin Therapy

Coronary artery abnormalities such as aneurysm and thrombosis are reduced by treatment with intravenous gamma globulin 2 g/kg in a single infusion over 10–22 hours given within the first 10 days of illness. But more than 5% of children treated develop dilatation of the coronary arteries and in ~1% giant aneurysms develop. Intravenous therapy is repeated if there is occurrence of fever for more than 48 h.

B. Aspirin

The anti-inflammatory actions of moderate doses of aspirin are useful in controlling fever, then the dose is reduced to approximately 5 mg/kg/day for 8 weeks. This small dose inhibits platelet aggregation and may prevent thrombosis. Treatment with aspirin does not prevent formation of aneurysms. During the assumed recovery phase, coronary artery vasculitis may precipitate myocardial infarction.

C. Corticosteroids

Some studies indicate that the use of steroids prevents the occurrence of coronary artery aneurysms. As with other conditions that cause vasculitis, corticosteroids appear to quench the fiery stage but they are not curative.

Antithrombotic agents and occasionally coronary artery bypass graft is required to treat Kawasaki disease. Further research is required to uncover the etiologic process of this disease and its pathogenesis in order to develop logical therapeutic strategies.

BIBLIOGRAPHY

- Burns, J. C. et al. Translation of Dr. Tomisaku Kawasaki's original report of fifty patients in 1967. *Pediatr. Infect. Dis. J.*, 21:993–95, 2002.
- Burns, J. C., Glodé, M.P. et al. Kawasaki syndrome: Seminar. *Lancet*, 364:533–44, 2004.
- Burns, J. C., Shike, H., Gordon, J. B., Malhotra, A., Schoenwetter, M., Kawasaki, T. et al. Sequelae of Kawasaki disease in adolescents and young adults. *J. Am. Coll. Cardiol.*, 28:253–57, 1996.
- Dajani, A. S., Taubert, K. A., Gerber, M. A. et al. Diagnosis and therapy of contrast at the disease in children. *Circulation*, 87:1776, 1993.
- Kato, H., Inoue, O., Kawasaki, T., Fujiwara, H., Watanabe, T., Toshima, H. et al. Adult coronary artery disease probably due to childhood Kawasaki disease. *Lancet*, 340:1127–29, 1992.

- Kawasaki, T., Kosaki, F., Okawa, S. et al. A new infantile acute febrile mucocutaneous lymph node syndrome (MCLS) prevailing in Japan. *Pediatrics*, 54:271–76, 1974.
- Kawasaki, T. et al. Pediatric acute mucocutaneous lymph node syndrome: Clinical observation of 50 cases. *Averugi (Jpn. J. Allergy)*, 16:178–222, 1967.
- Kushner, H. I., Bastian, J. F., Turner, C. L., Burns, J. C. et al. Rethinking the boundaries of Kawasaki disease. *Perspect. Biol. Med.*, 46:216–33, 2003.
- Landing, B. H., Larson, E. J. et al. Are infantile periarteritis nodosa with coronary artery involvement and fatal mucocutaneous lymph node syndrome the same? Comparison of 20 patients from North America with patients from Hawaii and Japan. *Pediatrics*, 59:651–62, 1976.
- Mitani, Y., Sawada, H., Hayakawa, H., Auki, K. et al. Elevated levels of high-sensitivity C-reactive protein and serum amyloid-A late after Kawasaki disease: Association between inflammation and late coronary sequelae in Kawasaki Disease. *Circulation*, 111:38–43, 2005.
- Moran, A. M., Newburger, J. W., Saunders, S. P. et al. Abnormal myocardial mechanics in Kawasaki syndrome. Rapid response to gamma globulin. *Am. Heart J.*, 139:217–23, 2000.
- Newburger, J. W., Takahashi, M., Burns, J. C. et al. Treatment of Kawasaki syndrome with intravenous gamma globulin. *N. Engl. J. Med.*, 315:341–47, 1986.
- Newburger, J. W., Takahashi, M., Gerber, M. A. et al. Diagnosis, treatment, and long-term management of Kawasaki disease: A statement for health professionals from the Committee on Rheumatic Fever, Endocarditis and Kawasaki Disease, Council on Cardiovascular Disease in the Young, American Heart Association. *Circulation*, 110: 2747–2771, 2004.
- Wu, M. T., Hsieh, K.S., Lin, C. C. et al. Evaluation of coronary artery aneurysms in Kawasaki disease by multislice computed tomographic coronary angiography. *Circulation*, 110:e339, d, 2004.

Miscellaneous Disorders

- I. Marfan Syndrome
- II. Cor Pulmonale
- III. Ehlers-Danlos Syndrome
- IV. Noonan Syndrome
- V. Ebstein's Anomaly
- VI. Turner Syndrome
- VII. Fetal Alcohol Syndrome
- VIII. Holt-Oram Syndrome
- IX. Paget's Disease
- X. Ankylosing Spondylitis
- XI. Rubella Syndrome
- XII. Pseudoxanthoma Elasticum
- XIII. Myotonic Muscular Dystrophy
- XIV. Takayasu
- XV. Lupus Erythematosus
- XVI. Sarcoidosis
- XVII. Syphilis
- XVIII. Atrial Myxoma

I. MARFAN SYNDROME

Marfan syndrome is an autosomal dominant disorder that occurs in all races and ethnic groups. Marfan syndrome is caused by mutations in the gene that encodes fibrillin-1, the major constituent of microfibrils that forms elastic fibers in tissues of the middle wall of the aorta and arteries.

A. Diagnostic Symptoms and Physical Signs

The heart, aorta, the eye, and the skeleton show typical features that are diagnostic, but marked clinical variability and a high rate of new mutation make detection of mildly affected young sporadic patients difficult to diagnose. Thus, failure to diagnose Marfan syndrome is common.

I. Heart and Aorta

Mitral valve prolapse, dilatation of the sinuses of Valsalva, and aortic regurgitation are common findings in Marfan syndrome patients. Dilatation of the aortic root and ascending aorta leads to aneurysm formation and dissection which accounts for early mortality. The average age of death is in the fourth and fifth decades of life.

2. Eyes

The eyes show a tremulous iris typical of dislocation of the lens (ectopia lentis), myopia, and retinal detachment. Sometimes there is a blue sclera.

3. Skeleton

The skeleton shows joint hypermobility, long extremities and fingers, typical arachnodactyly (spider finger; the thumb protrudes beyond the little finger when the fist is clenched), tall stature, pectus excavatum or pectus carinatum, a high-arched palate, and scoliosis.

B. Management

Endocarditis prophylaxis is necessary as well as restriction of severe exertional activity including weightlifting and contact sports. The use of beta-adrenergic blocking drugs such as metoprolol have been shown to delay the rate of aortic dilatation and the risk of aortic dissection. Pregnancy should be avoided in individuals with an aortic diameter that exceeds 3.5 mm, because pregnancy enhances dissection in the third trimester or during parturition and the first month postpartum.

II. COR PULMONALE

Cor pulmonale describes heart disease secondary to lung diseases (pulmonary heart disease). These conditions cause severe chronic hypoxemia, which increases pulmonary

artery pressures and right ventricular workload resulting in right heart failure. Hypoxemia is a potent stimulus for vasoconstriction and pulmonary hypertension. Right heart failure is manifested by shortness of breath and easy fatigability at rest or mild activity. Heart failure causes retention of salt and water by the kidneys which leads to swelling of the legs; the legs are brine-logged and not simply waterlogged.

A. Causes

1. Chronic Bronchitis and Emphysema

The most common causes of cor pulmonale are long-severe chronic bronchitis and emphysema.

2. Chronic and Restrictive Lung Diseases

Chronic obstructive lung disease (COPD) is the most common cause of cor pulmonale. Long-standing severe chronic bronchitis and emphysema are the main causes of chronic obstructive lung disease, which leads to severe hypoxemia.

Restrictive lung diseases also are a common cause of cor pulmonale. They encompass a large group of diffuse lung diseases that show a typical filling of the alveoli and/or infiltration of the pulmonary interstitium, which results in a characteristic pattern of restrictive lung impairment with reduction in lung volumes and decrease in the compliance of the lung (see chapter entitled Pulmonary Arterial Hypertension).

These diseases include disorders of unknown cause (idiopathic pulmonary fibrosis, sarcoidosis, collagen vascular disease), infections (viral, bacterial, fungal, and parasitic), and environmental lung disease (pneumococcosis, asbestosis, silicosis, berylliosis, silo-fillers disease).

Restrictive lung disease causes severe hypoxemia which results from mismatching of ventilation and perfusion. Gas exchange is typically disturbed during exercise so restrictive lung disease limits lifestyle considerably.

B. Diagnosis

Notable findings include:

- Increased shortness of breath on minimal exertion
- Easy fatigability at rest
- Tachypnea
- Pursed lips expiration
- Paradoxical abdominal breathing and constant use of accessory muscles of respiration
- Asterixis and chemosis

- Central cyanosis with warm extremities are observed, but the occurrence of peripheral cyanosis with cold extremities indicates that right heart failure has supervened

Findings of diffuse crackles (crepitations) heard on auscultation over the lung fields. The PaO₂ is usually less than 55 mmHg when patients are free from an exacerbation of COPD. There is a reduced diffusion capacity for carbon monoxide (Dlco) in patients with restrictive lung disease and emphysema but not in those with pure chronic bronchitis. The chest x-ray may narrow the differential diagnosis when combined with a history and physical examination. High-resolution CT is often necessary to confirm radiologic findings with further confirmation by thoracoscopic lung biopsy.

C. Management

Management of patients with cor pulmonale consists of treatment of the underlying disease and correction of hypoxemia with continuous oxygen administration. A minimum of 15 h of oxygen daily to keep the PaO₂ greater than 60 mmHg may provide a modest improvement in survival and activity levels. Digoxin is indicated only if atrial fibrillation is present. Furosemide is given to relieve bothersome bilateral pitting edema at doses of 20–40 mg daily.

III. EHLERS-DANLOS SYNDROME

Various defects of type III collagen are the cause of the phenotype in all patients with Ehlers-Danlos syndrome. Both skin and joint manifestations are associated with spontaneous rupture of medium and large caliber arteries. The skin is fragile leading to skin abnormalities and the eyes may show a blue coloring of the sclerae, which is also seen with osteogenesis imperfecta.

A rupture of an artery without aneurysm formation or dissection may occur. The abdominal aorta or medium-sized branches of aorta; for example, the subclavian or large arteries of the limbs may rupture, but true aneurysms rarely form. Mitral valve prolapse occurs, but aortic root dilatation is rare.

IV. NOONAN SYNDROME

This is an autosomal dominant disorder that leads to short stature, cubitus valgus, neck webbing, congenital lymphedema, and congenital heart defects similar to that

of Turner syndrome. Both males and females are affected and manifest deformity of the sternum, mental dullness, typical hypertelorism, and drooping of the eyelid (ptosis).

Cardiac manifestations include valvular pulmonary stenosis; the valve cusps are thickened and dysplastic and a right-sided flow may be impeded by obstruction because of pulmonary artery hypoplasia. In more than one-third of patients an atrial septal defect occurs often in association with pulmonary valve stenosis.

V. EBSTEIN'S ANOMALY

This disorder is characterized by downward displacement of the tricuspid valve into the right ventricle caused by anomalous attachment of the tricuspid valve leaflets. If the tricuspid valve is severely deformed, heart failure occurs and death may result *in utero* or soon after birth. With mild deformity individuals may remain symptom-free into adulthood or beyond middle age. Associated malformations include a patent foramen ovale, an atrial septal defect, and pulmonary stenosis or atresia. An ostium primum atrial septal defect alone or combined with other defects indicates a bad prognosis. This abnormality may be associated with congenital corrected transposition of the great vessels. Adult patients present with shortness of breath and fatigue, palpitations, associated Wolff-Parkinson-White syndrome, cyanosis from a right-to-left shunt, and occasionally paradoxical embolus causing a cerebrovascular accident. Diagnosis is usually made from echocardiographic examination.

VI. TURNER SYNDROME

This anomaly is manifested in females who lack an X chromosome (45, X karyotype). Coarctation of the aorta may be seen. A bicuspid aortic valve, aortic stenosis, and dilatation of the ascending aorta with the risk of aortic dissection may occur, even in the absence of a coarctation; thus, endocarditis prophylaxis is necessary.

The body habitus includes low hairline, low-set ears, deafness, small jaw, short webbed neck, short stature, broad chest with widely spaced nipples, hypertelorism, epicanthal folds, ptosis, and a shortened fifth finger.

VII. FETAL ALCOHOL SYNDROME

Children born to alcoholic mothers may be affected with fetal alcohol syndrome. Because of maxillary hypoplasia

these individuals have an undeveloped appearing central face along with a small upturned nose (micrognathia) and thin upper lip. Common associated cardiac lesions include atrial and ventricular septal defects.

VIII. HOLT-ORAM SYNDROME

In this autosomal dominant disorder the common cardiac abnormalities are an atrial or ventricular septal defect that is associated with a characteristic fingerized thumb. The thumb resembles a finger that has been displaced into the same plane as the other digits; the thumb may be triphalangeal, hypoplastic, absent, or unusually long.

IX. PAGET'S DISEASE

Paget's disease of bone characteristically causes a large head size. Cardiovascular lesions include large arteriovenous (AV) fistulas that may cause congestive heart failure. Calcification of the aortic valve may cause a loud murmur produced by aortic sclerosis without stenosis. Calcification of the electrical conduction system may result in a slow heart rate (bradycardia), and occasionally complete heart block that may require an electronic pacemaker.

X. ANKYLOSING SPONDYLITIS

This disease of the skeleton often cause sacroilitis with a painful low back caused by a fused inflexible spine. The patient is hunched over because of an immobile curved spine with forward jutting of the head. The associated cardiac lesion is aortic regurgitation and sometimes atrio-ventricular block.

XI. RUBELLA SYNDROME

A history of maternal rubella is usually obtained. Manifestations include cataracts, nystagmus, and deafness.

XII. PSEUDOXANTHOMA ELASTICUM

In this condition the skin around the armpit (axilla), the antecubital fossa, behind the knee (popliteal fossa), the neck, and other areas becomes lax with characteristic yellowish papules. Examination of the retina with

the ophthalmoscope may reveal angioid streaks. Life-threatening gastrointestinal hemorrhage is common.

The most important cardiac lesion involves the coronary arteries, which develop a form of arteriosclerosis that may cause coronary artery occlusion resulting in myocardial infarction. Other associated cardiovascular disorders include thickened aortic and mitral valves, mitral valve prolapse, and hypertension.

The recessive and dominant forms of this disorder have been mapped to the same region of chromosome 16. Management includes control of hypertension and risk factors for atherosclerosis. Dietary calcium intake should be restricted including consumption of dairy products and avoidance of calcium supplements because of a positive association between severity of the disease and dietary calcium intake.

XIII. MYOTONIC MUSCULAR DYSTROPHY

In adults diagnostic features of myotonic muscular dystrophy include reflex, percussion, and grip myotonia. This is a characteristic inability to release after exerting a grip on an object. There is also weakness and atrophy of the skeletal muscles, premature baldness, cataracts, and mental retardation. Cardiologic involvement includes arrhythmia, intraventricular conduction defects, and complete heart block that may require electronic pacing. There is fibrosis and fatty infiltration with degeneration of the specialized electrical conduction tissue, particularly the sinus node, AV node, and Purkinje system.

XIV. TAKAYASU

This larger vessel vasculitis of unknown etiology occurs in young individuals in Asia and Mexico. In these areas Takayasu arteritis is one of the most common causes of hypertension in young adults. Women are affected about 10 times more often than men.

A. Cardiovascular Lesions

Aneurysm formation of the aortic root leads to aortic regurgitation and arterial occlusions (stenosis) of the major branches of the aorta such as the subclavian, carotid, brachiocephalic, and renal arteries. Stenosis of the renal artery causes hypertension. Occlusion of one subclavian artery results in a low blood pressure recording in that arm, and the high blood pressure that exists may not be detected if the blood pressure is not checked in both

arms. The characteristic histologic lesion is intense mononuclear leukocyte infiltration in the presence of giant cells. This pronounced intimal thickening leads to minimal residual lumen of arteries and organ ischemia (lack of blood perfusion) because of the stenotic lesions.

The mortality rate is high because of the aggressive vascular disease caused by hypertension or primary cardiac renal and central nervous system involvement. Mortality is as high as 35% at 5 years.

Symptoms are caused by lack of blood supply to organs and fatigue, night sweats, and fever may occur. Involvement of the aortic root may cause severe aortic regurgitation, angina, and congestive heart failure. The sedimentation rate is assessed, but it may be normal in up to 50% of individuals with progressive lesions.

B. Management

Corticosteroid therapy, such as prednisone 1 mg/kg daily produces beneficial results in up to 60% of patients. Prednisone combined with cyclophosphamide or methotrexate produces up to 40% remission, but relapse is common. Stenotic lesions throughout the vascular arterial system should be identified and corrected surgically if possible.

XV. LUPUS ERYTHEMATOSUS

This well-known disorder may cause rare cardiac lesions. Pericardial lesions occur in more than 30% of patients, but significant pericarditis is manifested in less than 20%. The initial manifestation of lupus erythematosus (LE) may be pericarditis, but pericardial involvement may occur at any stage of the disease. Cardiac tamponade may be caused by pericardial effusion.

Acute myocarditis is a rare complication. Arteritis of coronary arteries may cause chest pain of acute coronary syndrome and rarely results in acute myocardial infarction. Conduction abnormalities rarely cause heart block requiring a pacemaker. Arrhythmias may require antiarrhythmic therapy.

Valvular disease may occur as thickening of valve structures and vegetations (Libman-Sacks noninfective endocarditis) are rare but characteristic lesions. Vegetations are generally located on the atrial side of the mitral valve and the arterial side of the aortic valve. They are usually immobile and thus rarely embolize to cause a mini stroke. Cardiovascular complications and renal disease are the most common cause of mortality (see the chapter Blood Clots).

XVI. SARCOIDOSIS

Sarcoidosis is a well-recognized granulomatous disease that causes enlarged lymph nodes (lymphadenopathy) in the hilar region of the lung. In some individuals the disease affects the spongework of the lung (parenchyma) and causes restrictive lung disease (see Section II and the chapter Cardiomyopathy). Sarcoidosis involvement of the lung may be confused with tuberculosis, lymphoma or cancer.

The granulomatous involvement of the myocardium and conducting tissue may cause atrioventricular block and complete heart block which requires an electronic pacemaker. Sarcoidosis may cause dilated cardiomyopathy that may be difficult to distinguish from idiopathic dilated cardiomyopathy. Prednisone produces beneficial effects in some patients.

XVII. SYPHILIS

The main cardiovascular lesion caused by syphilis is an aortitis that causes aortic aneurysms, aortic regurgitation, and coronary ostial lesions. Spirochetal infection was once a common cause of aneurysm of the ascending thoracic aorta. These aneurysms cause complications including compression of the recurrent laryngeal nerve which results in hoarseness and pressure on the bronchi causes a brassy cough.

A characteristic radiologic finding is linear calcification of the ascending aorta. Syphilitic aneurysms are now a rare finding in the western world as a result of aggressive antibiotic treatment of syphilis in its early stages. The latent period from the initial syphilitic infection to significant aortic aneurysm formation is about 10–30 years. The aortic valve ring is typically severely dilated resulting in severe aortic regurgitation.

Microscopically, the vasa vasorum of the aorta are involved in an endarteritis obliterans that causes weakening

of the arterial wall and aneurysm formation. Rupture of aneurysms may rarely occur.

XVIII. ATRIAL MYXOMA

Benign primary cardiac tumors are uncommon and malignant tumors are rare. Metastatic tumors occur more often than primary tumors of the heart, but rarely cause functional disturbances. A left atrial myxoma is the most common cardiac tumor and is usually symptomatic.

Symptoms include fever, weakness, malaise, Raynaud's phenomenon, and finger clubbing. The diagnosis may be missed because of nonspecific findings. Cardiac symptoms include shortness of breath on exertion, paroxysmal nocturnal dyspnea, syncope, and palpitations. Embolization of tumor fragments may cause transient cerebral ischemia attacks or small strokes. Embolization may occur to the limbs causing limb ischemia. Multiple embolization may mimic vasculitis or infective endocarditis.

Mobile pedunculated left atrial myxomas may prolapse into the mitral valve orifice causing obstruction to blood flow that results in syncope or cardiogenic shock. Symptoms and signs may mimic mitral stenosis (see the chapter Valve Diseases). Arrhythmias such as supraventricular tachycardia, ventricular premature beats, and occasionally ventricular tachycardia may occur. The patient's sedimentation rate is usually markedly elevated and transesophageal echocardiography should be diagnostic. MRI is also helpful in confirming the diagnosis. Surgical removal of the lesion usually produces a complete cure.

BIBLIOGRAPHY

- Braunwald, E., Zipes, D. P., and Libby, P. eds. *Heart Disease*, sixth edition. W. B. Saunders, Philadelphia, 2001.
- Sutherland, E. R., and Cherniack, R. M. Management of chronic obstructive pulmonary disease. *N. Engl. J. Med.*, 350:2689–2697, 2004.

Murmurs and Heart Disease

- I. Clinical Cases
- II. Clinical Diagnosis of Heart Murmurs
- III. Investigative Tests

GLOSSARY

cardiac output the volume of blood pumped by the ventricle per unit time expressed in liters per minute; it is the function of the stroke volume multiplied by the heart rate.

heart failure failure of the heart to pump sufficient blood from the chambers into the aorta; inadequate supply of blood reaches organs and tissues.

S1 the first heart sound caused by closure of the mitral and tricuspid valves.

S2 the second heart sound caused by closure of the aortic and pulmonary valves.

A HEART MURMUR IS A SOUND (BRUIT) HEARD on auscultation with a stethoscope placed at various locations over the chest or neck vessels and over dilated arteries. Typically these sounds are periodic and of short duration. They coincide with the short systolic or diastolic timing of the heart's contraction and relaxation during which blood is ejected or the chambers are filled during systole and diastole, respectively. Heart murmurs result from disturbances of normal blood flow patterns in the heart. They are classified on the basis of their timing as systolic, diastolic, or continuous (systolic and diastolic).

The most common murmur is systolic. Systolic murmurs occur during the contraction of the ventricles. Many systolic murmurs are nonsignificant in that they may occur in individuals where no evidence of heart disease can be found and do not disturb the function of the heart. Murmurs that occur when the ventricles are relaxed, that is, during diastole, are termed diastolic murmurs and are always of significance. Murmurs are usually caused by disease of the heart valves (see the chapter Valve Diseases).

Over a period of 5–50 years, significant murmurs indicate valve disease that increase the work of the heart

muscle and cause it to enlarge. The muscle finally becomes weak and heart failure occurs (see the chapter Heart Failure). Some murmurs such as that caused by mitral stenosis prevent the chambers of the heart from filling.

I. CLINICAL CASES

A. Questions Posed

A female, age 30, posed the following questions: My family doctor says that I have a systolic murmur at the apex of the heart and referred me to a cardiologist. I would like to know:

1. What is my prognosis?
2. Is there any contraindication to using birth control pills?
3. Will the murmur affect future pregnancy and the number of children I can have?
4. When will an operation be necessary?
5. Can I prevent it from becoming worse?

B. Answers

Below are the answers to the previous questions asked.

1. A soft systolic murmur over the apex of the heart is usually of no significance. It is important, however, to identify any mild area of roughness or deformity of the valve, which can later develop an infection called endocarditis. When a doctor states that a murmur is of no significance, it means that the murmur will not affect the person's life span or activities. If you have not had rheumatic fever and there are no other murmurs and no shortness of breath, the murmur is likely due to an increased blood flow across the valve, a common finding in normal young adults and also during pregnancy. The cardiologist's findings with the stethoscope, followed by a chest x-ray and electrocardiogram, usually exclude most serious problems. If some doubt exists, an echocardiogram is helpful. Echocardiography

will document a degree of stenosis or regurgitation. Diastolic murmurs are always significant, whereas soft systolic murmurs are often not.

2. The murmur does not contraindicate the use of birth control pills.
3. The murmur will not affect your pregnancy, the fetus, or subsequent pregnancies and should not limit the number of children. If the murmur is loud and the doctor hears it over a wide area of the chest, this is a different matter and further assessment including an echocardiogram may be necessary to exclude severe mitral regurgitation.
4. An operation is never required in patients with a soft systolic murmur or mild mitral regurgitation. Surgery for mitral regurgitation is utilized only when there are symptoms of severe shortness of breath or heart enlargement and when an echocardiogram shows severe regurgitation.
5. If you have no symptoms and if the murmur is described as soft and heard over an area of less than five fingertips held together, it is most unlikely that your condition will get worse. Only infection of the valve can shorten your life. Fortunately, the risk of getting an infection on the valve is remote; when germs get into the blood, they need to stick on the valve and grow. There is a 1 in 1000 chance of this occurring, and prevention through antibiotics is the rule if the murmur is caused by a valve disease process. Antibiotics are not required for many "functional," nonsignificant murmurs (see the chapter Valve Diseases).

II. CLINICAL DIAGNOSIS OF HEART MURMURS

A. Diagnostic Clues

Usually the diagnosis is obvious from the patient's effort tolerance and the finding of a murmur with the stethoscope as well as other symptoms. A cardiologist makes the diagnosis in the office with 95% confidence in more than 90% of cases.

1. Diagnostic Points

- The timing of the murmur relative to the first heart sound, S₁, and to the second heart sound, S₂: This provides the most meaningful piece of information that fixes the timing of the murmur as systolic or diastolic. If the murmur is difficult to time, the examiner should identify S₂ of the base of the heart and move the

stethoscope down from the base to the apex fixing the cardiac cycle with S₂ as a reference point (see Figs. 1 and 2).

- The point of maximal intensity of the murmur: This should be identified, although this does not always provide information that is accurate; for example, the systolic murmur of aortic valve sclerosis and aortic stenosis may be heard best at the apex of the heart rather than at the second right interspace, the aortic area.
- The character or quality of the murmur: Assess if the murmur is high-pitched, low-pitched, rumbling, only crescendo, only decrescendo, or crescendo decrescendo (see Fig. 1). These features are typically distinctive to the trained clinician's ear. The difference between the high-pitched blowing diastolic murmur of aortic regurgita-

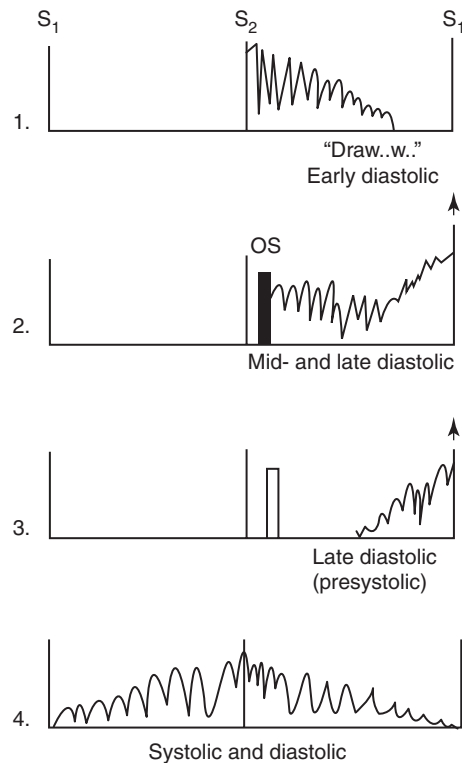

FIGURE 1 Patterns of diastolic and continuous murmurs. (1) Early diastolic murmur, high-pitched, decrescendo, maximal at the left sternal edge at the third or fourth intercostals space; typical of aortic regurgitation. Mimic by saying "Daw.w.;" the "D" replaces the S₂. (2) Mid- to late diastolic, low-pitched rumble with presystolic accentuation ending in a loud S₁; typical of mitral stenosis. OS = opening snap. (3) Late diastolic murmur, i.e., presystolic murmur ending in a loud S₁; indicates mitral stenosis. This murmur usually disappears if atrial fibrillation is present. (4) Systolic and diastolic continuous "machinery" murmur of patent ductus arteriosus; it is loudest at the time of S₂. (From Khan, M. Gabriel (2001). *On Call Cardiology*, 2nd ed., Philadelphia: W. B. Saunders, p. 39.)

tion and the rumbling very low pitched diastolic murmur of mitral stenosis is like night and day. Some aspects of murmur quality are not as distinctive, for example, harshness, rough, creaky, musical, or blowing.

- Intensity.

The intensity of a murmur is judged by six different grade levels. Murmurs are graded, for example, as 2 over 6.

- Grade 1: A very soft murmur that is faintly heard; the murmur may be missed at the initial or on subsequent examination
- Grade 2: A soft murmur that is readily heard
- Grade 3: A loud murmur with no thrill (vibrations) felt on palpation with the palm or finger pads placed over the point of maximal intensity of the murmur
- Grade 4: A loud murmur with a thrill present
- Grade 5: A very loud murmur with a thrill present that can be heard when the edge of the stethoscope is applied to the area of maximal intensity
- Grade 6: The loudest murmur heard with the stethoscope removed a centimeter off the chest wall

The intensity of systolic murmurs does not always relate to the severity of the valvular lesion. A murmur caused by severe obstruction to the aortic valve may be a soft grade 2 in patients with low cardiac output and heart failure. The intensity therefore may prove useful if the examiner considers the volume and velocity of blood flow and dilatation of the aortic root in the given individual.

B. Classification

Murmurs are classified as follows:

- Systolic: beginning after S1 and ending at all or before the aortic or pulmonary sound, S2 (see Fig. 2)
- Diastolic: beginning with S2 and ending just before S1.
- Continuous: beginning in systole and continuing through S2 into part or all of diastole; continuous murmurs are rare

I. Systolic Murmurs

Nonsignificant systolic murmurs can be heard in more than 60% of children. The systolic murmur of aortic valve sclerosis without stenosis is heard in more than 50% of individuals older than 50 years. Systolic murmurs can be classified as early systolic, midsystolic, late systolic, or holosystolic (occurring all through the systolic time interval; Fig. 2).

Midsystolic murmurs represent an important group caused by organic disease. These movements begin after

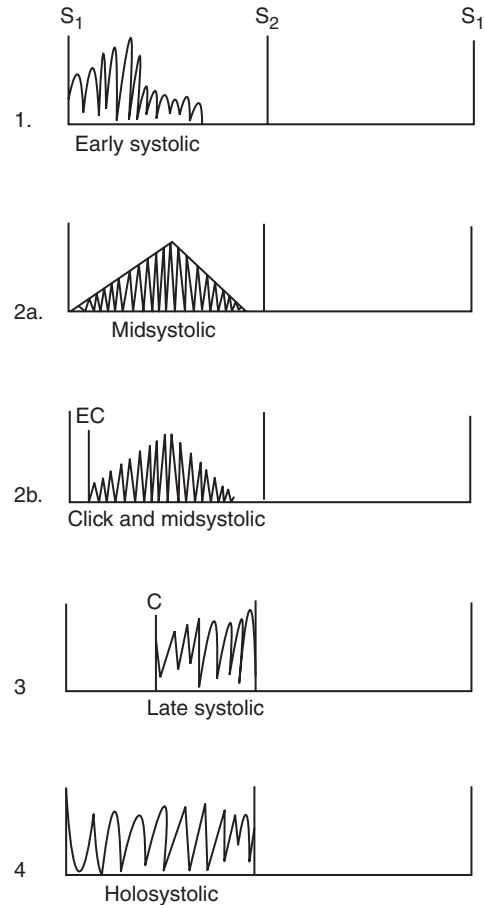

FIGURE 2 Patterns of systolic murmurs. Timing of the murmur can be diagnostic. (1) Early systolic murmur at apex and left lower sternal border caused by acute mitral or tricuspid regurgitation; by regurgitation into a normal-sized atrium; or by a very small ventricular septal defect with late shunting abolished. (2a) Midsystolic murmur at left sternal border and aortic area; is not always aortic stenosis — consider increased flow, high-output states, some forms of mitral regurgitation, and innocent murmurs. (2b) Midsystolic murmur preceded by an ejection click (EC) is typical of congenital aortic stenosis. The click is absent in rheumatic calcific stenosis or nonpliable valves. (3) Late systolic murmur typical of mitral valve prolapse (C = click); one or more clicks may be heard. (4) Holosystolic murmur typical of chronic mitral or tricuspid regurgitation or ventricular septal defect. (From Khan, M. Gabriel (2001). *On Call Cardiology*, 2nd ed., Philadelphia: W. B. Saunders, p. 44.)

S1 and end well before S2, that is, a clear gap between the end of the murmur and S2 (see Fig. 2). Midsystolic murmurs occur when there is obstruction to ventricular flow as observed with aortic or pulmonary valve stenosis.

Mid to late systolic murmurs (Fig. 2) are usually caused by mitral valve prolapse. Holosystolic murmurs begin with S1 and continue through the entire systolic interval. This murmur is caused by blood flow from a chamber or a vessel with a higher pressure and resistance

than the receiving chamber or vessel. Holosystolic murmurs are often regurgitant; a common cause is mitral regurgitation.

2. Diastolic Murmurs

These are classified as early mid or late diastolic. The most common early diastolic murmur is that caused by aortic valve regurgitation. This murmur is best heard with the diaphragm of the stethoscope firmly pressed against the mid-left sternal edge with the patient sitting up at the side of the bed with the breath held after a full exhalation. The high-pitched blowing decrescendo murmur has typical characteristics.

3. Prosthetic Valve Murmurs

Aortic mechanical valves cause turbulence that produces a grade 1 to 2 ejection systolic murmur that is of no significance. Sudden increase in the systolic murmur may reflect obstruction by thrombus. A diastolic murmur is usually abnormal and suggests a perivalvular leak. Bioprosthetic valves produce no sounds, but when they

degenerate systolic murmurs emerge. Musical murmurs in this setting suggest a tear of a leaflet.

III. INVESTIGATIVE TESTS

Chest x-ray, ECG, and echocardiogram are helpful to confirm the clinical opinion obtained from the patient's history and relevant examination. In a few individuals with serious heart murmurs causing symptoms such as severe shortness of breath with or without heart failure, cardiac catheterization tests are invaluable to corroborate the findings on echocardiography. This is often done if surgical correction is planned. The technique of catheterization is outlined in the chapter Tests for Heart Diseases, and echocardiographic diagnostic points are given in the chapter Valve Diseases.

BIBLIOGRAPHY

Khan, M. Gabriel. *On Call Cardiology*, second edition. W. B. Saunders, Philadelphia, 2001.

Nonsteroidal Anti-Inflammatory Drugs

I. Adverse Cardiovascular Effects

GLOSSARY

acute coronary syndrome this syndrome defines patients with acute chest pain caused by myocardial infarction or unstable angina.

arrhythmia general term for an irregularity or rapidity of the heartbeat, an abnormal heart rhythm.

atherosclerosis same as atheroma, raised plaques filled with cholesterol, calcium, and other substances on the inner wall of arteries that obstruct the lumen and the flow blood; the plaque of atheroma hardens the artery, hence the term atherosclerosis (sclerosis = hardening).

cardioprotection protection of the heart from serious events that include coronary artery disease and its complications, angina, myocardial infarction, and heart failure.

heart failure failure of the heart to pump sufficient blood from the chambers into the aorta; inadequate supply of blood reaches organs and tissues.

myocardial infarction death of an area of heart muscle due to blockage of a coronary artery by blood clot and atheroma; medical term for heart attack or coronary thrombosis.

CYCLOOXYGENASE (COX) OR PROSTAGLANDIN endoperoxidase H synthase inhibitors, is a major component of the rheumatologist's armamentarium. Two isoenzymes, COX-1 and COX-2, are encoded by separate genes located on different chromosomes. These isoenzymes are targets of nonselective nonsteroidal anti-inflammatory drugs (NSAIDs).

These agents are widely used for the control of pain in patients with arthritis. Because the widely used *steroidal* anti-inflammatory agents of the sixties and seventies (cortisone, prednisone) caused relief but long-term use produced serious adverse effects, nonsteroidal agents were heralded as the answer for a variety of arthritic disorders.

NSAIDs, however, cause the kidneys to retain sodium and water. This action may cause an increase in blood pressure. Also, an increase in sodium and water in the

body increases the work of the heart and can precipitate heart failure in patients with a weak heart muscle (left ventricular dysfunction). Patients may experience increased shortness of breath and swelling of the ankles. These agents are well known to cause bleeding from the stomach.

Available NSAIDs used from the seventies include carprofen, diclofenac, fenoprofen, flurbiprofen, ibuprofen, indomethacin, ketoprofen, naproxen, piroxicam, sulindac, and tolmetin. Newer agents discovered in 1989 and introduced into medical practice in the early nineties block COX-2 and are called COX-2 inhibitors. These include celecoxib, meloxicam, rofecoxib, parecoxib, and valdecoxib. It was speculated that these specific COX-2 inhibitors (selective NSAIDs) would be safer and cause less gastric bleeding than the old NSAIDs, and this is the main reason that COX-2 inhibitors are publicized as having advantages over NSAIDs.

The older agents (NSAIDs) inhibit COX-1, but the inhibition is not permanent and they partially block COX-2. In contrast, aspirin permanently and irreversibly acetylates and blocks cyclooxygenase, therefore preventing the production of platelet thromboxane A₂. The latter is a powerful platelet-aggregating agent that forms clots (thrombi). Aspirin, thus prevents platelet-derived thrombosis that is involved in the causation of myocardial infarction and stroke.

NSAIDs clearly do not have this cardioprotective benefit of the wonder drug, aspirin; (see Figure 1). Aspirin, (acetylsalicylic acid) irreversibly acetylates the enzyme cyclooxygenase, an enzyme necessary for the conversion of platelet arachidonic acid to thromboxane A₂, a powerful platelet aggregating agent and vasoconstrictor. This beneficial effect is not provided by NSAIDs or COX-2 inhibitors (see the chapter entitled Aspirin for Heart Disease) and the newer agents, unfortunately, appear to increase the risk of cardiovascular thrombotic events.

I. ADVERSE CARDIOVASCULAR EFFECTS

All NSAIDs significantly inhibit the beneficial effects of several drugs, including furosemide, hydrochlorothiazide,

other thiazide diuretics, ACE inhibitors, and angiotensin receptor blockers. Aspirin is a weak NSAID that does not cause sodium and water retention, increased blood pressure, or heart failure, but it can interfere with the effectiveness of ACE inhibitors.

Recent studies have suggested that ibuprofen may interfere with the cardioprotective effects of aspirin on the cardiovascular system. Thus, patients with cardiovascular disease who require aspirin therapy should not be using NSAIDs concomitantly.

A. Effects on Prostacyclin

Normal formation of prostacyclin (PGI₂), a vasodilator and potent platelet inhibitor, is increased mainly through COX-2. NSAIDs and COX-2 inhibitors (selective NSAIDs) block prostacyclin production in vessel walls. Prostacyclin prevents platelet aggregation and cardiac arrhythmias. It keeps the arteries dilated and the arterial walls “clean.” PGI₂ may limit the extent of platelet adhesion and activation at sites of atherothrombotic disease. COX-2 inhibitors are potent prostacyclin inhibitors and increase cardiovascular atherothrombotic events. To reemphasize, selective inhibitors of cyclooxygenase, COX-2 inhibitors depress prostacyclin but not COX-1-derived thromboxane A₂. Thus, the harmful effects of thromboxane A₂ are exaggerated by COX-2 inhibitors; this action predisposes cardiovascular patients to stroke and myocardial infarction. See Figure 1. It is not surprising, therefore, that in 2004, warnings as to dangers of COX-2 inhibitors were publicized.

Aspirin in *large* doses inhibits prostacyclin, but small beneficial doses of aspirin less than 160 mg daily inhibit thromboxane A₂ synthesis and platelet aggregation and do not significantly inhibit prostacyclin production. (see the chapter Aspirin for Heart Disease). Both selective and nonselective NSAIDs reduce prostacyclin formation in the infarcted myocardium. They accomplish this by tipping the balance of prostacyclin/thromboxane in favor of thromboxane, a prothrombotic eicosanoid. Acute myocardial ischemia increases prostacyclin and thromboxane concentrations in coronary vein blood. Thromboxane promotes platelet aggregation, causes vasoconstriction, and initiates ventricular arrhythmias.

COX-2 inhibitors have been shown to reduce prostacyclin formation in normal volunteers by up to 80%. Bing et al. have obtained evidence of changes in the prostacyclin/thromboxane ratio after celecoxib, which lowers myocardial prostacyclin production in the infarcted heart muscle but fails to inhibit thromboxane. Thus, COX-2 inhibitors tip the balance of prostacyclin/thromboxane in

favor of thromboxane; this may be responsible for increased vascular and thrombotic events.

This deleterious process may explain the unfavorable results of the Vioxx gastrointestinal outcomes research (VIGOR). In this trial of patients with rheumatoid arthritis, none of whom were allowed to be on low-dose aspirin, there was an excess of myocardial infarctions in patients on rofecoxib compared with Naprosyn. Patients who took rofecoxib at 50 mg daily had a fivefold increased risk of myocardial infarction. There was no evidence of raised risk of coronary artery disease among users of rofecoxib 25 mg or less or among users of other NSAIDs.

Investigators have postulated that the higher infarction rates probably occurred not because rofecoxib may have increased these rates, but because Naprosyn was cardioprotective. This is, however, wishful thinking. An epidemiologic study comparing high-dose rofecoxib with lower doses of rofecoxib and nonspecific NSAIDs suggested an increased risk for myocardial infarction with high doses of rofecoxib. Naprosyn and other NSAIDs have not been shown to be cardioprotective; they do not have the *permanent* antiplatelet effects of aspirin. In addition, basic research indicates that COX-2 inhibitors and the well known nonselective NSAIDs limit infarct healing.

B. Effect on Atherothrombosis

COX-2 is expressed in the monocytes and smooth muscle cells that migrate from the media into the intima which characterize atheromatous plaques (see chapter Atherosclerosis). Individuals with extensive atherothrombotic disease have enhanced formation of thromboxane A₂. COX-2 inhibitors, by preferentially suppressing prostacyclin generation and sparing thromboxane, may increase atherothrombosis. There are some data, however, that indicate that COX-2 expressed in monocytes/macrophages contributes to development of atherosclerosis in animal models. In this setting COX-2 inhibitors may be expected to prevent atheroma formation. A 30% reduction in atherosclerosis by the COX-2 inhibitor nimesulide was observed by Pratico et al. The nonselective COX inhibitors, aspirin and indomethacin, have been shown to retard the development of atherosclerosis in apoE mice to a greater extent than a selective COX-2 inhibitor.

C. Increased Viral Load

There is evidence suggesting a casual role of cytomegalovirus (CMV) in atherogenesis. CMV infection has been shown to cause progression of atherosclerosis in a murine

model of atherosclerosis. Rott et al. demonstrated that selective inhibition of COX-2 increases viral load in apoE-deficient mice. This increase in viral load was paralleled by increased anti-CMV antibody titers. Inhibition of COX-2 significantly increased early atherosclerotic lesion areas independent of viral infection.

D. Hypertension and Heart Failure

NSAIDs increase blood pressure and increase the incidence of heart failure because they cause the kidneys to retain sodium and water. COX-2 inhibitors may cause a greater elevation in the blood pressure and the incidence of heart failure. They also interact with antihypertensive agents and drugs used for the management of heart failure.

E. Caution

Caution is required with the use of selective NSAIDs in patients with coronary artery disease. These agents should be avoided in patients at risk for the development of heart failure, hypertension, or acute coronary syndromes. Antiarthritic (nonsteroidal anti-inflammatory) agents including indomethacin, ibuprofen, and piroxicam and the newer, selective nonsteroidal anti-inflammatory agents (COX-2 inhibitors) such as celecoxib, meloxicam, and rofecoxib retain salt and water in the body and commonly precipitate heart failure in patients with poor heart muscle function.

BIBLIOGRAPHY

- Belton, O., and Fitzgerald, D. Cyclooxygenase-2 inhibitors and atherosclerosis. *J. Am. Coll. Cardiol.*, 41:1820–2, 2003.
- Bing, R. J., and Lomnicka, M. Why do cyclo-oxygenase-2 inhibitors cause cardiovascular events? *J. Am. Coll. Cardiol.*, 39:521–522, 2002.
- Bresalier, MD, R. S., Sandler, MD, R. S., Quan, PhD, H. et al. Cardiovascular events associated with rofecoxib in a colorectal adenoma chemoprevention trial. *N. Engl. J. Med.*, 352:1092–1102, Number 11, March 17, 2005.
- Burleigh, M. E., Babaev, V. R., Oates, J. A. et al. Cyclooxygenase-2 promotes early atherosclerotic lesion formation in LDL receptor-deficient mice. *Circulation*, 105:18 16–23, 2002.
- Burnett, M. S., Gaydos, C. A., Madico, G. E. et al. Atherosclerosis in ApoE knockout mice infected with multiple pathogens. *J. Infect. Dis.*, 183:226–31, 2001.
- Drazen, MD., J. M. et al. COX-2 inhibitors — A lesson in unexpected problems. *N. Engl. J. Med.*, 352:1131–1132, Number 11, March 17, 2005.
- Furberg, C. D., Psaty, B. M., FitzGerald, G. A. et al. Parecoxib, valdecoxib, and cardiovascular risk. *Circulation*, 111:249, 2005.
- Hsieh, E., Zhou, Y. F., Paigen, B. et al. Cytomegalovirus infection increases development of atherosclerosis in apolipoprotein-E knockout mice. *Atherosclerosis*, 156:23–8, 2001.
- Luis, A. G. R., Varas-Lorenzo, C., Maguire, A. et al. Nonsteroidal antiinflammatory drugs and the risk of myocardial infarction in the general population. *Circulation*, 109:3000–3006, 2004.
- Mukherjee, D., Nissen, S. E., and Topol, E. J. Risk of cardiovascular events associated with selective Cox-2 inhibitors. *JAMA*, 286:954–9, 2001.
- Paul, A., Calleja, L., Camps, J. et al. The continuous administration of aspirin attenuates atherosclerosis in apolipoprotein E-deficient mice. *Life Sci.*, 68:457–65, 2000.
- Pratico, D., Tillmann, C., Zhang, Z. B. et al. Acceleration of atherogenesis by COX-I dependent prostanoid formation in low-density lipoprotein receptor knockout mice. *Proc. Natl. Acad. Sci., U.S.A.*, 98:3358–63, 2001.
- Ray, W. A., Stein, C. M., and Daugherty, J. R. Cox-2 selective nonsteroidal anti-inflammatory drugs and risk of serious coronary heart disease. *Lancet*, 360:1071–3, 2002.
- Rott, D., Jianhui, Z., Burnett, S. et al. Effects off MF-tricyclic, a selective cyclooxygenase-2 inhibitor on atherosclerosis progression and susceptibility to cytomegalovirus replication in apolipoprotein-E knockout mice. *J. Am. Coll. Cardiol.*, 41:1812–9, 2003.
- Solomon, MD, S. D., McMurray, MD, J. J. V., Pfeffer, M. A. et al. Cardiovascular risk associated with celecoxib in a clinical trial for colorectal adenoma prevention. *N. Engl. J. Med.*, 352:1071–1080, Number 11, March 17, 2005.
- Topol, E. J. et al. Arthritis medicines and cardiovascular events — “House of Coxibs”. *JAMA*, 293:366–368, 2005.

Obesity and Heart Disease

- I. Incidence and Definitions
- II. Effects on the Cardiovascular System
- III. Management
- IV. Clinical Studies of Diets

GLOSSARY

atherosclerosis same as atheroma, raised plaques filled with cholesterol, calcium, and other substances on the inner wall of arteries that obstruct the lumen and the flow of blood; the plaque of atheroma hardens the artery, hence the term atherosclerosis (sclerosis = hardening).

dyslipidemia the same as hyperlipidemia, elevated blood cholesterol, LDL cholesterol, triglycerides, or low HDL cholesterol.

heart failure failure of the heart to pump sufficient blood from the chambers into the aorta; inadequate supply of blood reaches organs and tissues.

myocardial infarction death of an area of heart muscle due to blockage of a coronary artery by blood clot and atheroma; medical term for heart attack or coronary thrombosis.

I. INCIDENCE AND DEFINITIONS

You are considered obese if you are more than 25% above the average weight and have a high percentage of body fat. You are moderately obese if you are 25–50% above the average weight and have marked increase in body fat. A body weight exceeding the ideal weight by 75% is considered severe obesity. Measurement of body mass index (BMI), determined from your weight in kilograms divided by the square of your height in meters, is a useful measure of relative obesity:

- Normal range for BMI = 18.5 to 24.9 kg/m²
- Overweight range = 25.0 to 29.9
- Obesity = >30.0 kg/m²

Statistics from the Centers for Disease Control and Prevention indicate that more than 66% of American

adults are overweight and have a BMI greater than 25. More than 30% are frankly obese, having a BMI greater than 30; approximately 9% are diabetic, many are prediabetics, and more than 25% have metabolic syndrome.

A. Metabolic syndrome

Individuals with this syndrome possess more than 3 of the following:

- Increased abdominal girth with a waist measurement greater than 46 inches in men, 40 inches in women (visceral obesity) or BMI greater than 30kg/m²
- Dyslipidemia indicated by low serum levels of high-density lipoprotein (HDL) cholesterol and elevated triglycerides
- Hypertension
- Glucose intolerance that contributes to insulin resistance and an increased risk of diabetes and cardiovascular disease (see the chapter Diabetes and Cardiovascular Disease)

B. Metropolitan Height and Weight Tables

The Metropolitan height and weight tables are given in Tables 1 and 2. These tables are still relevant. If you are slightly overweight, you would be happy to learn that the earlier Metropolitan Life tables of ideal or average weights were derived from insurance applicants age 20–30 and do not represent the average weights of individuals age 40–60. If your weight is 10% more than that indicated in Tables 1 or 2, you can consider yourself slightly overweight, but there appears to be no health hazard unless you have other risk factors. The average weight of North Americans age 30–50 is about 10–15% above those indicated in Tables 1 and 2. Many North Americans age 35–70 are overweight, even by the conservative definition given above. If you are in this group and have other risk factors, you need to reduce your weight.

TABLE 1
1983 Metropolitan Life Height and Weight Tables for Men and Women

According to frame, ages 25–59: Men			
Height (in shoes) Feet inches	Weight in pounds (in indoor clothing)*		
	Small frame	Medium frame	Large frame
5 2	128–134	131–141	138–150
5 3	130–136	133–143	140–153
5 4	132–138	135–145	142–156
5 5	134–140	137–148	144–160
5 6	136–142	139–151	146–164
5 7	138–145	142–154	149–168
5 8	140–148	145–157	152–172
5 9	142–151	148–160	155–176
5 10	144–154	151–163	158–180
5 11	146–157	154–166	161–184
6 0	149–160	157–170	164–188
6 1	152–164	160–174	168–192
6 2	155–168	164–178	172–197
6 3	158–172	167–182	176–202
6 4	162–176	171–187	181–207

* Indoor clothing weighing 5 pounds for men and 3 pounds for women.

TABLE 2
1983 Metropolitan Life Height and Weight Tables for Men and Women

According to frame, ages 25–59: Women			
Height (in shoes) Feet inches	Weight in pounds (in indoor clothing)*		
	Small frame	Medium frame	Large frame
4 10	102–111	109–121	118–131
4 11	103–113	111–123	120–134
5 0	104–115	113–126	122–137
5 1	106–118	115–129	125–140
5 2	108–121	118–132	128–143
5 3	111–124	121–135	131–147
5 4	114–127	124–138	134–151
5 5	117–130	127–141	137–155
5 6	120–133	130–144	140–159
5 7	123–136	133–147	143–163
5 8	126–139	136–150	146–167
5 9	129–142	139–153	149–170
5 10	132–145	142–156	152–173
5 11	135–148	145–159	155–176
6 0	138–151	148–162	158–179

*Shoes with 1-inch heels.

Source of basic data: Build Study, 7979, Society of Actuaries and Association of Life Insurance Medical Directors of America, 1980.

Copyright 1983 Metropolitan Life Insurance Company.

II. EFFECTS ON THE CARDIOVASCULAR SYSTEM

If you are slightly overweight, this alone does not significantly increase your risk of having a heart attack, hypertension, or diabetes provided that you do not already have the risk factors — a family history of heart attacks occurring at an early age (before age 55), hypertension, high blood cholesterol, diabetes, smoking, and a stressful lifestyle. Obesity is different from being mildly overweight.

A. Coronary Heart Disease

The Framingham Study showed that in the 5000 people studied, being overweight appeared to increase the risk of sudden death and angina, but it did not increase the frequency of heart attacks. When adjustments were made for the prevalence of hypertension and hypercholesterolemia, then being overweight or obesity appeared to play a much less significant role.

If a patient with coronary heart disease manifested by recurrent chest pain on exertion (angina) or a myocardial infarction is overweight, chest pains are likely to be more frequent, as the heart has to work harder. Therefore, weight reduction helps in relieving pain in patients with angina pectoris, and less medication is then required.

B. Heart Failure

In patients with heart failure, weight reduction is necessary because increased weight means more work for the heart. In heart failure patients the heart muscle is weak and the muscle is unable to pump sufficient blood from the heart into the circulation; blood remains in the lungs causing fluid to accumulate causing shortness of breath and edema of the legs occur (see the chapters Heart Failure and Heart Attacks).

Kenchiah et al. investigated the relation between the BMI and incidence of heart failure among 5881 individuals in the Framingham heart study. In this large, community-based sample increased BMI was associated with an increased risk of heart failure. As compared with individuals with normal BMI, obese subjects had a doubling of the risk of heart failure.

C. Hypertension

Obesity is not a major cause of hypertension, but some obese patients do have increased blood pressure. A larger sized cuff is required for measuring blood pressure if the

individual's arm is large. If you are obese and lose weight, the blood pressure always falls. A significant number of obese patients have diabetes and elevated blood cholesterol, and if hypertension or cigarette smoking is added, the risk is considerably increased.

III. MANAGEMENT

A. Weight Reduction Diet

Weight loss depends on calories you do not eat and calories you burn up during exercise. A low-calorie diet must be combined with exercise that increases calorie expenditure; otherwise you will not be able to prevent weight gain, which often occurs three to six months after stopping a low-calorie diet. It is best to lose slowly and plan your strategy over a one-year period. Therefore, try to lose two to four pounds per month, that is, 24–48 pounds over one year.

The body of an obese individual is programmed to form fat and store it. In addition, cells slow down and you burn fewer calories than normal. Your metabolic rate is slower than normal. When you go on a crash diet, your metabolic thermostat is turned down to get by on less food. Start your exercise program first, and after a month of walking one to two miles daily and climbing two to three flights of stairs four times daily, increase the exercise and then start your diet. Remember that a brisk two-mile walk in 30 minutes burns about 200 calories. All diets that are proven to cause sustained weight loss over a period of years depend on a reduced intake of calories combined with an exercise program that burns up calories.

Cells and muscles need energy to carry out their work. Energy is measured in calories. The body cells are like light bulbs. A bulb lights up when it receives enough electrical energy. The cells derive energy from chemical reactions involving glucose, oxygen, hydrogen, and high-energy phosphate bonds. The body needs glucose because it is one of the chief sources of energy — calories.

The following example should help you understand weight loss and calories. Young diabetics lose a considerable amount of weight. Why? Insulin is required to transport glucose from the blood across the cell membrane to reach inside the cell to interact with other chemicals and thus produce energy. When insulin is absent, glucose cannot get into the cells. Therefore, glucose reaches high levels in the blood and is passed out in the urine. The cells require energy to function. When glucose is not present, the cells use fat as a source of energy. Thus, fat throughout the body is mobilized and broken down, resulting in

marked a weight loss of about 20–30 pounds in 2–3 months.

1. Carbohydrates

All weight reduction diets entail a major reduction in carbohydrates and saturated fats. Simple carbohydrate foods (sugar and starchy foods) break down in the body to form glucose (sugar). Most calories are derived from carbohydrates: flour products, potatoes, ground vegetables, rice, custard, and ice cream. Therefore, you need to make a list of all such foods and reduce them by 50–75% (one-half to three-quarters) of your usual intake. We have not printed such a list because they are readily available in most diet books.

2. Saturated Fats

A decrease in saturated fat as advised in the Cholesterol chapter is advisable. Total fat intake should be reduced from the average 40% of total caloric intake to 30%. One gram of fat is equal to 9 calories, thus reducing fat intake by 120 calories derived from fat is not a difficult undertaking. A filet mignon is not fattening. Thus you can eat filet mignon and chicken three times a week and still lose weight.

A smaller amount of calories are derived from lean meats. To lose weight, therefore, eat only vegetables and lean meats such as chicken and fish with fruit for dessert. An abundance of fresh vegetables, legumes, and nuts that include almonds and walnuts and a multivitamin supplement are required.

Weight loss will be achieved if you reduce your calorie intake to 1000 calories daily and burn up some calories by exercise. It is possible to eat attractive, appetizing meals and lose weight. Consider the following points in preparing your meals:

1. A high-protein, low-fat meal as detailed under the Heart Attack Prevention Diet is advisable.
2. Reduce intake of high-calorie foods such as carbohydrate consisting of refined sugars and refined starches. Remember that alcohol, mixes, beer, and soft drinks contain an abundance of calories.
3. Carbohydrate foods that have calories and can still be taken liberally include those containing high fiber. Foods with high fiber content allow you to eat a large meal; therefore, you feel satisfied. Most of the material stays longer in the stomach but is not digested and thus not absorbed into the blood. Your meal may have more calories, but you absorb only about half the amount of

calories. We agree that high-fiber diets have a definite role in weight reduction plans. High-fiber foods include wheat bran, green peas, chick peas, split peas, beans, corn and all vegetables and fruits such as apples, cherries, pears, plums, nectarines, because the skin containing high amounts of fiber is eaten.

A word of caution: Every intervention, be it type of diet or treatment, must be done in moderation. Note the high vitamin K content of certain high-fiber foods often recommended such as broccoli, turnip greens, spinach, and alfalfa. A high vitamin K intake may increase clotting factors in the blood. In addition, the occasional individual following a high-fiber diet may have an increase in stools from once to three times daily, but this often normalizes. Very rarely anemia and bone loss (osteomalacia or osteoporosis) as well as a decreased absorption of minerals such as calcium, zinc, or magnesium, may occur with a prolonged high-fiber reduction diet.

For those of you who have difficulty counting calories, simply try the following:

1. *Reduce* your usual intake of the following foods by one-half (50%) to three-quarters (75%). For example, four slices of bread daily becomes a maximum of two, or preferably one slice daily. All white flour products include bread, pasta, spaghetti, macaroni, and roti. Do not eat cakes, cookies, pastries, rice, or fried potatoes. One medium baked potato with skin can be eaten twice weekly. Avoid fast foods and canned foods because of their high calorie and salt content (see Table 3).
2. *Increase* your intake of all vegetables, including avocado, which is high in potassium and polyunsaturated fat. Avocado is not fattening as some would have us believe. Eat more of all fruits. Food with high fiber content except broccoli, turnip greens, and alfalfa, which are rich in vitamin K, should be increased. Small helpings of spinach or cabbage have less vitamin K and can be used. Fish, chicken, veal, turkey, and fatty fish contain good fats and should be eaten more frequently. In addition, if your blood cholesterol is greater than 240 mg (6 mmol/L), use only lean cuts of beef or steak twice weekly and only two eggs weekly.

This combination of foods will afford pleasant tasting meals that you can tolerate for a long period of time without depletion of protein, vitamins, or minerals. You will lose weight if you combine this diet with one hour of exercise at least five days weekly.

Obesity has been known to be a difficult problem to control. Motivation, willpower, and sacrifice are required. You may have greater success if you join a weight loss

program or consult with a nutritionist regularly. Though a behavior modification program may help some, to be really successful you need to find a weight loss program that will fit your particular lifestyle and weight loss goals.

You should not use diet plans that recommend low carbohydrates and advise a moderate-to-high fat intake. Some diet recipes reduce carbohydrates, but increase eggs, cheese, and meat products. Therefore, an increase in blood cholesterol may occur. Also, these very restrictive diets are difficult to follow for more than 9 months.

Studies have shown that liquid protein diets have certainly caused deaths and must not be used. Fifty deaths were reported in individuals who were using liquid protein diets. Seventeen of these individuals were known to be healthy, but developed abnormal heart rhythms while on the liquid protein diet. No deaths occurred in a well-supervised study, however, in which about 4000 individuals were given an adequate amount (70 g) of first-class protein daily, along with a very low calorie diet.

IV. CLINICAL STUDIES OF DIETS

A. The Atkins-Type Diet

An Atkins-type diet that prescribes a low-carbohydrate, high-protein, high-fat intake has been popular in the United States during the past decade. Despite the knowledge that high fat intake increases plasma LDL cholesterol levels and that this carries a high risk for the development of plaques of atheroma in vital arteries, this diet has been allowed to be promoted for more than 20 years. In addition, the efficacy of this type of diet had not been tested, in randomized controlled trials until recently and the trial was short-term not more than 12 months.

I. Foster et al.

This group conducted a randomized clinical trial comparing an Atkins-type diet versus what they deemed a conventional weight reduction diet: “a low calorie, high carbohydrate, low fat diet.” Unfortunately, the authors of the study state that “the *conventional dietary approach* to weight management recommended by leading research and medical societies is a high-carbohydrate, low-fat, energy deficit diet.” Leading researchers and medical societies have not advocated a high-carbohydrate intake as being part of a conventional weight-reduction program. Thus, the authors’ comparative diet flaws the study. Nonetheless, the small study provides some messages.

Methods: A one-year controlled trial involving only 63 obese men and women randomly assigned to either a low-carbohydrate, high-protein, high-fat diet (Atkins-type)

or a low-calorie, high-carbohydrate, low-fat diet (referred to by the investigators as a conventional diet). Characteristics of the individuals were age 44 ± 9 , BMI 34 ± 3 , and weight 98 ± 19 kg. These individuals could be classified as overweight individuals and not necessarily obese. There were no diabetics and no patients with metabolic syndrome, and there was no evidence of significant dyslipidemia. The HDL cholesterol was approximately 47 mg/dl in both groups.

Results: At six months individuals on the low-carbohydrate diet not surprisingly lost more weight than subjects on the high-carbohydrate, low-fat diet (-7.0 ± 6.5 vs. $-2.5 \pm 6.3\%$ of the body weight; $P = 0.02$), *but there was no significant difference at 12 months.*

Conclusions: Adherence was poor and attrition was high in both groups. Only 42 and 37 individuals remained in the study at 6 and 12 months, respectively. Longer and larger studies are required to determine the long-term safety and beneficial effects of low-carbohydrate, high-protein, high-fat diets.

Perspective: Less than 60% of subjects adhered to the diets at 12 months indicating that any approach to caloric restriction that is not compatible with normal daily lifestyle patterns is unlikely to produce beneficial weight reduction sustained over a long-term period of several years. Caution is necessary because the dangerous LDL cholesterol increased in the low-carbohydrate, high-fat group and decreased slightly in the low-fat group. The HDL cholesterol showed a mild increase in the subjects following the low-carbohydrate, high-fat diet, but this may reflect a change in HDL subfractions which occurs with increased intake of saturated fat. This change has not been shown to be beneficial, thus, caution is required in the interpretation of this data. A diet high in saturated fat is known to be atherogenic and harmful to health and cannot be recommended under any circumstances. In addition the Atkins-type diet is unproven over the long term. This type of diet has not been adequately tested in patients with cardiovascular disease, diabetics, patients with dyslipidemia, or in subjects with metabolic syndrome. Subjects in the study by Foster et al. had an average weight of 220 lbs and BMI of approximately 34, features of mild obesity. The long-term effects in patients with a moderate degree of obesity (BMI 35–40), diabetes, or metabolic syndrome have not been tested. Fortunately individuals who weigh less than 400 pounds with a BMI >50 are a small percentage of the population and have some form of as yet undefined underlying pathologic defect probably related to hypothalamic-endocrine adipose tissue dysfunction.

Adverse effects of an Atkins-type diet include atherogenicity, which potentially leads to atherosclerosis and an

increased incidence of coronary events. This is of concern for a diet that has not been tested in patients at risk for cardiovascular events. Calciuria, which causes renal stones and decreased bone mass, is another adverse effect. A high-protein diet must be avoided in patients with renal and hepatic disease.

B. A Low-Carbohydrate Diet Compared with a Low-Fat Diet

I. Samaha et al.

Methods: The investigators randomly assigned 132 severely obese individuals (including 77 blacks and 23 women) with a mean BMI of 43 and a high prevalence of diabetes (39%) or metabolic syndrome (43%) to a carbohydrate-restricted (low carbohydrate) diet or a calorie- and fat-restricted (low fat) diet. It is important to recognize that the low-carbohydrate diet used did not have the additional high-protein, high-fat component of the Atkins-type diet. The individuals assigned to the low-carbohydrate diet were instructed to restrict carbohydrate intake to 30 g per day or less; no instruction on restricting total fat intake was provided. The low-fat diet group was advised to create a deficit of 500 calories per day with 30% or less of total calories derived from fat.

Results: A 6-month program was completed by 79 individuals. Individuals on the low-carbohydrate diet lost more weight than those on the low-fat diet (-5.8 ± 8.6 kg, vs. -1.9 ± 4.2 kg; $P = 0.002$) and had greater decrease in triglyceride levels (-20 vs. -4%).

Conclusions: This was a study of severely obese individuals with diabetes or metabolic syndrome, and these individuals lost more weight at six months on a carbohydrate-restricted diet than on a calorie- and fat-restricted diet. The authors warn that this finding should be interpreted with caution given the small magnitude (9–18 pounds) of overall loss and group differences in these markedly obese subjects and the short duration of the study. The plasma cholesterol, LDL cholesterol, and HDL cholesterol did not change significantly during the 6-month study within or between groups.

In both the Foster and the Samaha studies, significantly greater weight reduction with the low-carbohydrate diet

than with the reduced fat diet during the first six months (average reduction of 6–7 kg vs. 2–3 kg) was observed. The magnitude of the weight loss difference (4 kg in both studies) was, however, relatively small and adherence in the two diet groups was low. Further studies evaluating long-term outcomes are needed before a carbohydrate-restricted, relatively normal fat diet can be endorsed for long-term use. A low-carbohydrate, high-fat, high-protein diet affords no advantages and may have deleterious consequences in the long-term. It is not recommended.

C. Recommendations

The combination of a low saturated fat, reduced carbohydrate intake, increased vegetables and fruits with a balanced food content and liberal exercise is recommended until further long-term studies are available.

BIBLIOGRAPHY

- Bonow, R. O., and Eckel, R. Diet, obesity and cardiovascular risk. *N. Engl. J. Med.*, 348:2057–58, 2003.
- Dansinger, M. L., Gleason, J. A., Griffith, J. L. et al. Comparison of the Atkins, Ornish, Weight Watchers, and Zone Diets for weight loss and heart disease risk reduction: A randomized trial. *JAMA*, 293:43–53, 2005.
- Eckel, R. H., York, D. A., Rössner, S. et al. Prevention conference VII: Obesity, a worldwide epidemic related to heart disease and stroke: Executive summary. *Circulation*, 110:2968–2975, 2004.
- Foster, G. D., Wyatt, H. R., Hill, J. O. et al. A randomized trial of a low carbohydrate diet for obesity. *N. Engl. J. Med.*, 348:2082–90, 2003.
- Kenchiah, S., Evans, J. C., Levy, D. et al. Obesity and the risk of heart failure. *N. Engl. J. Med.*, 347:305, 13, 2002.
- Klein, S., Burke, L. E., Bray, G. A. et al. Clinical implications of obesity with specific focus on cardiovascular disease: A statement for professionals from the American Heart Association Council on Nutrition, Physical Activity, and Metabolism: Endorsed by the American College of Cardiology Foundation. *Circulation*, 110:2952–296, 2004.
- Mullis, R. M., Blair, S. N., Aronne, L. J. et al. Prevention conference VII: Obesity, a worldwide epidemic related to heart disease and stroke: Group IV: Prevention/Treatment. *Circulation*, 110:e484–e488, 2004.
- Samaha, F. F., Iqbal, N., Seshadri, P. et al. A low carbohydrate as compared with a low fat diet in severe obesity. *N. Engl. J. Med.*, 348:2074–81, 2003.

Pacemakers

- I. Historical
- II. Complete Heart Block
- III. Second Degree AV Block
- IV. Sinus Node Dysfunction
- V. Permanent Pacemakers
- VI. What a Pacemaker will not do
- VII. Activities

GLOSSARY

AOO a pacemaker that stimulates the atrium as a fixed rate, independent of atrial activity.

capture effective depolarization of the heart by the artificial pacemaker.

demand or inhibited pacemaker any pacemaker that inhibits its output upon sensing a natural or paced event and fires at the preset rate when the sinus rate falls below the pacemaker's programmed escape rate.

transvenous anything that passes through a vein (catheter or pacemaker lead)

WHEN THE HEART TEMPORARILY STOPS BEATING for 10–30 seconds, or the heart beat *suddenly* becomes remarkably slow (< 30 beats per minute) transient loss of consciousness occurs. This may be accompanied by convulsive seizures that resemble an epileptic attack, or the patient may fall without sufficient warning and injuries or death may occur. The invention of the cardiac pacemaker is one of the greatest cardiologic developments of modern medicine. Countless lives have been saved and accidents prevented by this innovative technologic solution.

I. HISTORICAL

In 1719 Gerbezius described a patient with a very slow pulse. The patient often had dizzy spells and from time to

time was subjected to slight epileptic attacks. He did not connect the slow pulse as the reason for the seizures. In 1761 Morgani reported two cases with recurrent fainting spells associated with slow pulse rate, but listed the disturbance as neurological, perhaps, because it was associated with convulsive seizures. In 1826 Robert Adams was the first to realize that the loss of consciousness (apoplectic attack or seizures) was related to a very slow pulse rate and that the disorder had a cardiac origin. Later an autopsy revealed fatty degeneration of the myocardium and Adams assigned a cardiac cause for the seizure-like disorder.

In 1846 Stokes was a firm believer in the use of the stethoscope, which had been developed by Laennec in 1820. Stokes first observed two cases. He further analyzed and correlated seven cases from other physicians and was the first to describe the cardiac condition accurately in detailed writings and publications. He stated that the apoplectic seizures were caused by episodic deficits in the arterial blood supply to the brain, and through his publications and textbooks the syndrome became known to physicians. The syndrome was first labeled Stokes-Adams syndrome or Stokes-Adams attacks.

In 1895 His discovered the underlying cardiac condition which was delineated when he experimentally produced heart block. He suggested that a lesion of the atrioventricular (AV) bundle was responsible for blocking the conduction of electrical impulses from the atrium to the ventricles (see Fig. 1). His further documented the condition in a patient with heart block associated with syncope and a recording was made with Sir James Mackenzie's polygraph.

In 1913, Sir Thomas Lewis recorded the electrocardiogram of a patient with complete heart block.

The world of cardiac pacing had to wait until Seymour Furman, in 1958, illustrated that transvenous endocardial cardiac pacing with a pacemaker electrode placed in the right ventricle corrected the electrical problem and was a safe technique. The first small clinical trials described the successful use of transvenous temporary cardiac pacing. This technique could not have evolved without cardiac catheterization skills and techniques that began in Germany

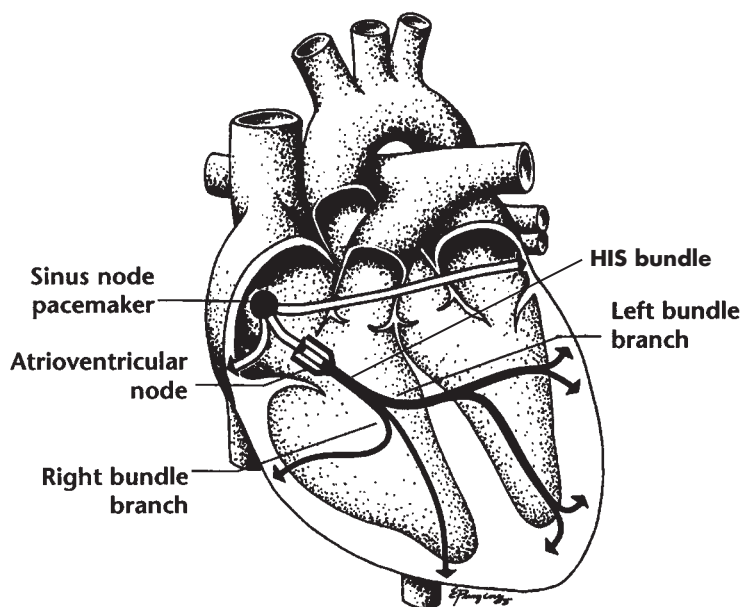

FIGURE 1 Electrical system of the heart. (From Khan, M. Gabriel, and Marriott, H.J.L. (1996). *Heart Trouble Encyclopedia*, Toronto: Stoddart Books, p. 230.)

in the late twenties by Forssmann, who advanced a ureteral catheter from a vein in his arm into the right atrium. Then in the late forties the established role of catheterization was taken further by Cournand and others.

The first electrode used on preliminary dog studies was a diagnostic Cournand cardiac catheter with a steel wire as a conductor soldered distally to a bit of tinfoil wrapped around the tip of the catheter. A Swedish physician, Ake Senning, performed a permanent implant that year using a Siemens pacemaker.

II. COMPLETE HEART BLOCK

A. Pathophysiology

Normally an electrical current originates in the sinus node (the natural pacemaker) and is conducted through the AV node (Fig. 1). It then traverses the right and left bundle branches to reach the ventricular muscle and endocardium. The electrical current stimulates cardiac contraction that causes ejection of blood from the left ventricle into the aorta which results in an adequate supply of blood, oxygen, and other nutrients to the brain and vital organs. The electrical current may be halted by diseases that destroy the specialized conducting tissue in the AV node or lower in the bundle of His; the current fails to reach the ventricle and no cardiac contraction occurs (asystole). The brain

is deprived of blood and the individual loses consciousness. The block in the electrical conduction may be temporary and last several seconds to a minute. With return of electrical conduction, blood supply to the brain is restored and the patient recovers. If blood fails to reach the brain and head, the facial skin becomes blanched and when the heart begins to contract again blood is pushed quickly and rapidly into the facial arteries causing intense flushing of the face. Loss of consciousness accompanied by facial pallor and during recovery followed flushed facies is a characteristic of complete heart block (Stokes-Adams attacks).

If blood supply to the brain is cut off for more prolonged periods convulsive seizures may occur and with more prolonged asystole death may result. Transient loss of consciousness occurring in a patient who is lying down suggests Stokes-Adams syndrome or epilepsy. Epilepsy, however, is often associated with premonitory symptoms, urinary incontinence, and convulsions, but the pulse rate is not slowed. With complete heart block the heart rate is usually less than 30 beats per minute followed by several seconds of no heartbeats and possible loss of consciousness. This condition is called complete heart block because there is a block of the conduction of electrical impulses from the atrium through the main electrical tunnel (AV node) that transmits the impulses to the ventricle (see Fig. 1). The atrium normally contracts at 60–80 beats per minute and in heart block continues to beat at 72 beats

per minute, but the ventricles fail to receive the message to do the same. Pacemaker cells in the ventricle may create an electrical impulse but beat at a rate less than 36 beats per minute. Occasionally, in this condition, the ventricles fail to contract, as there is no electrical stimulus (asystole) or the ventricle quivers (ventricular fibrillation) and loss of consciousness occurs. The most dramatic manifestation of asystole is severe cerebral ischemia, varying from mild dizziness to classical Stokes-Adams seizures. In such patients a pacemaker site in the ventricle may suddenly restart the heart and the patient recovers in a few seconds.

B. Causes of Complete Heart Block — Third Degree AV block

I. Coronary Artery Disease: Myocardial Infarction

In 2 of every 100 patients with a heart attack, the electrical pathway connecting the atrium and the ventricle (AV node and bundle of His) become damaged and the heart rate becomes very slow (see Fig. 1). The heart rate may fall to less than 30 beats per minute and asystole may supervene. If the condition does not respond to drugs such as atropine, a temporary pacemaker, which is required for only 2–5 days, is inserted through a vein in the neck. If further damage occurs to the conducting tissue complete heart block may occur.

2. Idiopathic Degenerative Disease

Lenegre's disease and Lev's disease are two lesions that involve the electrical conduction bundles and produce complete heart block in the absence of associated damage due to coronary artery disease (myocardial infarction) and myocardial diseases. Lev's disease is caused by an invasion of the conduction bundles by fibrosis or calcification spreading from any of the fibrous structures adjacent to the conducting system. Severe calcification of the aortic valve may cause complete AV block. Fibrosis or calcification of the central fibrous body of the mitral valve ring is a cause of complete heart block in the elderly. Lenegre's disease is a sclerodegenerative process involving only the electrical conducting system. In this rare degenerative disease of the conduction system the electrical wires of the heart are bad, but the heart muscle, coronary arteries, and valves are relatively normal. In patients with degenerative disease of the conduction system and with congenital heart block, the remainder of the heart is completely normal and the insertion of a permanent pacemaker allows for normal activity and life span.

These degenerative diseases may cause right bundle branch block and left anterior hemiblock in persons over the age of 50 with slow progression to complete heart block a decade or more later (see Chapter Bundle Branch Block).

3. Infections

Chagas disease is an important cause of conduction blocks and is prevalent in South America (see chapter entitled Chagas Disease). Other infections that cause conduction blocks include Lyme disease, viral myocarditis, infective endocarditis, toxoplasmosis, tuberculosis, diphtheria, and syphilis.

4. Collagen Vascular Disease

Complete heart block may rarely occur as a complication of rheumatoid arthritis, scleroderma, dermatomyositis, ankylosing spondylitis, polyarteritis nodosa, lupus erythematosus, and Marfan syndrome.

5. Infiltrative Diseases

These disease include hemochromatosis, amyloidosis, sarcoidosis, and rarely lymphomas and other forms of cancer.

6. Neuromuscular Disease

Myotonic muscular dystrophy, peroneal muscular dystrophy (Charcot-Marie tooth disease), and other dystrophies are included in this classification.

7. Congenital

Cases of heart block may occur in childhood because of a congenital defect in the conduction system. The AV node may have been the vulnerable target of anti-Ro antibodies. The block may be associated with other complicated congenital malformations including corrected transposition and ventricular septal defect. Fortunately this condition is rare and occurs as an isolated finding.

8. Drug effects

Digoxin, amiodarone, and verapamil (a calcium antagonist) may rarely cause complete heart block.

9. Iatrogenic

Therapeutic AV node ablation, inadvertent damage during procedures, postoperative or traumatic causes, and occasionally therapeutic irradiation of the chest may cause complete heart block.

C. Diagnosis

Findings of heart block on the ECG are diagnostic (see the chapter Electrocardiography). Figure 2 shows complete absence of AV conduction manifested by P waves and QRS complexes that are entirely independent. There are more P waves than QRS complexes, and the ventricles beat regularly. This is indicated by regularly occurring QRS complexes. The ventricular rate (heartbeat) is less than 40 beats per minute, but with congenital heart block it may be as high as 50 beats per minute or more. Plenty of P waves are visible and the P to P intervals are equal and constant.

III. SECOND DEGREE AV BLOCK

Type II second degree AV block (Mobitz type II block) associated with a bundle branch block pattern is due to conduction defects usually below the bundle of His. Other dropped beats are caused by intermittent block in the

bundle branch. This type of block often progresses insidiously to complete heart block with Stokes-Adams attacks. This diagnosis is made from the ECG when at least two regular and consecutive atrial impulses are conducted with the same PR interval before the dropped beat and the P to P intervals are equal. Permanent pacing is usually required.

IV. SINUS NODE DYSFUNCTION

In this condition, because of coronary heart disease, degenerative disease, or unknown cause the normal sinus node pacemaker may have been destroyed because of lack of blood supply or replaced by fibrous tissue. The heartbeat then becomes erratic and the heart may beat very slowly (28–42 beats per minute) and at other times may beat very quickly (100–150 per minute). Thus the condition is sometimes called bradytachycardia or sick sinus syndrome.

With sick sinus syndrome the patient may complain of dizziness or transient loss of consciousness (syncope) that occurs without warning. This condition is common and is most often seen in individuals over age 65. It is important to document that these symptoms are due to a sick sinus, because they can also be caused by several other conditions including cerebral arterial disease which causes lack of blood circulation to the brain for which a

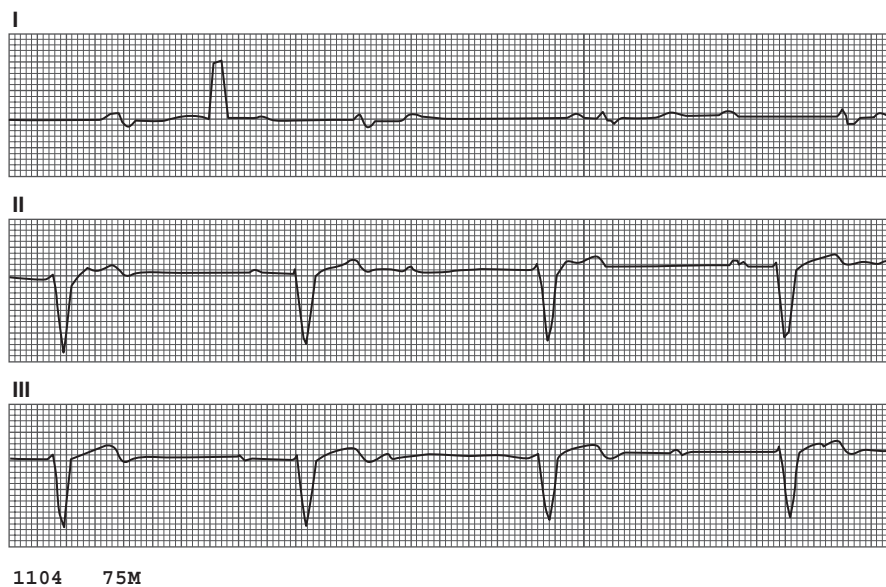

FIGURE 2 Complete atrioventricular block with idioventricular rhythm. The QRS complexes are abnormally wide and are different from those seen during sinus rhythm. The ventricular rate is 36 bpm. (From Chou, T.C. (1996). *Electrocardiography in Clinical Practice*, 4th ed., Philadelphia: W.B. Saunders.)

pacemaker will not help. If the diagnosis is established as sick sinus syndrome, a permanent pacemaker is inserted and the patient gets complete relief of symptoms.

V. PERMANENT PACEMAKERS

A. Types of Pacemakers

A cardiac pacemaker is an electronic device that senses cardiac electrical activity and delivers electrical stimuli to the heart when needed. If the natural pacemaker (AV sinus node) is no longer working well or the electric current is blocked by disease of the conducting bundles, a pacemaker can be implanted. A pacemaker lead (electrode) is inserted into the right ventricle and the pacemaker (pulse generator) is inserted just under the skin (see Fig. 3). The lead is then attached to the pacemaker. A small electrical current is passed through the lead at the rate set by the cardiologist. When the impulse reaches the heart muscle the muscle contracts in the same way it would as if the electrical impulse occurred naturally.

The pacemaker generator can be visualized as an eye that stands guard over ventricular and in some cases atrial activity. If the eye sees ventricular activity it inhibits its own output electrical pulse, but if it sees no activity it delivers an electrical stimulus to the ventricle to keep it beating at a programmed rate. (see Fig. 4).

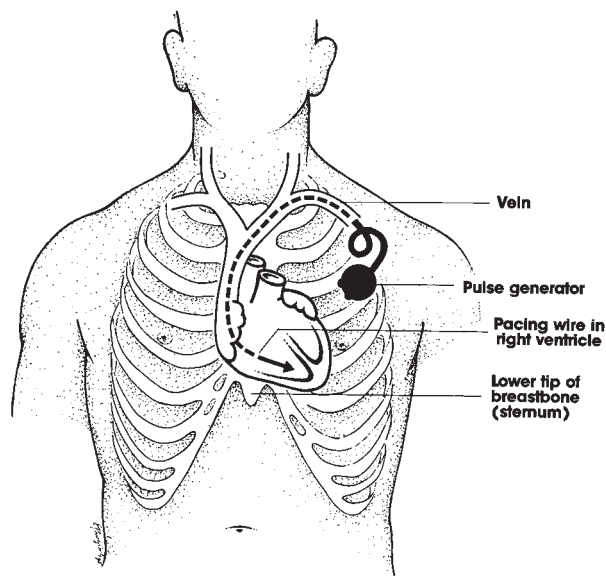

FIGURE 3 Artificial pacemaker. (From Khan, M.G., and Marriott, H.J.L. (1996). *Heart Trouble Encyclopedia*, Toronto: Stoddart Publishing, p. 224.)

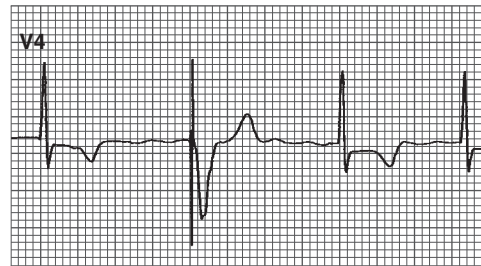
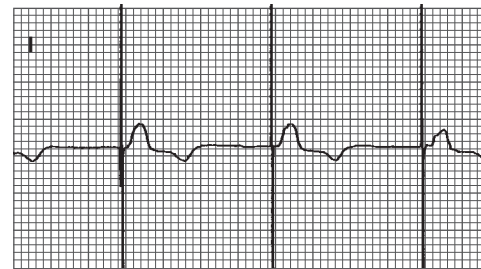

FIGURE 4 Electronic pacemaker, demand mode; ventricular capture rate = 75 bpm. The spontaneous beat in V_4 is followed by sensing and pacemaker capture at the appropriate interval, which is equal to that shown in lead I. The pacemaker output is inhibited appropriately in response to the intrinsic QRS complex (the first beat in lead V_4).

Permanent pacemakers can be classified on the basis of five characteristics:

1. The cardiac chamber paced by the device, ventricle (V), or atrium (A)
2. The chamber sensed by the device (V or A)
3. Device response to sensing
4. Device programmability
5. Additional functions.

A five-position North American Society of Pacing and Electrophysiology/British Pacing and Electrophysiology Group generic pacemaker code is used to describe pacemakers on the basis of the above features. VVI pacing has a ventricular lead placed in the ventricle which paces and senses only the ventricle. It looks for ventricular electrical activity and delivers its stimuli when necessary; so that it paces only the ventricle, senses only the ventricle, and responds to sensing by inhibition of its stimulus. Thus the output of the pacemaker is inhibited by the sensed normal ventricular signal as shown in Fig. 4. Generally the first three or four positions are used; for example, a VVIR pacemaker implies a pacemaker that paces and senses the ventricle, is inhibited by a sensed event, and has rate response function. Figure 5 shows AOO, VDD, and DDD pacing modes.

There are numerous pacemaker systems on the market. A cardiologist or cardiac surgeon will choose the one

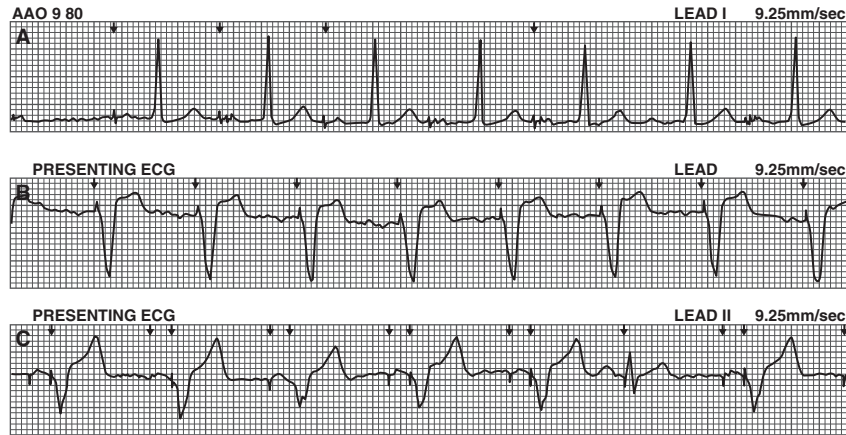

FIGURE 5 Different modes of pacemaker function are shown. (A) AAO, fixed rate atrial pacing. Note narrow, paced QRS complexes in response to paced atrial beats. (B) VDD, the pacemaker senses the atrium and the ventricle and paces the ventricle. Each spontaneous P wave is followed by a paced ventricular complex. (C) DDD, the pacemaker senses and paces in the atrium and the ventricle. The sixth complex of this strip represents a spontaneous P wave that conducts to the ventricle, resulting in a narrow QRS complex with the pacing spike occurring in the ventricular refractory period. Arrows indicate pacing stimulus artifacts. (From Saksena, S. (1996). *Nonpharmacologic therapy for cardiac arrhythmias: cardiac pacing, implantable cardioverter-defibrillators, catheter and surgical ablation.* (Khan, M. Gabriel, Ed.). Baltimore: Williams & Wilkins.)

appropriate pacemaker for each patient. Usually, the individual requiring a pacemaker is admitted to the hospital. The pacemaker is inserted by a cardiac surgeon and occasionally by a cardiologist during a simple operation. A pacemaker consists of a heart generator that weighs about 30 g and is implanted under the skin of the lower abdomen or near the collarbone. The tips (leads) of the pacing wire that emerge from the pacemaker generator are inserted into the vein and threaded through to reach a position inside the right ventricle (see Fig. 3). Another method that is occasionally used attaches the tips of the pacing wire to the outside surface of the right ventricle. This type of pacemaker is called a ventricular pacemaker.

Another type of pacemaker, dual-chamber, has certain advantages for some patients. It utilizes two pacing wires and one is positioned in the right ventricle and the other in the right atrium. This DVI (AV sequential) pacemaker paces both chambers but senses only the ventricles. It is inhibited upon sensing normal electrical ventricular activity (a QRS complex).

Prior to 1972, the power source for pacemakers was derived from batteries that were chiefly mercury-zinc. These were heavy and only lasted 2–4 years. Now, most modern pacemakers are programmable, that is, by placing a device on the skin over the generator radio signals are delivered to the pacer circuitry. This simple procedure is done in a clinic. The patients are usually followed for 6–12 weeks after the pacemaker is inserted, then twice annually. If signs of power-source depletion are observed, the patient is then seen monthly. Power-source depletion is easily detected as a decrease in rate when the system is monitored by passing a magnet over the generator. Batteries are

changed every 10 years depending on the make of the pacemaker. Changing the pacemaker batteries requires minor surgery. The flap of skin is lifted and the pacemaker generator is replaced. Pacemakers are often programmed so that they work only when the patient's heart beats below the set rate.

B. Electrical Safety

Current pacemakers are electrically shielded so that it is no longer necessary to avoid electrical equipment, as was the case with older pacemaker systems. However, some caution is required. Use only grounded (three-prong plug) electrical tools such as saws and drills.

- Use microwave ovens with caution. The newer models are well protected and little radiation occurs. If you use the microwave often and become dizzy, step away from the oven
- Use a rechargeable electric razor or hand razor rather than one that plugs into the wall.
- Check whether a person with a pacemaker can pass through the electronic device safely at airports.
- When using an electrical device for the first time, if you become dizzy turn the equipment off and refrain from using the device.

C. Complications

I. General Complications

General complications are uncommon but numerous and include vein damage causing extensive bleeding, embolus

or thrombosis, pneumothorax, thromboembolism, lead placement dislodgment or perforation of the right ventricle or coronary sinus, and infection or local hematoma of the generator.

Seek immediate attention for the following:

- Increased shortness of breath
- Marked tiredness and fatigue
- Swelling of the extremities, fingers, hands, and ankles
- Fever from 100–104 °F
- Drainage from of the incision or swelling and increased tenderness or redness of the incision
- Prolonged periods of dizziness or momentary dizziness when changing positions such as getting out of bed
- Fainting spells, syncope must be dealt with immediately
- Prolonged hiccoughing.

2. Pacemaker Syndrome

Some patients with or without normal ventricular function may experience symptoms with ventricular pacing. These symptoms include exercise intolerance, dyspnea, cough, chest discomfort, abdominal distention, nausea, fatigue and tiredness, dizziness, syncope or presyncope, and hypotension. This constellation of symptoms is referred to as “pacemaker syndrome” and is a result of loss of AV synchrony. The diagnosis of pacemaker syndrome should always be considered when persistent or new symptoms suggestive of low cardiac output or heart failure occur after satisfactory implantation of a permanent ventricular pacemaker. Symptoms may be directly induced or exacerbated by pacing.

A dual-chamber pacemaker is the treatment of choice in patients with pacemaker syndrome. Maintenance of AV synchrony is important in these patients as VA conduction causes hemodynamic derangements that raise atrial

pressures and decrease cardiac output with associated symptoms.

3. Pacemaker Malfunction

Malfunctions include:

- Sensing malfunction (see Fig. 6)
- Oversensing
- Pacing malfunction
- Lead fracture
- Pulse generator malfunction
- Pacemaker infection.

D. Temporary Pacing

It may be necessary to insert a temporary pacemaker in patients where a heart attack has disturbed the electrical conducting system of the heart and spontaneous recovery is expected within a few days. This procedure is a simple one. The temporary pacemaker consists of a pacing wire that is inserted through a vein in the neck, usually the subclavian vein. The skin over the vein is infiltrated with a local anesthetic so that the procedure is not painful. A pacing catheter is threaded through the vein to reach the inside of the right ventricle. The passage of the pacing catheter is usually done under fluoroscopic (x-ray) control because the wire is radio-opaque and can be seen on x-ray. Occasionally this procedure is done with the assistance of an ECG and the final position of the catheter is verified by x-ray. The external end of the wire catheter is connected to a battery-operated pulse generator (see Fig. 3). The pulse generator is set, for example, at 65 beats per minute and commences pacing if the heartbeat falls below this set rate. The pacemaker works (fires) only when it is required. Complications are very

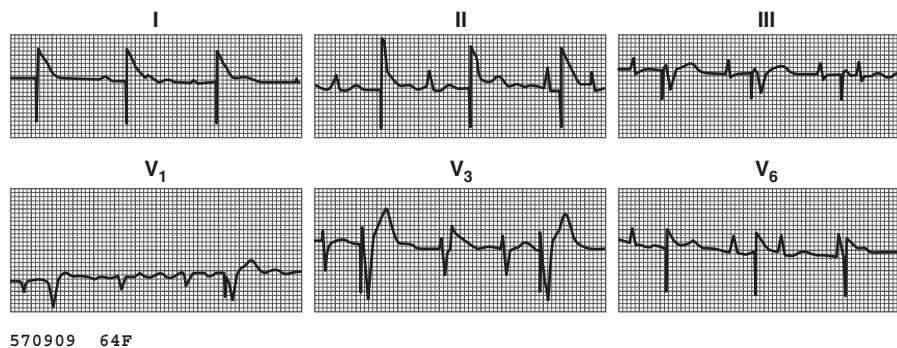

FIGURE 6 Ventricular demand pacemaker (VVI) with sensing malfunction. The pacemaker operates like a fixed-rate pacemaker. The spontaneous ventricular beats are not sensed. The spontaneous rhythm is atrial fibrillation. (From Chou, T.C. (1996). *Electrocardiography in Clinical Practice*, 4th ed., Philadelphia: W.B. Saunders.)

few for the insertion and maintenance of a temporary pacemaker.

VI. WHAT A PACEMAKER WILL NOT DO

A pacemaker does not cause the heart muscle to contract more forcefully; therefore, it does not help heart failure, except in some cases where a very slow heart rate was contributing to the heart failure. In a special group of patients with heart failure and intraventricular conduction delay pacing the heart may decrease the recurrence of heart failure (see the chapters Heart Failure and Bundle Branch Block).

A pacemaker does not increase the blood supply through the coronary arteries; therefore, it does not help chest pain or angina or prevent a heart attack. It does not replace the usual cardiac medications prescribed for various heart conditions. Prescribed medications must be continued for heart failure, angina, or other conditions that may exist. A pacemaker is a great device but it does only what it is designed to do. It stimulates the electrical system of the heart so that the heart beats at the correct time and at an appropriate rate. A pacemaker can prolong life provided the problem is a slow a heart rate or no heartbeat because of heart block.

VII. ACTIVITIES

Patients are allowed to exercise freely to the extent of major advances in electronics, and now virtually all pacemakers are powered by a variety of lithium batteries. The life of the lithium pacemaker varies from 7–10 years. Each patient is given a card that documents the type, model, serial number, date of installation, and approximate life of the pacemaker and should carry the card at all times and wear a pacemaker awareness bracelet.

Pacemaker patients are strongly advised to attend a pacemaker clinic for follow up in order to detect the rare occurrence of intolerance. Many are able to jog one to five miles daily and do similar exercises if angina or heart failure are not present. A patient with a pacemaker can lead a normal life.

BIBLIOGRAPHY

- Acierno, L. J. Electrophysiologic disturbances. In *The History of Cardiology*. Parthenon Publishing, New York, 1994.
- Cooper, J. Cardiac pacing. Heart talk/Tampa tracings, Florida, 1988.
- Saksena, S. Cardiac pacing. In *Heart Disease Diagnosis and Therapy*. M. Gabriel Khan, ed. Williams & Wilkins, Baltimore, MD, 1996.

Patent Foramen Ovale

- I. Developmental Features
- II. Clinical Features and Investigations
- III. Proof of PFO Involvement in Stroke
- IV. Perspective and Research Implications

GLOSSARY

cryptogenic of obscure or doubtful origin.

embolism, embolus a blood clot that forms in an artery, a vein, or the heart and breaks off and is carried by the circulating blood, finally lodging and blocking the artery that supplies an organ with blood; for example, pulmonary embolism is an embolus blocking an artery in the lung.

TIA transient ischemic attack; transient lack of blood supply (ischemia) to the brain causing symptoms of mild stroke that recover within 24 h.

DURING THE PAST 15 YEARS, BECAUSE OF echocardiographic visualization of the left atrium and the septum, it became apparent that a patent foramen ovale (PFO) is present in approximately 25% percent of a randomly selected population. Because the transesophageal echocardiogram (TEE) gives excellent clarity of this region of the heart, it is the preferred method of study for diagnosis. There has been increasing interest in PFO and its role in systemic embolization especially to the brain which causes stroke of undetermined etiology (cryptogenic stroke).

I. DEVELOPMENTAL FEATURES

During fetal development PFO allows the necessary shunting of oxygenated blood from the right atrium to the left atrium; thus, oxygenated blood flows into the systemic circulation to organs and tissues. This right-to-left shunting of blood is crucial for fetal development, but it is also vital that no shunt should occur after birth, because the right side of the heart is no longer filled with

oxygenated blood. A right-to-left shunt in individuals with congenital heart disease (CHD) causes cyanotic congenital heart disease which is life-threatening (see chapter entitled Congenital Heart Disease).

The foramen is formed by overlapping flaps of the septum primum and septum secundum (See Figure 1). These septa finally fuse to form the atrial septum in the newborn (see the figures in the chapter Embryology and the figures provided in the chapter Anatomy of the Heart and Circulation). The foramen usually closes at the time of birth because of the acute decrease in pulmonary vascular resistance and increased pressures on the left side of the heart. It normally fuses completely within 2 years. A PFO has been noted in up to 25% of structurally normal hearts

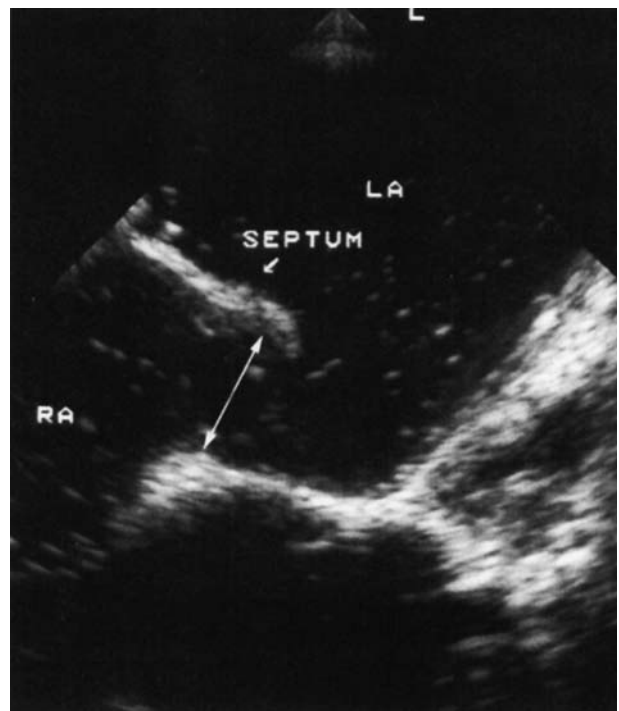

FIGURE 1 Longitudinal imaging transesophageal echocardiography in the mid-upper esophagus. A large patent foramen ovale (PFO) is evident. The arrow illustrates how to measure the PFO width. LA = left atrium; RA = right atrium. (From Kerut, E. K. et al. (2001). *J. Am. College Cardiol.*, 38(3), 614.)

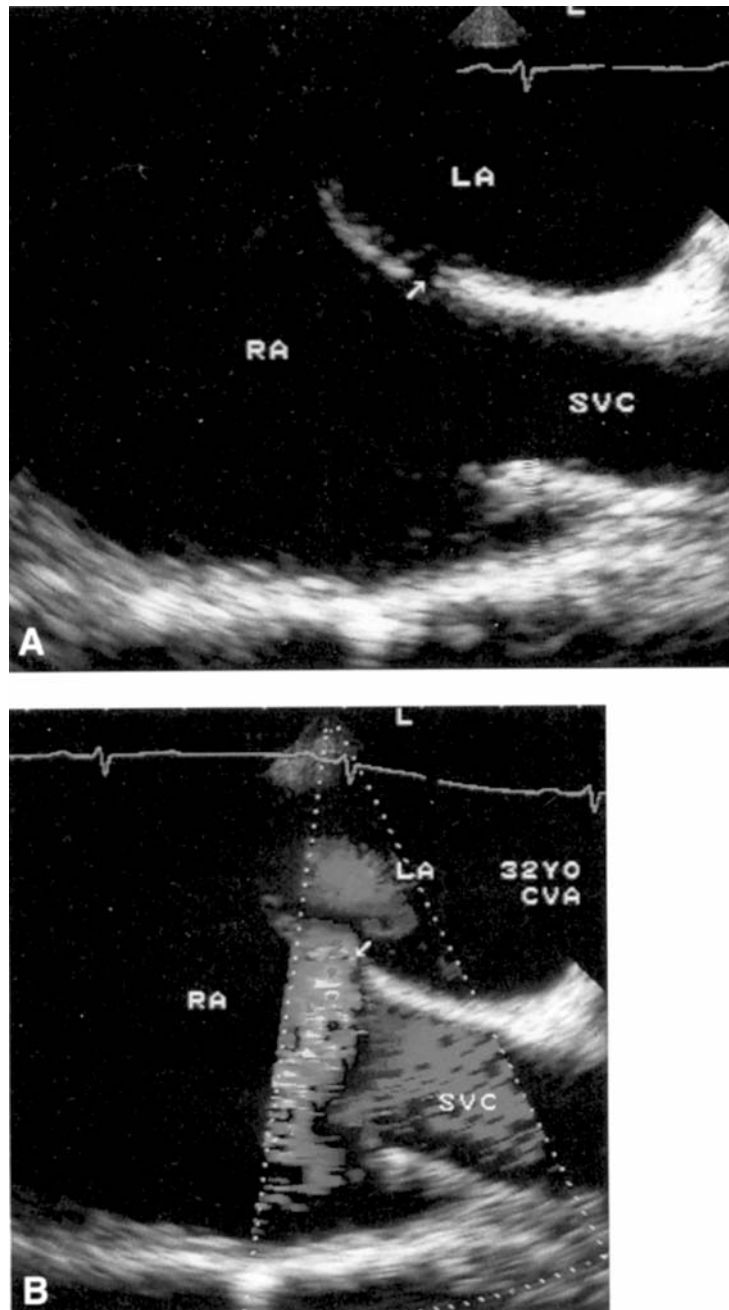

FIGURE 2 Longitudinal transesophageal echocardiography (TEE) imaging in the mid-upper esophagus. A 32-year-old male presented with an embolic stroke. He was found to have occult thrombi in both calf veins. Transthoracic echocardiography with peripheral saline contrast during normal respiration and Valsalva were negative for a right-to-left shunt. (A) TEE revealed a small restrictive secundum atrial septal defect (ASD) (arrow). Note how this appearance is different from that of a patent foramen ovale. (B) Color Doppler demonstrates a left-to-right shunt with a color mosaic pattern from the shunt in the right atrium (RA). The ASD was subsequently surgically repaired. LA = left atrium; SVC = superior vena cava. (From Kerut, E. K. et al. (2001). *J. Am. College Cardiol.*, 38(3), 618.)

at autopsy, and TEE studies report similar figures. A PFO is not similar to an atrial septal defect (ASD), where there is a failure of part of the atrial septum to form rather than fuse, which results in a hole in the septum that separates

the right and left atrium (see Figure 2 and the chapter Atrial Septal Defect). A PFO is not a hole in the heart. Instead, it is a failure of fusion of the two flaps described above which causes a less than 5-mm, slit-like valvular

opening in the interatrial septum (Figure 1). Mechanisms that lead to a marked increase in pressures in the right atrium, such as occur during a Valsalva maneuver or in patients with pulmonary hypertension, can increase the degree of shunting of blood from the right atrium through the slit-like opening of the PFO into the left atrium. This spurt of blood from the right side of the heart through the PFO gains access to the left ventricle, the aorta, and arterial supply to organs of the body. Thus, thrombi that form in the right side of the circulation, from veins in the legs and other areas that drain into the venous circulation to the heart (see the chapter Anatomy of the Heart and Circulation, Figs. 5 and 10), may gain access to the vital organs.

II. CLINICAL FEATURES AND INVESTIGATIONS

Cryptogenic stroke is a nonhemorrhagic stroke (cerebral infarcts) that occurs in younger individuals without identifiable risk factors such as hypertension, diabetes, paroxysmal atrial fibrillation, atheroma of the ascending

aorta, hyperlipidemia, and lacunar strokes from small vessel disease.

No cause for cryptogenic strokes can be defined after intensive investigation which includes a careful cardiovascular and neurologic examination, carotid Doppler, cerebral imaging (CT and MRI), tests for thrombophilic disorders, and Holter monitoring to uncover paroxysmal atrial fibrillation.

Paroxysmal atrial fibrillation can be easily missed, and it is a more common cause of cerebral embolization than that caused by PFOs.

III. PROOF OF PFO INVOLVEMENT IN STROKE

Illustrations depicting PFOs are Figs. 1, 4, and 5 and atrial septal defects, are given in Fig. 2. It is extremely difficult to be certain if a PFO observed by TEE is the cause of stroke in a given individual. There are very few credible reports on this subject. Findings of a thrombus in transit through a PFO have been reported in a few autopsy and echocardiographic reports (see Fig. 4).

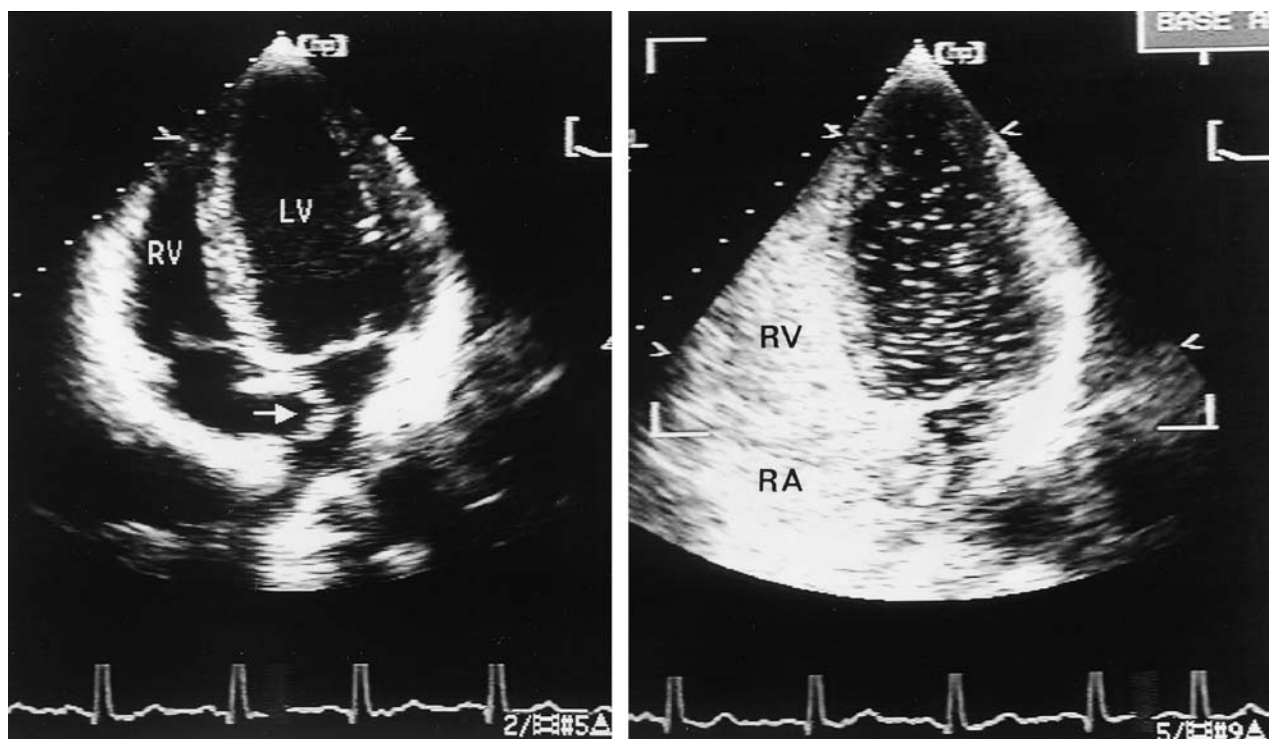

FIGURE 3 Apical four-chamber view recorded in a patient with an atrial septal aneurysm. Note the marked bulging of the atrial septum into the cavity of the left atrium (arrow). The right-hand panel is recorded after injection of saline contrast medium. Note the contrast medium has filled the right ventricular cavity, and there are numerous individual microbubbles seen in the cavity of both the left atrium and left ventricle, consistent with a right-to-left shunt through fenestrations in the atrial septal aneurysm.

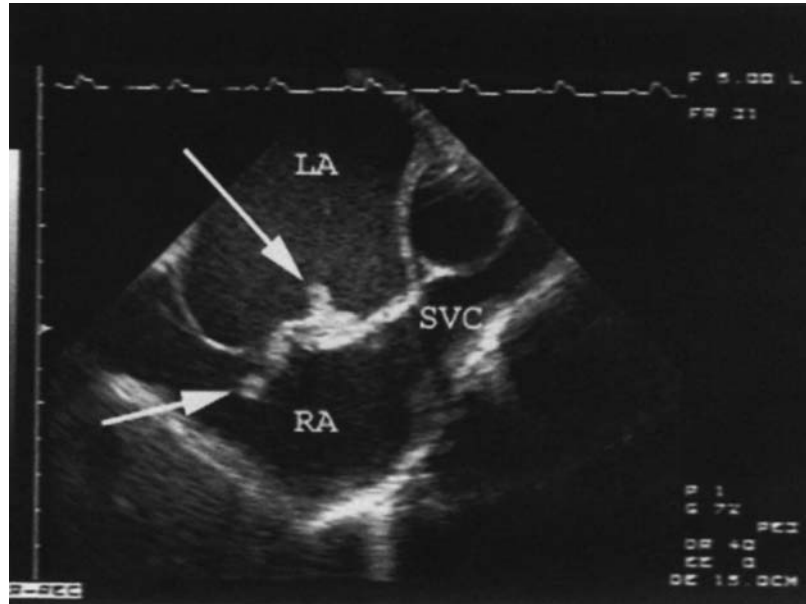

FIGURE 4 Longitudinal transesophageal echocardiographic imaging in the mid-upper esophagus. Arrows point to a thrombus wedged through a patent foramen ovale and lodged in both the right atrium (RA) and left atrium (LA). SVC = superior vena cava. (From Kerut, E. K. et al. (2001). *J. Am. College Cardiol.*, 38(3), 619.)



FIGURE 5 Original patent foramen oval-Star occluder is demonstrated with the center post, the expanded nitinol wires and the two Ivalon sails (left). After implantation the device is shown by transesophageal echocardiography in the vertical biatrial view (middle) and by magnetic resonance imaging in the four-chamber view (right). Ao = aorta; LA = left atrium; RA = right atrium. (Braun, M. U. et al. (2002). *J. Am. College of Cardiol.*, 39(12), 2020.)

The finding of a clot in veins of the lower limbs (deep vein thrombosis, DVT), increases the probability of embolization through the PFO. A DVT has been observed in approximately 33% of individuals with cryptogenic stroke and PFO. It is extremely difficult to be certain of the diagnosis in individuals without DVTs or where predisposing factors for DVT are absent. These predisposing factors include postsurgical immobilization, fractures of the lower limbs, plaster casts applied to the lower limbs, immobilization for several days, and the postpartum state.

A PFO may play a role in other situations such as venous-to-arterial gas embolism in serious forms of severe

decompression sickness in underwater divers and high altitude aviators and astronauts. It may also occur in the platypnea-orthodeoxia syndrome. In this syndrome significant right-to-left shunting of venous blood through a PFO occurs precipitated by postural and other undetermined mechanisms.

Atrial septal aneurysms (ASA; Fig. 3) are associated with PFO. ASA incidence is approximately 1% by autopsy and 2% by TEE. PFO was diagnosed in 70% of stroke patients with an ASA and 75% of controls with an ASA. An ASA is common in patients with unexplained stroke and is more frequently detected by TEE than by

transthoracic echocardiography. An ASA in the absence of a PFO appears to be benign and interventional repair is usually not warranted.

A. Clinical Study: Martin Braun et al.

Study question: This study investigates the safety of transcatheter closure in PFO patients with cryptogenic cerebral ischemia and mid-term follow up of thromboembolic events after closure.

Methods: In this study, 276 consecutive patients with TIA and a history of at least one thromboembolic event had percutaneous PFO closure with the PFO-Star Occluder (see Fig. 5). The mean age of patients was 45 ± 13.7 years, 201 with stroke, and 273 with TIA.

Results: Implantation was successful in all 276 patients. During a 15-month follow up the annual recurrence rate of thromboembolic events was 1.7% for TIA, 0% for stroke, and 0% for peripheral emboli.

Conclusion: The authors of the study concluded that interventional PFO closure with the PFO-Star Occluder device appears to be a promising technique, which results in a low recurrence rate of thromboembolic events in patients with cryptogenic ischemia presumably due to paradoxical embolization. Note that the authors used the word *presumably*. In a study by Hung et al., a 56-year-old patient had a stroke 6 months following device placement that was well seated without residual shunting.

IV. PERSPECTIVE AND RESEARCH IMPLICATIONS

PFOs are very common, but not all PFOs are identical or carry the same risk. Individuals who have PFOs can be grouped according to many PFO characteristics such as large PFOs 0.6–1 cm, versus small PFOs less than 0.6 cm and associated anatomic structures.

The diagnosis of a stroke caused by the presence of a PFO is fraught with danger in the absence of defined thrombi in the veins of the lower limbs and the vena cava that return blood to the right atrium. The investigative techniques for detecting important PFO characteristics and assessing risk of embolic stroke are not clear and require

intensive research. Kerut et al. appropriately stated “the challenge that remains is to determine which PFO and clinical contexts confer an increased risk of significant disease.”

The diagnosis of PFO as a cause for cryptogenic stroke creates a dilemma for neurologists and patients. It is certain that errors in diagnosis are made based on the presumed association of PFO and stroke.

In addition some neurologists often advise aspirin for the prevention of stroke in patients with PFOs. This advice lacks logic because clots that embolize through a PFO must originate in the venous system and such clots are not prevented significantly by the use of aspirin. Anti-coagulants such as warfarin are advisable and superior to aspirin in patients who have sustained a TIA or stroke proven to be caused by paradoxical emboli via a large PFO. Warfarin is also advised in patients with a large PFO with well-defined characteristics that is accompanied by proven thrombi in the venous system seen negotiating the foramen, a rare scenario (see Fig. 4).

In this subset of patients transcatheter closure has a role as outlined above, but cases have been described in which surgical closure has not prevented stroke in patients with PFOs. Anticoagulation with warfarin is advisable for PFO cryptogenic stroke when there is a high probability that the PFO is indicated in paradoxical embolism. Transcatheter device closure should be reserved for the management of PFOs and stroke caused by high-probability paradoxical emboli in individuals with thrombi demonstrated in veins of lower limbs or other veins that drain into the right atrium. If no clots are observed in these veins, PFO as the cause of cryptogenic stroke should be relegated to low probability.

BIBLIOGRAPHY

- Braun, M. U., Fassbender, D., Schoen, S. P. et al. Transcatheter closure or patent foramen ovale in patients with cerebral ischemia. *J. Am. Coll. Cardiol.*, 39:2019–25, 2002.
- Hung, J., Landzberg, M. J., Jenkins, K. J. et al. Closure of patent foramen ovale for paradoxical emboli: Intermediate-term risk of recurrent neurological events following transcatheter device placement. *J. Am. Coll. Cardiol.*, 35:1311–6, 2000.
- Keunt, E. K., Norfleet, W. T., Plotnick, G. D. et al. Patent foramina ovale: A review of associated conditions and impact of physiological size. *J. Am. Coll. Cardiol.*, 38:613, 2001.

Pericarditis and Myocarditis

- I. Pericarditis
- II. Myocarditis

GLOSSARY

- angina** chest pain caused by temporary lack of blood to an area of heart muscle cells, usually caused by severe obstruction of the artery supplying blood to the segment of cells.
- arrhythmia** general term for irregularity or rapidity of the heartbeat, an abnormal heart rhythm.
- heart failure** failure of the heart to pump sufficient blood from the chambers into the aorta; inadequate supply of blood reaches organs and tissues.
- hypotension** marked decrease in blood pressure, usually less than 95 mmHg.
- myocardial infarction** death of an area of heart muscle due to blockage of a coronary artery by blood clot and atheroma; medical term for a heart attack or coronary thrombosis.
- pericarditis** inflammation of the pericardium or sac surrounding the heart; this is not a heart attack.

I. PERICARDITIS

The pericardium is a double membrane that covers the heart and can be involved in infective and noninfective disorders (see Figure 2 in the chapter entitled Anatomy of the Heart and Circulation).

A. Causes

I. Easily Recognizable Underlying Diseases

These include post myocardial infarction pericarditis, which occurs within the first four days of infarction and later after several months; renal failure; neoplastic diseases; tuberculosis; septicemia causing purulent pericarditis; endocarditis; myxedema; collagen vascular diseases such as

rheumatic fever, rheumatoid arthritis, lupus erythematosus, and scleroderma; and trauma that is iatrogenic, postsurgical, or caused by a catheter or pacemaker.

2. Drugs and Radiation

Pericarditis can be caused by cancer chemotherapeutic agents (daunorubicin), dantrolene, hydralazine, isoniazid, minoxidil, procainamide, phenytoin, and anticoagulants. Radiation to the chest may rarely cause pericarditis.

3. Viral Infections

Coxsackie B2, B6 echo virus, HIV, Epstein-Barr, influenza, mumps, varicella, and rubella as well as other viruses, and the mycoplasma organism are all contributing factors to pericarditis. When none of these underlying disorders are present, pericarditis is labeled idiopathic, and in many of these cases an undetected virus may be implicated.

B. Diagnosis

I. Symptoms and Signs

Pericarditis may cause severe chest pain that is located in the retrosternal or left precordial area. Occasionally pain radiates to the trapezius ridge, a radiation that does not occur with angina, but pain may radiate to the neck or left arm and may stimulate angina or myocardial infarction. At times pain is localized to the upper epigastrium and left upper quadrant. Typical features of pain include a sharp, pleuritic pain that increases with deep inspiration, coughing, sneezing, or worsening of pain when lying down. The sharp pain that occurs in bed typically is relieved immediately by sitting and leaning forward or on standing; pain recurs with recumbency.

A pericardial friction rub is heard when a stethoscope is placed between the left sternal edge and the apex

beat, but the rub may be localized to any area of the precordium. The rub is best heard with the diaphragm of the stethoscope pressed firmly against the chest wall with the patient leaning forward holding his breath. The rub may disappear if a pericardial effusion develops.

2. Electrocardiographic Findings

The ECG often shows typical findings that are diagnostic, for example, sinus tachycardia is usually present with widespread ST segment elevation in leads II, III, and aVF and most of V3 to V6. The ST segment is concave upward with no T-wave inversion. Reciprocal ST segment depression is observed in aVR and V1. After a few days the ST segment becomes isoelectric and the T waves flattened. After several days when the ST segment normalizes, diffuse T-wave inversion occurs. After several weeks the T waves normalize and rarely remain inverted.

C. Viral Pericarditis

The viruses implicated include: Coxsackie, echo, Epsstein-Barr, influenza, HIV, mumps, rubella and varicella. The majority of cases of so-called idiopathic pericarditis are caused by viral infections. Patients with these infections are usually hospitalized and monitored for the development of pericardial effusion. Pericardiocentesis is rarely necessary, but effusion may lead to cardiac tamponade.

D. Cardiac Tamponade

Cardiac tamponade is manifested by hemodynamic compromise, elevation of the jugular venous pressure, and pulsus paradoxus that may be masked by severe hypotension. Presenting symptoms include severe shortness of breath, chest tightness, dysphagia, and a shock-like state. Hemodynamic compromise may be life-threatening.

Echocardiography usually confirms the diagnosis with an early finding of diastolic right atrial collapse, which occurs in most cases except in regional tamponade where right or left atrial collapse may be observed. Also seen on echocardiography is diastolic right ventricular collapse. A swinging heart may also be observed associated with electrical alternans.

Management of cardiac tamponade involves the maintenance of an adequate preload to generate stroke volume. Thus, diuretics and preload reducing agents such as nitrates and ACE inhibitors must be avoided. Volume expansion with saline and even transfusion of packed red cells may provide hemodynamic stability until

lifesaving pericardiocentesis is achieved. Reaccumulation of fluid and tamponade are indications for a subxiphoid pericardial window drainage carried out by a cardiothoracic surgeon.

E. Constrictive Pericarditis

Constrictive pericarditis causes a restriction to cardiac filling and is the most common cause of a restrictive syndrome.

I. Symptoms and Signs

Shortness of breath, tiredness, and swelling of the abdomen due to ascites as well as other symptoms of underlying disease cause pericardial constriction. The presence of moderate ascites occurring weeks or months before the presence of significant leg edema points strongly to constrictive peritonitis and serves to distinguish the condition from heart failure in which prominent leg edema occurs followed months later by mild ascites.

Examination of the neck veins reveals a markedly elevated jugular venous pressure with paradoxical inspiratory increase in jugular vein distension (Kussmaul's sign).

The venous pulse has a prominent y-descent (a major negative wave), coincident with the rapid diastolic filling of the ventricle. A prominent x-descent, coincident with filling of the atrium is often observed in patients with sinus rhythm. The exaggerated x- and y-descents give the venous pressure wave a characteristic M- or W-shaped pattern. A characteristic high-frequency, early occurring third heart sound (a pericardial knock) should alert the physician to the diagnosis of pericarditis. The pericardial knock sound is caused by cessation of diastolic filling. The knock occurs earlier than the conventional third heart sound of heart failure and has a sharp, high-pitched quality that is easily heard with the diaphragm of the stethoscope. The knock sound may mimic an opening snap characteristic of mitral stenosis or an early filling sound heard in endomyocardial fibrosis.

The presentation and investigational findings of constrictive pericarditis and restrictive cardiomyopathy resemble each other and differentiation is often challenging. Atrial fibrillation occurs in approximately 33% of cases of constrictive pericarditis.

2. Management

When symptoms are persistent and bothersome and medical therapy with the judicious use of diuretics and

digitalis to control the ventricular response in patients fails, then surgical pericardiectomy becomes necessary.

II. MYOCARDITIS

Acute myocarditis is a disorder that can cause a fulminant illness resulting in severe functional impairment or death. Myocarditis appears to be a precursor to dilated cardiomyopathy in some patients.

A. Causes

Acute myocarditis has been associated with infection by Coxsackie B3 and B5, mumps, Epstein-Barr, and influenza as well as other viruses. In approximately 50% of patients with HIV who developed dilated cardiomyopathy, associated myocarditis was observed on biopsy. In more than 50% of HIV patients myocarditis was observed at autopsy. HIV or cytomegalovirus appears to be the cause of myocarditis in patients with AIDS.

Chagas disease is the most common cause of myocarditis in Latin America and is caused by toxoplasmosis and diphtheria. Acute myocarditis is associated with lupus erythematosus and Kawasaki syndrome. Forms of giant cell infiltration of the myocardium may occur with Sjogren's syndrome, giant cell arteritis, thymoma, myasthenia gravis, chronic active hepatitis, and ulcerative colitis. Patients with giant cell myocarditis appear to have a prognosis worse than that of lymphocytic myocarditis. Hypersensitivity to drugs and other exogenous agents may also cause myocarditis.

B. Symptoms and Signs

Major manifestations include chest pain in more than 20% of patients associated with peritonitis. Chest pain may occur suddenly and last for several hours without features of pericarditis and mimic acute myocardial infarction. Patients may have recurrent or intractable chest pain over several days. Abnormal heart rhythms may cause palpitations in approximately 33%. The disease may precipitate

heart failure and signs and symptoms of heart failure may occur.

An easily heard third heart sound gallop (S3) is often present and is an unexpected finding in patients with significant myocardial involvement. The loud third heart sound may persist for several weeks. Very minimal symptoms may be present and the commencement of the disease may go unnoticed until severe damage to the heart muscle causes signs of heart failure.

ECG shows nonspecific ST-T wave changes, often with low-voltage QRS complexes. Atrial and ventricular premature beats with supraventricular tachycardia are a common occurrence. Ventricular tachycardia may cause a life-threatening situation. Q waves simulating acute myocardial infarction but without much ST segment elevation may be seen on ECG, but serial ECGs from several hours to a few days do not show the evolutionary changes that are hallmarks of acute myocardial infarction. Cardiac enzymes, CK-MB, and troponins may simulate acute myocardial infarction, but with a different time course.

C. Management

More than 85% of patients completely recover over several months. In a few cases heart failure is manifested and clears over several weeks with conventional medical therapy. If heart failure becomes progressively worse, it may be ameliorated with administration of corticosteroids and cyclosporine. In the presence of lethal or potentially lethal arrhythmias the administration of amiodarone may be lifesaving.

BIBLIOGRAPHY

- Garcia, M. J. Constriction vs. Restriction: How to evaluate? *J. Am. Coll. Cardiol., ACC J. Rev.*, July/August, 49-53, 2003.
- Khan, M. Gabriel Pericarditis/cardiac tamponade. *On Call Cardiology*. W. B. Saunders, Philadelphia, 2001.
- Khan, M. G. In *Heart Disease Diagnosis and Therapy: Pericarditis*, second edition. Humana Press, New Jersey, 2005.
- Lange, R. A., Hillis, L. D. et al. Acute pericarditis. *N. Engl. J. Med.*, 351:2195-2202, 2004.

Pulmonary Arterial Hypertension

- I. Pulmonary Hypertension
- II. Primary Pulmonary Hypertension

GLOSSARY

ascites accumulation of serous fluid in the abdominal cavity.
dyspnea shortness of breath, usually on exertion.
heart failure failure of the heart to pump sufficient blood from the chambers into the aorta; inadequate supply blood reaches organs and tissues.
syncope temporary loss of consciousness caused by lack of blood supply to the brain; fainting describes a simple syncopal attack.
tachypnea increased respiratory rate.

I. PULMONARY HYPERTENSION

In 1998, the World Health Organization (WHO) classified primary pulmonary hypertension (PPH) as one of the causes of pulmonary arterial hypertension (PAH). PPH was defined in the U.S. National Institutes of Health Registry as a mean pulmonary artery pressure of more than 25 mmHg at rest or 30 mmHg with exertion, in the absence of heart disease, chronic thromboembolic disease, underlying pulmonary disorder, or other secondary causes.

A. Causes and Risk Factors

An approach to the elucidation of the many secondary causes of PAH is given in Fig. 1. PAH may be caused by several disorders that include:

- Pathophysiologic causes of severe chronic hypoxemia including alveolar hypoventilation disorders such as chronic obstructive pulmonary disease (COPD), numerous restrictive lung diseases, chronic exposure to high altitude, and sleep apnea
- Diseases primarily of the lung parenchyma that also affect the abundant pulmonary vascular network such

as emphysema and collagen vascular diseases like scleroderma, sarcoidosis, and schistosomiasis

- Pulmonary venous hypertension in which the pulmonary capillary wedge pressure is increased, chronic severe left ventricular failure, severe mitral stenosis, severe mitral regurgitation, left atrial myxoma, and pulmonary veno-occlusive disease
- Diseases that cause a marked increase in resistance in the pulmonary arteries and large arterioles such as pulmonary embolism, *in situ* thrombosis of pulmonary arteries, congenital heart disease caused by shunts, sickle cell disease, schistosomiasis, and sarcoidosis
- Drugs such as appetite suppressants [fenfluramine, dexfenfluramine, aminorex] and toxins including toxic rapeseed oil
- PPH is considered when all secondary causes are excluded

A most publicized risk factor for PAH is appetite suppressant drugs. Aminorex fumarate was linked to an epidemic of PAH in Switzerland, Germany, and Austria in the sixties, and withdrawal of this agent was followed by a fall in incidence of the disorder. The use of fenfluramine and its derivatives in Europe caused an increase in PAH cases. The combination of fenfluramine and phentermine in the United States has been implicated, and toxic rapeseed oil caused several cases in Spain.

B. Symptoms and Physical Signs

Mild pulmonary hypertension with a mean pulmonary artery pressure less than 25 mmHg is usually asymptomatic. A moderate degree of pulmonary hypertension with a pulmonary artery pressure of 50–60 systolic with a mean greater than 40 mmHg may cause dyspnea on exertion and easy fatigability. Severe pulmonary hypertension with a pulmonary artery pressure greater than 80 and a mean greater than 55 mmHg may cause severe and bothersome dyspnea and is nearly always present. In the U.S. National Institutes of Health Registry, 98% of patients with PPH had dyspnea at enrollment. Less common symptoms

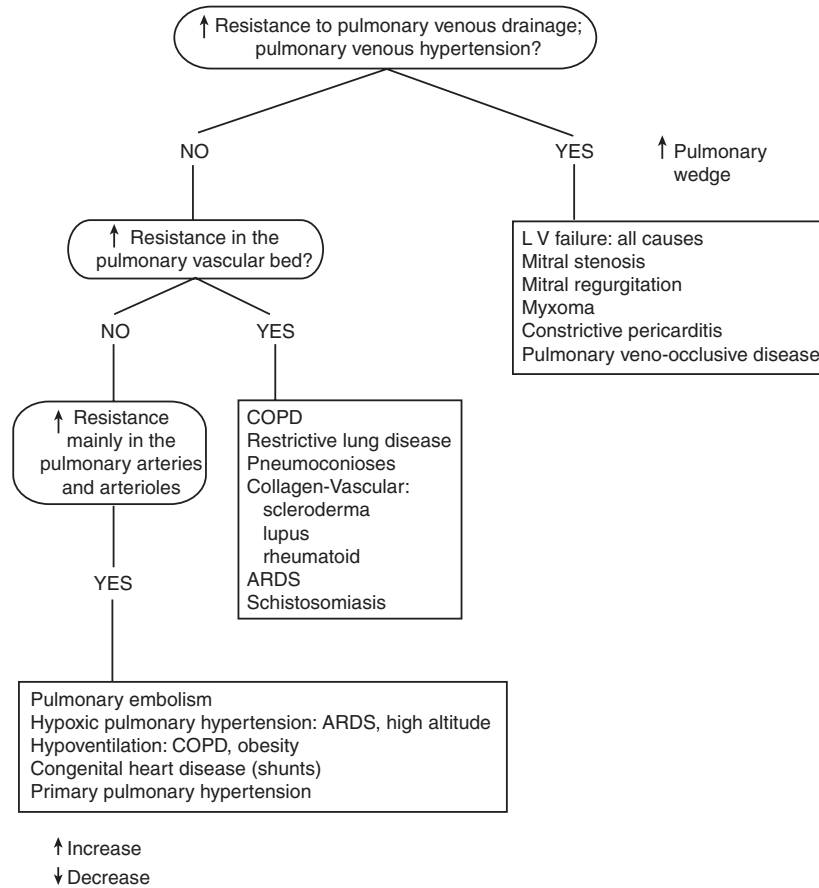

FIGURE 1 Common causes of pulmonary hypertension.

include tachypnea, chest pain, presyncope, syncope, palpitations, peripheral edema, and rarely sudden death.

Abnormal physical signs or examination include a giant A wave in the jugular venous pulse. A left parasternal lift is seen and felt along the left sternal border caused by right ventricular hypertrophy. There is accentuation of the pulmonary component of the second heart sound, an ejection click caused by dilation of the main pulmonary artery, and right-sided third and fourth heart sounds. A murmur of pulmonary regurgitation and tricuspid regurgitation with prominent V waves is observed if the tricuspid valve annulus is dilated. Finally, signs of right heart failure occur with jugular venous pressure elevation, ascites, and edema.

C. Laboratory Studies

1. Chest X-ray and CT Scan

Chest x-ray may show evidence of diseases that causes secondary PAH. With significant PPH the lung fields are clear with evidence of dilation of the main right and left

pulmonary arteries and attenuation of peripheral branches, but the chest x-ray is nonspecific. A CT may be helpful in resolving restrictive lung disease, other parenchymal lung diseases, or mediastinal fibrosis.

2. Electrocardiogram and Echocardiography

The ECG is nearly always abnormal in patients with significant PAH from any cause and may reveal evidence of right atrial hypertrophy, right axis deviation, and sometimes right ventricular hypertrophy or ST-segment depression with T-wave inversion in leads V1 to V3. Echocardiographic assessment is most valuable in detecting causes of left heart failure, left atrial enlargement, mitral stenosis, left atrial myxoma, elevation of the pulmonary artery pressure, right ventricular hypertrophy, tricuspid regurgitation, enlargement of cardiac chambers, shunts, and right ventricular dimensions and function.

3. Other Studies

The lung scan is nondiagnostic and must be analyzed in conjunction with the clinical assessment and chest x-ray.

In the absence of chronic obstructive lung disease, the lung scan may help in differentiating chronic pulmonary embolism from PPH. A complete blood count should include HIV antibody, liver function tests, thyrotropin, and an antinuclear antibody. To exclude other secondary causes of pulmonary hypertension, a sleep study and pulmonary angiography should be performed.

II. PRIMARY PULMONARY HYPERTENSION

The frequency of PPH is estimated as one to two cases per million people. This rare disease is often fatal and frequently occurs in young women who are affected twice as often as male individuals. There appears to be a marked frequency observed in the Indian subcontinent. The disease presents in the third decade of life in women and the fourth decade in men with a mean age at diagnosis of 36 years with a prevalence close to 10%. PPH accounts for less than 0.5% of all cases of PAH.

A. Diagnosis

A thorough history and physical examination and assessment of the laboratory tests outlined above should exclude

secondary causes of PAH. Right heart catheterization in patients with PPH gives accurate hemodynamic measurements and appraisal of disease severity and prognosis. Increasing mean pulmonary artery pressure, right atrial pressure, and decreased cardiac index are associated with decreased survival rates. A mean pulmonary artery pressure less than 55 or greater than 85 mmHg indicates a fair and poor prognosis, respectively. A mean right atrial pressure less than 10 mmHg or greater than 20 mmHg indicates a good and bad prognosis, respectively. A mean cardiac index greater than 4 L/minute/m² (4 L/min/m²) or less than 2 L/minute/m² indicates good and poor prognosis, respectively.

B. Risk Factors and Pathogenesis

A proposed pathogenesis for the development of PPH is given in Fig. 2. Key factors include genetics and endothelial injury and dysfunction. Studies indicate an autosomal dominant inheritance, estimated penetrance of 10–20% and the onset of the disorder occurs at an earlier age in successive generations. A study of families affected by PPH revealed *BMPR2* as a primary gene for familial PPH on chromosome 2q33. Mutations in *BMPR2* have

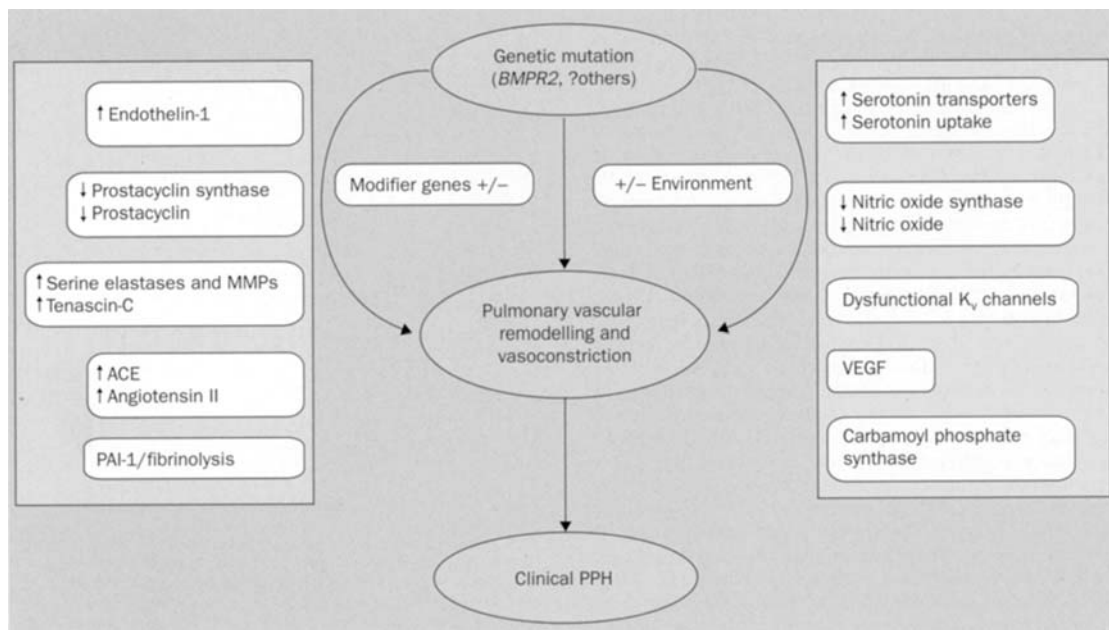

FIGURE 2 Proposed pathogenesis for the development of PPH. Genes implicated in the pathogenesis of PPH are prostacyclin synthase, serotonin transporters, nitric oxide synthase, serine elastases, and matrix metalloproteinases (MMPs), voltage-gated potassium (K_v) channels, angiotensin-converting enzyme (ACE), vascular endothelial growth factor (VEGF), carbamoyl phosphate synthase, and plasminogen activator inhibitor type 1 (PAI-1). Endothelin-1 production adds to the vasoconstriction in PPH, but whether this is secondary to changes in the above genes, a result of endothelial dysfunction, or a primary pathogenetic event is not clear. Pulmonary vascular remodeling results from the effects of genetics, modifying genes, and environment. (From *The Lancet*, 361, 1536, 2003.)

been noted in approximately 50% of familial PPH cases and 26% of sporadic cases.

Endothelial injury and dysfunction also appear to be key pathogenic factors. There is strong evidence that points to an abnormality in the pulmonary vascular endothelium. Increased pulmonary vascular reactivity and vasoconstriction observed in individuals with PPH indicate that a marked vasoconstrictor tendency is an important pathogenic factor in predisposed individuals.

Hypovasodilatation appears to be the result of loss of endothelial cell integrity. A defect in the nitric oxide synthase system appears to be implicated. Vascular endothelial cells synthesize nitric oxide from L-arginine. Patients with PPH appear to be deficient in the endothelial-derived vasodilator prostacyclin and nitric oxide. Nitric oxide is made by vascular endothelium and catalyzed by nitric oxide synthase which inhibits smooth muscle cell growth. Endothelium from patients with PPH showed negligible chemical staining for nitric oxide synthase compared with healthy controls. An increase in the production of thromboxane, a powerful vasoconstrictor, and decrease in formation of the powerful vasodilator prostacyclin have been documented.

Increased expression of endothelin-1, a potent vasoconstrictor, and mitogen for smooth muscle cells in the pulmonary artery of patients appears to be related to disease severity and survival.

Serotonin plasma levels are higher than normal in PPH probably as a result of normal platelet processing and storage. Appetite suppressant drugs serve as substrates for serotonin transporters and gain access into pulmonary artery smooth muscle cells. The toxic action on smooth muscle cells is perhaps the link between anorectic agents and development of PPH.

Voltage-gated potassium channels in pulmonary artery smooth muscle cells appear to be blocked by anorectic agents, thus, causing enhanced smooth muscle cell proliferation and vasoconstriction.

C. Therapy

I. Calcium Antagonists

Less than 25% of patients with a mild-to-moderate degree of PPH treated with calcium antagonists obtain sustained hemodynamic improvement and survival. A trial of calcium antagonists is indicated in patients who respond to acute vasodilator testing with nitric oxide, adenosine, or prostacyclin. Vasodilator testing is done with short-acting agents because serious complications including hypotension and death have occurred.

2. Prostacyclin

Several studies have demonstrated improvement in exercise tolerance, hemodynamic measurements, and survival in patients treated with intravenous epoprostenol. Although this agent is considered effective, its short half-life requires continuous long-term intravenous treatment via an indwelling catheter. Complications are common and include local and systemic infection, hemorrhage, paradoxical embolism, and rarely fatalities because of delivery malfunction. Most important, patients without response to vasodilator testing may obtain benefit from this therapy because of decreased platelet aggregation, factor VIII, von Willebrand antigen, and production of endothelin-1.

Oral analogues of epoprostenol are being tested. Beraprost, administered orally and tested in a randomized clinical trial of 12 weeks in patients with PAH functional class II–III, showed improved exercise tolerance and dyspnea in patients with PPH. Iloprost administered by inhalation surprisingly caused more potent pulmonary arterial vasodilatation than inhaled nitric oxide.

3. Endothelin-1 Receptor Antagonists

Endothelin-1 is a potent endogenous vasoconstrictor and smooth muscle mitogen that is overexpressed in the plasma and lung tissue of patients with PPH. Two multicenter, randomized clinical trials have shown proven benefits of an oral endothelin-1 receptor antagonist, bosentan. This agent is indicated for stable functional class III or IV patients with PAH.

a. Clinical Study: Rubin et al.

Methods: This study randomly assigned 213 patients with PPH (all associated with connective tissue disease) to receive 6.25 mg then 125 or 250 mg of bosentan or placebo for a minimum of 12 weeks. The primary end point was the degree of change in exercise capacity.

Results: At 16 weeks patients treated with this agent showed an improved six-minute walking distance; the mean difference between the placebo group and the combined bosentan group was 44 m ($p=0.0001$).

The drug modestly improved the dyspnea index, WHO functional class, and increased the time to clinical worsening. At 16 weeks 38 and 34% of patients, respectively, had improved from class III to II. A significant number of placebo patients improved their class because of the exercise program and encouragement to walk. The drug was discontinued in 2% of patients because of liver dysfunction. Increasing the dose to 250 mg twice daily lead

to a greater frequency of increased aminotransferase levels. Caution is necessary because the drug can precipitate hepatocellular injury, particularly at high doses. Selective antagonists of the endothelin (Eta) receptor are being investigated, but sitaxsentan administration at high doses has been associated with fatal hepatitis.

4. Phosphodiesterase Inhibitors

Acutely, oral sildenafil causes a reduction in mean pulmonary artery pressure in patients with PPH. Sildenafil is a selective inhibitor of cyclic GMP-specific phosphodiesterase type V; the main phosphodiesterase in the pulmonary vascular bed. Urinary excretion of cyclic GMP has been noted to be high in patients with PPH which correlates with the severity of disease. Sildenafil combination therapy with prostacyclin analogues and endothelin-1 receptor antagonists is being tested in clinical trials.

5. Statins

The cholesterol-lowering agent, 3-hydroxy-3-methylglutaryl coenzyme A (statins), prevents hypoxia-mediated downregulation of endothelial nitric oxide synthase. It does this by stabilizing its mRNA and repressing vascular smooth muscle cell proliferation in response to platelet-derived growth factor and vascular injury. Statins have been shown to attenuate hypoxic pulmonary hypertension in rats.

6. L-Arginine

L-arginine is necessary for the production of the potent vasodilator nitric oxide, and L-arginine supplementation is being investigated in combination with other agents in patients with PAH. In a small placebo-controlled trial in patients with PAH, L-arginine administration for one week improved maximum oxygen consumption during exercise.

7. Lung Transplantation

Indications for lung transplantation include disabled patients, functional class IV despite optimal medical therapy, a cardiac index of less than 2 L/minute/m², right atrial pressure greater than 15 mmHg, and mean pulmonary artery pressure greater than 55 mmHg. Recent advances in medical therapy will limit the need for lung transplantation.

BIBLIOGRAPHY

- Abenham, L., Moride, Y., Brenot, F. et al. For the international primary pulmonary hypertension study group. Appetite suppressant drugs and the risk of primary pulmonary hypertension. *N. Engl. J. Med.*, 335:609–16, 1996.
- Badesch, D. B., McLaughlin, V. V., Delcroix, M. et al. Postanoid therapy for pulmonary arterial hypertension. *J. Am. Coll. Cardiol.*, 43:56S–61S, 2004.
- Barst, R. J., Rubin, L. J., Long, W. A. et al. A comparison of continuous intravenous epoprostenol (prostacyclin) with conventional therapy for primary pulmonary hypertension. *N. Engl. J. Med.*, 334:296–301, 1996.
- Barst, R. J., Rubin, L. J., McGoan, M. D. et al. Survival in primary pulmonary hypertension with long-term continuous intravenous prostacyclin. *Ann. Intern. Med.*, 121:409–15, 1994.
- Channick, R. N., Sitbon, O., and Barst, R. J. Endothelin receptor antagonists in pulmonary arterial hypertension. *J. Am. Coll. Cardiol.*, 43:62S–67S, 2004.
- Chockalingam, A., Gnanavelu, G., Venkatesan, S. et al. Efficacy and optimal dose of sildenafil in primary pulmonary hypertension. *Int. J. Cardiol.*, 99:91–95, 2005.
- Eddahibi, S., Humbert, M., Fadel, E. et al. Serotonin transporter overexpression is responsible for pulmonary artery muscle hyperplasia in primary pulmonary hypertension. *J. Clin. Invest.*, 108:1141–50, 2001.
- Gain, S. et al. Pulmonary hypertension: Grand rounds. *JAMA*, 284:3160–3168, Dec 2000.
- Garcia-Dorado, D., Miller, D. D., Garcia, E. J. et al. An epidemic of pulmonary hypertension after toxic rapeseed oil ingestion in Spain. *J. Am. Coll. Cardiol.*, 1:1216–22, 1983.
- Ghofrani, H. A., Pepke, J., Barbera, J. A. et al. Nitric oxide pathway and phosphodiesterase inhibitors in pulmonary arterial hypertension. *J. Am. Coll. Cardiol.*, 43S:68S–72S, 2004.
- Ghofrani, H. A., Wiedemann, R., Rose, R. et al. Combination therapy with oral sildenafil and inhaled iloprost for severe pulmonary hypertension. *Ann. Intern. Med.*, 136:512–22, 2002.
- Ghofrani, H. A., Wiedemann, R., Rose, F., Schermuly, R. T. et al. Sildenafil for treatment of lung fibrosis and pulmonary hypertension: A randomised controlled trial. *Lancet*, 360:9337, 895–900, 2002.
- Hoepfer, M. M., Olschewski, H., Ghofrani, H. A. et al. A comparison of the acute hemodynamic effects of inhaled nitric oxide and aerosolized iloprost in primary pulmonary hypertension. *J. Am. Coll. Cardiol.*, 35:176–82, 1999.
- Hinderliter, A. L., Willis, IV, P.W., Barst, R. J. et al. Effects of long-term infusion of prostacyclin (epoprostenol) on echocardiographic measures of right ventricular structure and function in primary pulmonary hypertension. *Circulation*, 95:1479–1486, Mar 1997.
- Humbert, M., Morrell, N. W., Archer, S. L. et al. Cellular and molecular pathobiology of pulmonary arterial hypertension. *J. Am. Coll. Cardiol.*, 43:13S–24S, 2004.
- Ichinose, F., Roberts, Jr, J. D., Zapol, W. M. et al. Inhaled nitric oxide: A selective pulmonary vasodilator: Current uses and therapeutic potential. *Circulation*, 109:3106–3111, Jun 2004.
- Indolfi, C., Cioppa, A., Stabile, E. et al. Effects of hydroxy methylglutaryl coenzyme A reductase inhibitor simvastatin on smooth muscle cell proliferation *in vitro* and neointimal formation *in vivo* after vascular injury. *J. Am. Coll. Cardiol.*, 35:214–21, 2000.
- Mark, E. J., Patalas, E. D., Chang, H. T. et al. Fatal pulmonary hypertension associated with short-term use of fenfluramine and phentermine. *N. Engl. J. Med.*, 337:602–06, 1997.

- Newman, J. H. Treatment of primary pulmonary hypertension — the next generation. *N. Engl. J. Med.*, 346:933–35, 2002.
- Pietra, G. G., Capron, F., Stewart, S. et al. Pathologic assessment of vasculopathy used in pulmonary hypertension. *J. Am. Coll. Cardiol.*, 43:25S–32S, 2004.
- Preston, I. R., Tang, G., Tilan, J. U. et al. Retinoids and pulmonary hypertension. *Circulation*, 111:782–790, 2005.
- Rich, S., McLaughlin, V. V. et al. Review: Cardiovascular drugs: Endothelin receptor blockers in cardiovascular disease. *Circulation*, 108:2184–2190, Nov 2003.
- Royhman, R. B., Ayestas, M. A., Dersch, C. M. et al. Aminorex, fenfluramine, and chlorphentermine are serotonin transporter substrates; implications for primary pulmonary hypertension. *Circulation*, 100:869–75, 1999.
- Rubin, L. J., Badesch, D. B., Barst, R. J. et al. Bosentan therapy for pulmonary arterial hypertension. *N. Engl. J. Med.*, 346:896–903, 2002.
- Runo, J. R., and Lloyd, J. E. Primary pulmonary hypertension. *Lancet*, 361:1533–44, 2003.
- Simmoneau, G., Galie, N., Rubin, L. J. et al. Clinical calcification of pulmonary hypertension. *J. Am. Coll. Cardiol.*, 43:5S–12S, 2004.
- Williamson, D. J., Wallman, L. L., Jones, R. et al. Hemodynamic effects of bosentan, an endothelin receptor antagonist, in patients with pulmonary hypertension. *Circulation*, 102:411–418, Jul 2000.
- Yuan, J. X. J., Rubin, L. J. et al. Pathogenesis of pulmonary arterial hypertension: The need for multiple hits. *Circulation*, 111:534–538, 2005.

Pulmonary Embolism

- I. Incidence
- II. Pathogenesis
- III. Pathophysiology
- IV. Diagnosis
- V. Investigations
- VI. Management

GLOSSARY

- hypocapnia** deficiency of carbon dioxide in the blood.
hypoxia low levels of oxygen in the blood (hypoxemia).
tachypnea increased respiratory rate.
thrombocythemia increased levels of circulating blood platelets.

I. INCIDENCE

In the United States the incidence of pulmonary embolism has been estimated to exceed 650,000 cases per year. A common and difficult problem, pulmonary embolism is the third most common cause of death in United States.

- Pulmonary embolism accounts for up to 100,000 deaths annually and approximately 33% of the deaths occur within one hour of the onset of symptoms.
- The diagnosis is not suspected in more than 50% of patients who die and symptoms may mimic a heart attack.
- Approximately 10% of patients with pulmonary embolism die in the first hour and another 20% will die later in the course of the illness.
- When a timely diagnosis is made more than 80% of patients will survive.
- When pulmonary embolism is overlooked, more than 30% of cases will result in death. Prevention, early diagnosis, and treatment of this serious disease are vital.

II. PATHOGENESIS

Pulmonary emboli arise from a number of sites, but the primary sources are the deep iliofemoral and thigh veins. Other sites include the pelvic veins and less commonly the

right atrium and ventricle. The calf veins do not usually give rise to significant emboli but may extend upward into the thigh in more than 20% percent of cases (see chapter entitled Deep Vein Thrombosis).

Risk factors include any processes that increase venous stasis damage the intima of the venous system, and cause a hypercoagulable state. High-risk clinical conditions and underlying factors include:

- History of thromboembolic disease
- Prolonged anesthesia associated with surgery
- Surgery or injury to the lower extremities or hip
- Surgical treatment triggers an increase in factor VIII and a decrease in protein C activity and an increase in plate adhesiveness
- Immobilization after a fracture or surgery, myocardial infarction, heart failure, or stroke
- Pregnancy, particularly in the early postpartum phase and also the use of estrogen-containing compounds
- Malignancy, tumor cells appear to interact with thrombin and plasmin-generating systems; some cancer causes a decrease in platelet antithrombin and antithrombin III activities and cause an increase in fibrinogen
- Street drugs that increase platelet count and adhesiveness
- Hypercoagulable diathesis, protein C, S, or antithrombin III deficiency, polycythemia vera, and thrombocythemia are implicated in less than 15% of cases of deep vein thrombosis; rarely high levels of factor V or factor VII may be underlying factors
- Patients with primary or secondary antiphospholipid syndrome

III. PATHOPHYSIOLOGY

The effects of pulmonary emboli on gas exchange are multifold:

- During increase in alveolar dead space there is ventilation of the dead space that receives no blood flow
- Bronchoconstriction and loss of alveolar surfactant in the area of embolus
- Hyperventilation
- Hypoxemia

Hemodynamic effects of pulmonary emboli depend not only on the size of embolus but also on the patient's baseline cardiopulmonary status. Normal individuals can tolerate an embolic event of substantial size without significant changes in pulmonary artery pressures. Pulmonary hypertension may occur when 30% or more of the pulmonary vascular bed is obstructed. In patients with significant underlying cardiopulmonary disease, however, smaller emboli can result in cor pulmonale if acute elevations of the mean pulmonary arterial pressure exceed 40 mmHg. In the patient with no pre-existing cardiopulmonary disease, shock is usually precipitated by obstruction of more than 50% of the pulmonary circulation.

IV. DIAGNOSIS

The diagnosis of pulmonary embolism should be strongly considered in patients who manifest one or more of the following clinical patterns.

- Central chest pain: This can be accompanied by acute shortness of breath, tachypnea, and syncope or presyncope. Symptoms may mimic a heart attack
- Acute unexplained dyspnea: Patients present with acute shortness of breath, tachypnea, and tachycardia but these three findings may be transient. Tachypnea and tachycardia are sustained in patients with massive embolism. Unexplained dyspnea accompanied by syncope may occur.
- Pulmonary infarction: Patients usually have sustained a submassive embolus. Most of these patients have pleuritic chest pain, dyspnea, and hemoptysis. Chest x-ray reveals an infiltrate, pleural-based consolidation. A small pleural effusion blunting the costophrenic angle is a suspicious sign in a patient with an acute shortness of breath.
- Acute cor pulmonale and cardiogenic shock: Acute right ventricular dilatation and right heart failure supervene.
- Findings on examination of the patient are usually nonspecific and are often nondiagnostic.

The combination of the probability from clinical assessment (PCA), the result of D-dimer and lung scan may indicate a diagnosis of embolism and should suggest the need for venography of the thigh veins and for pulmonary angiograms to confirm the diagnosis (see Fig. 1).

V. INVESTIGATIONS

A. Arterial Blood Gas Analysis

Acute respiratory alkalosis is the most common finding. Carbon dioxide retention only occurs with massive

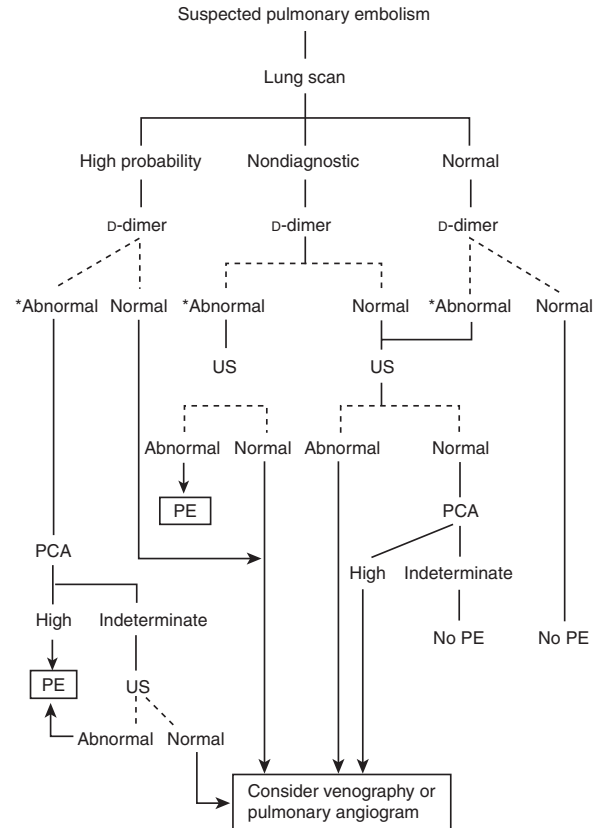

FIGURE 1 Algorithm for the diagnosis of suspected pulmonary embolism (PE). PCA=probability from clinical assessment; US=ultrasonography of the veins of the lower limbs; *=exclude myocardial infarction, congestive heart failure, pneumonia, cancer, post-surgery. (From Khan, M. Gabriel (2001). *On Call Cardiology, 2nd ed.*, Philadelphia: W. B. Saunders, p. 247.)

embolism. Because tachypnea and hyperventilation commonly occur, carbon dioxide is washed out from alveoli; thus, hypocapnia and hypoxemia may occur and these two findings in association with a normal chest x-ray increases the likelihood of embolism. The absence of acute respiratory alkalosis should not be taken as evidence against the diagnosis of pulmonary embolism. A normal blood gas result does not exclude embolism. In general, blood gas analysis is most often unhelpful.

B. Elisa

Degradation products of the pulmonary clot contain D-dimers that are released and can be detected in the plasma by monoclonal antibodies. A D-dimer enzyme-linked immunosorbent assay (ELISA) greater than 500 ng/ml 500 µg/L is abnormal and is present in more than 90% of patients with pulmonary embolism. The sensitivity is about 96% and the negative predictive value is about 99%. The test is highly sensitive but not specific for

the diagnosis. Other conditions that give a positive result should be excluded, particularly myocardial infarction, congestive heart failure, pneumonia, cancer, and post surgery. A normal test result gives reassurance in more than 97% of cases that embolism is not present.

C. Electrocardiogram

This shows a sinus tachycardia and sometimes transient abnormal T-wave inversion in leads V1 to V4 (right ventricular strain pattern) or transient right bundle branch block; these are nonspecific findings.

D. Lung Scan

The lung scan is interpreted as one of the following:

- Normal: A normal scan in the patient with a normal D-dimer indicates an absence of pulmonary embolism in more than 99% of cases
- Nondiagnostic (intermediate and low-probability scans)
- High probability: This is indicated by multiple segmental perfusion defects without corresponding ventilation abnormalities. A high-probability scan is about 97% specific for embolism but lacks sensitivity.

E. Venous Ultrasonography

A normal result does not exclude deep vein thrombosis or embolism. More than 20% of patients with a normal study have proven pulmonary embolism.

F. Pulmonary Angiogram

This test is necessary in patients with a nondiagnostic lung scan and a negative femoral venogram if the PCA is high

and strongly indicative that embolism is present. The test is useful in patients with a high-probability scan and a high risk of bleeding with use of anticoagulants.

VI. MANAGEMENT

Heparin is administered intravenously in a bolus of 5000–10,000 U followed by a continuous infusion to achieve a partial thromboplastin time (PTT) of 60–80 seconds, 1.5 to 2 times the patient control level. Thrombolytic therapy is of value to restore circulation in patients with hemodynamic compromise in the setting of massive emboli or cardiogenic shock. Caution is required, however, because patients with pulmonary embolism have a very high risk of intracranial hemorrhage following thrombolytic therapy. Embolectomy is reserved for patients with massive embolism and hypotension who have not responded to conventional therapy.

BIBLIOGRAPHY

- Goldhaber, S. Z. Pulmonary embolism. *Lancet*, 363:1295–1305, 2004.
- Goldhaber, S. Z., Fanikos, J. et al. Prevention of deep vein thrombosis and pulmonary embolism. *Circulation*, 110:e445–e447, 2004.
- Nakamura, M., Nakanishi, N., Yamada, N. et al. Effectiveness and safety of the thrombolytic therapy for acute pulmonary thromboembolism: Results of a multicenter registry in the Japanese Society of Pulmonary Embolism Research. *Int. J. Cardiol.*, 99:91–95, 2005.
- PIOPED Investigators: Value of the ventilation perfusion scan in acute pulmonary embolism. *JAMA*, 263:2753, 1990.
- Punukollu, H., Khan, I. A., Punukollu, G. et al. Acute pulmonary embolism in elderly: Clinical characteristics and outcome. *Int. J. Cardiol.*, 99:213–216, 2005.
- Punukollu, G., Khan, I. A., Gowda, R. M. et al. Cardiac troponin I release in acute pulmonary embolism in relation to the duration of symptoms. *Int. J. Cardiol.*, 99:207–211, 2005.

Race and Cardiovascular Disease

- I. Hypertension
- II. Heart Failure
- III. Coronary Artery Disease and Stroke

GLOSSARY

ejection fraction the fraction of blood ejected from the heart into the arteries, normally this ranges from 60 to 75%; a low ejection fraction is less than 40%; often used as a marker of left ventricular contractility.

heart failure failure of the heart to pump sufficient blood from the chambers into the aorta; inadequate supply of blood reaches organs and tissues.

left ventricular dysfunction poor contractility of the left ventricle, this leads to heart failure.

IT IS WELL-ESTABLISHED THAT CARDIOVASCULAR morbidity and mortality caused by hypertension, heart failure, and coronary artery disease are substantially higher in African-Americans than in Caucasian Americans, and a plethora of explanations have been put forth. African-Americans are three times as likely to die from cardiovascular diseases than Caucasians, and the Association of Black Cardiologists was formed in 1974 to bring special attention to this issue.

I. HYPERTENSION

A. Epidemiology

Nearly one in three African-Americans suffer from hypertension. In 1995 the death rate was 355% higher in African-American males and 352% higher in African-American females than in white males and females, respectively. The prevalence of stage 3 hypertension (>180/110 mmHg) is approximately 8% in African-Americans versus less than 1% in whites. The prevalence of hypertension is 33 and 50% greater in African-American

men and women, respectively, compared with gender-matched whites.

An important issue that remains unclear is the finding that hypertension and its adverse clinical sequelae — heart failure, stroke, and renal damage — are more common among African-American residents of the 13 southeastern states than among African-Americans residing in other areas of the United States. This appears to be the result of a higher level of psychological stress related to racism, deprivation, and despair that occurs in those southeastern states. Also, there is a higher number of obese African-Americans in these states compared to elsewhere, and their levels of physical activity are considerably lower. African-Americans who have realized financial stability engage in more physical activity than those who live in an environment of poverty.

B. Target Organ Damage

Many investigators have noted a greater susceptibility to target organ damage (heart, kidney, brain) at a given blood pressure level in African-Americans compared with whites. The pathogenesis of the premature blood pressure elevations and early target organ damage in African-Americans has not been clarified.

Hypertension-related left ventricular hypertrophy, left ventricular strain, and heart failure are more common in African-Americans than in whites, at lower levels of blood pressure and at a timing that often appears to be of surprisingly short duration. There is no doubt that renal damage is a prominent feature of early hypertensive disease in these individuals. There is an excess prevalence and incidence of proteinuria, renal insufficiency, and renal failure in African-Americans. The kidney in African-Americans appears to have increased sensitivity to elevated blood pressure as reflected by the excess prevalence of kidney damage and renal failure across a broad blood pressure range in African-Americans compared to whites with similar blood pressure levels. Among African-Americans stroke mortality rates are 30–50% higher in the southeastern United States than elsewhere, and

coronary artery disease death rates for African-Americans are among the highest in the world.

C. Role of Obesity

Obesity is disproportionately prevalent among female African-Americans, and this is prominent in the southeastern United States. Obesity causes hypertension that is driven by activation of the sympathetic nervous and renin-angiotensin-aldosterone systems and additional plasma volume expansion. Flack and Staffileno postulated a linkage of obesity in African-American women with normal to high normal blood pressure to both salt sensitivity and a reversible attenuation of normal nocturnal decline in blood pressure. This causes a higher nighttime blood pressure and thus a greater 24-h blood pressure burden that probably contributes to obesity-related target organ damage. In Jamaicans obesity has been associated with increased circulating angiotensinogen and serum angiotensin-converting enzyme activity. Circulating renin levels in obese hypertensives are not usually suppressed, and there is increased renal sodium reabsorption in the distal tubule.

D. Management of Hypertension

Salt sensitivity is more common among the African-American population than in others races, and it can influence the effect of some antihypertensive agents. There is little doubt that salt sensitivity, obesity, and stress are important inducers of sustained hypertension in the African-American population, and management must address these issues.

I. Elderly African-American Patients

Hypertension in the elderly patient of African origin over age 60 responds best to diuretic therapy. These low-cost drugs have been well tested and proven effective in several randomized, controlled trials and are highly recommend as first-line therapy for hypertension by the Joint National Committee and the World Health Organization Society. Several randomized clinical trials have shown calcium antagonists to also be very effective antihypertensive agents in this population. They are used as monotherapy in patients intolerant to diuretics and in selected individuals they are combined with a diuretic. Caution is required, however, in patients with an ejection fraction less than 40%, because the risk of heart failure may increase with long-term calcium antagonist therapy. The addition of an

ACE inhibitor may be required in diabetics and in patients with left ventricular dysfunction.

2. Younger African-American Patients

Younger individuals of African origin less than age 60 gain the best antihypertensive effects with calcium antagonists or beta-adrenergic blocking agents. The latter may be tried first because these agents are safe, inexpensive, and useful in patients with diabetes and those at high risk for coronary artery disease events. In many patients the combination of a calcium antagonist and a beta-blocking drug (both at low doses) is usually effective in controlling hypertension.

II. HEART FAILURE

African-Americans are 1.5 times more likely to die of heart failure than Caucasians, and men younger than age 60 are twice as likely as Caucasian men of that age to be hospitalized for failure. African-American women are three times as likely as Caucasian women of similar age to be hospitalized because of heart failure.

Small et al. showed that the alpha-2c Del322–325 and beta-1 Arg389 receptors act synergistically to increase the risk of heart failure in blacks. They identified genetic variants of the beta-1 adrenergic receptor and the alpha-2c adrenergic receptor which jointly represent a major risk factor for the development of heart failure in blacks subjects. Norepinephrine released from cardiac sympathetic nerves activates myocyte beta-1 adrenergic receptors, which couple to stimulate the G protein Gs, activate adenylyl cyclase, and increase intracellular cAMP thereby enhancing beta-1 adrenergic receptor activity and increasing the risk for the development of heart failure.

A. Management

The management of heart failure in African-Americans does not differ significantly from the therapeutic strategies used for treating other population groups. Weight reduction, a graduated exercise program, and a restricted salt diet are essential. In addition, the avoidance of precipitating factors such as the use of selective and nonselective nonsteroidal anti-inflammatory agents and other drugs that depress left ventricular contractility is crucial.

Class III and IV heart failure should be treated with the combination of a diuretic (furosemide 40–80 mg daily), an ACE inhibitor, a small titrated dose of a beta-blocker

(carvedilol is strongly recommended), spironolactone or eplerenone, and digoxin. Class II heart failure should be managed with a diuretic, an ACE inhibitor, and carvedilol or metoprolol. Class I heart failure requires cardioprotection with an ACE inhibitor, a beta-blocker, and a variable small dose of a diuretic for the prevention of shortness of breath.

I. Diuretic

A diuretic is very effective for the relief of shortness of breath. Furosemide, 40–120 mg daily, is frequently required. Salt sensitivity is a common feature of hypertension and heart failure in this population group. If hypertension is not controlled with an ACE inhibitor and beta-blocker, then hydrochlorothiazide 25 g once daily can be added to furosemide 40 mg daily. Serum potassium should be carefully watched so that it does not fall to less than 4 mEq/L. Magnesium depletion should be corrected and the dose of diuretics should be reduced if uric acid levels are increased.

2. ACE Inhibitor

The effectiveness of ACE inhibitors in the management of heart failure in this population group remains controversial. An underrepresentation of patients of African origin in trials of therapy for heart failure is a major impediment to the analysis of racial differences in therapeutic response.

a. Clinical Trials

The only reference trial is a retrospective analysis of the studies of left ventricular dysfunction (SOLVD). This well-run, large placebo-controlled randomized clinical trial involved 5719 white patients with only 800 black patients. The trial, published in 1991, yielded conclusive evidence that in white patients enalapril caused a 35% reduction in mortality rate in patients with heart failure and an ejection fraction less than 35%. Enalapril significantly reduced the number of hospitalizations for heart failure. Because greater than 65% of patients in this trial were more than 4 weeks post myocardial infarction, the study cannot be generalized to all patients with heart failure. It appeared that the few black patients enrolled in the trial did not obtain significant benefit, but their representation was small and the stigma that blacks do not benefit from ACE inhibitor therapy was propagated.

Recently a pooled analysis of the SOLVD study was made by Exner et al. to address this controversy.

Study question: Black patients with heart failure have a poorer prognosis than white patients, and the difference has not been adequately explained. To address this issue Exner et al. pooled and analyzed data from the SOLVD prevention and treatment trials — two large, randomized trials comparing the ACE inhibitor enalapril with placebo in patients with left ventricular dysfunction.

Methods: A mixed cohort design was used where up to four white patients were matched with each black patient according to trial treatment assignment. A total of 1196 white patients (580 from the prevention trial and 616 from the treatment trial) were matched with 800 black patients (404 from the prevention trial and 396 from the treatment trial). Follow up was 35 months in the prevention trial and 33 months in the treatment trial.

Results: Black patients had higher rates of hospitalization for heart failure (13.2 vs. 7.7 per 100 person-years). Enalapril, as compared with placebo, was associated with a 44% reduction in the risk of hospitalization for heart failure among the white patients ($p < 0.001$) but with no significant reduction among black patients ($p = 0.14$). Exner et al. concluded that this finding underscores the need for additional research on the efficacy of therapies for heart failure in black patients.

The methodology of this trial analysis leaves much to be desired and the results should be disregarded.

Dries et al. reanalyzed the effect of enalapril in the black patients assigned to the treatment arm of the SOLVD trial (a post hoc analysis of the 3651 white and 403 black patients). In this trial enalapril was administered to 195 black patients and placebo to 208 and followed for 33 months.

Randomization to enalapril was associated with a comparable reduction in the relative risk of the development of symptomatic heart failure in black and white patients. Treatment with enalapril was associated with a comparable reduction in the risk of developing heart failure in both black and white patients. Enalapril was equally efficacious in reducing the risk of progression of asymptomatic left ventricular dysfunction in these two ethnic groups. This study has several important limitations: it was retrospective and the number of black patients in the study was small. The results of this ad hoc analysis, however, support the recommendation that therapies demonstrated to improve survival in large, randomized trials should continue to be prescribed at appropriate doses for patients with heart failure irrespective of their ethnicity until results of large trials are available.

Omapatrilat is a vasopeptidase inhibitor that has actions similar to ACE inhibitors. A large, randomized clinical study has shown beneficial effects, but the occurrence of angioedema (life-threatening swelling of lips and tongue) was excessively high in black patients.

3. Beta-Blockers

Beta-blockers used in heart failure (carvedilol and metoprolol) are efficacious in both black and white patients. Yancy et al. analyzed the effects of carvedilol in 217 black and 877 non-black patients assigned to the U. S. Carvedilol Heart Failure trial. Patients had heart failure class II, III, or IV and an ejection fraction less than 35%.

Results: As compared with placebo, carvedilol reduced the risk of death from any cause or hospitalization by 48% in black patients and by 30% in non-black patients. The drug reduced the risk of worsening heart failure by 54% in black patients and 51% in non-black patients.

Conclusions: Benefit of carvedilol was of similar magnitude in both black and non-black patients with heart failure.

Racial and ethnic differences in drug responses related to hepatic cytochrome P-450, which is responsible for the metabolism of several drugs including carvedilol, have been described and reflect genetic differences in drug activity.

4. Digoxin

The therapeutic benefits of digoxin are of similar magnitude in both black and non-black patients with heart failure. Lower doses than previously used are now recommended in all population groups, with digoxin blood levels of 0.6–1.2 ng/ml being considered adequate; women should be titrated to the lowest serum levels because mortality may be increased at levels greater than 1.0 ng/ml.

5. Spironolactone or Eplerenone

The well-known mild diuretic spironolactone blocks the effects of aldosterone in the distal renal tubules and enhances the effectiveness of diuretics. This drug also has beneficial cardiac effects that have been shown to prevent recurrence of heart failure. Eplerenone has the same effectiveness as spironolactone, but it does not cause bothersome gynecomastia which limits the use of spironolactone (see the chapter Diuretics).

III. CORONARY ARTERY DISEASE AND STROKE

A. African-Americans

In 1995, death from coronary artery disease was 40% higher in African-Americans than in Caucasians. From ages 35 to 74, the age-adjusted death rate from coronary artery disease in African-American women is more than 71% higher than that of Caucasian women. Coronary artery disease death rates for African-Americans are among the highest in the world. High rates of smoking, unnoticed increased LDL cholesterol, and the high prevalence of obesity, diabetes, and stress all play a role in increasing coronary-related mortality in African-Americans. Young African-Americans have a 2- to 3-fold greater risk of suffering a stroke and a 1.8-fold greater mortality rate for stroke than Caucasians.

B. Heart Disease in Asian Indians

High prevalence rates of premature coronary artery disease have been reported in migrant Asian Indians. A comparison of migrant Indians living in West London with native Indians living in Punjab indicated that the migrant Indians had a higher body mass index, higher systolic blood pressure, and significantly higher lipid levels. Both the migrant and native Indians, however, had elevated lipoprotein(a) levels, suggesting that genetic influences may predispose Indians to premature coronary disease.

The prevalence of coronary artery disease is rising rapidly in urban India. The overall figure of an 11% rate of coronary artery disease in the population represents approximately a tenfold increase in the prevalence of coronary artery disease in urban India during the last 40 years. This is expected to increase substantially over the next 20 years.

I. Clinical Study: Mohan et al.

In a population-based study in Chennai (formerly Madras) involving 1262 individuals older than 20 years, the prevalence rates for coronary artery disease were 9.1, 14.9, and 21.4% in those with normal glucose tolerance, impaired glucose tolerance, or diabetes, respectively. The prevalence of coronary artery disease increased with an increase in total cholesterol with an increased level of low density lipoprotein cholesterol (3.49 ± 0.86 vs. 2.81 ± 0.88 mmol/L). LDL cholesterol was defined as the major risk factor. Although HDL cholesterol levels in this study population were relatively low (1.03 mmol/L; 40 mg/dl),

there was no difference in mean HDL cholesterol levels between the group with coronary artery disease and the group without coronary artery disease. In this small population survey cigarette smoking was low at less than 15% in both groups.

Perspective: It is important to emphasize that the portion of calories derived from fat, much of which comes from dairy products, is significantly higher in India than in other parts of the developing world. Also, the use of ghee and cooking oils derived from coconut, palm, and peanut oil, and other atherogenic oils needs further assessment.

C. Other Ethnic Groups

Death rates from coronary artery disease in men and women are remarkably high in the following countries:

- Finland — 631 and 587 per 100,000 men and women, respectively
- Ukraine — 749 and 342 per 100,000 men and women, respectively, with a cardiovascular disease mortality of 1490 for men and 830 for women
- Russian Federation — 767 and 288 per 100,000 men and women, respectively, with a cardiovascular disease mortality rate of 1343 for men and 657 for women
- Scotland and Northern Ireland — 655 and 273 per 100,000 men and women, respectively, with a cardiovascular disease rate of 886 in men and 441 in women

Death rates are low in France with 142 men and 36 women in 100,000; Spain with 181 men and 52 women in 100,000; and Portugal 207 men and 73 women in 100,000. Cardiovascular disease mortality is surprisingly

low in Slovenia and yet very high in the Ukraine. Both China and Japan have low coronary artery disease death rates but extraordinarily high hemorrhagic stroke rates. The low rates of coronary artery disease and high rates of stroke may be caused by genetic factors, but it has been postulated that the overall low serum cholesterol levels may contribute to high rates of hemorrhagic stroke.

BIBLIOGRAPHY

- Budoff, M. J., Yang, T. P., Shavelle, R. M. et al. Ethnic differences in coronary atherosclerosis. *J. Am. Coll. Cardiol.*, 39:408–12, 2002.
- Dries, D. L., Strong, M. H., Cooper, R. S. et al. Efficacy of angiotensin converting enzyme inhibition in reducing progression from asymptomatic left ventricular dysfunction to symptomatic heart failure in black and white patients. *J. Am. Coll. Cardiol.*, 40:311–7, 2002.
- Exner, D. V., Dries, D. L., Domanski, M. J., and Cohn, J. N. Lesser response to angiotensin converting enzyme inhibitor therapy in black as compared with white patients with left ventricular dysfunction. *N. Engl. J. Med.*, 344:1351–7, 2001.
- Flack, J. M., and Staffileno, B. A. Hypertension in blacks. In *Hypertension, A Companion to Brenner and Rector's The Kidney*. S. Oparil and M. A. Weber, eds. W. B. Saunders, Philadelphia, 558, 2000.
- Mohan, V., Deepa, R., Rani, S. S. et al. Prevalence of coronary artery disease and its relationship to lipids in a selected population in south India. *J. Am. Coll. Cardiol.*, 38:682–7, 2001.
- Parmley, W. W. African American patients and heart disease. *J. Am. Coll. Cardiol.*, 38:Editor's page, 2001.
- Small, K. M., Wagoner, L. E., Levin, A. M. et al. Synergistic polymorphism of beta-1- and alpha 2c-adrenergic receptors and the risk of congestive heart failure. *N. Engl. J. Med.*, 347:1135–42, 2002.
- Wood, A. J. J. Racial differences in the response to drugs — pointers to genetic differences. *N. Engl. J. Med.*, 344:1393–95, 2001.
- Yancy, C. W., Fowler, M. B., Colluccci, W. S. et al. Grace and the response to adrenergic blockade with carvedilol in patients with chronic heart failure. *N. Engl. J. Med.*, 344:1358–65, 2001.

Sleep and the Heart

- I. Effects of Normal Sleep on the Cardiovascular System
- II. Sleep Apneas
- III. Sleep Apnea and Heart Failure
- IV. Sleep Apnea and Hypertension
- V. Sleep Apnea and Arrhythmias

GLOSSARY

apnea cessation of airflow for at least 10 seconds.

arrhythmia general term for an irregularity or rapidity of the heartbeat, an abnormal heart rhythm.

ejection fraction the fraction of blood ejected from the heart into the arteries, normally this ranges from 60 to 75%; a low ejection fraction is a marker of left ventricular contractility.

heart failure failure of the heart to pump sufficient blood from the chambers into the aorta; inadequate supply of blood reaches organs and tissues.

hypopnea abnormal decrease in depth and rate of respiration.

myocardial infarction death of an area of heart muscle due to blockage of a coronary artery by blood clot and atheroma; medical term for heart attack or coronary thrombosis.

IT IS WELL ESTABLISHED THAT SUDDEN CARDIAC death occurs most often within a few hours of waking from sleep. Arousal from sleep causes circulatory, neural, and hormonal alterations that affect the heart and entire circulatory system; the body is instantaneously prepared for the fight or flight reaction. There is increased sympathetic activation, increased secretion of epinephrine (adrenaline), and other processes that result in an increase in heart rate and blood pressure. In addition, catecholamine secretion induces platelet particles in the circulating blood to become sticky resulting in increased platelet aggregation and clot formation. The blockage of the flow of blood by thrombi precipitates acute myocardial infarction and sudden cardiac death. Beta-adrenergic blockers have been shown to reduce the early morning sudden cardiac death rate by more than 35%. Arousal from sleep, therefore, has profound influences on the

cardiovascular system. Recently sleep apnea and the arousal reaction have been shown to play a role in increasing morbidity in patients with heart failure.

It must be emphasized, however, that sleep apneas do not cause heart failure in individuals with normal hearts and normal ventricular function. Sleep apneas are not associated with the epidemic of atherothrombosis, which is the main cause for heart attack and stroke. Also its link with causation of hypertension in the population at large remains controversial and is overexaggerated. Recent studies suggest that sleep apneas are associated with increased cardiovascular morbidity.

I. EFFECTS OF NORMAL SLEEP ON THE CARDIOVASCULAR SYSTEM

Nonrapid eye movement (NREM) sleep comprises more than 85% of total sleep time and is associated with a state of cardiovascular relaxation. There is a reduction in sympathetic nervous system activity, systemic arterial vascular resistance, heart rate, and cardiac stroke volume.

Cardiac output = cardiac stroke volume \times heart rate.

Blood pressure (BP) falls because of the decrease in cardiac output (CO) and reduction in total peripheral resistance (TPR).

$$BP = CO \times TPR.$$

Vagal activity increases thus the heart rate falls further to 40–60 beats per minute.

Rapid eye movement sleep (REM) constitutes approximately 15% of total sleep time and intermittent surges in sympathetic discharge, heart rate, and blood pressure may occur, but the average blood pressure and heart rate generally remain below waking levels.

II. SLEEP APNEAS

Obstructive sleep apnea (OSA) and central sleep apnea (CSA) are the two major recognized forms of sleep apnea.

Obstructive sleep apneas and hypopneas are caused by complete or partial collapse of an *abnormally* narrowed pharynx. In these individuals the effort required to enhance airflow increases causing the rib cage and abdomen to distort and move out of phase; thus, there is prominent respiratory effort. Central sleep apnea is caused by reductions in the central respiratory drive manifested by an absence of respiratory effort.

A. Obstructive Sleep Apnea

Sleep apnea is defined as repetitive episodes of decreased or total cessation of respiratory airflow during sleep, leading to a fall in oxygen saturation of $\geq 4\%$ and sleep fragmentation.

The severity of OSA is measured as the apnea-hypopnea index (AHI). Approximately 20% of men and 10% of women in the North American population have an AHI greater than five events per hour of sleep. By definition excessive daytime sleepiness must be present to be diagnostic for significant sleep apnea. Using this definition only 4% of middle-aged men and 2% of women in North America manifest symptoms of OSA and an AHI of greater than five events per hour of sleep. The diagnosis of sleep apnea is generally based on the demonstration of at least 10–15 apneas and hypopneas per hour of sleep. This diagnosis is confirmed by the presence of excessive daytime sleepiness. Using this diagnostic claim less than 2% of the population is expected to have significant sleep apnea. Other symptoms include excessive snoring, restless sleep, morning headaches, and fatigue, but these symptoms are nonspecific.

More than 96% of individuals that comprise the North American population have normal pharyngeal anatomy and sufficient partial withdrawal of pharyngeal dilator muscle tone. This associated with pharyngeal collapse during sleep. It is not surprising, therefore, that less than 2% of individuals without heart failure have significant OSA, a condition that is greatly exaggerated and exploited.

Approximately 2% of North Americans have an anatomically narrowed pharynx and superimposition of the normal withdrawal of pharyngeal dilator muscle tone during sleep, which causes the pharynx to constrict markedly restricting airflow and precipitating apnea.

I. Mechanisms underlying the hypertensive effects of OSA

These are multifactorial:

- Nocturnal chemoreflex activation by hypoxia and hypercapnia, with consequent sympathetic activation causes transient increase in blood pressure (see Figure 1).

- It has been postulated that the above effect might carry over into excessive sympathetic activity and higher blood pressure during daytime.
- Chemoreceptor resetting and tonic chemoreceptor activation may probably contribute to daytime increases in sympathetic activity and blood pressure.

2. Risk Factors for OSA

Obesity is a major risk factor of OSA. Obesity is present in approximately 70% of patients. It is the only major reversible risk factor. The underlying mechanisms are unclear, however. Pharyngeal airway size is probably diminished with increased weight thus increasing the propensity for obstructive apnea. It has been suggested that layering of fat adjacent to the pharynx narrows its lumen in obese patients.

Alcohol consumption suppresses pharyngeal dilator muscle activation and may predispose individuals to obstructive apnea, but these effects need further clarification and observation.

B. Central Sleep Apnea

Central sleep apnea that arises as a consequence of heart failure is known by physicians as Cheyne-Stokes respiration. It is a manifestation of severe heart failure, New York Heart Association class IV. It is well recognized that patients who manifest Cheyne-Stokes respiration have a poor prognosis and require aggressive medical therapy. Cheyne-Stokes respiration is a form of periodic breathing during which CSAs and hypopneas alternate with periods of hyperventilation that have a waxing and waning pattern of tidal volume. In CSA, arousals are not required for the initiation of airflow, but arousals frequently follow the resumption of breathing.

Sleep is fragmented by frequent arousals but only a few patients complain of habitual snoring or excessive daytime sleepiness. The administration of supplemental oxygen at night has been shown to abolish apnea-related hypoxia, but oxygen has not been shown to cause improvement in cardiac function or quality of life over a one-month period.

III. SLEEP APNEA AND HEART FAILURE

Obstructive sleep apnea has been observed in 11% of patients with heart failure. The incidence of OSA in patients with heart failure ranges from 11 to 37% as shown in data from small studies. Most important, Javaheri et al.

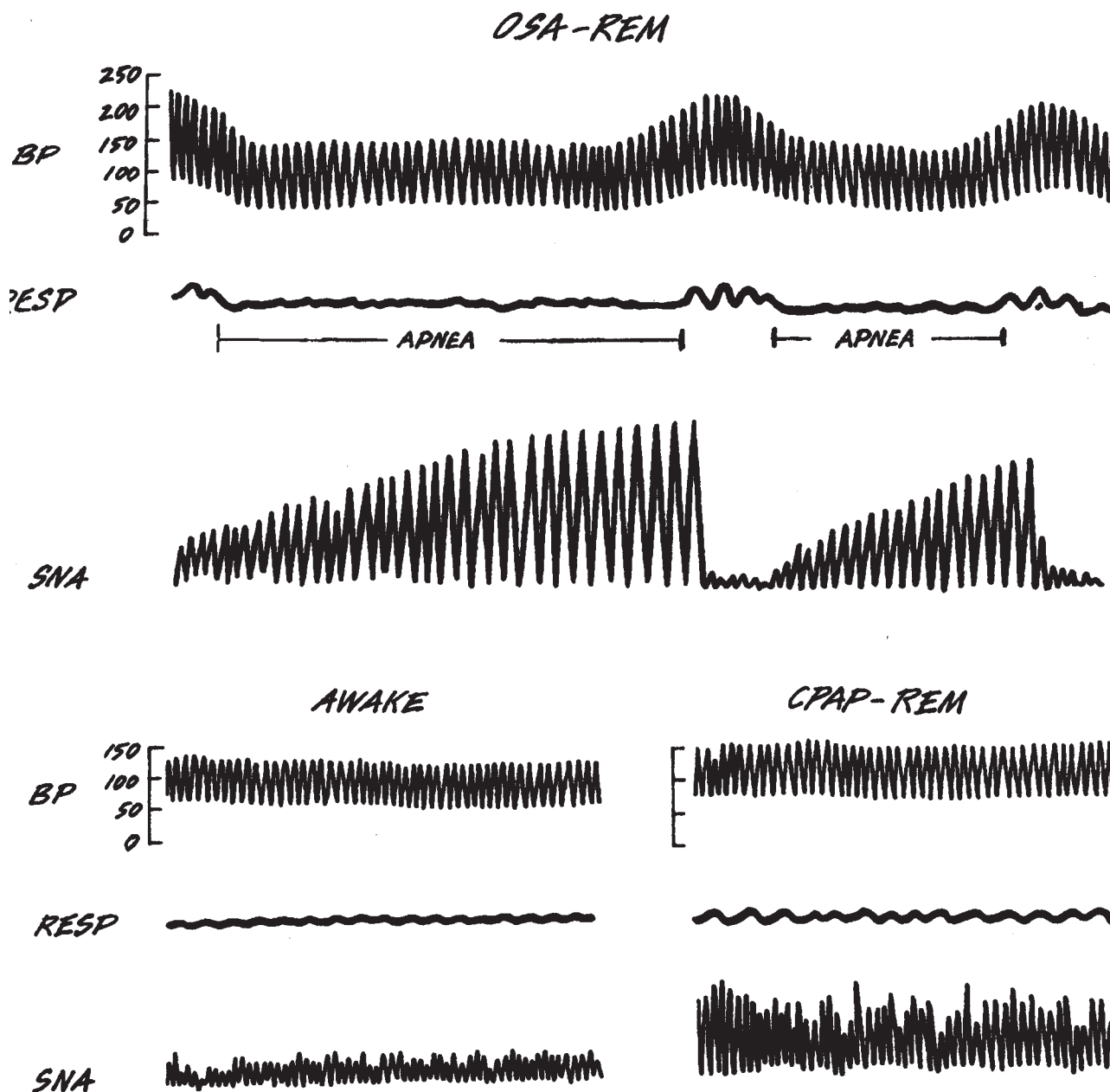

FIGURE 1 Sympathetic nerve activity increases through the obstructive apnea, resulting in marked vasoconstriction followed by increased systolic and diastolic blood pressure. Continuous positive airway pressure (CPAP) stabilizes both sympathetic activity and blood pressure surges. BP = blood pressure (mm Hg); OSA = obstructive sleep apnea; REM = rapid eye movement; RESP = respiration; SNA = sympathetic nerve activation. (Adapted from V.K., Dyken, M.E. et al., *J. Clin. Invest.*, 96, 1897-1904, 1995. With permission.)

noted that only a minority of patients in these studies complained of excessive daytime sleepiness, which suggests that many patients with heart failure have relatively asymptomatic OSA. The mechanism by which heart failure increases the propensity to precipitate OSA remains unclear, and its effects on morbidity and mortality in patients with heart failure require further studies.

A randomized trial was done of patients with relatively severe OSA with an AHI of greater than 30 events per hour of sleep that resulted in symptoms of excessive daytime sleepiness. This study showed that although patients randomized to CPAP (continuous positive airway pressure) were compliant, they did not derive any symptomatic or neurocognitive benefit. These findings do not support

the use of CPAP for patients with OSA who have no complaint of excessive or inappropriate daytime sleepiness.

I. Clinical Study: Kaneko et al.

Methods: In this study 24 patients with a reduced left ventricular ejection fraction (EF) of less than 45% and obstructive sleep apnea on optimal medical therapy for failure underwent sleep study. On the following morning BP and heart rate were measured and left ventricular dimensions and left ventricular EF were assessed by echocardiography. Individuals were then randomly assigned to receive medical therapy either with (12 patients) or without the addition of CPAP (12 patients) for one month.

Results: In patients receiving medical therapy alone there were no significant changes in daytime BP, heart rate, left ventricular systolic dimension, or EF. In the treated group CPAP markedly reduced OSA, reduced daytime BP and heart rate and, most important, reduced left ventricular and systolic dimension from 54.5 ± 1.8 to 51.7 ± 1.2 mm, and protein foam 25.0 ± 2.8 to $33.8 \pm 2.4\%$ ($p = 0.001$).

Conclusions: OSA appears to have an adverse effect on heart failure that can be ameliorated by CPAP.

Patients in the study were obese, with a body mass index of 31. Only 67 and approximately 50% of patients were receiving digoxin and a beta-blocker, respectively. Patients had New York Heart Association class II or III heart failure and did not have bothersome daytime sleepiness.

The mechanisms contributing to the improvement in left ventricular ejection fraction were probably abolition of psychic surges in left ventricular wall tension during sleep and chronic downward resetting of sympathetic outflow and peripheral resistance secondary to the complete correction of obstructive apnea. The observation that CPAP used only at night causes improvement in EF that persisted in the daytime is an important observation. Nocturnal CPAP does not induce beneficial results in patients with heart failure without sleep apnea. These observations suggest that obstructive apnea has specific detrimental effects on left ventricular function that is partially reversible.

Perspective: Large, randomized clinical trials in patients with heart failure on optimal therapy (>90%) should be on quadruple therapy: ACE inhibitor, diuretic, digoxin, beta-blocker, and spironolactone are required to evaluate the impact of treating OSA and to assess cardiovascular outcomes. It is known that the abolition of hypoxia caused by OSA reduces nocturnal blood pressure and heart rate. Correction of OSA in patients with class IV heart failure awaiting transplantation may be an important therapeutic strategy.

CPAP maintains a patent airway during sleep by splinting the airway with positive pressure applied through a nasal mask. It also significantly corrects obstructive apnea and sleep fragmentation with amelioration of unwanted hemodynamic changes. Although it is successful, compliance remains a major problem and it is expensive. Nasal congestion, dryness, abrasion, and mask leak may be bothersome and intensive education programs are required.

In a randomized trials of three months' duration, application of CPAP increased left ventricular EF. Sin et al. conducted a randomized trial of 29 patients with CSA and heart failure managed with CPAP. This showed a significant reduction in the combined rate of mortality and cardiac transplantation during a five-year period. The Canadian CPAP trial for patients with congestive heart failure and CSA (CANPAP) is in progress.

A. Atrial Pacing in Sleep Apnea

I. Study: Garrigue et al.

Methods: Fifteen patients with central or obstructive sleep apnea who had received a permanent atrial synchronous ventricular pacemaker for bradycardia were studied. All patients underwent a sleep study on consecutive nights: the first night for baseline, one night in spontaneous rhythm, and one in dual-chamber pacing mode with atrial overdrive with a basic rate 15 beats per minute faster than the mean nocturnal sinus rate.

Results: The hypopnea index was reduced from 9 in patients with spontaneous rhythm to 3 with atrial overdrive pacing ($p=0.001$). For both apnea and hypopnea the value for the index was 28 in spontaneous rhythm versus 11 with atrial overdrive pacing ($p=0.001$).

Conclusions: In patients with sleep apnea, atrial overdrive pacing significantly reduced the number of episodes of central or obstructive sleep apnea. Reducing the variations in heart rate markedly reduced the number of episodes of sleep apnea.

Perspective: Whether similar benefits could be achieved with atrial pacing in patients who have no indication for pacemaker implantation remains to be determined. Central and obstructive apnea showed similar improvement with atrial pacing. It is surprising that of the 15 patients in the study with no evidence of heart failure and EFs ranging from 40–56%, 8 showed manifestations of central apnea. This condition is usually seen with severe heart failure, New York Heart Association class IV, with an EF of less than 30%.

IV. SLEEP APNEA AND HYPERTENSION

Since the mid-1980s there has been considerable controversy regarding the relationship between OSA and hypertension. Small studies and some population surveys support the notion that either condition may cause the other, but obesity may cause both hypertension and sleep apnea. More important, more than 80% of symptomatic patients with sleep apnea appear to be at least 20% overweight. Some population surveys have shown minimal or no effect of sleep apnea on blood pressure. Although blood pressure decreases with CPAP administration, the blood pressure reductions observed are modest and inconsistent. There is a suggestion that obstructive sleep apnea can increase daytime hypertension, but a clear association has not yet been established.

After the commencement of apnea, blood pressure declines transiently. After arousal and the resumption of ventilation blood pressure increases significantly for 10–15 seconds and returns to baseline levels in about 45 seconds. An increase of systolic pressure from 20–50 mmHg above awake pressures has been observed in small studies. There is evidence that patients with OSA have increased sympathetic activity but despite a great deal of research, the mechanism of sympathetic activation has not been clarified. Sympathetic activation causes peripheral arteriolar vasoconstriction that increases blood pressure (see Figure 1). Some studies indicate that the brief arousals at the end of apneic episodes stimulate sympathetic activation. Also, stimulation of carotid and aortic chemoreceptors by hypoxemia activates mainstem cardiovascular centers and increases sympathetic traffic. Hypoxemia causes pulmonary arterial hypertension which may cause right ventricular strain.

V. SLEEP APNEA AND ARRHYTHMIAS

A variety of minor, benign arrhythmias may occur during sleep such as atrial and ventricular premature beats, and asymptomatic sinus bradycardia with heart rates of 32–42. Patients may be awakened by short runs of supraventricular tachycardia or paroxysmal atrial fibrillation with a fast heart rate exceeding 150 beats per minute. Heart pauses of 3–6 seconds are often observed during Holter

monitoring, but if there is no sinus node dysfunction a normal rhythm is rapidly restored.

A rare, serious disorder, Brugada syndrome, is a congenital disorder of sodium cardiac channel function characterized by typical ECG changes associated with a high incidence of sudden cardiac death. Some of these episodes of sudden cardiac death occur during sleep. A similar pattern of antiarrhythmic deaths during sleep have been observed in southeastern Asian communities and some regions in Italy. These arrhythmic syndromes may culminate in sudden arrhythmic death often occurring at times of concomitant autonomic arousal and often during sleep. This syndrome has a variety of names: Lai Tai (death during sleep) in Thailand, Bangungut (scream followed by sudden death) in the Philippines, and Pokkuri (unexpected death at night) in Japan (see the chapter Brugada Syndrome).

BIBLIOGRAPHY

- Bradley, T. D., and Floras, J. S. Sleep apnea and heart failure. Part I. Obstructive sleep apnea. *Circulation*, 107:1671–78, 2003.
- Bradley, T. D., and Floras, J. S. Sleep apnea and heart failure. Part II. Central sleep apnea. *Circulation*, 107:1822–26, 2003.
- Garrigue, S., Bordier, P., Jais, P., et al. Benefit of atrial pacing in sleep apnea syndrome. *N. Engl. J. Med.*, 346:404–12, 2002.
- Javaheri, S., Parker, T. J., Liming, J. D. et al. Sleep apnea in 81 ambulatory male patients with stable heart failure: Types and their prevalence, consequences, and presentations. *Circulation*, 97:2154–59, 1998.
- Kaneko, Y., Floras, J. S., Usui, K. et al. Cardiovascular effects of continuous positive airway pressure in patients with heart failure and obstructive sleep apnea. *N. Engl. J. Med.*, 348:1233–41, 2003.
- Lattimore, J.-D. L., Celermajer, D. S., and Wilcox, I. Obstructive sleep apnea and cardiovascular disease. *J. Am. Coll. Cardiol.*, 41:1429–37, 2003.
- Malhotra, A., and White, D. P. Obstructive sleep apnea. *Lancet*, 360:237–45, 2002.
- Marin, J. M., Carrizo, S. J., Vicente, E. et al. Long-term cardiovascular outcomes in men with obstructive sleep apnoea-hypopnoea with or without treatment with continuous positive airway pressure: An observational study. *Lancet*, 365:1046–53, 2005.
- Sin, D. D., Logan, A. G., Fitzgerald, F. S. et al. Effects of continuous positive airway pressure on cardiovascular outcomes in heart failure patients with and without Cheyne-Stokes respiration. *Circulation*, 102: 61–6, 2000.
- Somers, V. K., Dyken, M. E., Clary, M. P., Abboud, F. M. et al. Sympathetic neural mechanisms in obstructive sleep apnea. *J. Clin. Invest.*, 96:1897–1904, 1995.
- Wolk, R., Kara, T., Somers, V. K. et al. Sleep-disordered breathing and cardiovascular disease. *Circulation*, 108:9, 2003.

Stents

- I. A Major Advance
- II. Restenosis
- III. Drug-Eluting Stents
- IV. Problems to be Resolved

GLOSSARY

atheroma same as atherosclerosis, raised plaque filled with cholesterol, calcium, and other substances on the inner wall that obstruct the lumen and the flow of blood; the plaque of atheroma hardens the artery, hence the term atherosclerosis (sclerosis = hardening).

intima the innermost lining of the vessel that is in contact with flowing blood.

smooth muscle cells cells that are predominant in the middle wall of arteries, the media; these cells migrate into the intima to strengthen the wall that is injured during the development of atheroma or following trauma from balloon angioplasty or intracoronary stenting. The strong smooth muscle cells are nature's effective band-aid that help to fortify the damaged wall of arteries.

I. A MAJOR ADVANCE

Coronary stenting is the most important advance in interventional cardiology since the introduction of PTCA by Gruentzig in 1977. Currently the main method of coronary artery revascularization is PTCA, which accounts for more than 1.5 million procedures worldwide annually. Restenosis, however, has remained a perplexing problem, and antiplatelet agents, antioxidants, anticoagulants, calcium antagonists, ACE inhibitors, prednisone, and cholesterol-lowering agents have not reduced its occurrence. The use of intracoronary stents has been shown in several studies to reduce the incidence of angiographic restenosis in patients with discrete, de novo lesions in large target vessels.

Stents provide favorable and predictable acute angiographic results and improve the safety of PTCA by successfully treating acute and threatened occlusions. Stents have been shown to improve long-term clinical outcomes by reducing restenosis, and they decrease the total procedure time for percutaneous coronary intervention (PCI). Stents also provide beneficial results in complex lesion morphologies that have a poor outcome using PTCA; this is particularly observed with total occlusions, ostial stenosis, and eccentric lesions.

The wide acceptance of coronary stenting was based on the results of the landmark Belgian-Netherlands stent (BENESTENT) study and the stent restenosis study (STRESS) trials demonstrating that the elective placement of intracoronary stents significantly reduced the incidence of restenosis in patients with discrete lesions in large target vessels. The exuberant use of stents and their proven beneficial effects have stimulated the introduction of numerous stent designs.

Stents can be classified according to:

- Their mechanism of expansion: self-expanding or balloon expandable
- Their composition: stainless steel, cobalt-based alloy, tantalum, nitinol, inert coating, active coating, or biodegradable
- Their design: mesh structure coil slotted tube, ring, multi-design, or custom design

All stents are available premounted on a delivery system. Colombo et al. emphasized that with the advent of drug-eluting stents many previous recommendations may be altered. Although the technique of stenting may change somewhat, one goal that will not change and will become even more important is the reliable delivery of the stent to the lesion.

II. RESTENOSIS

Intracoronary stenting is still limited, however, by in-stent restenosis. The angiographic restenosis rate in stented

arteries is 20–30% in short lesions and large arteries. Unfortunately, restenosis occurs in 30–50% of patients with diabetes, lengthy lesions, diffuse lesions, and with lesions located at bifurcations. PTCA with stent implantation is associated with restenosis in approximately 20–50% of cases.

The widespread use of stents was initiated in order to reduce the high rate of PTCA restenosis (33%) at 6 months. In the recent hallmark RAVEL study which compared a drug-eluting stent with a standard uncoated stent, the angiographic rate of restenosis at 6 months was 26.6% in the standard stent group in patients with noncomplex coronary lesions. This high rate of in-stent restenosis in noncomplex lesions is clearly unacceptable for standard stenting, and it should not be considered a major advance compared with PTCA for which a second PTCA often confers sustained long-term benefits. Prevention of restenosis following PTCA by some means requires more intensive investigative research and clinical trial testing. The newly developed drug-eluting that have been shown to be superior to standard stents in preventing in-stent restenosis need to be tested in long-term clinical trials in large numbers of patients; they are gaining worldwide acceptance.

Restenosis after stent implantation is caused mainly by neointimal proliferation through the stent struts. At the site of the stent struts a marked activation of inflammatory cells appear to play an important role in the process of neointimal proliferation and restenosis. Prevention or amelioration of this inflammatory response is the target of considerable research. A high plasma level of C-reactive protein (CRP) has been observed following successful stent implantation and appears to predict the risk of restenosis.

The bulk of in-stent restenosis consists of extracellular matrix, proteoglycans, and collagen with less than 12% cells. Deeper penetration of stent struts causes greater neointimal proliferation; this may explain why a larger luminal diameter achieved by PTCA does not necessarily reduce the rate of restenosis. The mechanisms that dictate restenosis following PTCA are different from in-stent restenosis. Overstretching by the balloon catheter causes elastic recoil. Endothelial denudation and exposure of subintimal components cause platelet adherence and aggregation, fibrinogen binding, and thrombus formation into which smooth muscle cells migrate. These cells synthesize matrix and collagen and trigger neointimal hyperplasia. Inflammatory mediators and cells stimulate matrix production and further cellular proliferation is followed by remodeling mediated by adventitial myofibroblasts, and these intricate processes lead to restenosis. Stenting diminishes elastic recoil and negative remodeling, the important mechanical components of restenosis.

III. DRUG-ELUTING STENTS

A drug-eluting stents is a device that releases single or multiple bioactive agents into the circulating blood, which affect tissues adjacent to the stent. The bioactive agents may be simply linked to the stent surface, embedded, and released from within polymer materials or surrounded by and released through a carrier. The carrier may coat or span the stent struts.

A. Sirolimus-Eluting Stents

Sirolimus (rapamycin) is a natural macrocyclic lactone with potent immunosuppressive and antimitotic action which was approved as an antirejection drug in renal transplant recipients. Sirolimus blocks cell cycle progression and expression of inflammatory cytokines, thus, inhibiting cellular proliferation. For this reason, the immunosuppressive properties of sirolimus might inhibit neointimal hyperplasia, so a stent was made and coated with a mixture of synthetic polymers blended with sirolimus. A second layer of drug-free polymers was added to promote gradual release of the drug in a controlled concentration over 30 days.

1. The RAVEL Study

The RAVEL study is a randomized study with the sirolimus-eluting Bx Velocity balloon expandable stent in the treatment of patients with de novo native coronary arteries. The trial randomized 238 patients with single coronary lesions. Patients with complex coronary lesions were excluded. The angiographic rate of restenosis at 6 months was 0% in the drug stent group and 26.6% in the standard stent group. There were no reported cases of subacute thrombosis. Long-term beneficial or adverse effects beyond 2 years are not available and caution is required.

2. The SIRIUS Trial

This trial randomized 1100 patients to treatment with rapamycin-coated stent versus standard stent. Its purpose was to investigate long-term safety in complex coronary lesions. Short-term results indicate a reduction of in-stent (3.2% drug stent vs. 35.4% standard stent) and in-segment restenosis (8.9% vs. 36.3%) with no difference in adverse effects. The high rate of restenosis with standard stents is alarmingly high. Drug-eluting stents will play a major role if their beneficial effects are proven beyond 5 years.

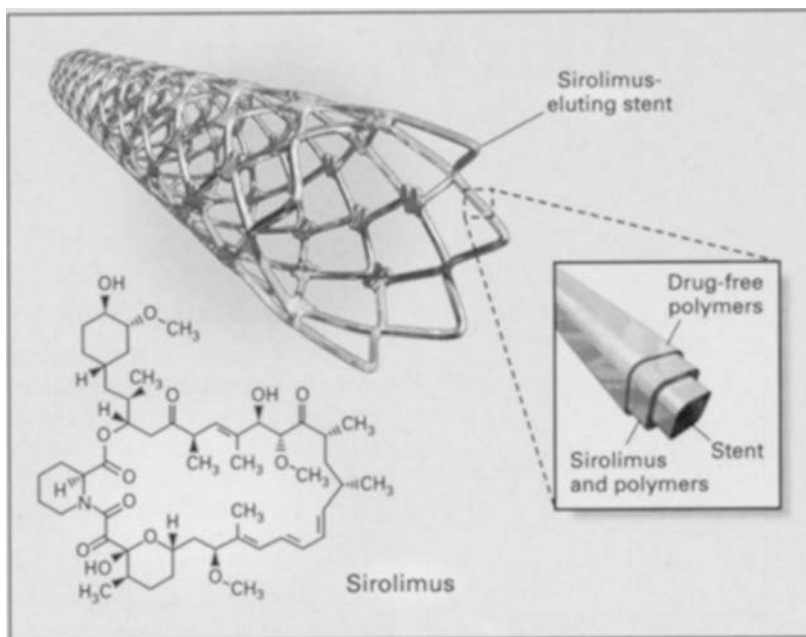

FIGURE 1 The Sirolimus-eluting stent, shown with the chemical structure of the molecule. (From Perspective. (2002). *N. Engl. J. Med.*, 346(23), p. 1770.)

B. Paclitaxel-Eluting Stent

Paclitaxel inhibits cell processes that are dependent on a microtubule turnover, which include mitosis, cell proliferation, and cell migration, but the cells remain viable and in a cytostatic state. Therapeutic concentrations of paclitaxel cause cytostatic inhibition of smooth muscle cells.

The Asian paclitaxel-eluting stent clinical trial (ASPECT) tested the safety and effectiveness of this drug-eluting stent system with the safety and effectiveness of uncoated stents of the same type. This small study of 177 patients followed for 6 months effectively inhibited restenosis and neointimal hyperplasia with the safety profile similar to that of the standard stent. The long-term effects of drug-eluting stents remain unanswered and their role in more complex lesions requires further large clinical studies. Stone et al. studied 1314 patients. The rate of angiographic restenosis at nine months was reduced from 26.6% to 7.9% with the paclitaxel eluting stent.

C. New Agents

Angiopeptin and everolimus are two new agents tested in drug-eluting stents. Angiopeptin, a synthetic cyclic octapeptide analogue of somatostatin, inhibits production of growth hormones including platelet-derived growth factor and epithelial growth factor. This agent inhibits

smooth muscle cell proliferation, but because it is cytostatic it does not appear to cause local toxicity. A phosphorylcholine “sponge” coating loads the drug on to the stent. Tests are being carried out with stents coated with a somatostatin analogue that is human vascular specific.

Everolimus is a new antiproliferative agent that binds to cytosolic immunophyllin and inhibits growth factor driven cell hyperplasia. A bioabsorbable polymer matrix stays on the stent after the drug is gone. This minimizes the inflammatory response but must be degraded and may enhance an unwanted inflammatory response.

IV. PROBLEMS TO BE RESOLVED

A. Long-Term Studies

Polymer coatings have been shown to induce inflammatory responses and fibrinoid deposits. In addition, the stability of polymeric material may degrade over time and delayed intimal hyperplasia may ensue. The perfect carrier for the bioactive material requires substantial search. Biodegradable polymers may prove useful, but the length of drug delivery is a concern. Multilayered polymers for multiple drug release, antigen antibody coating to capture endothelial cells, and other modalities are under investigation.

Long-term drug toxicity must be addressed, because some drug-eluting stent systems including dactinomycin, taxane, and batimast showed delayed thrombosis, delayed restenosis, and aneurysm formation. In case of two stents placed together or overlapping there may be local toxic effects that have not been studied. Beneficial effects in complex coronary lesions must be shown and long-term effects beyond 5 years must be observed and carefully reported.

Some pathologists see trouble ahead for drug-eluting stents. Animal studies indicate that they may merely delay rather than prevent neointimal hyperplasia and restenosis. Six months after stent implantation in animals after most of the drug has been released and the artery has had a chance to heal, neointimal growth has been shown to surge ahead. Late in-stent restenosis is of major concern. In addition, because drug-eluting stents are not fully covered by smooth muscle cells and collagen for the first several months, the likelihood of change position and malposition for drug-eluting stents is approximately five times that of bare metal stents. This movement enhances thrombus formation. Also, biodegradable polymers must be absorbed by the body and may incite a more intense late neointimal inflammatory reaction.

B. Other Drugs to Prevent Restenosis

I. Prednisone: Impress Study

This remarkable study in a small group of 83 patients undergoing successful stenting with CRP levels greater than 0.5 mg/dl 72 h after the procedure were randomized to receive oral prednisone or placebo for 45 days.

Results: The 12-month event-free survival rates were 93 and 65% in patients treated with prednisone and placebo, respectively. The 6-month restenosis rate was lower in the prednisone-treated patients than in the placebo-treated patients (7% vs. 33%; $p = 0.001$).

Conclusions: In patients with persistently high CRP levels after successful coronary artery stent implantation, oral immunosuppressive therapy with prednisone produced a striking reduction of events and angiographic restenosis rate.

Perspective: Although adverse effects were low, corticosteroids have undesirable adverse effects and long-term randomized studies are required to clarify the role of prednisone, other corticosteroids, and immunosuppressive agents in the management of in-stent restenosis.

2. Folate for Restenosis

A study by Lange et al. concluded that contrary to previous findings, the administration of folate, vitamin B₆, and vitamin B₁₂, after coronary stenting, may increase the risk of in-stent restenosis and the need for target-vessel revascularization.

BIBLIOGRAPHY

- Colombo, A., Stankovic, G., and Moses, J. W. Selection of coronary stents. *J. Am. Coll. Cardiol.*, 40:1021–33, 2002.
- Fajadet, J., Morice, M. C., Bode, C. et al. Maintenance of long-term clinical benefit with sirolimus-eluting coronary stents: Three-year results of the RAVEL trial. *Circulation*, 111:1040–1044, 2005.
- Fattori, R., and Piva, T. Drug eluting stents in vascular intervention. *Lancet*, 361:247–49, 2003.
- Goy, J. J., Stauffer, J. C., Siegenthaler, M. et al. A prospective randomized comparison between paclitaxel and sirolimus stents in the real world of interventional cardiology: The TAXi trial. *J. Am. Coll. Cardiol.*, 45:308–311, 2004.
- Lange, H., Suryapranata, H., and De Luca, G. Folate therapy and in-stent restenosis after coronary stenting. 350:2673–2681, 2004.
- Leopold, J. A., Antman, E. M. et al. Dual antiplatelet therapy for coronary stenting: A clear path for a research agenda. *Circulation*, 111:1097–1099, 2005.
- Moliterno, D. J., Healing achilles—sirolimus versus paclitaxel. *N. Engl. J. Med.*, 353:724–727, 2005.
- Morice, M. C., Serruys, P. W., Sousa, J. E. et al. For the RAVEL study group. A randomized comparison of a sirolimus eluting stent with a standard stent for coronary revascularization. *N. Engl. J. Med.*, 346:1773–80, 2002.
- Muni, N. I., Gross, T. P. et al. Problems with drug-eluting coronary stents—The FDA perspective. *N. Engl. J. Med.*, 351:1593–1595, 2004.
- Park, S.-J., Shim, W. H., Ho, D. S. et al. A paclitaxel-eluting stent for the prevention of coronary's restenosis. *N. Engl. J. Med.*, 348:1557–45, 2003.
- Serruys, P. W., Ormiston, J. A., Sianos, G. et al. Actinomycin-eluting stent for coronary revascularization: A randomized feasibility and safety study: The ACTION trial. *J. Am. Coll. Cardiol.*, 44:1363–1367, 2004.
- Stone, G. W., Ellis, S. G., Cox, D. A. et al. A polymer-based, paclitaxel eluting stent in patients with coronary artery disease. *N. Engl. J. Med.*, 350:221–231, 2004.
- van der Hoeven, B. L., Pires, N. M. M., Warda, H. M. et al. Drug-eluting stents: Results, promises and problems. *Int. J. Cardiol.*, 99:9–17, 2005.
- Versaci, F., Gaspardone, A., Tomai, F. et al. Immunosuppressive therapy for the prevention of restenosis after coronary artery stent implantation (IMPRESS study). *J. Am. Coll. Cardiol.*, 40:1935–42, 2002.
- Windecker, S., Remondino, A., Eberli, F. R., et al. Sirolimus-eluting and paclitaxel-eluting stents for coronary revascularization. *N. Engl. J. Med.*, 353: 653–662, 2005.

Stress and Heart Disease

- I. Effects on the Cardiovascular System
- II. Type A Behavior

GLOSSARY

- angina** chest pain caused by temporary lack of blood to an area of heart muscle cells, usually caused by severe obstruction of the artery supplying blood to the segment of cells.
- atherosclerosis** same as atheroma, raised plaques filled with cholesterol, calcium, and other substances on the inner wall of arteries that obstruct the lumen and the flow of blood; the plaque of atheroma hardens the artery, hence the term atherosclerosis (sclerosis = hardening).
- myocardial infarction** death of an area of heart muscle due to blockage of a coronary artery by blood clot and atheroma; medical term for heart attack or coronary thrombosis.
- platelets** very small disk-like particles that circulate in the blood alongside red and white blood cells initiating the formation of blood clots; platelets clump and form little plugs called platelet aggregation, thus causing minor bleeding to stop.

STRESS IS NOT REALLY NERVOUS TENSION, SO WE will not dwell on the subject of nervousness and chronic anxiety, the cause of which must be determined and removed. Damaging or unpleasant stress, as Hans Selye states, is “stress with distress and this is always disagreeable.” Although stress can be associated with pleasant situations, it is more often produced by unpleasant stimuli. The word “stress” is derived from the Old French and Middle English words for “distress”; the first syllable was lost over the years.

I. EFFECTS ON THE CARDIOVASCULAR SYSTEM

There is no doubt that stress is awful. With the exception of severe pain and death, severe stress with distress is one of

the most difficult situations we have to face. Stress produces well-known reactions in the body such as an increase in blood pressure which causes small blood particles (platelets) to become sticky. The platelet particles stick together to form clumps or sludge, which can lead to formation of a blood clot in the coronary artery.

Trauma to arteries wreaks havoc like a silent killer. During the stress reaction, the arteries constrict under the influence of adrenaline and noradrenaline (epinephrine and norepinephrine). Consequently both systolic and diastolic blood pressure increase. If the baseline blood pressure is usually 120/80, it can go up to 160/90 or from 145/95 to as high as 210/110. These elevated pressures, lasting only minutes, are injurious to the arteries, and when combined with the effects of excess adrenaline causing platelet sludging in the arteries, the death toll from heart attacks increases.

How does stress cause heart pain (angina) and damage to the heart and arteries? When the coronary arteries are narrowed by plaques of atheroma, chest pain may occur (see the chapter Angina). Chest pain is made worse by exertion such as walking up a hill. Pain at rest may occur, however, if the patient faces sudden emotional upset.

Stress causes adrenaline and noradrenaline release. These stress hormones cause the heart rate and blood pressure to increase, giving the heart more work to do (see Fig. 1). In some patients, adrenaline may cause platelets to clump onto plaques of atheroma, thus causing oxygen lack to that segment of heart muscle. This oxygen lack may or may not produce chest pain.

Moderate stress associated with simple daily activities can decrease the blood supply to the heart muscle in patients with coronary heart disease. In a study of 16 patients who had angina, the moderate stress of mental arithmetic caused oxygen lack to the heart muscle (myocardial ischemia) similar to that produced by exercise (see Fig. 2). In these patients a radioisotope material (rubidium-82) was injected into a vein, and when it reached the heart muscle photographs were taken. The dark areas in Fig. 2 represent the uptake of blood supply to the heart muscle. When the supply of blood is decreased, the area of muscle is poorly supplied with

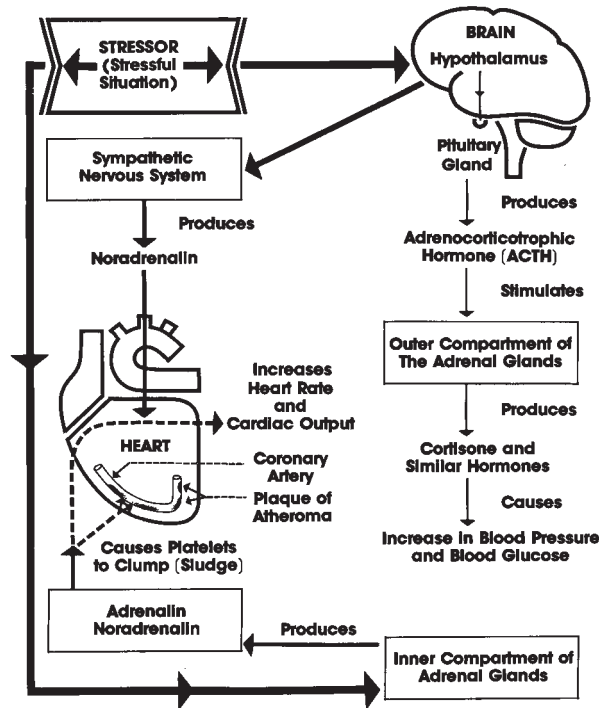

FIGURE 1 Stress and the heart. (From Khan, M. Gabriel and Marriott, H.J.L. (1996). *Heart Trouble Encyclopedia*, Toronto: Stoddart Publishing, p. 248.)

blood, the presence of the rubidium-82 is reduced, and the area of darkness is diminished.

In a similar experiment, a patient who was having catheterization of his heart (coronary arteriogram) was asked to do mental arithmetic, asked to think of a past stressful situation, and saw the result of his catheter studies. His heart muscle function was determined during the test and showed no significant change with thinking of past stress, but showed a mild defect during mental arithmetic and severe defects in muscle function during the explanation and viewing of the findings of his heart catheter test.

A stressful situation causes the “emotional center” in the brain to trigger certain reactions (Fig. 1). The hypothalamus sends signals to the pituitary gland and sympathetic nervous system, which lead to secretion of the “stress hormones” cortisone, adrenaline, and noradrenaline. Cortisone causes an increase in blood glucose and an increase in blood pressure.

As a result of a stressful situation (stressor), the inner compartment of the adrenal glands pours out adrenaline and noradrenaline and these compounds are involved in the “fight or flight” reaction. The external stimulus (stressor) is usually a condition that produces anger, fear, anxiety, and deprivation. Common stressors include the

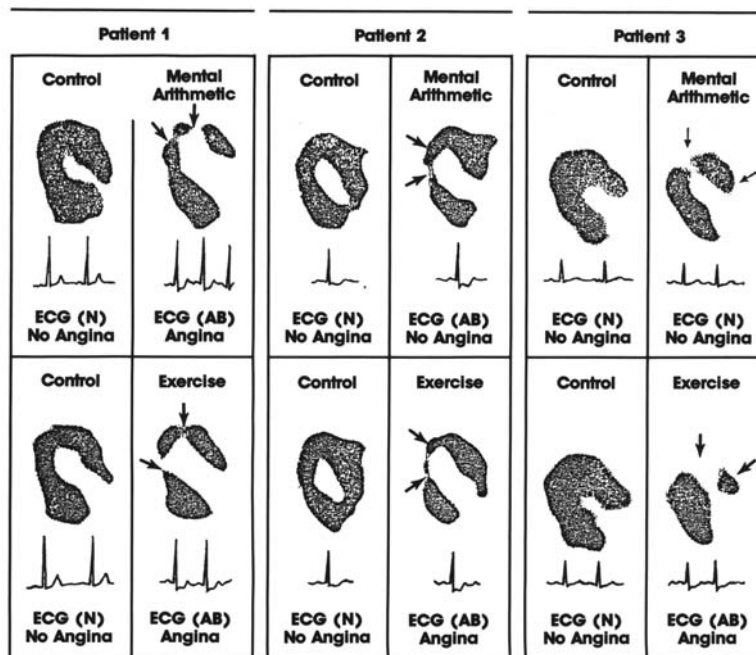

FIGURE 2 The heart under stress. Changes in the uptake of rubidium-82 and the electrocardiogram in relation to chest pain before and after mental arithmetic or exercise. Control scans, dark areas, show normal rubidium-82 uptake by the heart muscle in three patients, indicating normal blood flow. There are defects in uptake (arrows) with mental arithmetic and exercise, and these changes can be accompanied by ECG changes of oxygen lack to the muscle = ischemia = angina. N = normal; AB = abnormal. (Modified from *The Lancet*, 2, 1003, 1984. With permission.)

death of a spouse, conflicts with others, and projects requiring a deadline. Very often the stressor consists of words that are interpreted by the individual as harsh or hurtful, resulting in anger, hostility, humiliation, or resentment.

The body reacts in the same way regardless of the type or source of stress or unexpressed anger. Stress from an argument with the boss, fellow workers, a spouse, or others is the same as stress from being chased by an assailant. The fight for so-called prestige, recognition, and survival at work or at home goes on daily, and for many years you may bear the brunt of the stress.

When an individual is riled to the point of bursting, adrenaline in excess has been poured into the circulating blood. Visualize the adrenaline as little death potions that one may drink at work and for some, unfortunately, at home. Adrenaline is helpful in some situations; for example, when you want to flee from a charging bull or an assailant. These compounds increase the heart rate and blood pressure and increase the supply of blood containing glucose and oxygen to exercising muscles so that you are able to run. An excess of adrenaline and noradrenaline can be dangerous because these chemicals can overstimulate the heart, disturb its electrical stability and, on rare occasions, lead to ventricular fibrillation.

Adrenaline causes a decrease in the ventricular fibrillation threshold and can precipitate ventricular fibrillation and cardiac arrest. Adrenaline causes platelets to clump, and if this occurs on a plaque of atheroma, pain can occur or a clot can develop. These compounds can also cause spasm of the coronary arteries, which in turn can produce chest pain and sometimes death, especially if the spasm occurs where the plaque partially blocks the artery.

Heart deaths are due to two major problems: (1) formation of a blood clot at the site of partial blockage by atherosclerosis in a coronary artery and (2) electrical disturbances that cause the heart to quiver and not contract (ventricular fibrillation). Sudden death is common, and the possibility cannot be excluded that severe acute stress may cause death by initiating a brain-adrenaline-heart interaction (see Fig. 1). The clumping of platelets can enlarge the plaque, and over a period of years the buildup of clot on a plaque can cause complete obstruction of the artery. Animal experiments lend support to this hypothesis. Rats exposed to sudden trauma develop blockage of the coronary arteries, which results in damage to the segments of the heart muscle (myocardial infarction). When rats were not physically traumatized but were stressed with nonphysical traumatic electric shocks, they developed clots in the coronary arteries and died. When rats were pretreated with drugs that prevented platelet clumping, such as aspirin or dipyridamole, and then

subjected to similar electric shocks, clots were prevented in the majority. If rats are pretreated with a beta-blocker, which blocks the dangerous effects of adrenaline, ventricular fibrillation is prevented and rats survive.

Experimentally, adrenaline or noradrenaline given intravenously can cause severe electrical disturbances and ventricular fibrillation. During a heart attack, there is an increase in noradrenaline in the heart muscle. When blood flow to the heart is reduced by atherosclerosis of the coronary artery, severe stress can more easily precipitate ventricular fibrillation.

When a coronary artery is suddenly blocked in dogs, severe quivering of the heart occurs in some. When the hypothalamus (in the brain) and sympathetic nervous systems are stimulated to produce noradrenaline at the same time that the coronary artery is blocked, quivering of the heart frequently occurs. Beta-blocking drugs block the actions of adrenaline and noradrenaline, and if dogs are pretreated with these drugs and the coronary artery is then blocked, the dangerous quivering of the heart can be prevented.

In a study involving 117 patients who were resuscitated from cardiac arrest, 25 reported that they had severe stress such as job and family conflicts within the 24 h prior to the cardiac arrest. Acute or prolonged (chronic) stress may produce severe damage to the coronary arteries. It must be remembered that atheroma of the arteries commonly produces no symptoms; it is a silent killer and after many years, a clot can develop on a ruptured atheromatous plaque. There is considerable evidence linking increased stickiness of platelets to the production of atheroma and blockage of arteries.

A. Stress and Sports

Do not push yourself excessively during a run if you are not a trained athlete. Do it if you feel great and enjoy it, and do not have to clench your jaws or tighten your facial muscles. If you have to push yourself to do an additional mile, then you may secrete excess adrenaline and noradrenaline and this takes its toll on your cardiovascular system throughout the years. Similarly, be careful not to be overly competitive when playing racquet sports.

B. The Symptoms and Signs of Stress

- Sweatiness, especially on the forehead and skull, and under the armpits and on the palms owing to the presence of excess adrenaline.
- Heart races and may easily pound.

- Achiness in the head and neck, especially in the temples or eyes.
- A feeling of turmoil or tightness in the chest or stomach as if there were butterflies in your stomach or there is a feeling of anguish, terror, fright, restlessness, agitation or tremulousness; feeling shaky, jittery, or weak all over.
- Slurred speech with feelings of being unable to scream or talk for a few seconds.
- Hostile, violent, full of rage and anger, and ready to fight back.
- Difficulty sleeping with frequency of urination, indigestion, or sometimes diarrhea.

C. How to Handle Stress

Stress is a part of living and cannot be completely avoided. When you understand how traumatic stress can be to your heart and arteries, you may be motivated to develop techniques to deal with stress. Stress management is a complex subject, beyond the scope of this book. Some of the ways that are indicated to cope with stress include mental diversion, techniques to develop a healthy self-concept, time management, progressive deep relaxation techniques, meditation, biofeedback, and exercise.

D. Conclusion

Stress is as important as the major “risk factors” (cholesterol, hypertension, diabetes, dyslipidemia, cigarette smoking), but it is difficult to prove this hypothesis scientifically. Stress, high blood cholesterol, hypertension, smoking, and blood-clotting factors work in concert in the genetically susceptible individual to produce atherosclerosis and, finally, a fatal or nonfatal heart attack. A stressor causes the sympathetic nervous system and adrenal glands to secrete stress hormones, which increase the work of the heart and cause platelet clumping that can sometimes cause a blood clot in the coronary artery. This chapter has outlined how excess adrenaline and noradrenaline alter the electrical stability of the heart, predisposing it to a high risk of a curious quivering (ventricular fibrillation) during which it fails to contract and sudden death may occur.

Humans are fortunate that the working of the body is such that the reaction caused by one chemical is often counterbalanced by other chemicals that are produced in the body. Nature does not always win, but it can, with a little help from you. It is important to develop strategies that may enable you to deal with various stressful

situations. Thus you will be able to handle stress and subdue the brain-adrenaline-heart-artery reaction described above.

II. TYPE A BEHAVIOR

Type A individuals have an impatient, time-conscious, achievement-striving personality, and they often seek out a hectic environment that provokes undue stress. Leisure brings a feeling of guilt, because their lives are an everlasting struggle against time toward achievement and recognition. The Type A individual takes on a project, including simple reading, with a certain violence. Speech is often harsh, explosive, or aggressive. When stressed, Type A individuals have been shown to release more adrenaline and noradrenaline and to have a greater rise in blood pressure than Type Bs. Type B people are easygoing, able to relax, and rarely carry work home or set deadlines. Most of us are mixtures of Type A and B. It is difficult for a Type A person to change, but with expert assistance, modification of lifestyle is possible.

Friedman and Rosenman have defined and established the concept of the Type A behavior pattern. They emphasized that if you have Type A behavior, you have an increased risk of coronary heart disease. Several studies have confirmed that a relationship exists between Type A behavior and risk of coronary heart disease. This occurs in both men and women independent of high blood cholesterol, hypertension, and smoking. The National Heart Lung Blood Institute has accepted the evidence regarding Type A behavior and increased risk of coronary heart disease.

The question of Type A behavior and increased risk of coronary heart disease remains controversial, however. The large Multiple Risk Factor Intervention Study and a small British study did not show any relationship between Type A behavior and coronary heart disease. A study reported in the *New England Journal of Medicine* found no relationship between Type A behavior and mortality from coronary heart disease in patients who had had a heart attack and were followed for three years. Commencing two weeks after their heart attack, 510 patients were followed. At the end of three years, death rate was not related to behavior, whether Type A or Type B. The mean Type A score did not differ significantly from the score of those who survived. The conclusion is: “Thus, we found no relation between type A behavior and the long-term outcome of acute myocardial infarction.”

BIBLIOGRAPHY

- Case, R. B., Heller, S. S., Case, N. B., and Moss, A. J. Type A behavior and survival after acute myocardial infarction. *312:737-741*, 1985.
- Friedman, M., and Rosenman, R. H. *Type A Behavior and your Heart*. Alfred A. Knopf, New York. 1974.
- Multiple Risk Factor Intervention Trial Research Group. Multiple risk factor intervention trial: Risk factor changes and mortality results. *JAMA*, 248:1465, 1982.
- Yusuf, S., Hawken, S., Öunpuu, S. on behalf of the INTERHEART Study Investigators et al. Effect of potentially modifiable risk factors associated with myocardial infarction in 52 countries (the INTERHEART study): Case-control study. *Lancet*, 364:937-52, 2004.

Stroke/Cerebrovascular Accident

- I. Incidence
- II. Types of Cerebrovascular Accidents
- III. Cerebral Infarction/Ischemic Stroke
- IV. Transient Ischemic Attack
- V. Intracranial Hemorrhage
- VI. Subarachnoid Hemorrhage

GLOSSARY

arrhythmia general term for an irregularity or rapidity of the heartbeat, an abnormal heart rhythm.

atheroma same as atherosclerosis, raised plaques filled with cholesterol, calcium, and other substances on the inner wall of arteries that obstruct the lumen and the flow of blood; the plaque of atheroma hardens the artery, hence the term atherosclerosis (sclerosis = hardening).

atherothrombosis atheroma complicated by rupture or erosion of the plaque with subsequent thrombosis causing complete occlusion of an artery.

embolism, embolus a blood clot that forms in an artery, a vein, or the heart that breaks off and is carried by the circulating blood, finally lodging and blocking the artery that supplies an organ with blood; for example, a pulmonary embolism is an embolus blocking an artery in the lung.

infarction death of cells (necrosis) caused by a marked deficit in blood supply to the area of cells.

ischemia temporary lack of blood and oxygen to an area of cells, for example, the heart muscle, usually due to severe obstruction of the artery supplying blood to this area of cells.

I. INCIDENCE

Cerebrovascular accident, the final outcome of cerebrovascular disease, is the third most common cause of death worldwide after coronary artery disease and cancer combined. It is the most common cause of disability in the world. Annually more than half a million individuals

in the United States have a first cerebrovascular accident. In 1990 cardiovascular disease accounted for more than 14 million deaths in a population of 5.3 billion or 29% of the world's 50 million deaths. Of these, 6.3 million deaths were due to coronary artery disease and 4.4 million were caused by cerebrovascular accident. By 2025 cardiovascular disease will be responsible for an estimated 25 million deaths annually or 36% of all deaths.

The disease causing more than 60% of these cardiovascular deaths is atherothrombosis. The words atheroma and atherothrombosis are hardly known to 99% of the population and they are not a popular research topic for more than 99% of physicians or scientific researchers. This situation is unfortunate and will not change much unless these statistics are publicized and the old word atherosclerosis that connotes hardening of arteries is understood and probably abandoned.

Cardiovascular researchers are interested in left ventricular assist devices (purported to be artificial hearts) that may save the lives of about 4000 individuals worldwide annually at the cost of nearly \$1 million per person. There is also much hype concerning the role of cardiovascular electron beam computerized tomography (EBTC) to detect the calcium content of coronary and other arteries. EBTC is a very expensive test that probably would save no more than one life worldwide annually (see the chapter Tests for Heart Diseases). Emphasis must be placed on extensive funding for research that would uncover the exact cause for atheroma formation which leads to atherothrombotic occlusion of arteries in the heart, brain, and other areas of the body and the prevention of this malignant atheromatous process (see the chapter Atherosclerosis/Atheroma).

II. TYPES OF CEREBROVASCULAR ACCIDENTS

The generic term stroke has become synonymous with cerebrovascular accident and has come to signify the

abrupt impairment of brain function caused by pathologic changes involving intra- or extracranial blood vessels. The cerebral deficit lasts more than 24 hours. If the neurologic impairment lasts less than 24 hours, the condition is then referred to as a transient ischemic attack (TIA).

There are four pathological types of stroke:

1. Cerebral infarction (nonembolic stroke): 40% of all strokes are caused by atherothrombotic disease of the extracranial or less commonly large intracranial arteries; approximately 20% are caused by occlusion of one of the deep perforating cerebral arteries (lacunar infarct).
2. Cerebral infarction caused by emboli mainly from the heart (embolic stroke), ~20%.
3. Intracranial cerebral hemorrhage: hemorrhagic stroke, ~10%.
4. Subarachnoid hemorrhage, ~ 5%.

III. CEREBRAL INFARCTION/ ISCHEMIC STROKE

A. Causation

This most common form of stroke is caused by brain damage (cerebral infarction) that results from obstruction of an artery supplying that area of the brain. Obstruction of the artery is caused by blood clot formation in the artery, often at a point where the artery is narrowed by atheroma/atherosclerosis (see the chapter Atherosclerosis/Atherothrombosis). The term atherothrombosis is now preferred because it brings together the two essential components of the offending obstruction of the artery. This process is identical to that which causes a myocardial infarction and is defined as death of an area of heart muscle due to blockage of a coronary artery by blood clot and atheroma (atherothrombosis). Atherothrombotic ischemic stroke accounts for approximately 55% of all strokes. One risk factor for the development of atherothrombosis and occlusion of arteries is high LDL cholesterol levels of greater than 100 mg/dl (2.5 mmol/L). More than 40% of individuals in the western world, Europe, the UK, Ireland, Russia, and the former Soviet republic countries have an LDL cholesterol greater than 100 mg/dl and are at risk for coronary thrombosis and cerebral thrombosis. Baseline LDL cholesterol levels are on the rise in individuals in developing countries. Diabetes has a major impact on the development of atherothrombosis, and the incidence of diabetes ranges from 6 to 12% in various parts of the world (see the chapter Diabetes).

Hypertension occurs in more than one billion individuals worldwide and increases the risk for the development of atherothrombosis. Cigarette smoking also increases atheroma formation.

Embolic ischemic stroke represents approximately 15% of all strokes. Thrombi originating in the left atrium in patients with atrial fibrillation or located on the left of the ventricular endocardium in patients following acute myocardial infarction may dislodge and be propelled into the circulation (embolize) and end up in a cerebral artery. The occluded artery deprives the brain cells of blood causing an ischemic stroke. In these patients anticoagulation with warfarin is necessary. It has been shown that in these anticoagulated patients, an INR of 1.5–1.9 on hospital admission is associated with a mortality rate similar to that for an INR of less than 1.5. Anticoagulation that results in an INR of 2 or greater reduces not only the frequency of ischemic stroke but also its severity and the risk of death from stroke (see the chapter Atrial Fibrillation).

Other conditions that increase the propensity of the blood to clot or cause damage to arteries and increase the risk of stroke include: antiphospholipid syndrome, thrombocytosis (high platelet levels in circulating blood), protein C and protein S deficiency, factor V Leiden, street drugs, oral contraceptives used in smokers, estrogenic hormone replacement therapy, lupus erythematosus, vasculitis, and hyperhomocystinemia. Fortunately these conditions are rare and are responsible for approximately 5% of all strokes.

B. Symptoms and Signs

If the part of the brain that controls movement of the hand or leg is involved, then loss of strength or complete paralysis of the arm and/or leg occurs. If the speech area of the brain is involved, speech difficulties (dysphasia) become apparent and in some patients, a complete loss of speech (aphasia) occurs.

Clinical manifestations of ischemic stroke include the following:

- Contralateral arm and leg weakness, paralysis (hemiparesis), lower facial weakness on same side as the brain infarct
- Aphasia or dysphasia
- Gait ataxia
- Memory impairment
- Variable degrees of blindness depending on the artery occluded

IV. TRANSIENT ISCHEMIC ATTACK

A. Symptoms and Signs

The symptoms and signs of a TIA depend on the cerebral artery being partially occluded restricting the supply of blood to that part of the brain. There are more than 15 possible arterial sites on each side of the brain and TIAs at each site have their own pattern of symptoms and signs. Some patients have warning attacks of stroke and the various patterns are listed below.

- Numbness with or without weakness of the face, hand, or leg; paralysis
- speech defects (dysphasia or transient aphasia) or slurred speech (dysarthria)
- Transient monocular blindness, double vision, or hemianopia
- Imbalance or incoordination
- Dizziness
- Confusion and headache

Mimics of TIA include a drastic fall in blood pressure on sudden standing from a reclining position (postural hypotension), vasovagal syncope, migraine attack, inner ear disease, transient global amnesia, subdural hematoma, parietal lobe epilepsy, hypoglycemia, polycythemia and other causes of hyperviscosity of blood, cervical disk disease, hypoglycemia, and anxiety.

These symptoms and signs may persist for only minutes, but can last up to 24 h with full recovery and without stroke occurring. Most TIAs resolve within 30 minutes, although some last an hour. Thus if symptoms and abnormal signs last longer than an hour, then severe ischemia is likely to result in death of brain cells called an infarction. The relevant clinical distinction between a TIA and stroke is whether the ischemia has caused brain damage (cerebral infarction) or temporary reversible ischemia that has caused no significant damage to brain cells. The 24-h time frame for disappearance of symptoms is an old concept established in 1965. In the 1975 revision of the National Institutes of Health (NIH) classification document a 24-h limit for TIAs was adopted.

If symptoms and signs last more than an hour, infarction (stroke) often results. Levy has shown that if symptoms last more than 1 hour the likelihood that symptoms will resolve completely within 24 hours is less than 15%. A TIA Working Group in 2002 proposed the following new definition for TIA: It is a brief episode of neurologic dysfunction caused by focal brain or retinal ischemia with clinical symptoms *typically* lasting less than one hour and without evidence of acute infarction.

B. Outcome Following TIA

A study conducted in northern California included 1707 patients with TIA. During a 90-day period after the event about 1 in 9 patients had a stroke, and half of all strokes occurred in the first 2 days. In another study of 198 patients with TIA the risk of stroke was 10%. In patients with atrial fibrillation and embolization of clots to the brain causing TIA the 90-day risk of stroke is approximately 10%.

C. Management

Management involves isolating the cause of the TIA and correcting it. TIAs are commonly due to atheromatous disease of the carotid arteries in the neck as the artery continues deep to the jawbone and enters the brain. Surgery to clean this artery, endarterectomy, is useful in patients with more than 70% obstruction of the carotid artery. A simple test called a carotid Doppler examines the velocity of flow of blood through the carotid artery and gives a reasonable estimate of obstruction: less than 33% percent, nonsignificant; 50–69%, significant; or greater than 75%, severe obstruction. The test is done within minutes as an outpatient and does not require an injection. Before surgery is advised, the result of the Doppler may be confirmed by a dye test called a carotid angiogram.

Doppler ultrasonography has a sensitivity of 83–86% for a stenosis of 70% or greater and should be performed within hours to define the problem.

I. Carotid Endarterectomy

Carotid endarterectomy is beneficial in patients with carotid artery stenosis of 70–99%. MRC asymptomatic carotid surgery trial (ACST) collaborative group carried out the following study.

Method: A total of 3120 asymptomatic patients with substantial carotid narrowing were randomized equally between carotid endarterectomy and in definite the sural of any endarterectomy. Patients were followed for five years.

Results: In patients younger than 75 years of age with carotid stenosis, in >70% immediate carotid endarterectomy halved the net five-year stroke risk from about 12% to about 6% (including the 3% perioperative hazard). Caution is made regarding a skilled surgical team.

In selected patients with carotid lesions amenable for stent placement, beneficial results have been observed by

skilled investigators. The results of the large multicenter randomized CREST trial should answer important questions regarding carotid stenting versus endarterectomy.

Prevention of stroke following a TIA can be partially achieved by slightly thinning the blood with aspirin 75–325 mg daily. Success in patients has been achieved with the use of 325–650 mg aspirin daily, but a dose as low as 75 mg is usually effective. Aspirin prevents blood particles from sticking together to form small friable clots on the artery at the site of atheroma formation. These small friable platelet clots may break off and temporarily block small arteries in the brain causing TIAs, warning attacks, or a small stroke.

Aspirin reduces the long-term risk of stroke following TIA with an overall relative reduction in risk of 22%. Patients who cannot take aspirin because of bleeding from the stomach or gut benefit from the use of clopidogrel or ticlopidine, but the latter agent may cause damage to white blood cells.

Clopidogrel has been shown to be marginally better than aspirin in preventing stroke following stroke or TIA. Ticlopidine has the same beneficial effects but carries the hazard of blood dyscrasias (see the chapter Antiplatelet Agents). The combination of extended-release dipyridamole and aspirin has been shown to be superior to aspirin alone in reducing the risk of stroke among patients following a stroke or TIA and is underused by neurologists and general practitioners.

Aggressive lowering of LDL cholesterol is mandatory for the prevention of fatal and nonfatal strokes. The use of effective cholesterol-lowering drugs such as the statins reduces LDL cholesterol 30–50% and has been shown to decrease atheroma progression. Randomized clinical trials have shown reduction in fatal and nonfatal myocardial infarctions and stroke.

Excellent control of blood pressure helps to prevent strokes but does not eliminate the atheromatous obstruction in the carotid or other arteries and cannot be relied upon to adequately prevent strokes. Hypertension increases atheroma formation but is only one of the many players in the formation and progression of atheromatous obstruction to arteries, which is the root of the problem causing strokes and heart attacks.

V. INTRACRANIAL HEMORRHAGE

Focal cerebral hemorrhages occur spontaneously; some of these are caused by hypertension. Bleeding is believed to result from rupture of a microaneurysm in a small

intracerebral artery. Rarely hemorrhage occurs from ruptured atrioventricular malformations and as a complication of anticoagulant therapy with warfarin or the use of thrombolytic agents for the management of myocardial infarction and stroke.

VI. SUBARACHNOID HEMORRHAGE

Stroke caused by rupture of a small aneurysm of an artery at the base of the brain may rupture and bleed into the subarachnoid space around the brain. These small aneurysms are called berry aneurysms and may be due to a developmental defect on the wall of the artery that stretches, balloons, and forms a small aneurysmal dilatation of the artery. The blood from the ruptured aneurysm may damage the brain substance, and the pressure of the blood clot pressing against the brain leads to a rapid loss of consciousness. This condition is called a subarachnoid hemorrhage (see the chapter Aneurysm).

Considerable brain damage may occur, but urgent surgery to remove the clotted blood that is compressing the brain and to clip the aneurysm is often successful in 75% of the cases. Unfortunately, this type of hemorrhage occurs suddenly in young individuals aged 25–50. A sudden, very severe headache becoming unbearable over minutes to an hour, especially associated with drowsiness or mild confusion, may herald the onset of this type of hemorrhage. Urgent investigation by surgery may prevent disaster. In a few patients, because of recurrent episodes of intense headaches, the diagnosis is made by an angiogram done prior to the rupture of the aneurysm. Clipping the aneurysm is a simple operation because the artery lies outside the brain substance, and it is highly successful. Patients with polycystic kidney disease may have associated berry aneurysms.

BIBLIOGRAPHY

- Hans-Christoph, Bogousslavsky, J., Brass, L. M. on behalf of the MATCH Investigators et al. Aspirin and clopidogrel compared with clopidogrel alone after recent ischaemic stroke or transient ischaemic attack in high-risk patients (MATCH): Randomised, double-blind, placebo-controlled trial. *Lancet*, 364:331–37, 2004.
- Heuschmann, P. U., Kolominsky-Rabas, P. L., Roether, J. for the German Stroke Registers Study Group et al. Predictors of in-hospital mortality in patients with acute ischemic stroke treated with thrombolytic therapy. *JAMA*, 292:1831–1838, 2004.
- Hylek, E. M., Go, A. S., Chang, Y. et al. Effect of intensity of oral anticoagulation on stroke severity and mortality in atrial fibrillation. *N. Engl. J. Med.*, 349:1019–26, 2003.

- Johnston, S. C. Transient ischemic attack. *N. Engl. J. Med.*, 347: 1687–1692, 2002.
- Johnston, S. C., Gress, D. R., Browner, W. S. et al. Short term prognosis after emergency department diagnosis of TIA. *JAMA*, 284:2901–6, 2000.
- Levy, D. E. How transient are transient ischemic attacks? *N. Engl. J. Med.*, 38:674–677, 1988.
- Milionis, H. J., Liberopoulos, E., Goudevenos, J. et al. Risk factors for first-ever acute ischemic non-embolic stroke in elderly individuals. *Int. J. Cardiol.*, 269–275, 2005.
- MRC Asymptomatic Carotid Surgery Trial (ACST) Collaborative Group. *Lancet*, 363:1491–1502, 2004.
- Murray, C. J. L., and Lopez, A. D. *The Global Burden of Disease*. Harvard School of Public Health, Cambridge, MA, 1996.
- The NINDS rt-PA Stroke Study Group. Tissue plasminogen activator for acute ischemic stroke. The National Institute of Neurological Disorders and Stroke rt-PA stroke study group. *N. Engl. J. Med.*, 333:1581–7, 1995.
- The TIA working group. Transient ischemic attack-proposal for a new definition. *N. Engl. J. Med.*, 347:1715–16, 2002.
- Warlow, C., Sudlow, C., Dennis, M. et al. Stroke. *Lancet*, 362: 1211–1124, 2003.
- White, C. J. Another nail in the coffin of carotid endarterectomy. *J. Am. Coll. Cardiol.*, 58:1596–97, 2001.

Syncope

- I. Definition and Incidence
- II. Causes
- III. Diagnostic Evaluation
- IV. Management

GLOSSARY

arrhythmia general term for an irregularity or rapidity of the heartbeat, an abnormal heart rhythm.

atheroma same as atherosclerosis, raised plaques filled with cholesterol, calcium, and other substances on the inner wall of arteries that obstruct the lumen and the flow blood; the plaque of atheroma hardens the artery, hence the term atherosclerosis (sclerosis = hardening).

bradycardia heart rate less than 60 beats a minute.

cardiomyopathy heart muscle disease.

hypotension marked decrease in blood pressure usually less than 95 mmHg.

preload the degree of ventricular muscle stretch present at the onset of myocardial contraction; often expressed as end diastolic volume or pressure.

supraventricular tachycardia tachycardia arising in the atrium, that is above the ventricle.

valvular heart disease pertaining to diseases of the heart and the heart valves.

I. DEFINITION AND INCIDENCE

Syncope is a sudden transient loss of consciousness and postural tone with spontaneous recovery. It is a common medical problem that is often disabling and causes injury; most important, albeit rarely, it may be the only warning sign of sudden cardiac death.

Loss of consciousness during syncope occurs because of a reduction of blood flow to the reticular activating system in the brain stem. Cessation of cerebral blood flow causes loss of consciousness within approximately 10 seconds because the metabolism of the brain is exquisitely

dependent on adequate perfusion. A simple faint and other forms of loss of consciousness lasting a few seconds caused by lack of blood to the brain are medically termed syncope. There are several causes of syncope, which is often difficult to evaluate and investigations to uncover them is expensive. The approximate cost of evaluating and treating patients with syncope in the United States is approximately \$1 billion. Elderly individuals have a 6% annual incidence of syncope and patients with syncope account for approximately 1% of hospital admissions and 3% of emergency room visits.

II. CAUSES

Causes of syncope may be divided into five main groups:

1. Reflex mediated syncope, the simple faint
2. Orthostatic hypotension
3. Cardiovascular disorders (see Table 1)
4. Neurologic disorders
5. Metabolic and miscellaneous disorders

A. Reflex-Mediated Syncope

This is the first and largest category and it consists of a wide variety of disorders associated with sudden transient hypotension and/or bradycardia.

I. Vasovagal Syncope

This is referred to as the simple faint or by some as neurally mediated syncope or neurocardiogenic syncope. The term vaso is indicated by vasodilation and vagal invokes a marked slowing of heart rate. Vasovagal syncope is a common occurrence. Recovery is rapid if the head is kept lower than the legs so that blood can be delivered more efficiently to the brain. Placing the individual flat on the ground with the legs elevated is the quickest method of getting blood to the brain, and afterwards the person rapidly regains consciousness.

TABLE I
Cardiac Causes of Syncope

Tachyarrhythmias	Sustained and nonsustained ventricular tachycardia Torsades de pointes Atrial fibrillation Supraventricular tachycardia Long QT syndrome Wolff-Parkinson-White syndrome Pacemaker mediated
Bradyarrhythmias	Sinus node dysfunction [sick sinus syndrome]
Carotid sinus syncope	
Obstruction to stroke volume	Aortic stenosis Hypertrophic cardiomyopathy Tight mitral stenosis Atrial myxoma or thrombus Cardiac tamponade Prosthetic valve dysfunction Pulmonary embolism Pulmonary hypertension Pulmonary stenosis
Others	Mitral valve prolapse Inferior myocardial infarction Coronary artery spasm Aortic dissection

A good history taken by a physician who is willing to listen and ask probing questions identifies a vasovagal episode and can prevent expensive and time-consuming investigations. A vasovagal episode never occurs with the individual in a recumbent position. A faint is heralded by one or more of the following: a feeling of weakness, lightheadedness, nausea, abdominal discomfort, diaphoresis, dizziness, and blurring of vision. One or more of these symptoms may be present for a few seconds or for a couple of minutes prior to the individual falling to the ground. Often there is sufficient warning to allow the individual to get to a sitting position and to put the head between the knees. Fainting usually occurs in certain settings when the individual may have been standing for too long and blood pools in the legs; less blood then reaches the brain and weakness with transient loss of consciousness may occur.

Some individuals have a propensity to fainting spells. Fainting may be precipitated by drugs that excessively lower blood pressure. Mitral valve prolapse, blood loss, severe vomiting and diarrhea causing dehydration, and high fevers may precipitate attacks. Vasovagal syncope is not associated with abnormal movements of the limbs; such seizure activity may be accompanied by incontinence

or tongue biting, which is not observed with a faint. Vertigo (a rotational sensation) is not a symptom associated with a vasovagal attack.

a. Mechanisms

The combination of vasodepressor and vasovagal (bradycardic) features results in a faint. The vasodepressive component with sudden reduction in blood pressure plays an important role in loss of consciousness. Bradycardia plays a secondary role. Marked vasodilatation (dilation of arteries and arterioles) causes a temporary but profound fall in blood pressure (hypotension). Marked vasodilatation is caused by the inhibition of sympathetic vasoconstrictor activity at the very moment when arteriolar vasoconstriction is necessary to combat the marked fall in blood pressure. The exact reason for this paradoxical reaction of vasodilation instead of vasoconstriction is not well clarified. An increase in cardiac myocardial contractility triggered by mechanoreceptors in the ventricular muscle occurs 2–4 minutes before the onset of syncope occurs in some instances.

b. Triggers

Triggers associated with the development of the simple faint include a decrease in preload causing reduced ventricular filling similar to dehydration; prolonged, motionless standing during hot weather; hot baths or hot showers, or in hot environments, for example, saunas; and fevers causing vasodilation. In these and similar situations pooling of blood occurs in the legs and there is reduced return of blood to the heart. This leads to a reduction in cardiac output and blood pressure in individuals who are already extremely vasodilated because of heat or vasodilator drugs. It is believed that vigorous contraction of the volume-depleted ventricle leads to activation of mechanoreceptors or C fibers that project centrally to the dorsal vagal nucleus in the medulla oblongata of the brain stem. It is believed that this leads to a paradoxical effect that produces a withdrawal of peripheral sympathetic tone causing further vasodilatation instead of beneficial vasoconstriction with bradycardia occurring in some individuals.

Another trigger is sudden increased catecholamine secretion and reflexes mediated by the brain similar to severe pain, fright, sight of blood, stressful situations, and extreme anxiety. The exact mechanisms are not clearly defined. It is clear that not all reflex-mediated syncope results from activation of cardiac mechanoreceptors. Higher centers in the brain participate in the pathophysiology of

this form of simple faint, the vasovagal syncope. It is unclear how a sudden increase in catecholamine secretion precipitates a vasovagal episode.

Individuals with reflex-mediated syncope do not usually hurt themselves during a fall, because there is virtually always a minimal warning that lasts several seconds. When there is virtually no warning and serious injuries occur, this situation is described as malignant vasovagal syndrome.

Syncope occurring during micturition is believed to be caused by activation of mechanoreceptors in the bladder. Syncope that may occur during defecation or swallowing appears to be triggered by gut wall tension receptors and afferent neural impulses arising in the esophagus or stomach, respectively.

2. Carotid Sinus Hypersensitivity

Although carotid sinus hypersensitivity is uncommon in elderly individuals, the precipitation of syncope does occur, though rarely. Thus the diagnosis of syncope due to this disorder should be made only after exclusion of other causes.

B. Orthostatic

Orthostatic hypotension is defined as equal to or greater than a 20 mmHg fall in systolic blood pressure within 3 minutes of standing. On standing, 500–800 ml of blood is displaced to the abdomen and lower extremities, less blood reaches the heart, and cardiac output is reduced. This stimulates baroreceptors in the aortic arch and the carotid artery which cause a reflex increase in sympathetic outflow that increases heart rate, cardiac contractility, and total vascular resistance so blood pressure stabilizes on standing. Table 2 lists causes of orthostatic hypotension and noncardiac causes of syncope.

Drugs are the most common cause of orthostatic hypotension. Several drugs including diuretics that cause volume depletion, decrease preload, and others that cause arterial vasodilatation may precipitate postural hypotension.

C. Cardiovascular

Several cardiac disorders cause syncope or a faint-like feeling (presyncope). Occasionally this is caused by an abnormally slow heart rate of less than 40 beats per minute. This form of disturbance in the electrical conduction of the heart may require the implantation of a pacemaker (see the chapter Pacemakers). Individuals who

TABLE 2
NONCARDIAC^a Causes of Syncope

1. Vasodepressor [vasovagal] or neurocardiogenic causes [>30%]
2. Orthostatic hypotension [10%]
A. Decreased preload
[1] Venous pooling, caused by extensive varicose veins, postexercise vasodilation, venous angioma in the leg
[2] Drugs: nitrates, diuretics, and angiotensin-converting enzyme inhibitors
[3] Decreased blood volume: blood loss
[4] Dehydration: vomiting, diarrhea, excessive sweating, and Addison's disease
B. Drugs
[1] Alpha blockers
[2] Ganglion blockers
[3] Bromocriptine
[4] L-Dopa
[5] Nifedipine
C. Neurogenic decrease of autonomic activity
[1] Bedrest
[2] Neuropathies and diabetes
[3] Shy-Drager syndrome
[4] Idiopathic causes
3. Cerebrovascular disease
A. Transient ischemic attack
B. Subclavian steal
C. Basilar artery migraine
D. Cervical arthritis, atlanto-occipital dislocation, compression of the vertebral artery
4. Situational causes
A. Cough, sneeze, micturition, and defecation
5. Other causes
A. Drugs or alcohol
B. Hypoglycemia
C. Hypoxemia
D. Hypoventilation
E. Hysterical reaction
6. Unexplained

^aNo electrical or structural heart disease.

experience loss of consciousness for a period of seconds or minutes without residual weakness in the limbs and without the precipitating factors mentioned above should consult a physician to check for the possibility of abnormal heart rhythms.

I. Bradyarrhythmias

There are several causes for bradyarrhythmias (slow heart rate). Sinus node dysfunction is one of them. This is a

disease where there is failure of the sinus node pacemaker. Sick sinus syndrome is a common cause of syncope or presyncope, and attacks of syncope may occur with minimal warning, a couple of seconds, or without warning resulting in injuries. A Holter monitor and ambulatory record of the ECG for 24–48 h may reveal heart rates of less than 36 beats per minute or sinus pauses with no heartbeat for 5–10 seconds. A pacemaker is required to manage this problem.

Bradyarrhythmia also occurs with disease of the atrioventricular conducting bundles that carry the electrical current from the AV node to the ventricular muscle. This may be caused by degenerative disease or other disorders, and failure of conduction may result in complete heart block and heart rates of less than 36 beats per minute or no beats for several seconds, which results in loss of consciousness (Stokes-Adams attacks).

The long QT syndrome is an important cause of syncope to be recognized in patients between the age of 5 and 20. Children and young adults with mysterious fainting episodes are often misdiagnosed as having epilepsy or simple fainting that may culminate in sudden death. These syncopal episodes are usually caused by a tachyarrhythmia such as torsades de pointes (form of ventricular tachycardia), which is transient and reverts back to normal rhythm. A family history positive for fainting spells or unexplained sudden death is often present. Episodes may be precipitated by stress, anger, fright, thunder, a siren, a telephone ringing, a clock alarm, and vigorous exertion. This condition is diagnosable only by an ECG, which is a simple inexpensive test that shows prolongation of the QT interval. The use of a continuous loop event recorder may be required.

2. Tachyarrhythmias

Very rapid heart rates (160–230 beats per minute) may be caused by ventricular or supraventricular tachycardia resulting in syncope.

3. Valve Disorders

Tight mitral valve stenosis or a left atrial myxoma (tumor close to the mitral valve orifice) that obstructs the passage of blood from the left atrium to the left ventricle filling may cause syncope, albeit rarely. Patients with mitral valve prolapse occasionally present with syncope.

Obstruction of blood flow from the left ventricle into aorta may be caused by tight aortic valve stenosis or hypertrophic cardiomyopathy. When syncope occurs due to aortic valve stenosis failure to correct the condition by

valve replacement results in a survival of approximately three years from onset of syncope. Syncope occurs in more than 25% of patients with hypertrophic cardiomyopathy (see the chapters *Cardiomyopathy* and *Valve Disease*).

4. Other Disorders

Brugada syndrome is characterized by a typical ECG pattern of right bundle branch block with typical features (see the chapters *Bundle Branch Block* and *Brugada Syndrome*). Arrhythmogenic right ventricular dysplasia is a rare condition that causes syncope and may cause sudden death. The electrocardiographic manifestation is T wave inversion in leads V1 through V3.

Subclavian steal syndrome is an occlusive atheromatous disease of the subclavian artery proximal to the origin of the vertebral artery. It may cause dizziness and syncope. Upper extremity exercise causes blood to be shunted from the brain through the vertebral artery to the distal subclavian artery beyond the blockage. The loss of blood from the cerebral circulation induces symptoms of cerebral ischemia. This syndrome is suggested by the finding of diminished blood pressure in the affected arm, and the induction of symptoms by exercise of the affected arm and forearm also produces symptoms.

III. DIAGNOSTIC EVALUATION

A. Detailed History and Physical Examination

A detailed relevant history of the event taken by an astute physician and a thorough cardiovascular and neurologic examination (if needed) is absolutely necessary. This may reveal the diagnosis of reflex-mediated syncope in more than 95%, orthostatic hypotension in 99%, detection of cardiac abnormalities in more than 90%; and a neurologic disorder in more than 90% of patients. The occasional case of sinus node dysfunction may remain undetected and will require further investigation. With accurate diagnosis, costly investigations may be avoided in more than 85% of patients. An algorithm for the assessment of syncope is given in Fig. 1. Table 3 gives clinical features suggestive of specific causes of syncope.

B. Electrocardiography and Holter Monitoring

In individuals where a cardiac problem is suspected the ECG with a rhythm strip may reveal the diagnosis in 5% and give a presumptive diagnosis in a further 5%. This test is inexpensive and is a necessary initial step. A 24- to 48-h

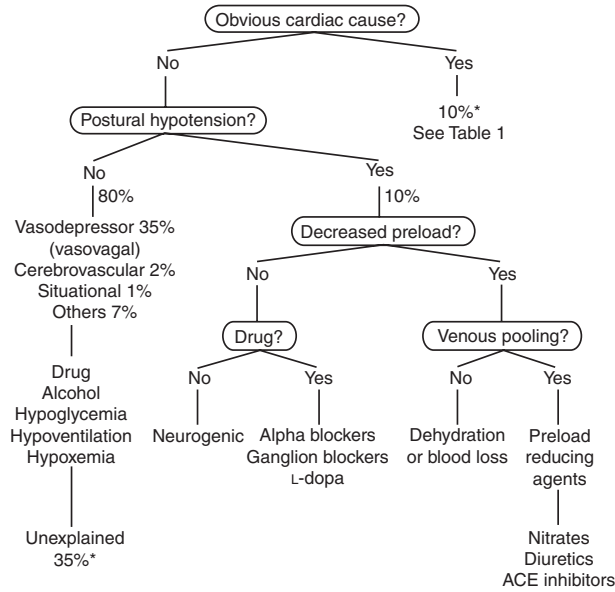

FIGURE 1 Algorithm for the assessment of syncope. *Approximate incidence. ACE = angiotensin-converting enzymes. (Redrawn from Khan, M. Gabriel, *Heart Disease Diagnosis and Therapy: A Practical Approach*, second edition, New Jersey: Humana Press, 2005).

Holter monitoring may help to exclude arrhythmias, but the arrhythmia detected may not be the cause of syncope. Because episodes may only occur once a week or once a month, the recording may be done when the patient is asymptomatic. This test is helpful in patients with sinus node dysfunction, but when the test is negative further investigations are required.

C. Event Recorders

Event recorders are small portable ECG recording devices that can be worn continuously and activated by the patient to record a rhythm strip immediately following an episode. The loop recorder can be activated immediately after the syncopal episode and the ECG recording of the events 2–5 minutes earlier and 30–60 seconds after the episode is taped for interpretation. Approximately 15% of patients with frequent recurrent syncope have arrhythmia detected through loop monitoring.

A continuous loop event recorder carried for extended periods allows both retrospective and prospective ECG recording. It is preferred because other types of event recorders records only when activated by the patient.

Patients with unexplained syncope with injuries that occur only once or twice a year and negative ECG and electrophysiologic (EP) testing present diagnostic problems that may be resolved by an implantable event recorder. This recorder incorporates two electrodes within its container

TABLE 3

Clinical Features Suggestive of Specific Causes

Symptom or finding	Diagnostic consideration
After sudden unexpected pain, unpleasant sight, sound, or smell	Vasovagal syncope
During or immediately after micturition, cough, swallow, or defecation	Situational syncope
With neuralgia (glossopharyngeal or trigeminal)	Bradycardia or vasodepressor reaction
On standing	Orthostatic hypotension
Prolonged standing at attention	Vasovagal syncope
Well-trained athlete after exertion	Neurally mediated
Changing position (from sitting to lying, bending, turning over in bed)	Atrial myxoma, thrombus
Syncope with exertion	Aortic stenosis, pulmonary hypertension, pulmonary embolus, mitral stenosis, idiopathic hypertrophic subaortic stenosis, coronary artery disease, neurally mediated
With head rotation, pressure on carotid sinus (as in tumors, shaving, tight collars)	Carotid sinus syncope
Associated with vertigo, dysarthria, diplopia, and other motor and sensory symptoms of brain stem ischemia	Transient ischemic attack, subclavian steal, basilar artery migraine
With arm exercise	Subclavian steal
Confusion after episode	Seizure

From Kapoor WN: Syncope and hypotension (1997). In Braunwald E (ed): *Heart Disease: A Textbook of Cardiovascular Medicine*. 5th ed. Philadelphia: W.B. Saunders, p. 868.

implanted in the subcutaneous tissue of the chest that can be used for approximately one year.

D. Echocardiography

Echocardiography is a common test, but the yield is poor. It is used to verify severe aortic stenosis, severe mitral stenosis, hypertrophic cardiomyopathy, and left atrial myxoma that cannot be diagnosed by other methods. Careful echocardiographic examination of the right ventricle may reveal features of arrhythmogenic right ventricular dysplasia.

E. Electrophysiologic Testing

EP testing is invasive, expensive, and rarely required. This test is reserved for patients with structural heart disease and syncope that is unexplained after a careful history and physical examination, ECG, echocardiography, Holter monitoring, and continuous loop event recording. EP testing is used mainly to verify the diagnosis of ventricular tachycardia. It may also be helpful in diagnosing sinus node dysfunction in which doubt still exists after other investigations. But it can miss this diagnosis. This test is recommended also for the diagnosis of supraventricular tachycardia, but this disorder is benign and rarely leads to sudden death or injuries and the diagnosis may be established by less expensive investigations. More than 21% of patients with negative EP studies are subsequently diagnosed as having intermittent, high-degree AV block or sinus node dysfunction. An EP study is not a sensitive test meant to expose symptomatic bradycardia.

F. Stress Test

Exercise and echocardiographic stress testing are not useful in patients with ischemic heart disease in the absence of severe angina, because these individuals rarely present with syncope.

G. Tilt-Table Testing

This is a much abused test. It gives diagnostic evidence that indicates susceptibility to neurally mediated syncope, for example, vasovagal syncope (the simple faint). Astute physicians using a carefully taken medical history and physical examination should be able to make the correct diagnosis in more than 95% of cases of vasovagal syncope. Tilt-table testing may help establish the diagnosis of neurally mediated syncope, but false-negative and false-positive results are common. This test may be of some value in patients with unexplained syncope in the absence of structural heart disease and in patients who have sustained injuries.

Tilt-table testing is expensive and nonspecific. This test can also cause harm and its complications include hypotension and minor degrees of cardiac asystole, which can be occasionally prolonged resulting in cerebral damage. Several deaths have also been reported. It is not logical to perform this test to verify the diagnosis of a benign condition that can be diagnosed with a careful history and physical examination. There is a case report of a surgeon who had a syncopal episode while performing surgery and during the tilt test had a stroke.

IV. MANAGEMENT

A. Neurally Mediated Syncope

Precipitating factors for neurally mediated syncope should be identified and eliminated. A moderate increase in salt intake causes improvement. Reconditioning is the cornerstone of therapy in this benign condition. Exercises such as the proper use of the muscle of the legs done daily or standing upright against a wall for 30 minutes daily for 3–4 weeks then 15 minutes 3 days weekly strengthen the autonomic system.

If the condition recurs and the diagnosis is confirmed, drug therapy may be warranted. Beta-blocking agents such as propranolol, metoprolol, or timolol may be tried judiciously at small doses. There is no definitive, well-controlled analysis of the efficacy of beta-blocking agents in patients with recurrent vasovagal syncope.

Two randomized controlled trials studied 50 patients and 30 patients, respectively, and showed that propranolol, metoprolol, and atenolol were no more effective than placebo. Follow up was one year in one study and three months serially for propranolol, nadolol, and placebo in the second study. There are many anecdotal reports and short, nonrandomized trials that claim some benefit.

Fludrocortisone, 0.1–0.2 mg daily, in combination with increased salt intake of greater than 3 g daily in combination with a beta-blocking drug is often effective. Serotonin reuptake inhibitors or midodrine are last resorts. Treatment with drugs is usually targeted to patients where syncope is recurrent without a protective warning and associated with physical injury. A double-blind study showed that pacemaker therapy was no better than placebo for preventing recurrent vasovagal syncope.

B. Orthostatic Syncope

Discontinuation of drugs that cause orthostatic hypotension or volume depletion such as diuretics and vasodilators is necessary. Autonomic neuropathies and autonomic failure may respond to increased sodium intake and fludrocortisone. Autonomic failure causing orthostatic hypotension can be managed in properly selected patients with midodrine, a selective postsynaptic alpha-1 adrenergic agonist. Salutary effects are caused by an increase in arterial and venous tone because venous pooling is prevented.

C. Transient Ischemic Attack

Syncope occurs in approximately 7% of individuals with transient ischemic attacks (TIA). An attack that involves

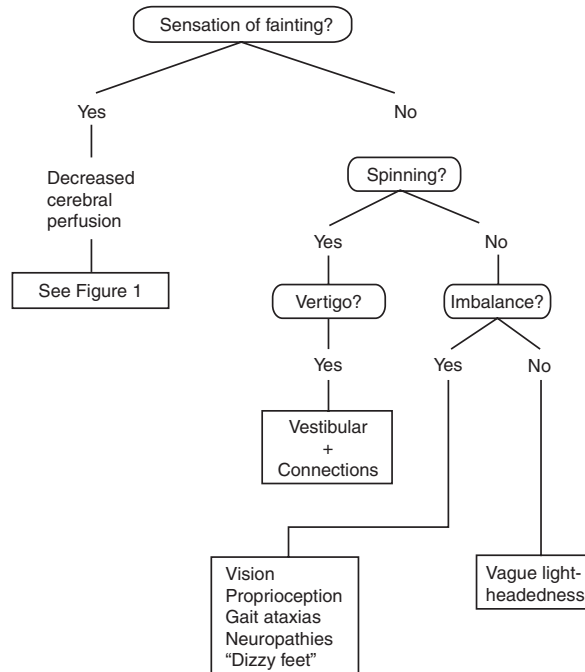

FIGURE 2 Algorithm for evaluating patients with dizziness. (Redrawn from Khan, M.G. (1996). *Heart Disease Diagnosis and Therapy: A Practical Approach*, Baltimore: Williams & Wilkins, p. 533.)

the vertebral-basilar artery causes characteristic symptoms — vertigo, diplopia, ataxia, and the loss of postural tone in the legs — that may mimic syncope.

D. Cardiac Causes

I. Tachyarrhythmias

Sustained ventricular tachycardia with a duration of greater than 3 seconds or symptomatic nonsustained ventricular tachycardia commonly causes presyncope or syncope. Amiodarone can be used in patients with structural heart disease, but an implantable cardioverter defibrillator may be necessary. Supraventricular tachycardia with fast ventricular rates (150–230 beats per minute) like in Wolff-Parkinson-White syndrome may cause syncope, and ablation therapy usually produces salutary effects.

2. Bradycardia

Bradycardia caused by sick sinus syndrome requires removal of drugs such as beta-blockers and digoxin as they slow sinus node activity. A pacemaker is probably necessary. Obstruction to intracardiac blood flow caused

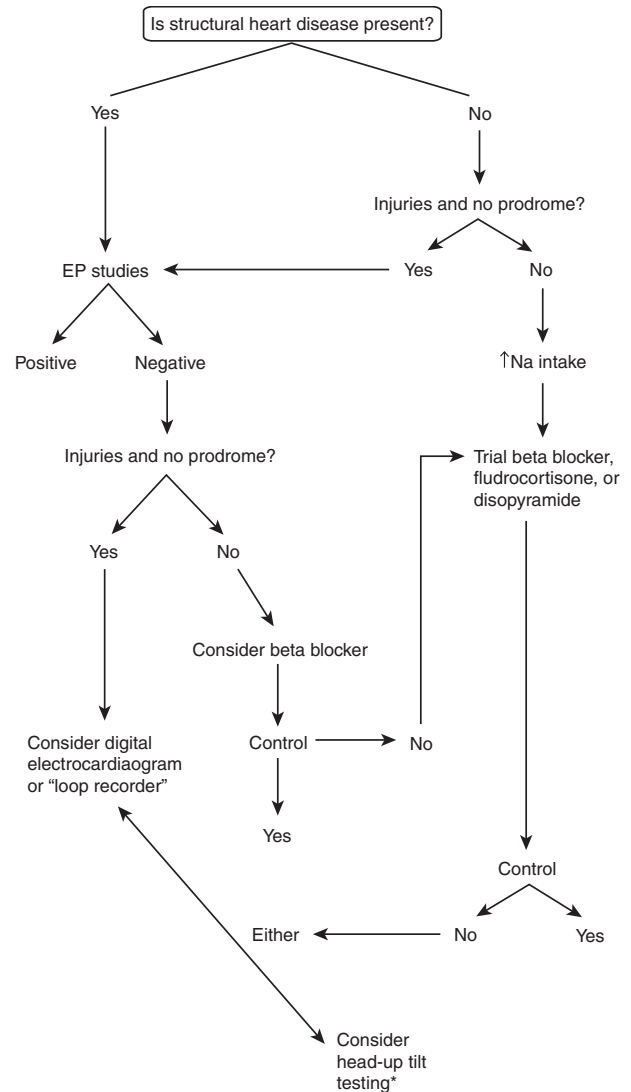

FIGURE 3 Algorithm for the management of unexplained syncope. *Use is abused; may not assist further with therapeutic strategies and is not without dangers of cortical damage. EP = electrophysiologic. (Redrawn from Khan, M. Gabriel, *Heart Disease Diagnosis and Therapy: A Practical Approach*, second edition, New Jersey, Humana Press, 2005.)

by severe aortic stenosis, mitral stenosis, or left atrial myxoma requires surgical correction.

E. Unexplained Syncope

Figure 2 gives an algorithm for the management of unexplained syncope. Patients who have unexplained syncope without a few seconds of prodrome may sustain injuries and require intensive investigations, as indicated in Fig. 2.

BIBLIOGRAPHY

- Calkins, H., and Zipes, D. P. Hypotension and syncope. In *Heart Disease*, sixth edition. E. Braunwald, ed. W. B. Saunders, Philadelphia, 2001.
- Connolly, S. J., Robert Sheldon, Kevin, E. Thorpe. et al. For the VPS II Investigators. Pacemaker therapy for prevention of syncope in patients with recurrent severe vasovagal syncope. Second vasovagal pacemaker study. *JAMA*, 289:2224–9, 2003.
- Flevari, P., Efthimios, G., Livanis, M. D. et al. Vasovagal syncope: A prospective randomized crossover evaluation of the effect of propranolol, nadolol and placebo on syncope recurrence and patients well being. *J. Am. Coll. Cardiol.*, 40:499–504, 2002.
- Kapoor, W. N. Is there an effective treatment for neurally mediated syncope? *JAMA*, 289:2272–2275, 2003.
- Kapoor, W. N. Syncope. *N. Engl. J. Med.*, 343:1856–62, 2000.
- Khan, M. G. *On Call Cardiology*. Second edition. W. B. Saunders, Philadelphia, 2001.
- Madrid, A. H., Ortega, J., Rebollo, J. G. et al. The efficacy of atenolol for the prevention of neurally mediated syncope in a highly symptomatic population: A prospective double-blind randomized placebo-controlled study. *J. Am. Coll. Cardiol.*, 37:544–9, 2001.
- Maisel, W. H., and Stevenson, W. G. Syncope — getting to the heart of the matter. *N. Engl. J. Med.*, 347:931–33, 2002.
- Moss, A. J., Schwartz, P. J. et al. 25th Anniversary of the international long-QT syndrome registry: An ongoing quest to uncover the secrets of long-QT syndrome. *Circulation*, 111:1199–1201, 2005.
- Salim, M. A., Di Sessa, T. G. et al. Effectiveness of fludrocortisone and salt in preventing syncope recurrence in children: A double-blind, placebo-controlled, randomized trial. *J. Am. Coll. Cardiol.*, 45:484–488, 2005.

Tests for Heart Diseases

- I. Electrocardiogram
- II. Exercise Treadmill Stress Test
- III. Chest X-Ray
- IV. Echocardiogram
- V. Holter Monitor
- VI. Nuclear Scans
- VII. Coronary Arteriography/Cardiac Catheterization
- VIII. Coronary Calcium Evaluation
- IX. Cardiovascular Magnetic Resonance Imaging/
Magnetic Resonance Angiography

GLOSSARY

angina chest pain caused by temporary lack of blood to an area of heart muscle cells, usually caused by severe obstruction of the artery supplying blood to the segment of cells.

atheroma same as atherosclerosis, raised plaques filled with cholesterol, calcium, and other substances on the inner wall of arteries that obstruct the lumen and the flow blood; the plaque of atheroma hardens the artery, hence the term atherosclerosis (sclerosis = hardening).

myocardial infarction death of an area of heart muscle due to blockage of a coronary artery by blood clot and atheroma: medical term for a heart attack or coronary thrombosis.

I. ELECTROCARDIOGRAM

An electrocardiogram (ECG) at rest in patients with angina is often normal but can show signs of chronic oxygen lack (ischemia) or an old scar of a healed heart attack (myocardial infarct). It may also show disturbances of the heart rhythm, that is, premature beats and electrical disturbances as well as heart enlargement. An ECG is a valuable test for patients with heart disease, but a normal ECG does not mean that the individual does not have angina coronary artery disease (CAD).

A resting ECG may show the following abnormalities:

- An acute heart attack in patients with chest pain; an ECG is still the most important test used for the diagnosis of a heart attack

- An old heart attack, which has caused a residual scar in the heart muscle
- Acute oxygen lack in patients with unstable angina
- Chronic ischemic changes due to oxygen lack or changes that indicate that the left ventricle is working under strain (see chapter entitled Angina)
- Electrical disturbances such as blocks in the electrical bundles, called right or left bundle branch block or heart block (see chapter entitled Bundle Branch Block)
- Ventricular premature beats and a variety of abnormal heart rhythms that cause palpitations (see the chapter Arrhythmias).
- Enlargement of the left or right ventricle and the left atrium (see chapter entitled Hypertension)
- A very weak area or bulge of the heart muscle (aneurysm)
- A very slow heart rate, which may indicate disease of the sinus node generator (pacemaker)

If a prior ECG is available, a comparison in pattern is most useful. Therefore, it is wise for heart patients who are traveling outside the country or state to carry a copy of their ECG while they travel. This may prevent any delay in emergency rooms and hasten discharge from the hospital. Several other disturbances are appreciated by a resting ECG such as potassium and calcium lack or excess, digoxin toxicity, pericarditis, athlete's heart, and muscle problems. Despite the advent of sophisticated and very expensive cardiologic tests, the inexpensive ECG retains its usefulness as the only reliable test used for the diagnosis of acute myocardial infarction, arrhythmias, and pericarditis, and it is a rapid screening test for myocardial ischemia. This test can also indicate the presence of a new or old heart attack (see the chapter Electrocardiography).

II. EXERCISE TREADMILL STRESS TEST

An ECG done during exercise (stress test) usually helps to confirm the diagnosis of angina and can be used for future reference to detect the progression of coronary artery disease. Treadmill test using the Bruce protocol is

very helpful in selecting patients for percutaneous coronary intervention (PCI; coronary angioplasty/intracoronary stent) or bypass surgery. A negative test in an individual who has completed 9 minutes or more of the Bruce protocol and achieved more than 85% maximal heart rate usually indicates the absence of significant obstructive coronary artery disease. Other aspects of the stress test are discussed in the chapters Exercise and the Heart and Women and Heart Disease.

III. CHEST X-RAY

A chest x-ray is usually normal in patients with angina but always abnormal in patients with heart failure. It is often abnormal in those with significant valvular disease, heart muscle disease, and congenital heart disease. It is the most important confirmatory test for the diagnosis of heart failure and indicates the extent of acute heart failure or pulmonary edema.

IV. ECHOCARDIOGRAM

The echocardiogram is a painless, noninvasive diagnostic technique that utilizes ultrasound. It gives the cardiologist a superb, simple, no-risk evaluation of the valves of the heart, the heart muscle, the force contraction of the heart muscle, and the determination of the ejection fraction. The size of each chamber can be measured and enlargement of the heart muscle can be easily defined.

Because the muscle contraction can be visualized, echocardiography is used in some patients after an acute heart attack to detect special complications. In patients with angina, an echocardiogram may show areas of abnormal left ventricular wall motion abnormalities. This test is most useful in patients with pericarditis because it detects water accumulation around the heart (pericardial effusion). Transesophageal echocardiography (TEE) is crucial for the diagnosis and management of infective endocarditis (see the chapter Echocardiography).

V. HOLTER MONITOR

The Holter monitor is utilized to detect abnormal heart rhythms in patients with coronary heart disease and other types of heart disease.[See Electrocardiography]The monitor, about the size of a paperback book, records a continuous electrocardiogram for 24 h. The instrument is strapped to the waist, and the patient returns home and carries out all normal activities, as well as sleep. After 24 h, the machine is returned to the doctor's office or hospital.

The tape is played and a recording is made. The tracings is assessed for the number of premature beats (extra beats) that occurred during this period and whether the abnormal beats require treatment. This test is requested when patients complain of palpitations with or without fainting, when the doctor detects premature beats with the stethoscope, or sees such disturbances of rhythm on the ECG. Important diagnoses obtained from assessment of ambulatory electrocardiographic recordings include the extent of ventricular premature beats, atrial premature beats, supraventricular tachycardia, the presence of atrial fibrillation and ventricular tachycardia, and bradycardia caused by sinus node dysfunction that may indicate the requirement of a pacemaker (see chapter entitled Hrrhythmias/Palpitations and the chapter entitled Pacemakers).

VI. NUCLEAR SCANS

The thallium or other radioisotope scan is useful in selected patients with angina to show the areas of the heart muscle that are poorly perfused with blood. This technique is simple and painless. During an exercise stress test, usually on the treadmill, a known minute amount of radioisotope, thallium-201, is injected into a vein. The isotope reaches the heart and is distributed through the coronary arteries. The areas of the heart muscle that are not receiving adequate blood flow because of blockage of the coronary arteries will receive less thallium, and these areas are assessed by special scanners.

Errors in method and interpretation limit the usefulness of this test. It is not sufficiently sensitive or specific for coronary heart disease. Nuclear scans are expensive and time-consuming, and the information gained is often not sufficiently accurate. Health-care costs can be contained if such tests are limited. These tests should be done only when treatment decisions can be appropriately altered by their results.

Single photon emission computerized tomography (SPECT) uses a scanner plus tomography. Other radioisotopes (e.g., Tc-99 m sestamibi) have replaced thallium in several laboratories, and SPECT complements exercise treadmill stress testing.

Positron emission tomography (PET) is an extremely expensive test. The advantages over SPECT need to be determined by studies to justify the high cost. The Persantine rubidium stress test is appropriate in patients who are unable to perform an exercise treadmill test and walk sufficiently to achieve more than 85% maximal heart rate.

Nuclear scans give only clues to the presence of cardiac disease and have limited value in making decisions that relate to the choice of treatment for the patient. False-positive tests are common. In most instances the cost of these tests is not justifiable. If the ECG is normal in a patient with unstable angina a nuclear scan would be helpful. If a patient can do 9 minutes on an ECG treadmill test using the Bruce protocol, or can achieve more than 85% maximal heart rate without manifesting signs of ischemia, then a nuclear scan is not expected to add valuable information that will alter treatment strategies. Nuclear cardiac imaging is widely performed, but the test is limited by a variable sensitivity and specificity and unfortunately *exposes the patient to a very high radiation exposure*. Additionally, the test is a time-consuming protocol.

Another relatively noninvasive test that gives a good estimation of how much blood the heart ejects with each beat (ejection fraction) is the gated cardiac scan. With each beat the normal heart expels at least 50% of the blood contained in each ventricle. The percentage ejected is called the ejection fraction (EF) and it is one of the best indicators of the efficiency and strength of heart contraction. Normal EF is between 50 and 75%.

The EF is one of the most important measurements used by the cardiologist to judge the strength or functional capacity of the heart. It is accurately measured during coronary arteriography, and with a similar degree of accuracy, it can be determined with the gated cardiac pool study. In this test a radioisotope, technetium, is injected into an arm vein. The isotope then binds to red blood cells and reaches the chambers of the heart. The left ventricle is well seen with sophisticated scintillation cameras and the data is processed by computer. The force of contraction and the motion of the heart muscle wall is visualized on a video screen. If the muscle is contracting poorly or contracting abnormally, as might be expected with an aneurysm, this can be detected in many cases. This test does not show structure inside the heart. Visualization of structures such as valves inside the heart and an ejection fraction can be obtained with an echocardiogram. The echocardiogram is used more often, but a gated scan is more accurate for EF measurement.

VII. CORONARY ARTERIOGRAPHY/ CARDIAC CATHETERIZATION

A. Historical

Cardiac catheterization is probably the greatest technologic innovation provided to cardiologists. It is often the final

diagnostic test used to establish the diagnosis prior to cardiac surgical operations. Caude Bernard was the first to perform the procedure in 1844, and he is responsible for naming it cardiac catheterization.

Very little was made of the procedure until 1929 when Forssmann, a surgical resident in Germany, exposed a vein in his left arm and threaded a ureteral catheter into the right atrium. He recorded this insertion with a chest x-ray. The physiologic use of the procedure had clinical applications but was not actively pursued until Cournand arrived at Bellevue Hospital in New York in 1936 and began intensive studies and experimentation with the procedure. His work with others through 1945 improved the technical aspects and developed a double-lumen catheter. The late Sir John McMichael, motivated by Cournand's group, introduced cardiac catheterization into the UK.

Left heart catheterization was accomplished in 1950 by Zimmerman who inserted a 6F catheter devised by Cournand into the exposed ulnar artery in the forearm. Mason Sones deserves the credit for developing the technique of selective coronary arteriography in 1958. The Sones technique utilizes an antecubital incision over the brachial artery that is exposed, and the catheter is then inserted and passed to the aortic root and up to the coronary orifices. This technique avoids aortoiliac disease but requires an arteriotomy and, finally, arterial closure.

Seldinger accomplished a percutaneous insertion technique that avoids exposure of an artery. This technique was mastered and propagated by Judkins in 1967. This technique introduced the catheter into the unexposed femoral artery in the groin. This procedure is used today for coronary arteriography. It is interesting that Judkins was a family physician assigned to a military post that needed urologists. Judkins was fascinated with ureteral catheters. He spent a year in Sweden with one of the leading vascular radiologists and subsequently developed the Judkins technique of coronary arteriography.

B. Technique for Cardiac Catheterization Coronary Arteriography

Prior to undergoing this technique, the patient is usually advised not to eat solid food after midnight on the day of the examination. Fluids are allowed up to one hour prior to the procedure. The patient is sedated with 5 mg of diazepam (Valium) given orally. The procedure is carried out in a cardiac catheterization laboratory under sterile conditions. The most common sites for inserting the wire or hollow plastic catheter are in the femoral artery located in the groin or the artery in the arm at the elbow. These sites are preferred because the blood vessels are large and close to the skin surface.

The pulsation of the artery is easily felt and the skin is injection with anesthetic. When the skin is frozen and painless, a needle followed by thin wires is used to introduce the catheter into the artery (Judkins technique) without exposing or incising the artery as is done with the Sones technique (the Sones technique was used mainly from 1966 to 1975). The catheter is then guided into the aorta and then into the cavity of the left ventricle. The catheter position is visualized at all times with the aid of an x-ray fluoroscope, which shows the catheter on a screen. The same technique is utilized for performing coronary arteriography (angiograms) or for studying the heart valves and pressures inside the heart chambers.

The catheter is introduced and passed under x-ray guidance to the aorta and finally to the area where the aorta leaves the heart (aortic root). At this point, the coronary arteries usually branch from the aorta, and the catheter is directed into the left and then the right coronary artery. A dye is injected and can be visualized by means of several x-rays taken in different planes. The x-rays will show the heart and arteries including the normal ones or ones with blockage by plaques of atheroma (see the chapter Atherosclerosis/Atherothrombosis). Any blockage in the coronary artery is clearly visualized. Coronary arteriography is a relatively safe procedure in experienced hands when done in well-equipped laboratories. Mortality is less than 0.05% and minor complications are rare.

Because the procedure is not without complications, the test must be justifiable and the patient must be aware of the associated risks. Patients are usually very keen to have the procedure because they understand it is the only way to know, without a doubt, the extent and severity of their coronary obstruction. Angioplasty or surgery cannot be done without first visually examining the vessels, which is done with cardiac catheterization (an x-ray movie is made and can be replayed during surgery to show the blockages).

For coronary angioplasty, a specialized catheter is used. It has a double lumen and a small inflatable balloon at the tip. The length of the balloon is about 2.5 cm and the inflated diameter is 2–4 mm. The catheter is guided into the appropriate coronary artery to the obstruction previously visualized by coronary arteriography. During coronary arteriography, dye that looks white on x-ray film (radio-opaque) is injected into a catheter positioned selectively in the right and the left coronary arteries.

All patients undergoing coronary angioplasty or coronary artery bypass surgery must have coronary arteriography to show the cardiologist or surgeon the exact site of blockage by a plaque of atheroma (see Fig. 1 in the chapter Coronary Artery Bypass Surgery). Arteriography can be done several hours or days prior to PCI, surgery, or other procedures.

C. Indications

The most important reason to have this test is the presence of angina (see the chapter Angina) that interferes with lifestyle to such an extent that it is deemed unacceptable by the patient and the physician. The majority of patients with stable angina are able to live with the occasional occurrence of the fleeting chest discomfort that they know will be precipitated by a particular exertion or emotion. They realize that the pain does not damage the heart muscle and that on stopping the precipitating activity, pain or discomfort disappears immediately or is quickly relieved by a nitroglycerin tablet. Such patients may learn to live with angina for 20 years and nothing else is done. Symptoms can be further improved in many by the use of beta-blockers and in some with the addition of an oral nitrate or calcium blocker. The combination of drugs greatly reduces the occurrence of chest pain. In a few patients with stable angina, pain may occur daily and can interfere with work or lifestyle. Despite the fleeting nature of the pain, the patient may not be satisfied to live with this annoyance and may ask, "What else can be done?" The doctor in many cases may suggest that a coronary arteriogram be performed.

Patients with unstable angina will need coronary angiograms within a few weeks or months after their pain has subsided. The majority of these patients will need to undergo coronary angioplasty or bypass surgery. If surgery is contraindicated because of other medical problems or age, then there is little point to submit the patient to the test.

There are a few patients in whom the diagnosis of angina is confusing, especially when symptoms of reflux esophagitis make the diagnosis difficult. Coronary arteriograms may be necessary to unravel the mystery and prevent patients from becoming cardiac cripples.

Again, the main reason for having a coronary arteriogram is to show what part of the coronary artery is blocked and to what extent, so it can be determined whether the individual is a candidate for PCI or coronary artery bypass surgery (see the figures in the chapter Coronary Artery Bypass Surgery).

Coronary arteriography remains the most important method of defining the presence and severity of atherosclerosis of the coronary artery and it gives an assessment for valvular stenosis or regurgitation (see chapter entitled Valve Diseases). This test also reveals the size and shape of the left ventricle, its ability to contract evenly and forcibly, and any problems with valves in the heart. More than one million coronary arteriograms are performed in the United States annually. The procedure is not painful, and depending on the center, the patient is usually admitted

the night before, the tests are done the next day, and the patient is discharged later that afternoon. In many institutions, facilities exist for a substantial number of patients to have the test done during the day with discharge several hours later if the condition is satisfactory.

VIII. CORONARY CALCIUM EVALUATION

A. Electron Beam Tomography

Coronary calcium scanning is available by electron beam tomography (EBT) multidetector scanners (MDCT) and magnetic resonance imaging (MRI). Coronary CT scans can detect and quantitate the presence of coronary artery calcium deposits with ECG-gated images obtained with either electron beam computed tomography (EBTC) or helical CT scanners. The entire test takes less than 15 minutes to complete, but *unfortunately exposes the patient to a moderate amount of ionizing radiation equal to approximately 10–15 standard chest radiographs*. EBTC is faster and more accurate for calcium scores than spiral CT. Cardiac motion during imaging distorts CT image density and calcium scores by spiral CT are generally higher than those from EBTC, thus potentially corrupting the validity of a zero score. The EBTC uses an electron sweep of stationary tungsten target rings to generate x-ray images that can detect small amounts of calcium with considerable accuracy, whereas helical CT uses a continuously rotating x-ray source.

At the present time calcium scoring by spiral CT should not be considered comparable to EBTC, especially because of the clinical connotation of a zero score. A total calcium score of zero from EBTC should be highly predictive of the absence of obstructive coronary artery disease, but approximately 90% of men and 70% of women age 60–75 have coronary calcification that is nonspecific. Thus in this age group the search for zero scores is an expensive one.

The amount of calcium in the coronary arteries correlates to some degree with the amount of atherosclerotic plaque. The absence of calcium does not exclude plaque formation, however, because less than 50% of plaques are calcified. The specificity of this test is poor with less than 23% in men and less than 40% in women.

In the age group where the tests could be most valuable (age 50–70), approximately 90% of men and 70% of women have coronary artery calcification and it is impossible to say if this means anything. EBTC is unlikely to be of value in young, asymptomatic individuals age 30–50 who have no risk factors or in those with multiple risk factors such as dyslipidemia, diabetes, hypertension, smoking, or strong family history of coronary artery

disease. Most important this test is not required in patients at high risk for coronary events or those with multiple risk factors, because these individuals require cardiac investigations beyond the estimation of calcium scores.

EBTC adds little to the results of a clearly normal or clearly abnormal treadmill exercise test. If the treadmill test is equivocal, EBCT may have a role; in such individuals less than age 60 a negative EBCT (zero calcium score) probably indicates a noncardiac cause for symptoms or low probability risk for coronary events. If the test shows high calcium scores then ~20% of men and ~40% of women are expected to have significant coronary lesions. This low specificity presents a major obstacle for the development of a strategic algorithm.

EBCT should be used in selected individuals only if the initial stress test (treadmill stress test or stress plus nuclear imaging, pharmacologic stress test with nuclear imaging, echocardiographic stress test) results are equivocal or nondiagnostic. This test has been much abused and will continue to be misused at a high cost to patients, especially if it is used in the battery of (batter-selection, batch of tests) initial test in asymptomatic individuals or in low-to-intermediate risk patients. Additionally, this test is not indicated in patients with angina and in high-risk patients or in those with multiple risk factors. An American Heart Association Prevention V conference indicated that individuals of intermediate cardiovascular risk may be appropriate candidates for coronary calcium screening. A calcium score of >400 or above the 75th percentile for age and gender generally represents a clinically significant positive test, and it is suggested that these individuals should be further investigated by exercise or nuclear stress tests.

A recent task Force (#4, Wilson et al.) report states:

Despite the lack of consistent recommendations, the current practice by numerous physicians is to consider a significant calcium score to warrant atherosclerosis that must be treated aggressively, as in the case a person with known coronary artery disease. It will be several years before the results of the NIH-sponsored MESA are published. The study investigates the incremental value of CT coronary calcium scores for prediction of cardiovascular events over both standard and novel coronary risk factors.

IX. CARDIOVASCULAR MAGNETIC RESONANCE IMAGING/MAGNETIC RESONANCE ANGIOGRAPHY

High-resolution cardiovascular magnetic resonance imaging (CMR) is providing major advances for atherosclerotic

plaque imaging and characterization. Various plaque components such as the thickness of the fibrous cap, necrotic core, lipid composition, calcium, and other parameters can be differentiated with CMR. The detection of total coronary plaque burden is being evaluated in studies. CMR has the unique, but unproven, potential to morphologically characterize the vulnerability of atheromatous plaques. Use of CMR is likely the greatest potential for future developments in the field.

In a small study CMR was shown to accurately diagnose 21 of 25 patients (84%) determined to have acute coronary syndrome — a slightly higher level of sensitivity than ECG criteria and blood enzyme levels. This test appeared to be more specific than an abnormal ECG in patients with unstable angina and non-ST segment elevation myocardial infarction. When available, CMR may have a role in selected intermediate-risk patients admitted to the emergency room with acute coronary syndrome not diagnosed by ECG and enzyme blood levels. The use of this expensive test, if it becomes available, should not be abused. Many patients presenting with so-called acute coronary syndrome who turn out not to have significant unstable coronary artery disease are discharged appropriately from emergency rooms based on the history, clinical findings, ECG, and troponin levels done on admission and 6 h later. Less than 1% of the large number of patients presenting with chest pain with acute coronary syndrome who are subsequently shown to have acute myocardial infarction are discharged from emergency rooms without the event detected.

A. Clinical Study: Kim et al.

Study question: An accurate noninvasive technique for the diagnosis of coronary artery disease would be an important advance. The study's authors investigated the accuracy of magnetic resonance angiography (MRA) among patients with suspected coronary artery disease in a prospective multicenter study.

Methods: MRA was performed during free breathing in 109 patients before coronary angiography and the two diagnostic procedures were compared.

Results: A total of 636 of 759 proximal and middle segments of coronary arteries (84%) were interpreted on MRA. In these segments 78 (83%) of 94 clinically significant lesions (those with a greater than 50% reduction in diameter on angiography) were also detected by MRA. Coronary MRA had an accuracy of 72% in

diagnosing coronary artery disease. The sensitivity and specificity and accuracy for patients with disease of the left main coronary artery or three-vessel disease were 100% percent and 87%, respectively. The negative predictive values for any coronary artery disease, left main, or three-vessel disease were 81 and 100%, respectively. The majority of individuals had a history of chest pain, hypercholesterolemia, and smoking, and 59% had angiographic evidence of coronary artery disease. The mean total scanning time was 70 minutes.

Conclusions: This noninvasive approach reliably identifies or rules out left main coronary artery or three-vessel disease. MRA was unable to assess 16% of coronary segments and 6% of the study patients could not be assessed for the presence of left main or three-vessel disease.

BIBLIOGRAPHY

- Budoff, M. J., Achenbach, S., and Duerinckx, A. Clinical utility of computed tomography and magnetic resonance techniques for noninvasive coronary angiography. *J. Am. Coll. Cardiol.*, 42:1867–1878, 2003.
- Fayad, Z. A., and Fuster V. The human high-risk plaque and its detection by magnetic resonance imaging. *Am. J. Cardiol.*, 88:42E–5E, 2001.
- Greeland, P., and Gaziano, M. C. Selecting asymptomatic patients for coronary computed tomography or electrocardiographic exercise testing. *N. Engl. J. Med.*, 349:465–73, 2003.
- Haberl, R., Becker, A., Leber, A. et al. Correlation of coronary calcification and angiographically documented stenoses in patients with suspected coronary artery disease: Results of 1764 patients. *J. Am. Coll. Cardiol.*, 37:451–7, 2001.
- Kim, W. Y., Danias, P. G., Stuber, M. et al. Coronary magnetic resonance angiography for the detection of coronary stenoses. *N. Engl. J. Med.*, 345:1863–9, 2001.
- Klocke, F. J., Baird, M. G., Lorell, B. H. et al. ACC/AHA/ASNC guidelines for the clinical use of cardiac radionuclide imaging—Executive summary: A report of the American College of Cardiology/American Heart Association Task Force on practice guidelines (ACC/AHA/ASNC Committee to Revise the 1995 Guidelines for the Clinical Use of Cardiac Radionuclide Imaging). *Circulation*, 108:1404–1418, Sep 2003.
- Loscalzo, J., Bonow, R. O., Jacobs, A. K. et al. Coronary calcium screening and the American Heart Association news embargo. *Circulation*, 110:3504–3505, 2004.
- Maceira, A. M., Joshi, J., Prasad, S. K. et al. Cardiovascular magnetic resonance in cardiac amyloidosis. *Circulation*, 111:186–193, 2005.
- Maintz, D., Botnar, R. M., Manning, W. J. et al. Pitfalls in coronary magnetic resonance angiography: Right coronary artery occlusion. *Circulation*, 111:e94–e96, 2005.
- Morin, R. L., Gerber, T. C., McCollough, C. H. et al. Radiation dose in computed tomography of the heart. *Circulation*, 107:917–922, Feb 2003.
- Redberg, R. F., Vogel, R. A., Criqui, M. H. et al. Task Force #3 — What is the spectrum of current and imaging techniques for the noninvasive

- measurement of atherosclerosis? *J. Am. Coll. Cardiol.*, 41:1855–917, 2003.
- Rumberger, J. A. Electron beam tomography quantitation of coronary calcium and assessment for ischemic coronary disease: A complement to stress testing. *J. Am. Coll. Cardiol. ACC Curr. J. Rev.*, Nov/Dec, 32–58, 2001.
- Wilson, P. W. F., Smith, S. C., Blumenthal, R. S. et al. Task Force #4 — How do we select patients for atherosclerosis imaging? *J. Am. Coll. Cardiol.*, 41:1898–917, 2003.
- Wong, N. D. Detection of subclinical atherosclerosis: Implications for evaluating cardiovascular risk. *ACC Curr. J. Rev.*, March 2004.

Thyroid Heart Disease

- I. High Thyroid (Hyperthyroidism)
- II. Low Thyroid (Hypothyroidism)
- III. Amiodarone-Induced Thyroid Dysfunction

GLOSSARY

- angina** chest pain caused by temporary lack of blood to an area of heart muscle cells, usually caused by severe obstruction of the artery supplying blood to the segment of cells.
- heart failure** failure of the heart to pump suction blood from the chambers into the aorta; inadequate supply of blood reaches organs and tissues.

I. HIGH THYROID (HYPERTHYROIDISM)

A. Symptoms

The thyroid gland in the neck may suddenly become overactive and secrete excessive amounts of the hormone thyroxine. This situation is common between age 20 and 50; it can also occur later in life. Excessive thyroxine causes increased metabolism of all tissues, therefore, weight loss can occur, despite a good appetite and food intake. Individuals feel nervous, anxious, irritable, and have intolerance to heat. Shortness of breath, palpitations, tachycardia, and systolic hypertension are often observed.

Other symptoms include the heart beating faster and contracting more vigorously, and the pulse rate may be 110–130 beats per minute at rest. Sinus tachycardia is present in more than 40% of patients and approximately 15% develop transient atrial fibrillation followed by persistent atrial fibrillation. In patients with heart disease and underlying left ventricular dysfunction, the extra work imposed on the heart by hyperthyroidism may precipitate heart failure. In patients with coronary artery disease, mild angina may be precipitated.

B. Physical Signs

The thyroid gland may become slightly enlarged and a bruit may be heard when the stethoscope is placed over the gland. Protrusion of the eyeballs (exophthalmos) may be pronounced and lid lag may be observed. The hands become warm and sweaty also. Sinus tachycardia, a hyperkinetic cardiac apex, and a loud first heart sound may be accompanied by soft flow murmurs.

C. Treatment

Tachycardia may require control with a beta-blocker until treatment with radioactive iodine causes destruction of the gland. Surgery is now rarely used.

II. LOW THYROID (HYPOTHYROIDISM)

A. Symptoms and Signs

This problem is common in the elderly but can occasionally affect individuals age 20 to 60. Lack of the hormone thyroxine causes weight gain; constipation; lethargy; sleepiness; a hoarse voice; dry, puffy skin; and intolerance to cold. Hypothyroidism or myxedema, causes bradycardia. The pathologic heart in severe myxedema appears pale, flabby, and grossly dilated. A pericardial effusion may be present and microscopic examination shows myofibrillar swelling and interstitial fibrosis. Cardiac enlargement, low electrocardiographic voltage, nonpitting facial and peripheral edema, and signs of congestive heart failure are now rarely seen because of early diagnosis and treatment, but exertional dyspnea and easy fatigability are common symptoms.

Patients who have hyperthyroidism treated with radioactive iodine or surgery become hypothyroid after 10–20 years and require treatment. Thus, hypothyroidism is a

common condition in the elderly. The disease can exist for many years before it is recognized by patients or detected by physicians. A simple blood test, sensitive TSH, rapidly and accurately identifies patients who have hypo- and hyperthyroidism.

Hypercholesterolemia and hypertriglyceridemia are often found in patients with hyperthyroidism and is associated with development of premature coronary artery disease. Treatment of the hypothyroid condition corrects the lipid abnormalities.

B. Treatment

Patients with hypothyroidism require replacement therapy with thyroxine, usually a dosage of 0.05–0.2 mg daily (50–200 µg).

III. AMIODARONE-INDUCED THYROID DYSFUNCTION

The widespread use of amiodarone for the management of cardiac arrhythmias is a common cause of thyroid abnormalities in patients with heart disease. Amiodarone has structural similarities to T₄ and T₃ and is also rich in

iodine. Abnormal thyroid function tests (low TSH and elevated T₄) may be observed with the chronic use of amiodarone, but they are often not associated with clinical manifestations of thyroid dysfunction.

Hypothyroidism is precipitated in approximately 15% of patients on chronic amiodarone therapy as observed in the United States, the UK, and Europe. Hyperthyroidism is less common in these countries and is observed more often in developing countries due to iodine deficiency. The finding of weight loss, heat intolerance, and tremor should alert suspicion, but the first symptom may be a cardiac arrhythmia with rapid heart rate. The finding of a low TSH, an elevated T₄, and an increased T₃ is diagnostic of amiodarone-induced hyperthyroidism.

BIBLIOGRAPHY

- Ripoli, A., Pingitore, A., Favilli, B. et al. Does subclinical hypothyroidism affect cardiac pump performance? *J. Am. Coll. Cardiol.*, 45:439–445, 2005.
- Sleely, E. W., and Williams, G. H. The heart in endocrine disorders. In *Heart Disease, a Textbook of Cardiovascular Medicine*, sixth edition. E. Braunwald, D. P. Zipes, and P. Libby, eds. W. B. Saunders, Philadelphia, 2001.

Valve Diseases

- I. Murmurs
- II. Causes and Consequences of Valve Disease
- III. Rheumatic Fever
- IV. Specific Valve Lesions
- V. Prosthetic Valve Choice

GLOSSARY

angina chest pain caused by temporary lack of blood to an area of heart muscle cells, usually caused by severe obstruction of the artery supplying blood to the segment of cells.

arrhythmia general term for an irregularity or rapidity of the heartbeat, an abnormal heart rhythm.

heart failure failure of the heart to pump sufficient blood from the chambers into the aorta; inadequate supply of blood reaches organs and tissues.

murmur a blowing sound heard with a stethoscope usually caused by obstruction of heart valves or leaking valves.

THE VALVES OF THE HEART (SEE FIG. 1) ARE like automatic doors, which open when people want to pass through and stay shut when not in use. When blood must be expelled from the left ventricle into the aorta, the aortic valve, the main valve, opens. The texture of valves is as smooth as silk, thus blood particles and bacteria do not adhere to them. Valves may be the site of disease, however, thus the term valvular heart disease.

I. MURMURS

When affected by disease, the soft heart valve tissue gets rough, thick, swollen, and hard. As blood rushes through the obstructing or damaged valves, turbulence occurs. This turbulence sets up vibrations that are louder than normal and can be heard easily with a stethoscope. The sound heard by the stethoscope is called a murmur (see the chapter Murmurs).

The loudness of a murmur depends on the velocity of blood flow, the amount of blood passing across the deformed valve, and the turbulence that occurs. A cardiologist, using the simple stethoscope and without expensive tests, can tell if a murmur is significant. An echocardiogram confirms this observation, but is often unnecessary if the doctor is well trained in the use of a stethoscope. The echocardiogram may display murmurs that are not significant and may create unnecessary worry for individuals.

Murmurs are most commonly systolic in time; that is, they occur during the contraction of the ventricles. Many systolic murmurs are not significant in that they do not disturb the function of the heart. Murmurs that occur when the ventricles are relaxed, that is, during diastole, are termed diastolic murmurs and are always of significance.

Over a period of 5–50 years, significant murmurs increase the work of the heart muscle and cause it to enlarge. The muscle finally becomes weak and heart failure occurs. When severe heart failure occurs, disability occurs. (see the chapter Heart Failure.)

II. CAUSES AND CONSEQUENCES OF VALVE DISEASE

A. Causes

Damage to heart valves is caused by:

- Rheumatic fever
- Infections such as bacterial endocarditis and syphilis; viral infections, though extremely common, are not known to cause valve disease
- Mitral valve prolapse
- Degenerative diseases due to age changes, such as calcific aortic sclerosis
- Congenital heart disease (see the chapter Congenital Heart Disease)
- Complications of coronary artery disease and cardiomyopathy

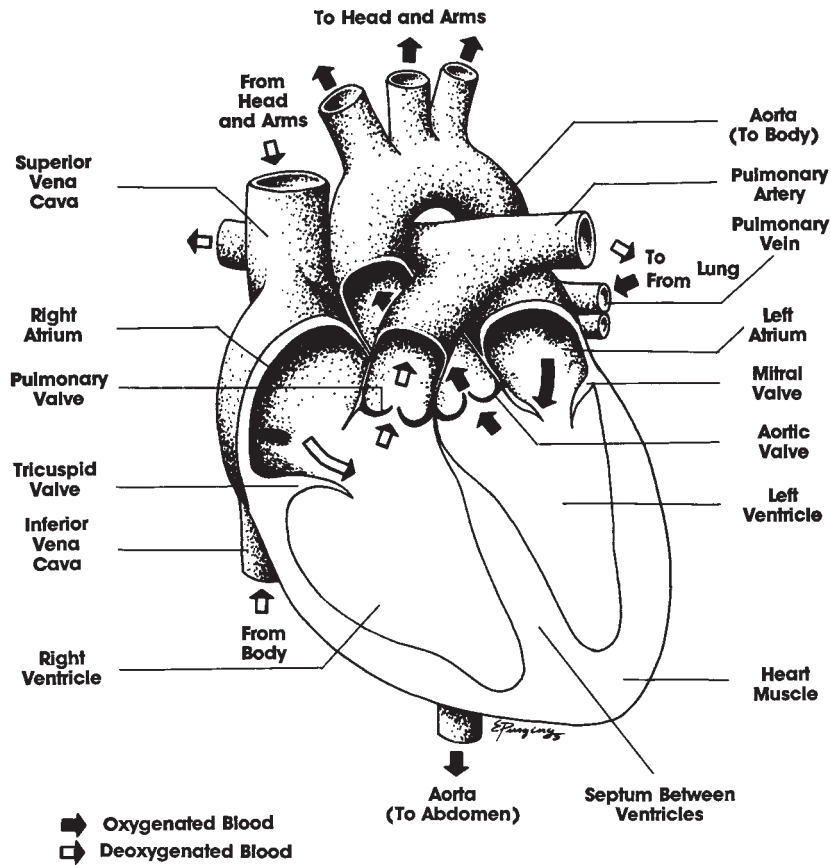

FIGURE 1 Structure of the heart. (From Khan, M. Gabriel and Marriott, H. J. L. (1996). *Heart Trouble Encyclopedia*, Toronto: Stoddart Publishing, p. 267.)

B. Consequences

Bacterial endocarditis may occur in patients with valve disease. Complications due to blockage of the valve (stenosis) or backward leak (regurgitation or incompetent valve) of blood may cause severe shortness of breath. Roughness of the valve may also extend into the chamber of the left atrium and set up electrical discharges. Thus arrhythmias such as premature beats, paroxysmal atrial tachycardia, and atrial fibrillation may occur.

The major symptoms of serious valve disease are increasing shortness of breath on mild exertion and on lying flat, cough, and occasionally blood-tinged sputum (hemoptysis). Finally, signs of heart failure occur. These include severe shortness of breath, edema of the legs, and water in and around the lungs (see the chapter Heart Failure).

A tight valve is medically called a stenosis, thus the terms “mitral stenosis” and “aortic stenosis.” A leaky valve indicates regurgitation of blood, and the two common lesions are mitral regurgitation and aortic regurgitation. The pulmonary and tricuspid valves are rarely affected except

when due to congenital heart disease or infection caused by endocarditis as seen in drug addicts.

III. RHEUMATIC FEVER

A. Types of Valve Damage

Damage to heart valves often occurs during an attack of rheumatic fever. Rheumatic fever is most common between the ages of 5 and 25 and occurs in susceptible individuals after a beta-hemolytic streptococcal sore throat. The streptococcus bacterium sets up an allergic-like reaction on the valves and in the joints. There is usually fever and joint pains and murmurs are heard over the swollen heart valves. A blood test to show a reaction to the streptococcus usually confirms the diagnosis.

Fortunately, sore throats caused by this particular strain of streptococcus have become much less common and the disease is disappearing from North America. It still persists in third-world countries.

Not all individuals who get rheumatic fever develop damage to the heart valves. Those who have severe fever with severe joint pains lasting several months may never get valve damage. The opposite is most likely to occur; it appears that when rheumatic fever “licks the joints it spares the heart.” More than 40% of patients may not recall having had an illness with fever and joint pains yet their valves may be affected by minor streptococcal infection.

The mitral valve is affected most often followed by the aortic valve, causing conditions called mitral stenosis and regurgitation or aortic stenosis and regurgitation. Other valves rarely get damaged by rheumatic fever or degenerative disease.

B. Prevention of Rheumatic Fever

Rheumatic fever tends to recur in the same individual because of a predisposition to the disease. In order to prevent recurrence, the following is advised:

1. If rheumatic fever was properly documented, but there is no evidence of significant valve damage, penicillin is usually given for a minimum of 5 years or to age 20, whichever is longest.
2. If the heart valve was damaged, penicillin is given for a minimum of 10 years or to age 40, whichever is the longest.
3. Depending on the state or country, and the prevalence of beta-hemolytic streptococci and rheumatic fever, some physicians continue treatment beyond age 40. The dose of antibiotic is usually penicillin V 250 mg twice daily.
4. If the patient is allergic to penicillin, sulfadiazine is as effective and is given 1 g once daily for adults and 0.5 g daily for patients weighing less than 60 pounds. If penicillin V is not given, then 1.2 million units of benzathine penicillin G intramuscularly is given monthly.

IV. SPECIFIC VALVE LESIONS

A. Mitral Stenosis

1. Symptoms

The silky, soft leaflets of the mitral valve become thickened, rough, and hard, and over a few years the orifice of the valve becomes tight. Blood in the left atrium has difficulty getting through the mitral valve to reach the left ventricle (see Fig. 1). Patients with mild mitral stenosis have a valve area 1.6 to 2 cm² and may develop mild shortness of breath on moderate-to-severe exertion, but lifestyle is

not altered. Symptoms progress slowly over 5–10 years. Shortness of breath may worsen suddenly because of chest infection, pregnancy, and tachycardias (atrial fibrillation is a common complication).

Patients with moderately severe mitral stenosis with a valve area of 1–1.5 cm² usually have symptoms that affect or interfere with daily living. Shortness of breath caused by progressive pulmonary venous hypertension and congestion of blood in the lungs become bothersome. Breathlessness is precipitated by moderate activity such as briskly walking 100 yards or walking up two flights of stairs. Cough, shortness of breath, wheezing, and hemoptysis may mimic bronchitis for several months because the subtle signs of mitral stenosis can be missed by the untrained physician.

Severe mitral stenosis with a valve area less than 1 cm² usually causes bothersome symptoms such as progressive shortness of breath, palpitations, marked fatigue, cough, hemoptysis, and hoarseness may occur during mild activity. Chest pain may be the presenting feature, but progression may be rapid with development of heart failure manifested by bilateral leg edema and shortness of breath in bed (orthopnea). The patient may awaken from sleep and may need to sit at the side of the bed for several minutes to get relief (paroxysmal nocturnal dyspnea). Progression to heart failure with life-threatening pulmonary edema may be precipitated by pregnancy or atrial fibrillation, a situation in which the rapid beating of the heart does not allow proper filling of the ventricle because of the tightly obstructed valve.

2. Physical Signs

On examination of the heart particular signs of mitral stenosis are usually present. The apex beat is tapping in quality and is not usually displaced except if concomitant mitral regurgitation or other valve lesions are present. A lower left parasternal heave may be seen or felt caused by right ventricle hypertrophy brought on by the pulmonary hypertension. Auscultation reveals a loud slapping first heart sound that is typical with an opening snap that is followed by a low-pitched murmur, and a mid-diastolic rumble that is a characteristic of mitral stenosis. If sinus rhythm is present the murmur increases intensity just prior to the first heart sound. This is called presystolic accentuation. This murmur is best heard with the bell of the stethoscope with the patient lying on the left side.

3. Investigations

Chest x-ray shows straightening of the left heart border due to enlargement of the left atrium. ECG shows left atrial enlargement. Echocardiography is diagnostic and tightness

(stenosis) of the valve can be graded as mild ($1.6\text{--}2\text{ cm}^2$), moderate ($1\text{--}1.5\text{ cm}^2$), or severe ($<1\text{ cm}^2$).

4. Therapy

Percutaneous balloon mitral valvuloplasty is indicated for symptomatic patients with moderate-to-severe mitral stenosis with a valve orifice less than 1 cm^2 . This procedure has superseded surgical valvotomy and gives equally good results, but patients must be carefully selected. Success is assured in patients with pliable valve leaflets, that is, little or no significant calcification or subvalvular fibrosis and absence of mitral regurgitation as determined by transeophageal echocardiography (TEE).

Valvuloplasty involves passing a catheter and guidewire through the artery from the groin into the heart to the tight valve, which is then snapped open with a balloon-tipped catheter. This procedure is highly successful and is suitable for more than 75% of patients. If this procedure cannot be done, surgery is recommended.

One complication of valvuloplasty is an atrial septal defect in more than 50% of cases, but this defect is not significant and the majority close after 6 months. Mortality is about 2.5% and the restenosis rate is approximately 12% at 3 years, similar to that of surgical valvotomy.

Valvotomy is relatively simple and safe; the valve is opened with a finger-like special metal dilator. In a few cases the valve may also have a leaking problem and must be replaced by a prosthesis. The results of surgery are excellent but reserved for patients with severe symptoms and in whom valvuloplasty is not feasible. Many patients can live 5–30 years with mild-to-moderate symptoms before they become serious enough to warrant valvuloplasty or surgery. Complications are rare except when atrial fibrillation occurs. Digoxin and an anticoagulant are then required.

5. Case History

At age 29 Mrs. J. B. started having a cough with shortness of breath, mainly when climbing stairs. Over the next few weeks, symptoms occurred at night in bed. Cough, shortness of breath, and wheezing became worse over the next month, and her family doctor prescribed cough medicine. About one month later there was no improvement. At night she would have difficulty breathing and would have to sit up for a 30–60 minutes to get some relief. The second visit to the doctor resulted in a 12-day course of antibiotics and another cough medicine to clear the chest infection or congestion in the lungs.

Several weeks later she was no better; more cough medicine was prescribed along with an inhaler to try and relieve her bronchial spasms. There was no fever or chills.

At this stage she had difficulty doing her housework and climbing stairs, chiefly because of shortness of breath and cough. She noted that her sputum was tinged with blood at times. She smoked 20–30 cigarettes per day and was advised to give this up since she had bronchitis and congestion.

At this stage she was referred to the cardiologist. She had the typical heart sounds and murmur of mitral stenosis. The valve was extremely tight, and blood was backing up, congesting and flooding the lungs. She was admitted to the hospital that day. Her shortness of breath was relieved 50% by the diuretic furosemide and she was able to sleep. Her blood-tinged sputum disappeared over the next few days, and three weeks later she had a heart catheterization. Cardiac surgery was performed the next month, the valve was opened, and 20 years later she remains healthy and able to do her housework and exercises. The lesson here is that a tight valve (mitral stenosis) and heart failure can mimic other causes of lung congestion and can produce symptoms that resemble asthma and acute bronchitis.

B. Mitral Regurgitation

A heart valve may be diseased in such a manner that it does not close tightly during contraction of the left ventricle. When the mitral valve is not shut tight, blood leaks or regurgitates from the ventricle back into the left atrium, thus the leaking valve is called mitral regurgitation. These patients tolerate the leak for many years and, in a few, the left ventricle as well as the left atrium can become enlarged; shortness of breath occurs and surgery to replace the valve may be necessary. Patients can tolerate the lesions for about 5–30 years, depending on tolerance to bothersome symptoms. In some patients heart failure occurs, and they require drug treatment and surgery. Surgery should be done before heart failure develops. The timing for surgery is very difficult to gauge in some cases. In some patients the valve may be suitable for surgical repair and this avoids the use of a prosthetic heart valve and anticoagulation.

C. Aortic Stenosis

I. Causes and Natural History

Aortic stenosis is usually due to previous rheumatic fever or calcification in the elderly. In young patients a congenital bicuspid valve may become calcified, hardened, and narrowed over 10–50 years. Rheumatic aortic stenosis is still uncommon in developed countries, but it is the most

common cause of aortic stenosis in developing countries such as Asia, Africa, the Middle East, and Latin America.

Diagnosis before age 50 is typical of congenital aortic stenosis. In patients above age 70 calcific aortic stenosis due to degenerative calcification is common and severe stenosis develops in up to 10% of these individuals. This lesion is now the most common reason for aortic valve replacement in the United States. A recent clinical trial indicates that the use of a statin decreases calcification and the degree of stenosis, and it is highly recommended therapy prior to development of moderate aortic stenosis.

2. Symptoms

The patient may remain relatively asymptomatic until severe stenosis develops. Shortness of breath is usually the first symptom. In aortic stenosis, the aortic valve (see Fig. 1) is tight and obstructs the flow of blood from the left ventricle into the aorta with less blood reaching the head. Symptoms such as dizziness, fainting (syncope), shortness of breath, and chest pain (angina) may occur. The left ventricle tries to overcome the obstruction by pumping more forcefully, and over the years the muscle becomes thick and enlarges and finally fails to pump efficiently.

3. Physical Signs

A systolic crescendo–decrescendo murmur is best heard at the left sternal border, the second right interspace, or occasionally at the apex with radiation to the neck. Severe stenosis is indicated by a murmur that is louder and peaks late in systole. A palpable thrill may result and this is usually a thrusting apex beat caused by left ventricular hypertrophy. The carotid pulse in patients below age 65 shows a typical delayed upstroke.

4. Investigations

The severity of aortic stenosis can be determined by continuous wave Doppler echocardiography. This technique agrees with the data obtained at catheterization in up to 90% of cases. Mild aortic stenosis is indicated by a mean aortic valve pressure gradient of less than 20 mmHg and a valve area greater than 1.5 cm². Moderate stenosis is indicated by a mean pressure gradient of 21–39 mmHg and a valve area greater than 0.9–1.4 cm². Severe aortic stenosis is indicated by a pressure gradient greater than 40 mmHg (40–120 mmHg) and a valve area less than 0.75 cm².

5. Therapy

Severe shortness of breath, chest pains, fainting spells, enlargement of the left ventricle, or heart failure are

indications for surgery. During surgery the diseased valve is removed and an aortic valve prosthesis is usually inserted. This is extensive surgery and is done only when justifiable. Any patient over age 45 may have concomitant coronary heart disease and may require valve replacement as well as coronary artery bypass graft.

D. Aortic Regurgitation

1. Natural History and Symptoms

In this condition the aortic valve remains widely open when it should be tightly closed, therefore, blood regurgitates or leaks from the aorta backward into the left ventricle (see Fig. 1). The main symptom is shortness of breath. The left ventricle, however, tolerates regurgitant volume overload and compensates adequately for several years. An asymptomatic 10- to 20-year period is common. Many patients with a moderate degree of aortic regurgitation deny shortness of breath on walking 2–5 miles or climbing three flights of stairs. Complaints of shortness of breath on exertion, fatigue, palpitations, and dizziness are generally associated with moderate-to-severe regurgitation or severe regurgitation of recent onset.

2. Diagnostic Physical Signs

The radial and brachial pulses have a typical collapsing-bounding character in aortic regurgitation. The blood pressure shows a wide pulse pressure with diastolic pressures often less than 50 mmHg. A typical high-pitched blowing decrescendo murmur begins immediately after the second heart sound. It is unmistakable to the trained ear and is best heard with the diaphragm of the stethoscope pressed firmly against the chest with the patient leaning forward and the breath held in deep expiration.

3. Investigations

Color flow Doppler echocardiography provides quantification of aortic regurgitation and dimensions of the left ventricle. Marked changes or rate of change at 6-monthly assessments should guide the timing for surgery in symptomatic patients with moderate-to-severe regurgitation. Relatively asymptomatic patients with moderate-to-severe regurgitation are not offered surgery because of the high risks involved.

4. Therapy

The left ventricle has more work to do with aortic regurgitation and over several years dilates and enlarges. Surgery is not often required because the left ventricle

cope with the extra work for many years and drugs such as nifedipine appear beneficial in delaying surgery in patients with a moderate degree of stenosis. Leaking valves impose less work on the heart than obstructed valves. When heart failure occurs due to a leaking valve, digoxin and diuretics are helpful as well as vasodilators such as ACE inhibitors. Surgery is required to replace the valve before heart failure occurs. The timing for surgery can be very difficult to estimate and surgical intervention is not without risks.

Prosthetic heart valve surgery is a major undertaking and careful assessment by a cardiology team is necessary. Post surgery, the patient may need to take anticoagulants to prevent clotting of the valve. Warfarin is given if a mechanical valve is used or if atrial fibrillation is present. A bioprosthesis is advised in patients over age 65, and no blood thinners are required with these valves.

E. Mitral Valve Prolapse

This is a common disease. The mitral valve leaflets become stretched and floppy with redundant folds. The valve is damaged by a degenerative myxomatous process.

1. Physical Signs

When a patient has mitral valve prolapse, the doctor hears the valves flapping like a sail in a crisp wind. The noise heard is typical and is called a click and murmur. The click can be similar to a loud tick of a clock or at times like a musical sound. The systolic murmur is typically late in timing.

This condition is somewhat more common in females, and about 5% of individuals over age 25 have this click and murmur, which is produced by the mitral valve. Middle-aged men, however, develop a more complicated valve disturbance.

2. Symptoms and Natural History

Mitral valve prolapse is a benign condition; less than 1 in every 100 cases may have a problem. But many people become anxious and nervous about this problem as it has become exaggerated by physicians. Panic attacks may occur. A few individuals may have palpitations consisting chiefly of premature beats that rarely cause fainting spells. Beta-blockers are very useful in this condition to relieve bothersome palpitations and faint-like episodes. Chest pain occurs in a few, but the condition is not related to coronary heart disease and there is no relation between the disease and heart attacks. In less than 1 in 100 cases, the valve leaflet may weaken or get a redundant

fold and cause regurgitation of blood. In such patients mild and sometimes severe mitral regurgitation may occur.

In the western world, severe mitral prolapse is the most common reason for repair or replacement of the mitral valve in men and women. In third world countries, rheumatic fever remains the most common cause for mitral valve replacement.

Infection of the valve causing bacterial endocarditis and further damage may occur, particularly if a murmur is present. Thus, prophylaxis with antibiotics is advisable before dental work and surgical procedures, otherwise the patient, who can live to over age 80, may have an abrupt shortening of life (see the chapter Endocarditis).

V. PROSTHETIC VALVE CHOICE

Problems exist with all types of valve prosthesis; none is ideal. More than one million valves have been implanted worldwide.

A. Mechanical Prostheses

Commonly used mechanical valves are shown in Fig. 2. The bileaflet and floating disk designs are most popular in North America. Mechanical valves are the first choice in patients less than age 70 because of they last longer. When a mechanical valve is used anticoagulation with warfarin is necessary to prevent thromboembolism. In most patients with atrial fibrillation the valve implant chosen is a mechanical one because anticoagulation is indicated in both instances.

B. Tissue Prostheses

Bioprosthetic valves are the first choice in patients over age 70 because these valves are expected to only last from 15 to 20 years. Anticoagulation is not required with bioprosthetic valves except when anticoagulation is necessary for the management of atrial fibrillation to prevent stroke. Xenograft tissue valves are shown in Fig. 3. The vast majority of biologic valves (bioprostheses) implanted since 1960 are stented xenografts. Several manufacturers have recently introduced stentless xenografts. These grafts were designed to improve hemodynamics by elimination of the bulky stent and sewing ring. Currently it is unclear whether the durability of stentless xenografts is superior to that of stented valves. The implantation of stentless grafts is much more complex than stented valves; the necessary subcoronary technique has a potential

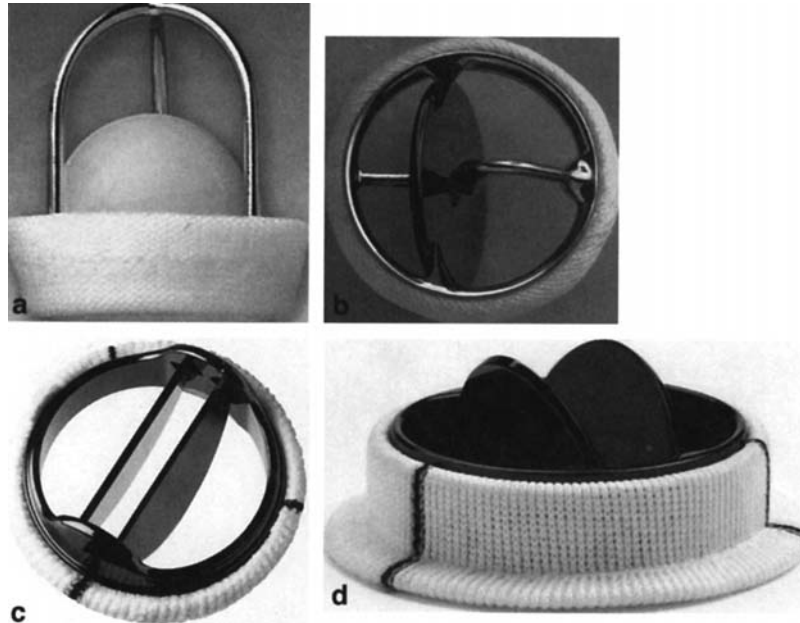

FIGURE 2 Mechanical prostheses. (A) The Starr-Edwards ball-in-cage prosthesis was popular for many years and demonstrated excellent durability (photo courtesy of Edwards Lifesciences, LLC). (B) The Hall-Medtronic single tilting disc prosthesis is the dominant single-disc valve in the United States (photo courtesy of Medtronic Corp.). (C) The St. Jude bileaflet design is the most popular mechanical prosthesis in this country at the current time (image is provided courtesy of St. Jude Medical, Inc. All rights reserved). (D) The Carbomedics “top-hat” bileaflet design is designed to permit supra-annular implantation (photo courtesy of Carbomedics, Inc.).

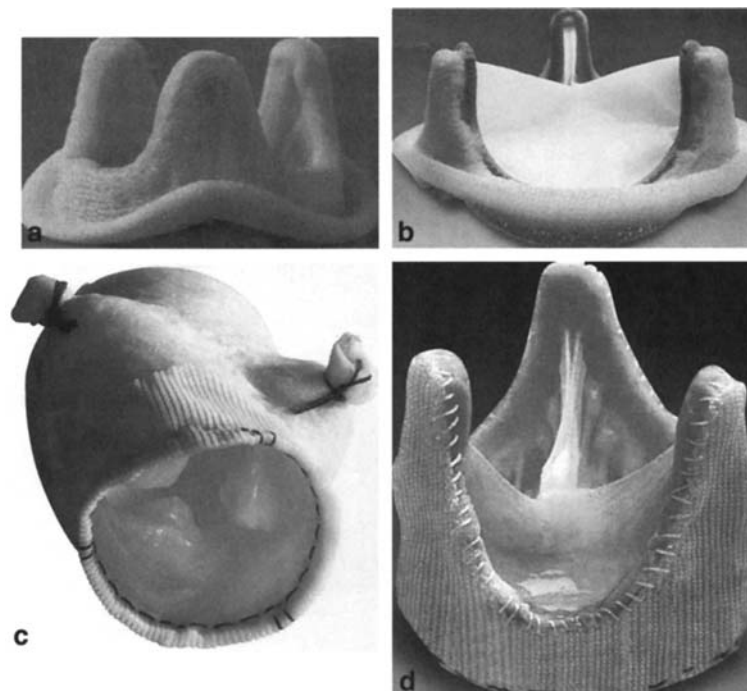

FIGURE 3 Xenograft tissue valves. (A) The Medtronic Hancock Bioprosthesis is constructed from a porcine aortic valve (photo courtesy of Medtronic Corp.). (B) The Baxter Perimount (Registered trademark, Edwards LLC) valve was engineered to optimize hemodynamics and durability with leaflets made from bovine pericardium (photo courtesy of Edwards LLC). (C) The Medtronic Freestyle stentless xenograft may be implanted as a free-standing root replacement or using a subcoronary technique (photo courtesy of Medtronic Corp.). (D) The St. Jude Toronto SPV (registered trademark of St. Jude Medical, Inc.) stentless xenograft must be implanted using the subcoronary technique (photo courtesy of St. Jude Medical Inc.).

disadvantage of predisposing the patient to aortic regurgitation. Perhaps because of these complexities and the as yet unproven advantage, stentless valves continue to search for their appropriate place in valve replacement surgery.

Homografts have better long-term performance than stented xenografts; however, they still have limited durability. Their use is hindered by limited availability and necessity for liquid glycogen storage. Their implantation is also more complex than that for stented valves and the surgical technique is complicated similar to implantation of stented xenografts. They do possess remarkable flexibility and are useful to accommodate for complex root pathology, particularly following bacterial endocarditis.

BIBLIOGRAPHY

- Biancianiello, T. et al. Innocent murmurs. *Circulation*, 111:e20–e22, 2005.
- Enriquez-Sarano, M., Tajik, A. J. et al. Aortic regurgitation. *N. Engl. J. Med.*, 351:1539–1546, 2004.
- Fish, R. D. et al. Percutaneous heart valve replacement: Enthusiasm tempered. *Circulation*, [Editorial] 110:1876–1878, 2004.
- Khan, M. Gabriel. In *Heart Disease Diagnosis and Therapy: Valvular heart disease*, second edition. Humana press, New Jersey, 2005.
- Khan, M. Gabriel. Evaluation and treatment of patients with murmurs. In *On Call Cardiology*, second edition. W. B. Saunders, Philadelphia, 2001.
- Otto, C. M., Salerno, C. T. et al. Timing of surgery in asymptomatic mitral regurgitation. *N. Engl. J. Med.*, [Editorial] 352:928–929, 2005.
- Rahimtoola, S. H. et al. The year in valvular heart disease. *J. Am. Coll. Cardiol.*, 45:111–122, 2005.
- Sundt, T. M. Current options for replacing the aortic valve in adults. *J. Am. Coll. Cardiol. ACC Curr. Rev.*, January/February, 78–82, 2002.

Ventricular Fibrillation

- I. Clinical Features
- II. Genesis and Causes
- III. Management

GLOSSARY

ejection fraction the fraction of blood ejected from the heart into the arteries, normally this ranges from 60 to 75%; a low ejection fraction is less than 40%; often used as a marker of ventricular contractility.

myocardial infarction death of an area of heart muscle due to blockage of a coronary artery by blood clot and atheroma; medical term for a heart attack or coronary thrombosis.

platelet aggregation clumping together of small particles in the blood; platelets increase clot formation.

Wolff-Parkinson-White syndrome characterized by premature excitation of the ventricles due to an anomalous conduction bypass tract between the atria and ventricles; often leads to rapid heart rates.

I. CLINICAL FEATURES

Ventricular fibrillation (VF) results in sudden faintness and loss of consciousness, cessation of respiration, and death. During VF the heart muscle does not contract but “quivers”; therefore, there is no heartbeat (cardiac arrest) and no blood is pumped out of the heart. Death occurs within minutes if the abnormal heart rhythm is not corrected. Ventricular fibrillation requires electrical counter-shock within three minutes to change this life-threatening rhythm to normal heartbeats. Cardiopulmonary resuscitation (CPR) must be instituted immediately to maintain a blood supply to the brain until a defibrillator is available, hopefully within a few minutes. Note that in atrial fibrillation, the atrium fibrillates but the ventricles contract normally although faster than normal. This condition is usually not life-threatening and is easily controlled with the digoxin or a beta-blocker and anticoagulants.

More than 75% of patients resuscitated from out-of-hospital cardiac arrest have VF. Occasionally VF is preceded by ventricular tachycardia (VT). Figure 1 shows the bizarre, irregular undulations of varying contour and amplitude. Distinct QRS complexes, ST segments, and T waves are absent and the irregular undulating baseline is diagnostic of VF.

II. GENESIS AND CAUSES

A. Genesis

The onset of VF is believed to involve the disintegration of a single spiral wave into many self-perpetuating waves. It appears that the breakup of spiral waves is precipitated by oscillations of action potential duration that are of sufficiently large amplitude to cause conduction block along the spiral wavefront.

Intracellular calcium accumulation, the action of free radicals, metabolic alterations, and autonomic modulation are some of the factors that are associated with the development of VF during severe ischemia.

B. Causes

I. Coronary Artery Disease

VF is observed in individuals with coronary artery disease and as a terminal event. VT commonly precedes the onset of VF but often there are no consistent premonitory warning signals observed. Approximately 75% of patients resuscitated from VF have significant coronary artery disease and acute myocardial infarction develops in approximately 30%. Acute coronary artery thrombosis has been noted in up to 70% of patients with VF. Individuals resuscitated from VF in whom acute myocardial infarction does not develop have an increased rate for sudden cardiac death or VF. Predictors of death for patients resuscitated from VF include a reduced

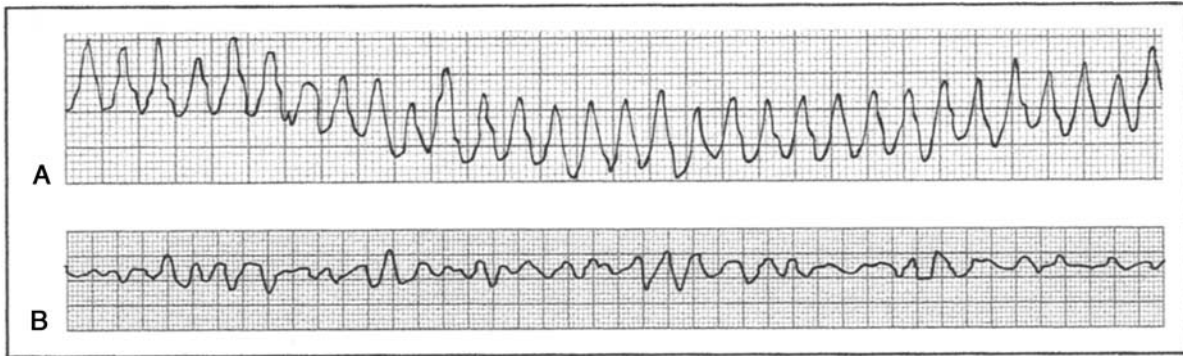

FIGURE 1 Ventricular flutter and ventricular fibrillation. (A) The sine wave appearance of the complexes occurring at a rate of 300 beats per minute is characteristic of ventricular flutter. (B) The irregular undulating baseline typifies ventricular fibrillation.

ejection fraction, congestive heart failure, history of myocardial infarction, and the presence of ventricular arrhythmias.

VF causing sudden cardiac death occurs most frequently in the early morning and appears to be related to increased platelet aggregation. Sudden death from VF occurs more often in winter months and appears to be related to the sudden exposure to cold temperatures which influence platelet aggregation.

VF can occur during antiarrhythmic drug therapy or after electrical shock is applied during cardioversion. It is also observed during competitive ventricular pacing to terminate VT. Sudden death in cardiomyopathy and dilated cardiomyopathy is often precipitated by VF.

C. Other Causes

Other disturbances associated with VF include Brugada syndrome and arrhythmogenic right ventricular dysplasia. Stokes-Adams attacks are caused by complete heart block that culminates in VF. Rapid ventricular rates such as in Wolff-Parkinson-White syndrome, hypoxia, and rarely atrial fibrillation can be associated with it as well. Also, improperly grounded equipment and electrocution during an electrical storm can cause VF.

III. MANAGEMENT

Immediate, non-synchronized DC electrical shock using 350–400 J should be rapidly applied without attempting to obtain an ECG or palpating pulses. VF rarely converts spontaneously to normal rhythm and shock must be applied immediately. CPR is used only until the equipment is ready and the shock usually terminates VF. This may cause the asystolic heart to beat and time should not be wasted with CPR if defibrillation can be accomplished rapidly.

If a defibrillator is used within 60 seconds significant metabolic acidosis does not occur and sodium bicarbonate should be withheld. Intravenous calcium is administered to treat hypocalcemia, hyperkalemia, or calcium antagonist overdose.

BIBLIOGRAPHY

- Olgin, J. E., and Zipes, D. P. Specific arrhythmia: Diagnosis and treatment. In *Heart Disease*, sixth edition. E. Braunwald, D. P. Zipes, and P. Libby, eds. W. B. Saunders, Philadelphia, 2001.
- Witkowski, F. X., Leon, L. J., Penkoske, P. A. et al. Spatiotemporal evolution of ventricular fibrillation. *Nature*, 392:78–82, 1998.
- Wenzel, V., Krismer, A. C., Arntz, H. R. et al. For the European Resuscitation Council Vasopressor during Cardiopulmonary Resuscitation Study Group A Comparison of Vasopressin and Epinephrine for Out-of-Hospital Cardiopulmonary Resuscitation. *N. Engl. J. Med.*, 350:105–113, 2004.

Women and Heart Disease

- I. Relevant Statistics and Perspectives
- II. Recognized Differences in Women and Men
- III. Hormone Therapy
- IV. Pregnancy and Heart Disease

GLOSSARY

- aneurysm** a ballooning of the wall of an artery or heart muscle caused by severe weakening of the walls of the artery or the heart muscle.
- arrhythmia** general term for on the irregularity or rapidity of the heartbeat, an abnormal heart rhythm.
- atheroma** same as atherosclerosis, raised plaques filled with cholesterol, calcium, and other substances on the inner wall of arteries that obstruct the lumen and the flow blood; the plaque of atheroma hardens the artery, hence the term atherosclerosis (sclerosis = hardening).
- heart failure** failure of the heart to pump sufficient blood from the chambers into the aorta; inadequate supply of blood reaches organs and tissues.
- myocardial infarction** death of an area of heart muscle due to blockage of a coronary artery by blood clot and atheroma; medical term for a heart attack or coronary thrombosis.

I. RELEVANT STATISTICS AND PERSPECTIVES

There is a false notion that cardiovascular disease is more common in men than in women. After age 65, one in three women have some form of cardiovascular disease. More than 350,000 women die of a heart attack and more than 120,000 die of a stroke in the United States each year. This situation is occurring because of the relatively large population of older women who are at high risk for cardiovascular events. The National Center for Health Statistics indicates that for the 12 months ending in August 1994, deaths from cardiovascular disease in the United

States were 944,280 and more women died of cardiovascular disease than men and women accounted for more than 490,000 of these deaths. The 1990 statistics revealed that of all cardiovascular deaths, 56% occurred in women and 44% in men. The 1992 statistics indicate that 52% (479,000) occurred in women and 48% (444,000) occurred in men; with 246,000 deaths from all forms of cancer (43,100 breast cancer and 55,900 lung cancer).

Cardiovascular disease is a much more common cause of death and disability in women than all forms of cancer, pneumonia, and AIDS. Women incorrectly perceive their risk of cancer of the breast and uterus as much greater than that of heart disease or stroke. More than twice as many women die of cardiovascular disease than all forms of cancer in United States.

Fortunately, most women are protected from the risk of heart attack up to age 48 because of their hormonal status. It is extremely rare for a normal menstruating woman to have a heart attack prior to age 47 except in those who have blood cholesterol at levels greater than 260 mg (6.5 mmol) or in diabetics, whereas many men die from myocardial infarction between age 35 and 48. The incidence of heart attack in men and women at age 35, 40, 50, 65, 70, and 75 is about 100:1, 20:1, 10:1, 5:2, 5:4, 1:1. Because more men age 35–65 than women have heart attacks and angina, there are more clinical studies done on men using drugs and undergoing coronary bypass surgery and angioplasty. Women believe they are not treated equally by the medical profession particularly in the area of heart disease. Women are not excluded from studies, the majority fortunately do not manifest coronary artery disease until after age 70 and long-term trials for sound reasons often include patients up to the age 70.

Women believe that there is some bias attached to the treatment of men versus women with heart problems. Some doctors are proclaiming that women with heart disease have different symptoms from men and respond differently to drugs, angioplasty, and bypass surgery. This assumption is incorrect. Because an insufficient amount of women age 35–65 were available to be included in the

studies, information on women and heart disease is deficient. Patients age 71–80 are not usually entered into long-term follow-up studies. It is obvious that there are more 75- to 85-year-old women with heart attacks than men as the population of elderly women is increasing relative to men.

Symptoms of a genuine heart attack are not significantly different in women and men. Some women suffer with shortness of breath or nausea instead of pain during a heart attack, but so do a few men. Diagnosis of a heart attack is similar in women and men. An ECG records the same information for both.

The medical treatment for heart attack is virtually the same for both women and men and the response is the same. All blood pressure lowering medications work equally well in women and men to prevent stroke or heart failure. Bypass surgery and angioplasty in the elderly carry a greater risk, and the results of angioplasty appear to be less impressive in women. Women age 60–70 who need bypass surgery do just as well as men. Complications of bypass surgery are said to be slightly higher in women, but the women are older than age 75. There are no studies done to compare 71- and 81-year-old men and women undergoing bypass surgery and angioplasty. Bypass surgery is done more often in men at a younger age, because this treatment is performed to relieve angina. Angina interferes with lifestyle, particularly the ability to work, between age 40 and 65. This is an age at which women are less subjected to disabling angina.

II. RECOGNIZED DIFFERENCES IN WOMEN AND MEN

Apart from heart disease in pregnancy and coronary artery disease there is very little difference between the incidence, symptoms, signs, and therapy for various heart and other cardiovascular diseases in men and women.

A. Atypical Chest Pain versus Angina

There is greater difficulty diagnosing nonspecific symptoms that are angina-like between men and women. There is no difficulty with the diagnosis of acute myocardial infarction, heart failure, arrhythmias, pericarditis, valvular heart disease, or stroke. Women do present at age 45–65 with nonspecific chest pain, angina-like symptoms, chest wall pain, pain caused by gastroesophageal reflux (GER), esophageal spasm, and other noncardiac causes of chest pain. A few of these patients have genuine coronary artery disease. Thus, caution is required because women may

have atypical chest discomfort (not the typical chest pain of angina) when they have angina caused by obstructive atheromatous coronary artery disease (see the chapter Angina).

Symptoms of angina pectoris are recurrent pain or discomfort of short duration arising in the chest, throat, jaw, or arms caused by severe but temporary lack of blood and oxygen. This is precipitated by a particular exertional activity and is quickly relieved within minutes of cessation of the precipitating activity. Some women present with typical angina but some describe the pain as a peculiar feeling of unpleasant yet mild discomfort, and a knot or bothersome discomfort in the neck or ache in the left arm. If the discomfort is associated with brisk walking or walking up an incline and relieved within a few minutes by stopping the walk, then angina caused by coronary artery disease should be strongly suspected.

I. Exercise Testing and Nuclear Imaging

There are many reasons why exercise treadmill testing with conventional ST segment analysis is believed to provide less accurate diagnoses for coronary artery disease in women than in men. Some of these differences may be explained by differences in the disease prevalence and severity of the disease from age 40 to 70. Women have a lower prevalence and severity of the disease prior to age 70 when most exercise testing is performed. Women younger than age 65 have a low prevalence of multivessel disease; single-vessel disease is more common in women and multivessel and left main disease is more common in men at this age. Obviously, patients with more severe disease have a higher incidence of abnormal exercise test results. Compared with men of the same age (50–70), women are less likely to achieve more than 9 minutes of exercise using the Bruce protocol and achieving an adequate heart rate response to exercise. Women with coronary artery disease usually present at a later age than men and after age 70 have a greater number of comorbidities that significantly reduce the ability to perform an adequate exercise stress test. Nonetheless, a negative test result in a woman or man who has completed more than 9 minutes of the Bruce protocol and achieved more than 85% maximal heart rate is a powerful tool for excluding the presence of significant ischemia caused by atherothrombotic coronary artery disease.

Several meta-analyses of treadmill testing indicate differences between men and women, but these reports are misleading. The false-negative rate for women is low (12–22%) and is comparable to that for men (12–40%). Thus treadmill testing that achieves more than 85%

maximal heart rate reliably excludes the presence of significant coronary artery disease in women with negative results just like it does in men. The treadmill results in 580 women from the CASS trial showed a 3% false-positive rate for men and a 14% rate for women. When the same population was matched for differences in demographics and clinical characteristics, however, the differences in the false-positive rates were no longer detected.

The lower sensitivity of exercise testing in women compared with men adjusted for age and the presence of diabetes appears to relate to the finding of less ST-segment depression in women compared with men. The differences may be related in part to lower exercise tolerance in women, which causes lower maximal heart rates and systolic blood pressures at peak exercise. Also, studies have indicated that estrogen affects coronary vasomotor tone and may play a role in alteration of ST-T wave changes.

There is little doubt that the sensitivity and specificity of treadmill exercise testing for the detection of coronary artery disease in women are improved when combined with myocardial perfusion imaging. Yet the lack of effort tolerance to achieve an adequate heart rate response and the presence of comorbidities in women older than age 70 that limit exercise duration add limitations to these expensive tests. Adenosine or dipyridamole is used in individuals who are unable to complete an exercise stress test, but good sensitivity and specificity are lacking.

Stress echocardiography is claimed by some to be more accurate than exercise testing in women suspected of coronary artery disease, but these small studies do not include nuclear imaging.

B. Innovative Technology

Clearly technologic advances are necessary to provide other methods of noninvasive testing currently used for detecting the presence of atheromatous coronary artery disease. Currently used investigative methods that have many drawbacks and are unsatisfactory diagnostic tools include treadmill exercise testing, nuclear imaging, treadmill stress testing combined with nuclear imaging, adenosine or dipyridamole cardiac nuclear imaging, echocardiography, Stress echocardiography, PET scan, and electron beam CT scan for coronary calcification (see the chapter Tests for heart diseases).

C. Acute Myocardial Infarction

Women appear to experience more severe consequences of myocardial infarction than men. In every age group women with coronary artery disease have a higher risk of

death from coronary events than men. Older women are twice as likely as older men to die within weeks after a heart attack. In the first year after a heart attack 27% of men and 44% of women are expected to die, but this accounting is not age specific. The risk of death is equal in women and men with ejection fractions less than 35%. Sudden cardiac death is reportedly more common in men than in women.

Ventricular septal and free wall rupture following acute myocardial infarction occur more often in women than in men. From age 75 to 85, women may have a slightly higher risk of bleeding with thrombolytic therapy and doctors need to reduce the dose of thrombolytic drugs to match the age and weight of women.

D. Dyslipidemia

Generally, levels of low-density lipoprotein (LDL) cholesterol are lower in women than in men until the age of 50, after which LDL levels increase. An exception to this finding is in patients with genetic familial hypercholesterolemia and in diabetics. High-density lipoprotein (HDL) cholesterol levels are approximately 10 mg/dl (0.3 mmol/L) higher in women than in men of all ages. The combination of a lower LDL cholesterol and slightly higher HDL cholesterol from age 35 to 55 in women compared with men is believed to account for the lower prevalence of coronary artery disease and coronary events in women compared with men from age 35 to 65. Atherothrombotic disease progresses from age 55 in women and culminates in serious events that include angina, acute myocardial infarction, and heart failure mainly from age 70 onward.

The use of oral contraceptive pills has been associated with increased risk of stroke, myocardial infarction, and thromboembolism (see the chapter Contraception and Cardiovascular Disease).

III. HORMONE THERAPY

A. Premenopausal Protection

Atherothrombotic cardiac disease is rare in women aged 30–50 before menopause when compared with men. This protection from atherothrombotic disease is due to very high estrogen levels that maintain LDL cholesterol at very low levels and increase HDL levels considerably.

Atherothrombotic coronary artery disease, however, occurs in women age 35–50 who have undergone surgical or chemical oophorectomy, a condition in which there is a documented accelerated rate of atherosclerosis. Coronary

artery disease also occurs in women who have diabetes or genetic familiar hypercholesterolemia, and progression of disease is increased in smokers and with the presence of hypertension.

After menopause estrogen levels fall drastically, and this results in an increase in LDL cholesterol levels and a mild decrease in HDL levels. Because of this change atherosclerotic disease of the coronary arteries develops gradually from age 50 to 70 and culminates in angina or myocardial infarction mainly during age 65–85. This progressive atherothrombotic disease is not prevented, however, by exogenous hormone replacement (HRT). The findings of recent randomized clinical trials show no beneficial cardiac effects of HRT. These findings are not surprising because HRT causes only a modest 11% reduction in LDL cholesterol and only a 10% increase in HDL cholesterol. This is a change in lipid levels that is unlikely to accomplish regression of disease or cause a decrease in mortality. A 10% increase in HDL cholesterol has been overrated as a measure of cardioprotection, and is unlikely to ameliorate the progression of atherothrombotic disease when this is already present in women at age 60 and beyond. The statins are capable of reducing LDL cholesterol 20–40% and have shown decreased cardiac mortality in several randomized clinical trials. In The Lipid Research Clinic trial cholestyramine caused about a 13% reduction in total cholesterol and showed no decrease in total or cardiac mortality. A total cholesterol decrease of more than 33% sustained for several years appears to be necessary for the prevention of atherothrombotic coronary disease and its complications. The premenopausal hormonal status in women does not protect from atherothrombotic stroke, however. The reason why a woman's premenopausal hormonal status protects her from coronary artery disease and not cerebral artery disease remains unclear, and has received little attention in various publications.

B. Clinical Studies

I. Heart and Estrogen/Progestin Replacement Study

The Heart and Estrogen/Progestin Replacement Study (HERS) evaluated 2763 women with known coronary disease who were postmenopausal and had an intact uterus. After a 4-year follow up HRT resulted in an 11% reduction in LDL cholesterol and a 10% increase in HDL cholesterol, but the overall rate of coronary artery disease events was not decreased. There was a statistically significant time trend with more coronary artery disease events occurring in the HRT group at one year and fewer events in years four to five. Most important, thromboembolic

events were increased by HRT. There was no significant effect on the risk of stroke.

2. Estrogen Replacement and Atherosclerosis Trial

The Estrogen Replacement and Atherosclerosis (ERA) trial demonstrated that estrogen replacement with or without progestin did not significantly improve the angiographic progression of atherosclerotic disease in postmenopausal women who had known coronary artery disease when compared with placebo.

3. Woman's Health Initiative Study

The Women's Health Initiative (WHI) study randomly assigned 16,608 postmenopausal women 50–79 years of age with an intact uterus to estrogen 0.625 mg plus medroxyprogesterone 2.5 mg or placebo. After three years' follow up HRT did not have a clinically meaningful effect on health-related quality of life issues such as general health, vitality, mental health, depressive symptoms, or sexual satisfaction. Treatment resulted in a small benefit in terms of sleep disturbance, but no benefit in terms of other quality of life outcomes.

After a mean follow up of 5.2 years, the data and safety monitoring board recommended terminating the estrogen plus progestin trial because the overall risks exceeded the benefits.

It was concluded that estrogen plus progestin does not confer cardiac protection and may increase the risk of coronary artery disease among generally healthy postmenopausal women. This treatment should not be prescribed for the prevention of cardiovascular disease.

Other studies have recently confirmed an increased risk of breast cancer with the use of HRT and it is no longer recommended for the primary and secondary prevention of coronary artery disease or prevention of stroke. The WHI randomized trial of conjugated equine estrogen alone, in postmenopausal women with hysterectomy, showed an increase in stroke but no increase in coronary disease or breast cancer. The follow up, however, was only 6.8 years and caution is required.

IV. PREGNANCY AND HEART DISEASE

Pregnancy imposes an internal workload on the cardiovascular system similar to that of endurance exercise. The placenta and fetus require a huge blood supply that must be pumped through a large circuit of blood vessels,

and the altered vasculature is similar to that found with a large arteriovenous fistula. Redistribution of the greatly expanded blood volume occurs and an increase in cardiac output that begins around the fifth week of conception peaks between the 20th to 24th week. A resultant hyperdynamic state occurs with increased heart rate and a bounding pulse that has a collapsing character because of a fall in diastolic pressure and widened pulse pressure.

Fortunately serious cardiovascular disturbances rarely occur during pregnancy and mainly in women who have underlying heart or hypertensive disease. The main disorders of concern include accelerated hypertension caused by preeclampsia, life-threatening pulmonary edema, or heart failure in patients with tight mitral stenosis or other severe valvular disorder, arrhythmias that may be bothersome, pulmonary hypertension, cerebrovascular accident, aortic dissection in those with Marfan syndrome, and the rare peripartum cardiomyopathy. Maternal heart disease occurs in approximately 2% of pregnancies in the western world.

A. Hypertension

Normally blood volume increases by 130–150% of non-pregnancy values and cardiac output increases by up to 50% commencing soon after conception. There is a marked reduction in peripheral vascular resistance caused by widespread systemic arterial vasodilatation that occurs as a result of increased levels of gestational hormones including progesterone, circulating prostaglandins, and atrial natriuretic factor. Thus, blood pressure decreases slightly despite the increased cardiac output. This reduction in systemic vascular resistance allows the heart to pump the increased volume of blood against less resistance with less work and oxygen requirement.

A diagnosis of chronic hypertension is based on the confirmed existence of hypertension before conception and particularly prior to the 20th week of pregnancy; at which stage a blood pressure greater than 140/90 mmHg is considered abnormal. Fortunately a mild or moderate degree of hypertension causes minimal complications to mother or fetus even when drug therapy is withheld. Superimposed preeclampsia occurs in about 6% of pregnant women regardless of blood pressure control.

I. Clinical Study: Mabie et al.

Treatment with methyldopa with added hydrochlorothiazide was administered to 82 women and no therapy was given to 82 women with chronic hypertension seen before the 20th week. Triple therapy with added propranolol was

necessary in five women. There was the difference in perinatal mortality, but there was an increase in fetal growth restriction in the treatment group.

2. Clinical Study: Sibai et al.

This study randomized 263 women with mild-to-moderate hypertension to methyldopa, labetalol, or no treatment at 6–13 weeks to achieve a blood pressure of less than 140/90 mmHg. There was no significant difference in gestational age at delivery, premature delivery, mean birth weight, superimposed preeclampsia, placental abruption, or perinatal mortality. If preeclampsia develops and its complications occur, drug therapy is necessary for control of blood pressure.

3. Drug Therapy

Methyldopa at a dose of 500–1500 mg daily is the most widely used agent and its relative safety has been recognized over the past 40 years. During the past decade, however, many obstetricians have replaced methyldopa with labetalol or atenolol, because methyldopa causes depression in up to 25% of patients, sedation, postural hypotension, and a positive direct Coombs test.

Atenolol 25–75 mg once daily is a relatively safe and effective agent for the control of mild-to-moderate hypertension from the 16th week to 1 week prior to labor. Labetalol is reported in many publications to be safe, but this author cautions that fatal or nonfatal hepatic necrosis has been reported in nonpregnant hypertensives. Also, a lupus-like illness, a lichenoid rash, abnormal liver function tests, and postural hypotension not observed with pure beta-adrenergic blocking agents may occur. Labetalol is a most useful agent for short-term use such as for hypertensive emergencies, accelerated hypertension, and emergencies in preeclampsia and can be used prior to delivery and during delivery if required.

Hydralazine, a pure arteriolar vasodilator, has been used extensively for the acute control of severe hypertension in the third trimester and predelivery. Its chronic use is not recommended because the drug causes sodium and water retention that may necessitate the use of a diuretic. For hypertensive crisis a 5- to 10-mg bolus is injected intravenously. It is given orally 25 mg twice daily increasing to 100 mg daily used in combination with other agents for one to two weeks if needed for emergency control of hypertension associated with preeclampsia.

Diuretics are not generally recommended because fetal outcome is usually worse in women with preeclampsia

who fail to expand the plasma volume that is reduced by diuretics.

Nifedipine has been used effectively for short-term emergency control of accelerated hypertension. Caution is required because the drug occasionally causes a precipitous fall in blood pressure, and this is more likely to occur if magnesium sulfate is added concomitantly. Nimodipine has special vasodilator effects on human cerebral vessels, and it has been used effectively to control blood pressure in patients with subarachnoid hemorrhage. This drug may prove useful in treating severe hypertension of preeclampsia and for the prevention of seizures in eclampsia, which are associated with cerebral vasospasm and cerebral ischemia.

B. Valvular Heart Disease

I. Mitral Stenosis

In mitral stenosis left atrial pressure rises and diastolic blood flow through the tight mitral valve is slowed. In addition, cardiac output and intravascular volume reach a peak by weeks 20–24. A 50% increase in cardiac output during pregnancy may cause a marked increase in the pressure gradient across the valve. Patients with moderate-to-severe mitral stenosis and a mitral valve area less than 1.2 cm² are at increased risk of dramatic and at times fatal pulmonary edema. The heart rate increases an average of 10 beats per minute. Increases in heart rates cause a shortened ventricular filling time and a marked increase in left atrial pressure. Sinus tachycardia, thus, may precipitate pulmonary edema which may be fatal. Reduction of resting heart rate from a mean of 90 to 75 beats per minute is associated with a marked improvement in left ventricular filling and prevention or amelioration of pulmonary edema. Also, with atrial fibrillation and a fast ventricular response beta-blockers are useful when trying to achieve a ventricular rate less than 80 beats per minute. Digoxin does not reduce the heart rate sufficiently with atrial fibrillation. If pulmonary edema develops diuretics are added to beta-blocker therapy followed at the opportune time by valvuloplasty or surgery to relieve mitral stenosis. A valve area of less than 1 cm² or valve area corrected for body surface area (valve area index <1 cm²/m²) indicates severe mitral stenosis.

Regurgitant valve lesions are better tolerated than stenotic lesions. Symptoms and signs worsen in patients who were symptomatic before pregnancy. Patients who are asymptomatic prior to pregnancy usually have uneventful pregnancies. Limitation of physical activity to prevent

tachycardia, the judicious restriction of salt intake, and the cautious use of diuretics usually relieve minor symptoms.

C. Arrhythmias

If atrioventricular nodal reentrant tachycardia occurs adenosine is the drug of choice. This drug causes no significant change in fetal heart rate because it has a half-life of only a few seconds. A bolus of 6 mg followed by 12 mg if needed is effective. Beta-adrenergic blocking agents are of proven value in the management of bothersome arrhythmias during pregnancy, mainly because other antiarrhythmic agents may pose hazards for the fetus or neonate.

D. Peripartum Cardiomyopathy

Peripartum cardiomyopathy describes heart failure that develops in women during pregnancy or the early postpartum period without a usual cause for heart failure including valvular, ischemic, congenital, or other forms of heart disease. This condition fortunately is extremely rare. These conditions are usually excluded by a clinical history and physical examination and electrocardiographic and echocardiographic findings. Echocardiography assesses depressed left ventricular function and confirms the presence or absence of valvular and congenital heart disorders. Whether peripartum cardiomyopathy is a separate entity unrelated to idiopathic dilated cardiomyopathy is controversial. In any event, improvement and full recovery is expected in approximately 50% of women within 6 months, and this type of recovery is unusual in idiopathic dilated cardiomyopathy.

Presenting symptoms of peripartum cardiomyopathy include severe shortness of breath, orthopnea, and bilateral leg edema. These symptoms occur with all forms of heart failure and are nonspecific to the diagnosis of peripartum cardiomyopathy.

BIBLIOGRAPHY

- Albert, C. M., Chae, C. U., Rexrode, K. M. et al. Phobic anxiety and risk of coronary heart disease and sudden cardiac death among women. *Circulation*, 111:480–487, 2005.
- Christou, D. D., Jones, P. P., Jordan, J. et al. Women have lower tonic autonomic support of arterial blood pressure and less effective baroreflex buffering than men. *Circulation*, 111:494–498, 2005.
- Herrington, D. M., Reboussin, D. M., Brosnihan, B. et al. Effects of estrogen replacement on the progression of coronary artery atherosclerosis. *N. Engl. J. Med.*, 343:522, 2000.

- HERS. Randomized trial of estrogen plus progestin for secondary prevention of coronary heart disease in postmenopausal women. Heart and estrogen/progestin replacement study (HERS) research group. *JAMA*, 280:650, 1998.
- Hulley, S. B., and Grady, D. Editorial: The WHI estrogen-alone trial — Do things look any better? *JAMA*, 291:1769–1771, 2004.
- Jacobs, A. K., Eckel, R. H. et al. Evaluating and managing cardiovascular disease in women: Understanding a woman's heart. *Circulation*, 111:383–384, 2005.
- Johnson, P. A., Manson, J. E. et al. How to make sure the beat goes on: Protecting a woman's heart. *Circulation*, 111:e28–e33, 2005.
- Kannel, W. B., and Abbott, R. D. Incidence and prognosis of myocardial infarction in women. The Framingham study. In *Coronary Heart Disease in Women*. E. D. Eaker, B. Packard, N. K. Wenger et al., eds. Haymarket Doyma Inc., New York, 1987, p. 208.
- Lansky, A. J., Hochman, J. S., Ward, P. A. et al. Endorsed by the American College of Cardiology Foundation: Percutaneous coronary intervention and adjunctive pharmacotherapy in women: A statement for healthcare professionals from the American Heart Association. *Circulation*, 111:940–953, 2005.
- Lerner, D. J., and Kannel, W. B. Patterns of coronary heart disease morbidity and mortality in the sexes: A 26 year follow-up of the Framingham population. *Am. Heart J.*, 111:383, 1986.
- Lipid Lowering Hormone Atherosclerosis Regression Trial Research Group. Hormone therapy and the progression of coronary artery atherosclerosis in postmenopausal women. *N. Engl. J. Med.*, 349:535–45, 2003.
- Mabie, W. C., Pernoll, M. L., and Biswas, M. K. Chronic hypertension in pregnancy. *Obstet. Gynecol.*, 67:197, 1986.
- Mieres, J. H., Shaw, L. J., Arai, A. et al. Role of noninvasive testing in the clinical evaluation of women with suspected coronary artery disease: Consensus statement from the Cardiac Imaging Committee, Council on Clinical Cardiology, and the Cardiovascular Imaging and Intervention Committee, Council on Cardiovascular Radiology and Intervention, American Heart Association. *Circulation*, 111:682–696, 2005.
- Mosca, L., Manson, J. E., Sutherland, S. E. et al. Cardiovascular disease in women: A statement for healthcare professionals from the American Heart Association. *Circulation*, 96:2468, 1997.
- Mosca, L., Merz, N. B., Blumenthal, R. S. et al. Opportunity for intervention to achieve American Heart Association guidelines for optimal lipid levels in high-risk women in a managed care setting. *Circulation*, 111:488–493, 2005. doi:10.1161/01.CIR.0000153859.66086.85.
- Sharkey, S. W., Lesser, J. R., Zenovich, A. G. et al. Acute and reversible cardiomyopathy provoked by stress in women from the United States. *Circulation*, 111:472–479, 2005.
- Sibai, B. M., Mabie, W. C., Shamsa, F., et al. A comparison of no medication versus methyldopa or labetalol in chronic hypertension during pregnancy. *Am. J. Obstet. Gynecol.*, 162:960, 1990.
- van der Schouw, Y. T., Kreijkamp-Kaspers, S., Peeters, P. H. M. et al. Prospective study on usual dietary phytoestrogen intake and cardiovascular disease risk in western women. *Circulation*, 111:465–471, 2005. doi:10.1161/01.CIR.0000153814.87631.
- WHI: Estrogen plus progestin in the risk of coronary heart disease. *N. Engl. J. Med.*, 49: 523–34, 2003.
- Wilansky, S., and Willerson, J. T. *Heart Disease in Women*. Churchill Livingstone, New York, 2002.
- Women's Health Initiative WHI; Investigators. Effects of estrogen plus progestin on health-related quality-of-life. *N. Engl. J. Med.*, 348:1839–54, 2003.
- Women's Health Initiative (WHI) Steering Committee: Effects of conjugated equine estrogen in postmenopausal women with hysterectomy. *JAMA*, 291:1701–1712, 2004.
- Writing Group For the PEPI trial. Effects of estrogen or estrogen/progestin regimens on heart disease risk factors in postmenopausal women. The postmenopausal estrogen progestin interventions (PEPI) trial. *JAMA*, 273:199, 1995.

APPENDIX A

Generic	Pharmaceutical Trade Name	Generic	Pharmaceutical Trade Name
BLOOD PRESSURE PILLS			
Beta-Blockers			
Acebutolol	Monitan, Sectral	Cilazapril	Inhibace
Atenolol	Tenormin	Enalapril	Vasotec
Carvedilol	Coreg, Eucardic	Fosinopril	Monopril
Bisoprolol	Zebeta, Monacor, Emcor	Lisinopril	Prinivil, Zestril
Labetalol	Normodyne, Trandate	Perindopril	Coversyl
Metoprolol	Betaloc, Lopressor, Toprol XL	Quinapril	Accupril
Nadolol	Corgard	Ramipril	Altace
Pindolol	Visken	Spirapril	Renpress, Sandopril,
Propranolol	Inderal, Inderal LA	Trandolapril	Mavik, Gopten
Timolol	Blocadren, Betim	Zofenopril	—
Sotalol	Sotacor		
Diuretics			
Thiazides			
Chlorothiazide	Diuril, Saluric	Angiotensin II Receptor Blocker (ARBs)	
Hydrochlorothiazide	HydroDiuril, Esidrix, Oretic, Direma	Candesartan	Atacand, Amias
Bendrofluazide	Aprinox, Berkozide, Centyl, Neo-Naclex	Eprosartan	Teveten
Metolazone	Zaroxolyn, Metenix	Irbesartan	Avapro, Aprovel
Strong Diuretics			
Furosemide, frusemide	Lasix, Dryptal	Telmisartan	Micardis
Bumetanide	Burinex, Bumex	Valsartan	Diovan
Ethacrynic acid	Edecrin	Losartan	Cozaar
Torsemide	Demadex	Losartan plus hydrochlorothiazide	Hyzzar
Diuretics that Retain Potassium			
Amiloride	Midamor	Calcium Antagonists	
Eplerenone	Inspira	Amlodipine	Norvasc
Spironolactone	Aldactone	Nifedipine	Adalat XL, Procardia XL
Triamterene	Dyrenium, Dytac	Nimodipine	Nimotop
Thiazide Combined with Potassium-Retaining Diuretic			
Nongeneric names	Aldactazide	Diltiazem	Cardizem CD
	Dyazide	Felodipine	Plendil, Renedil
	Moduretic, Moduret	Verapamil	Isoptin
Vasodilators (Dilate Arteries)			
ACE Inhibitors			
Benazepril	Lotensin	Other Antihypertensives	
Captopril	Capoten	Clonidine	Catapres
		Guanabenz	Wytensin
		Methyldopa	Aldomet, Dopamet
		Reserpine	Abicol, Decaserpyl, Raudixin, Serpasil
DRUGS USED FOR ANGINA			
Nitrates			
		Nitroglycerin (sublingual)	Nitrostat, Nitro-Bid, Nitrolingual Spray
		Isosorbide dinitrate	Coronex, Isordil, Sorbitrate, others
		Isosorbide mononitrate	Imdur
			Ismo

Generic	Pharmaceutical Trade Name	Generic	Pharmaceutical Trade Name
Beta-Blockers. See above.		DRUGS THAT AFFECT BLOOD CLOTTING	
Calcium Antagonists		Blood Thinners: Anticoagulants	
Diltiazem	Anginyl, Cardizem, Cardizem CD	Warfarin	Coumadin, Warfilone, Marevan, others
Nifedipine	Adalat XL, Procardia XL	Drugs that Reduce Stickiness of Blood Platelets	
Verapamil	Calan, Cordilox, Isoptin, Isoptin SR, Isoptino	(Not Blood Thinners)	
DRUGS FOR HEART FAILURE		Acetylsalicylic acid	Aspirin, enteric coated aspirin: Entrophen, Novasen
Digoxin	Lanoxin, others	Clopidogrel	Plavix
Furosemide and other diuretics. See above		Dipyridamole	Persantin, Persantine
ACE Inhibitors such as captopril and enalapril. See above		Potassium supplements	
ARBs if ACE inhibitors cause adverse effects		DRUGS THAT REDUCE CHOLESTEROL	
DRUGS FOR ABNORMAL HEART RHYTHMS		Fibrates	
(ARRHYTHMIAS)		Bezafibrate	Bezalip, Bezalip-Mono
Amiodarone	Cordarone, Cordarone X	Gemfibrozil	Lopid
Beta-Blockers. See above.		Fenofibrate	Lipidil, Lipidil-Micro
Digoxin	Lanoxin	Resins	
Disopyramide	Norpace, Rythmodan	Cholestyramine	Questran
Mexiletine	Mexitil	Colestipol	Colestid
Procainamide	Pronestyl	Statins	
Quinidine	Cardioquin, Quinidex	Atorvastatin	Lipitor
	Quinate, Biquin, Durules	Fluvastatin	Lescol
Sotalol	Sotacor	Lovastatin	Mevacor
		Pravastatin	Pravachol
		Rosuvastatin	Crestor
		Simvastatin	Zocor
		Cholesterol Absorption Inhibitors	
		Ezetimibe	Zetia, Ezetrol

APPENDIX B

Normal Values or Normal Range of Some Blood Constituents

mg/dL = milligram per 100 mL of blood
mEq/L = milliequivalent per liter of blood
mmol/L = millimole per liter of blood

	United States		Canada, U.K. (S.I.)
Cholesterol	150 to 200 mg/dL	÷ 38.5 =	3.9 to 5.19 mmol/L
HDL cholesterol	40 to 80 mg/dL	÷ 38.5 =	1.03 to 2.07 mmol/L
LDL cholesterol	60 to 160 mg/dL	÷ 38.5 =	1.55 to 4.15 mmol/L
LDL cholesterol (optimal)	less than 130 mg/dL	÷ 38.5 =	less than 3.37 mmol/L
LDL cholesterol (if heart trouble)	less than 100 mg/dL	÷ 38.5 =	less than 2.59 mmol/L
LDL cholesterol (serious heart attack)	less than 80 mg/dL	÷ 38.5 =	less than 2.07 mmol/L
Potassium	4 to 5 mEq/L		4 to 5 mmol/L
Triglycerides	50 to 300 mg/dL	÷ 100 =	0.5 to 3 mmol/L

GLOSSARY

A

- ACE** angiotensin-converting enzyme.
- action potential** voltage changes generated across the membrane of a nerve or muscle cells when the cell is activated through a variety of stimuli (electrical, chemical, or mechanical).
- acute coronary syndrome** this syndrome defines patients with acute chest pain caused by myocardial infarction or unstable angina.
- adventitia** the outer most lining of the vessel wall.
- afterload** arterial impedance, restriction to blood flow delivered from the left ventricle; force against which the myocardium contracts in systole; a major determinant of wall stress.
- aggregation** platelet clumping.
- aldosterone** a hormone produced by the adrenal glands.
- allograft** a graft between animals of the same species, but of different genotype.
- aneurysm** a ballooning of the wall of an artery or the heart caused by severe weakening of the walls of the artery or the heart muscle.
- angina** chest pain caused by temporary lack of blood to an area of heart muscle cells, usually caused by severe obstruction of the artery supplying blood to the segment of cells.
- angina pectoris** short duration, recurrent chest pain or pressure often accompanied by feelings of suffocation and impending doom; most frequently associated with lack of blood and oxygen to the heart muscle.
- angiogenesis** functional new blood vessel growth.
- anomaly** marked deviation from normal, especially as a result of congenital or hereditary defects.
- antiarrhythmic agents** cardioactive drugs used to prevent and treat arrhythmias.
- anticoagulants** blood thinners.
- anticoagulation** to decrease the tendency of the blood to form a clot, thrombosis.
- AOO** a pacemaker that stimulates the atrium as a fixed rate, independent of atrial activity.
- aorta** main artery arising from the heart; the branches of the aorta take blood to all parts of the body.
- apnea** cessation of airflow for at least 10 seconds.
- arcomere** the contractile unit of a myofibril; sarcomeres are repeating units, delimited by the Z bands, along the length of the myofibril that make up the myocardium of the heart.
- arrhythmia** general term for an irregularity or rapidity of the heartbeat, an abnormal heart rhythm.
- arterial dilatation** enlargement or increase in the luminal diameter of the artery.
- arterioles** small branches of arteries.
- arteriosclerosis** loss of elasticity and hardening of the artery due to several causes, particularly age change and deposits of calcium; an artery with pipe-like rigidity.
- artery** blood vessels that carry blood away from the heart to organs, tissues, and cells throughout the body, as opposed to veins, which carry blood from the tissues back to the heart.
- atrium** one of the two upper chambers of the heart.
- ascites** accumulation of serous fluid in the abdominal cavity.
- atheroma** same as atherosclerosis, raised plaques filled with cholesterol, calcium, and other substances on the inner wall of arteries that obstruct the lumen and the flow of blood; the plaque of atheroma hardens the artery, hence the term atherosclerosis (sclerosis = hardening).
- atheromatous** same as atherosclerotic, a plaque that juts into the lumen and obstructs the flow of blood in arteries.
- atherosclerosis** same as atheroma, raised plaques filled with cholesterol, calcium, and other substances on the inner wall of arteries that obstruct the lumen and the flow of blood; the plaque of atheroma hardens the artery, hence the term atherosclerosis (sclerosis = hardening).
- atherothrombosis** when a plaque of atheroma is fissured or ruptures, the contents of the plaque are highly thrombogenic and a clot (thrombus) forms rapidly causing complete occlusion of arteries leading to myocardial infarction, stroke, or other cardiovascular events (atheroma plus thrombosis = atherothrombosis).
- atrial fibrillation** the most common, persistent arrhythmia that is seen in medical practice; it may precipitate thromboembolic stroke.
- atrial septal defect** a hole in the wall of the heart (septum) that divides the left and right atrium.

autograft a tissue graft transferred from one part of the patient's body to another part.

automaticity the ability to generate a spontaneous action potential.

B

blastula usually spherical body produced by cleavage of a fertilized ovum, consisting of a single layer of cells (blastoderm) surrounding a fluid-filled cavity (blastocoel).

brachial artery the artery of the arm and forearms that supplies blood to the upper limb including the hands.

bradycardia heart rate less than 60 beats a minute.

Brugada P. Brugada described the syndrome and its electrocardiographic changes.

C

calorie a unit of energy; one calorie represents the amount of heat required to raise the temperature of one kilogram of water by one degree.

capillaries fine, thin-walled blood vessels that branch from arterioles and feed the tissues and cells with blood and fluids.

capillaries minute, thin-walled blood vessels which connect the arterioles and the venules, forming a network in nearly all organs and tissues of the body.

cardiac arrest cessation of the heartbeat.

cardiac catheterization a cardiac catheter is inserted through a vein or artery and pushed and propelled to reach inside the heart. The progress of the catheter is watched on a fluoroscope.

cardiac dysfunction the normal function of the heart is reduced; abnormal heart function.

cardiac output the volume of blood pumped by the ventricle per unit time expressed in liters per minute; it is a function of the stroke volume multiplied by the heart rate.

cardiac tamponade compression of the heart by fluid in the pericardial sac causing hemodynamic compromise that leads to cardiogenic shock and death if not immediately corrected.

cardiogenic shock extremely low blood pressures in the arteries caused by failure of the heart to eject blood; systolic blood pressure is usually less than 90 mmHg.

cardiomyopathy heart muscle disease.

cardioprotection protection of the heart from serious events that include coronary artery disease and its complications, angina, myocardial infarction, and heart failure.

catheter a flexible tube that can be inserted into body organs to achieve drainage, treatment, or diagnosis.

caudal pertaining to toward the tail or distal end of the body.

cephalic pertaining to the head or to the head end of the body.

cholesterol a lipid, or fat-like substance, made by animal cells.

commissures a site of union of corresponding parts especially the sites of junction between the adjacent cusps of the heart valves.

concentric hypertrophy diffuse generalized thickening of the myocardium with little or no change in dimensions of the left ventricular cavity as seen in pressure overload of the left ventricle.

converting enzyme the same as kinase II.

coronary arteries the arteries that supply the heart muscle and other parts of the heart with blood.

coronary heart disease obstruction of the coronary arteries with symptoms such as chest pain, angina, or heart attacks.

coronary thrombosis a blood clot in a coronary artery, blocking blood flow to a part of the heart muscle. Also called a heart attack or myocardial infarction.

creatinine breakdown of proteins excreted into the urine by the kidneys so that the composition in the bloodstream remains relatively constant.

cryptogenic of obscure or doubtful origin.

cyanosis purplish-blue discoloration of the lips, tongue, mucous membranes, ear lobes, extremities, fingers, and toes.

D

demand or inhibited pacemaker any pacemaker that inhibits its output upon sensing a natural or paced event and fires at the preset rate when the sinus rate falls below the pacemaker's programmed escape rate.

diapedese the passage of blood cells through intact vessel walls.

distal further away from the heart and near to the feet or fingers.

dyslipidemia the same as hyperlipidemia, elevated blood cholesterol, LDL cholesterol, triglycerides, or low HDL cholesterol.

dyspnea shortness of breath, usually on exertion.

E

eccentric hypertrophy hypertrophy with concomitant enlargement or dilatation of the ventricular cavity, as seen in volume overload of the left ventricle.

edema accumulation of fluid.

effusions accumulation of fluid.

ejection fraction the fraction of blood ejected from the heart into the arteries, normally this ranges from 60 to 75%; a low ejection fraction is less than 40%; often used as a marker of left ventricular contractility.

electrocardiogram test used to diagnose myocardial infarction; EKG or ECG.

embolism, embolus sudden blocking of an artery by a clot or foreign material which has been brought to its site of lodgement by the circulating blood. Pulmonary embolism is often caused by a clot (thrombus) that dislodges from a vein in the thigh or pelvis and shoots into a pulmonary artery.

embolization encrusted material, particularly small clots or bacterial vegetation on the heart valves, heart chambers, or veins which may dislodge and fly off into the circulation; they are swiftly carried to other organs, for example, pulmonary embolism.

embryo developing human from conception until the end of the 8th week by which time all organ systems have been formed.

endocarditis infection on deformed or damaged valves in the heart, or at the site of a hole in the heart (ventricular septal defect).

endocardium internal lining of the heart.

endothelial pertaining to the innermost part of the intima that comes in contact with circulating blood.

endothelial dysfunction endothelium (lining of the arteries) is influenced by many substances some of which derange the function of the endothelial cells.

endothelium the innermost part of the intima that comes in contact with circulating blood, a silky smooth layer of epithelial cells.

epistaxis hemorrhage from the nose.

F

fibrin an insoluble protein that is essential to clotting of blood, formed from fibrinogen by action of thrombin.

fitness ability to undertake physical exercise without undue fatigue; the several types of fitness include aerobic, strength, coordination, and flexibility.

Flavonoid any of a large group of crystalline compounds found in plants.

free radical an atom or group of atoms that is highly chemically reactive, because it has at least one unpaired electron; free radicals can attack cells.

free radical scavenger a substance that removes or destroys free radicals.

G

gynecomastia enlargement of the breast, usually seen in men.

H

HDL cholesterol high density lipid; the good cholesterol.

heart the size of a closed fist, it lies within the chest cavity, directly under the breastbone (sternum); the shape of the heart is conical with the apex pointing downward to the left edge of the diaphragm.

heart failure failure of the heart to pump sufficient blood from the chambers into the aorta; inadequate supply of blood reaches organs and tissues.

hemodynamics the study of the movement of blood and the forces involved in the circulation of the blood.

hemoglobin heme – “iron,” globin – “protein;” an iron-protein substance present in red blood cells that carries oxygen to the cells of the body.

heterograft a graft of tissue taken from a donor of one species and grafted into a recipient of another species, also called a xenograft.

Holter monitor a machine, the size of a handbook, that is capable of recording 24–48 hr of continuous electrocardiographic monitoring; the tracing is used to assess abnormal heart rhythms, particularly serious arrhythmias.

homograft a graft of tissue taken from a donor of the same species as the recipient.

hydrodynamics a branch of the science of mechanics which treats of liquids.

hypercholesterolemia high levels of cholesterol in the blood.

hypercoagulability increased clotting of blood.

hyperglycemia high blood glucose levels.

hyperkalemia high levels of serum potassium.

hyperplasia abnormal increase in the number of normal cells in normal arrangement in an organ or tissue which increases its volume.

hypertension high blood pressure.

hypertriglyceridemia elevated triglyceride level.

hypertrophy increase in thickness of muscle.

hypocapnia deficiency of carbon dioxide in the blood.

hypoglycemia low blood glucose.

hypokinesia decreased myocardial contraction usually caused by damage and weakness of the heart muscle due to coronary artery disease and cardiomyopathies.

hypopnea abnormal decrease in depth and rate of respiration.

hypotension marked decrease in blood pressure, usually less than 95 mmHg

hypoxemia severe lack of oxygen in the blood.

hypoxia low levels of oxygen in the blood (hypoxemia).

hypoxia, hypoxemia severe lack of oxygen in the blood.

I

infarct an area of cardiac necrosis caused by a disruption of blood supply due to blockage of the supply artery.

infarction death of cells (necrosis) caused by a marked deficit in blood supply to the area of cells.

infective endocarditis infection of the endocardial lining of heart valves with microorganisms.

inotropic an effect that affects the force of muscular contractions; negative inotropic refers to decreased myocardial contractility that may lead to poor pumping of blood, reduced ejection fraction, and heart failure.

intima the innermost lining of the vessel wall that is in contact with flowing blood.

ischemia temporary lack of blood and oxygen to an area of cells, for example, the heart muscle, usually due to severe obstruction of the artery supplying blood to this area of cells.

ischemic heart disease atherosclerosis (atheromatous plaques) causes obstruction to coronary arteries depriving the myocardium of blood containing oxygen and necessary nutrients.

K

karyotype chromosomal characteristics of an individual or cell line.

L

left ventricular assist device a device that can replace a left ventricle that is no longer able to pump blood into the aorta.

left ventricular dysfunction poor contractility of the left ventricle, this leads to heart failure.

leukocytes white blood cells, with monocytes that are scavenger white blood cells.

Lupus short for systemic lupus erythematosus (SLE).

M

macrovascular damage damage to arteries, arterioles (small arteries), and small vessels.

macula densa specialized cells in the kidney that control sodium balance.

malignant tumor the tumor that spreads to other organs.

maximal oxygen consumption the most oxygen that the body can use in aerobic exercise; synonymous with maximal aerobic fitness.

media the middle wall of the arteries.

metastases distant spread of cancer to various organs.

microvascular damage damage to capillaries.

mitochondria small spherical cytoplasmic organelles; mitochondria are the principal sites of ATP synthesis and contain enzymes of the citric acid cycle for fatty acid oxidation, oxidative phosphorylation, and other biochemical pathways. They contain their own DNA and ribosomes, replicate independently, and synthesize some of their own proteins.

mitral regurgitation the mitral valve remains open when it should be completely shut; blood rushes backwards from the left ventricle into the left atrium.

monocytes white blood cells.

murmur a blowing sound heard with a stethoscope usually caused by obstruction of heart valves or leaking valves.

mutations a permanent transmissible change in the genetic material.

myocardial infarction death of an area of heart muscle due to blockage of a coronary artery by blood clot and atheroma; medical term for a heart attack or coronary thrombosis.

myocarditis damage to the heart muscle caused by microorganisms or autoimmune and other undefined processes.

myocardium the heart muscle.

myocytes single muscle cells.

myopathy disease of muscle.

myopericarditis specific or nonspecific infection of both the pericardium and the myocardium.

N

necrosis cell death.

necrotic dead.

nephropathy kidney disease.

neutrophils white blood cells.

New York Heart Association class IV heart failure the worst stage, end-stage, severely symptomatic at rest.

nosocomial pertaining to or originating in a hospital.

notropic an effect that affects the force of muscular contractions; negative inotropic refers to decreased myocardial contractility that may lead to poor pumping of blood, reduced ejection fraction, and heart failure.

O

oligohydramnios Deficiency in the amount of amniotic fluid.

outflow tract gradient marked thickness of the left ventricular septum obstructs the blood flow from the left ventricle that is to be delivered into the aorta.

P

palpitations rapid heart rate; the patient feels the heartbeat.

paroxysmal nocturnal dyspnea patient awakens at night from sleep with severe shortness of breath and must dangle the legs or walk to an open window; relief occurs only after several minutes.

pathogenesis the development of morbid conditions or of disease, particularly the cellular events and reactions and other pathologic mechanisms occurring in the development of disease.

PCI percutaneous coronary intervention; percutaneous transluminal coronary angioplasty (PTCA), often involving the use of intracoronary stents.

pericardial effusion excess fluid within the pericardial sac.

pericarditis inflammation of the pericardium or sac surrounding the heart; this is not a heart attack.

pericardium the thin, tough membrane or sac that surrounds the heart.

phlebitis inflammation of the wall of a vein.

plaque of atheroma same as atherosclerotic, a plaque that juts into the lumen and obstructs the flow of blood in arteries.

platelet aggregation clumping together of small particles in the blood; platelets increase clot formation.

platelets very small disk-like particles that circulate in the blood alongside red and white blood cells initiating the formation of blood clots; platelets clump and form little plugs called platelet aggregation, thus causing minor bleeding to stop.

preload the degree of ventricular muscle stretch present at the onset of myocardial contraction; often expressed as end diastolic volume or pressure.

prophylaxis prevention of disease; preventive treatment.

proteinuria a leak of protein from the kidney tubules into the urine.

proximal near to a center point of the body such as the heart.

pulmonary edema fluid in the air sacs and alveoli; the lungs become congested and severe shortness of breath occurs.

Purkinje fibers the terminal branches of the cardiac conducting system that run along the subendocardium.

R

renoprotection protection of the nephrons of the kidney from damage, destruction, and amelioration of albuminuria.

retinopathy noninflammatory disease of the retina, particularly caused by diabetes or hypertension.

revascularization procedures that include coronary artery bypass surgery to bypass obstructive atheromatous plaques or percutaneous coronary intervention (PCI) using balloon angioplasty with or without stents.

rhabdomyolysis disintegration of striated muscle fibers with excretion of myoglobin in the urine.

S

S1 the first heart sound caused by closure of the mitral and tricuspid valves.

S2 the second heart sound caused by closure of the aortic and pulmonary valves.

sarcomere the contractile unit of a myofibril; sarcomeres are repeating units, delimited by the Z bands, along the length of the myofibril that make up the myocardium of the heart.

smooth muscle cells cells that are predominant in the middle wall of arteries, the media; these cells migrate into the intima to strengthen the wall that is injured during the development of atheroma or following trauma from balloon angioplasty or intracoronary stenting. The strong smooth muscle cells are nature's effective band-aid that help to fortify the damaged wall of arteries.

sodium cardiac channels cardiac cells possess channels through which sodium and potassium flow inward and outward; the exchange of positive and negative charge produces a small current.

stroke damage of part of the brain due to blockage or rupture of an artery in the brain, which leads to weakness or paralysis of limbs with or without disturbances of speech or consciousness. A stroke or cerebrovascular accident is not a form of heart attack.

sudden cardiac death death from cardiac causes that occurs instantaneously or within the hour

supraventricular tachycardia tachycardia arising in the atrium, that is above the ventricle.

sympathomimetic impulses from the sympathetic nervous system, adrenergic.

syncope temporary loss of consciousness caused by lack of blood supply to the brain; fainting describes a simple syncopal attack.

systole period of contraction of the heart muscle especially of the ventricles; blood is ejected from the ventricles.

T

tachycardia increase in heart rate exceeding 100 beats per minute.

tachypnea increased respiratory rate.

thrombi blood clots.

thrombocythemia increased levels of circulating blood platelets.

thrombocytopenia a mild decrease in platelet counts.

thromboembolic clots or thrombi that break off from the interior lining of the heart; they are propelled by the blood and become lodged in an artery supplying blood to an organ or to the extremities.

thromboembolism formation of a blood clot and a subsequent dislodgment; the thrombus is carried in the circulating blood and obstructs an artery.

thrombogenic causes clotting of the blood.

thrombus (thrombi) blood clot(s).

TIA transient ischemic attack; transient lack of blood supply (ischemia) to the brain causing symptoms of mild stroke that recover within 24 h.

tissues an aggregation of specialized cells which together perform certain special functions.

torsades de pointes a very serious, life-threatening ventricular arrhythmia.

transvenous anything that passes through a vein (catheter or pacemaker lead)

tricuspid regurgitation tricuspid valve leaks and blood is propelled backwards from the right ventricle into the right atrium and into the neck veins.

U

unstable angina severe angina usually occurring at rest.

V

valvular pertaining to the heart valves.

valvular disorders disease of heart valves, particularly mitral stenosis, mitral regurgitation, aortic stenosis, and aortic regurgitation.

valvular heart disease pertaining to diseases of the heart and the heart valves.

vasculitis inflammation of the walls of a blood vessel.

vasoconstriction narrowing, decrease in the diameter of veins or arteries.

vasodilatory dilatation of the lumen of arteries or veins; this increases blood flow.

venodilatation dilation of veins, as may occur during hot weather, hot baths, and by some drugs such as ACE inhibitors and nitroglycerin.

ventricle one of the two lower chambers of the heart.

ventricular cavity the chamber of the ventricle.

ventricular dysfunction poor contractility of the ventricle usually causing a decrease in ejection fraction.

ventricular fibrillation the heart muscle does not contract but quivers; therefore, there is no heartbeat (cardiac arrest) and no blood is pumped out of the heart; death occurs within minutes if the abnormal heart rhythm is not corrected. Note that in atrial fibrillation, the atrium fibrillates but the ventricles contract normally although faster than normal; this condition is usually not life-threatening and is easily controlled with the commonly known heart drug digoxin.

ventricular septal defect a hole in the septum, that divides the left and right ventricles.

visceral adiposity marked accumulation of fat that covers the abdominal organs, often termed abdominal obesity; the fat around the waistline also covers the internal organs within the abdomen.

W

wall tension force exerted on the vessel or chamber wall acting to pull it apart in a circumferential direction; it is a function of the radius and the pressure within the lumen or chamber.

Wolff-Parkinson-White syndrome characterized by premature excitation of the ventricles due to an anomalous conduction bypass tract between the atria and ventricles; often leads to rapid heart rates.

X

xenobiotic compound that is foreign to the body, such as a drug or an environmental pollutant.

INDEX

A

- Abciximab, as antiplatelet agent, 82
- Abdominal aortic aneurysm
- clinical studies, 30
 - from hypertension, 477
 - pathogenesis, 27–28
 - signs and symptoms, 28–29
 - treatment, 29–30
- AbioCor, 106
- ACE, *see* Angiotensin-converting enzyme
- Acebutolol
- as beta-blocker, 166
 - for hypertension, 484
- Acetazolamide, for high-altitude pulmonary edema, 10
- Acquired immunodeficiency syndrome
- and heart, 463
 - and left ventricular systolic dysfunction, 464
 - and myocarditis, 464, 541
 - pericardial effusion, 463–464
- Acromegaly, features and management, 363–364
- ACTC, *see* Alpha cardiac actin
- ACTH-dependent adenoma,
- see* Adrenocorticotrophic hormone-dependent adenoma
- Action potential, 87
- Acute atrial fibrillation, 143–145
- Acute coronary syndrome
- characteristics and treatment, 54–55
 - definition, 79, 169, 515
- Acute heart attacks, indications, 58
- Acute myocardial infarction
- ACE inhibitor indications, 63
 - beta-blocker therapy, 161
 - in coronary artery bypass surgery, 271
 - electrocardiography, 343–344, 346
 - in women, 611
- Adalat XL, *see* nifedipine
- Adenoma, ACTH-dependent,
- see* Adrenocorticotrophic hormone-dependent adenoma
- Adenovirus Gene Therapy Trial, 394
- Adrenal disorders, and heart, 364–365
- Adrenaline, *see* Epinephrine
- from stress, 569–571
- Adrenocorticotrophic hormone-dependent adenoma, 364
- Adventitia, 101
- Aerobic exercise
- caloric costs of work, 377–378
 - cardiopulmonary physiology, 376–377
 - cardiovascular training, 378–380
 - effect, 377
 - overview, 376
 - physiologic hypertrophy, 380
- Aesculus hippocastanum*, *see* Horse chestnut seed
- African-Americans
- coronary artery disease, 556
 - heart failure, 554–556
 - hypertension, 553–554
 - stroke, 556
- Afterload
- in aerobic exercise, 376
 - definition, 35, 61, 159, 229, 375, 469, 493
- AGENT, *see* Adenovirus Gene Therapy Trial
- Aggrastat, *see* Tirofiban
- Aggregation, 79
- Aging heart
- associated changes, 1–2
 - and atherosclerosis risk, 126
 - basic problem, 1
 - cardiovascular therapy, 2–3
 - research implications, 3
- AHA, *see* American Heart Association
- AIDS, *see* Acquired immunodeficiency syndrome
- Alcohol
- and abnormal heart rhythms, 7
 - and cardiomyopathy, 6–7
 - and coagulation factors, 7
 - and coronary heart disease, 5–6
 - and heart failure, 6
 - and hypertension, 6, 480
 - post-heart failure, 444–445
 - and stroke, 7
 - wine comparisons, 7–8
- Aldactone, *see* Spironolactone
- Aldosterone, 61
- Aldosterone antagonists
- as diuretics, 317–318
 - heart failure treatment, 443

- Aldosterone receptor blocking agents,
and heart hypertrophy, 498–499
- Aliskiren, for hypertension, 490
- ALLHAT, *see* Antihypertensive and Lipid-Lowering
Treatment to Prevent Heart Attack Trial
- Allograft, 277
- Alpha-blockers
and heart hypertrophy, 498
for hypertension, 489
- Alpha cardiac actin, in young athlete hypertrophic
cardiomyopathy, 133
- Alpha Tocopherol Beta-Carotene Cancer Prevention Trial, 72–73
- Altace, *see* Ramipril
- Alteplase, heart attack therapy, 416
- Alternative therapy, history and regulation, 453–454
- Ambulance transport, and heart attack, 407–409
- American Beta-Blocker Heart Attack Trial, for beta-blockers, 164
- American Heart Association
homocystinemia screening, 467
ventricular fibrillation guidelines, 216
- Amiloride, as diuretic, 317
- Amiodarone
as antiarrhythmic agent, 97–98
for cardiac arrest, 220
induced thyroid dysfunction, 598
for paroxysmal atrial fibrillation, 145–146
- Amlodipine
as angina treatment, 50–51
as calcium antagonists, 194–195
for hypertension, 488
- Amplatzer septal occluder, for atrial septal defect, 151–152
- Anabolic steroids
and athletes, 460
in athlete sudden cardiac death, 135
- Anderson-Fabry disease, 23
- Anemia
clinical studies, 25–26
and heart function, 25
severe anemia, 41
- Aneurysms
abdominal aortic aneurysm, 27–30, 477
aortic dissection, 31–32
atrial septal aneurysms, 536–537
berry aneurysm, 32
definition, 27, 175, 609
dissecting aneurysm, 162
thoracic aortic aneurysm, 30–31
- Angina, *see also* Coronary artery disease
anti-inflammatory agent treatments, 52
aspirin treatment, 51–52
atheroma, 37–38
beta-blocker therapy, 47–50, 161
CAD as cause, 35–36
calcium blocker treatments, 50–51
coronary arteriograms, 592
coronary artery bypass graft, 268
definition, 25, 79, 85, 159, 227, 233, 267, 277,
307, 363, 397, 453, 539, 569, 589, 597, 599
diagnosis, 39–40, 42
diseases causes, 40–41
and heart failure, 53
and hypertension, 53
men *vs.* women, 610–611
Nicorandil treatment, 52
nondrug treatment, 42–44
overview, 36–37
pain mechanism, 38–39
precipitation, 40
Prinzmetal's angina, 53–54
Ranolazine treatment, 52–53
and silent ischemia, 53
stable angina, 41–42, 58, 113, 268
statin treatments, 52
from stress, 569
unstable angina, 41–42, 54–55, 58, 113, 268, 277
variant angina, 40
- Anginal pain, and smoking, 337–338
- Angina pectoris
characteristics, 40
definition, 57, 193, 375, 391
- Angiogenesis
and atherosclerotic plaques, 126
definition, 117
- Angiograms
for angina, 42
for pulmonary embolism, 551
- Angiopeptin, in drug-eluting stents, 567
- Angioplasty,
see Percutaneous transluminal coronary angioplasty
for angina treatment, 55
heart attack therapy, 416–417
- Angiotensin-converting enzyme, 61
- Angiotensin-converting enzyme inhibitors
adverse effects, 65
for African-American heart failure, 555–556
and anthracycline-induced heart disease, 230
associated research, 63–65
and atrial fibrillation, 142
available blockers, 62
and heart attack, 415
for heart failure, 419, 440–441
and heart hypertrophy, 498
for hypertension, 487
hypertension treatment, 480–481
indications, 62–63
interactions, 65
mechanism of action, 61–62
- Angiotensin II, and hypertrophy, 494
- Angiotensin II receptor blockers
available blockers, 65–66
clinical trials, 66
in heart failure treatment, 440–442

- mechanism of action, 65
- Ankylosing spondylitis, 507
- Anomalous coronary arteries, as angina cause, 41
- Anomaly, 131
- Anorectic agents, and coronary artery disease, 310–311
- Anthracyclines, in heart damage, 229–231
- Antiarrhythmic agents
 - amiodarone, 97–98
 - beta-blockers, 96
 - definition, 281
 - digoxin, 96
 - disopyramide, 98
 - lidocaine, 98
 - mexiletine, 98
 - overview, 95–96
 - procainamide, 98–99
 - quinidine, 99–100
 - sotalol, 96–97
- Antibiotics, for endocarditis, 360
- Anticoagulants
 - for atrial fibrillation, 148–149
 - definition, 169
 - garlic activity, 456–457
- Anticoagulation, 77
- Antidepressant heart attack randomized trial, 291–292
- Antihistamine, 69
- Antihypertensive and Lipid-Lowering Treatment to Prevent Heart Attack Trial, 3
- Antihypertensive agents
 - examples, 483–490
 - hypertension with coexisting diseases, 482
- Anti-inflammatory agents, for angina treatment, 52
- Antioxidants, *see* specific antioxidants
 - beta-carotene, 73–74
 - dietary plant-derived flavonoids, 74
 - French red wine, 74–75
 - Mediterranean diet effects, 74
 - overview, 71
 - probucol, 75
 - statins, 71
 - vitamin C, 73
 - vitamin E, 72–73
- Antiphospholipid antibody syndrome
 - diagnosis, 77
 - management, 77
- Antiplatelet agents
 - aspirin, 80–81
 - blood clot treatment, 171–172
 - Clopidogrel, 81–82
 - garlic as, 456–457
 - indications, 80
 - mechanism of action, 79–80
- Anxiety, post-heart attack, 420–421
- AOO, 525
- Aorta
 - and atherosclerosis, 125
 - in athlete sudden cardiac death, 134
 - coarctation in CHD, 254–255
 - definition, 27
 - in heart disease, 119–120
 - and Marfan syndrome, 505
 - and secondary hypertension, 472
- Aortic dissection
 - diagnostic testing, 31–32
 - management, 32
 - signs and symptoms, 31
- Aortic regurgitation, 603–604
- Aortic semilunar valve, anatomy, 18f
- Aortic stenosis
 - as angina cause, 41
 - characteristics, 602–603
 - congenital heart disease, 254
- Aortic valve stenosis, echocardiography, 329
- APBs, *see* Atrial premature beats
- APLA, *see* Antiphospholipid antibody syndrome
- Apnea, 559
- Aprovel, *see* Irbesartan
- ARBs, *see* Angiotensin II receptor blockers
- Argatroban, blood clot treatment, 173–174
- L-Arginine
 - as angina treatment, 44
 - and cardiovascular disease, 459
 - for primary pulmonary hypertension, 547
- Arginine, clinical studies, 85
- Arm pain, as heart attack mimic, 407
- Arrhythmias
 - automatic implantable cardioverter defibrillator, 100
 - beta-blocker therapy, 162
 - in coronary artery bypass surgery, 272
 - definition, 5, 25, 35, 61, 69, 79, 131, 139, 159, 175, 189, 193, 223, 313, 335, 341, 353, 363, 375, 397, 449, 453, 463, 493, 515, 539, 559, 575, 581, 599, 609
 - electrocardiographic detection, 347, 349
 - from hypertension, 477
 - and ischemic zone, 399
 - in myocardial infarction, 418–419, 420
 - and pregnancy, 614
 - and sleep apnea, 563
- Arrhythmogenic right ventricular dysplasia
 - in athlete sudden cardiac death, 135
 - and ventricular fibrillation, 608
- Arterial blood gas analysis, for pulmonary embolism, 550
- Arterial dilatation, 453, 501
- Arteries
 - abdominal aortic aneurysm, 28
 - anomalous coronary arteries, 41
 - and atherosclerosis, 125–126
 - brachial arteries, 85
 - carotid arteries, 120–121
 - coronary, *see* Coronary arteries
 - in heart disease, 119–121
 - hypertension effects, 476–477

- Arteries [*continued*]
 internal mammary arteries, 269
 left anterior descending arteries, 267, 269, 333
 leg arteries, 121
 pulmonary arteries, 121, 125
 radial arteries, 269
 renal arteries, 121
 trauma from stress, 569
 upper limb arteries, 125
- Arterioles, 391
- Arteriosclerosis
 definition, 175
 diseases causing, 101–102
- Arteriovenous malformations, in adults, 256
- Artificial heart
 clenbuterol treatment, 109
 electric total artificial heart, 105–107
 left ventricular assist device, 107–108
 overview, 105
 post-heart failure, 444
 ventricular assist devices, 107–108
- ASA, *see* Atrial septal aneurysms
- Ascites, 543
- Asian Indians, heart disease, 556–557
- ASO, *see* Amplatzer septal occluder
- Aspirin
 as angina treatment, 51–52
 as antiplatelet agent, 80–81
 blood clot treatment, 171
 coronary artery bypass surgery, 273
 historical overview, 111–112
 indications and dose, 113–114
 for Kawasaki syndrome, 502
 mechanism of action, 112
- Atacand Amias, *see* Candesartan
- ATBC, *see* Alpha Tocopherol Beta-Carotene Cancer Prevention Trial
- Atenolol
 for angina treatment, 49–50
 as beta-blocker, 166
 for hypertension, 484–485
 post-heart attacks, 425
 pregnancy hypertension, 613
- Atheroma, *see also* Atherosclerosis
 associated arteries, 119–121
 causes, 36
 characteristics, 37–38
 definition, 27, 35, 57, 111, 117, 119, 131, 169, 233, 267, 277, 293, 375, 397, 465, 565, 575, 581, 589, 609
 exercise effects, 381–382
 history, 118
- Atheromatous, definition, 201
- Atheromatous plaques
 anti-inflammatory agent effects, 52
 and blood clots, 170
 characteristics, 37
 definition, 227
 hemorrhage, 127
 lining erosion, 127
 rupture, 127
- Atherosclerosis, *see* Atheroma
 in angina, 40
 associated arteries, 119–121, 125–126
 characteristics, 102–103
 and cigarette smoke, 337
 clinical studies, 127–128
 definition, 13, 71, 79, 105, 119, 159, 227, 335, 391, 469, 515, 519, 569
 and gene therapy, 394–395
 HDL effects, 238
 history, 118
 hydrodynamic forces, 124–125
 incidence, 117–118
 pathogenic theories, 121–124
 research studies, 118, 128–130
 risk factors, 126
- Atherosclerotic plaques, and angiogenesis, 126
- Atherothrombosis
 definition, 117, 575
 NSAID effects, 516
 in women, 611–612
- Athletes
 dietary supplements, 460
 normal heart *vs.* hypertrophic cardiomyopathy, 136
 sudden cardiac death, 132–135
- Atkins-type diet
 for heart disease, 307
 for obesity, 523–524
- Atorvastatin, for cholesterol lowering, 244
- ATP, in cardiovascular training, 379–380
- Atrial fibrillation, *see also* Ventricular fibrillation
 acute atrial fibrillation, 143–145
 anticoagulant treatments, 148–149
 causes, 141–143
 characteristics, 93
 in coronary artery bypass surgery, 272
 definition, 267
 diagnosis, 140
 in elderly, 1
 electronic pacing, 149
 epidemiology, 140
 idiopathic atrial fibrillation, 143
 overview, 139
 paroxysmal atrial fibrillation, 145–146
 pathophysiology, 143
 permanent atrial fibrillation, 148
 persistent atrial fibrillation, 147–148
 and ventricular fibrillation, 608
- Atrial myxoma, 509
- Atrial pacing
 for atrial fibrillation, 149
 and sleep apnea, 562

- Atrial premature beats, diagnosis, 89
- Atrial septal aneurysms, and patent foramen ovale, 536–537
- Atrial septal defect
- clinical study, 151–152
 - definition, 319
 - overview, 151
- Atrioventricular nodal reentrant tachycardia, 90–93
- Atrioventricular node
- for atrial fibrillation, 149
 - function, 139–140
 - second degree block, 528
 - third degree block, 527–528
- Atropine, for cardiac arrest, 221
- Autograft, 251
- Automated external defibrillator, 216
- Automatic implantable cardioverter defibrillator, 100
- Automaticity, 87
- Avapro, *see* Irbesartan
- AVMs, *see* Arteriovenous malformations
- AV node, *see* Atrioventricular node
- AVNRT, *see* Atrioventricular nodal reentrant tachycardia
- B**
- Bad cholesterol, *see* Low-density lipoproteins
- BARI, *see* Bypass Angioplasty Revascularization Investigation
- Behavior, type A, and stress, 572
- Belgian-Netherlands stent study, and stent acceptance, 565
- Belladonna, 460
- BENESTENT, *see* Belgian-Netherlands stent study
- Benzothiazepines, 195
- Beriberi heart disease, 157
- Berry aneurysm, 32
- Beta-1 receptors, 160
- Beta-2 receptors, 160
- Beta-blockers
- for acute atrial fibrillation, 143
 - adverse effects, 164
 - and African-Americans, 556
 - agent differences, 165–166
 - for angina treatment, 47–50
 - as antiarrhythmic agent, 96
 - and atrial fibrillation, 142
 - for cardiac arrest, 220–221
 - in cardiomyopathy sudden death, 208–209
 - classification, 164–165
 - clinical trials, 163–164
 - coronary artery bypass surgery, 273
 - cytochrome P-450 interactions, 285
 - examples, 166–167
 - and heart attack, 415
 - for heart attack pain, 414–415
 - for heart failure, 419, 442–443
 - and heart hypertrophy, 498
 - for hypertension, 483–486
 - hypertension treatment, 481–482
 - indications, 161–163
 - mechanism of action, 160
 - for non-ST elevation myocardial infarction, 418
 - for paroxysmal atrial fibrillation, 145–146
 - for permanent atrial fibrillation, 148
 - post-heart attacks, 424–426
 - research implications, 164
 - salutary effects, 160–161
 - therapy in elderly, 2
 - thoracic aortic aneurysm treatment, 31
- Beta-carotene, antioxidant effects, 73–74
- Betaloc, *see* Metoprolol
- Beta myosin heavy chain gene
- in hypertrophic cardiomyopathy, 204
 - in young athlete hypertrophic cardiomyopathy, 133
- Beta-receptors, 160
- Bezafibrate
- for cholesterol lowering, 245
 - for dyslipidemia, 325
- BHAT, *see* American Beta-Blocker Heart Attack Trial
- Bicuspid aortic valve, congenital heart disease, 254
- Bile acid sequestrant resin, 326
- Bioprosthetic valves, 604–606
- Bisoprolol
- for angina treatment, 50
 - as beta-blocker, 166
 - for hypertension, 485
 - post-heart attack, 425
- Bivalirudin, blood clot treatment, 173–174
- Black tea, and cardiovascular disease, 460
- Blastula, 353
- Bleeding, in coronary artery bypass surgery, 272
- Blood clots
- antiplatelet agent treatments, 171–172
 - causes, 169–170
 - in heart attack, 398
 - heparin treatment, 173–174
 - nondrug treatments, 170
 - oral anticoagulant treatments, 172–173
 - overview, 169
 - thrombolytic agent treatment, 170–171
- Blood-clotting factors, exercise effects, 382–383
- Blood flow
- caffeine effects, 190
 - exercise effects, 382–383
 - heart as pump, 21
- Blood pressure
- caffeine effects, 190
 - classification, 178
 - daytime and nighttime variability, 179
 - early measurement methods, 175–178
 - early sphygmomanometry, 175
 - exercise effects, 381–382
 - finger cuff measurement, 180
 - as heart attack warning, 404
 - high pressure effects, 180

- Blood pressure [*continued*]
 home measurements, 179–180
 level conventions, 471
 marked variability, 178–179
 measurement techniques, 180, 469–471
 pseudohypertension, 179
 systolic and diastolic, 178
 white-coat hypertension, 179
- Blood supply, and stress, 569–570
- Blood tests
 for Chagas disease, 225
 for extra heartbeats, 88
 HDLs, 241
 for heart attacks, 412–413
 for hypertension, 477–478
 LDL, 240–241
 total cholesterol, 240
- Blood vessels, caffeine effects, 190
- BNP, *see* B-type natriuretic peptide
- Body temperature, in blood clots, 169–170
- Brachial arteries, 85
- Bradyarrhythmias
 in myocardial infarction, 419
 in syncope, 583–584
- Bradychardia
 definition, 581
 in syncope, 587
- Bradycardia syndrome, 142
- Brain-acting drugs, and hypertension, 489–490
- Breathing
 CPR steps, 217
 as heart attack warning, 403–404
 shortness, *see* Shortness of breath
- Bretylum, for cardiac arrest, 221
- Bronchitis, in cor pulmonale, 506
- Brugada syndrome
 in athlete sudden cardiac death, 135
 clinical features, 183–184
 definition, 183
 overview, 183
 research perspective, 184
 in syncope, 584
 and ventricular fibrillation, 608
- B-type natriuretic peptide
 clinical studies, 153–154
 diagnostic perspective, 154–155
 in heart failure diagnosis, 438
 overview, 153
- Bundle branch block, 185–187
- Bypass Angioplasty Revascularization Investigation, 303
- Bypass surgery, for angina treatment, 55
- C**
- CABG, *see* Coronary artery bypass graft surgery
- CAD, *see* Coronary artery disease
- Caffeine
 associated biochemistry, 189
 cardiovascular effects, 190–191
 overview, 189
- Calcification
 aging heart, 2
 in arteriosclerosis, 102
- Calcium, coronary, evaluation, 593
- Calcium antagonists
 for angina treatment, 50–51
 and atrial fibrillation, 142
 benzothiazepines, 195
 coronary artery bypass surgery, 273
 dihydropyridines, 194–195
 in elderly, 2–3
 and heart hypertrophy, 498
 for hypertension, 480, 488
 mechanism of action, 193–194
 next generation agents, 196–197
 for paroxysmal atrial fibrillation, 145–146
 phenylalkylamines, 195–196
 for primary pulmonary hypertension, 546
 therapeutic benefits, 196
- Caloric costs, in aerobic exercise, 377–378
- Cambridge Heart Antioxidant Study, 72
- Canadian Cardiac Randomized Evaluation of
 Antidepressant and Psychotherapy Efficacy, 292
- Canadian Task Force, homocystinemia screening, 467
- Candesartan, heart failure treatment, 441
- Capillaries
 definition, 13, 391
 rupture, 399
- Capoten, *see* Captopril
- CAPRICORN Study
 for beta-blockers, 164
 heart failure treatment, 442
- CAPRIE study, for Clopidogrel, 81
- Captim, heart attack clinical trials, 417
- Captopril
 heart failure treatment, 441
 for hypertension, 487
- Capture, definition, 525
- Carace, *see* Lisinopril
- Carbohydrates, and obesity, 522
- Carbon monoxide
 and blood clots, 170
 in cigarette smoke, 336–337
- Carcinoid heart disease
 clinical study, 200
 diagnosis, 199
 heart damage, 199
 overview, 199
 treatment, 200
- Cardiac arrest
 and CPR, 216
 drugs for, 220–221

- in loss of consciousness, 216
- out-of-hospital outcomes, 221–222
- recognition in CPR, 217
- Cardiac catheterization
 - historical overview, 591
 - indications, 592–593
 - technique, 591–592
- Cardiac dysfunction, 25
- Cardiac enzymes, and heart attacks, 412–413
- Cardiac nuclear scans, for angina, 42
- Cardiac output
 - in aerobic exercise, 376
 - definition, 189, 215, 511
- Cardiac resynchronization therapy, 443–444
- Cardiac tamponade
 - characteristics, 540
 - definition, 215
- Cardiac troponin-T
 - in hypertrophic cardiomyopathy, 204
 - in young athlete hypertrophic cardiomyopathy, 133
- Cardiogenic shock
 - causes, 201
 - definition, 157
 - management, 202
 - pathophysiology, 201–202
 - research implications, 202
- Cardiomyopathy
 - and alcohol, 6–7
 - definition, 5, 87, 139, 223, 293, 363, 433, 449, 463, 493, 581
 - dilated cardiomyopathy, 209–211
 - as heart failure cause, 435
 - hypertrophic, *see* Hypertrophic cardiomyopathy
 - overview, 203–204
 - peripartum cardiomyopathy, 614
 - restrictive cardiomyopathy, 211
 - sudden death, 207–209
- Cardioprotection
 - definition, 5, 71, 515
 - Framingham Offspring Cohort, 6
- Cardiopulmonary resuscitation
 - cardiac arrest recognition, 217
 - cardiac arrest rhythms, 216
 - circulation, 217–219
 - defibrillation, 219–220
 - out-of-hospital outcomes, 221–222
 - overview, 216
 - research implications, 221
 - steps, 217
- Cardiotoxicity, in anthracycline-induced heart disease, 230
- Cardiovascular disease effects
 - L-arginine, 459
 - Danshen, 454
 - Ephedra sinica*, 454–455
 - erectile dysfunction, 369
 - feverfew, 457–458
 - garlic, 456–457
 - ginger, 457
 - ginkgo biloba, 455–456
 - ginseng, 457
 - gugulipid, 458
 - hawthorn, 458
 - hellebore, 459
 - historical remedies, 453
 - horse chestnut seed, 458
 - kava, 459
 - licorice, 459
 - linoleic acid, 459
 - natural product, 460
 - St. John's wort, 459
 - supplements for, 453–454
 - in syncope, 583–584
 - yohimbine, 459–460
- Cardiovascular magnetic resonance imaging, 593–594
- Cardiovascular system
 - normal sleep effects, 559
 - stress effects, 569–571
- Cardiovascular therapy, in elderly, 2–3
- Cardiovascular training, training effect, 378–380
- Cardizem, *see* Diltiazem
- CARE, *see* Cholesterol and Recurrent Events
- CARET, *see* Carotene and Retinol Efficacy Trial
- Cardizem, *see* Diltiazem
- Carotene and Retinol Efficacy Trial, 73
- Carotid arteries, in heart disease, 120–121
- Carotid endarterectomy, 577–578
- Carotid sinus, hypersensitivity in syncope, 583
- Carvedilol, for angina treatment, 50
 - as beta-blocker, 166
 - for hypertension, 485
 - post-heart attacks, 425
- Catecholamines
 - definition, 159
 - in myocardial infarction, 398–399
 - in vasovagal syncope, 582–583
- Catheterization
 - historical overview, 591
 - indications, 592–593
 - technique, 591–592
- Caudal, 353
- CCU, *see* Coronary care units
- Central retrosternal chest pain, 401
- Central sleep apnea, 560
- Cephalic, 353
- Cerebral infarction, 576
- Cerebrovascular accident, 575
- CETP, *see* Cholesteryl ester transfer protein
- Chagas disease
 - acute phase, 223–224
 - in complete heart block, 527
 - diagnosis, 225
 - latent and chronic phases, 224–225

- Chagas disease [*continued*]
 management, 225
 transmission, 223
- CHAOS, *see* Cambridge Heart Antioxidant Study
- CHARM Program, 66, 441–442
- CHD, *see* Congenital heart disease; Coronary heart disease
- Chelation, clinical study and research, 227–228
- Chemical septal ablation, in cardiomyopathy
 sudden death, 209
- Chemotherapeutic agents
 as angina cause, 41
 heart disease induction, 229
- Chemotherapy-induced heart disease
 from anthracyclines, 229–231
 chemotherapeutic agents, 229
 cyclophosphamide, 231
 5-fluorouracil, 231–232
- Chest compression, in CPR, 217–219
- Chest pain
 as heart attack mimic, 407
 men *vs.* women, 610–611
- Chest X-ray
 for Chagas disease, 225
 in heart failure diagnosis, 438
 and mitral stenosis, 601–602
 overview, 590
 primary arterial hypertension, 544
- Chlamydia pneumoniae*, in atherosclerosis, 122
- Cholesterol
 absorption inhibitors, 245
 and atheroma, 118
 bad, 237
 blood tests, 240–241
 caffeine effects, 191
 combination therapy, 245–246
 coronary artery disease risk, 241–242
 diet advice, 243–244
 drugs for lowering, 244–245
 good, 237–240
 high-density, *see* High-density lipoproteins
 historical and clinical trials, 233–235
 and linolenic acid, 242
 low-density, *see* Low-density lipoproteins
 and nuts, 243
 overview, 233
 and polyunsaturates, 242
 and saturated fats, 242
 size of problem, 233
 total, 237
 types, 236–237
 very-low-density lipoproteins, 240
- Cholesterol absorption inhibitors, for dyslipidemia, 325
- Cholesterol and Recurrent Events, 235
- Cholesteryl ester transfer protein
 and atherosclerosis, 128
 and dyslipidemia management, 302
- Cholestyramine
 for cholesterol lowering, 245
 dyslipidemia treatment, 326
- Chronic bronchitis, in cor pulmonale, 506
- Chronic coronary artery disease, in atrial fibrillation, 142
- Chronic kidney diseases, in secondary hypertension, 472
- Chronic obstructive lung disease, in cor pulmonale, 506
- CIBIS-II trial, heart failure treatment, 442–443
- Cigarette smoking, *see also* Smoking
 and atherosclerosis, 126, 337
 carbon monoxide, 336–337
 HDL level variability, 239
 nicotine, 336
 overview, 335
 tar fraction, 337
- Circulation
 and CPR, 217–219
 and heart anatomy, 16
- CKIs, *see* Cyclin-dependent kinase inhibitors
- Clenbuterol, and artificial hearts, 109
- Clonidine, for hypertension, 489
- Clopidogrel
 blood clot treatment, 172
 clinical studies, 81–82
 for non-ST elevation myocardial infarction, 418
 ticlopidine comparison, 82
- CMR, *see* Cardiovascular magnetic resonance imaging
- CMV, *see* Cytomegalovirus
- Coagulation factors
 and alcohol, 7
 in deep vein thrombosis, 288
 oral contraceptive risk, 263
- Cocaine, in athlete sudden cardiac death, 135
- Coenzyme Q10
 actions, 247
 clinical study, 247–249
 research implications, 249
- Coffee
 diabetes type 2 risk, 302–303
 and hypertension, 480
- Colesevelam, dyslipidemia treatment, 326
- Collagen, in Ehlers-Danlos syndrome, 506
- Collagen vascular disease, 527
- COMET trial, 443
- Commiphora mukul*, *see* Gugulipid
- Commissures, 251
- Commotio cordis, in athlete sudden cardiac death, 135
- Compensatory hypertrophy, 493–494
- Complete heart block, 526–528
- Computed tomography
 for aortic dissection, 32
 primary arterial hypertension, 544
- Concentric hypertrophy, 493
- Congenital cyanotic heart disease, 256–258
- Congenital heart disease
 aorta coarctation, 254–255

- aortic stenosis, 254
- bicuspid aortic valve, 254
- classification, 251
- in complete heart block, 527
- in Down syndrome, 319
- echocardiography, 330
- patent ductus arteriosus, 253–254
- and patent foramen ovale, 533
- and pregnancy, 258, 261
- in right bundle branch block, 186
- ventricular septal defects, 252–253
- Connective tissue, and heart hypertrophy, 495
- Conn's syndrome, *see* Hyperaldosteronism
- Constrictive pericarditis, characteristics and management, 540–541
- Converting enzyme, 61
- COPD, *see* Chronic obstructive lung disease
- COPERNICUS trial, heart failure treatment, 442–443
- Coreg, *see* Carvedilol
- Corgard, *see* Nadolol
- Coronary angiograms, for angina, 42
- Coronary angioplasty, heart attack therapy, 416–417
- Coronary arteries
 - adult anomalies, 255–256
 - anatomy, 18f, 19–21
 - and atherosclerosis, 125
 - in athlete sudden death, 134
 - definition, 13
 - in heart disease, 120
 - overview, 267
 - spasm in variant angina, 40
 - transthoracic visualization, 333
- Coronary arteriography
 - historical overview, 591
 - indications, 592–593
 - technique, 591–592
- Coronary artery bypass graft surgery
 - angioplasty comparison, 59
 - aspirin treatment, 113
 - complications, 271–272
 - contraindications, 273
 - in elderly, 272–273
 - first time, 267
 - indications, 268
 - life prolongation, 270–271
 - medication advice, 273–274
 - mortality and morbidity factors, 271
 - PCI comparison, 274–275
 - perioperative medications, 273
 - postoperative maintenance, 273
 - survival, 270
 - symptomatic relief, 271
 - types, 268–269
- Coronary artery disease, *see also* Angina
 - in African-Americans, 556
 - as angina cause, 35–36
 - in Asian Indians, 556–557
 - in athlete sudden death, 134
 - in atrial fibrillation, 142
 - and B-type natriuretic peptide, 154
 - cholesterol risk, 241–242
 - in complete heart block, 527
 - controversial diets, 307
 - definition, 307, 321
 - diet-drug valvulopathy, 310–311
 - echocardiography, 330
 - and fish oils, 311
 - as heart failure cause, 434–435
 - left main, bypass graft, 268
 - recommended diets, 307–308
 - in right bundle branch block, 186
 - and trans fatty acids, 308–310
 - in ventricular fibrillation, 607–608
- Coronary calcium, evaluation, 593
- Coronary care units, heart attacks, 410–411
- Coronary heart disease, *see also* Coronary artery disease
 - and alcohol, 5–6
 - and atheroma, 37–38
 - definition, 1, 233
 - and obesity, 521
- Coronary thrombosis, 1
- Cor pulmonale, diagnosis and management, 505–506
- Corticosteroids, for Kawasaki syndrome, 502
- Cough
 - as heart attack warning, 404
 - from high-altitude pulmonary edema, 9
- Coumadin, blood clot treatment, 172–173
- COX, *see* Cyclooxygenase
- CPR, *see* Cardiopulmonary resuscitation
- Crataegus species, *see* Hawthorn
- C-reactive protein
 - clinical studies, 278–279
 - research implications, 279–280
 - as risk marker, 277–278
- CREATE, *see* Canadian Cardiac Randomized Evaluation of Antidepressant and Psychotherapy Efficacy
- Creatine
 - and athletes, 460
 - definition, 25
- CREDO Trial, for Clopidogrel, 81–82
- CRP, *see* C-reactive protein
- Cryptogenic, 533
- CSA, *see* Central sleep apnea
- CT, *see* Computed tomography
- CURE Trial, for Clopidogrel, 81
- Cushing's syndrome
 - and heart, 364
 - and secondary hypertension, 473
- Cyanosis, 251
- Cyclin-dependent kinase inhibitors, and gene therapy, 395

- Cyclooxygenase
 and aspirin mechanism, 112
 NSAID effects, 80
- Cyclooxygenase inhibitors, 515
- Cyclophosphamide, heart disease induction, 231
- Cyclosporine, type 1 diabetes studies, 305
- Cytochrome P-450
 beta-adrenergic blocking agent interactions, 285
 definition, 281
 functions, 281–283
 regulation, 283
 statin interactions, 283, 285
- Cytomegalovirus
 in atherosclerosis, 122
 and NSAIDs, 516–517
- ## D
- Dacron, abdominal aortic aneurysm treatment, 29
- Danshen, and cardiovascular disease, 454
- DCM, *see* Dilated cardiomyopathy
- Dean Ornish program, for heart disease, 307
- Death
 from high-altitude pulmonary edema, 9
 sudden cardiac death, *see* Sudden cardiac death
- Deep vein thrombosis
 diagnosis, 288–289
 incidence and location, 287
 management, 289–290
 and oral contraceptives, 264
 and patent foramen ovale, 536
 pathogenesis, 287–288
- Defibrillation
 in CPR, 219–220
 errors, 220
- Definitive medical management, aortic dissection, 32
- Demand pacemaker, 525
- Depression
 drug management, 291–292
 overview, 291
 pathophysiologic mechanisms, 291
 post-heart attack, 420–421
- Dextrocardia, in adults, 256
- Diabetes mellitus
 and atherosclerosis risk, 126
 beta-blocker therapy, 163
 caffeine effects, 191
 coronary artery bypass graft, 268
 in erectile dysfunction, 369
 HDL level variability, 239
 incidence, 293–294
 vascular abnormalities, 298
- Diabetes Prevention Trial-Type I, 305
- Diabetes type 1
 management, 305
 pathogenesis, 303–304
 pathologic features, 304–305
 research studies, 305–306
 symptoms and complications, 305
- Diabetes type 2
 clinical studies, 302
 coffee consumption risk, 302–303
 diagnosis, 294–295
 dyslipidemia, 298–299, 301–302
 features, 295
 fibrinolysis defect, 299
 genetic abnormalities, 299
 hyperglycemic hyperosmolar coma, 301
 insulin effects, 298
 insulin resistance, 303
 insulin secretion, 295–297
 management, 299–301
 mechanisms, 297–298
 nephropathy, irbesartan effects, 66
 symptoms, 294
 thrombosis defect, 299
- Diabetic distress, and cardiovascular disease, 294
- Diapedese, 117
- Diastolic blood pressure, 178
- Diastolic heart murmurs, 514
- Diet
 antioxidant effects, 74
 cholesterol advice, 243–244
 controversial diets, 307
 for heart attack prevention, 428–429
 and obesity, 521–523, 523–524
 post-heart attack, 421
 post-heart failure, 444–445
 recommended diets, 307–308
- Dietary supplements
 athletes, 460
 and cardiovascular disease, 454–460
 regulation, 453–454
- Diet-drug valvulopathy, 310–311
- Digitalis
 for African-American heart failure, 556
 as antiarrhythmic agent, 96
 heart failure treatment, 438–439
 for paroxysmal atrial fibrillation, 145–146
- Digitoxin, heart failure treatment, 439–440
- Digoxin, *see* Digitalis
- Dihydropyridines, as calcium antagonists, 194–195
- Dilated cardiomyopathy, 209–211
- Diltiazem
 as angina treatment, 51
 as calcium antagonist, 195
 for hypertension, 488
- D-Dimer, in deep vein thrombosis diagnosis, 288–289
- Dipyridamole, blood clot treatment, 171–172
- Disopyramide, as antiarrhythmic agent, 98

- Dissecting aneurysm, beta-blocker therapy, 162
- Distal, definition, 287
- Diuretics
 for African-American heart failure, 555
 aldosterone antagonists, 317–318
 and atrial fibrillation, 142
 for heart failure, 419, 442
 and heart hypertrophy, 498
 for hypertension, 486–487
 indications, 313
 loop diuretics, 316–317
 potassium-sparing diuretics, 317–318
 pregnancy hypertension, 613–614
 thiazides, 315–316
- Dizziness, as heart attack warning, 404
- DNA, gene therapy strategies, 391–392
- Door-to-needle time, for heart attacks, 400
- Doppler echocardiography, 603
- Down syndrome
 congenital heart malformations, 319
 genetics, 319
- Drug-eluting stents
 coronary bypass surgery, 274
 types, 566–567
- Drug interactions
 Danshen, 454
Ephedra sinica, 454–455
- Drug therapy
 for cardiac arrest, 220–221
 for cholesterol lowering, 244–246
 in complete heart block, 527
 cytochrome P-450 interactions, 283, 285
 for depression management, 291–292
 for dyslipidemia, 324–326
 HDL level variability, 239
 for heart failure, 438–443
 for hypertension, 480–482
 nitrate treatment, 45–47
 in pericarditis, 539
 post-heart failure, 444–445
 pregnancy hypertension, 613–614
 for type 2 diabetes, 299–300
 for unstable angina treatment, 55
- Dual-chamber pacemaker, in cardiomyopathy
 sudden death, 209
- DVT, *see* Deep vein thrombosis
- Dyazide, for hypertension, 486
- Dyslipidemia
 abnormalities, 323–324
 bile acid sequestrant resin treatment, 326
 cholesterol absorption inhibitor treatment, 325
 definition, 159, 233, 277, 321, 367, 453, 519
 diabetes type 2, 301–302
 fibrate treatment, 325
 statin treatment, 324–325
 torcetrapib treatment, 326
 and type 2 diabetes, 298–299
 in women, 611
- Dyspnea, 153, 543
- ## E
- Ebstein's anomaly, 507
- EBT, *see* Electron beam tomography
- Eccentric hypertrophy, 493
- ECG, *see* Electrocardiography
- Echocardiography
 for Chagas disease, 225
 clinical indications, 332
 congenital heart disease, 330
 coronary artery disease, 330
 Doppler echocardiography, 603
 examination technique, 328–329
 handheld instruments, 333
 heart attacks, 413
 heart failure, 330, 438
 historical background, 327–328
 instrumentation, 328
 overview, 590
 primary arterial hypertension, 544
 research studies, 332
 in syncope diagnosis, 585
 thrombus, 329
 transthoracic visualizations, 333
 valvular heart disease, 329
- ED, *see* Erectile dysfunction
- Edema
 definition, 153, 287, 293
 and diuretics, 313
 high-altitude, *see* High-altitude pulmonary edema
 pulmonary edema, 9, 157, 159, 193, 247
- EF, *see* Ejection fraction
- Effusions, 157
- Ehlers-Danlos syndrome, 30, 506
- Ejection fraction
 definition, 25, 35, 57, 193, 223, 267, 397, 433, 449, 463, 553, 559, 607
 in heart disease test, 591
- Elderly
 aortic dissection, 31
 atrial fibrillation, 1
 cardiovascular therapy, 2–3
 coronary artery bypass surgery, 272–273
 type 2 diabetes complications, 301
- Electrical conduction system
 in aging heart, 2
 in athlete sudden cardiac death, 135
 defects, 346
- Electric total artificial heart
 AbioCor, 106
 Lionheart, 106–107
 overview, 105–106

- Electrocardiography
acute myocardial infarction, 343–344, 346
and alcohol, 7
for angina, 42
arrhythmia, 347, 349
and atrial fibrillation, 139–141
Brugada syndrome, 183
characteristics, 589
in coronary care unit, 410
definition, 35
electrical conduction defects, 346
during exercise, 387
general applications, 342–343
heart attacks, 409–410, 411–412
heart hypertrophy, 346
historical background, 341–342
left bundle branch block diagnosis, 187
microvolt T-wave alternans, 349
and mitral stenosis, 601–602
NIH studies, 349
normal type, 343
for pericarditis, 540
primary arterial hypertension, 544
for pulmonary embolism, 551
right bundle branch block, 185
in syncope diagnosis, 584–585
- Electrolytes, 313
- Electron beam tomography, coronary calcium
evaluation, 593
- Electronic pacing, for atrial fibrillation, 149
- Electrophysiologic testing, in syncope diagnosis, 586
- ELISA, *see* Enzyme-linked immunosorbent assay
- Embolism
definition, 263, 267, 287, 533, 575
pulmonary, *see* Pulmonary embolism
- Embolization, 151
- Embolus, *see* Embolism
- Embryo
definition, 353
heart development, 353–357
- Emotional state, post-heart attack, 420
- Emphysema, in cor pulmonale, 506
- Enalapril
heart failure treatment, 441
for hypertension, 487
- Endarteritis obliterans, 102
- Endocarditis
definition, 251, 359
diagnosis, 359–360
infection sites, 359
infective endocarditis, 463
prevention, 360–361
therapy, 360
- Endocardium, 199, 229, 359
- Endocrine diseases
in erectile dysfunction, 369
and secondary hypertension, 472–473
- Endothelial dysfunction, 293
- Endothelial injury, in atherosclerosis, 121–122
- Endothelial nitric oxide synthase
French red wine, 74
in penile erection, 367
and wine effects, 7
- Endothelin-1 receptor antagonists, 546–547
- Endothelium, 85, 117, 367, 465
- Endovascular stent grafts, for abdominal aortic
aneurysm, 29–30
- eNOS, *see* Endothelial nitric oxide synthase
- Enzyme-linked immunosorbent assay, for pulmonary
embolism, 550–551
- Ephedra sinica*, 454–455
- EPHESUS, *see* Eplerenone post myocardial infarction
and heart failure efficacy and survival study
- Epilepsy
and complete heart block, 526
in loss of consciousness, 215
- Epinephrine
for cardiac arrest, 220
in cardiovascular training, 380
- Epistaxis, 101
- Eplerenone
for African-American heart failure, 556
as diuretic, 317–318
heart failure treatment, 443
and heart hypertrophy, 499
for hypertension, 487
post-heart attacks, 426
- Eplerenone post myocardial infarction and heart
failure efficacy and survival study
for diuretics, 318
heart failure treatment, 443
- EP testing, *see* Electrophysiologic testing
- Eptifibatide, as antiplatelet agent, 82
- ERA, *see* Estrogen Replacement and Atherosclerosis Trial
- Erectile dysfunction
causes, 369
definition, 367
phosphodiesterase inhibitor treatment, 369–370
sildenafil treatment, 370–372
Tadalafil treatment, 372–373
Vardenafil treatment, 372–373
- Esophageal spasm, as heart attack mimic, 406–407
- Estrogen Replacement and Atherosclerosis Trial, 612
- Euroinject, 394
- European International Task Force, 467
- Event recorders, in syncope diagnosis, 585
- Everolimus, in drug-eluting stents, 567
- Exercise
advice for starting, 385–386
as angina treatment, 44
atheroma effects, 381–382
benefits, 375–376

blood effects, 382–383
 blood pressure effects, 381–382
 HDL level variability, 239
 heart disease studies, 383–384
 heart rate during, 386–387
 hypertension treatment, 479
 overview, 385
 post-heart failure, 444–445
 and weight reduction, 381

Exercise stress test
 for angina, 42
 characteristics, 387, 589–590
 men *vs.* women, 610–611
 stress test, 589–590

Eyes, and Marfan syndrome, 505

Ezetimibe
 for cholesterol absorption inhibition, 245
 for dyslipidemia, 325

Ezetrol, *see* Ezetimibe

F

FACIT, *see* Folate therapy after coronary intervention trial

Factor V, oral contraceptive risk, 264

Factor VIII, exercise effects, 382–383

Fainting, in loss of consciousness, 215

Familial hypercholesterolemia, 235–236

Familial predisposition, and atherosclerosis risk, 126

Fats, and cholesterol, 242

FDA, *see* Food and Drug Administration

Feeling of doom, as heart attack warning, 404

Felodipine, as calcium antagonists, 195

Fenfluramine, and coronary artery disease, 310

Fenofibrate
 for cholesterol lowering, 245
 for dyslipidemia, 325

Fetal alcohol syndrome, 507

Fever, from high-altitude pulmonary edema, 9

Feverfew, and cardiovascular disease, 457–458

Fibrates
 for cholesterol lowering, 245
 for dyslipidemia, 325
 for dyslipidemia management, 302

Fibrin, 287

Fibrinolysis, in type 2 diabetes, 299

Fibrosis, aging heart, 2

Fibrous tissue, and atheroma, 37

Finger cuff method, Penaz, 180

Fish oils, and coronary artery disease, 311

Fitness, 375

Flavonoids
 antioxidant effects, 74
 definition, 71, 453

5-Fluorouracil, heart disease induction, 231–232

Fluvastatin, for cholesterol lowering, 244

Foam cells, in atherosclerosis, 122

Folate, for restenosis prevention, 568

Folate therapy after coronary intervention trial, 467–468

Folic acid, and hyperhomocystinemia, 467

Food and beverages, HDL level variability, 238–239

Food and Drug Administration, and abdominal aortic aneurysm treatment, 29–30

Framingham Offspring Cohort, 6

Framingham Point Scores, coronary artery disease risk, 241–242

Framingham Study, obesity and heart disease, 521

Free fatty acids, in type 2 diabetes, 298–299

Free radical, 453

Free radical scavenger
 Danshen as, 454
 definition, 453

French red wine
 antioxidant effects, 74–75
 German white wine comparison, 7

Furosemide
 heart failure treatment, 442
 for hypertension, 486
 as loop diuretic, 316–317

G

Gamma butyrolactone, and athletes, 460–461

Gamma globulin therapy, for Kawasaki syndrome, 502

Garlic, and cardiovascular disease, 456–457

Gemfibrozil
 for cholesterol lowering, 245
 for dyslipidemia, 325

Gene therapy
 adverse outcomes, 394–395
 clinical application, 392–394
 strategies, 391–392

Genetics
 in abdominal aortic aneurysm, 28
 cigarette smoke and atherosclerosis, 337
 dilated cardiomyopathy, 209–210
 Down syndrome, 319
 hemochromatosis, 449
 hypertrophic cardiomyopathy, 204
 type 2 diabetes abnormalities, 299
 in young athlete hypertrophic cardiomyopathy, 133

Genotyping, in cardiomyopathy sudden death, 207

German white wine, French red wine comparison, 7

Giant cell arteritis
 as angina cause, 41
 definition, 501

Ginger, and cardiovascular disease, 457

Ginkgo biloba
 and cardiovascular disease, 455–456
 for high-altitude pulmonary edema, 10

Ginseng, and cardiovascular disease, 457

Global Utilization of Streptokinase and t-PA for Occluded Coronary Arteries, 170

Glyceryl trinitrate, *see* Nitroglycerin
 Good cholesterol, *see* High-density lipoproteins
 Gore-Tex, abdominal aortic aneurysm treatment, 29
 Grafts, coronary artery bypass surgery, 268–269
 Grapefruit, and cardiovascular disease, 460
 Gugulipid, and cardiovascular disease, 458
 GUSTO, *see* Global Utilization of Streptokinase and
 t-PA for Occluded Coronary Arteries
 Gynecomastia, 313

H

Hallmark Scandinavian Simvastatin Survival Study, 234
 Hawthorn, and cardiovascular disease, 458
 HCM, *see* Hypertrophic cardiomyopathy
 Heart attacks, *see also* Myocardial infarction
 acute, 58
 ambulance transport, 407–409
 arm pain mimic, 407
 associated symptoms, 403–405
 beta-blocker treatments, 424–426
 blood tests, 412–413
 caffeine effects, 190
 and cardiac enzymes, 412–413
 causes, 398–400
 chest wall pain mimic, 407
 clinical trials, 405, 417
 depression and anxiety, 420–421
 diet after, 421
 door-to-needle time, 400
 echocardiography, 413
 electrocardiogram, 411–412
 emotional impact, 420
 eplerenone after, 426
 hospital expectations, 409–411
 lung infection mimic, 407
 mimics, 405–407
 overview, 397–398
 pain location, 401–402
 pain management, 413–415
 pain severity and duration, 402–403
 pain types, 400–401
 patient case history, 426–427
 pericarditis mimic, 407
 physical signs, 405
 prevention diet, 428–429
 rehabilitation, retirement, travel, 421–422
 retirement and travel, 423
 risk factors and prevention, 427–428
 sexual activity after, 423–424
 warning attacks, 403
 Heartbeat, origin, 87–88
 Heart block
 aging heart, 2
 bundle branch block, 185–187
 complete heart block, 526–528
 incomplete right bundle branch block, 186
 left anterior hemiblock, 186
 left bundle branch block, 187
 right bundle branch block, 185–186
 Heart damage
 from anthracycline, 229–231
 from carcinoid heart disease, 199
 in hemochromatosis, 450–451
 Heart development
 anomalies, 355–357
 biophysical development, 354
 14 to 18 days, 354
 post-gastrulation, 353
 second month, 354–355
 stages, 355
 10 to 14 days, 353–354
 tube elongation, 355
 Heart and Estrogen/Progestin Replacement Study, 612
 Heart failure
 ACE inhibitors, 63, 440–441
 African-American population, 554–556
 in African-Americans, 554–556
 aging effects, 1
 and alcohol, 6
 aldosterone antagonist treatment, 443
 in angina patients, 53
 angiotensin receptor blocker treatment, 440–442
 artificial heart, 444
 in atrial fibrillation, 142
 basic causes, 434–435
 beta-blocker therapy, 162, 442–443
 cardiac resynchronization therapy, 443–444
 in coronary artery bypass surgery, 271–272
 definition, 1, 5, 25, 27, 35, 61, 105, 139, 153, 159,
 175, 185, 189, 193, 203, 229, 247, 267, 313, 327,
 363, 367, 397, 449, 453, 463, 469, 493, 511, 515,
 519, 539, 543, 553, 559, 597, 599, 609
 diagnosis, 438
 digitalis treatment, 438–439
 digitoxin treatment, 439–440
 discharge from hospital, 445–446
 and diuretics, 313
 diuretic treatment, 442
 echocardiography, 330
 from hypertension, 476–477
 incidence and pathogenesis, 433–434
 in myocardial infarction, 419
 natural defense mechanisms, 436–437
 nitrate treatment, 442
 nondrug therapy, 444–445
 NSAID effects, 517
 and obesity, 521
 precipitating factors, 435–436
 and sleep apnea, 560–562
 symptoms and signs, 437–438
 terminology, 437

- transplantation, 444
- vitamine E role, 73
- Heart hypertrophy
 - in aerobic exercise, 380
 - affecting factors, 495
 - angiotensin II, 494
 - causes and complications, 495
 - compensatory hypertrophy, 493–494
 - concentric hypertrophy, 493
 - definition, 1, 23, 61, 131, 185, 341, 469
 - diagnostic overview, 495–497
 - eccentric hypertrophy, 493
 - electrocardiographic detection, 346
 - left ventricular hypertrophy, 207–208
 - mitochondria, 495
 - prevention and management, 497–499
 - RNA, 494–495
- HeartMate, 107
- Heart murmurs
 - characteristics, 511, 599
 - classification, 513–514
 - clinical cases, 511–512
 - definition, 151, 251, 599
 - diagnostic clues, 512–513
 - investigative tests, 514
- Heart muscle
 - and acromegaly, 363–364
 - aging effects, *see* Aging heart
 - and anemia, 25
 - angina overview, 36–37
 - aortic semilunar valve, 18f
 - arginine role, 85
 - beta-blocker effects, 49
 - caffeine effects, 190
 - chambers, 13, 18–19
 - coronary arteries, 17f, 19–21
 - and Cushing's syndrome, 364
 - definition, 13
 - and depression, 291–292
 - and hyperaldosteronism, 365
 - hypertension effects, 476–477
 - and hypothyroidism, 364
 - internal anatomy, 15f
 - and Marfan syndrome, 505
 - myocardium, 13
 - overview, 13
 - pericardium, 13
 - and pheochromocytoma, 365
 - and pulmonary circulation, 16f
 - as pump, 21
 - rhythm, and alcohol, 7
 - and surrounding structures, 14f
 - systemic veins, 20f
 - and thyrotoxicosis, 364
- Heart Outcomes Prevention Evaluation Trial, 73
- Heart rate
 - caffeine effects, 190
 - as heart attack warning, 404–405
 - maximum during exercise, 386–387
- Heimlich Maneuver, 222
- Helicobacter pylori*, in atherosclerosis, 122
- Hellebore, 459
- Hemochromatosis
 - definition, 449
 - diagnosis, 451
 - genetics, 449
 - incidence, 449
 - iron overload, 449
 - management, 451
 - myocardial damage mechanisms, 450–451
 - signs and symptoms, 451
- Hemodynamics, 117, 203
- Hemorrhage
 - in atheromatous plaques, 127
 - in gene therapy, 395
 - and ginkgo biloba, 455–456
- Hemostatic factors, and alcohol consumption, 6
- Heparins
 - for acute atrial fibrillation, 144
 - blood clot treatment, 173–174
 - in deep vein thrombosis management, 289
 - heart attack therapy, 416
 - low molecular weight heparins, 173, 289–290, 416
 - unfractionated heparin, 173, 416
- Herbal stimulants, in athlete sudden cardiac death, 135
- Herbal supplements
 - and cardiovascular disease, 454–460
 - regulation, 453–454
- HERS, *see* Heart and Estrogen/Progestin Replacement Study
- Heterograft, 251
- Hiatus hernia, as heart attack mimic, 406
- High-altitude pulmonary edema
 - clinical study, 10
 - management, 10
 - mechanisms, 9–10
 - research implications, 10–11
 - signs and symptoms, 9
- High-density lipoproteins
 - and alcohol, 5–6
 - and atherosclerosis, 128
 - atherosclerosis effect, 238
 - blood tests, 241
 - coronary artery disease risk, 242
 - definition, 5
 - exercise effects, 382
 - and hormone therapy, 612
 - level variability, 238–240
 - metabolism, 237–238
 - oral contraceptive risk, 264
 - overview, 237
 - trans fatty acids and CAD, 309
 - in type 2 diabetes, 299

- High thyroid, *see* Hyperthyroidism
- Hippocrates, early disease remedies, 111
- Hirudin, blood clot treatment, 173–174
- HIV, *see* Human immunodeficiency virus
- HMC-CoA reductase inhibitors, for cholesterol lowering, 244–245
- Holter monitor
- definition, 131
 - overview, 590
 - in syncope diagnosis, 584–585
- Holt-Oram syndrome, 507
- Homocysteine
- and atherosclerosis risk, 126
 - benefits of decrease, 467
 - blood levels, 467
 - clinical studies, 465–466, 467–468
 - metabolism, 465
 - and vascular disease, 465
- Homograft
- definition, 251
 - for valve damage, 606
- HOPE Trial, *see* Heart Outcomes Prevention Evaluation Trial
- Hormone therapy, women, 611–612
- Horse chestnut seed, and cardiovascular disease, 458
- Hospitals
- discharge post-heart failure, 445–446
 - heart attack expectations, 409–411
- Human immunodeficiency virus
- and heart, 463
 - in myocarditis, 541
- Hydralazine
- for hypertension, 489
 - pregnancy hypertension, 613
- Hydrochlorothiazide, for hypertension, 486
- Hydrodynamics
- in atherosclerosis, 124–125
 - definition, 117
- Hyperaldosteronism
- and heart, 365
 - and secondary hypertension, 473
- Hypercholesterolemia
- causes, 235–236
 - characteristics, 323–324
 - definition, 5, 321
 - in hyperthyroidism, 598
- Hypercoagulability, 287
- Hyperglycemia, 293
- Hyperglycemic hyperosmolar coma, in elderly type 2 diabetes, 301
- Hyperhomocystinemia
- associated conditions, 466
 - management, 467
 - screening, 466–467
- Hyperkalemia, 61, 215
- Hyperplasia, 101
- Hypertension
- ACE inhibitors, 62–63, 487
 - in African-Americans, 553–554
 - and alcohol, 6, 480
 - alpha-blockers, 489
 - and angina, 53
 - artery and heart effects, 476–477
 - and atrial fibrillation, 140, 142
 - available drugs, 480–482
 - beta-blocker therapy, 161–162, 483–486
 - blood pressure level conventions, 471
 - blood pressure measurement, 469–471
 - brain-acting drugs, 489–490
 - calcium antagonists, 488
 - causes, 471–474
 - and coexisting diseases, 482
 - and coffee, 480
 - in coronary artery bypass surgery, 272
 - definition, 1, 313, 453
 - and diuretics, 313
 - diuretics, 486–487
 - and exercise, 479
 - as heart attack risk factor, 427
 - as heart failure cause, 435
 - and kidney damage, 477
 - malignant hypertension, 473–474
 - nondrug treatment, 478
 - NSAID effects, 517
 - and obesity, 521
 - oral contraceptive risk, 264
 - and organ damage, 482–483
 - overview, 469
 - and pregnancy, 613–614
 - primary essential hypertension, 471–472, 474–475, 475–476
 - primary pulmonary hypertension, 545–546, 546–547
 - pseudohypertension, 179
 - pulmonary arterial hypertension, 543–544, 544–545
 - secondary hypertension, 472–473
 - and sleep apnea, 563
 - and smoking, 480
 - sodium restriction, 478–479
 - and stress, 479
 - and stroke, 477
 - symptoms, 477
 - tests for, 477–478
 - vasodilators, 489
 - and weight reduction, 479
 - white-coat hypertension, 179
- Hypertensive arteriosclerosis, 101
- Hypertensive heart disease
- echocardiography, 332
 - in right bundle branch block, 186
- Hyperthyroidism
- and secondary hypertension, 473
 - signs, symptoms, treatment, 597

- Hypertriglyceridemia
 characteristics, 323
 definition, 321
 in hyperthyroidism, 598
- Hypertrophic cardiomyopathy
 as angina cause, 41
 athlete heart comparison, 136
 beta-blocker therapy, 163
 clinical features, 207
 features, 204
 genetics, 204
 pathophysiology, 207
 sudden death, 207–209
 in young adult sudden cardiac death, 255
 in young athlete sudden cardiac death, 132–134
- Hypocapnia, 549
- Hypoglycemia, 293
- Hypokinesia, 223, 327
- Hypopnea, 559
- Hypotension
 definition, 25, 27, 61, 229, 453, 539, 581
 management, 586
 in syncope, 583
- Hypothyroidism
 and heart, 364
 signs, symptoms, treatment, 597–598
- Hypoxemia, 9, 251
- Hypoxia
 definition, 9, 549
 and high-altitude pulmonary edema, 9–10
 and ventricular fibrillation, 608
- I**
- Iatrogenic, in complete heart block, 528
- Ibutilide, for acute atrial fibrillation, 143
- ICAM-I, *see* Intracellular adhesion molecule-I
- Idiopathic atrial fibrillation, in atrial fibrillation, 143
- Idiopathic degenerative disease, in complete heart block, 527
- Iliac vessels
 and atherosclerosis, 125
 in heart disease, 121
- Imdur, *see* Isorbide mononitrate
- Immobilization, in deep vein thrombosis, 287–288
- Impotence, smoking, 338
- Incomplete right bundle branch block, 186
- Inderal, *see* Propranolol
- Indigestion, as heart attack mimic, 406
- Indo-Mediterranean Diet, coronary artery disease, 308
- Infarct, definition, 61
- Infarction
 cerebral infarction, 576
 definition, 575
 myocardial, *see* Myocardial infarction
- Infection
 in atherosclerosis, 122–124
 in complete heart block, 527
 in coronary artery bypass surgery, 272
 as heart attack mimic, 407
 and mitral valve prolapse, 604
 in pericarditis, 539
 sites in endocarditis, 359
- Infective endocarditis, 463
- Infiltrative diseases, in complete heart block, 527
- Inflammatory response, in atherosclerosis, 121–122
- Inhibited pacemaker, 525
- Injury, during jogging, 385
- iNOS, *see* Nitric oxide synthase
- Inotropic, 193, 433, 453
- Inspra, *see* Eplerenone
- Insulin
 resistance in diabetes type 2, 303
 in type 2 diabetes, 295–297, 298
 for type 2 diabetes management, 299–300
- Integrilin, *see* Eptifibatid
- INTERHEART, smoking study, 337
- Internal mammary arteries, grafts, 269
- International Study of Infarct Survival, 112
- Intima, 27, 101, 117, 565
- Intracellular adhesion molecule-I, 279
- Intracoronary stent, 416–417
- Intracranial hemorrhage, 578
- Irbesartan
 for diabetic nephropathy, 66
 heart failure treatment, 441
- Iron, in hemochromatosis, 449
- Irregular beats, causes and diagnosis, 88–89
- Ischemia
 definition, 25, 57, 85, 117, 159, 229, 251, 327, 341, 367, 391, 575
 and lethal arrhythmias, 399
 myocardial ischemia, 38
 silent ischemia, 53
- Ischemic heart disease, 353
- Ischemic stroke
 causation, 576
 signs and symptoms, 576
- ISIS-2, *see* International Study of Infarct Survival
- Isometric exercise, 380–381
- Isoptin, *see* Verapamil
- Isorbide mononitrate, for angina treatment, 47
- Isordil, *see* Isosorbide dinitrate
- Isosorbide dinitrate, for angina treatment, 46–47
- J**
- Jogging, associated injuries, 385
- K**
- Karyotype, 353
- Kava, and cardiovascular disease, 459

- Kawasaki syndrome
 as angina cause, 41
 causation, 502
 clinical features, 501
 diagnosis, 501–502
 management, 502
 overview, 501
- Kidney, associated physiology, 314–315
- Kidney damage, from hypertension, 477
- Kidney disease
 in edema, 313
 in secondary hypertension, 472
- L**
- Lacidipine
 as calcium antagonist, 197
 for hypertension, 488
- LAD, *see* Left anterior descending coronary arteries
- Lanoxin, *see* Digitalis, digoxin
- Lasix, *see* Furosemide, frusemide
- LBBB, *see* Left bundle branch block
- LDL, *see* Low-density lipoproteins
- Left anterior descending coronary arteries
 grafts, 267
 robotic bypass surgery graft, 269
 visualization, 333
- Left anterior hemiblock, and right bundle branch block, 186
- Left bundle branch block, causes and diagnosis, 187
- Left main coronary artery disease, coronary artery bypass graft, 268
- Left ventricular assist device, 105
- Left ventricular dysfunction, 341, 397, 420, 464, 553
- Left ventricular hypertrophy, 207–208
- Leg arteries, in heart disease, 121
- Lercanidipine
 as calcium antagonist, 197
 for hypertension, 488
- Lesions
 in atherosclerosis, 121
 in paroxysmal atrial fibrillation, 146
 in right bundle branch block, 186
 in Takayasu, 508
- Leukocytes
 in atherosclerosis, 121–122
 definition, 117
- Levitra, *see* Vardenafil
- Licorice, and cardiovascular disease, 459
- Lidocaine, as antiarrhythmic agent, 98
- Lifestyle, causing hyperhomocystinemia, 466
- Light-headedness, as heart attack warning, 404
- Linoleic acid
 and cardiovascular disease, 459
 and cholesterol, 242
- Lionheart, 106–107
- LIPID, *see* Long-Term Intervention with Pravastatin in Ischemic Disease
- Lipid Research Clinics Program, 234
- Lipids
 in atherosclerosis, 122
 garlic effects, 456
 trans fatty acids and CAD, 309–310
- Lipoproteins
 abnormalities, 323–324
 exercise effects, 382
 function, 321
 high-density, *see* High-density lipoproteins
 low-density, *see* Low-density lipoproteins
 particles in atherosclerosis, 121
 size, 321
 types, 321–323
- Lisinopril, heart failure treatment, 441
- Liver disease, in edema, 313
- LMWHs, *see* Low molecular weight heparins
- Long QT syndrome, in athlete sudden cardiac death, 135
- Long-Term Intervention with Pravastatin in Ischemic Disease, as cholesterol study, 235
- Loop diuretics, 316–317
- Lopressor, *see* Metoprolol
- Losartan Heart Failure Survival Study ELITE II, 66
- Loss of consciousness, causes, 215–216
- Lovastatin, 244
- Low-carbohydrate diet, 524
- Low-density lipoproteins
 in atherosclerosis, 122
 blood tests, 240–241
 characteristics, 237
 and coronary artery bypass surgery, 271
 coronary artery disease risk, 241
 and C-reactive protein studies, 280
 exercise effects, 382
 and hormone therapy, 612
 and ischemic stroke, 576
 oral contraceptive risk, 264
 oxidation, 337
 and TIA management, 578
 trans fatty acids and CAD, 309
 in type 2 diabetes, 299
- Low-fat diet, 524
- Low molecular weight heparins
 blood clot treatment, 173
 for deep vein thrombosis management, 289–290
 heart attack therapy, 416
- Low thyroid, *see* Hypothyroidism
- Lung diseases, in cor pulmonale, 506
- Lung infection, as heart attack mimic, 407
- Lungs, beta-blocker effects, 49
- Lung scan, for pulmonary embolism, 551
- Lung transplantation, for primary pulmonary hypertension, 547
- Lupus, 77, 508
- Lyon Diet Heart Study, coronary artery disease, 308

M

- Macrophage-colony stimulating factor,
in atherosclerosis, 122
- Macrovascular damage, 293
- Macula densa, 61
- Magnesium sulfate, for cardiac arrest, 221
- Magnetic resonance angiography
clinical studies, 594
overview, 593–594
- Magnetic resonance imaging, for aortic dissection, 32
- Ma Huang, *see Ephedra sinica*
- Malignant hypertension, causes, 473–474
- Malignant tumor, 199
- Manidipine
as calcium antagonist, 197
for hypertension, 488
- Marfan syndrome
beta-blocker therapy, 163
symptoms and management, 505
- Maturity onset diabetes of the young, 299
- Maximal oxygen consumption, 375
- MCP-1, *see* Monocyte chemoattractant protein-1
- M-CSE, *see* Macrophage-colony stimulating factor
- Mechanical heart valves, 604
- Media, 27, 61, 101
- Medications, causing hyperhomocystinemia, 466
- Mediterranean diet
antioxidant effects, 74
for coronary artery disease, 307–308
- Men, women's heart comparison, 610–611
- Menopause, and cardiac disease protection, 611–612
- MERIT-HF trial, heart failure treatment, 442–443
- Messenger ribonucleic acid, and wine effects, 7
- Metabolic syndrome, and obesity, 519
- Metastases, 229
- Methyl dopa
for hypertension, 489–490
pregnancy hypertension, 613
- Metoprolol
for angina treatment, 50
as beta-blocker, 166
for hypertension, 485
post-heart attacks, 425
- Metropolitan height and weight tables, and obesity, 519
- Mexiletine, as antiarrhythmic agent, 98
- Microvascular damage, 293
- Microvolt T-wave alternans, 349
- Mitochondria
definition, 375
in hypertrophy, 495
- Mitral regurgitation
beta-blocker therapy, 162–163
characteristics, 602
definition, 327
echocardiography, 329
- Mitral stenosis
beta-blocker therapy, 162–163
characteristics, 601–602
echocardiography, 329
and pregnancy, 614
- Mitral valve disease, echocardiography, 329
- Mitral valve prolapse
in athlete sudden cardiac death, 135
characteristics, 604
- Mobile coronary care ambulance, post-heart
attack, 408–409
- Moduretic, for hypertension, 486
- MODY, *see* Maturity onset diabetes of the young
- Monckeberg's sclerosis, in arteriosclerosis, 102
- Monitan, *see* Acebutolol
- Monocyte chemoattractant protein-1, 122
- Monocytes, 117
- Morbidity
in coronary artery bypass surgery, 271
reduction in heart attack, 415
- Morphine, for heart attack pain, 413–414
- Mortality
in coronary artery bypass surgery, 271
reduction in heart attack, 415
- MRI, *see* Magnetic resonance imaging
- mRNA, *see* Messenger ribonucleic acid
- Muscular system, beta-blocker effects, 49
- Mutations, 203
- MYH7, *see* Beta myosin heavy chain gene
- Myocardial infarction, *see also* Heart attacks
acute, *see* Acute myocardial infarction
beta-blocker therapy, 161
bradyarrhythmia complications, 419
and catecholamine, 398–399
in complete heart block, 527
and coronary arteries, 20
definition, 1, 13, 35, 57, 61, 71, 79, 87, 111, 117, 139,
159, 169, 175, 185, 193, 201, 215, 227, 233, 251,
263, 267, 277, 307, 321, 327, 335, 341, 363, 367,
375, 391, 433, 453, 465, 469, 493, 501, 515, 519,
539, 559, 569, 589, 607, 609
heart failure complications, 419
from hypertension, 476
non-ST elevation, 417–418
oral contraceptive risk, 264
papillary rupture, 399
right ventricular infarction complications,
419–420
risk assessment, 420
tachyarrhythmia complications, 418–419
- Myocardial ischemia, process, 38
- Myocarditis
and AIDS, 464
in athlete sudden cardiac death, 134–135
causes, signs, management, 541
definition, 463

- Myocardium
 definition, 1, 13, 25, 35, 57, 87, 131, 153, 223, 341, 353, 363, 391, 449
 as heart component, 13
- Myocytes, 193
- Myofibrillar ATPase, in heart hypertrophy, 495
- Myopathy, 281
- Myopericarditis, 229
- Myosin, in heart hypertrophy, 495
- Myotonic muscular dystrophy, 508
- Myxedema, *see* Hypothyroidism
- N**
- Nadolol
 for angina treatment, 50
 for hypertension, 485
- National Cholesterol Education Program, 241–242
- National Institutes of Health, ECG studies, 349
- Natural products, and cardiovascular disease, 460
- Nausea, as heart attack warning, 404
- NCEP, *see* National Cholesterol Education Program
- Nebivolol, as beta-blocker, 166
- Necrotic, definition, 61, 229
- Nephropathy
 definition, 61
 types II diabetes, 66
- Nervous system, beta-blocker effects, 49
- Neurally mediated syncope, 586
- Neurologic, in coronary artery bypass surgery, 272
- Neuromuscular disease, in complete heart block, 527
- Neutrophils, 9
- New York Heart Association, heart failure definition, 105, 438
- Niacin, for cholesterol lowering, 245
- Nicorandil, for angina treatment, 52
- Nicotine
 and blood clots, 170
 as cigarette smoke component, 336
- Nicotinic acid, *see* Niacin
- Nifedipine
 as calcium antagonist, 195
 for high-altitude pulmonary edema, 10
 for hypertension, 488
- Nitrates
 for angina treatment, 45–47
 for heart failure, 419
 heart failure treatment, 442
- Nitric oxide
 and ACE inhibitors, 62
 and vasodilatory function, 337
- Nitric oxide synthase, and cardiogenic shock, 202
- Nitroglycerin
 for angina treatment, 45–46
 for heart attack pain, 415
- NO, *see* Nitric oxide
- Nonrapid eye movement, cardiovascular system effects, 559
- Non-ST elevation myocardial infarction, 417–418
- Nonsteroidal anti-inflammatory drugs
 atherothrombosis effect, 516
 cardiovascular effects, 515–517
 cautions, 517
 cyclooxygenase effects, 80
 and heart failure, 517
 and hypertension, 517
 mechanism of action, 112
 overview, 515
 prostacyclin effects, 516
 viral load effects, 516–517
- Noonan syndrome, 506–507
- Noradrenaline, from stress, 569–571
- Norepinephrine, in cardiovascular training, 380
- Norvasc, *see* Amlodipine
- Norwegian Postinfarction Timolol Trial, 163–164
- Nosocomial, 359
- Novacor, as artificial heart device, 107
- NREM, *see* Nonrapid eye movement
- NSAIDs, *see* Nonsteroidal anti-inflammatory drugs
- Nuclear scans
 for heart disease, 590–591
 men *vs.* women, 610–611
- Numbness, as heart attack mimic, 407
- O**
- Obesity
 and African-American hypertension, 554
 Atkins-type diet, 523–524
 cardiovascular system effects, 521
 diet comparison, 524
 HDL level variability, 239
 incidence, 519
 management, 521–523
 treatment recommendations, 524
- Obstructive sleep apnea, 560
- Oligohydramnios, 251
- Oral agents, antiplatelet activity, 83
- Oral anticoagulants, blood clot treatment, 172–173
- Oral contraceptives
 coagulation factor effects, 263
 deep vein thrombosis, 264
 hypertension, 264
 myocardial infarction, 264
 research studies, 264–265
 risks, 263
- Organ damage, and hypertension therapy, 482–483
- Orthostatic hypotension
 management, 586
 in syncope, 583
- OSA, *see* Obstructive sleep apnea
- Outflow tract gradient, 203

- Oxidation, LDL, 337
- Oxygen
 in cardiovascular training, 378–380
 for heart attack pain, 415
- Oxygen consumption, in aerobic exercise, 376
- P**
- Pacemakers
 for atrial fibrillation, 149
 for complete heart block, 526–528
 conditions not used for, 532
 electrical safety, 530
 general complications, 530–531
 historical overview, 525–526
 malfunction, 531
 patient activities, 532
 for sinus node dysfunction, 528–529
 temporary pacing, 531–532
 types, 529–530
- Pacemaker syndrome, 531
- Paclitaxel-eluting stent, 567
- Paget's disease, 507
- PAH, *see* Pulmonary arterial hypertension
- Pain
 in angina, 38–39, 337–338
 angina diagnosis, 39–40
 chest, men *vs.* women, 610–611
 as heart attack mimic, 407
 heart attacks, 400–403, 413–415
- Palpitations
 causes and diagnosis, 88–89
 definition, 35, 69
- Panax ginseng*, *see* Ginseng
- Paroxysmal atrial fibrillation, 145–146
- Paroxysmal atrial tachycardia, 90
- Paroxysmal nocturnal dyspnea, 203
- Partial thromboplastin time, oral contraceptive risk, 263
- Patent ductus arteriosus, in CHD, 253–254
- Patent foramen ovale
 clinical features, 535
 developmental features, 533–535
 research implications, 537
 in stroke, 535–537
- Pathogenesis, 117
- Pausinystalia yohimbe*, *see* Yohimbine
- PCI, *see* Percutaneous coronary intervention
- PCI CURE, for Clopidogrel, 81
- Penile erection, associated physiology, 367–369
- Percutaneous coronary intervention
 beta-blocker therapy, 162
 coronary bypass surgery, 274–275
 in coronary care unit, 411
 definition, 79, 169
 in heart attack clinical trials, 417
 and stents, 565
- Percutaneous intervention, in elderly, 2
- Percutaneous transluminal coronary angioplasty
 contraindications and limitations, 58–59
 outcome, 59
 procedure, 57–58
 and restenosis, 566
 and stents, 565
- Pericardial effusion
 and AIDS, 463–464
 definition, 463
- Pericarditis
 causes, 539
 definition, 341, 539
 diagnosis, 539–540
 as heart attack mimic, 407
 types, 540–541
- Pericardium
 definition, 463
 as heart component, 13
- Perioperative mortality, beta-blocker therapy, 163
- Peripartum cardiomyopathy, and pregnancy, 614
- Permanent atrial fibrillation, 148
- Persistent atrial fibrillation, 147–148
- PET, *see* Positron emission tomography
- Phentermine, and coronary artery disease, 310
- Phenylalkylamines, as calcium antagonist, 195–196
- Pheochromocytoma
 and heart, 365
 and secondary hypertension, 473
- Phlebitis, 287
- Phosphodiesterase inhibitors
 for erectile dysfunction, 369–370
 for primary pulmonary hypertension, 547
- Pindolol, for hypertension, 485
- Piper methysticum, *see* Kava
- PKC, *see* Protein kinase C
- Plaques
 atheromatous plaques, 37, 52, 127, 170, 227
 atherosclerotic, and angiogenesis, 126
- Platelet aggregation, 453, 607
- Platelet glycoprotein IIb/IIIa receptor blockers
 blood clot treatment, 172
 for non-ST elevation myocardial infarction, 418
 types, 82–83
- Platelets
 in blood clots, 169
 cigarette smoke and atherosclerosis, 337
 definition, 77, 79, 111, 117, 169, 569
- Plendil, *see* Felodipine
- Polygenic hypercholesterolemia, 236
- Polypharmacy, aging heart research, 3
- Polyphenols, in wine comparison, 7
- Polyunsaturates, and cholesterol, 242
- Population groups, HDL level variability, 238
- Positron emission tomography, as heart disease test, 590

- Potassium, post-heart failure, 444–445
- Potassium-sparing diuretics, 317–318
- PPH, *see* Primary pulmonary hypertension
- Prague-2 trial, for heart attacks, 417
- Pravastatin, for cholesterol lowering, 244
- Prazosin, for hypertension, 489
- Prednisone, for restenosis prevention, 568
- Pregnancy
 - and arrhythmias, 614
 - and congenital heart disease, 258, 261
 - heart disease overview, 612–613
 - and hypertension, 613–614
 - and peripartum cardiomyopathy, 614
 - and valvular heart disease, 614
- Preload
 - definition, 35, 159, 397, 581
 - in vasovagal syncope, 582
- Premature beats, causes and diagnosis, 88–89
- Primary essential hypertension
 - causes, 471–472, 475–476
 - salt hypothesis, 474–475
- Primary pulmonary hypertension
 - diagnosis, 545
 - risk factors, 545–546
 - therapy, 546–547
- Prinivil, *see* Lisinopril
- Prinzmetal's angina, 53–54
- Probuco, antioxidant effects, 75
- Procainamide, as antiarrhythmic agent, 98–99
- Procardia, *see* Nifedipine
- Procardia XL, *see* Nifedipine
- Prophylaxis
 - in deep vein thrombosis management, 289–290
 - definition, 287
- Propranolol
 - as beta-blocker, 166–167
 - for angina treatment, 50
 - for hypertension, 483–484
 - post-heart attacks, 425
- Prostacyclin
 - NSAID effects, 516
 - for primary pulmonary hypertension, 546
- Prostaglandin endoperoxidase H synthase inhibitors, 515
- Prosthetic valve
 - choices, 604–606
 - murmurs, 514
- Protein kinase C, and diabetes vascular abnormalities, 298
- Proteinuria, 61
- Proximal, 287
- Pseudohypertension, in blood pressure variability, 179
- Pseudoxanthoma elasticum, 507–508
- PTCA, *see* Percutaneous transluminal coronary angioplasty
- PTT, *see* Partial thromboplastin time
- Pulmonary angiogram, for embolism, 551
- Pulmonary arterial hypertension
 - laboratory studies, 544–545
 - risk factors, 543
 - signs and symptoms, 543–544
- Pulmonary arteries
 - and atherosclerosis, 125
 - in heart disease, 121
- Pulmonary circulation, and heart anatomy, 16
- Pulmonary edema
 - definition, 9, 157, 159, 193, 247
 - high-altitude, *see* High-altitude pulmonary edema
- Pulmonary embolism
 - diagnosis, 550
 - incidence, 549
 - investigations, 550–551
 - management, 551
 - pathogenesis, 549
 - pathophysiology, 549–550
- Pulmonary vein ablation, in paroxysmal atrial fibrillation, 146
- Pulsatile blood flow, in atherosclerosis, 124–125
- Pulse, in CPR, 217
- Purkinje fibers, 87
- Purple grape juice
 - antioxidant studies, 74
 - and cardiovascular disease, 460
- ## Q
- QT syndrome
 - acute atrial fibrillation, 143–144
 - beta-blocker therapy, 163
- Quinidine, as antiarrhythmic agent, 99–100
- ## R
- RAAS, *see* Renin angiotensin aldosterone system
- Race
 - and coronary artery disease, 556–557
 - and heart failure, 554–556
 - and hypertension, 553–554
 - and stroke, 556–557
- Radial arteries, grafts, 269
- Radiation, in pericarditis, 539
- Ramipril, for hypertension, 487
- Ranolazine, for angina treatment, 52–53
- RAVE, *see* Regional angiogenesis with vascular endothelial growth factor in peripheral arterial disease
- RAVEL study
 - and restenosis, 566
 - for sirolimus-eluting stents, 566
- RBBB, *see* Right bundle branch block
- Reactive oxygen species, in atherosclerosis, 124–125
- Red wine, white wine comparison, 7–8
- Reflex-mediated syncope
 - carotid sinus hypersensitivity, 583
 - vasovagal syncope, 581–583
- Reflux esophagitis, as heart attack mimic, 406

- Regional angiogenesis with vascular endothelial growth factor in peripheral arterial disease, 394
- Renal arteries, in heart disease, 121
- Renin angiotensin aldosterone system, 494
- Renin inhibitor, for hypertension, 490
- Renoprotection, 469
- ReoPro, *see* Abciximab
- Resins, for cholesterol lowering, 245
- Resistance exercise, isometric exercise comparison, 380
- Responsiveness, CPR steps, 217
- Restenosis
 - overview, 565–566
 - as PTCA limitation, 59
- Restlessness, as heart attack warning, 404
- Restrictive cardiomyopathy, 211
- Retinopathy, 101
- Revascularization, 201
- REVERSAL, *see* Reversing atherosclerosis with aggressive lipid-lowering
- Reversing atherosclerosis with aggressive lipid-lowering, 128
- Rhabdomyolysis, 281
- Rheumatic fever, in valve damage, 600–601
- Right bundle branch block, 185–186
- Right heart failure, 435
- Right ventricular infarction, 419–420
- Risk assessment
 - angina, 54
 - atherosclerosis, 126
 - for atrial fibrillation, 141f
 - cholesterol and coronary artery disease, 241–242
 - coffee and type 2 diabetes, 302–303
 - C-reactive protein as marker, 277–278
 - heart attacks, 427–428
 - myocardial infarction, 420
 - nuts and cholesterol, 243
 - obstructive sleep apnea, 560
 - oral contraceptives, 263–264
 - prevention with aspirin, 113–114
 - primary arterial hypertension, 543
 - primary pulmonary hypertension, 545–546
 - vigorous exercise, 384–385
- Risk of death, in young athlete hypertrophic cardiomyopathy, 133–134
- Riva-Rocci sleeve, 177–178
- RNA, and hypertrophy, 494–495
- Robotic bypass surgery, LAD graft, 269
- ROS, *see* Reactive oxygen species
- Rosuvastatin
 - for cholesterol lowering, 245
 - for dyslipidemia, 325
- Rubella syndrome, 507
- S**
- S. aureus*, in endocarditis, 360
- S. bovis*, in endocarditis, 360
- S. durans*, in endocarditis, 360
- S. fecalis*, in endocarditis, 360
- S. fecium*, in endocarditis, 360
- S. viridans*, in endocarditis, 360
- S1, definition, 511
- S2, definition, 511
- Salmeterol, for high-altitude pulmonary edema, 10
- Salt
 - post-heart failure, 444–445
 - in primary essential hypertension, 474–475
 - restriction in hypertension, 478–479
- Salvia miltiorrhiza*, *see* Danshen
- SA node, *see* Sinoatrial node
- Saphenous vein, grafts, 268–269
- Sarcoidosis, 509
- Sarcomere, 131, 203, 493
- Saturated fats
 - and cholesterol, 242
 - and obesity, 522
- Scandinavian Simvastatin Survival Study, 324–325
- SCD, *see* Sudden cardiac death
- Secondary hypertension, 472–473
- Secondary Prevention and Antioxidants of Cardiovascular Disease in End-Stage Renal Disease, 72
- Sectral, *see* Acebutolol
- Seizure, in loss of consciousness, 215
- Selective serotonin reuptake inhibitors, 291–292
- Seven Countries Study, cholesterol, 234
- Severe anemia, as angina cause, 41
- Sexual activity, post-heart attack, 423–424
- SHOCK trial, for cardiogenic shock, 202
- Shortness of breath
 - in aortic stenosis, 603
 - as heart attack warning, 404
 - from high-altitude pulmonary edema, 9
- Sick sinus syndrome
 - aging heart, 2
 - in atrial fibrillation, 142
- Sildenafil, for erectile dysfunction, 370–372
- Silent ischemia, and angina, 53
- Simvastatin, for cholesterol lowering, 245
- Single photon emission computerized tomography, 590
- Sinoatrial node, and calcium antagonists, 194
- Sinus node dysfunction, 528–529
- Sinus tachycardia, 90
- SIRIUS trial, for sirolimus-eluting stents, 566
- Sirolimus-eluting stents, 566
- Skeleton, and Marfan syndrome, 505
- Sleep, cardiovascular effects, 559
- Sleep apneas
 - and arrhythmias, 563
 - and atrial pacing, 562
 - and heart failure, 560–562
 - and hypertension, 563
 - overview, 559–560

- Smoking, *see also* Cigarette smoking
in abdominal aortic aneurysm, 27–28
angina effects, 44
anginal pain, 337–338
habituation and cessation, 338
and hypertension, 480
impotence, 338
- Smooth muscle cells
in atherosclerosis, 122
definition, 565
- Sodium bicarbonate, for cardiac arrest, 221
- Sodium cardiac channels, 183
- Sodium restriction, hypertension treatment, 478–479
- Sotalol
as antiarrhythmic agent, 96–97
as beta-blocker, 167
- SPACE study, *see* Secondary Prevention and Antioxidants of Cardiovascular Disease in End-Stage Renal Disease
- Specific heart muscle disease, 211–212
- SPECT, *see* Single photon emission computerized tomography
- Sphygmomanometry
blood pressure measurement, 469–470
historical overview, 175
- Spironolactone
for African-American heart failure, 556
as diuretic, 317
heart failure treatment, 443
and heart hypertrophy, 498–499
- SPORTIF, for atrial fibrillation, 149
- Sports, and stress, 571
- SSRIs, *see* Selective serotonin reuptake inhibitors
- St. John's wort, 459
- Stable angina
aspirin treatment, 113
coronary artery bypass graft, 268
- Static exercise, *see* Isometric exercise
- Statins
for angina treatment, 52
characteristics, 71
for cholesterol lowering, 244–245
coronary artery bypass surgery, 273
cytochrome P-450 interactions, 283, 285
for dyslipidemia, 301–302, 324–325
for primary pulmonary hypertension, 547
- Stent restenosis study, 565
- Stents
as cardiology advance, 565
drug-eluting, *see* Drug-eluting stents
heart attack therapy, 416–417
long-term studies, 567–568
- Stokes-Adams syndrome
and complete heart block, 526
and ventricular fibrillation, 608
- Stomach problems, as heart attack mimic, 406
- Streptokinase
blood clot treatment, 170–171
heart attack therapy, 416
- STRESS, *see* Stent restenosis study
- Stress
and atherosclerosis risk, 126
cardiovascular system effects, 569–571
definition, 569
how to handle, 572
and hypertension, 479
signs and symptoms, 571–572
and sports, 571
testing in syncope diagnosis, 586
and type A behavior, 572
- Stroke
in African-Americans, 556
and alcohol, 7
from hypertension, 477
in loss of consciousness, 215–216
patent foramen ovale role, 535–537
- Subarachnoid hemorrhage, 578
- Subclavian steal syndrome, in syncope, 584
- Sudden cardiac death
athletes
aortic stenosis, 134
commotio cordis, 135
coronary artery anomalies, 134
coronary artery disease, 134
from hypertrophic cardiomyopathy, 132–134
overview, 131–132
ruptured aorta, 134
various causes, 134–135
definition, 131, 185, 493
in hypertrophic cardiomyopathy, 207–209
and vigorous exercise, 384–385
in young adults, 255
- Supplements
and cardiovascular disease, 454–460
regulation, 453–454
- Supraventricular tachcardia, 581
- Surgery, for abdominal aortic aneurysm, 29
- Surgical management, aortic dissection, 32
- Surgical myomectomy, in cardiomyopathy sudden death, 209
- Survival, coronary artery bypass graft, 270
- Sweating, as heart attack warning, 403
- Swedish angina pectoris aspirin trial, 112
- Sympathomimetic, 453
- Synchronized DC conversion, for persistent atrial fibrillation, 147–148
- Syncope
cardiac causes, 587
from cardiac disorders, 583–584
causes, 581
definition, 27, 131, 183, 215, 251, 463, 543, 581
diagnostic evaluation, 584–586
in loss of consciousness, 215

management, 586–587
 from orthostatic hypotension, 583
 reflex-mediated syncope, 581–583
 unexplained types, 587

Syndrome X, as angina cause, 41

Syphilis, 30, 509

Systemic veins, anatomy, 20f

Systole, 159

Systolic blood pressure, 178

Systolic heart murmurs, 513–514

T

Tachyarrhythmias
 in myocardial infarction, 418–419
 in syncope, 584, 587

Tachycardia
 characteristics, 89
 definition, 35, 139, 363

Tachypnea, 543, 549

Tadalafil, erectile dysfunction treatment, 372–373

Takayasu, lesions and management, 508

Tanacetum parthenium, *see* Feverfew

Tar fraction, in cigarette smoke, 337

TEE, *see* Transesophageal echocardiography

Tenecteplase
 blood clot treatment, 171
 heart attack therapy, 416

Tenormin, *see* Atenolol

Teratogens
 and CHD in pregnancy, 258, 261
 and heart development, 356

Terazosin, for hypertension, 489

TET, *see* Transcutaneous energy transfer

Tetralogy of Fallot, 256–258

Thiazides, as diuretics, 315–316

Thiazolidinediones, for type 2 diabetes management, 301

Thoracic aortic aneurysm, 30–31

Thoratec, as artificial heart device, 107

Thrombin inhibitors, blood clot treatment, 173–174

Thromboangiitis obliterans, in arteriosclerosis, 102

Thrombocythemia, 549

Thrombocytopenia, 77

Thromboembolism, 105, 263

Thrombogenic, definition, 117

Thrombolytic therapy
 for blood clots, 170–171
 in elderly, 2
 for heart attacks, 415–416

Thrombosis, in type 2 diabetes, 299

Thrombotic factors, cigarette smoke and atherosclerosis, 337

Thrombus
 definition, 79, 287
 echocardiography, 329

Thyroid diseases, and heart, 364

Thyroid dysfunction, types and characteristics, 597–598

Thyrotoxicosis
 in atrial fibrillation, 143
 and heart, 364

TIA, *see* Transient ischemic attack

Tiazac, *see* Diltiazem

Ticlopidine
 blood clot treatment, 172
 Clopidogrel comparison, 82

Tilt-table testing, in syncope diagnosis, 586

Timolol
 for hypertension, 485–486
 post-heart attacks, 425

Tingling, as heart attack mimic, 407

Tirofiban, as antiplatelet agent, 82–83

Tissues, 13, 201

TNNT2, *see* Cardiac troponin-T

Toprol XL, *see* Metoprolol

Torcetrapib, for dyslipidemia, 302, 326

Torsades de Pointes, 95, 139

Total cholesterol
 blood tests, 240
 characteristics, 237
 coronary artery disease risk, 242

t-PA, *see* Alteplase

Transcutaneous energy transfer, AbioCor, 106

Transesophageal echocardiography
 for aortic dissection, 31
 for endocarditis, 360
 and mitral stenosis, 602
 overview, 329
 patent foramen ovale, 533–534

Trans fatty acids, and coronary artery disease, 308–310

Transient ischemic attack
 definition, 533
 management, 577–578
 outcome, 577
 prevention with aspirin, 114
 signs and symptoms, 577
 in syncope, 586–587

Transplantation
 lung transplantation, 547
 post-heart failure, 444
 type 1 diabetes studies, 305

Transthoracic echocardiogram, 329

Transthoracic visualizations, coronary artery, 333

Transvenous, 525

Triamterene, as diuretic, 317

Tricuspid regurgitation, 199

Turner syndrome, 507

T wave alternans, in myocardial infarction, 420

Type A behavior, and stress, 572

U

Ubiquinone, *see* Coenzyme Q10

UKPDS, for beta-blockers, 164

- Ultrasonography
 in deep vein thrombosis diagnosis, 289
 for echocardiography, 328
 for pulmonary embolism, 551
- Unfractionated heparin
 blood clot treatment, 173
 heart attack therapy, 416
- Unstable angina
 aspirin treatment, 113
 characteristics and treatment, 54–55
 coronary artery bypass graft, 268
 definition, 277
- Upper limb arteries, and atherosclerosis, 125
- Urgent medical management, aortic dissection, 32
- Urine tests, for hypertension, 477–478
- V**
- VAD, *see* Ventricular assist device
- Vagus nerve, in cardiovascular training, 378
- Valve damage, from rheumatic fever, 600–601
- Valve diseases
 causes and consequences, 599–600
 prosthetic valve choice, 604–606
- Valve disorders, 139, 584
- Valve lesions
 aortic regurgitation, 603–604
 aortic stenosis, 602–603
 mitral regurgitation, 602
 mitral stenosis, 601–602
 mitral valve prolapse, 604
- Valvotomy, and mitral stenosis, 602
- Valvular, definition, 23
- Valvular heart disease
 in atrial fibrillation, 142
 definition, 581
 echocardiography, 329
 as heart failure cause, 435
 and pregnancy, 614
- Valvular lesions, in right bundle branch block, 186
- Valvuloplasty, and mitral stenosis, 602
- Vardenafil, erectile dysfunction treatment, 372–373
- Variant angina, disease cause, 40
- Vascular cell adhesion molecule-1, 121–122
- Vascular disease, and homocysteine, 465
- Vascular system, aging effects, 1–2
- Vasculitis, *see* Giant cell arteritis
- Vasoconstriction, 453
- Vasodepressors, in vasovagal syncope, 582
- Vasodilation, and nitric oxide, 337
- Vasodilators, for hypertension, 489
- Vasodilatory, definition, 293
- Vasopressin, 220
- Vasotec, *see* Enalapril
- Vasovagal syncope
 mechanisms, 582
 overview, 581–582
 triggers, 582–583
- VCAM-1, *see* Vascular cell adhesion molecule-1
- Veins
 and atherosclerosis, 125
 pulmonary vein ablation, 146
 saphenous vein, 268–269
 systemic veins, 20
- Venodilatation, 397
- Venography, in deep vein thrombosis diagnosis, 289
- Venous ultrasonography, for pulmonary embolism, 551
- Ventricular assist device, 107–109
- Ventricular cavity, 131
- Ventricular dysfunction, 463
- Ventricular fibrillation
 clinical features, 607
 and CPR, 216
 definition, 87, 131, 159, 183, 215, 375
 genesis and causes, 607–608
 management, 608
- Ventricular premature beats
 beta-blocker treatments, 96
 diagnosis, 89
- Ventricular septal defects
 as congenital heart disease, 252–253
 definition, 319
 and tetralogy of Fallot, 256–257
- Ventricular tachycardia
 characteristics, 93–95
 and CPR, 216
- Verapamil
 as angina treatment, 51
 as calcium antagonist, 195–196
 for hypertension, 488
- Veratrum, *see* Hellebore
- Very-low-density lipoproteins, 240
- Vessels
 and atherosclerosis, 125
 beta-blocker effects, 49
 caffeine effects, 190
- VF, *see* Ventricular fibrillation
- Vigorous exercise, risk, 384–385
- Viral infections, in pericarditis, 539
- Viral load, NSAID effects, 516–517
- Viral pericarditis, 540
- Visceral adiposity, 293
- VISIP, *see* Vitamin Intervention for Stroke Prevention
- Vitamin C, antioxidant effects, 73
- Vitamin E, clinical studies, 72–73
- Vitamin Intervention for Stroke Prevention, 126, 468
- Vitamin supplements, regulation, 453–454
- VLDL, *see* Very-low-density lipoproteins
- Vomiting, as heart attack warning, 404
- VPBs, *see* Ventricular premature beats
- VSDs, *see* Ventricular septal defects
- VT, *see* Ventricular tachycardia

W

- Wall tension, 27
- Warfarin
for atrial fibrillation, 148
blood clot treatment, 172–173
- Weakness, as heart attack warning, 404
- Weight reduction
as angina treatment, 42–44
and exercise, 381
hypertension treatment, 479
and obesity, 521–523
- West of Scotland Coronary Prevention Study, 234–235
- WHI, *see* Woman's Health Initiative Study
- White-coat hypertension, in blood pressure variability, 179
- White wine, red wine comparison, 7–8
- Wine, consumption comparison, 7–8
- Wolff-Parkinson-White syndrome
in acute atrial fibrillation, 145
in athlete sudden cardiac death, 135
characteristics, 93
definition, 139, 607
and ventricular fibrillation, 608
- Woman's Health Initiative Study, 612
- Women
acute myocardial infarction, 611
dyslipidemia, 611
heart disease statistics, 609–610
hormone therapy, 611–612
men's heart comparison, 610–611
pregnant, *see* Pregnancy
and testing technology, 611
- Work, in aerobic exercise, 377–378
- WPW, *see* Wolff-Parkinson-White syndrome

X

- Xenobiotic, 281
- Ximelagatran
for atrial fibrillation, 148–149
blood clot treatment, 173–174
- X-ray, *see* Chest X-ray

Y

- Yohimbine, and cardiovascular disease, 459–460

Z

- Zestril, *see* Lisinopril
- Zetia, *see* Ezetimibe
- Zingiber officinale*, *see* Ginger

