

FINE ARTS LIBRARY



FL 14XU I



J A P A N

ITS ARCHITECTURE, ART, AND  
ART MANUFACTURES



# JAPAN

## ITS ARCHITECTURE, ART, AND ART MANUFACTURES

BY

CHRISTOPHER DRESSER

PH.D., F.L.S., ETC.



LONDON  
LONGMANS, GREEN, AND CO.

NEW YORK  
SCRIBNER AND WELFORD

1882

A-04

N7350

. D7

## P R E F A C E.

AN apology is needed for adding to the number of our books on Japan. We have heard of the ways of the Japanese, of the peculiarities of their manners, of their feasts and festivals, of the food they eat, and of the aspect of the country in which they live. My excuse for writing is a simple one—I am a specialist.

An architect and ornamentist by profession, and having knowledge of many manufacturing processes, I went to Japan to observe what an ordinary visitor would naturally pass unnoticed. As a specialist, and a specialist only, I submit this volume to public notice. When in Japan I engaged the best native photographer that I could find to take views for me ; thus I got not only architectural edifices, but also architectural details. I also engaged the best ornamentist in Kioto to make coloured drawings of temple decorations for me.

Many will be surprised when I say that as yet the English public know almost nothing, and even our architects very little, of Japanese architecture. Coloured illustrations are needed to give anything like a complete idea of the glories of Buddhistic art ; yet I hope that my book may throw some little light on Japanese building, and do something towards revealing the fact that Japan has had a great architectural history, although I have no chromatic illustrations. Ornament springs from architecture. I

have therefore endeavoured to trace its origin and development ; and for the first time, so far as I know, the growth of native conventional ornament is brought before the English reader.

Drawings of flowers, of birds, of fish, of insects, are all familiar to us ; but it is not generally known that just as the Greeks, Moors, and other peoples associated with their architecture certain conventional forms, so the Japanese have a national style of conventional ornament ; yet this is the case. To me the fact was almost unknown up to the time that I visited the country, although I had been an earnest student of Oriental art for nearly thirty years.

In my book I attempt to explain how the architecture resulted from climatic and religious influences, and how the ornaments with which domestic objects are figured, and the very finish of the objects themselves, are traceable to religious teachings.

As a guest of the nation, I was not only permitted to enter sacred edifices (some of which had never before been trodden by European feet), but I had also opportunities for studying all forms of art industry. For the privileges enjoyed I shall ever feel under a debt of gratitude to the members of the Japanese Government. I had also the honour of presentation to His Majesty the Mikado, who himself ordered that I should have every facility for seeing what I wished.

While in Japan I made a daily record of what I saw and did ; and this record was roughly illustrated. I either bought or had taken for me about a thousand photographs, some being fifteen inches by eighteen, the others about nine inches by twelve. I had a multitude of small coloured drawings made of temple ornaments. I visited sixty-eight potteries, and some scores of manufacturers engaged in other industries. I also brought specimens of work from most of the factories visited.

As to the temples and shrines, I saw about a hundred of the finest in the country, to say nothing of the crowd of temples

nestled together on the top of Mount Koya-zan, many of which I studied minutely. In seeing these things I travelled about two thousand miles ; but my stay was short, being limited to four months.

I mention these facts so that the reader may judge of my opportunities of study, and now I must leave my book in his hands.

I am much indebted to the painstaking care of Mr. Hundley, who has drawn the illustrations on wood for me, and to Mr. G. Pearson, the well-known wood engraver, who has cut the blocks. Both these gentlemen have exerted themselves in the kindest manner to render the illustrations such as I wished.

I have also to acknowledge the services of my daughters, who acted as my amanuenses, and thus rendered it possible for the book to be written during a long and painful illness from which I suffered while most of the letter-press was prepared. Their willing assistance was of great value to me.

TOWER CRESSY,  
NOTTING HILL, LONDON, W.,  
*October 1881.*





# CONTENTS.

## *PART I.*

### CHAPTER I.

Yokohama—The Grand Hotel—Sights in the Streets—Jinrikishas—Japanese hospitality—Sachi—Yedo, or Tokio—Letter-writing—The Castle—Winter in Japan—Temple of Shiba—Tombs of the Shōguns . . . . . Pages 1-18

### CHAPTER II.

Yokohama—A fire in the hotel—A Japanese banquet—Japanese dancing-girls—Music—Eating a live fish—Hara-kiri—The Mikado—The New Year—Tokio firemen—Japanese matting—The Hamagoten palace . . . . . 19-62

### CHAPTER III.

Preparation for long journey—By water to Kobe—Entrance of the Mikado into Kobe—Awadji, Sanda, Arima, Nara—The Mikado's antiquities . . . . . 63-103

### CHAPTER IV.

The sacred dance—A feast night—Kioto—The royal collections—Osaka . . . . . 104-123

## CHAPTER V.

The Japanese Calendar—Wakayama—Japanese cold and Japanese vegetation—Koyazan—Splendour of shrines and of scenery—Sakai—News of revolt in Satsuma—Return to Osaka—Feast of the god of riches . . . . . Pages 124-140

## CHAPTER VI.

Temple of Kioto—Japanese estimate of Christianity—Picnics—Honest workmanship—Lacquer-work—Value of Corean ware—Tea-drinking ceremony—Otsu—Futami-gaura—Kamiji-yama . . . . . 141-170

## CHAPTER VII.

Tidings of rebellion—Isé—Yokkaichi—Manufactures of Nagoya—Comparative estimates of wealth and skill—Castle of Nagoya—Sidsuoka—Fujiyama—Return to Yokohama 171-196

## CHAPTER VIII.

A Shinto festival—Nikkô—The great Sanctuary—Arrival at Tokio—Japanese reports and police supervision . . . . . 197-213

## CHAPTER IX.

A Japanese blue-book—Object of my visit—Exportation of ginger—Manufacture of carpets, etc. . . . . 214-224

PART II.

CHAPTER I.

RELIGION AND ARCHITECTURE . . . . .	Pages 225-320
-------------------------------------	---------------

CHAPTER II.

ANALOGIES AND SYMBOLS . . . . .	321-344
---------------------------------	---------

CHAPTER III.

THE LACQUER MANUFACTURES . . . . .	345-367
------------------------------------	---------

CHAPTER IV.

THE POTTERY MANUFACTURES . . . . .	368-414
------------------------------------	---------

CHAPTER V.

THE METAL MANUFACTURES . . . . .	415-430
----------------------------------	---------

CHAPTER VI.

ON THE MEANS BY WHICH FABRICS RECEIVE PATTERN . . . . .	431-449
---	---------

CHAPTER VII.

MINOR MANUFACTURES OF JAPAN . . . . .	450-466
---------------------------------------	---------



J A P A N :  
ITS ARCHITECTURE, ART, AND ART  
MANUFACTURES.

*PART I.*

CHAPTER I.

Yokohama—The Grand Hotel—Sights in the Streets—Jinrikishas—Japanese hospitality  
—Sachi—Yedo, or Tokio—Letter-writing—The Castle—Winter in Japan —Temple  
of Shiba—Tombs of the Shôguns.

IT was on the 26th day of December at 6.30 in the morning that I first saw Japan. As yet this strange country was enveloped in a soft mist above which the sun was only just rising, but as the mist dispersed we could see that the land was pleasantly undulating and richly wooded ; that in some of the valleys, fissures, and gorges nestled little picturesque villages ; that in sheltered spots palm-trees, with their plumous tops, rose high above the houses that found shelter beneath them, and that junks of quaint aspect ploughed the shallow waters of the coast.

A cry arises from the Japanese passengers, who are earnestly looking to the left (for we have several on board)—Fujiyama ! I look in the direction in which they gaze, but see no mountain. The undulating land in front is perfectly distinct, and is thrown out on a background of gray-and-white cloud which rises high behind it ; but I see no mountain. Under the guidance, however, of Japanese friends, I look above these clouds, and there, at a vast height, shines the immaculate summit of Japan's peerless

cone. I have seen almost every alpine peak in the land of Tell; I have viewed Monte Rosa from Zermat, Aosta, and Como; I have gloried in the wild beauty of the Jungfrau and the precipitous heights of the Matterhorn; but never before did I see a mountain so pure in its form, so imposing in its grandeur, so impressive in its beauty, as that at which we now gaze. I do not wonder at the Japanese endowing it with marvellous powers; I do not wonder at this vast cone around which clouds love to sleep being regarded as the home of the dragon—the demon of the storm,—for surely this mountain is one of nature's grandest works!

Rounding a promontory we soon enter the bay of Yokohama, fire two cannon, and drop our anchor.

In a few minutes certain officials come on board, and the ship is surrounded by a score of native boats. Some belong to hotels, some seek to take passengers or merchandise on shore, some bring out servants of the company to which our ship belongs, and others a variety of things which it is impossible to describe. A scene of life and activity thus springs up around us of a character so novel as to be both interesting and amusing. A small steam-launch is now moored to the side of our great vessel, and General Saigo, the commander-in-chief of the Japanese army, who is on board, invites me to step into the launch and accompany him on shore: the launch is a Government boat which has been sent to convey the General to land.<sup>1</sup> Accepting the kind invitation I am soon seated in the boat, where we find the son of the General, who is a cheerful smiling-faced urchin about two years old. No sooner does the father see the little fellow than he caresses him with that warm affection which the Japanese at all times show towards their children; but there is no kissing, for kissing is unknown in the East, and while the General manifests his love for his child I yet feel that the little fellow has not received all his due, and I almost long to kiss him myself. The screw of our little launch is soon in motion, and in a few minutes I stand on

<sup>1</sup> General Saigo was returning from America, where he had acted as the commissioner for Japan at the Philadelphia exhibition. I met General Saigo and his party at San Francisco by arrangement, so that we might travel together to his country.

a land which, as a decorative artist, I have for years had an intense desire to see, whose works I have already learned to admire, and amidst a people who are saturated with the refinements which spring only from an old civilisation. With the view of reaching my hotel I now get into a jinrikisha, a vehicle somewhat resembling a small hansom cab, only with a hood that shuts back. It is lightly built, has two somewhat large wheels, and slender shafts united together by a tie-piece near their extremities. It is drawn by a man who gets between the shafts and most ably acts the part of the best of ponies, or sometimes by two, or even three men. In the latter cases the tandem principle is adopted, and the leaders are attached to the vehicle by thin ropes. As soon as I am seated in my carriage, which is scarcely large enough to contain my somewhat cumbrous body, my tandem coolies (for I have two) set off with a speed which is certainly astonishing, if not alarming, and I soon find myself at the entrance to the Grand Hotel—a European house—where I secure my room (terms three and a half dollars or fourteen shillings a day, including everything save fire and wine).

Breakfast this morning was somewhat neglected, for the excitement of nearing land after a twenty-one days' sea-voyage had lessened our appetites. It seemed impossible to spare time for a hearty meal when, with the movement of our vessel through the water, shifting scenes both strange and beautiful were constantly presenting themselves to our sight. The keen, fresh, exhilarating air, the cloudless sky, the bright and cheering sunshine, and the gallop through the wind in my tiny carriage had caused nature to assert itself and demand some refreshment for the inner man.

Sitting down to table at the hotel I partook of a somewhat hurried meal. Fish, entrées, and joint were presented in due sequence, as though I were sitting in the Grand Hotel at Paris; while grouped on dishes were tins of Crosse and Blackwell's potted meats, and Keiller's Dundee marmalade and jam. I confess that while these luxuries were in the most perfect state of preservation, and in every sense enjoyable, I was disappointed in



seeing such familiar forms of food instead of the tentacle of an octopus, the succulent shoot of a bamboo, the fin of a shark, or some other such natives dainties as I looked for.

Having finished my meal, I am joined by a gentleman who is to act as my secretary while I am in the country, by Prince Henri of Liechtenstein, and by Prince Alfred Montenuovo (two Austrian princes with whom I have been a fellow-passenger from San Francisco), and we start for a walk, the secretary being our guide. We pass through the European settlement of Yokohama, where beautiful villas—in character half English and half Japanese—nestle in lovely gardens, and on to the native town. Here all is strange and quaint beyond description. The shops are without fronts and their floors are raised above the ground by one high step; they are matted, and the goods are displayed on stands which resemble the so-called “stage” of a greenhouse. Strange articles of food, strange people, strange objects meet the eye on every side. We stop, we look, we admire, we wonder. We are looked at: smiles of amusement at the interest which is taken in things, to them common, meet us at every turn. We watch children play,—a little girl bounces a ball and turns round while the ball is ascending from the ground for her to hit again. We pass by a canal which is tunnelled through a hill, and on which the strangest of boats float; we enter the precincts of a Buddhist Temple, but we must take our boots off before we cross the threshold. We return home by crossing “the bluffs,” from which we have a glorious view of the town and the bay, and by a road which, bordered by curious fences (Figs. 1 to 15), winds its way through nurseries where strange trees abound. I need scarcely say that we have enjoyed our walk more than words can tell. Indeed it would be almost impossible to describe the impression of novelty left on our minds; but to give the reader some notion of the strange aspect of things I may repeat a remark made by one of the Austrian princes during the stroll. “Had we died,” he said, “and risen from the dead the scene presented could not be more strange.”

The princes dine with me, and at 8.30 we set out again ; this time in jinrikishas, each drawn by one man, who now bears a lantern, as it is dark, and off we go at almost the pace of a race-horse. We laugh heartily at the shouts of the men, the bobbing of the lanterns, the shaking of the vehicles, and the excitement of the furious run. In about fifteen minutes we alight in front of a large house, into one room of which we enter. Here our conductor orders for us a native repast, to which are to be added the pleasures of music and the dance. The room is a plain square, but there is European glass in the windows, and the doors have European fasteners. Mats cover the floor, and on the mats stand two brazen vessels (called hibachi), each containing a few bits of ignited charcoal ; and these primitive and insignificant fires afford the only means by which a Japanese room is warmed. We are favoured with Chinese chairs and two small tables, while the natives, who shortly come to serve the repast, or to amuse us by their music and dancing, kneel in front of us on the floor. Preparations having now been completed, a large lacquer tray is brought in, and placed in the centre of the group of kneeling female attendants. On this tray rests a dish of sliced raw, unsalted fish, with condiments of various kinds, all being arranged much like the French dish of *Tête de veau vinaigrette* if tastefully garnished with leaves. European plates are used out of compliment to us strangers, but chop-sticks are supplied instead of knives and forks. We taste the dish after many unsuccessful attempts at getting the food to our mouths by the aid of the chop-sticks, but strange to say, the viands have the flavours, and the condiments are almost tasteless. After the raw fish comes fried fish, and with it hot sachi.

Sachi, although generally regarded in England as a spirit, is in reality a white beer made from rice. Like all alcoholic drinks, sachi varies much in quality ; and the Japanese estimate its excellence by flavour, aroma, and other qualities, as we do our port and other wines. It is drunk both cold and warm, but it is not made hot by admixture with water, but is itself warmed ; and in this condition it is now offered to us.



FIG. 1.

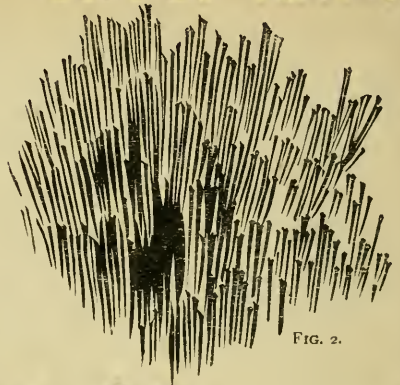

FIG. 2.

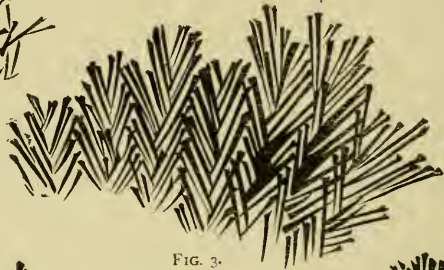

FIG. 3.



FIG. 4.

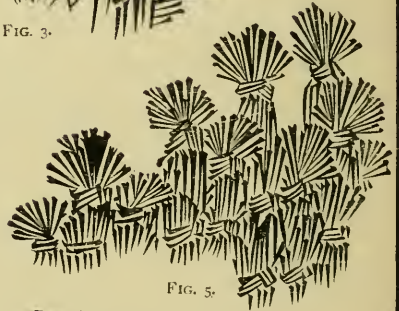

FIG. 5.



FIG. 6.



FIG. 7.

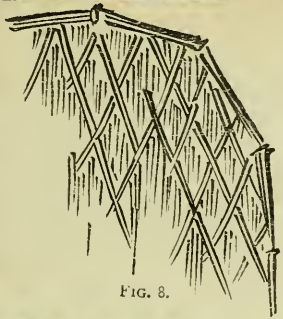

FIG. 8.

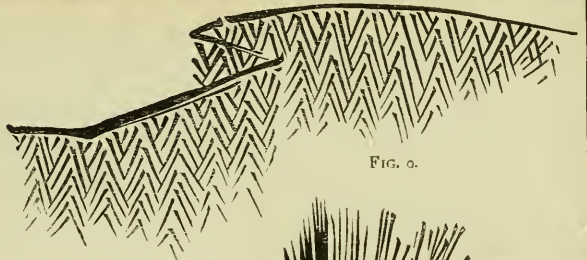

FIG. 9.

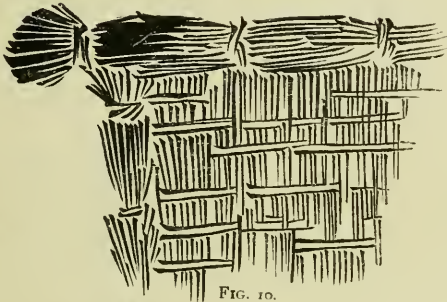

FIG. 10.

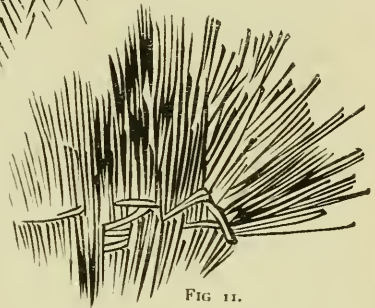

FIG. 11.

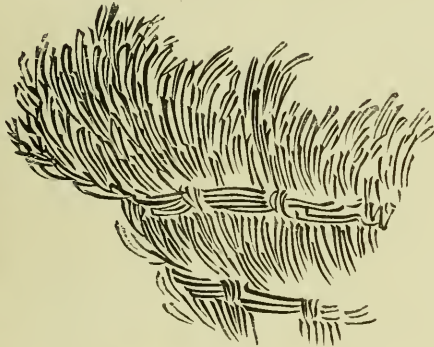

FIG. 12.

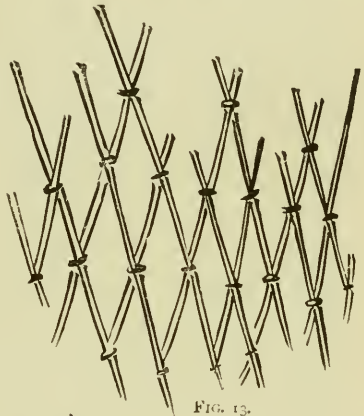

FIG. 13.

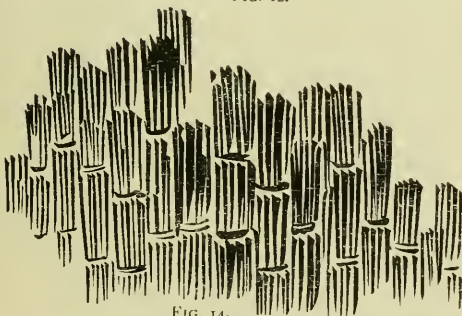

FIG. 14.

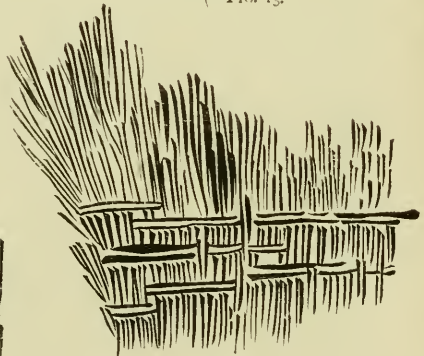

FIG. 15.

Sachi cups are usually small earthen vessels of about two inches in diameter, much resembling in character shallow tea-cups, or deep saucers. They are without handle, and are offered to the guest empty after being placed in hot water for a few moments if he is to drink the sachi warm. Into these empty cups a second serving-maid pours the warm sachi from a delicately-formed china bottle.

Following the fish and the wine a dish of sea-slugs with herbs and sea-weed is served, but the mollusc is as tough as leather, and my powers of mastication are altogether overcome. After the repast, music begins with the samasin (banjo), and the coto (horizontal harp), together with certain drums (the tsudzumu and the taiko), while girls dance to the weird sounds—their motions being graceful but strange. This over, there is singing of native songs, after which we all leave, take our places in the jinrikishas, and are drawn home at almost lightning speed.

On the following morning I begin to make observations with some care. Yesterday everything was so new that impressions resulted chiefly from general effects, or curious incidents, while details were passed almost unnoticed. I now, however, seem to be more able to mark accurately what comes before me. Standing on the steps of our hotel, I glance upwards with the view of noticing the nature of the building in which I have for the present taken up my abode. To my astonishment what I yesterday regarded as a solid stone edifice turns out to be a mere wooden framework bearing on its surface thin slabs of stone, each of which is drilled partially through and is hung on two common nails.

This hotel is beautifully situated, having its chief face overlooking the sea, from which it is separated by a broad and well-made road. On its right is a canal which here meets the ocean. As I stand on these steps I have above me a cloudless sky of the deepest blue, an ocean rippled by the smallest of waves, and reflecting the azure of the heavens above. The white sails of picturesque boats reflect the rays of the sun, hidden from my view by the house in front of which I stand; while the air has a crispness, due to the slight frost of the night, which makes it in

the highest degree exhilarating. I breakfast off fish, ham, eggs, and tea, as though I were sitting at my own table in London, instead of being 12,000 miles from home, and then set out to view the shops and their contents. During my walk I find many curios that are to me quite irresistible, and I buy, I fear, in a truly reckless fashion. At 5.15 I return home somewhat tired, having had a perfect "field day" amidst the shops.

While I was dressing, Prince Henri came into my room and asked me to join him and Prince Montenuovo at dinner. Thus passed my second day in Japan.

I find the following scraps noted in my diary under date December 27th. It is customary here to go to a shop to select a number of goods, and then to ask the owner to send all the objects selected to your house, or hotel, for you to look over and decide upon at your leisure.

The people here are most polite and charming; at one place while we were making purchases tea was served to us. The tea is by no means strong, is pale yellow (almost amber) in colour, and is drunk without milk or sugar. It is served in small cups without handles or saucers.

The native town of Yokohama is lit with gas, while the European quarter has at night dark streets. The foreign settler objects to a gas rate.

The next morning I go by appointment to Yedo (Tokio, or the northern capital) by 9.34 train. The railway connecting Yokohama (the port of Tokio) with Tokio is eighteen miles in length, is well built, and is one of two railways now existing in Japan; the other railway connects Hiogo (Kobe) with Kioto (the southern capital). The Yokohama railway is of specially narrow gauge, and the carriages are more like omnibuses than any to be found on our lines—being small in size and entered at the end. A train leaves Yokohama for Tokio, and Tokio for Yokohama, every hour of every day in the year, and every train carries mails; hence, while Yedo and Yokohama are eighteen miles apart, there is a delivery of letters in both places every hour of every day.

These places, and indeed all the towns of Japan, are now connected by telegraph wires, by the agency of which messages can be sent in the native character or in most of the European languages ; but for conveying a message in a strange tongue an extra fee is very reasonably demanded.

The line from Yokohama to Yedo skirts the bay throughout the greater portion of its length ; and the scenery along the route, though curious, presents few features of marked interest. The dresses, however, of the female peasantry who happen to be in holiday attire are quaint and pleasing, while the flowing robes of the men contrast favourably with our set and inartistic dress.

At Tokio, I am met by General Saigo and Mr. Sekisawa,—the latter being a gentleman who was one of our party from San Francisco to Japan. General Saigo has with him his carriage, which is of European make, and is drawn by a horse ; but a “runner” precedes the carriage on foot, as was common in England in more early days. This practice of employing a running groom to precede the carriage is rendered necessary by the fact that horse carriages have but recently been introduced into Japan. For centuries the inhabitants of towns have been in the habit of walking in the middle of the streets, for no Japanese town that I remember has properly made footpaths at the sides of the roads ; and wells imperfectly protected are often situated in front of the shops.

General Saigo is a man of handsome appearance, and stately bearing, of about thirty-seven years of age ; like many southerners,<sup>1</sup> he is by no means small of stature. His house, which we soon reach, is a wooden building in the English style. The floor of the room in which I am received is covered with a “tapestry” carpet, and in it stands an American stove, which can scarcely be regarded as beautiful, though it is probably useful. The furniture is of European character, but surely of American make, and in pattern resembles English furniture prior to 1862.

As we sat on European chairs, tea was served in native style. It had been arranged that I should visit Mr. Sano—one of the ministers ; but Japanese etiquette demands that a note be sent

<sup>1</sup> General Saigo is a native of the province of Satsuma.

immediately before the visit, to ask if all things are ready for the reception ; General Saigo therefore writes the first Japanese letter which I have seen written.

His writing-box is about 11 inches in width, 12 inches long, and 2 inches deep, and contains a roll of fibrous paper somewhat bibulous in character, a stick of Indian ink, a slab on which to mix the ink, a small water vessel, and a few brushes formed of vegetable hairs. From the box he takes the roll of paper, an inch or two of which he unrolls and arranges as flatly as possible. He next mixes a small quantity of ink, and then holding the roll of paper in his left hand, begins to write with a brush, previously dipped in the Indian ink, upon the spread out portion of the paper. The first character is made at the upper right-hand corner, the second follows immediately under it, and so on, till a vertical column is formed, then a second column is written, and so on ; in each case the new line of writing being commenced at the top and finished at the bottom of the sheet, and being to the left of the previously written columns. When the letter is completed, the portion of the paper occupied by the writing is torn from the roll, and folded, and the letter is placed in a lacquer box, round which the writer ties a silk cord.<sup>1</sup> A servant carries the box to the house of the receiver, who himself takes from the box the letter which has not been touched by the messenger. An answer comes in like form saying that all is ready, so we drive to Mr. Sano's house, which is a fine old Japanese building near the outskirts of the city. Two rooms at least of this thoroughly Japanese residence are furnished in European fashion, and of the residences belonging to Japanese ministers, or high officials, which I happened to see, this, as a specimen of European furnishing, was one of the most successful.

Mr. Sano was the commissioner representing the Japanese Government at the Vienna International Exhibition in the year 1873, and during his visit to Europe at this period he seems to have studied most carefully the art industries of the west, and the nature of our manufactures ; for the suggestions which he

<sup>1</sup> These boxes are sold in England as "glove-boxes."



made to his own people upon his return appear to have proved very valuable to the industries of Japan.

During Mr. Sano's residence at Vienna he was requested by his government to make purchases of such manufactured objects as he thought likely to have an interest for the Japanese, with the view of their being placed in a museum which was about to be established in Tokio, much after the plan of our South Kensington Museum. Unfortunately the goods selected were lost in Yedo Bay by the foundering there of the vessel which was chartered to convey them to Japan. In spite of this dire calamity, an excellent museum has been established in Tokio, of which Mr. Sano was the head and chief, although he has now relinquished the post in favour of Mr. Machida, a gentleman who has travelled in Europe, and who both speaks and writes English well.

Mr. Sano is a man of aristocratic bearing, and decidedly of large stature for a Japanese. He interests himself especially in the advancement of the art industries of his country which have in a large degree been saved from the corrupting influences of European taste through his exertions.

After I had determined to leave England for Japan, my old friend Mr. Philip Cunliffe Owen (now Sir Philip) suggested to me that I should do what I could to repair the loss sustained by the Japanese through the wreck of the vessel containing the specimens of European manufactures. I therefore appealed to my manufacturing friends; and the result was that I took with me to Tokio a collection of objects such as could only prove valuable to the Imperial Museum. Sir Philip Owen gave me introductions to his Excellency Mr. Sano, General Saigo, and other Japanese ministers, and it is to him that I am indebted for the many valuable friends whom I still retain among the leading men of Japan.

The presentation of this gift from our manufacturers to the representatives of the Japanese Government was the object of my visit to Mr. Sano.

Mr. Sano received me most kindly. During our conversation (which we carried on through the kind and careful interpretation of Mr. Sckisawa) tea was served in native fashion. After a sump-

tuous luncheon, served in European style and with European wines, General Saigo takes me to the Castle, where Mr. Sano and Mr. Asami (another of our American party, who is engaged under Mr. Sano in translating European works pertaining to manufactures into the Japanese language) met us.

The Castle, which dates from the year A.D. 1355, was formerly an immense building enclosing gardens. It now stands in the centre of the more modern town of Tokio, which was founded in the year A.D. 1600, and was ultimately built around it. Although recent civil wars have destroyed much of this ancient castle, some huge towers and immense battlements, formed of stones of extraordinary size remain. The Castle enclosure is surrounded by a broad moat, on the inner side of which rise the vast walls of the fortress: and if we may judge from its appearance, no castle in Europe is more impregnable. The water of the moat is broad, and the roadway skirting it on the outer side considerably above its level. Inside the walls there is a charming garden, used now as a pleasure ground during the summer months by the high officials of the Government. In this garden there are small artificial lakes and streams of water, which are crossed by picturesque bridges, and are in part sheltered by greatly contorted trees; and here also are one or two charming little tea-houses. Although the Castle grounds are not usually open at this period of the year, General Saigo has not only had the gates unlocked for us, but has also had the tea-houses opened, and tea prepared for our refreshment.

It is the 28th day of December; yet as we saunter through these beautiful grounds I see trees laden with camellia blossoms looking as fresh as if it were summer. General Saigo gathers a bunch of these beautiful flowers and presents them to me, after which my companions return to their homes and I go to the British Embassy, where Mr. Mounsey (the First Secretary of the Legation) presents me to Sir Harry Parkes, and insists on my staying to dine with him. I return to Yokohama by the ten o'clock train.

The morning is clear, bright, and slightly frosty, while the

air is singularly pure and bracing. With Prince Liechtenstein and Prince Montenuovo I start for Tokio, where we meet Mr. and Mrs. Mounsey, at whose invitation we were to-day to visit the capital. Two carriages convey us to the great Buddhist Temple of Shiba, which is situated in a richly-wooded suburb of the city. As the Castle stands in the centre of the town, and the moat surrounding it is bordered on its outer side in part by fields, trees, and various kinds of vegetation, while beyond this rural district the city spreads itself as a huge ring, a journey from one side of Tokio to the other is curious, for upon leaving a densely-populated district we often come upon fields or gardens as we approach the centre of the town.

Shiba lies in the north-east quarter of Tokio. It is reached by a pleasant short drive from the railway station. The impression which I now receive upon first beholding the magnificent temples and shrines standing before me as we step from our carriage is most delightful. Buildings so rich in colour, so beautiful in detail, so striking in symbolism, I have never before seen, or even dreamt of. Had a Gibbons been employed on the wood-carvings, had the colourist of the Alhambra done his utmost to add to forms, which in themselves are almost perfect, a new charm through the addition of pigments, and were the whole of such details subordinated to fitting places in a vast architectural edifice by the architects of the Parthenon, no more worthy effect could be produced than that of the buildings on which my eyes now rest.

The Temple of Shiba, like most of the large temples dedicated to the service of Buddhism, consisted of seven buildings, one of which may be regarded as more strictly in itself *the Temple*, while another is in all cases a pagoda,—the pagoda bearing much the same relation to the Buddhist edifice that a spire does to a Christian church. Unfortunately the chief building of the seven has been lately burnt by, it is believed, revolutionary incendiaries, and I am informed that this building was more beautiful than any now remaining; yet how any building could be more beautiful than those which have escaped, I am at a loss to

understand. (Fig. 16 gives the water-tank in the courtyard of this temple.)

We walk through the courtyard inspecting the long rows of stone lanterns, and viewing the exteriors of the various buildings

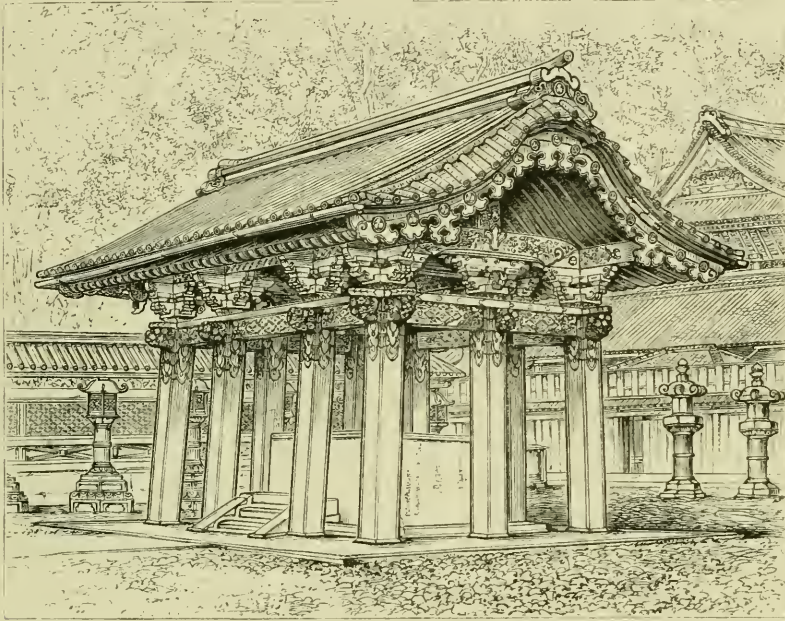

FIG. 16.—THE WATER-TANK AT SHIBA,

With its monolith columns, on the tops of which festooned drapery in colours and gold is painted.

on which we find birds, flowers, water, and clouds carved with a tenderness and boldness scarcely to be surpassed, and so coloured that each object retains its individual beauty, while the various parts combine to produce an effect almost perfect. The art treatment of the natural objects is semi-conventional, the carving is of the crispest, and the subjects are chosen with the view of symbolising the power of the Buddhist's god over all created things.

Shiba is not only a Buddhist shrine, but, like our Westminster Abbey, is a resting-place for the mighty dead. Here five of Japan's great Shōguns (also called Tycoons) were buried, and the Shōgun (who was practically the temporal ruler of Japan)

was of the Buddhist faith, while the Mikado (whom we have described as the spiritual ruler) was of the Shinto religion. Shôguns found their resting-place in tombs of great beauty, while over the ashes of the Mikados are heaped mere mounds of earth.

We are looking and wondering at all the loveliness outspread before us when a shaven-headed priest comes forward to conduct us into the largest of the edifices which now remain. Before entering it we have to put off our shoes. This it was right that we should do, were it only because the balcony to which the steps before us lead, and the floor of the temple itself, are of polished black lacquer. The surface of these floors may be compared with that of the best papier-maché tray that Wolverhampton ever made.

There is little in the way of wall in connexion with either Japanese temples or houses ; but of the structure of their buildings more will be said when we come to consider their architecture. However, the building before us is a large enclosed space, covered by a massive roof, supported on uprights, between which are what we may regard as movable shutters ;—the columns and shutters forming the boundary of the building. The floor of the temple extends about six feet beyond the central enclosed part as a balcony, and it is this balcony which I have just mentioned as being bright black. The roof of the temple overhangs the balcony and protects it from the weather, while the constructive rafters and joists which support it are left fully exposed to view. Internally we have a ceiling of which the structural features are not visible. The ceiling is panelled out into small squares, and is decorated ; red, blue, green, white, and gold being applied to it in all their intensity.

It might be thought that such a system of colouring as this could only produce a coarse and vulgar effect ; but this is not so, for the overhanging roof which approaches within about four feet of the railing of the surrounding balcony does not permit the entrance of any excessive amount of light ; and the light which ultimately reaches the ceiling is all reflected, and that from a black floor.

We are now taken by our shaven-headed priest to see the tombs of the Shôguns. In front of each tomb stands a square building or shrine, one of which by his orders is opened at both back and front, that we may look on the monument behind.

I am so much pleased with the one temple which I have been permitted to enter, and my art enthusiasm has been already so fully kindled, that my desire to see the interior of these sacred shrines becomes almost irresistible; but I am told that none but great officials can enter these sanctuaries, as each building contains the SACRED name of the now deified Shôgun whose remains are entombed behind. I believe that the holy father mistakes my enthusiastic admiration of the art of the edifice for religious enthusiasm, as he somewhat excitedly exclaims, "You are great Shôgun," and allows me to enter a building which few, if any, Europeans have up to this time been permitted to inspect.

These shrines are as beautiful as the larger temples which we have already seen, and their details are as perfectly wrought. But as yet I fail to comprehend the object of these buildings, for what the *sacred name* of a deceased Shôgun may be, I do not understand. Ultimate inquiry led me to see that throughout Japan there is a strange confusion of Buddhism and Shintoism; for while Shintoism deifies heroes, Buddhism, in its purity, does nothing of the kind. Nevertheless, as the Mikado, while yet regarded as the God incarnate of the Shinto Church, offers in public on certain days of the year prayers for his people at certain Buddhist shrines, it is not to be wondered at that the leading sanctuaries of Japan should betray a blending so inconsistent.

Upon the death of a famous Japanese, be he daimiô (baron), hero, benefactor, or Shôgun, he is exalted to the rank of a god, when his name in the god world is allotted to him. This name, sacred and unpronounceable by mortal lips, is inscribed on a tablet of about two feet in length by four inches in breadth, bordered by a richly carved margin; and it is this god name which the shrines in front of the Shôguns' tombs are intended to encase and preserve. Every precaution is taken to insure the safety of

these tablets, as in the belief of the Japanese the gravest calamities might befall the nation if any should be lost or destroyed.

On this memorable day, which will always be a "red letter day" in my history, I learnt many facts of deep interest, and I have certainly beheld, enshrined in cryptomerias and other cone-bearing trees of vast proportions, an amount of architectural beauty such as I have never before seen ; and I may here mention as evidence of the liberality of the Buddhists, that when Lady Parkes applied to the high priest of Shiba for permission to have the Church of England service performed in one of the chapels connected with this great shrine, her request was at once granted. Hence Christian worship is offered every Sunday in this greatest of Buddhist temples.

## CHAPTER II.

Yokohama—A fire in the hotel—A Japanese banquet—Japanese dancing-girls—Music—Eating a live fish—Hara-kiri—The Mikado—The New Year—Tokio firemen—Japanese matting—The Hamagoten palace.

THIS 30th of December was spent chiefly in receiving official visits, in arranging for an interview with Mr. Machida, the present director of the Tokio Museum, in calling upon important personages in Tokio, and in dining with Sir Harry Parkes, our minister. I returned to my hotel at Yokohama ; but the night was not to pass without its excitement. I was awakened from my sleep by the cry of "fire." Upon putting my head outside the door of my chamber, I saw the manager of the hotel hurrying off in his nightshirt in search of a fire-engine. Dressing in all haste, I found that our hotel was on fire and that the fire was in the floor above me. A large hole in the skirting-board and wall showed that the interior of the partition (which is not truly a wall but a lath and plaster "studding") was all ablaze. Seeing the danger of our position, I shouted for water, and before the Japanese servants could bring the buckets, I rushed into the nearest bedroom and seized the poker, to the consternation of a lady who had just stepped out of bed. With this poker I hacked down the wall as high as I could reach, and found all the joists in flames. Water was now plentifully thrown on the burning timbers, and a ladder enabled me to climb to the ceiling of the passage in which the fire was rapidly spreading, but after some hard work we succeeded in overcoming our enemy. In this incident I was struck by the fact, that while no engine came till



the fire was out not one visitor in the hotel, whether English, American, German, or French, offered any help, while a great gaping lubber, whom I afterwards found to be the proprietor of the hotel, stood calmly looking on. During the following day I was thanked by several of the inmates of the hotel for the service I had rendered, and even the lady whose composure I had so much disturbed complimented me on my energy; yet I was informed that our landlord considered it no part of my duty to put out fires on his premises, and that he was well insured.

The fire being out, I sallied forth to inspect the native fish market, for it was now seven o'clock in the morning. Here I saw piles of octopuses; some heaps being of reddish hue, while others were of leaden aspect, but the tentacles of these strange creatures gave the heaps a look of motion and life, which, to say the least, was strange. Here are also bivalve molluscs, ten inches in length, which I can only regard as over-grown mussels, large creatures of the shark character, some ten feet in length, and in a tub live fish, including the royal *tai*; while on tables and stalls are ranged some of the oddest monsters which I ever saw offered for food in any land.

At the entrance to the market, through which I return, sits a money-changer, from whom I get some picturesque coins, now obsolete, the former coinage having been entirely superseded by a silver and paper currency after the modern American fashion.

At 9 A.M. I left for Tokio, having been invited to partake of a native banquet to be given by certain foreign secretaries of legation to the Austrian princes. Each of our hosts, I understood, was to invite one friend, and I was the honoured guest of the Hon. James Saumarez. The luncheon was served in the most fashionable of Japanese tea-houses, being that in which the ministers have state dinners, and in every respect according to the highest rules of Japanese taste and etiquette.

At the Yashiki (spread out houses) of those accomplished linguists, the brothers Siebold, to whom the Japanese tongue is as familiar as any European language, I met Prince Henri of

Liechtenstein and Prince Montenuovo, Baron Rosen, Baron Goldschmidt, and Dr. Roritz, to the latter of whom I owe a vast debt of gratitude for kindness which I afterwards received when far removed from European civilisation. Our party being formed, we accompanied our hosts to the tea-house, where, taking off our shoes, we ascended the stairs (for this house is two stories in height, a thing unusual in Japan), and entered the banquet-room.

As this banquet was characteristic of the nation, I will attempt to describe it. The room, or rather rooms, in which we feasted, so far resembled the front and back parlours of a London villa that they were formed into one for our use by the removal of certain "slides," which may be said to represent the "double doors" of small English houses. As we entered the room, we saw, attached to the right-hand wall, a slightly-raised dais, more or less shut off from the main portion of the room with a sort of enclosed altar, on which rice-ears rested as an offering to the gods. This enclosure is arranged with scrupulous care; an unbarked stem of cherry wood stands as an upright at its outermost corner, the dimensions of each plank, upright, or other piece being determined by rule. This is the "sacred niche" (or enclosure) which the Mikado, as the god incarnate of the Shinto Church, would occupy were he ever to visit this hotel, and through an opening at the end of the partially-enclosed dais his food would be served by those who could not, through the smallness and position of the opening, see his face.

The greater portion of the wall facing us as we enter is occupied by a window of about three feet in height, resting on the floor of the room, but it is high enough to serve the purpose for which it is intended, as all Japanese kneel upon the floor when collected together for any entertainment; indeed, there is neither chair, table, nor anything that we can regard as furniture in any native Japanese room. The left-hand side of the apartment is entirely occupied by a continuous series of windows, outside of which there is a balcony; and these windows are so high that we can readily walk on to the balcony when they are open. The

other sides of the room consist of plastered walls, the plaster being of agreeable texture and colour.

But although these rooms bear a certain resemblance to European rooms, there is nothing European about them ; indeed, they are not only of purely Japanese character, but are constructed according to the most rigid laws of Japanese etiquette. The windows consist of light frames filled in with a delicate and beautiful wood lattice-work covered with thin paper ; hence it is impossible to look out without moving one of the window sashes ; but as all window-sashes in Japan are so arranged that one can slide past another horizontally, this is not a difficult matter. The floor is covered with matting ; the ceiling, like the window-sashes, is entirely of unpainted wood, and altogether the room has an air of cleanness and beauty which is most pleasing.

When we entered the room the window-sashes were almost all removed, but the sun shone brightly although the air was cold. A cushion about one inch in thickness and fourteen inches square was placed for each of us to kneel upon, but the real object of these cushions is that of indicating positions, the place of honour being that next to the Mikado's dais, and from this position the seats gradually decrease in value. These cushions were covered with a cotton material of indigo-blue tint which contrasted very pleasantly with the soft yellow of the mats, the gray-buff of the wood, and the green-gray of the walls. Four Hibachi (or fire-holders) were placed on the floor, each of which was in this case a square vessel formed of dark wood lined with metal. Each Hibachi was half full of a heavy wood-ash, of course incombustible, and on the centre of this ash rested two or three small pieces of ignited charcoal. The Hibachi gives out but little heat, and certainly fails to alter the temperature of a Japanese room to any perceptible degree. In an English room such a contrivance would be highly dangerous, as the carbonic acid gas resulting from the union of the burning charcoal with the oxygen of the air would render the atmosphere almost poisonous ; but a Japanese room is so perfectly ventilated, owing to the slight manner in which its sides are constructed,

that no such danger is to be apprehended. Indeed, the Japanese may be said almost to live an out-of-door life, the house being rather a floor raised above the ground with a substantial roof than a series of rooms properly enclosed by substantial side walls.

When we were seated, or rather arranged, on our cushions in a kneeling posture, a female attendant placed beside each of us a smoking-box containing a small bamboo cup, in the bottom of which was a little water, and a pipe (the bamboo cup is intended to receive the ash emptied from the pipe). A tobacco-box of the finest lacquer, with both the lid and the body bordered by a metal rim, was passed round, and the pipes were charged. A Japanese tobacco-pipe is exceedingly small, the bowl not holding sufficient tobacco for more than two whiffs, yet it is generally most exquisitely made with a metal bowl and mouthpiece and a bamboo stem—the metal being not unfrequently Damascened in the richest manner. The tobacco is cut into the very finest shreds—much finer than anything we know of here: the tobacco-pipes are charged and after the second whiff the ash is emptied out and the operation of filling repeated. This process is continued at discretion. With pipes at work tea was first served, the cups being of blue-and-white porcelain of about two and a half inches in diameter; the tea was in a small Banko tea-kettle with bamboo handle. The cup, being filled with tea, was placed by the serving-maid on a small maroon lacquer stand resembling a saucer elevated on a foot. On this stand the cup is offered to the guest, but the guest simply takes the cup: the stand remaining in the hand of the serving-maid. No sugar or milk is used, the beverage being drunk in its pure condition.

Two girls in gorgeous apparel enter, and passing to the centre of the room, fall on their knees and prostrate themselves till their heads nearly touch the floor. They wear the most artistic of dresses, and their hair is braided in the quaint fashion which is general here: it is stiff and smooth, being formed into flat bows rendered firm by a lavish use of strange-smelling cosmetic. The hair is jet-black, and two hair-pins form the

ornaments of each *péruche*. Powder is freely used on the face, but no attempt is made to disguise the fact, for the powder ends with a regular and well-defined line which extends down the back part of the cheeks. The lips are of the brightest red, being painted with a most potent pigment, while the central portions are accented by lustrous touches of a green-gold bronze;—happily kissing is unknown in Japan! One of the girls wears a broad green sash of the richest and most mellow colour; this is a charming art work, and over it spreads a spray of the gourd, worked in lustrous plumbago-black. The drawing of this spray is perfectly marvellous, having all the vigour and beauty of the living plant, while it is yet a consistent ornament of the surface which it decorates.

Two more girls (dressed in the same way and kneeling behind the first two) make their obeisance, and now a third pair enter and prostrate themselves. These last, dressed more plainly, are servers of food, and give to each guest a square black lacquer salver about fourteen inches in diameter; another serving-girl enters bearing a large tray filled with saucers of food, which is placed on the floor of the room. The four more gaily-attired girls now leave the room, and soon re-enter with a *taiko* (or drum beaten with two sticks), two *tsudzumu* (or small drums beaten with the fingers), a *yokobuye* (or flute), a *samasin* (or banjo), and a *coto* (or horizontal harp).

The music now begins, all the instruments being played but the *coto*, the musicians kneeling on the floor, two at the right and two at the left of the door. At the same time viands are handed round, one saucer being placed on each of our trays. These saucers each contain a lump of soft, dough-like substance covered with a fine bright-green flour, a circular piece of semi-transparent plastic matter like a sectional portion of fancy sugar-stick having a red exterior and a white flower in its centre, and a piece of white gelatinous matter of oblong shape. Immediately after the distribution of these luxuries a serving-maid enters bearing another oblong tray filled with saucers of confections and other articles of food—an orange preserved in syrup, a small

fresh fish (like a sprat) opened and spread on a roll of rice saddle fashion, an oblong object about three inches in length, black in colour, and filled with white seed-like specks (exceedingly hard), and a semicircular slice of white gelatinous matter with a red crenated margin. I failed signally at first with the chop-sticks which were given to me ; but on seeing how they were used, I soon found that I could pick up single grains of rice as well as larger pieces of food ; but Japanese etiquette allows a bowl or saucer to be raised to the mouth for the convenience of the person eating.

I try to eat the putty-like compound with green exterior, but in attempting to bite a piece from the mass I encounter a serious difficulty, for instead of being wholly successful in my attempt I find that in removing my saucer from my mouth I am drawing out an attenuated string of the ductile dainty, and that the portion in my mouth is still connected with the larger mass now resting on the floor. The more I try to separate this connecting cord the more my difficulty increases, and I verily believe that one mass of such food could be drawn into a thread which would span the Pacific itself : at last, in my agony, I swallow the mass, but even then it seems an age before I can break the thread which binds me to the dish on the floor. Being satisfied with one mouthful of this dainty, I try the gelatinous rice-cake which with an effort I in part consume. The red morsel is passed over, being so pretty that I do not think it right to venture upon it, but I try the more inviting confections, amongst which the orange must take a first place.

The strangely weird, but somewhat exciting, music being over, the lady who had performed on the small hand-drums (one of which she held on the left knee and the other on the right shoulder) lays aside these instruments for the coto or horizontal harp, and four more musicians—girls who can sing as well as play—enter, each with a samasin or banjo. The music now began again accompanied with singing ; and the singing was even more strange and weird than the music.

Two basins of clean warm water were now brought, each on a slightly-raised lacquer stand, and placed on the floor in the centre

of the guests. With them came two bottles of warm sachi, one being dry and the other sweet, while the sachi-bottles were, like the bowls, of blue-and-white porcelain, and each rested in a little lacquer frame. Small porcelain sachi cups, such as we in England are now familiar with, were then brought in, and one of these was placed on the tray belonging to each of the more important visitors, who dips it in the warm water, and holds it up to be filled with sachi. It is expected that the guests who are thus first served shall swallow the contents of their cups quickly, rinse them in the basins of water, and throw them across the room to the friends with whom they wish to take wine. It is owing to this custom that sachi cups are frequently covered with basket-work, especially when they are made of egg-shell china, for this covering prevents their being readily broken.

Music is now being performed and the sachi cups are frequently passing across the room when soup is served—the soup being brought in little black lacquer bowls, each of which has a cover, and one of which is placed on each of our trays. The soup is clear, but with a sediment not unlike that common to game soups, but in it float a number of pale brown fungi, somewhat resembling the mushroom, but distinct in aspect and very different in flavour. The basin is raised to the mouth, and with the chop-sticks the fungi are got from the bowl: I observe that the Japanese sip their soup slowly and carefully as we should a wine of rare vintage. After each sip they return the bowl to the tray and replace the cover so as to keep it warm.

The music being over, the four girls who first brought instruments rise and prepare for the dance: they move into the smaller room, which I will for the moment call the back parlour, and we rearrange ourselves so that all may see them. The four samasin players begin a plaintive lay which they accompany with their instruments, and the dancers begin the dance. Measured rhythm and pantomimic gestures characterise their movements, and the motions of the eye, which are very singular and conspicuous, play a large part in the art of the performers.

Now comes the viand of viands—the most dainty of morsels—

the bit that is to the Japanese epicure what the green fat of the turtle is to the city alderman, a dish that is none other than a living fish. Resting on a large Cutané dish is a mat formed of rounds of glass held together by plaited threads, on which is a living fish with gills and mouth moving regularly: at its back rises a bank of white shreds resembling damp isinglass, but in reality a colourless sea-weed, while the fish itself rests on green algæ. In front is a pile of small slices of raw fish garnished with a radiating tuft of variegated bamboo leaves. A portion of the raw fish from the pile in front of the living victim is now placed on a saucer and passed to one guest, and so with the rest, till the pile is consumed. Then, to my disgust, the serving-maid, not having enough in the pile for all, raised the skin of the upper side of the fish, which I now saw was already loose, and simply picked up slice after slice from the living creature, which, although alive, had been already carved; nay, even the pile of flesh already served consisted of the lower half of the creature's body. There is a refinement of barbaric cruelty in all this which contrasts strangely with the geniality and loving nature of the Japanese, for with consummate skill the fish has been so carved that no vital part has been touched; the heart, the gills, the liver, and the stomach is left intact, while the damp algæ on which the fish rests suffices to keep the lungs in action. The miserable object with lustrous eye looks upon us while we consume its own body; and rarely is it given to any creature to put in a living presence at its own entombment; but, if being eaten is to be buried, this most miserable of victims to man's sensual pleasure actually enjoyed (?) that rarest of opportunities. This cruelty is practised only by the rich. No living fish ever makes its appearance on the poor man's table; but the infliction of such suffering on one of the lower creatures causes, probably, no self-reproach amongst a people who appear to regard neither pain nor death with dread. As an illustration of Japanese hardihood, I may say, that over seventy persons, two of whom were women, committed hara-kiri<sup>1</sup> only six weeks prior to the date of which I

<sup>1</sup> Hara-kiri does not consist, as many in England suppose, in opening the abdomen,



write, because they had been defeated in a small insurrectionary movement.

With the living fish came on another large saucer-like dish, also of Cutané ware. On this were two kinds of fish, the one browned, the other white, but both baked. A portion of each was served on a large saucer simultaneously with the live quivering flesh; but the living fish is the luxury, and each morsel is dipped in soy and swallowed like an oyster. Feeling that by tasting it I added no pang to the victim, I ate, and certainly in flavour and delicacy this surpassed any of the preceding dishes. The slow and solemn dance, and the weird strains of tremulous music, were a fit accompaniment of a dish so ghastly as that of which we were partaking.

But what have the Japanese to say, I wonder, about our swallowing live oysters? We may argue that an oyster is a creature of low organisation, and that it cannot suffer much pain. What such a creature suffers we do not know, and there is reason to suppose that feeling becomes less acute as the organisation is more simple; yet that by eating live molluscs, and by the treatment which some crustaceans receive at our hands, we inflict pain there can be no doubt. So, perhaps, the Japanese are not much worse than ourselves after all.

The music which now followed was more lively, but still of the same weird character. The girls danced more briskly, and in their pantomimic motions simulated lovers busy at love-making, while boiled slices of bamboo shoots were served as a course of vegetables. These slices were strung on little sticks, from which they were eaten, the sticks serving the purpose of our fork. Then came more soup, with deer flesh in it, as well as fungi, served in covered earthen bowls with pattern in blue and white.

To the fungus employed in the flavouring of Japanese soups

but in thrusting a sword through the neck behind the windpipe with the edge outwards, and then in grasping the sword with both hands, pushing it forward till the throat is entirely severed and falling upon it. The misunderstanding has arisen from the Japanese custom of making certain scratches over the region of the bowels before committing the fatal act, in order to symbolise the reason for their death. A large volume of some hundreds of pages has been written on the etiquette of the "happy despatch."

the characteristic odour of all Japanese things seems to be attributable. In England, all must now be familiar with the smell of Japanese trays, boxes, fans, and fabrics. On taking these soups I could scarcely convince myself that I was not sipping a compound consisting of a small stewed cabinet, a Hakone tray, and a length of Kioto fabric to which a little packing material had been added, with the view of giving body to the liquid. But on the question of food, all nations have prejudices, and John Bull is not among the least bigoted in his views on dietary matters.

Now our music results from two samasins, but one is for the first time played with a bow. This bow much resembles a whip with a heavy lash, the bottom of which is held to the bow by the performer. A fife and a large drum are also brought for our edification, and now we have more lively dancing. Duck with strips of something like Yorkshire pudding are now served, and the diminutive tobacco-pipes are filled and smoked, while every now and again one of the waitresses charges a pipe, the bowl of which would not hold an ordinary pea, and hands it between the tunes to one of the singing girls, who takes one whiff and then puts it down so that it may be made ready for the next performer.

We were now told that it would be polite of us to place small bits of food with our chop-sticks in the girls' mouths, and to throw them the sachi cups; and accordingly we did so. Our trays were now again changed, and we received two black-and-gold covered lacquer bowls, one containing soup, and one rice.

It may here be remarked that it is vulgar to eat much rice at a Japanese feast: the upper middle classes use it as a chief article of food, but to the poor rice is a luxury almost unknown, buckwheat and millet taking its place. Following the rice came a saucer of powdered fish-roe, over which was sprinkled finely cut and delicate looking vegetable stems, like small attenuated celery, but without flavour; our saucers of live fish and other heavy viands being still left. Now followed another bowl of soup, and in it a large light dumpling, and some green vegetables. The music becomes more lively, the dancing more brisk, strange innuendoes not

admissible in English society were indulged in, yet without coarseness ; and while the dance and the repast (which have lasted four hours) were drawing to a close, we were receiving assurances that the highest virtue was maintained by our lady performers. Our jinrikishas were soon bearing us swiftly away to Mr. Mounsey's residence in the Embassy compound.

After staying with Mr. Mounsey to see the New Year in, I went to the house of the Honourable James Saumarez, which is also within the Embassy enclosure, and spent this, the first day of the New Year, in seeing some of the sights of Tokio. Having sallied forth in the direction of the shops, I see the British cortege on its way to the palace (the old palace was burnt down about six weeks since, when about fifteen thousand houses were consumed by fire), Sir Harry Parkes, Mr. Mounsey, and Mr. Saumarez being about to pay their respects to the Mikado. The nobles of Japan pay their homage to the emperor on the first day of the year ;—the ministers and persons of higher order having access to his Majesty, while those of lower rank simply leave their cards. The dress in which these ceremonial visits are paid is the ordinary English evening attire ; and it is indeed absurd to see the ridiculous appearance of some of the nobles owing to the strange cut of their European habiliments. One little nobleman I met walking to the palace in a costume which must have been very uncomfortable. He wore mittens, and the sleeves of his coat were at least six inches too long, hence it was only by a judicious arrangement of folds, and by keeping his elbows somewhat akimbo, that the mittens, which were evidently articles of clothing not to be hidden from view, were kept visible. The legs of his trousers were as much too long as the sleeves of his coat ; while his hat, which was much too large for his head, was kept in its place by a handkerchief rolled into the form of a ball, and carefully placed between his forehead and the rim. This youth was probably, like many other nobles, greatly reduced in circumstances, owing to the changes which have arisen from the overthrow of the baronial system, hence he had ordered his Court suit with due regard to his possible corporal development in the

future. It is a truly pitiable sight, to see fine men arrayed in our miserable dress, and that looking its worst, when the native costume is so graceful, and lends great dignity to the wearer. Every artist will grieve at such a change having taken place, for the Court has thus achieved what we may almost term the national degradation of dress.

This being holiday season, I saw in the streets some tale-tellers, one of whom seemed to enjoy special popularity. Stopping for a time to watch him and his hearers, I tried to gather the plot of his yarn ; but soon all eyes were turned towards me, and uproarious laughter ensued. It was clear that I had now become the butt of his remarks and the unwitting cause of much amusement. "Where ignorance is bliss 'tis folly to be wise." Farther on I came across acrobats, who were certainly clever,—jugglers of great skill, top-spinners who perform wonderful feats, and men with peep-shows for the children.

The morning of the day had been cold, yet bright ; but later the sun warmed the atmosphere, and the scene became more and more gay. From every house hung two or three white flags with the red ball in the centre, and the people flocked into the streets in holiday attire. Many made their way to the great Temple of Asakusa with its vast red gateway, its various shrines, huge coffer for the reception of offerings, tanks for ablutions, odd-looking belfry, and dignified pagoda. I followed in their train, and from the summit of the pagoda got a fine view of Tokio. Beneath us was a space caused by the burning of five thousand houses, only two nights since, the Godowns (fire-proof storehouses) only remaining ; and yonder rose proud Fujiyama with its unsullied cone. The priests seemed to be muttering incantations, boys were beating great drums, fires blazed in the centre of the building, incense was burning, and small coins were thrown by handfuls into the sacred enclosure, while the grounds of the edifice were filled with stalls, on which nick-nacks, prints, sweetmeats, and toys of every sort were offered for sale. I now visit one of the shrines around the great Temple of Asakusa, where, one after the other, the worshippers take hold of the knotted rope hanging in front of the gong, and

by it make the gong produce a booming sound which is supposed to call the attention of the god to the prayer about to be offered. Most stand outside the shrine to perform their devotions, but one man with shoeless feet prostrates himself just within the Temple and remains motionless for a few minutes, with his knees, his hands, and his forehead on the floor. The great game played in the streets is battledore and shuttlecock, and a whole family, father, mother, sisters, and brothers, will knock the shuttlecock from one to the other, till one fails to hit it, when all rush at him, or her, and give a slap with the bat as a punishment. Ball is also a favourite game with the children, while kite-flying is a sport enjoyed by old and young alike. The kites are often in the form of birds; but the strangest are those which, while high in the air, make a hissing sound. These humming kites are always hollow, and are not unfrequently cylindrical in form.

On the moat outside the Castle hundreds of wild ducks were floating. The artillery were practising, and when their guns were fired the ducks rose almost in clouds. In the moat I saw leaves and bent seed capsules of the beautiful Nelumbium, or Buddhist water-lily (Buddha is always represented as sitting on the flower of this plant). In summer the moat must be covered with the gay flowers and broad foliage of this beautiful plant. Oranges not bigger than a cherry are common here.

Going to the railway station I noticed beside the road a baby boy, certainly not more than two years of age, smoking his pipe. I reach Yokohama at six.

On the following morning the sun, which had been shining brightly, was overclouded by ten o'clock, then snow fell heavily. By two the fall was considerable, but all had now become bright as before.

The princes are to-night to leave for Siam, after visiting which country they are to return to China, where I am to meet them about three months hence; so they dine and spend this, their last evening in Japan, with me. During our short intimacy, for it was only on the journey from San Francisco to Yokohama that I had the honour of making their acquaintance, they have shown me the

most friendly courtesy. Both of them have undoubted art taste. Both are well informed on even some of the recondite questions connected with Eastern ornaments, and Prince Liechtenstein has made a most elaborate and careful record of what he has seen during his travels. It is indeed a pleasure in a foreign land to make such friends. At ten o'clock the little hotel boat, gay with lanterns in honour of our illustrious guests, was ready to take them off. The oars were plied, fireworks sparkled in the air, and the boat was soon lost to view.

Next day I stayed at Yokohama to receive Mr. Sano, Mr. Machida Hisi-Nari (the first is what we should call the surname), the successor of Mr. Sano as the director of the Imperial Museum at Tokio, Mr. Tanaka Yoshio, the curator, and Mr. Sekisawa. Mr. Machida offered to show me a wonderful collection of antiquities which are the private property of the Mikado, and are housed at Nara in the building which has contained them for over a thousand years. It was arranged that I should meet him at Nara on about the 26th of this month. He also told me that the Mikado will give me an audience before I leave this part of Japan.

At the incoming of the New Year the native town is entirely given up to feasting and rejoicing. Every house, shop, and cottage is decorated in some fashion or other; but the bamboo and fir-tree find place in all. Two bamboos, with richly foliated tops and about twenty feet in height, are planted in the earth about twelve feet apart, while immediately in front of each stands a branch of the fir-tree. At the height of eight or ten feet from the ground these bamboos are connected by a deep fringe of plaited rice-straw, in the centre of which is a curious group consisting of a crawfish, an orange, fronds of a fern, a plait of straw having the form of a twisted loaf, a row of dried pericimmons on a stick, and a piece of charcoal and a chestnut each wrapped in paper. Grouped in a picturesque manner, these are attached to the upper margin of the straw fringe, from which are also pendent certain pieces of white cut paper—the emblems of the Shinto religion. Some rich persons place at either side of the door simply

three thick bamboo stems with the tops cut off slant-wise, with a piece of a fir-tree in front. In these cases the central bamboo is about three feet six inches in height, those at the sides about three feet, while the fir is about two feet three inches in height. These New Year devices vary, however, in character, but even the poorest of the people seem to crave after a piece of bamboo and of fir, be it ever so small, as eagerly as our poor look for a spray of holly and a bit of mistletoe at Christmas.

The next day I hear at Tokio that the firemen are exercising, and that the sight is worth seeing, so I make my way to the ground. The exercises consist mainly in causing ladders to stand in a vertical position by the aid of hooks which grasp the "rounds," and are driven into the earth, and in the performance of strange acrobatic feats. One man ascends a ladder, and stands in an inverted position, with his head on one of the side uprights; another ascends and, grasping one of the side supports with both hands, maintains himself in a horizontal position; another holds on by his feet, and while his body extends laterally from its support brandishes in both hands a chopping instrument such as is used for destroying walls when a fire is spreading. In short, the exercise consists in the men doing all that "Little Alright," the Japanese acrobat, did when in London. Before each corps of firemen is carried a peculiar device, which being hollow acts as a lantern. It is a sort of badge of the corps as well as a religious emblem, for from each hang pendent the cut papers which symbolise the Shinto religion. Much ingenuity has been displayed in their construction, and I am almost as much interested with these ornamental contrivances as with the exercises themselves.

I noticed that many of the coolies had new clothing, but upon mentioning the matter to a Japanese friend, I was told that all who can possibly afford it buy clothes for New Year's Day. The poor, however, are but scantily clad at best, yet they appear a hardy and strong race. Pantaloons formed of a sort of calico of indigo colour form the only covering to their legs, while a loose blue jacket, on which is either a strongly-defined pattern, or a badge a foot in diameter, constitutes the dress. The feet

are either naked or are protected underneath by straw sandals, but these are far from being durable ; indeed, I have known three pairs worn out in one day, during a long run. Some of the peasant men wear leather coats of buff and rich golden-syrup colour—the lighter tint being that of the pattern with which they are figured. These coats are both picturesque and durable garments.

While we boast of the convenience of our attire, I notice that the Japanese dress has an advantage over mine, in one particular at least. The floors of the shops are covered rather with mats than matting, for the matting is padded underneath to the thickness of an inch or more with straws which are regularly arranged. If a European steps upon a floor thus covered, the high heels of his boots penetrate and spoil the mats. Hence the European has to sit down on the edge of the raised floor and take off his boots, while the Japanese, who wear wooden clogs, can slip them off in a moment without the use of his hands, as they are held on only by a sort of thong which passes between the great toe and its four lesser neighbours, and by a strap which passes over the fore part of the foot.

When out shopping, I was sometimes surprised to see men who, I was told, were English merchants, walk in with their great boots on, and stamp over the floor as though it were their purpose to destroy the mats. The anxiety of the poor shopkeepers under such circumstances was quite distressing, and I have seen a bit of drugget, a common blanket, and other things hastily brought and spread over the mats, to prevent their being ruined by these ungainly visitors. No one, I fear, can visit Japan without perceiving the heartlessness of many of the so-called foreign merchants, and none are worse in this respect than my own countrymen. Some appear to find special enjoyment in annoying the Japanese. Foreigners often speak to the Japanese as if they were altogether inferior creatures ; and if of low class they sometimes treat them as though they were dogs and not men. Such persons do incalculable harm to the country from which they hail, as it is they who make the stranger odious.

On January 6th I left Yokohama to become for a few days



the guest of Sir Harry Parkes at Tokio. Mr. Sano, Mr. Sekisawa, and Mr. Asami met me at the station with two carriages in order to show me some of the places of interest in the city. I now learn that Mr. Sekisawa is to Japan what poor Frank Buckland was to us, and that he is engaged in establishing for the Government a regular system of fish culture. In America he had arranged for the transport to Japan of the ova of salmon and other fish, which he has now just received, and these it is intended to hatch and place in the native streams. The Hamagoten, a palace standing in beautiful grounds which border the Bay of Yedo, was the first place visited. Having been formerly a Daimiô's (baron's) residence it became the summer palace of the empress, while now it is used for the entertainment of illustrious strangers. The building is old and of purely Japanese construction, but the rooms and corridors are covered with European carpets with patterns of little merit. To the European eye the rooms appear to be scantily furnished, as they contain but chairs and tables, and while the chairs are of black lacquer they are of the old round-backed pattern which was common with us some twenty years since both as a dining-room and bedroom chair.

In the garden surrounding the palace is a lake of the greatest purity, a running stream, and a small waterfall, while over the stream is a most curious bridge, for when half across the water the bridge turns at a right angle to the left, and then again continues its former direction, while a railing which is only placed at one side of the bridge is on the right hand up to the bend, and then continues on the other side.

Surrounding the lake are a series of mounds on which stand diminutive, yet old, trees, and from the top of every mound the bay of Yedo is in full view. One old and gnarled pine-tree, the branches of which descend and wind amidst rocks, is almost snake-like in its character. Such trees are particularly admired by the Japanese, as they remind them of the drawings of the dragon winding its way amidst stones and rocks, with which they have been familiar since their earliest infancy.

Stretching far over the lake, and supported on a light bamboo

trellis, is a westeria creeper, which when in blossom must look perfectly charming ; but what interests the Japanese most is the fact that the whole grounds represent a Chinese landscape in miniature.

We next visited the beautiful temple of Uyeno, where, as at Shiba, the main building has been destroyed by fire. What remains is indeed splendid ; but while the buildings left standing are in some respects not quite so fine as those of Shiba, the rows of great lanterns (each pair of which has been given by some Prince or Daimiô) are finer.

Having described one of the great Buddhist shrines of Tokio, I will not attempt here to give any details respecting that of Uyeno, as I shall have to notice it when speaking of the architecture of the country. Its character may, however, be judged of from the two ceilings shown in Figs. 17, 18.

In the evening there was a party at the Embassy, for it was old Christmas Day—the 6th of January. The Prime Minister—Mr. Sanjo Saneyoshi, with his wife and his deputy—Mr. Iwakura, were present, and other great personages, ladies and children,—the latter being entirely in Japanese dress.

For the ladies and children, presents were arranged on a large Christmas tree which filled the centre of the hall ; the Japanese gentlemen were amused by a magic lantern having views of European cities and buildings. The European guests danced. The Japanese never themselves dance, as they can hire others to dance for them. The Court ladies who were present in their native costumes looked very gay and interesting : one dress in particular I thought peculiarly beautiful. It was more of a robe than what we know as a dress ; its ground was white, but over the surface were strewn little summer-like flowers in the softest of varying pinks, with here and there a speck of tender green, while the whole was rendered lustrous with gold. The hair of all Japanese ladies is jet-black, and most of them this evening had it dressed in Court fashion, spread into a large flat butterfly-like bow of less than an eighth of an inch in thickness.

The next few days I spent in wandering about Tokio, looking

at shops, picking up art objects, and watching the amusements of the people ; on the 11th we had a slight shock of earthquake.

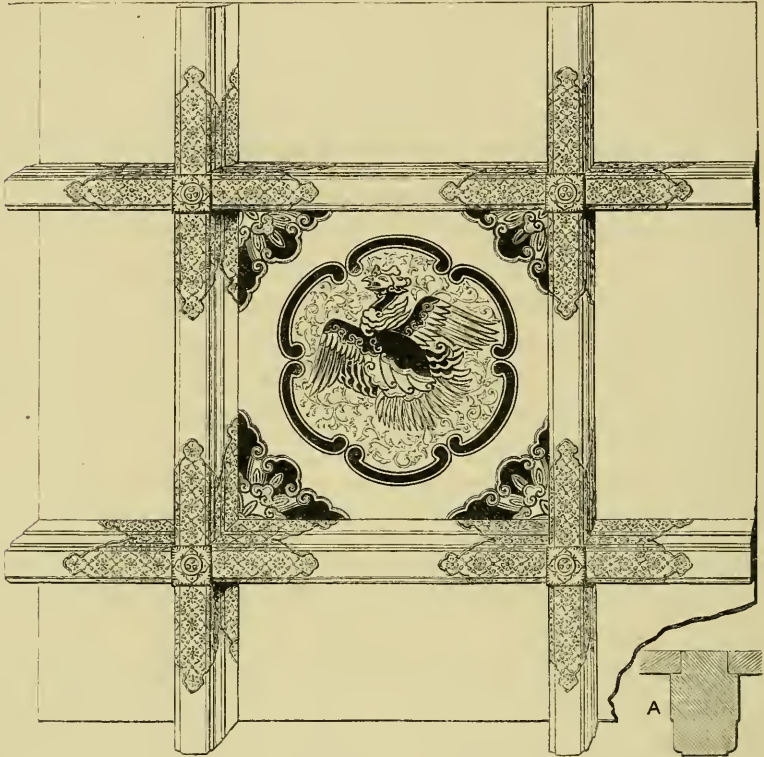
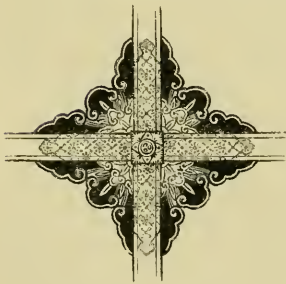

FIG. 17.—A CEILING IN THE SHRINE OF THE SHŌGUN TOKUGAWA IYEMITSU.

It was built in the year 1681 in connexion with the Buddhist temple at Uyeno.

A. gives the section of crossing members. B. gives the ornament at the crossings complete.



B.

At one o'clock on this day Sir Harry Parkes was to take me to Mr. Okubo, the minister of the interior ; but finding that the mail was leaving he got the appointment deferred till the following day. In the afternoon we viewed a small Shinto temple, erected to the memory of the Mikado's soldiers who fell in the revolution of 1868 : it is a building formed of plain uncoloured wood, in the centre of which is a slightly raised dais bearing a large European mirror and a small

vase formed of a joint of bamboo and filled with flowers. The floor of the temple is covered with a white ground common Brussels carpet of large panel pattern; on the dais is spread a more hideous European white felt carpet. Besides the mirror the temple contains about eighteen caned European arm-chairs.

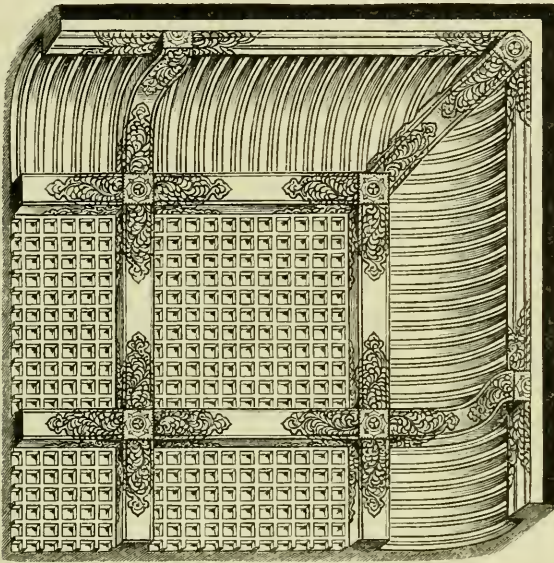

FIG. 18.—PART OF THE CEILING OF THE TEMPLE OF UVONO IN TOKIO.  
From a model presented to the Author by the Japanese Government.

This temple is situated on high ground close to the race-course, from the bottom of which we get a splendid view of Tokio with the bay beyond. The aspect of the city is very remarkable, as the Castle rises conspicuously in the centre of the town. The streets being broad, and the majority of the houses only one story high, the space occupied by Tokio is very large. All Japanese houses, when seen in masses from above, have rather the aspect of hovels or a thatched Irish village, than of English towns. It is only when we view them in detail that we see their beauties, and in many cases it is the interior which is calculated to charm rather than the external aspect. Turning round to re-enter our carriage, we see proud Fujiyama rising as a rich purple cone drawn

on a glowing sky, although it is distant some sixty or eighty miles.

On the next day I went with Sir Harry Parkes to pay our visit to the Minister of the Interior. Mr. Okubo is a man of unusual stature even for a southern Japanese, and is more than a head taller than the average Tokio man. His bearing is dignified, and his manners are less set than those of some of the ministers, while his conversation is most homely and genial. His house is a European building, like those now fashionable with the higher Government officials. The room into which we were shown was upstairs, and was carpeted and furnished in European style.

Here the servants do not prostrate themselves before the Minister as Japanese servants usually do, but behave as Europeans. Mr. Okubo is in European dress, and so are both Mr. Sano and Mr. Asami.

Our conversation turned chiefly on the native art manufactures; and the Minister requested me to draw up a report on Japanese commerce with Europe, and the means by which it may be increased. During my visit I called attention to the fact that much might be done in the way of preventing the disastrous fires with which Tokio is so frequently visited, by compelling all owners of houses to saturate the wood used in their construction, and the paper of which the windows are formed, with tungstate of soda, or some allied chemical substance. The fires in Tokio are most disastrous. Indeed, it is said that a number of houses equal in number with those forming the entire city are destroyed every ten years by fire.

Mr. Okubo, although the Minister of the Interior, is, in reality, the leading spirit of Japan. He took an active part in the revolution of 1868, in which the Mikado was brought from his seclusion and restored to the government of his people. Mr. Okubo fought his way to power, and when the Mikado assumed the reigns of government was raised to the high office which he now holds, and which he justly won by his prowess in the field.

To Mr. Okubo is primarily due what we may call the introduction of a European civilisation into Japan. And no man

could have been more alive to the value of certain European contrivances than this accomplished minister. Japan now boasts a telegraphic system as perfect as that of any European country ; its coast is rendered safe by numerous lighthouses ; its postal system is being rapidly developed ; the streets of some of its larger towns are already lit by gas ; steam fire-engines have taken the place of useless little pumps ; a regular system of police has been established ; two railways have been constructed ; good roads are being made, and excellent bridges built ; and all this may be said to be due to Mr. Okubo. I may perhaps be permitted to mention here certain facts respecting Mr. Okubo, although they did not occur till after my return to England. I shall have occasion to refer to him but rarely in this book, he being now dead.

After my return to England I received from Mr. Okubo a letter which was shortly followed by another from my friend Mr. Mounsey. Of Mr. Okubo's letter the following is a copy, while from Mr. Mounsey's I extract the passages which relate to Mr. Okubo's sad end, and to the report which he requested me to write :—

*“ 26th of 3d month 11th year Meiji.*

“ DR. DRESSER.

“ Sir—In January of last 10th year Meiji, you have brought the articles sent by Mr. Owen to our museum, and I am much obliged that you have taken the trouble to arrange them. After your returning home last April the articles have been exhibited to all the people, and I have notified all through the country your valuable informations regarding to the important points of industry, which you have given to the officer who attended you during your visit to several industrial establishments. It must be for your kindness that I could make all industrial men to understand the points which were obscure heretofore, and I can assure you that in the future time they will make a progress and bring that interest upon the commerce.

“ During your visit you have requested our museum to make the models of ornamental ceiling of several temples at Tokio, and now they have been finished.

“ Although they are very trifling and not enough to compensate your last service, I present them to you through Mr. C. J. Strome, and you will please accept them as the token of my highest regard.—With compliments,

“ OKUBO TOSHIMICHI,  
*“ Minister of Interior Department.”*

“ YEDO, *July 9, 1878.*

“ DEAR DR. DRESSER—I have to thank you very cordially for your kind letter of the 17th May, as well as for its most interesting enclosure—the report which you have addressed to Mr. Okubo. You will have learnt by the papers that that gentleman was brutally assassinated on the 14th of the same month as he was driving to a Cabinet Council at the Mikado’s palace. His carriage was stopped by six men armed with the sharp deadly swords you know so well, who had been lying in ambush for him. They first hamstringed the horses and killed the coachman. Poor Okubo tried to get out of his brougham; there were two men with drawn swords at the door, he tried the other side—there were as many there too. A fearful moment the poor man must have had when he thus saw death on all sides. They pulled him out and hacked him to pieces, and then went and delivered themselves up at the Palace, proclaiming that they were actuated by purely patriotic motives. Since then all the ministers are accompanied by escorts of mounted men, who ride with drawn swords. Ito has succeeded Okubo, and he told me the other night that he had just received your report, but had not yet had time to digest it.

“ . . . I must now congratulate you on having so clearly pointed out to the Japanese Government the sort of way in which they can augment their exports. With regard to the articles which you instance as certain to sell in our markets, they ought to be most grateful to you for the care you have taken in their description. . . . I think and hope that the Japs will find your information so valuable that they will ask your advice again before long. Sir Harry Parkes begs me thank you for having sent it to the Legation, and thinks its contents most useful and valuable. Saumarez read it with great interest, and agrees with me in admiring your story and the way you tell it, and I may add that Mrs. Mounsey perused it with much pleasure. . . . Mrs. Mounsey desires to be kindly remembered to you, and I remain, yours truly,  
AUG. H. MOUNSEY.”

This was indeed a sad ending to a great life, and the effect of his removal from the work which he had in hand cannot yet be accurately estimated.

The receipt of my report was acknowledged by Mr. Okubo’s successor, who warmly thanked me for the trouble I had taken in its preparation.

My time during the next few days was occupied chiefly in paying necessary visits and in studying the manufactures. One of these visits was to Madame C. de Struvé, the wife of the Russian Ambassador (now, I regret to say, deceased). This

lady was an assiduous collector of teapots, of which she had more than seven hundred specimens, no two being alike.

On the morning of the 16th January General Saigo and Mr. Asami called to take me to the arsenal, the mint, and some other important places. Mr. Asami kindly acted as interpreter. The arsenal occupies a portion of a garden arranged two or three hundred years ago by a family from which the last Shōgun sprang. In the buildings of the arsenal I heard the hum of machinery for the first time in Japan, and I cannot help feeling that while the art of war may be encouraged by its aid, the arts of peace and industry can only thereby lose the charms which they have hitherto possessed. In the factory guns were being made and small arms altered, but all this had but little interest for me. In the first place, there was no art merit in the things produced ; and in the second, the processes employed were all European.

The garden surrounding the factories is, however, very beautiful, and, like many of the most celebrated in Japan, represents in miniature a Chinese scene. In the garden are some lovely summer pavilions, their little lattice windows being most charming in design. Yet these are all perishing for lack of attention, while the lattices are falling, bit by bit, upon the ground. It is indeed lamentable that such exquisite structures should go to ruin, yet I fear that European civilisation is likely to prove fatal to some of the finest monuments of the country : but why it should be so I cannot divine. No nation can afford to do away with its ancient monuments. If they are of great excellence in design they tend to uphold the character of national manufactures ; and by attracting visitors to a country the money which they spend in the land contributes to its wealth. I feel sure that if the magnificence of some of the great temples and shrines of which Japan can boast were widely known, many would journey even from Europe to see them ; but while some of the temples are beautiful beyond all description signs of decay are but too apparent in almost all.

From the arsenal we went to the great Confucian Temple, which, up to the time of the revolution in 1868, was the



Japanese university where 4000 students—the sons of nobles and daimiôs—were educated.

Confucianism, I need scarcely say, is in no way a religion ; it has no concern for a future life, of which Confucius said that he knew nothing. As a system of ethics it provides only for the relation of man with man. The classics of Japan, as taught in the universities, were all Confucian writings. The Japanese had no natural sciences although great observers of nature, and their knowledge of mathematics was small. This great Confucian Temple was to Japan what a university such as that of Oxford is to us, and the glory of the building resulted, as the Japanese express it, from its being dedicated to learning.

Now all things are changed. The students are dispersed and the university is no more. The study of the natural sciences, of mathematics, and of languages, has replaced that of Confucianism, and European professors have supplanted the learned men of the nation ; but the wheel of fortune is again moving, and Japanese professors are teaching the natural sciences which they have learned from Europeans.

As a building the great Confucian Temple is in a high degree sombre, consisting internally of nothing but black lacquered wood : the columns are black, the walls are black, and the ceiling is black ; and the only relief which is given to this monotony is afforded by the bronze sockets which encase the bases of the columns ; yet even these are dark in colour. In one particular, however, this edifice differs from all others that I have yet seen in Japan, for its roof is of open structure (no ceiling), while in the carving (though this exists in but small quantities) representations of animals are much more common than those of plants.

This edifice is now the great national library of Japan, and here are already collected some thousands of volumes, a catalogue of which was kindly given to me by the worthy librarian.

Leaving the university building we visited a large temple which seems to have but few worshippers ; but here I was pleased with the almost interminable passages, the numerous rooms, and sweet little gardens connected with the building. On

the altar stands a pierced earthen vessel of celadon ware, which is lined with brass and contains the ashes of burnt incense ; and here also rests a carved branch of the *Nelumbium* (the Buddhist lotus), strikingly Egyptian in character (Fig. 19). To the likeness

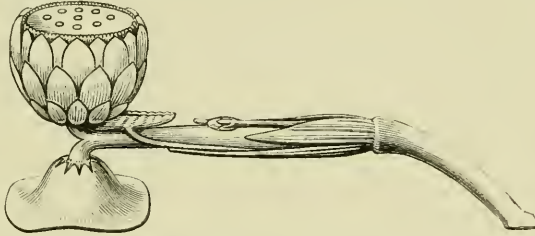

FIG. 19.—OBJECT CARVED IN IMITATION OF A SPRAY OF THE BUDDHIST LOTUS.  
Buddha is said to hold this in his hand when he prays for his mother.

subsisting between the arts of the ancient Egyptians and that of Japan I shall have frequently to call attention.

We now visit that portion of the mint in which Japanese bank notes are printed ; but here the subtleties of electric etching and European methods of printing are practised. At the arsenal, at the mint, and at one weaving factory in Kioto which I visited some weeks later, European mechanism was employed ; but in no other instance did I see any indication of the native methods being superseded by European appliances.

The next morning was occupied chiefly in seeing the things unpacked which I took out from England to the National Museum. Nearly all, happily, proved to be in sound condition.

The sky this morning was overcast, and by eleven snow fell ; but at five in the afternoon the heavens were once more cloudless, while, later, there was a glorious sunset. The night was bright, cold, and starlight.

*January 18.*—This morning I went with Mr. Mounsey to Yokohama by the 8.15 train, where we engaged jinrikishas to take us to Kamakura, a town about seventeen miles distant on the other side of the promontory which forms the southern boundary of Yedo Bay. The road is of a very imperfect character, and lies through a long valley of rice-fields, while in one place it passes over a high bluff. In Japan the rice-fields in some cases

extend for many miles together, and are even terraced on the sides of the hills. This terracing of nearly empty mud-ponds, for such the rice-fields look at this season of the year, as the fields are all sunk below the banks which separate them, and the water has run off from the soil, gives to the landscape a strange aspect.

Rising from the valley as we approach its head, we come to the bluffs or sandbanks which seem to separate the land at the north side of the promontory from that of the south. This bluff resembles the sandbanks with which we are familiar at Scheveningen, Ostend, and Deal: and like these is filled with the roots of the *carex* or sandgrass. It may be worthy of remark that Japan has no true grass which will serve as fodder for sheep. The rough *carex* covers much of the country; but as this dies down to the ground in winter many hills become bare during the cold months of the year, and give an uninteresting character to the landscape. The absence of grass causes mutton to be very dear in Japan (it is about 2s. 6d. per pound in the open ports where alone meat of any kind can be had, save in one or two of the largest towns in which European ideas are being adopted), for the sheep have to be fed in China and taken to Japan. Beef, however, is only 5d. per pound, as oxen will eat the coarser food.

In order to ease our coolies we walk over the bluff, and they follow with our tiny carriages; but after passing the summit the road becomes narrower and narrower till it disappears altogether. A by-path traversing a bank which separates two groups of rice-fields is the highway over which our jinrikishas carry us; but as this road is cut by many watercourses bridged over only by two stones the ride becomes exciting, for we have often to consider whether the space between the wheels of our jinrikishas is greater than the width of the bridge.

These little difficulties surmounted, we come upon what was once a great city—the town of Kamakura. This town is now little more than a village, although larger than Yedo at one time. It is situated on a lovely island-studded bay, the sands of which are rich in shells, and reminds me of Bantry in Ireland. Here is a temple recently restored and somewhat vulgarly re-

decorated which boasts of presents received by the first Shôgun from the Crown as far back as the year 1180 ; but our pilgrimage is to the Great Buddha or Dai-butzu.

We soon approached richly wooded land, and through an opening in the trees beheld the colossal figure. This Dai-butzu, formed of bronze, is forty-seven feet in height, although in a sitting posture. It has been formed of parts of about six feet square, which have been brazed together, and thus the whole figure now consists of one huge mass of metal. Figures of Dai-butzu rest usually on a lily (the flower of the *Nelumbium*) ; but in this case the base is represented by only two petals of the flower which lean against the wall to the right and left of the figure, for it has never been completed. The figure sits in dignified repose with a most placid expression of countenance. From its forehead protrudes a boss representing a jewel from which light is supposed to flow, and which symbolises an idea similar to that expressed in our Scriptures—"I am the light of the world." The hands of the figure are so placed that the thumbs meet at their points, the backs being downwards, while the fingers assume a vertical position. The figure is draped in a graceful manner, leaving only the bosom exposed. In front of it stands a table-like altar, on which rest two bronze vases, a bronze censer, and two vessels for flowers. The bronze vases each contain a group of leaves and flowers of the Buddhist lotus (the *Nelumbium*), which have been beautifully modelled and charmingly cast. The altar is six feet in height, while the brazen lilies with their vases are even higher still ; yet the altar with its flowers looks small when compared with the vast figure against which they are seen. To the right and to the left of the figure there is a bronze pedestal-lantern, of about ten feet in height. Having carefully inspected this figure externally we walk into its interior, for it is hollow, and is fitted up within as a shrine or chapel. On approaching the altar we see the results of an act of snobbery which is in the highest degree contemptible ; for on the forehead of one of the figures which stands upon the altar some English or American cad has written his name in ultramarine blue.

An act so disgraceful cannot be too strongly condemned. I cannot help feeling that only a snob of a very low type would write his name on any work of art, but when a sacred altar is thus desecrated the offender would be fitly punished by being dragged at a cart-tail and whipped through the town.

Climbing the ladder, we ascend to a platform within the figure, from which a view of the surrounding country and bay can be had through an opening in the head, and afterwards descend to luncheon in the open air.

With the back of a grouse in one hand, and bread in the other, I wander around the figure, and notice over the shoulder-blades two large metal loops, the nature and object of which I fail to understand. Mr. Mounsey, as much puzzled with them as myself, appeals to his native interpreter and asks their use. The question is at once answered by the words "for the shine," but as this throws no light upon the matter, we ask how the word is spelt, when the reply is s-h-i-n-e. Varying the question in every possible way, we only arrive at the one answer, "for the shine," and with this we are obliged to be content.

To the right of the Buddha is a little stall such as we often find at religious places in Japan. This stall is attended by a priest who sells drawings of the sacred figure, maps of the district, charms against evil, pictures of Daikoku—a favourite god of Japan—and other sacred prints. The cost of these things is but trifling, while the figures sold are in some cases of great interest as they reveal the origin of certain symbols which are common to Buddhism and Christianity. The evils from which immunity can be purchased by the charms are of almost every kind; but the charms appear to me to be simply folded bits of paper of about four inches in length and one inch in breadth so gummed up that they cannot be opened, and bearing an inscription which specifies the evil guarded against, and a red stamp, which may be said to be the sacred seal of the temple. One of the charms which I bought was against smallpox, another against the dangers of travel, another against evil generally, and so on; but the ailments

to be averted by a small expenditure at this holy spot are legion.

On our homeward journey we visited a temple of great importance, adorned with images of the five hundred disciples of Buddha—and strange indeed they look—as well as by three magnificent wood-carvings by one of the greatest carvers that Japan has ever seen, and some beautiful lattice-work.

We were on the point of leaving this edifice when our interpreter, with beaming countenance and excited manner, pointed to an image straight before us, and exclaimed “The shine! the shine!” We now understand what he attempted to explain when we were viewing the great Dai-butzu, for the head of this figure is encircled by a Nimbus, and what we saw on the shoulders of the great figure were the fixings for this appendage to the colossal figure at Kamakura.

We had scarcely re-entered our jinrikishas when our interpreter insisted upon our alighting at a tea-house, in spite of our protestations that we had just fared sumptuously. Although he had shared what to us had been an ample meal, he seemed dissatisfied with the cake and tea now offered to him, and ordered three raw eggs, which were speedily brought in a saucer, together with some soy to serve as a sauce. Taking the eggs from the saucer he placed them on the floor, and breaking the shell of one he poured its contents on the dish, adding a little soy, and putting the saucer to his mouth, swallowed the morsel as we should an oyster. Having treated the others in the same way, he drank sundry cups of tea, and then said calmly that he was ready for the journey. This little freak of our worthy interpreter was the more remarkable as the Japanese eat often and but little at a time; indeed, Japan is a land of littles. Their most beautiful objects are generally little: the knob of a stick or the button (*netsuki*) of a tobacco pouch is often an artwork of the highest elaboration, and their dainty foods are served in small portions. Possibly the country air gave our guide an unusually good appetite. On our asking what should be paid, the interpreter explained that to ask for a bill would give the greatest possible offence to a Japanese

hotelkeeper. You never pay, you simply give ; and the present for the light refreshment of tea and cake would be about twopence or twopence-halfpenny in our money.

We return to Yokohama by road, and reach Tokio by a late train.

A message respecting my presentation to the Mikado was brought to me next day by Mr. Sakata, an old friend whom I had had the pleasure of entertaining some years ago at my house in London. The meeting was a pleasure and a surprise to both, as when he came to make his official call he had not the slightest expectation of seeing his old London friend, thinking it was some one else of the same name, nor I of seeing him. His message was that the Mikado would give me audience at two o'clock on the following day. He said that it was to be a private interview, and gave me a copy of the speech which the Emperor was to make, asking me to be ready with a short reply. Of this speech I asked Sir Harry Parkes to let me have a translation.

*January 20.*—Morning as fine as ever, sky almost cloudless, sun bright and warm.

The following is the English of the address which the Mikado is to make this afternoon :—

Speech of His Majesty, the Tenno (ten-Heaven, no-Emperor ; also called Tenshi, Ten and Shi-child), to Dr. Dresser, January 20, 1877.—“We shall long preserve in our memory the remembrance of a collection of articles manufactured in England and other countries, having been made at the South Kensington Museum in your country, and presented thereby to the Japanese Museum ; and also of your own kindness in coming to Japan to display to the eyes of our people the nature and appearance of articles manufactured in Europe ; and to point out to their minds the road leading to advance and improvement of arts. We trust that your visit to Japan may be free from accident, and a pleasant one.”

To this speech, which is said to be longer than the speeches of the Mikado usually are, I prepared the following reply :—

“I feelingly appreciate the honour which your Imperial Majesty has done me in giving me a personal reception.

“The small present, of which I have been the bearer, to your Majesty’s National Museum was got together at the suggestion of Mr. P. C. Owen, the director of the South Kensington Museum in London. For the objects I am indebted to Messrs. Londo and Co., who gave the greater number, to Messrs. Green and Nephew, Messrs. Doulton, Messrs. Elkington, and Mr. Jno. Lewis, all of London; to Messrs. Jno. Brinton and Co. of Kidderminster, and to Messrs. Ward and Cope of Nottingham.

“For years past I have been an admirer and collector of Japanese objects, and the greatest desire of my life is now realised in visiting your Majesty’s most charming country.

“I humbly beg that your Majesty may be pleased to order the adoption of such means as will preserve to your Majesty’s people their national arts in a form unpolluted by European influences, for the ornamentists of our western countries feel that it is their privilege humbly to follow the great artists of your Majesty’s dominions.

“If your Majesty will allow me the honour of so doing, I will from time to time forward to your Majesty’s National Museum specimens of our most recent manufactures, and if I can be of any service to your Majesty’s industries, or be the means of promoting the commerce of your Majesty’s country, either during my stay here in Japan, or when I have returned to England, I beg that your Majesty will allow me the honour of placing my services at your Majesty’s disposal.

“I thank your Majesty most humbly and sincerely for the great honour you now do me.”

About 11 o’clock this morning Mr. Sakata called for this answer, so that it might be translated for the Mikado.

Arrayed in evening dress according to my instructions, I was taken by Mr. Tanaka, the vice-president of the museum, and Mr. Sakata, who was also in English evening dress, to the palace, which is a ten minutes’ drive from the Embassy. At the outer gate sentinels gave us the European royal salute,



and driving through a garden, we passed a second gate and drew up under the portico. Here large low doors stood open, and four servants conducted us along the corridors of the house, at one side of which is a boundary-wall and the other window-like "slides."

The temporary palace of the Mikado (for the old palace was recently burnt down) is a large Japanese house (*yashiki*) of the usual simple construction and one story in height. The passages, and such rooms as I saw, have their floors covered with European carpets—some tapestry and some Brussels, but in most cases the pattern is such as we should consider artistically bad. An ante-room into which we were shown had a black slate chimney-piece decorated with coloured ornament and an open European grate. The wall slides, although of Japanese character, were covered with a cheap French wall-paper, and the ceiling had a paper of similar character with an elongated geometrical pattern. In the centre of the room was a table over which fell, in ample folds, a cloth of soft low-toned green-yellow colour enriched with the figures of dragons arranged as circular devices. The circles, about six inches in diameter, were irregularly distributed over the surface of the cloth, so that, in some cases, they came nearly together, while in others they were four inches apart. On the centre of the table stood a cigar-box. The carpet was of miserable pattern. Around the table was arranged six European chairs with carved ogee legs and curved and open backs. The seats of these chairs were covered with terry silk of imperial purple colour, and figured with a pattern in velvet or plush, and when this velvet figure was looked upon from above gold was visible in its ground. By the side of the table stood a *hibachi* (or fire-holder) of simple character, the stand of which, worked in plain pine-wood, consisted of a hoop about three inches wide (resembling the hoop of a sieve) at the top, three legs, which were attached to it, and a circular disc fixed, like the hoop, between the three legs, but about two inches below it. On this disc rested the brazen *hibachi*, while the rim, by encircling it, prevented its falling. The stand of the *hibachi* was of such a height that the fire

was brought to almost the same level as the table, and through the legs spreading in a downward direction the danger of upsetting the fire was diminished. This was the entire furniture of the room.

Two gentlemen in gorgeous Court dresses now enter our room, one being favoured with a little more gold lace than the other. Having been presented first to the latter, who is the minister of the household, then to the former, who is the master of ceremonies, I am now conducted by them to the throne-room, where I am to be received by the Mikado. It is a long, narrow room, having its two sides formed of paper slides, the end at which we enter open, and the opposite end closed by a solid partition. My instructions are that I am to come to a certain spot at the centre of the open end and bow; that I am then to advance one step and bow again; that I am then to take about four steps—to advance three yards—and bow again. The only piece of furniture in this room is a European arm-chair, evidently belonging to the same suite as the small chairs in the anteroom, and covered with the same material. This throne stands in the centre of the distant end of the room in front of the solid partition.

We now return to the anteroom, when, in about two minutes, the minister of the household, who had remained behind, enters and says that the Mikado will see us. Mr. Tanaka walks first, I second, Sakata last. Mr. Tanaka does not, however, enter the royal presence. Following my instructions as to bowing and advancing, I find myself about eight feet from the Mikado.

On my right, and close to the wall (or wall slides), and a little nearer the Emperor than I am, stands the master of ceremonies, while on my left, and opposite to the master of ceremonies, stands the minister of the household: both have bowed three times as we have done, and both, having taken their places, stand with bowed heads.

The Mikado looks to me to be about twenty-seven years of age, is of medium height for a Japanese (short for us), wears a solemn expression, and stands, as I see him, in a slightly stoop-

ing posture. He wears a European military dress, bright with gold lace.

When we entered the throne-room he was standing with his face towards us in front of his throne. He bent his head slightly but did not bow, and at once began to read his address (Fig. 20), audibly, distinctly, and apparently with feeling. Knowing that I could not understand the language in which he was speaking, he

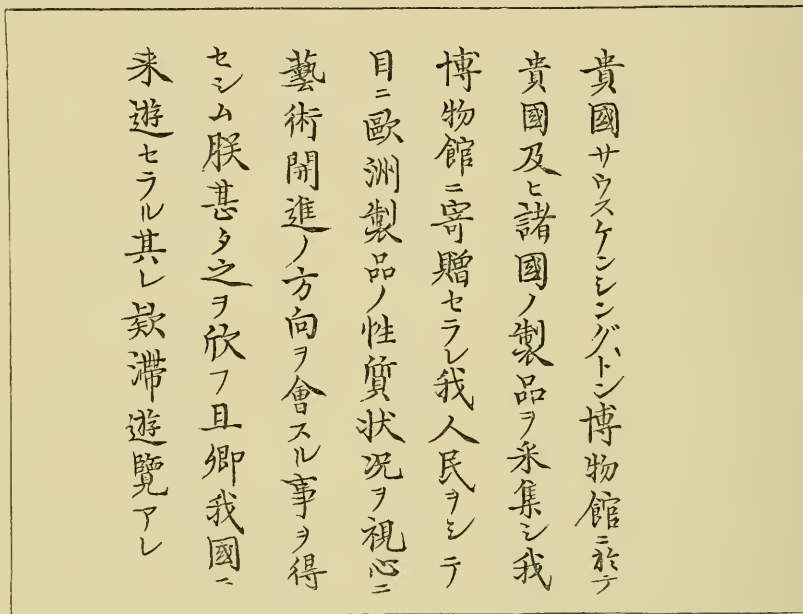

FIG. 20.—FACSIMILE IN REDUCED SIZE OF THE VERY ADDRESS FROM WHICH THE MIKADO READ.

The day following my reception by the Emperor, His Majesty sent me the very paper from which he read as a special compliment. My interpreter informed me that this is the first time that such a thing has been done to any foreigner.

must have been aware that he was wasting his royal "sweetness on the desert air," yet his manner in no way indicated any impatience. I now read in English my reply to His Majesty's address, and then handed the translation of it to my interpreter, who read it to the Emperor in soft and respectful tones, being only a little puzzled with some of the European names. This done, we bowed and walked backwards out of the royal presence.

When we had re-entered our carriage, and departed after a royal salute from the guards, Mr. Sakata informed me, by request of Mr. Tanaka, that to them the honour of driving to the palace door is very great, for no Japanese, save a minister of state, or a personal friend of the Emperor, may do so ; and even then they are not permitted to enter by this door, which is reserved expressly for honoured strangers.

Thus, then, I have gazed on a man who is still in the eyes of his subjects the son of the Gods and the Emperor of Heaven. Things are strangely changed, for only a few years back the subject, to say nothing of a foreigner, would have paid for this sight with his life.

My next outing is to a Japanese theatre, but, unfortunately for me, the three chief theatres of Tokio have been burnt in the fires which have lately wrought so much destruction in the city ; and as the great actors never act in one of the minor theatres of the capital I have to judge of the Japanese drama in a second-class house, and from a second-rate company. The theatre is a curious building, the exterior of which it would be difficult to describe as it bears but little resemblance to any European edifice, and the entrance is overhung by pictures and flags arranged somewhat in the manner of a canopy. Internally the building is a parallelogram, with a ground floor and a gallery, much in the fashion of a Methodist chapel in a small English

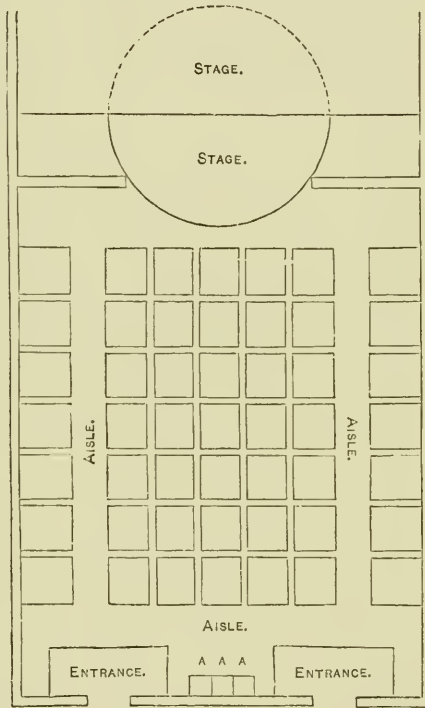

FIG. 21.—GROUND-PLAN OF THEATRE AT TOKIO. Showing Circular Revolving Stage. A A A, Stalls where tickets are sold.

town. I ascend the stairs and enter a box. But let no one for one moment suppose that the box of a Japanese theatre has any likeness to that of a European opera-house. Both the floor and the gallery of the Japanese theatre may be said to consist of boxes, which yet are rather pits than boxes. Their character and



FIG. 22.—SECTION OF BOX OR PIT OF THEATRE. The tops of the partitions (A A) form the Aisles.

arrangement will be better understood if I compare them to a series of regularly arranged "pens" in one of our cattle markets.

There are two entrances to the theatre, one to the right and one to the left of the street face, with earth as their floors, and level with the road. Here the native clogs are left, and the visitor purchases his ticket. A platform, running across the whole width of the theatre, is extended downwards throughout the length of the building as two aisles, which in their turn meet a transverse platform at the inner end of the house, which may be regarded as an extension of the stage.

To the right of the aisle, or to the left, as the case may be, and arranged close to the wall, is a series of boxes, pits, or cells, whichever we may call them, and square in shape. These boxes are separated from one another by narrow branch

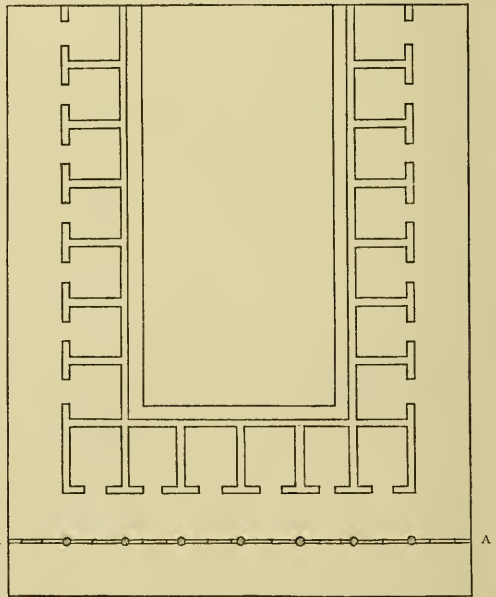

FIG. 23.—PLAN OF GALLERY OF THEATRE AT YEDO. Behind the bamboo screen (A A) the "gods" stand.

aisles, and have their floors level with the street; thus it may be said that the places assigned to visitors are seats in square pits

about fifteen inches below the level of the aisles, and into which you jump when you take your place, rather than boxes such as we have in our theatres. At the opposite side of the theatre is a similar row of boxes, and between the two principal longitudinal aisles are arranged in rows a considerable number of these square boxes, while the gallery is portioned out in a like manner (Figs. 21, 22, 23).

It is curious to see the visitors walking along the broad aisles and then balancing themselves on the narrow planks which are only the flat tops of the partitions separating the boxes; and it is equally strange to see the people kneeling on the matted floors of their little cells in family groups sipping tea, eating sweets, or even boiling water in a kettle.

The stage is seen from the auditorium almost precisely as our own, but its back is formed of a plain curtain, and all the scenery consists of actual models of the objects required; houses nearly as large as ordinary dwellings, and trees and other things in proportion, being placed on the stage. When the scenery has to be changed, it becomes apparent that the stage is a vast circle swung on a central pivot, and that as much of it is behind the curtain as is in front. This arrangement has one advantage, for while the play is going on new scenery is being arranged on the distant half of the stage; and to change the scene all that is necessary is the pulling up of the curtain and the twisting round of the stage. There is this further peculiarity in a Japanese theatre, that the actors enter behind the audience, coming through black curtains with white figures, near the doors where the public enter. It must also be remembered that no women are employed on the Japanese stage, men taking women's parts as well as their own.

Having entered, the actors advance along the main aisles, acting during their progress, till they reach the inner end of the platform and the adjoining stage. I saw a horse brought along this aisle, which was a make-up exactly after the fashion of our stage horses. Behind those boxes in the gallery which face the stage is a screen formed of vertical and horizontal pieces of

bamboo, at the back of which poor persons stand, and through which they look at the performance. In the way of decoration,

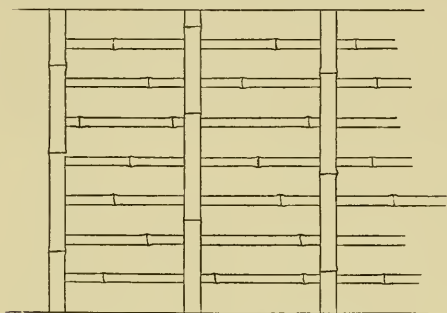

FIG. 24.—ELEVATION OF BAMBOO SCREEN (A A, Fig. 23), through which the "gods" look.

we have strips of richly-figured cotton cloths hanging from the galleries and from the ceiling in such numbers that from my position in the corner of the gallery I am unable to discover the nature of the roof which covers us.

The theatre opens at six in the morning, and closes at from six to nine in the evening, and a Japanese will go with his wife and family, taking provisions with him or getting them there, and remain the whole day.

Of the acting I can say but little, for in the first place my visit was short, and in the second for the perfect understanding of the piece a more intimate acquaintance with Japanese usages than I then had was needed. However, it altogether surpassed my expectations, and it was better than much that we see at our own play-houses. On the morning of the 22d I took my leave of Sir Harry Parkes, and returning to Yokohama, there found Mr. Arnold Crossley of Halifax.

Hearing that Mr. Sano had prepared a great treat for me, asking five of the greatest artists of Japan to his house for the purpose of making sketches, Sir Harry and Lady Parkes, Mr. and Mrs. Mounsey, and Mr. Crossley, expressed a wish to be present. Mr. Sano kindly assented.

The room in which we assembled to see the artists is of considerable size, and is one of those which Mr. Sano has not furnished in the European manner. The artists kneel upon the floor, which is covered with mats, as is usual in a Japanese house. On the centre of the floor is spread a piece of red felt, on which, held down by weights, rests a sheet of paper, which is smooth and yet of a somewhat bibulous character. The tools of each

artist are a small piece of charcoal held in a light bamboo porte-crayon, about fourteen inches long and very slender ; flat brushes formed of deers' hair, varying in width from three inches to one inch and three-quarters, while the hairs protrude from the socket about three-quarters or seven-eighths of an inch, round brushes in bamboo, and formed of white vegetable fibres, and about half an inch in diameter, plenty of water in a large bowl, Indian ink with its accompanying slab, and a few colours.

There is one old flower-painter in whom I ultimately become much interested, for he is full of innocent humour, and his ability as an artist seems as great as his fun. His colours are Indian ink, indigo, gamboge, crimson lake, and red earth. One of the other artists includes in his pigments a kind of dragon's-blood colour.

The artist who is to paint first comes forward, bows in Japanese fashion, and takes his place in front of the paper. He is an elderly gentleman, and after having looked thoughtfully at the paper for a minute or two, begins his work. Taking the porte-crayon, he touches the paper with the charcoal point at four or five places, so as just to leave a perceptible dot ; and then with his flat brush three inches broad, charged with Indian ink, makes on the paper, by an almost instantaneous dash, a large irregular mass of gray-black colour. With a smaller brush he now indicates, in close proximity to the gray mass, what appear to be a few feathers, next, at a little distance, the end of a pendent branch. Then, beginning at the top of the paper, he works the branch downwards till it is in the line of the end which was first drawn. Now an eye is drawn, then a bill, then come a few bits of colour, and we see completed in less than fifteen minutes, a cock and hen pecking in front of a branch of a tree, and, curiously, a great portion of the white body of the hen is rather indicated than drawn ; for as the body of the cock is gray (being the large mass of this colour which was first placed upon the paper), and as the white hen is seen against the black cock, the stopping of the black gives the form of a great portion of the hen's body. This interesting sketch was kindly presented to me by Mr. Sano.

The same artist next drew a small landscape ; but it is



scarcely necessary to say that Japanese landscapes lack the charm of their drawings of birds, fishes, insects, and flowers.

The old flower-painter, of whom I have before spoken, now took his place before the paper, and after looking at it as though he were picturing in his own mind a group of flowers already painted, made, like the former artist, two or three dots with the charcoal upon the paper, and filling a brush with some green pigment, began by forming here and there certain pæony leaves—one leaflet at a touch; but although from time to time he somewhat varied the colour in the brush, no two parts of the same leaflet differed in tint. With another brush he formed a red pæony flower,—shading each leaf by a dexterous application of a little water to the paper before the red was wholly absorbed.

Rolling up the paper at the bottom (a practice which all the artists adopt when they wish to work at the upper part of the sheet), he draws petals of an unfolded bud. Now with faint Indian ink he forms both flowers and buds of the magnolia, then he arranges pink petals into groups, resembling the flowers of the almond, and afterwards forms clusters of red masses, so that they ultimately appear as the peeping petals of red flower buds.

The masses of colour being thus carefully distributed with due regard to the laws of composition (a regard for the distribution of masses which may be commended to the authorities of the art schools at South Kensington), the stalks are so drawn that all the isolated parts are brought together with marvellous skill. Then the calyces are added, after which comes a little touching-up, as the formation of veins in a few leaves, the addition of certain bits of pure colour, and a spot of dark here and there. Judging from my knowledge of European artists, I doubt whether any one could produce a sketch of such excellence in anything like the time in which our Japanese artist produced his work; and although I myself am a trained draughtsman, and was as a young man engaged exclusively in studying plants and drawing flowers, I own my utter inability to produce so rapidly a sketch comparable with that which is now before us.

A young lady, who is, I understand, a flower-painter to the

Empress, now made a sketch of a little yellow flower allied to our winter aconite, but it appears as though just bought in the market, for the root is tied up in a bit of paper. This sketch took the lady about ten minutes to complete. She was followed by a young man, who made a drawing of a flying duck, which is "worked" much in the manner of the first sketch; but the skill with which the body, with its light, shade, and outline, was managed, was truly marvellous. A brush of considerable breadth was dipped in water and drawn between the fingers of the artist till nearly dry. It was then dipped in a thin wash of Indian ink, the central portion of the brush being bent outwards, so that the hairs of the brush assumed a crescent-like form. The convex or centre portion was now hastily dipped into dark Indian ink, and the brush was allowed to straighten itself. Two or three hairs were now separated from one side and dipped into dark ink, but these remained detached from the other part of the brush. By a dexterous movement the artist produced with one stroke the shaded body of the duck and an outline, the few separate hairs making the latter, while the shading resulted from the darker ink of the centre not having fully spread to the sides of the brush. A bill is now drawn, then feet, and then tail-feathers. An eye is added, then follows a neck, legs, and a few finishing touches when an admirable sketch of a flying duck is before us.

After two or three other drawings are made the middle-aged man, who painted the domestic fowls, kneels again in front of the baize, and begins what we all take to be a sea-piece, which he is drawing simply in Indian ink. Like the last artist, this gentleman produces a tint and an outline at the same time, and by the same method. After what we take to be waves are finished, and, when we expect the artist to place in the water fish, or upon it junks, he simply adds a few dots and dark touches, and signs his name. It is now held up to view, when, to our astonishment, the sketch is that of a train of rats, with one or two members of the party straying from the others. What we took to be waves prove only to be a background, against which the rounded backs of white rats appear;—the uncoloured paper forming the animals.

Fans were now offered to the various artists, and on these sketches were soon placed, the cretated character of the surface apparently in no way increasing the difficulty of the work.

Having had tea in an adjoining room, we returned to see an amusement in which Japanese artists often indulge. A sheet of paper being spread on the baize one of the company goes forward, and dipping a brush in Indian ink makes some simple device. In this case a cross was formed in the middle of the paper about two feet in height by fifteen inches in width. One of the artists called to the paper is told to draw a lady so that this cross shall become an unobtrusive portion of the drawing. With a few dexterous strokes, and in three brief minutes, he finished his work in a very admirable manner ; but the cross, being still slightly visible, somewhat marred a very excellent sketch. The entertainment had been intended, I learnt, for the whole evening. Unfortunately an engagement to dine with some friends forced me to tear myself away at 6.30, very greatly to my regret. While in Japan Mr. Sano contributed much to my enjoyment, but nothing that he did gave me the pleasure that I derived from the entertainment provided for me this afternoon.

## CHAPTER III.

Preparation for long journey—By water to Kobe—Entrance of the Mikado into Kobe—Awadji, Sanda, Arima, Nara—The Mikado's antiquities.

THE next two or three days were spent at Yokohama in arranging for a long journey into the interior, for through the kindness of the authorities I am permitted to travel in any part of Japan, and the ministers insist that during the rest of my stay I shall consider myself the guest of the nation.

Before starting on my journey I very imperfectly appreciated the favours and the inestimable advantages which I was to reap through the preparations so thoughtfully made for my enjoyment and well-being by the Japanese Government. Wherever I went, the manufacturers of the town in which I stayed were brought before me, and I had an opportunity of seeing whatever was interesting either in the way of architecture, antiquities, or manufactures.

Mr. Tanaka of the Tokio Museum arrived at my hotel with Mr. Ishida and Mr. Sakata, who are to form my escort during my future journeyings in the country, Ishida undertaking the finance and official duties, while Sakata acts as my guide and interpreter. I may here say that no two gentlemen could have acted with more kindness and consideration than they did throughout the whole of our travels, nor could any have more faithfully served the Government in whose service they were. Poor Ishida is now dead, or I should wish him every advancement possible; and as for Sakata, I can only hope that he will rise to a position that will reward his faithfulness.

At 2.30 we stepped into a boat at the custom-house pier, with Mr. James Saumarez, who will accompany us during the few first days of our travels. Bidding adieu to Mr. Tanaka, we pulled to the ship on which we have taken passage for Kobe. This steamer, which belongs to the Japanese Government, must be considered as fairly comfortable, and is built on the plan of an American river-boat. Saumarez and I have a cabin between us—he having the upper berth and I the lower ; but his differs from mine, in being some inches narrower and having an iron “stay” or rod passing through it in such a manner that its occupant must lie on his back with the rod passing upwards between his legs.

A finer evening than this never was. A few fleecy clouds, a glorious setting sun, a sky steeped in liquid hues, a cool breeze of most refreshing air, and Fujiyama rising in all its grandeur above the horizontal belt of cloud which so generally envelops its base, combine to give the waning day a charm quite inexpressible.

The glory fades and darkness comes on apace, but the moon, now two-thirds full, gives brightness to the deep azure of the clear night sky : thus one glory succeeds another, the second being but softer than the first. At 8.30 we are opposite a round undulating island, on which is an active volcano ; but the “burning mountain,” far from being awe-inspiring, is calculated to cast to the winds all preconceived notions of a volcano in eruption. From the centre of the highest portion of the island (which as we see it is by no means conical), and also from a small fissure in its side, issue a few flickering flames, such as might come from bonfires. Somewhat higher in the air is a cloud constantly changing its form, and which, fiery and glowing, hangs over the mountain. As the flames rise and fall, are extinguished or rekindled, so does the cloud brighten or darken. I see no lava coursing its way down precipitous declivities, and no vomiting forth of surging matter, nor is any noise audible. Nothing but the changing and fitful glare, such as one of our own blast furnaces produces, characterises this burning mountain ; in fact, the effect

is inferior to that produced by the blast furnaces of Lowmoor or of many in the Cleveland district.

The next morning was as lovely as the evening which preceded it. We ran near the land, and there Fujiyama, as immaculate as ever, rose above the horizontal stratum of cloud which appears to divide it in two. Below the cloud it has the colours of earth, but above it is pure as heaven. The air is cool, the sea is calm, and we go merrily on.

Mr. Saumarez introduces me to Mr. Samishima, a Japanese gentleman who speaks English well, and who is certainly possessed of great information, both respecting Japanese and European matters. We talked long of the commerce of Japan, and of how it can be extended to Europe; and I am struck with the soundness of his views concerning the future of his country.

In the year 1878, while in Paris as a juror at the International Exhibition, I received an invitation from the Japanese minister to dine with him at his residence in the Champs Elysées. I was most graciously received, and the face seemed familiar, but where I could have met my host I could not remember. When dinner was half over I recollected that my host was Mr. Samishima with whom I so long conversed while on my way from Yokohama to Kobe. From this time up to his death we were friends.

The day wore on, but its glory was not dimmed, and the Japanese coast near which we are running was as fine as some of the good Swiss scenery. We have here, as in the Alps, that strange effect which results only from an atmosphere untainted by smoke and unsullied by the vapours of factories: indeed, here we have rugged heights, deep ravines, hills piled upon hills, mountains upon mountains, and valleys sunk in valleys, with that play of light, shade, and shadow, which only such a country under a bright sun and cloudless sky can give. We pass no town during the day, but the hills are in some cases wooded to the very sea.

By 6.30 the next morning I was on deck, and found that we had anchored at 2 A.M. in Kobe harbour, which is three hundred and sixty nautical miles from Yokohama. Cannon were firing,

rockets of various kinds were ploughing their way through the air, and the ships and junks were gay with fluttering flags.

All this excitement is due to the fact that the royal yacht is hourly expected, for the Mikado is coming to open the new railway connecting Kobe with Kioto. I watch these fireworks, which are being discharged in rapid succession, with somewhat special interest, as I take them to be the day fireworks of which we have heard in Europe, and the smoke which they generate certainly assumes strange and fantastic forms. To my disappointment I learn that these are not day fireworks, and that the Japanese like letting off ordinary fireworks in sunshine. If this is so, it is almost worth letting some off in sunshine, for the circles of smoke formed by some, like the rings of phosphuretted hydrogen that we used to make when playing with chemistry as boys, are very curious.

At the custom-house the officers searched the luggage of Mr. Saumarez and Mr. Sakata, but passed mine. The practice of searching baggage when brought from one port to another of the same country seems strange, and is certainly attended with much inconvenience to passengers.

A foreigner travelling in Japan must have a passport ; and if the journey is to be anything more than a brief excursion to some town not distant from a treaty port (where alone a foreigner can reside) he must apply to the minister of the country to which he belongs for the necessary permission. But the difficulty in the way of a stranger visiting the country is this. In order to get the passport he must not only name the provinces through which he wishes to pass but the towns that he wishes to visit, and the roads along which he intends to travel. He must also state the purpose of his visit ; and when in the interior he can neither make valid agreements with natives, nor purchase goods without danger of their being confiscated. These restrictions render it extremely difficult for the stranger to travel in Japan. There is neither a Murray nor a Baedeker to tell him what to see, and he can form no idea as to the roads along which he must travel ; hence, if he is resolved on seeing the country he must be content

to wait at the treaty ports till he can gather from European residents sufficient information to enable him to arrange a route : after this the getting of the necessary permission is only a matter of time.

The restrictions respecting the validity of agreements and the purchasing of goods are met by Europeans who travel in the interior by taking with them a confidential Japanese servant (called a *banto*) who makes purchases and enters into contracts on behalf of the European. Hence, these restrictions are practically of little inconvenience ; yet as all restrictions limit trade, the necessity of even a passport is to be regretted.

Sir Harry Parkes has kindly procured for me a passport worded as broadly as possible, being unaware that the Japanese Government have made every provision for my journey. The ministers have, in fact, granted me permission to travel wherever I please, and to see whatever I choose to inspect ; and to few, if to any other than myself, has such a privilege been granted.

The Mikado's yacht now arrives ; and we hear that in a short time the Mikado, with his ministers, will proceed in state to the railway station ; so we seek a place from which we can view the procession. The roads are densely lined with people eager to see his Majesty, and the central space is kept clear by lines of soldiers placed some six feet apart. It seems strange that wherever there is an upstairs window, or an elevated position, it is unoccupied ; but I learn that no man in Japan may look down upon the Mikado ; and when the Duke of Edinburgh visited Japan, orders were given that this same respect should be shown to him.

All is still, for the Mikado is approaching. The conduct of the Japanese is in the highest degree respectful ; but immediately in front of the procession, and only about fifty yards in advance, I see walking in the most slouching manner two filthily dressed, black-faced European workmen (I am afraid English) with torn caps hanging half over their eyes, short pipes in their mouths, and hands in their pockets. The sight is, I confess, both irritating and disgusting. While such strange conduct might,



in a case like this, be accounted for by ignorance, another act of disrespect which I witnessed cannot be thus excused. Beside me stood an English missionary with the broad-brimmed felt hat worn by many of our clergy. On the arrival of the Mikado, all who had hats (for many of the male natives do not wear head coverings) uncovered and lowered their heads. But this one Christian gentleman availed himself of a step in order to make himself conspicuous, and nodding his head defiantly, declared audibly that he would not acknowledge the heathen sovereign. I had always thought that royalty was entitled to respect wherever it was seen, and I can scarcely think that a Japanese standing in our streets while royalty was passing, and loudly averring that he would not uncover to a Christian infidel, would get off without reproof, for even our street roughs, ill-behaved as they are, would feel that such an insult to royalty should not pass unnoticed, and even the cloth would have failed to protect from mob law. Although not of combative disposition, I felt almost irresistibly impelled to give that missionary a lesson in manners such as he would not easily forget, and it was only my respect for the feelings of my honourable friend from the Legation that prevented my so doing; but if looks could do anything in the way of revealing my contempt for this individual who was living on the charity of those who desired that he should teach the doctrines of kindness and love, I must have smitten him to the very quick, for a look of most sincere contempt must have characterised my features when he thus publicly insulted a sovereign of high gentlemanly feelings and the greatest refinement. If this is the manner in which our missionaries act (and I confess that while in Japan I saw little to admire, but much to condemn, in those with whom I came in contact), we cannot wonder at illiterate men who may be stokers on board a vessel, or ill-bred workmen, acting in defiance of right and order.

If it should be asked why such things are permitted, the answer is that in the open ports of Japan foreigners have what is termed an extra territorial right; that is, the Japanese have opened a certain number of ports called treaty ports in which

foreigners may reside without being placed under the jurisdiction of Japanese law. In other words, the foreigner while resident here is subject to the courts of his own country ; thus in the eyes of Japanese law he can do no wrong, and the judge by whom he must be tried is his own consul.

The English complain bitterly that they cannot travel in Japan without a passport, while the Japanese can travel through any part of England without restriction. I cannot help thinking that restrictions to travel injure the commerce of any country ; yet when speaking to the Japanese ministers respecting the opening up of the country, they invariably said that with the class of settlers which are now in the treaty ports, it is impossible for them to allow travelling in the interior unless the Europeans give up their claim to extra territorial rights, and this seems but reasonable. If a Japanese comes to England he is free to travel wherever he pleases, but he is at all times amenable to English law ; and I am sure that no man who conducts himself rightly, and has that regard for the feelings of others which all gentlemen should have, need fear any molestation from the Japanese.

The procession having passed, Mr. Ishida went to the government house to report our arrival, Mr. Saumarez to the English consulate to try and get a steam yacht for an excursion which we wished to make the next day, while Mr. Sakata and I walked up the mountains to see two waterfalls, the one called the Male Fall and the other the Female.

Kobe is one of the treaty ports, and it occupies a strip of ground lying between a range of rocky hills and the sea, the hills and the sea-shore being parallel. It was intended that Hiogo should be open to foreigners ; but as this town was not suited to the purposes of foreign commerce, Europeans were allowed to erect their town at the north side of a river which now separates Hiogo from Kobe, Kobe being the new town, and Hiogo the old.

The same thing occurred at Yokohama, where a new town has been built at the distance of about two miles from the port originally opened up, the new town being Yokohama, the old town Canagawa.

From the hills which we ascended we had a charming view of Kobe, of the bay, of the island of Awaji, and of the ocean beyond ; and it was to the island which lay yonder before us that we intended to make our excursion on the morrow.

In the evening Kobe is beautifully illuminated in honour of the Mikado's visit. As the illuminations consist wholly of coloured lanterns, which are here used with great lavishness, the effect is very charming ; and the interest is heightened by the myriads, as it appears to me, of moving lights which are intermingling and bobbing, now being visible, and now eclipsed. These are the lanterns carried by the sight-seers, for every one in Japan carries a lantern after dark. The effect is also heightened by the fact that it is a feast day at one of the great temples at Kobe. Here we have blazing beacons, the burning of incense, the sound of music, the throngs of worshippers, and much that is calculated to add interest to the scene. The whole is a brilliant manifestation of life, worship, and enjoyment, such as could, probably, be seen in no other country.

The steam launch having been secured, we are astir at 6.15 A.M. It is just dawn, and the morning is fine. The island for which we are bound is that of Awaji in the Hiogo Ken (province), and we propose landing at the chief town, Sumoto, which, we are told, we shall reach in three hours. It may be interesting to know that before the revolution of 1868 Awaji belonged to the Daimiô of Owa, and that the ex-Daimiô was educated at Oxford, and now resides in London. On the island there are 30,000 houses, distributed in five towns and numerous villages, of which 3000 belong to Sumoto.

While cotton stuffs and cotton thread are made on the island, and this small tract of land can boast a "fluted" variety of the bamboo which is found in no other district, our chief purpose was to see certain potteries, of which I shall speak more in detail hereafter.

It was 7.30 before we were fairly under way, and we had not gone far when the sky became overcast and the clouds lowering, yet we steamed on grandly. The scenery was very beautiful ;

indeed, as seen from the sea the island to which we were steering looked almost Alpine in its grandeur.

At half-past ten we had not yet even reached the island, and the town of Sumoto is situated almost at its other side. At twelve we had luncheon (tiffin), so as to economise time, for we were told that after we reached Sumoto we should have seven English miles to traverse in jinrikishas before we could get to the potteries. It was one o'clock when we reached Sumoto.

The landing of Columbus could not have produced a greater effect upon the Americans than our landing in Sumoto did upon these islanders. Adults and children, rich and poor, young and old, flocked to see the strange creatures that had come to their shores. They followed us as the street arabs follow a Punch and Judy show in London. Even in Tokio a foreigner cannot make a purchase without a score or more persons gathering around him; but here the whole town was astir with excitement.

Entering the post-office, we waited for jinrikishas; and I may here remark that in all Japanese towns where there is no hotel, the post-office has to make such arrangements as it can for the accommodation of visitors. We soon started on the inland portion of our journey; but the potteries, which we were told were seven miles distant from Sumoto, proved to be fifteen. The road, at first very good, lies along a valley where paddy fields abound. The hillsides are wooded with camellias and dwarf bamboos, but ferns are abundant in the shady spots, and here and there we see a palm-tree.

At a tea-house about eight miles along the road the men stopped for five minutes to rest, and tea was politely offered to us, as is usual, by the mistress of the house. The road became more difficult as we advanced. What was formerly a mere track is now being made into a good highway. Some of the new bridges are in every sense excellent, and they are sufficiently broad for a cart to cross them, while the old bridges were little, if any, broader than a jinrikisha. We now leave the main road for a path through the rice-fields, and as the path is raised above the muddy fields, there is some excitement in the thought that if one wheel

of the jinrikisha should slip over the edge of the narrow bank the occupant would find himself in the sludge below. Nor are matters rendered pleasanter by the fact that the bank is cut by frequent streams spanned by two planks or two narrow stones. While crossing one of these primitive bridges one wheel of my carriage slipped from the plank on which it rested, but owing to the promptness of one of my men I was saved a ducking in slush. Hence some of the party, who fear that they may be less fortunate than I was, are lifted over these bridges, carriage and all.

An accident now happened which might have been serious, but turned out only laughable. The man in the shafts let go his hold, and my weight being behind the wheels, the jinrikisha was overbalanced backwards. In a moment my head was on the ground. But the vehicle was soon righted, and we went on our way. After many windings we reach the village of Igano, where are two potteries, one of which was founded by Kashiū Mimpé, about fifty years since, for imitating the Dutch ware of Delft. The present potteries belong, one to the son of the founder, whose real name is Mimpé, but who has assumed the trade name of Rikita, instead of the second Mimpé; the other belongs to Sanpé, the nephew of the first Awadji potter.

During our inspection of the potteries heavy rain begins to fall, and it is now six o'clock P.M. We make a hearty meal on boiled eggs. I should have been glad, I confess, to have a little salt and a slice or two of bread-and-butter in addition; but bread is unknown in Japan, save at the open ports and at one or two of the large towns which have become partly Europeanised; and those who think that rice is the common food of the people know little of Japan, for to the poor, as I have already said, rice is an almost unknown luxury.

When we re-entered our jinrikishas, the hoods, which open and close like the hoods of our Victorias, were spread, and over our laps a sheet of oiled paper was placed as an apron. It must not be supposed that the Japanese oiled paper bears any close resemblance to a sheet of English paper which has been greased.

for it has pliability, toughness, and a fibrous character, while the oil which has been applied to it renders it waterproof without making it greasy. The hood of the carriage was too low for my European proportions, and I had to sit in a cramped posture. This, with the cutting wind and the driving rain, rendered the journey back to Sumoto anything but pleasant. Occasionally, also, during our homeward ride we had to cross the beds of large mountain streams which, containing but little water, are rich in boulder stones. These river-beds usually lie at a level considerably below that of the country which they traverse ; and, although impassable during the rainy season, are readily crossed at other times by the aid of stepping-stones. The sensation produced by the crossing of one of these streams is remarkable, especially when this takes place in the darkness of the night. Descending the defile, the jinrikisha acquires an impetus increasing each moment. Hence the men who draw it are rather servants of the vehicle than its guides and masters. The boulder stones also cause an unpleasant jolting, and further difficulties are presented by the stony bottom and the upward ascent.

With the view of turning to good use the speed gained during the descent, the man in the shafts, who is now alone in charge of the vehicle, lets the carriage rush down at an alarming pace, aiming at the stepping-stones, across which he runs, while the wheels of the vehicle are on either side of these stones trundling across the bed of the stream,—and the occupant expecting every moment to find the bottom of the carriage torn off by coming in contact with a stepping-stone, or to have a ducking in the water through the upsetting of the vehicle.

Our journey is, however, completed by 9.30 ; but as it is too late to steam to Kobe, we take supper on the launch and return to the post-office to sleep.

We are now shown to our rooms. However large a party may be, one room is considered sufficient in Japan if it will but contain enough beds on its floor ; but in this case Saumarez and I are favoured with a room to ourselves, while the Japanese occupy another apartment. Our beds are now prepared, that is,

are spread upon the floor, and each of these consists of what we might term three wadded coverlets, each about six feet long, three feet wide, and one inch thick. These are covered with a blue-and-white figured cotton fabric. In consideration of the wants of us foreigners, a fourth coverlet, rolled into the form of a pillow, is produced. On a stand beside the bed was placed a lamp, the feeble light of which proceeds from a small rush wick hanging over the side of a saucer suspended in its centre. This, with the beds, forms the whole furniture of the room.

It is now 10.30, but although a bed is before me I do not exactly know what to do with it. Which is the bed and which is the covering? Am I to lie on the floor and have the three coverlets over me? Am I to lie on one and have two as covering? Or am I to make of the three a soft bed and spend the night uncovered? After puzzling over my difficulty until I seem threatened with abject despondency, I call for my friend Sakata, who only partially removed it by telling me to do exactly as I pleased. Hence I determine, as the night is cold and the air damp, that one should be my bed and two my covering. But when in bed a new trouble arises, for my bed and my bed-clothes are each of the same narrow dimensions, hence it is impossible to tuck in the coverings; and owing to their want of pliability, I only succeed in keeping the cold wind, which howls through our room, from one side of my body at a time. Still, in spite of all my difficulties, I slept soundly till dawn. On rising we were somewhat stiff and sore, but this is due in part to our cramped posture during our journey yesterday, and only in part to the hardness of our beds.

The shutters being removed from the outside of the balcony, we open the paper slides which form the front boundary-wall or window surface (for it is both) of our room. Here is a lovely little garden, over the end of which hangs a tree laden with golden oranges. On the balcony stand two chairs, each bearing a copper pan of about twelve inches in diameter and three inches in depth, with water for us to wash in. Soap is unknown in Japan. Pendent from the eaves of the roof hangs a little

trapeze-like contrivance, which is the towel horse ; but this is empty, for travellers in Japan carry their own towels. A further supply of water is at hand in a large wooden bucket which rests on a huge boulder-stone and has a ladle lying across it.

During our ramble after breakfast we soon come upon a shop which concerns itself only with the making and selling of *Jos houses*. Some of these are very interesting, and they are all marvellously cheap. Then we see a cabinet manufactory, where such cabinets as the Japanese must use for the storing of their clothes (although I never saw one in any house) are made. These are so absurdly cheap that I purchased one, which I afterwards sent to England. The cabinet cost thirty shillings, but the freight home was seven pounds ; hence what was absurdly cheap where I bought it was absurdly dear when it reached its destination.

Having made the circuit of the town, we returned to our boat. The sun was bright and the sky clear, but there was a strong cold breeze blowing. We were soon under way. After tiffin I went on deck, and surely scenery never was more lovely than that which I now beheld. There was that soft drawing of mountains on the skies which I have never before seen out of Switzerland, and the scene was in truth enchanting.

It must not be supposed that our steam launch is a model vessel. A little paint would have improved its appearance ; and although it has a deck with a cabin beneath it, a stoke-hole, and engine-room, the deck has neither seats upon it nor rail around it, and the cabin is reached by—well—any means you please, for while there is a hole in the deck which, when you are in the cabin, appears as a hole in its ceiling, there are no steps by which either the descent or the ascent can be made ; therefore getting from the deck to the cabin, or from the cabin to the deck, involves the performance of acrobatic feats of no mean order.

The stoke-hole and engine-room are reached from the cabin through an aperture about two feet by thirteen inches. Windows, which should have consisted of twenty-four panes of glass ranged in longitudinal series, form the sides of the cabin ; but of the twelve panes at one side six are broken, five being entirely out.



This, although of little importance had the craft been nestling on the bosom of a small inland lake or of some placid river, might prove serious if caught by breakers from the broad Pacific, and it is on the fringe of this ocean that we float.

Lounging on the deck of our little craft, I am lost in admiration of the lovely scenery as it is lit by the last rays of the setting sun ; but while comparing our speed with that of a Japanese junk which we overtake and pass, I am suddenly aroused from my reverie by a sharp and curious noise, which is followed by clouds of ashes and steam rising from the entrance of the cabin. Our boat stops, for the boiler has burst in the fire-chamber, and has put out the fire. We are now perfectly helpless, for we have no sailing gear of any kind. Perceiving that the night is coming on, and that without assistance we must speedily drift out into the mighty ocean, my first impulse is to hail the junk, which I at once proceed to do. Saumarez instinctively drops into the cabin to ascertain the nature of our food supply, and finds to his sorrow but a little tinned meat, half a pot of jam, and one or two biscuits. So all come on deck, one having brought with him the table-cloth, which is immediately held out as a signal of distress, while a very chorus of shouts asks aid of the junk near by. The junk approaches, it gets nearer, it is now only fifty yards off, but it passes by. Our Japanese friends shout that we will give much money for their help. This produces its effect. A rope is thrown, and we are made fast to the junk and towed towards the shore, but only at snail's pace, for the tide is against us. In a short time, however, boats come from the land to our aid, and stepping into one we leave the steamer in charge of our sailors, and row straight for the lights of Kobe.

Our next excursion is to the Sanda pottery district, where much Celadon ware is made ; a district which I have a special desire to visit. Little is yet known of the Celadon wares of Japan, and I am informed no European has yet visited the potteries at which it is made. The Awadji potteries which we visited two days since have only been visited by two Europeans—one Englishman and one Frenchman, but these were in the employ of

the Japanese Government, and, I understand, were not interested in potter's wares.

*January 31.*—At 6.30 we are astir ; at 7 we breakfast ; and by 7.30 we have started in our jinrikishas for Shidewara in Sanda, the centre of the district in which the Celadon ware is made. As our journey, we are told, will take about four and a half hours we calculate that we have an easy day's work before us, and that night may be spent in our comfortable beds at Kobe. Three men are engaged for each jinrikisha so as to economise time. For several miles the road ascends and borders a rocky defile, in the bottom of which flows a mountain stream. The highest point being gained, the road becomes easier, winding through paddy fields and amidst well-cultivated gardens. Our men gallop on, but while to me the work of pulling us up the long incline stretching from Kobe to the summit of the pass seemed killing, the men are yet as jocular as schoolboys, and with occasional cheery shouts run as though they could never tire. Still, instead of being at Shidewara at twelve o'clock, we do not reach it till four.

I have brought with me to Japan a pedometer with the view of roughly ascertaining the distance traversed in out-of-the-way districts and on unknown tracks ; but, while the pedometer at best is but an imperfect instrument, in this particular case it proved utterly useless, for the long strides which these coolies took during their wild and joyous gallops were most unfairly recorded as so many ordinary steps, and how many of their giant strides make a mile I have no idea. The coolie in the shafts carried the instrument, which, at the end of the day, recorded twenty-three miles as the distance run ; but I am persuaded that the long and toilsome pull up the hill, at the commencement of the journey, being considered, the speed did not average less than five miles an hour.

At Shidewara we learnt that here, and in villages near by, there are five potteries, but that all are small, and this we find to be the case. A master with his son, or with one or two assistants, appears to be the entire staff of each pottery in the district. In Shidewara itself there are two potteries, one of which

is exceedingly small ; but as neither make wares of any special interest, we leave the town by a track or road, which leads to a little plateau of moorland on the ridge of a high mountainous hill. We have traversed about a mile and a half of ascending road when we come to three small potteries near to each other, and owned by various branches of one family. Here we rest for a time and inspect the wares of the different manufacturers till the shades of evening seem to hint that it is time for us to return ; but we cannot go without spending a few minutes in viewing the scenery around us, which is grand and lovely. On the hills and in the dells we get shadows mingling with vapours on the one side, and tips of roseate light on the other, while across yonder valley rises a vast range of hills whose summits are now of glowing pink as the last rays of the setting sun fall on their snow-clad peaks.

Our coolies start on the return journey with an elasticity of tread, induced by the bracing air and a descending road, which soon brings us to Shidewara, where we find Mr. Ishida (who had stayed behind somewhere on the way), and, to our surprise, the Government official who had accompanied us to Awadji seated in a tea-house. Where the Government official can have sprung from we cannot imagine, for this is his first appearance amongst us to-day. Ishida informs us that he has secured us rooms, and that we must stay the night here ; but Saumarez and I insist on returning, as we are in no way prepared for a two-days' journey, and have not even a tooth-brush with us. To his pleading that the dangers of the way are considerable, owing to the bad roads and worse bridges, we turn a deaf ear ; but when we are told that the chief seat of the basket manufacture is near, that the village in which this industry is carried on is very beautiful, and that by staying the night we can thus see another industry and a beautiful town, we consent to remain and to get through the night as best we can.

In front of every Japanese hotel, and running along the greater portion of its length, there is a sort of seat which, although little more than a continuation of the floor beyond the sliding

partitions, constitutes the windows. This is the travellers' resting-place, and here we have our dinner ; but to our sorrow most of the sandwiches which we brought with us have disappeared, and what remains in the way of provisions is chiefly a pot of jam. It was a happy thought of Saumarez putting that jam in the basket, for in most places rice can be got for money ; and although poor rice boiled in water scarcely forms of itself a satisfactory meal, jam gives it a relish and makes it, at least, palatable. Very often, since the time of which I now write, have I made my meal of only jam and rice, and I soon came to the solemn conclusion that a monument ought to be erected to Saumarez for first introducing the practice of carrying English jam when on an inland journey in Japan.

The wayside hostelry or rural inn of Japan is an interesting place,—its scrupulously clean rooms separated only by sliding paper partitions, its raised dais, on which the Mikado would sit should he ever select this apartment as his resting-place, the side-opening in the partition which rails off this domestic throne, through which his food would be passed, the balcony outside the room with the garden beyond, and the bath, which is supplied for the refreshment of the traveller, give to it a character which cannot fail to please.

While the bath is enclosed in a separate room, which generally lies within sight of the central courtyard or garden, it is not deemed necessary that the process of unrobing may be conducted within its damp precincts ; and here, where all the rooms of the hotel look upon the one enclosure, and where the front window-slides are removed from all the rooms, I observe two of the newly-arrived occupants of opposite rooms undress, and wearing literally nothing but a smile, walk along the balconies in front of the public rooms in the most unconcerned manner possible ; and, neither noticing, nor being noticed, save by the rude foreigner, proceed towards the bath-room, which the one enters while the other remains on the balcony awaiting his turn. There is certainly a charming simplicity about the Japanese, who, in whatever condition he may be, has never yet discovered that under any

circumstances he is naked. I have seen at many hotels what to me were indeed strange sights; but I never saw a lustful look, a lewd act, nor any manifestation of ill-advised emotion, inconceivable as this may seem to the European mind.

After our meal, which consisted chiefly of rice and jam, we ask for a little brandy or wine, as we thereby hope to encourage digestion; but nothing of the kind is known or has ever been heard of in this happy and innocent town. Being ready for bed, we clap our hands, for this is the manner in which the servant is called in Japan. Our beds are soon ready: there are three coverlets for Saumarez and three for me, and to each is allotted a bag of rice husks for a pillow.

We are scarcely in bed when a girl enters our room to take a pillow out of a cupboard. In these strange houses where three walls of most rooms consist of movable slides, any of which can readily be pushed aside, one is always being surprised by the entrance of a servant in some unexpected corner, for there is nothing in a Japanese room that represents a door or fixed place of entrance,—people enter at the point most convenient to themselves.

At seven in the morning we rise, and on pushing aside the window-slides in front of us, we perceive that a small tub has been placed on the open balcony in front of our room, while beside this stands a large vessel of water covered with ice, and that a towel hangs from the pendent towel-horse, for Mr. Sakata has explained that we were unprepared for spending the night from home. Hot water is, however, brought us in a little "piggin," and this added to the cold serves at least to melt the ice. We shiver and wash, and dry ourselves as well as we can, for a Japanese towel, it should be remembered, is only a piece of thin blue-and-white cotton cloth, of three feet in length and ten inches in width, and while it is often adorned with an interesting pattern, it appears to the European but imperfectly to serve the purpose for which it is intended. Our beds are cleared away, and on two little trays about twelve inches square and supported on legs three inches in height, is borne our breakfast, which

consists of tea, boiled eggs, and rice—the rice being brought in a large covered wooden vessel which stands in the centre of the room. The tea is in a teapot supported by a small iron frame over a hibachi (fire-holder) resting on the floor. The eggs are in saucers, one of which occupies a corner of each of our trays, and with the exception of an empty bowl, a diminutive cup, and a pair of new chop-sticks which fill three other corners of our trays, they constitute the entire settings of our breakfast-table.

A serving girl, who brings with her a small tray, now kneels behind the rice-box, and holds out first to one and then to the other her tray in order that we may place on it our rice bowls, one at a time. Putting into the bowl a portion of rice by the aid of a flat wooden spoon, she hands it to its owner, her duty being solely to serve the rice and to bring anything that a guest may choose to ask for. We have some little difficulty in eating our breakfast, for as there are neither egg-cups nor egg-spoons, we have to adopt a method of peeling and sucking and sucking and peeling, which would scarcely seem elegant if practised at a European breakfast-table; and worse than all we can get no salt.

At eight o'clock we are on our road for Arima, the seat of the basket-manufactures, and a lovely road we travel. In two hours we are there, for the morning, which is fine and clear, is still cold and frosty, hence our coolies run well. Arima is a most charming little Swiss-like village, beautifully situated on the side of a valley where a mountain torrent dances between moss-grown stones and winds beneath the shade of rich overhanging foliage. The chief street of the town consists almost wholly of basket-manufactories, bathing establishments, and charming tea-houses, and here nearly all the buildings are two storeys in height.

A more beautiful town than this I never saw, for the picturesque of its buildings and their delightful cleanliness would of themselves render it most attractive; but here we find lovely scenery, lichen-covered crags, moss-grown stones, plumose ferns, and withal, the rushing of impetuous waters. So beautiful indeed is Arima, that I feel as if weeks could be spent here most

happily. After tiffin, which was prepared for us in an upstairs room in the chief tea-house of the town, we walked through the principal street and inspected the basket manufactories, the chief industry of the town. Here we see baskets of many kinds and shapes, baskets both large and small, baskets so dainty that the highest lady in any land might give to them a place in her boudoir, be it ever so carefully arranged. Indeed, such a collection of beautiful baskets I never before met with. Japan is truly the land of baskets, and while up to the time of my visit much Arima work had found its way into the London market, it was all of a common kind; and it was not until I pointed out to the Japanese that the better kinds would find a ready sale in Europe that they were introduced into England.

We now discover that Arima is one of the most fashionable watering-places of Japan, and that it possesses mineral springs which have a great reputation for healing virtues. We look into one of the bath-houses, which in some respects resembles those of Lukerbad in Switzerland, and here ladies are enjoying themselves; but they have dispensed with even the most simple apology for a bathing costume. They are, however, in no way abashed by our presence, and, to our astonishment step from the water to hear particulars of the foreign visitors.

Much beautiful straw-work is offered for sale in Arima. It is indeed so abundant that I thought it must be manufactured here. But I find that it is all brought from Tagima, a town about fifty miles distant and directly inland.

Time is now so far spent that we are obliged, though most reluctantly, to take once more to our jinrikishas, and start on our return journey. On the road Sakata stopped our little caravan to explain that at the village which we are approaching much paper of an inferior character is made from waste paper which has been collected and reduced to pulp by little more than wetting. Upon entering the village we stopped at the door of a paper-mill; but, on being told that there are two much larger manufactories farther down the village, we went to one of these. Our first feeling was of wonder. If this be one of the largest

mills what must the smaller mills be, for here there is but one vat, and that no larger than an ordinary washing-tub, one hand frame on which the paper is made, and this only seventeen inches by twelve, while one woman and a boy constitute the entire staff of the establishment.

The frame which the woman uses has a margin of wood, while a layer of bamboo threads, about as thick as the shank of an ordinary pin covered by a sheet of hard silk forms its centre. She was sitting in front of the vat, which was in shape a parallelogram, and in size three feet six by two, and about eighteen inches deep; in this vat was the pulp. She had the "frame" in her hand, and by her side rested a pile of the wet paper which had just been formed; but here the sheets were not separated the one from the other by layers of flannel or any other substance. Having stirred the contents of the vat, she simply dipped her frame into the pulp and collected as much as she wanted, and by a dexterous movement caused it to flow evenly over the silk surface of the frame. Allowing it to rest for a few minutes to give time for the water to drain off, she added this newly-formed sheet to the wet pile by inverting the frame, and thus went on making sheet after sheet. On the top of the pile of wet sheets of paper a board is placed, and upon this a few large stones, thus a quantity of water is squeezed out from the newly-formed sheets; and the fact that these sheets do not adhere the one to the other must be explained by the great length of the fibre of Japanese paper, and by the small amount of size used in its manufacture. The size employed at this paper manufactory is obtained from a small conical root of which I do not know the name, the glutinous matter being extracted by soaking it for a long time in water and then crushing it.

A sufficient quantity of water having been pressed from the paper, the boy brings a plank of wood of about six feet in length and thirteen or fourteen inches in width, and then removes the boulder stones and the board from the newly-formed paper, then separating from the heap the uppermost sheet, and placing this on the plank, he presses it down so that it adheres by its own



moisture to the board on which it is placed, and so with a second and a third sheet. This done, he takes the board to the open air and leans it in a slanting direction against the side of the house. The same operation is continued with other sheets and other planks till the whole pile is disposed of in this primitive manner. In one instance I observed that an economy of space was secured by six sheets of paper being stuck to the one board—three on each side ; but this board was outside one of the small factories of the village, which probably was not so rich in boards. The paper being dry, it is simply peeled from the boards and arranged in bundles for the market.

We now go on our way, and our men run well. At Kobe after a twenty-five miles' gallop they scamper like wild Arabs through the town, and appear as fresh as if they were beginning instead of ending their hard day's work.

Our next journey, one of the most interesting during the whole of my travels in Japan, was to the ancient city of Nara, where Mr. Okubo invited me to inspect the rare collection of antiquities which have been the private property of the reigning Mikado from very remote ages. The time at which it was formed is unknown, but the collection probably consists of presents given to the early emperors by the envoys of foreign potentates, and of the spoils of war. Whatever its origin may be this is certain, that an inventory of the main body of the collection was made more than a thousand years since, and that this inventory still exists with the objects therein catalogued.

We are astir early, for we have our packing to do as we are now saying adieu for the time to Kobe. At ten o'clock we leave by train for Osaka—an hour's run by rail on the way to Kioto ; from Osaka we start in jinrikishas for Nara, which is distant about thirty-three and a half English miles. With but one stoppage of half an hour on the road our men end the journey better than they began it. To me it is perfectly astounding how the coolies go through the toil which they do, and that without apparently suffering fatigue. Fancy a heavy man (for my weight was then about thirteen stones), wrapped in thick coats and a fur rug, seated

in a carriage with a large heavy dressing-bag at his feet, being dragged by the same men for thirty-three and a half miles at the rate of between five and six miles an hour, with only stopping thirty minutes on the journey. The exertion necessary for the fulfilment of this task seems almost superhuman; yet these feats of endurance I shall often have to record during my inland journey.

As though our poor coolies had not dragged us far enough already, we were told at Nara that the hotel was half a mile on the other side of the town. Having reached and inspected it, Sakata said that it was not a good hotel, and that we must go back to another in the town: but my suspicion is that the proprietor has an aversion to foreigners, for in some of the out-of-the-way districts where a foreigner has never or rarely been seen the Japanese seem afraid of him, and Sakata tells me that he was himself brought up to believe that if ever a foreigner caught a Japanese alone he killed and ate him; and when he was nine years of age he had the firmest conviction that the belief was literally borne out by fact.

While the hotel for which we have to make is a good mile distant, the coolies start as cheerfully as if they were just fresh from a long rest, and with shouts and laughter bolt off at a most astonishing speed. No people that I know of are as happy as the Japanese. A Japanese is said never to be angry, and I must say that although we were often in most trying positions I never once saw Ishida out of temper, and I never but once saw Sakata in the smallest degree angry, while I was frequently almost boiling with rage. The Japanese are said never to scold, and never to punish their children, yet I never in my life before saw such happy, well-behaved children,—so cheerful, so merry. I never heard a child cry save when actually in bodily pain. Is it because the Japanese are almost exclusively a herbivorous race while we are largely carnivorous?

By six o'clock, having run thirty-four and a half miles in six and a half hours, we are housed in our hotel, a grandly quaint building of true Japanese character, with the kitchen open to the street, and a courtyard with a gallery all round. We dine in true

Japanese fashion on the floor, and my writing has to be done in a recumbent position, for we have neither chairs nor table.

Nara is one of the oldest and most interesting cities of the country. Prior to the revolution of 1868 Kioto (the word Kioto, as I have already said, means southern capital, while the word Tokio signifies northern capital) was for seven hundred years the capital of Japan, and for some years previous to this the Mikado's residence was at Nara, which was then the imperial city. It was during the imperial residence in Nara that the rare collection of antiquities was placed in the house where it still remains, and to inspect this collection Mr. Okubo has kindly obtained for me the Mikado's permission; but many objects were old even when brought together in Nara. The city also is full of antiquities of the greatest interest.

Up to two years since these antiquities of the Mikado had never been seen save by those immediately connected with the emperor himself; but then for a short time some of the treasures were exposed, in what we might call the cloisters of one of the great temples of the town, in glass cases protected from the people by railings. This is the first time, I believe, on which they have been shown to any foreigner, save when they were open to public exhibition two years since, and it is certainly the only occasion on which the foreigner has been allowed minutely to inspect and to handle them. Hearing that they were to be opened, Mr. Saumarez asked that he might see them at the same time with me, and this permission was readily granted.

The following interesting extracts are from the *Japan Weekly Mail* of June 12, 1875:—

“Nara was the residence of the Mikados from A.D. 708 until 782. Shortly after this date the Imperial residence was fixed at Kioto, where it has since remained down to our own times. Seven sovereigns reigned at Nara, of whom four were females. Their rule, with some slight interruptions, was a prosperous and glorious one, distinguished by the cultivation of the arts, literature, and religion. In the reign of the empress Gemmio Tenno (A.D. 708 to 715) copper was first found in Japan. In 718, under the succeeding empress, a collection of laws in ten volumes was made, and shortly after a history of Japan in fifty volumes was composed. The Mikado, Shomu Tenno (A.D. 724 to 748), had

relations with China, and in his eighth year two Buddhist priests arrived, one from Southern India, the other from Siam. About the fifteenth year of his reign a colossal Buddha of copper, overlaid with gold, was erected at Sitaraki, in the province of Omi, by the exertions of a priest named Kioghi, who went over the whole kingdom to collect funds for the purpose. In the year 745 this statue was transported to Nara, and is the famous Dai-butz which exists there to this day. It is fifty-three feet high, being three feet higher than the better known Dai-butz at Kamakura. It was cast in a number of pieces, and it will thus be readily understood how such a colossus could be transported from Sitaraki to Nara. Little of the gilding anywhere is now visible. The head also of the statue is of more modern date than the rest. The temple having been burned in the sixteenth century, the head was so injured that it required to be replaced; the present face is much coarser and sterner than that of the Kamakura Dai-butz, and is probably not an exact reproduction of the original. The religion of Buddha was making great progress in Japan at this time. In 746 died a priest named Gen-bo, who had brought from China five thousand volumes of Buddhist books, and many images. In 749 an imperial edict was issued forbidding the slaughter of any animals in Japan. Poetry was also much cultivated, and some compositions of this class are still extant.

“The last sovereign of the seven, Kwonin Tenno, died in 782, and his successor determined to remove the seat of Government to another place. It was some time before a locality was permanently fixed upon, and the transfer to Kioto did not take place till 794. Previously to the Court quitting Nara an immense wooden magazine had been erected there, in which the imperial furniture and property of all kinds was disposed.

“This building exists to this day in complete integrity. It is made of massive timbers laid horizontally, being raised from the ground on pillars of solid trunks of trees eight or ten feet high. It is said to have been examined every sixty-first year since its building, that is, at the beginning of each cycle, and repaired when necessary. What is more astonishing is that the objects deposited there by the Mikados have been kept in perfect safety from the eighth century down to the present time, having escaped the danger of fire, robbery, and turbulent times, those destroying agencies which in no other part of the world, probably, have ever allowed any building of importance, much less a wooden one, to remain intact for so long a period. Some fresh objects have in the course of centuries been added to the original collection, but those which belong to the first deposit are all named in an inventory made in the eighth century which was deposited with them, and they can thus be identified and distinguished from recent additions.

“This being the age of exhibitions and popular instruction, it came into the head of some antiquary that it was time to bring to light the long hidden treasures of the Nara repository. Hence the Nara exhibition, which has been visited by many foreigners during the present summer, although we suspect

that very few have had any idea of the extraordinary character of the objects exposed to their view. We have, it is true, in Europe marvellous collections of the antiquities of all ages, which have been brought together piecemeal. The genuineness and exact date of some of these objects can be ascertained, but how many of them are damaged and mutilated from the vicissitudes they have undergone, and of how many is the history and origin more or less open to question? What would the antiquarians of Europe say if an ancient building containing the household furniture and effects of Charlemagne, with a catalogue of the same made under that monarch's immediate direction,<sup>1</sup> were now to be opened for the first time, and the contents announced to be on view, all in fine preservation! But of such a kind is the exhibition now offered to the eyes of Japanese antiquaries.

“The temple of Dai-butz affords a convenient locale for the display of these curiosities. The objects brought from the royal magazine are arrayed in the area immediately round the great statue, on each side and behind it. In the outer galleries or cloisters which form the exterior of the temple is a still more extensive collection of antiquities, contributed by various temples or by private possessors. To some of these objects a still higher antiquity is attributed than that of the contents of the Nara magazine, and the very remarkable character of several which we have inspected induces us to think that this belief is well founded, although we do not know exactly what external evidence of their age exists.

“Amongst the curiosities belonging to the Nara Mikados of the eighth century may be mentioned screens, pictures, books, sculptures, masks, of which there is a very large collection, pottery, and glass, copper bowls and dishes, spoons, soap (!) in large round cakes the size of quois, tortoise-shell back-scratchers, beads and ornaments, bells, weapons and utensils of various kinds, dresses, hats, and nondescript articles. Probably the larger part of these things are of foreign origin, and principally Chinese. The eighth century was the middle period of the great Tang dynasty (A.D. 620-907) and the books and pictures here collected are a rich field for the study of Chinese art and literature during that time. Some poetry which we saw struck us as more likely to be Indian or Persian than Chinese. A jug or ewer of white glass, about a foot high, excited some incredulity as an object of the eighth century. We were told by one informant that it was not to be found in the original inventory, while another antiquary, who is engaged in studying the collection, assured us that it is there. A specimen of Chinese writing paper was remarkable for the freshness of its appearance—smooth and unstained, it might have been just produced from the mill. The miscellaneous collection in the outer cloisters embraces objects of various ages, from some alleged to be one

---

<sup>1</sup> Charlemagne is said to have been so particular that he had an exact register furnished him of the number of eggs which the hens laid upon his property.

thousand five hundred years old, down to those of the time of Taiko-sama. The most antique of these curiosities are certain bronzes which have an Indian character, and some statuettes of clay (?) which remind one of Greek work more than anything else. Some wooden statues, of nondescript physiognomy may perhaps be Corean. We saw one picture ascribed to a celebrated Corean artist, of remarkable merit. The best pictures, on the whole, are those attributed to Chinese artists, or copies from such. The Japanese are great lovers of autographs, and there were many specimens of this class of relic—notably writings by Yoritoma, Taikosama, and Ieyasu. It would be impossible from two days' cursory inspection of the Nara exhibition to give more than the faintest idea of the value and curiosity of its contents. It is evident that here are the materials for the study of Indian, Chinese, and Japanese antiquities, such as are not likely to be congregated anywhere else, and it is satisfactory to know that Japanese antiquaries of high attainments are engaged in cataloguing and describing the collection.

We have been reading and preparing ourselves for the sights of the morrow; and it may be worth while to mention that while gold was first found in Japan in the year 749, the great Dai-butzu of Nara, which was made in the fifteenth year of the reign of Shomu Tenno, or in the year 739, was covered with this precious metal, hence the gold employed in this vast work had been entirely brought from foreign countries.

Saturday the 3d of February 1877 will always remain a great day in my history. We are up at seven, and after breakfast start with one of the Museum officials from Tokio, who has been sent to conduct us to the treasury and the sights of the town. First, we see a temple consisting of several buildings; but here, as everywhere else in Japan, much has been destroyed by fire. Originally the garan or complete temple (or, as we should say, group of temples) consisted of a number of buildings, one of which was the main temple or kon-do, one a pagoda or tō, one the eating-house or shioku-do, one the lecture-room or saidono, and one the bath-house or yuya. Some of these have been destroyed by fire, while one, the southern round temple or nanyen-do, has been rebuilt. From time to time, buildings have been added, and if the whole were now standing, they would consist of a pagoda or tō, a southern round temple or nanyen-do, an eastern golden temple or token-do, a western

golden temple or saikin-do, a chief temple or kon-do, a lecture-room or ko-do, a northern round temple or hokuyen-do, a bath-house or yuya, a building termed an anteroom or hosodono, and a refreshment-house called shioku-do; but of these all that now remain are the pagoda, the eastern golden temple, the northern round temple, and the southern round temple which has been rebuilt, but the three old buildings which still remain have been in existence about twelve hundred years.

Under each of the main temples of one of these groups of sacred buildings it is customary to bury seven pieces of precious material; indeed, the Buddhist scriptures enjoin the performance of this rite. The materials prescribed for this purpose are pearls, gold, silver, agate, coral, amber, and a kind of shell called by the Japanese *shako*, which appears to be that of the *Squilla mantis*. In the new or southern round temple is a great Buddha (not the great Buddha of which we read last night), but although its proportions are colossal, it is not very visible, being enshrined in a large and ill-lit building, where it is seen only through white curtains partly drawn. In front of this colossal figure are many sacred vessels, indeed, so many, that with the image and its surroundings the temple is filled almost to the door, and no one is allowed to enter the building save the priest. The disappointment to me caused by this arrangement was great.

The northern temple of this group contains another Buddha and a number of other idols, besides an immense pile of blocks used for printing the Buddhist scriptures, but this Dai-butz is comparatively small. The blocks used for printing the scriptures are about twenty inches long, nine inches broad, and an inch and a half in thickness. The grain of the wood runs throughout the length, and they are engraved on both sides, the engraving, however, only extending within two inches of each end. These blocks are engraved much like those with which we print wall papers, that is, the portion which is to receive the ink and produce the impression is left standing, while all the intervening wood is cut away to the depth of about one-eighth of an inch. The unengraved end-portions of the block are reduced

to the thickness of about three-quarters of an inch, and serve only as handles.

It may be thought that in speaking of these printing-blocks, I ought to have compared them with the blocks from which we print our woodcut illustrations; but the reader will better understand their nature by the parallel which I have drawn, for our woodcuts are engraved upon wood with a vertical grain, whereas the blocks of which I speak have a longitudinal grain. Our woodcuts also are engraved with great fineness, and the sunk parts are but little below the general surface of the block, whereas both our wall paper blocks and the Japanese blocks of which I speak are cut more deeply and in a more simple manner.

In this temple are also many small gods formed of wood; indeed, there are piles of such, they being the remains of a thousand figures, which were formerly arranged together in the manner of the members of the chorus at one of our great concerts; and of the old arrangement of these gods they show us a model. I am struck with the simplicity of treatment which these figures present, and with the crispness and beauty of their folded drapery, indeed, the treatment of the drapery reminds me by its simple excellence of the best sculptured works of our own mediæval times; and between some of these figures and those with which we are familiar in our own cathedrals there is a striking resemblance (Fig. 25). Seeing my interest in these works, the priest presents me with two.

They are about eight inches in height, and while one is tolerably perfect the other has in part crumbled away through the effects of time.

In the eastern golden temple there is another Buddha, and many curious idols, some of life size, some larger, which evidently represent peoples of various nations. The priest now tells us,



FIG. 25. SMALL GOD, OR  
STATUE, CARVED IN  
WOOD.



that some of these idols were presents from China, others from India, and that it is not uncommon in Japan to find presents of this description in the great Buddhist temples.

This temple, like the last we were permitted to enter, is much out of repair; indeed, what is here stored is all falling to decay. A number of coarse earthen vessels made about a hundred years since, and resembling in form a modern tea-cup of the country, with a particular form of stand on which the cup is often served (only in this case, the cup and the stand are larger than those of the present day and are united together), are here, as well as one of those curious mace-like censers, consisting of a bent stem of the *Nelumbium* (or Buddhist lotus) such as I saw in Tokio (Fig. 19). This censer has a flower and leaf at the end, the flower ascending and the leaf descending, while in the centre of the stem there is a young and unexpanded leaf. This object was made about a hundred years ago, and while I have only seen it upon an altar, I am informed that Buddha holds it in his left hand when he prays for his mother, and that incense is sometimes burnt upon it.

Seeing my admiration for both the cups and this censer, the priest presents one of the former and the latter to me, and I have no compunctions of conscience about taking them, for all is here perishing; and soon, unless things greatly change, all will be ruin and desolation. Under the Shôgunate rule these monuments of antiquity were carefully preserved; but the present Government seem to consider it no part of their duty to guard from destruction these ancient buildings and their contents.

We next visit the pagoda, which is a splendid structure of remarkably fine proportions. There is a great difference between the pagodas of Japan and of China. While the latter are nearly always uninteresting and possessed of little beauty, those of the former are invariably both graceful and beautiful. In China, however, the pagodas are much more varied in form than in Japan. Our priest-guide opens for us the door of the pagoda, and upon entering, we find a few idols arranged on its basement floor. By climbing, scrambling, and squeezing through spaces which

are almost too small for me to pass, I reach the upper gallery, from which we have a magnificent view of Nara and its surroundings. I am now informed that I am the first European who has been permitted to ascend this pagoda, and that I am the first to whom the eastern golden temple has ever been opened.

Time is passing, hence we cannot tarry longer at these temples ; but we must not leave without inspecting an old

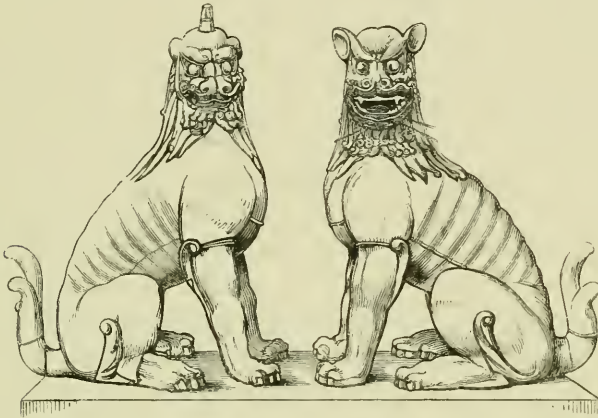

FIG. 26.—LIONS OF COREAN WORKMANSHIP, GUARDING THE GATEWAY OF THE GREAT TEMPLE OF TODAIJI IN KIOTO. It is impossible to view these without the thought of the lion and the unicorn being awakened in the mind.

coniferous tree in the grounds, the branches of which spread horizontally with great grandeur. The Japanese are particularly fond of old trees, especially of the species of fir and other cone-bearing plants ; propping up their branches with great care and securing them so that neither storm nor tempest shall lop them off. From tip to tip the horizontal branches of the tree before us measure one hundred and forty-eight feet. We now give a subscription to the temple, bid adieu to the priest, and leave.

Walking nearly a quarter of a mile we arrive at the temple of the Great Buddha (Dai-butzu), the largest in Japan. This is the temple of Todaiji, built eleven hundred and thirty-one years since. At the gateway stand two stone lions (Fig. 26)

supposed to be of Korean workmanship. In the porch, at the first gateway, are two colossal standing gods or niwo = kings, one with a club of a form common in Fijian weapons, and whose name is mitsshaku kongo; the other bearing a brazen mace, such as a Buddhist priest holds in his hand while praying, and named narayen kongo. This porch, in which these deities have for so many years stood, is of vast proportions, its chief wooden uprights (or pillars) being one hundred feet in height by twelve feet in circumference. Having passed this colossal gateway we go through a second of similar proportions, then across the courtyard to the temple itself, wherein the great Buddha is enshrined. This Buddha, fifty-three feet in height, almost fills the enormous temple, for it has a nimbus eighty-seven feet in diameter, on which rest sixteen images, each eight feet high. Its face is sixteen feet long by nine feet six inches broad; its shoulders are twenty-eight feet seven and a half inches broad, while nine hundred and sixty-six curls adorn its head.

The temple in which this great figure rests (in sitting posture) has been twice destroyed by fire. During the last fire the head of the figure was much injured and loosened, and shortly afterwards it was thrown down by an earthquake, when a new head was cast. The head of this figure I do not like nearly so well as that of the Great Dai-butzu at Kamakura; and indeed it is much inferior to that of the other parts of the figure. The new head was cast in the sixteenth century.

Our visit to this temple is necessarily short, while there is enough met with here to interest any student of the past, whether he be artist or antiquarian, for days if not weeks; but as we are keeping Mr. Machida (who is to show us the great collection of antiquities) waiting, we must hurry on. Having reached our destination and renewed our acquaintance with him, we begin our inspection of the collection of ancient objects in Nara, and find the first part in corridors surrounding this temple of the great Buddha. The objects here displayed are arrayed chiefly in plain pine-wood glass-fronted cases, so fastened that any tampering with the contents may easily be detected, for, instead of being furnished

with locks which, as made in Japan, may be easily picked, they are simply fastened by twisted strips of tough paper strung through two clasps and knotted together, while a red stamp is impressed upon the folds of the knot. The stamp used for this purpose somewhat resembles our old-fashioned seals, only it is formed of wood, and the part which is to yield the impression is raised and not sunk. This seal is charged with a kind of red paint, and then pressed upon the knot of the soft paper-string. It is obvious that a contrivance of this kind will do nothing in the way of keeping out a thief; but it cannot fail to show whether the case has been tampered with or not, for if the knot has once been untied it would be quite impossible by any amount of adjustment to bring all the parts of the impressed seal again together in proper relation to one another.

Through the kindness of Mr. Machida these seals are broken whenever I wish to investigate any object, and I feel it to be indeed a privilege to handle and examine these rarest of antiquities. Here are sword blades one thousand three hundred years old, which are made of copper, but these belonged to the gods (idols), and came from a temple called Horiu-zi (zi means church). There is a large iron shield about six feet in height, in every way well wrought; but its age is unknown. On a saddle, known to be about one thousand years old, is a conventional Persian-like peacock, wrought in *repoussé* brass, which is very good. A Chinese vase, which has been here preserved for over a thousand years, and has a black ground, with a spray of bamboo and certain rocks wrought upon it in gray, is interesting. There are wood carvings of lions executed with great spirit and "feeling," but the ages of which are unknown; two sceptres, the one being one thousand three hundred years old, while the other is one thousand years of age. There is a thin iron bowl most beautifully shaped, the bottom of which has been patched; this is a thousand years old; such vessels were formerly carried through the streets by priests, who held them out for the purpose of receiving offerings of rice.

One piece of bronze-casting, which has been preserved in the

Mikado's collection ever since the inventory was made a thousand years since, is as perfect a work, of its kind, as any that I have ever seen. It is the frame of a sacred gong, and consists of two dragons entwined together and standing on the back of a griffin. In another work a lotus flower cast in bronze springs from an ornament consisting of flames superposed on water—the water and the heat producing vegetation reaching up to the spirit or god (Buddha) that sits on the flower. The age of this

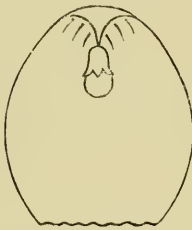

FIG. 27.—PETAL OF A LOTUS (*Nelumbium*) FLOWER, preserved in the Imperial treasury, with crystal drop in metal socket hanging from its apex. Each of the outer petals of the flower had this jewel.

work is unknown. Another lotus of great age, in which the petals are all tipped with a crystal drop (Fig. 27), and a small clay figure with the hair so arranged as to resemble exactly what we know as the jester's cap with ass's ears, occur in the collection. Of things which have been added in later years there

is a tunic, evidently of Chinese workmanship, with a richly-embroidered collarette in gold and colours; long shoe-like stirrups on which the foot would rest, and which superseded, about five hundred years since, the earlier form of stirrup where the front part of the foot was incased in a truncated cone. There are one or two simple pieces of furniture, being chairs and a small cabinet, six hundred years old, both used on ceremonial occasions, and several pieces of armour which belonged to that warrior to whose memory a temple was built at Kobe (Hiojo), and in front of which I saw the beacon fires during the time of the illuminations a few days since.

There was also an entire row of Chinese Celadon vases (each of about twenty-two inches in height), some having the sea-green glaze on white, and others on red, earth. Certain of these bear bands of Chinese ornament or sprays of foliage wrought upon them, while the ornament on others is obviously Indian in character. But the most curious object in the collection is perhaps a lamp of singular formation (Fig. 28). Here the oil is stored in the body of a rat which sits upon the top of a pole. Half way down the pole and resting on a projecting bracket is a saucer, in the centre of

which is a pin that connects it with the bracket on which it rests : in this saucer, and leaning over its side, is a wick. When the saucer is filled with oil and the wick is lit we have a lamp which exhibits no peculiar qualities till most of the oil has been consumed. Then suddenly a stream, which suffices to replenish the now nearly exhausted saucer, issues from the mouth of the rat. The saucer being full, no more oil is discharged from the rat's mouth till it is again nearly empty, when the kind creature sitting "up aloft" yields a further supply, and so on till its store of oil is exhausted. The manner in which this is achieved is simple, although the effect produced is curious, for it is only an application of the principle of the vent-peg or pipet whereby fluid cannot run from a vessel unless air is admitted to take its place. The peg which rises in the centre of the saucer and attaches it to the support on which it rests terminates in a knob or cap ; but the peg is hollow and is connected with the body of the rat by a tube which runs along the bracket and then ascends through the stand to the upper portion of the rat's body. The pin which stands in the centre of the saucer, it should be noticed, is perforated immediately below its cap, or about half an inch above the bottom of the saucer. It is obvious, then, that when the oil sinks to a point at which this hole is exposed air will enter and thus allow the oil to run out of the rat's mouth ; but when this hole is again covered by oil, no further air is admitted, and therefore no more oil can run from the rat's mouth.

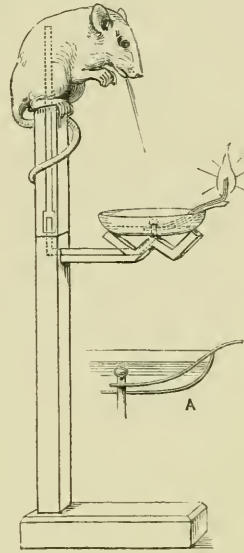

FIG. 28.—CURIOUS LAMP, preserved in the Nara treasury. The construction of the lamp is indicated in the rat's body and in the upper part of the stem on which the rat rests, as well as by the detail, A. The lamp is about two feet in height.

From this part of the collection we walked to a building some two hundred yards distant, which contains a second and much more interesting series of objects.

This portion is arranged in a kind of entrance-hall and in one

large room, and Mr. Machida informs us that everything in the room is known to be at least twelve hundred years old ; but all the objects are not Japanese, nor is he able to say whence many of them have come. Some, however, are obviously Chinese, and some Indian, while several, which are half Chinese and half Indian in character, are perhaps from Tibet, Yarkand, or other inland country lying near to India and China.

In this room we have a magnificent collection of art objects, which have found their home in Japan for at least twelve hundred years. But what interests me most perhaps is the woven fabrics, for these, while of this great antiquity, are in perfect preservation, and are thoroughly mediæval and Italian in the style of their patterns. Had I not known to the contrary, and had I made but a cursory examination, I should have supposed that certain specimens from the Bock collection in the South Kensington Museum had been lent for exhibition here, while others were more Arabian in character.

One of the Arabian-looking fabrics reminded me strongly of a plate in that magnificent work *l'Art Arabe*, in which a similar fabric is portrayed (see plate entitled *Etoffe de tenture*, XII.<sup>e</sup> siècle). In the specimen here at Nara the pattern consists of circles regularly distributed, both horizontally and vertically, and separated from one another by a distance equal to about half their diameter. These circles are fringed by a sort of Arabian ornament, of such width that these fringes of the various circles almost meet. In each circle are two conventional lions, face to face, while in the spaces intervening between the circles are other small animals. Red and dull yellow is not an uncommon combination of colour in these Arabian-looking fabrics here.

There are printed cotton fabrics of this period also, where the figure is usually white, on some plain coloured ground ;—the colour of the ground having, obviously, been removed by a colour-discharging agent, while others appear to owe their pattern to the figured portion of the fabric having been protected from the action of the dye by what is technically termed a “resist.” Belonging to this remote age, there is also a very

fine piece of leather, about fifteen inches by two feet six inches in size, of pleasant yellow-brown colour, and with a pattern consisting of white lines arranged in the form of well considered scrollwork, and a *cloisonné* enamel dish, with the wires projecting from the body about one-sixteenth of an inch. The enamel in the cells is, however, concave, for the surface has never been ground down. Of the same age are certain most excellent metal mirrors, some being circular, and one being square; but some of these (probably all but one) are of Chinese manufacture. The one that is certainly Japanese is circular, and about fifteen inches in diameter, and the pattern on its back closely resembles those which are now to be found on similar objects. One from China has its back figured with a geometrical pattern of Celtic character; but the Japanese mirror has a case covered with a silk fabric of mixed colours,—gray-white, yellow, blue, and dull red; all of which are outlined with black, and fall on a green ground. The pattern of this fabric is in character between Persian and that kind of flat ornament which is general as the background of pre-Raphaelite pictures. There are some grand pieces of Indian embroidery, in which the simplicity and purity of the ornament is delightful. These certainly surpass in tenderness of line, precision of form, and just distribution of the parts, anything that I have before seen of the kind; and they have been in Japan for twelve hundred years.

There are vases of various kinds, some Greek in form, others Arabian in character, some Chinese, and some Japanese. One with black ground and bands of incised red lines might be a work of the best Athenian age, were it not for certain nondescript characters with which its surface is in part covered. There is a glass ewer with a well-formed lip, and somewhat elaborate handle of very pale blue-green colour, and rather rough texture (like some of our pickle bottles), but the Japanese do not know whence it came; they only know that it has been in possession of their emperors for one thousand two hundred years. To me it is obviously an Arabian work, and the appearance of the glass closely resembles that of the pendent enamelled lamps which



have during the last few years been brought from Egypt and purchased for the various European museums (Fig. 29).

There is a metal jug of tall proportions and Persian shape, having around its body a row of gilt animals with engraved outline, a Japanese metal water-bottle with low and curious spout covered by a lid; and I may here add that a spout rising to the level of the orifice of a vessel seems to be a late invention in Japan; for it is not observable, so far as I see, on any native vessel in this collection.

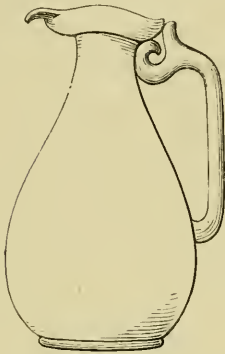

FIG. 29.—ROUGH SKETCH OF A GLASS EWER, preserved in the Mikado's treasury at Nara. It is undoubtedly an early Arabian work.

There are leather bags, such as were tied around the wrists of archers to prevent the arrows cutting them, a double-headed trident used in ancient times for the catching of madmen, a box covered with basket-work and in part lacquered, a *repoussé* brass tray of sixteen inches in diameter, with a stag in high relief in its centre, two very wonderful basso-relievo carvings in white marble, and as perfect and sharp as the day they were cut. The subject of these is a snake, mythological animals, and conventional clouds. These are undoubtedly Indian works, and of great excellence. There are two plates (each fifteen inches in diameter) of white biscuit-ware, with pattern consisting of goose and flowers in yellow, and an earthen bowl, the top of which is green and the sides striated, the stripes being due to the running down of the marginal green glaze over the white ware of which the bowl is formed. There is a coarse white fabric with brown pattern printed upon it; but I was specially interested in a number of pieces of thick felt each four to five feet square, which are well made and have most charming and simple patterns of true Indian character wrought upon them by the entangling of woollen yarns with the hairy surface of the fabric. Similar fabrics are now made in Persia; but the patterns of these old works are simple and pure, while those now manufactured are figured with ornaments indistinct and of complex character.

As the process by which these felt cloths are made has never been practised, so far as I know, in Japan, I may briefly describe it as we here find specimens which, although twelve hundred years old, are the best of the kind that I have ever seen.

On a floor is spread a quantity of short hair, generally that of the camel, which is felted, or made into an unwoven cloth, by being sprinkled with water to which a little acid has been added, and then rolled with a stone roller or beaten with stones or clubs. This beating or rolling, when continued for a sufficient time, achieves the close intermingling of the hairs, or the felting of the fabric. But before the felting is quite complete, coloured woollen yarns but imperfectly spun are arranged loosely upon the surface of the now nearly formed fabric, and by manipulation of the thumb and finger (which is in part a twisting process) are so united with the protruding hairs of the felt that, by the completion of the felting process, a homogeneous fabric is formed with figured surface.

Leaving the large room, we now go to the hall, where the exhibition consists wholly of fabrics, believed to be from five to eight hundred years of age. There are here also many cloths of old European and Persian types, but where they came from is quite unknown.

I examined the collections as carefully as possible under the circumstances, for Mr. Machida, who is in charge of them, dared not leave us, and I was afraid of tiring him out. There is no museum of antiquities in the world, so far as I know, half so instructive to the European as this rare collection at Nara. Where else could we see fabrics printed, embroidered, and felted, and, although more than a thousand years old, almost as fresh as on the day when they first left their makers' hands in India, Persia, Central Asia, China, and Japan? Where else could we see these strange connecting links between the arts of Egypt, India, China, and Japan, that we find here? We are now taken to see the massive structure which has sheltered and preserved this little world of wealth for over a thousand years, and, strange to say, it is a mere large oblong building formed of triangular logs of *wood* (Fig. 30).

These logs are arranged like those of a Russian timber house,

and after crossing at the corners protrude like the sides and ends of an "Oxford picture-frame." The building thus formed stands on a series of circular wooden columns of about five feet in height

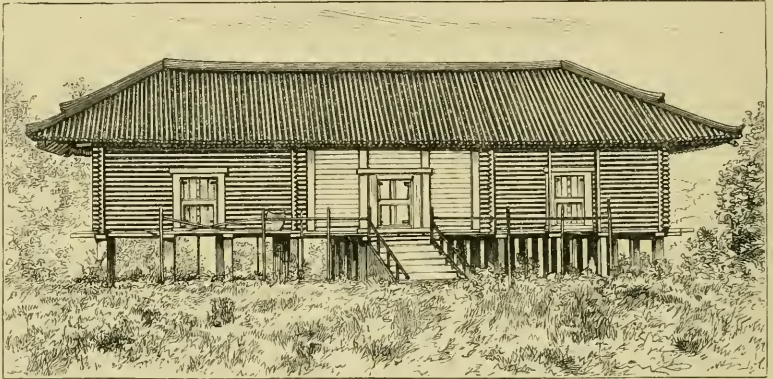

FIG. 30.—The old Wooden Building in Nara in which the Mikado's treasures have been preserved for twelve hundred years. The roof has been renewed from time to time, but the other parts of the building remain as first erected. This is, probably, the oldest wooden building in the world.

and two feet in diameter, and each one of these rests loosely upon a stone; the roof is of tiles, but that which now covers the building is comparatively modern. The roof which was placed upon the building when it was first erected was replaced by a second, and this, in its turn, gave place to a third about five hundred years back, and this was replaced by the present about one hundred and fifty years since. Mr. Machida kindly gives me a portion of a tile from each of the two latter roofs.

In looking at this ancient building one is perhaps most struck with the fact that wood which has existed for a thousand or more years, and has been exposed to an atmosphere at least as trying as that of Great Britain, should have endured to the present time; and, more surprising still, the wood is at this moment as sound as it was when it was first placed here. In some cases it is much worn by the action of the weather, indeed, I observed that where a log was exposed it was three or four inches less in diameter than where hidden, yet the wood was not decayed; but the Japanese seem to have an almost imperishable wood. We boast of our oak; but what is oak when compared with wood that has

actually resisted the storm and the blast for over twelve centuries, and is still as sound as it ever was.

Mr. Machida now orders the large and curious padlocks to be taken from the doors of the storehouse. Upon passing the entrance we find it divided into three compartments, all of which are filled with large wooden chests; and it is in these chests that the Mikado's antiquities have been preserved for so many centuries.

To my astonishment I find that only one-third of the Mikado's rare treasures at Nara have been unpacked. What this vast number of great trunks may contain I cannot possibly say, but in all probability there are here objects which would throw light on many subjects now imperfectly understood, and would do much towards perfecting a history now unknown to the world.

We were about to bid our host adieu, when he begged us to return to the building where we saw the oldest of the treasures. as here there was a small object which he desires me to accept. This he terms a pagoda, but in reality it is a turned piece of wood, some six inches in height, with a base and discs protruding horizontally one above the other. It is hollow, and the orifice is closed by a pear-shaped wooden stopper, but the great interest of this little object lies in its containing a specimen of the first printing ever effected in Japan.

When the art of printing was introduced to the country the first work performed was the reproducing of one passage of the Buddhist scriptures. The copies of this passage were incased in these little pagodas and deposited in a temple. It is said that a million of them were placed here, but there is much difficulty with numbers, owing to peculiarities in the language and difficulties of translation. I was once shown a god which was said to be the god of a thousand arms, but when I inspected it I found that it had only sixteen of these appendages. However, it is certain that a vast number of these little pagodas did at one time exist in the temple at Nara, and I could believe anything respecting Japanese patience and toil, but unfortunately they have nearly all disappeared; and this most interesting gift is worm-eaten and decayed. Yet the letters on the little enclosed roll of paper are readable to this day.

## CHAPTER IV.

The sacred dance—A feast night—Kioto—The royal collections—Osaka.

HAVING visited one or two other temples, we return to our hotel and to a native dinner, after which we go by invitation of Mr. Machida to see a religious ceremony consisting of music and dancing—a ceremony the performance of which is purchased at considerable expense—but our good host has had everything prepared for us, and has sent some Government officials to accompany us to the temple.

It is the night of a sacred festival, and all Nara is astir. The streets are also decorated, as the Mikado is expected to visit the town within the next day or two. Bamboos stand at either side of the streets at distances of about twelve feet apart, and these are connected by festooned straw bands which hang at a height of six feet from the ground. From these straw bands hang the cut papers symbolising the Shinto religion. We now turn into an avenue of gigantic cryptomeria trees,—the grandest avenue I have ever seen—where are stalls rendered gay with lanterns, on which are sold toys, sweet stuffs, and other trifles. Leaving this by an avenue turning on the right, we behold a sight which I shall never forget. Here is one of the most lovely of groves, formed of colossal coniferous trees, with innumerable stone monumental lanterns at either side. These lanterns vary in height from four to ten feet, and nearly every one is lit (I afterwards learnt that there are two thousand two hundred lanterns in this grove.) Every now and again we come to little flights of rude steps, for the avenue ascends the slope of a rounded hill. This rising

ground, the flocks of gaily dressed people who are going to the temple to pray, and the strange aspect of this vast forest of stone lanterns, produce a scene in the highest degree surprising.

At the top of this beautiful grove, amidst a vast crowd of lanterns, rises the temple called Wakamiya. It is celebrated for its thatched roof, the thatch being very thick and regular, and consisting of layers of the inner bark of a fir-tree. This roof is the most perfect of its kind in Japan ; and near the temple is a shrine containing a god, which is so sacred that even a priest may not enter its abode. Facing this shrine, but at the opposite side of the road, is what is called a "priest's house." In this the religious service which we have come to see is to be performed.

This house is a long building with its side to the road. The room that we enter is a parallelogram. Its windows, which form the entire road-side of the room, are heavy frames filled with coarse lattice-work, over which no paper is strained. These frames, hinged at the top, open inwards, and when open are supported in a horizontal position by hooks from the ceiling.

On this the evening of our visit the whole of these side windows are open, hence whatever takes place within the room is visible to those outside, and thousands congregate to see the performance of a service in which they evidently all take interest.

At the distant end of the room, as we enter, four priests are kneeling on the floor behind small deal tables or altars, and in front of a large folding-screen, on which deer are painted. One has a flute, another a small hourglass-shaped drum, another small cymbals, and the fourth curiously shaped pieces of wood, which are knocked together in the manner of our "bones."

Facing the street, and at the side of the room, are three priestesses and five female children, while along the open side, or facing the priestesses, are five small tables, like those in front of the priests ; these tables bear the rattles, or sistrums, from the handles of which streaming ribbons are pendent.

The priestesses wear red under dresses, and a robe of great beauty, which is chiefly white ; but here and there is dispersed

over its surface a little spray of the westeria creeper in green with a touch of colour,—the green contrasting most pleasantly with the red of the under skirt. Each spray occupies a space of about four inches square, while six or eight inches of space

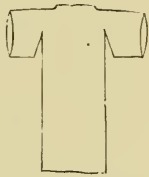

FIG. 31.—Back view of dress of priestess of Nara.



FIG. 32.—Front view of dress of priestess of Nara.



FIG. 33.—Hair of priestess of Nara.

intervene between the groups. When seen from the back, and when the arms are held at right angles to the body, the dress has much the form of the letter T (Fig. 31); but what we may term the shank part does not surround the body, but merely falls as a broad sort of streamer, which, were it sufficiently long to rest on the ground, would form a train.

In front, the shank portion of the T is split down the centre, and the two parts are crossed over the chest; while, arranged as a sort of habit-shirt, there are folds of red, white, and lilac fabrics (Fig. 32). The whole dress is most charming, and the colours employed in it are the Court colours; for the wearers are priestesses of a Shinto temple, and the Mikado is the head of the Shinto Church.

The hair of the priestesses is long and, like that of all Japanese, intensely black. It is not plaited or braided in any way, but flows loosely down the back; only being bound together at the top by a curious flat gold band (Fig. 33). In the front two little tufts of red and white flowers which stick out at the ends of long pins take the position of horns. Close to the priestesses, as they

kneel against the side wall of the room, stand two hexagonal boxes of about eighteen inches in height and eleven inches in diameter, which appear to contain fans. The boxes are covered with leather-paper of golden hue, and the room is lit by candles supported on tall iron candlesticks standing on the ground, and by oil lamps which rest on small brackets projecting from the walls.

We enter the building together with others who have been invited to the service, and range ourselves in rows across the end most distant from the priests, leaving a large clear space between them and ourselves. Now all prostrate themselves, for it is supposed that the god is leaving the shrine opposite and coming into our midst. The priests strike up their music, when the three priestesses and two children rise and begin the dance. The music is very slow and solemn, and the priestesses, who walk across the room with slow and stately step, yet with a slight dancing gesture, prostrate themselves to the very floor in front of the little tables, They now rise, lifting the sistrums from the table, and, with much grace and dignity, move in a rhythmical, yet most solemn and impressive, manner.

For about ten minutes these beautiful motions are alternated with prostration before the little tables on which the rattles are, while at other times the rattles are employed in the dance. After prostrating themselves with the deepest humility before these little tables or altars, where they remain still as death for a few minutes, with the rattles in their hands, they return the rattles to their places on the tables, rise and again kneel in the positions which they originally occupied by the wall.

The next dance is entirely by the five children ; but it differs in no important respect from that just described, and the following dances, for there are five in all, are merely slightly varied repetitions of the first. All are equally solemn, equally impressive, and alike beautiful in the highest and purest sense of the word.

The dances over, all prostrate themselves ; but we are told not to rise from our places. A priest now comes forward, bearing in one hand a small tray of clean unpolished and undecorated pine-wood on which are a few rough, unglazed, small earthen



saucers, and in the other a brazen vessel containing sachi (Japanese wine), and of the size of a small saucepan, but having two semicircular spouts, and a long wooden handle (Fig. 34). A small quantity of the sacred wine (about a dessert-spoonful), poured into a saucer by the priest, is taken from the tray by one of those for whom the dance has been performed. The recipient of this wine now bows and drinks. The priest then passes to

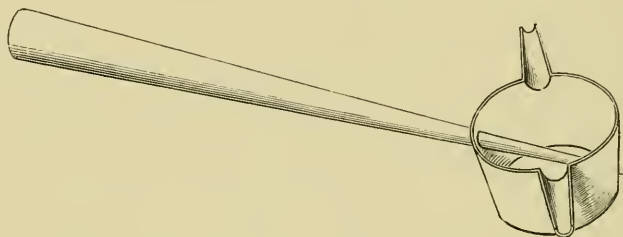

FIG. 34.—BRAZEN VESSEL WITH WOODEN HANDLE.  
Used at the Shinto Sacrament as we use the flagon at our Holy Communion.

the next, pours wine into another saucer, when the recipient of this second portion, in his turn, bows and drinks, and so on, till we have all partaken of this Shinto sacrament. I was aware that the dance is supposed to have spiritual efficacy, and that the wealthy have such dances performed as a means of grace, but I was not aware that Shinto had its sacrament.

We now return home from the sacred house in which we have been so much interested, by the lantern-lit grove, but on our way we diverge a little from our path to see the chief Shinto temple of Nara, that at the top of the grove being only the second in importance in this town.

Here we find eight hundred metal lanterns pendent from the eaves of the roof, and all ablaze with light. And there, opposite, is a large raised wooden platform which is lit by scores of lanterns; this is the playground for the children, and from it comes the sound of the tramping of many feet and the ringing of cheerful voices. All seems brightness and joy and mirth. Amidst the crowd of children I do not hear one cry of sorrow, nor see one unkind look,—all are thoroughly happy.

Much that we have seen to-day has been of the greatest possible interest, and never within my experience has so much been crowded into a few brief hours as on this first day of our visit to Nara.

I have learnt that more than a thousand years since fabrics were made which so closely resemble the finest works of Arabia during the last two or three centuries, that the one can scarcely be told from the other :—That from some part of Asia cloths were derived, so similar to those of Italy immediately preceding the time of Raphael, that the one would pass for the other. I have found that Chinese embroidery was as perfect twelve hundred years since as it is now, and that the patterns on Indian fabrics were in style the same as those produced in the same country only fifty years since, but purer in form, better in design and more beautiful in colour; that the art of felting and giving pattern to felt was better understood at the time when the Saracens were conquering Spain than it is at the present moment. Thus we have the strange fact brought before us that twelve centuries ago India produced fabrics bearing patterns of the greatest purity of design, and without any taint of Hindoo ornament, and that the art of India was at that period better than it is now. We ask, then, at what time Indian ornament as we now know it had its highest development? for it would seem as though a decline, however gradual, has been taking place from that day to this.

I have also learnt that a thousand years ago, in both China and Japan, the art of manufacturing metals was as far advanced as it is at this day; that the art of forming *cloisonné* enamels was as perfectly understood twelve centuries back as it is now; that glass was then formed into ewers by some Asiatic people; that iron could be hammered into the most beautiful and thinnest of bowls; that the Persians made metal peacocks with spreading tails; that wood-carving was as well understood in Japan twelve hundred years since as at almost any later period; that sculptures in marble were as perfect then as now; and that the manufacture of porcelain in China was as thoroughly understood and as successfully practised

then as recently. Thus we find from the collection here at Nara that twelve hundred years have passed over the Eastern world without bringing about any great improvement in most of the manufactures, while in some retrogression, rather than advancement, is painfully apparent.

The fact is also brought before us that but few new manufactures have been invented during the time that these things have been hidden in the Mikado's treasury, for we here find illustrations of weaving, felting, embroidery, porcelain, glass, metal-work, casting, chasing, hammering, damascening, and engraving, of lacquer-work, wood-carving, inlaying, stone-cutting, block-printing, of leather-making and leather-stamping, and of many other arts which time does not permit of my recording; and beyond these but few manufactures have been invented even to this day.

There is one specimen in the collection of antiquities at Nara which interests me much, although I have not even mentioned it up to this time.

We are all familiar with those Bombay sandalwood boxes which are inlaid with tesserae of white metal, ivory, either white or stained green, and sometimes with deep red wood. These boxes, Sir George Birdwood tells us, are but copies of works produced in Persia. Yet the Persian work differs, in one essential particular, from that of Bombay; for while in the latter the inlaid tesserae are brought close together, they are invariably separated in Persian work by a fine brass ribbon, the edge of which appears on the surface. I am not aware of ever having seen a specimen of this Bombay work which could be regarded as anything more than modern; but of the Persian work I have not only seen, but I happen to possess, an example which may date back some two hundred years; and beyond some such date as this I am not aware that we can trace the history of this manufacture. Here, however, I find in Nara a coarse specimen of this work twelve hundred years of age; but where the specimen came from no one knows. In this example the tesserae are in form elongated hexagons of about one and a half inches from point to point in the longest direction, and seven-eighths of an inch in width, and a

metal line separates the hexagons. Here, then, we have evidence of the existence of a manufacture, though, in this case, in a crude state, which, so far as I know, we have only been able to trace back for two or three centuries at the most; and just as this specimen reveals the ancient origin of what we have regarded as a modern art, so it is possible that were the other two-thirds of the Mikado's collection open to our inspection, they would exhibit to us this art in the more advanced stages of its development.

While speaking of Indian manufactures, I may make reference to a box in the collections at Nara, as it was formed of strips of the bamboo arranged precisely as porcupines' quills are disposed on boxes common in India to this day. The narrow strips of bamboo used in the manufacture of this object, and the manner in which they are placed together, render it probable that either this formed the original of the porcupine quill boxes of India, or that these Indian boxes suggested to the Japanese the making of such as we now find in the Mikado's collection. The latter is by far the more probable, for while most of the arts which have been practised in Japan are traceable to the Asiatic Continent, I have not yet succeeded in tracing any Japanese influence on the arts of China, India, Persia, Asiatic Turkey, or any other Eastern country.

Inspection of the Nara collections also reveals this fact—a fact brought prominently into notice during a long journey in Japan—that while the Japanese are the most subtle and delicate of workmen, the most accomplished of handicraftsmen, the most conscientious of artists, they are yet by no means inventive as a race. There is a good deal of truth in the statement that the Japanese have originated nothing, but have improved upon everything which they have seen.

Throughout Japan traces of Indian art are constantly found, while Chinese objects of better class may be seen in the houses of most of the nobles in the land; and I have also found patterns of Persian, Egyptian, and even Celtic character on native work; but of these things I will speak hereafter.

We must always remember that at an early period of its

history Japan was successful in the invasion and conquest of Corea; and this is certain, that many of the arts of Japan, as well as some of its best architectural features, were derived from Corea. Through this peninsula many objects of Chinese manufacture, as well as some from the more central parts of Asia, came into the hands of the Japanese. Indeed, there is in Kioto a collection which, like that at Nara, is also the property of the Mikado, consisting largely of things brought to Japan from Corea by the conquerors of the country. I mention this now only that the relations of this Nara collection to the manufactures of Japan, as well as to the industries of the world, may be better understood.

To-day has also brought us face to face with a religious ceremony of special interest, and a ceremony peculiar to Nara in Japan. We have here, in connection with an early form of religion, a sacrament which is in itself a fact of no little interest; but the most striking circumstance connected with the religious dance of to-night is its likeness to the rites formerly performed by the priestesses of Isis in ancient Egypt. As, however, this matter is referred to in an old number of the *Japan Weekly Mail* I will extract from that excellent journal a portion of an article in which reference is made to this ceremony.

Speaking of Nara, the writer says:—"Here is a Shinto shrine, said to be second in antiquity and importance only to that of Isé. In a building not far from this shrine, and probably connected with it, we witnessed a posture-dance performed as a species of religious ceremony. The performers were three young girls, handsomely dressed, but perhaps less showily than the ordinary *Geysha* (dancing girls). Their movements were of a very solemn kind, and their use of the sistrum or rattle recalled the Egyptian priestesses of Isis, of whose performances this instrument was the unfailling accompaniment. Three priests—one playing a flute, another a drum, and the third chanting with his voice, and occasionally beating time on the two simple pieces of wood—accompanied the dancers. We were informed that performances of this kind were paid for by devout persons much as masses are

paid for by Catholics. There are eight dancers or priestesses attached to the temple. They are the daughters of priests or of respectable inhabitants, and, we presume, the office is considered a highly honourable one."

The next morning we rose early and strolled through the town. We had not got far when our attention was attracted by a carefully roofed wall, the lower portion of which was built of a black rag-stone, and the upper and major part of plaster tinted to a pleasant yellow-ochre colour, along which were drawn five parallel white lines (Fig. 35). On our asking whether this wall surrounded any special building, or whether tinting it and ruling white lines is a mere caprice of the owner, we were told that the yellow wall with five white lines running throughout its length denotes that the building belongs to, or is directly connected with, the Mikado, and that none but those of royal blood can have a yellow wall with any lines upon it, while the number of lines employed indicates the relationship to the Emperor.

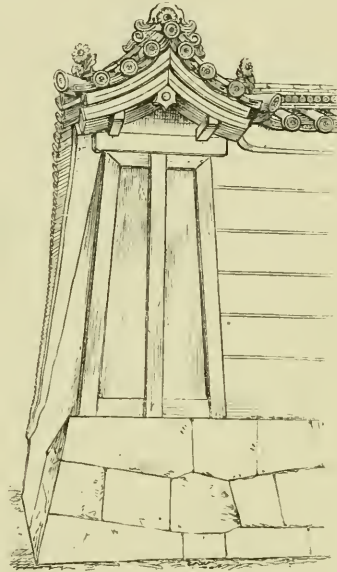

FIG. 35.—END OF WALL. The Wall is of yellow-ochre colour. This colour, and the five parallel white lines, indicate that a person of royal blood owns or administers this property.

Some few years back, when about to send an assistant to Spain and Morocco to make sketches of all kinds of art objects, my good friend Mr. George Augustus Sala said, "Remember Spain is the land of nails." My assistant sent me, from this country, sketches of the grandest nails that I had ever seen, and even some of the nails themselves which he had managed to pick up at curiosity shops. But Mr. Sala was but imperfectly informed on this matter, for Japan is the land of nails and not Spain: and this he would have been the first to admit had he walked with me around the old city of Nara this morning. Here

the temple doors are positively bestudded with such nails as are in the truest sense ornaments, Fig. 36.

A huge hinge is here sometimes attached to a temple door with nails having heads from half an inch to an inch and a half

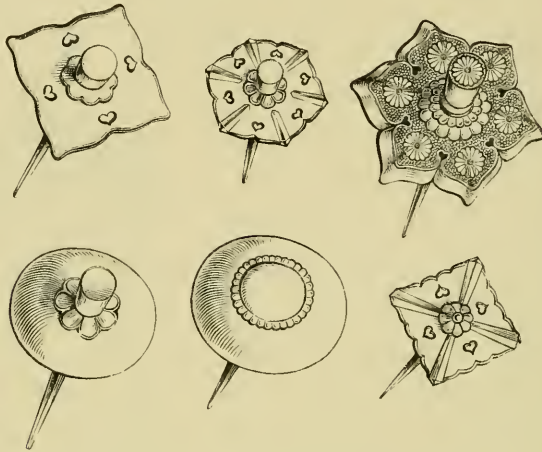

FIG. 36.—OLD NAILS FROM TEMPLE-DOORS IN NARA.

in diameter, while every available part of the door itself is in some cases occupied by nails with heads three and a half inches across.

With these nails I am positively delighted, and I feel constrained to stay and note their forms in my sketch-book; yet while thus engaged I know that I am a drag on my companions. But here we have not only nails but hinges—grand hinges—hinges two to three feet in length. And besides hinges we have metal plates and bindings on the doors. In Nara the old metal-work would supply the art student with material for study, and examples to copy, for weeks; and in no town in the world that I know of can so much that is interesting in this way be found. In Troyes there are many bell-pulls, knockers, and door-handles, which are interesting. Andermatt on the St. Gothard, for a small place, is rich in art metal-work; and in Frankfort on the Main, glorious specimens of hammered-iron still remain to us from mediæval times; but in Nara you are everywhere impressed with the riches possessed by the town in its metal-work.

We now have another look at the great temple of Dai-butzu, with its vast gates, and the more we look at it the more we are lost in wonder. The columns of the gates, as we noticed yesterday, are one hundred feet in height by twelve feet in circumference, while each consists of but one piece of wood, and the building was erected eleven hundred and thirty-one years since, or in the year 750 A.D.

It is difficult to conceive of any building existing for eleven hundred years in a perfect state, especially when it is formed only of wood, and is exposed to the atmosphere; yet such a building is here before me, although it, unlike the old treasury, has doubtless been at times restored.

When such facts as these are considered it seems difficult to understand why we should now be persuading the Japanese to erect buildings of stone and not of wood, especially when it is remembered that Japan is a land of earthquakes. What buildings can we show in England which have existed since the eighth century and are yet almost as perfect as when first built? and yet our buildings rest on a solid foundation, and not on earth which is constantly rocked by natural convulsions.

Besides this the Japanese have, by the medium of wood, produced a characteristic and beautiful architecture. In the great temple of Shiba we have a development of architecture perhaps equal to anything that has been produced by any people in any age. Why then should we lead a nation, which is in itself great, to adopt new methods by which it can only be made to appear small?

Moreover, when a nation that has erected its habitations in any simple manner, has begun to build in more solid material, it invariably appears to retain in the new method of building the traditions of the past. Thus the Egyptians formed the columns of their stone-built temples in the form of bundles of Papyrus reeds; the roofs of many Chinese buildings sway down in the centre, and thus perpetuate in form the bent pole which formed the ridge of the original tent-dwelling, while the walls of the Alhambra at Granada are mere Arab shawl patterns with borders complete, for, while yet nomads, the Arabs formed their primitive



dwellings of the rich tissues which they wove. In all cases, then, we find the more solid building embodying the thought or idea of the original abode of the people.

But history supplies us with a still more remarkable instance of the perpetuation in stone of an earlier method of construction, for many of the rock-cut temples of India are simply copies of works or of a style of work which had pre-existed in wood.

While it is not desirable that any stone building should be a mere copy, either actually or in spirit, of a wooden structure, a nation which would produce a noble architecture must erect such buildings as express the sentiments, faith, and wants of its people, and the buildings erected must be adapted to the particular conditions of climate, and result from a legitimate use of the material most suited to their erection. We, however, have produced in Tokio, the capital of Japan, one or two of the worst specimens of "work-house architecture;" and these the natives are expected to imitate. In this matter we have acted both wrongly and foolishly. Can we show the Japanese how to erect buildings one hundred and fifty feet high, on small bases, so that they will withstand the earthquake? Can we teach them how to raise vast gateways and huge temples in stone so that at the end of eleven hundred years they will find them still standing? I fear not. Hence I cannot help thinking it only right that we refrain from obtruding our advice upon a people who know their own wants better than we do.

We now walked to the avenue, which we saw last night in such gaiety and life; the noble cryptomerias of which it is formed are gigantic indeed. Here we see deer running about, and almost as tame as dogs are with us. Poor women offer to sell us little balls of food, such as the deer like, so we make a purchase and then, at our call, the deer come and eat out of our hands. The deer have the free run of the town, and wander wherever they like. Little images of these deer are the popular toy of the place, just as the bear is dominant in Berne.

We now visit a temple for the purpose of purchasing certain little netsukies which are peculiar to the town. Many of these

are in the form of the deer in recumbent posture ; some are grotesques, while others represent the lobster or crawfish, but their peculiarity consists in their being formed by a number of "clean" cuts, the little carving consisting thus of a series of facets and not of rounded surfaces.

After our return to the hotel, a man brought us some beautiful Nara fans, which we eagerly bought. An old priest from the temple to which we yesterday gave a small subscription also called, and, after greeting us with every mark of respect and kindness, begged our acceptance of some beautiful oranges arranged on a most charming tray. The cloth with which the oranges were covered was a thing to be coveted. Presented in such a manner the oranges must certainly be better than if served from a common basket. It is interesting to notice the beautiful objects which a Japanese, when he wishes to show either his own wealth, or respect to another, will bring from a house that appears to contain nothing but a few domestic utensils.

Mr. Machida now wished us adieu and a pleasant journey, and promised to get copies made for me of some of the grand old nails, which I had to-day seen in the temple doors.

The Japanese love antiquities for their own sake and for the sake of the objects with which they have been associated, and there is much in the Shinto religion which is calculated to stimulate this veneration.

My admiration of the art was mistaken for veneration of the old ; hence Mr. Machida, instead of fulfilling his engagement, by getting nails made in imitation of those at Nara, went to great expense and trouble, in order to procure genuine pieces of old metal-work from some ancient building of especial interest ; thus after my return to England, I received a box with a charming letter from my old friend, in which he says in the quaintest of language, "and I present two ornamental coverings of nail-heads, used in Rashōmon and Congōshuin, and twenty-one old irons to you." To our great amusement, the "twenty-one old irons" proved to be literally "old irons," so far as we could see, with the exception of one or two only. But I value them for the

sake of the giver, and the day may yet come when, by increased knowledge I may discover in them points of interest which at present I am unable to perceive.

As we left Nara for Kioto the sky became heavy. The road was new, having been prepared for the Mikado, who is to visit this town in a few days. On our journey we stopped for refreshment at a little wayside inn, where the inevitable eggs and rice appeared; but they were now welcome, for it was bitterly cold, and half melted snow had been for some time falling.

At this little hotel the Mikado is to stop on his way from Kioto to Nara, and for his reception a new room has been prepared at the back of the house. This room is of clean, unvarnished pine-wood with the usual paper slides, and the floor is covered with matting. Near one end is a raised dais, which consists of mattress-like pads, also covered with matting. A simple openwork lattice runs along the top of the room as a sort of frieze, intervening between the ceiling and the tops of the paper slides, for in all rooms there is this provision for the circulation of air should the slides be closed. In this case the pattern of the lattice is peculiarly simple. In the garden is a small fish-pond of about four feet in diameter, which is well stocked with fish, any of which you may select for your dinner.

There is a charming simplicity about all this. No costly preparations have been made for the visit of the emperor, no elaborately fitted rooms have been prepared, no expensive furniture purchased. The Mikado comes as one of the people, and stays at a little wayside inn, with only one small room as his abode. But that room is perfect in its way: the materials of which it is formed are of the best, and the workmanship is faultless, while there is a look of cleanliness about it which it would be difficult to equal in any country, and impossible to surpass.

Looking at this room and admiring its beauty, we expressed our surprise at the simple taste of the Mikado. We were told that the food which he will partake of is exactly the same as that prepared for the guests at the hotel. To us it seemed strange that a monarch should content himself with such simple surround-

ings, and such common fare ; but on a people like the Japanese this must have a marked effect.

Farther on the road we find a bridge two hundred and fifty yards in length, which has been built in twenty-seven days, so as to be ready for the Mikado to pass over.

At the end of a seven hours' journey we reach Kioto, cold and wearied with the cramped position in which we have been obliged to sit, as the hoods of the jinrikishas were spread. We take up our abode at the Mariyama Hotel—the house at which most foreigners make their home while in Kioto. It is often called the European Hotel, yet it is a thoroughly Japanese building, although it possesses tables and chairs, bedsteads and washstands. After a semi-English dinner, Mr. Saumarez leaves us to join Sir Harry Parkes and the other foreign ministers in a Yashiki, or Daimiô palace, in order to make preparations for their appearance tomorrow in state at the official opening of the railway, on which, as the reader may have gathered, trains have been running for some months past.

While this hotel is by no means small, it is uncomfortably full of visitors, owing to the influx of people desiring to see the ceremony. I have a bed, however, but I should scarcely be justified in saying that I have a bedroom, for my bed is in a strip of a room, divided off from another portion which is also occupied by six-fold draught-screens, such as we use in our own rooms.

Early the next morning, on pushing aside the window-slides, I was more than surprised at the magnificence of the view which lay spread before me. The hotel stands high on the side of a richly-wooded hill, and my room faced the plain which extends at its base. From the balcony surrounding the building I looked down on a grand old spreading fir-tree, a lovely garden, and a richly-wooded slope, while yonder lay stretched far over the plain a vast city. Here and there rose pagodas of beautiful proportion and elegant shape, while beyond the plain were snow-clad mountains, mingled with cloud and mist.

As I looked from my balcony, I could not help feeling that there is a likeness between the lovely view before me and that

which may be obtained behind the Salt Lake City in America. But while the town itself presents but little interest in the one case, it is of the highest interest in the other. The Salt Lake City has a half finished appearance, and consists largely of insignificant wooden houses, while Kioto is most picturesque and of vastly greater size. Both cities, however, stand on plains surrounded by mountains; in both cases the mountains seem to be much of the same height, and in both cases the city is much nearer the one side of the plain than the other.

This is a gala day here: the shops are closed, business is suspended, and the streets are decorated, while people in holiday attire crowd the chief thoroughfares. So dense is the throng near the railway station, that I am compelled to give up the notion of getting within view of the pageant, and to content myself with being a general sight-seer.

In her *Voyage in the Sunbeam*, Lady Brassey speaks of the opening of this railway. It is curious that I should see the Kioto festivities, while Mr. and Mrs. Brassey (now Sir Thomas and Lady Brassey) were observing those at the Kobé end of the railway, and that, while we were both almost treading in each other's footsteps, we should never have met during our sojourn in Japan.

Finding that little was to be done in Kioto for which I could spare time, beyond the sight-seeing, I moved on the following day to Osaka, which I reached after a railway journey of less than two hours. The distance is forty miles, but the trains in Japan run slowly.

Osaka is probably the most important of the manufacturing towns in the country. It is intersected in all directions by canals, and has, for this reason, been called the Venice of Japan. Yet there is very little likeness between the two places, and I should rather regard it as the Amsterdam than the Venice of the country. Here I take up my abode at the Jiyutei Hotel, in the quarter of the town called Kawakuchi, a building two stories in height, and called the European house; but although the rooms upstairs are furnished much like the Mariyama Hotel at Kioto, the ground-floor is without furniture, as is customary in Japanese houses.

The manufactures of Osaka are of many kinds. Much bamboo-work is made here, and also toys of many sorts, pierced and lattice wood-work (Fig. 37), vase-stands and cabinets in hard

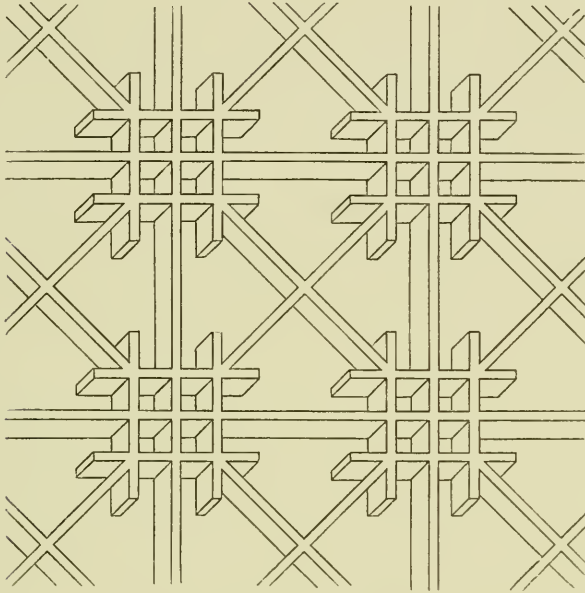

FIG. 37.—PART OF A WINDOW.

wood, like those of China, tea-trays, bronze and white metal kettles, carved lac-work, and many other things.

After studying the manufactures of Osaka for about ten days, I left it by jinrikisha for Wakayama, the chief town of the province of Kishiu, distant about forty-two English miles. We start at 10 A.M., and in two hours (twelve miles) reach Sakai, one of the two towns of Japan in which carpets are made.<sup>1</sup> Here we visit a temple reached by a bridge, the road over which is so convex that notches have to be cut for the feet to rest in, and without them it would be impossible to cross it, even with the help of the handrail with which it is furnished.

<sup>1</sup> Carpets were formerly made by the Prince of Hiezen, but this private manufacture ceased at the time of the revolution in 1868, as the Daimiō system was then done away with.

Soon after leaving Sakai we approached the sea, and saw, at a distance of four or five miles, a glorious range of mountains, which must either be an island or a promontory. On our left, at about the same distance, is another mountain chain, and we are running towards the end of this ridge. In thirty miles we turn to the left, go through a defile, not unlike that of Linton in North Devon, and following a stream to its source, cross the ridge, when a scene which is truly wonderful bursts upon the view. Here a vast plain, having rivers traversing it and lakes like silver mirrors breaking its green surface, has a range of snow-clad mountains as its background ; and yonder a little village nestles beneath us. We now begin a rapid, zigzag descent by following a sort of Saint Gothard road on a small scale, and reach the plain at twilight. The moon is new, but its entire circle is visible, the sky has a few little fleecy clouds flecking it, and the stars come out with great brilliancy. There is a fine "afterglow," but this beautiful light soon passes away.

Our road for the next mile lies across a vast river-bed, consisting of a little sand and innumerable boulders : such valleys are here common. During the rainy season (which occurs in the late spring time) vast quantities of water fall, and, collecting in the valleys, form mighty torrents. As there is but little rain at any other time of the year these rapidly-running rivers gradually become contracted to small streams, which flow in the centres of the river-beds, or, in some cases, entirely dry up. In the middle of this strange, stony valley, over which we have been most unmercifully jolted, we come to the river, which we cross by means of a flat-bottomed boat. This carries us and our *five jinrikishas* across the stream at the same time. In this valley the cold seems almost unbearable ; indeed I never before felt cold at all approaching it ; it seems almost to stop the action of the heart. Yet, in preparation for a thoroughly cold drive, I had dressed myself in a thick tweed suit, thick underclothing, a flannel over-shirt, a wadded silk dressing-gown, and a very stout topcoat, while over my knees I had a large wadded possum skin rug. But with all this I had to borrow from one of our coolies a blanket which he was not using to wrap my head in.

At a little before eight we reach Wakayama. Here is an excellent Japanese hotel, where, after a good meal, in part Japanese and in part English, I write my diary and go to bed.

I have already spoken of the Japanese beds and of the difficulty of keeping warm in them, but I have now overcome the difficulty, in most cases, through a suggestion of my good friend Saumarez, who advised me to take with me while travelling a thick wadded dressing-gown and to wear it as a night-dress. But even this failed to keep out the terrible cold which now prevails in this part of Japan; so I was obliged to retain my thick underclothing, wear my wadded dressing-gown, and then wrap myself round and round in the fur rug. By these means I just manage to keep out the cold.



## CHAPTER V.

The Japanese Calendar—Wakayama—Japanese cold and Japanese vegetation—Koyasan—Splendour of shrines and of scenery—Sakai—News of revolt in Satsuma—Return to Osaka—Feast of the god of riches.

TO-DAY being the 15th of February is New Year's Day in Japan according to the old Calendar. The Julian year and our system of dates was only adopted a short time since ; hence some now keep both days. Most of the shops in Wakayama have been closed to-day, and general holiday has been kept. This year, 1877, is, according to Japanese chronology, 2537, from the beginning of their empire. It is strange that there has never been, as far as is known, anything like a Sabbath in Japan until last year, when one was proclaimed by the Government ; but thus far this proclamation has affected only the Government officials, for shops are open and business is transacted on all days of the year, save on the great holidays and on the feast days of their favourite gods.

Under the old system of recording time many difficulties arose, for the same year was constantly recurring, and to specify any particular year reference had to be made to the reigning Mikado as well as to the name of the year ; and, curiously, the hours of the day bore the same names as the years in a cycle. The Japanese day, however, from midnight to midnight, was only divided into twelve hours, each as long as two of ours. Their clock also differed essentially from ours, time being here marked by a small horizontal hand, which slid down a scale, resembling that of our thermometers.

The names of the years in a cycle and the hours in the day, to which latter are added the hours of our time indicated, are:—

Ne, mouse . . . . .	12 at night.
Ushi, ox . . . . .	2 A.M.
Tora, tiger . . . . .	4 A.M.
Uw, hare, . . . . .	6 A.M.
Tatsu, dragon . . . . .	8 A.M.
Mi, snake . . . . .	10 A.M.
Uma, horse . . . . .	12 noon.
Hitsuji, sheep . . . . .	2 P.M.
Saru, monkey . . . . .	4 P.M.
Tori, cock . . . . .	6 P.M.
Inu, dog . . . . .	8 P.M.
Ie, boar . . . . .	10 P.M.

The year A.D. 1877 is the year of the boar, the preceding year being that of the dog.

Wakayama is a town of medium size with several industries, but it is especially celebrated for its oranges, and here in the little garden of our hotel, bitterly cold though the weather is, are two trees laden with golden fruit.

For the strange fact that semi-tropical fruits, and almost tropical plants, will grow in a country where there is such intense cold I can account only in this way: even in the depth of winter the sun yields such heat as, in almost all cases, to melt the frost of the preceding night, and thus the cold never penetrates deeply into the ground.

I have seen pendent from the eaves of a house icicles a yard in length, which have been formed between sun-down and sunrise; yet I never saw ice on which I might venture to walk, save once, and that was on a small pool entirely protected from the sun's rays by an overhanging rock. It is possible that in a highly volcanic country like Japan subterranean heat may have something to do with keeping the roots of plants warm. Whether any observations respecting the earth's temperature at varying depths have here been made or not I cannot say; but the fact remains that we have the orange luxuriating, the tea-plant flourishing, the bamboo acquiring colossal proportions, and

here and there a palm-tree in a sheltered spot, while the cold experienced is sometimes almost Polar.

It is morning; the sky is almost cloudless, but the weather is very cold, and ice is everywhere, yet we perform our ablutions on the open balcony.

Our business to-day is to see the lacquer manufactures at a little town ten miles distant called Kuroye-mura, or Black Estuary village, which we reach about mid-day.

The lacquer wares here made are cheap and of medium quality. Some have patterns given to them by scratching. This *scraffito* work is, however, very inferior to that formerly made in the dominion of the Prince of Kaga. Since the overthrow of the baronial system that beautiful manufacture, in its better form, has ceased, and the inferior work of this village and of a few other unimportant places, is all that replaces it, so far as I know.

I am the first European that has ever visited this town, and the whole of the inhabitants turn out to see the wild beast. At Awaji the excitement caused by the appearance of the foreigner was indeed great; but here it knows no bounds. A Government official has accompanied us from Wakayama for my safety, and two policemen join us at Kuroye-Mura for the same purpose. They are certainly useful in clearing our way through the crowd.

On our way back we saw one of the thirty-three Japanese temples of note belonging to a particular sect of Buddhists.<sup>1</sup> It stands high on a mountain-side, and is reached by three hundred steps. The building in itself is not very remarkable, but the splendid camphor-wood tree in front of it, and the view of mountain, plain, bay, sea, and islands, which it commands are more lovely than words can express.

On beginning the descent I felt utterly terrified at the appearance of the steps by which we had reached the temple, although accustomed to heights; for a staircase consisting of three hundred steep steps in an unbroken line, all of exactly the same size, is something fearful to look upon.

This is no peculiarity of the temple of Kimee-Tera. Many

<sup>1</sup> The great temple of Asakusa in Tokio is one of the thirty-three.

temples in Japan stand on rocky eminences, or wooded slopes, high above the road, and almost all temples have commanding and beautiful situations.

On our return to Wakayama I strolled round the town, where I found large cabinet manufactories; but hearing that a pottery in which the well-known Kishiu ware is made is only two miles away I preferred to go and see it. Of the manufactures I shall have to speak hereafter.

At the hotel I found specimens of the native industries sent for my inspection by order of the governor of the town. Amongst these are what we might describe as cotton flannels both plain and chequered, bed-tickings, a kind of arrowroot, Japanese isinglass, preserved oranges, and tanned ox hides—a new and small manufacture resulting from the introduction of the beef-eating European into the country.

Here, for the first time, I saw the “fingered orange,” called by the natives the “Hand of Buddha.” This is a peculiar variety in which a series of finger-like members protrude from the upper parts of the fruit to the length of three or four inches. Apart from this strange variation of form it differs little from the ordinary orange.

Our next excursion was to a city of the greatest possible interest—a city consisting almost wholly of temples, and nestling in a slight depression on the summit of a vast mountain. This city, called Koya-Zan or High Field Mountain, can be reached only by a long day's work; we were therefore actually on our road by 7.15 A.M.

Our way for the first few miles lay in the direction of Osaka; but instead of leaving the river as we should do to regain this town we followed the bank of the stream for twenty-seven or twenty-eight miles, crossing and re-crossing the water from time to time. We were now at the small town of Miōzi-Mura, where we were told that we must take kagos, as jinrikishas cannot proceed farther. We here have tiffin while the kagos are being prepared; but after an hour's delay we are told to go four or five miles farther and then get them, and that jinrikishas can go

on, though with difficulty. We start, but soon find our carriages of little use: the road, or bank, on which we run is narrower than the vehicles, so they are carried, while we walk.

The kagos supplied to us at Kamuro-Mura may be thus described. Each has a circular disc of basket-work with a slightly raised rim suspended by four ropes from the centre of a pole of wood about twelve feet in length, six or eight inches deep, and three inches in thickness. Extending from the centre of this pole to the right and left is a little roof, while a board ascends as a back rest from the basket to the hindmost part of the canopy.

To take a seat in this vehicle is a much more difficult matter than might be supposed. The Japanese are chiefly small men; and through being accustomed to squat on the floor from earliest infancy their joints have a pliability unknown to ours. Hence my companions double themselves up into a sort of ball and appear perfectly happy. After many efforts my success is only partial. My feet will hang out, and I am obliged to get the coolies to form two stirrups of string to support my legs, and save them from being cut by the raised edge of my seat.

Three men are engaged to carry the burly foreigner, while two suffice for each of the other members of the party; thus one of mine is always resting while two are at work.

We now start on our march, a man bearing each end of the enormous pole, from the centre of which the scale-like contrivance depends with one of us seated in it. The men walk steadily and with firm step, stopping to rest about once every hundred yards; but when about to stop each man places under his end of the pole a strong stick which he carries for this purpose. At every stoppage one of my men is released, the spare coolie taking his place. Uncomfortable though I am, the air is so cold, and I am so tired from the exertions of the last few days, that I soon fall asleep. When we started in the kago we were ascending a high hill on the right bank of the river, and how the poor men carried me up I do not know. Yet they talked and laughed as though they were simply amusing themselves. When I awake in about half an hour the scene is simply wonderful. We are on a little

path skirting a mountain slope, and down some fifteen hundred feet beneath us, in a strange and most precipitous dell, nestles a little village wrapped in palm-trees and bamboos.

To the village in this hollow we descend, and here every house appears to be engaged in the manufacture of paper, for the boards on which it is dried lean against every wall.

We now begin the ascent of a much higher hill than that over which we have just passed. The path soon becomes so steep that I get out and walk. The peeps into the valleys deep down below us, the views of mountain peaks, which are here as numerous as the trees in a forest, and the river that we have repeatedly crossed winding its tortuous way through the centre of its vast stony bed, I shall never forget. Sometimes we look down between the trunks of trees into a defile that seems bottomless, while all around are cryptomerias of huge proportions.

We now gain the edge of another picturesque valley, at the other side of which is a village, which we reach by skirting a mountain and making but a slight descent. This is the village of Kamiya-tsuji, and as there are no hotels in the sacred city to which we are journeying, we should have been obliged to remain here for the night had not the governor of the province in his goodness despatched a policeman to give notice of our arrival, so that preparation might be made for our sojourn in the city. I now try my kago once again, but in less than fifteen minutes the ascent becomes perfectly fearful ; so I again alight, to the great joy of my coolies.

This mountain differs much from any that I have before seen, for, while it towers to a great height, it is most richly covered with immense timber trees to its very summit. Here are also great vine-like stems, rising from the ground to the lower branches of the trees, and then in a hundred festoons leaping from bow to bow,—a thoroughly tropical habit. I am told that this is the *Westeria-creeper* in its native abodes ; yet while in growth this plant is here thoroughly tropical, we are getting to ice and snow, which at this height cover the ground to a considerable thickness.

The snow gets more slippery, the path more steep, the ravines

deeper, till they surpass anything that I have before seen. Never have I looked down to such a depth between immense trunks of trees as I now do. The bottoms of valleys are many hundreds of feet below us, yet the mountain, with its rich plumous vegetation, towers far above. The path now becomes so steep that I can scarcely climb it; so a coolie, having straw sandals on his feet, pushes me from behind. My thirst is so great that I gladly fill my mouth with snow. More toil, more lovely views, more snow, and in the late twilight, with the crescent moon and a few stars of exceeding brightness above us, we reach the top.

On our left is a small temple, and on the right a Dai-butzu. For a thousand years, and until the revolution of ten years back, no woman had passed this spot. For ten centuries no female had entered the hallowed precincts of the sacred city, and but few foreigners have yet visited this most remarkable of all cities. I am the fifth Englishman that has set foot on this sacred soil, Sir Harry Parkes being one of the five.

We are now met by two more policemen,—a sergeant and a private (the one with us is a corporal),—and a priest, and, by the lights of lanterns, are conducted to a great Buddhist temple, where we are to lodge for the night.

It must not be supposed that in lodging in a temple we take up our abode in the sacred edifice itself. Around the building, or at its back, yet immediately connected with it, are arranged living-rooms, which are to the Buddhist priest what the parsonage-house is to an English clergyman.

The living rooms placed at our service are most charming. The ceilings are in square panels of plain, clean wood, and the woodwork of the walls is also without paint or varnish. The slides forming the partitions between adjacent rooms have landscapes drawn upon them in a beautiful, though conventional manner; heavy horizontal clouds cross the mountains, but these clouds are in solid gold, with a raised outline and diaper-work upon them, the diaper and the outline being rendered visible only through their surface being raised above that of the ground.

An excellent meal is now prepared, but no eggs, no fish, and

no meat may be sold on the mountain. One profane policeman has, however, brought with him ten eggs, of which he gives me four. Being exceedingly hungry, I eat without scruple, enjoying my meal, and drinking freely of the hot Japanese tea.

Although everything is so pure, so clean, and so thoroughly Japanese, European influence has, nevertheless, invaded the precincts of this city of temples, for in the late evening a common paraffin lamp of the ugliest form and commonest make was brought to me. I felt that the place was desecrated by this wretched specimen of Brumagem art; and apart from the question of taste, the danger of introducing paraffin into such an inflammable building as a Japanese house is very great.

I am in the town of Kōya-zan, a town consisting chiefly of temples, of which four hundred and forty now exist on the mountain, while formerly a thousand such buildings nestled amidst the rich foliage which here surrounds us. In the town there are one hundred and ninety-nine houses and shops not connected with the temples, and the population is one thousand and ninety-five, of whom three hundred and eighty-five are priests. Here is the largest university for the rearing of priests in Japan.

*February 18.*—By seven we are astir, and by eight have breakfasted, and are ready to see the temples. The morning is bitterly cold, and the night has been intensely so. Placed near my bed was the largest Hibachi that I have yet seen in Japan, and this contained a pile of glowing charcoal, such as I have never seen before in this country. Yet, when I awoke in the morning a towel, which I had spread beside it to dry, was frozen as stiff as buckram, while a bottle of water near my head was solid ice.

With the chief priest of the temple as guide, we started to see the town. Passing the little shops, where I purchased a few old and interesting things, and trudging through the snow, under the shadow of cryptomeria trees a hundred and fifty feet in height, we entered a vast grove where gigantic coniferous trees spanning the roadway and meeting together form one vast cathedral nave, under which monuments to ten thousand of the great dead find shelter.



This grove is magnificent beyond all description. Under the richest of foliage are arranged thousands of monuments, from ten to twenty feet in height. All the larger monuments are similar in form, and are made of the same number of stones. The top-most stone is of the form of an onion, the next of a cup, the third is square and has four ear-like corners, the fourth is a compressed sphere, the fifth a cube. Then comes the base, consisting of a lotus moulding, and a slab or plinth, on which the whole rests (Fig. 38). There are hundreds of these monuments at either side of the grove; and here and there a little shrine of superb architecture gives variety to the scene. These shrines are as richly ornamented and as elaborately coloured as the Alhambra at Granada.

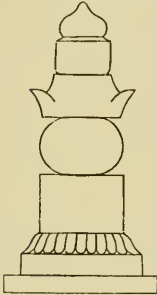

FIG. 38.—MONUMENT  
IN THE SACRED  
GROVE AT KOYA-  
ZAN.

All of these monuments and shrines have been erected by relatives or friends of deceased persons, and the larger structures commemorate almost exclusively great warriors. A little boy runs before the priest, and in a singing voice cries out the names of the chief celebrities to whom the monuments have been erected.

We saw the first monument here raised, it having being built during the lifetime of the founder of this grove, Kōbō-Daishi, who died A.D. 843.

As I see it the grove is very charming. On the ground is snow, several inches in depth; the sun is just peeping through the trees; white masses of the crystallised water, like so many spotless doves, keep falling from the branches high above us, while the thousands of monuments, and the richly coloured shrines, make up a scene altogether indescribable.

Traversing the grove for about a mile, and crossing one or two streams, which are spanned by bridges, we come to a temple directly facing us, and which, with its associated buildings, terminates the grove. This temple is the Toro-do. Into this temple we look, but are not permitted to enter.

About a hundred lamps are burning in it, and the priests are

engaged in melting the frozen oil over charcoal fires, in order to kindle more lamps, and replenish those already burning. As our eye becomes more accustomed to the dim light of the sacred edifice we see that it is filled with lanterns ; indeed, stands somewhat resembling those used at our railway stations for the lamps of the train are crowded together, and while each of these contains three layers of lamps, the stands are so numerous as almost entirely to fill the temple.

Our priest-guide now informs us that there are eight thousand of these lamps in the building, that on ordinary days about one hundred and fifty are kept burning, that on feast-days about fifteen hundred are lit, while on the 26th day of April—the anniversary of the death of the founder of the grove, and of that sect of Buddhists to which all the temples on this hill belong,—nearly the whole eight thousand are lit. The temple is black with smoke and greasy with oil. As we face the temple we see on our left a small piece of enclosed ground, containing a few plain mounds of earth with stone monuments of great simplicity crowning them. These are the monuments of Mikados, and it may here be noted, that while the Shôgun found his resting-place in a magnificent tomb, the grave of the Mikado was always a simple mound of earth ; but no one is buried in this grove, for it is not a cemetery. It is simply a vast collection of monuments raised to the illustrious dead.

Behind this temple, which is so rich in lanterns, is a small building almost hidden by trees. It is thatched, and built of wood, and has on its summit that onion-shaped ball which represents the soul, or spirit, of man. This is the shrine of the founder, who died one thousand and forty-four years prior to my visit, and here I see the poor coolies who dragged our jinrikishas from Wakayama to Kamuro-Mura performing their devotions. Although they had dragged us twenty-five miles, they follow us throughout the remainder of our journey (twelve miles) and climb this great mountain as though they were actually in need of exercise.

We now return through the grove, and, passing the shops, come to a pagoda of peculiar construction. Near it is a temple, differ-

ing widely from that at the end of the grove, for it is nearly new (it was built eighteen years since), is exceedingly clean, and is beautifully decorated. This is the Gokoo-Shio.

We now visit another temple near at hand, where we are received by three priests, who show us the treasures of the sacred edifice. These consist chiefly of swords, but there is a much prized manuscript by the founder of the grove, one thousand and fifty years old, and yet in excellent preservation, and a manuscript by a Mikado who reigned some centuries since. The name of the temple in which these rare antiquities are preserved is Kongoho-Zi.

Visiting a house containing a thousand gods, I bought two drawings of their favourite divinities, a piece of blessed rice cake, and two pieces of a kind of moss that is said never to die.

After continuing our round as long as time will permit, we return to our temple, and are not a little glad to find a meal prepared for us. Our host tells us that the sect of Buddhists to which this mountain belongs forbids its priests to marry, and also to eat beast, bird, fish, or eggs. Thus it is supposed that they neither create nor destroy life.

Upon thinking matters over, I am at a loss to understand where the four hundred and forty temples which are said to rest on this mountain-top are; I have seen some twenty or thirty, but the four hundred odd have not come within my observation. Through each vista in the wood I see, indeed, the roofs of buildings, and all of these, I am told, are temples. But in order to understand this mysterious city properly a sojourn of weeks would be necessary; and even then but little would be known of the innumerable shrines, monuments, and temples which make up Koya-Zan.

In the midst of fast-falling snow we start on our return journey. The priest brings us to the end of the buildings, and a policeman sees us to that Dai-butz which marks the entrance of the town. None of us enter our kagos, for the road is so steep and the path so slippery that we are afraid to be carried.

Soon my boots become as slippery as the ice-covered ground

on which I tread. Two coolies come to my help, and I manage to get on only by putting an arm round the neck of each.

Seeing that the Japanese can walk in safety in their straw sandals, I ask the coolies to tie a pair on my boot soles, as they have a stock in reserve ; but as no amount of tying secures them in this position I am forced to take off my boots and adopt the native shoe. I find that I can now walk with ease. So all goes well till we reach a warm hollow in which the snow is melting. Here the discomfort reaches its acme, as I might as well be wading through iced water with naked feet as walking in sludge with simple sandals on.

We continue our journey along the winding path and down such descents as I never remember seeing, even in Switzerland. We wear neither topcoat nor hat, sheltering ourselves from the snow with a native umbrella, yet we are almost melting with heat. Never did I see effects more weird and grand than those which are now before us. Trees bending over with snow, palm-trees presenting the strangest of aspects, bamboos like huge white ostrich feathers ; while down yonder, far beneath us, is a dimly-drawn distance which might belong to another world, as it has no features familiar to us in this.

We journey on, and it becomes dark. The evening is bitterly cold, hence we are not sorry to reach the little town where the night is to be spent and to have a meal, though it consists of eggs as usual. The little hotel in which we are lodged is clean and comfortable, and it certainly is well ventilated, for around the top of my room there is an open-work frieze of eight inches in depth communicating directly with the open air. Snow and ice without and no fire within, while the wind courses through the chamber just as it pleases, do not add to comfort ; yet, wrapped in my dressing-gown and my rug, I sleep soundly and suffer no harm from the cold.

We have a long day before us, so we rise early and by seven are on our road. My boots are so damp that it is impossible to get them on, hence I resolve to try Japanese socks and sandals, and to keep my feet dry and well wrapped in fur ; but how vain

are man's hopes! We have not got two miles on the road when the path becomes narrower than the vehicle; hence I have to trudge through the snow, while the jinrikisha is carried. Our road lies along a path, skirting a river often forty to sixty feet below us. Reeds at the side of this elevated path look like solid ground, and in many parts the path is but little broader than the jinrikisha. Throughout the whole of this portion of our ride there is constant excitement, for the danger of our slipping over the precipice is not slight, and once I was saved only by making a sudden lurch in the opposite direction, while my men gave a sudden bounce.

A cold bath is not pleasant at this season of the year, and it is likely to be peculiarly distasteful when the carriage accompanies you in your descent, and the water which you reach in forty feet is but one foot deep.

The road gets better, but the snow gets thicker; still by eleven o'clock half our journey is over. The snow ceases to fall, the sun shines fitfully, and then come showers of cutting hail. The snow becomes sludgy, then less in quantity, and we find Sakai, the town for which we had been making, with streets as dry as if it were an August day.

We now go to the Government House—a building of great beauty, and formerly a temple—and see samples of the manufactures of the province, which have been collected here for my inspection. There are cotton fabrics, silk crapes, earthen vessels, glass beads (the glass in a crude state, being imported from Europe), with other things, but nothing that strikes me as specially suited to European wants.

Bidding adieu to the governor, we visit first the chief carpet manufactory, a very small establishment, in which weaving is carried on in the most simple and rude manner; then the cutlery shops which here abound—for Sakai is the seat of the steel manufactures of Japan,—and afterwards a pottery, where only coarse wares are made.

We were just going to take our seats in our jinrikishas, when Mr. Sakata, whom we had missed for some time past, came in

excitedly with the news that a revolution had broken out in Satsuma, and that an army was on its way thither to quell the rebellion.<sup>1</sup> Sakata himself is from the south. We start, however, for Osaka, and after a pleasant run reach our old hotel, where I am glad to find a comfortable European bed awaiting me.

The next two days are spent in Osaka, with the exception of a few hours devoted to visiting a pottery near Hiogo, where Kishiu ware is made. We now learn that the insurrection has spread to several provinces, and Mr. Saumarez writes from Tokio to say that it may be serious, as most of the army consists of Satsuma men.

The weather now presents a striking contrast with that of two days since, for it is gloriously fine, and as warm as spring. Yonder, however, in the distance are the snow-clad mountains, and I fear that were we on the higher ground, we should still find winter in all its severity. Upon our return from Kobe, after visiting the pottery, we found that to leave the railway station at Osaka we had to pass between two rows of policemen. A little excitement was caused by one of our party being seized, but after explanation he was allowed to join us again,—the fact is, he was accused of being a Satsuma man, and all the natives of this province unless in Government employ, being regarded as insurgents, are cast into prison till tranquillity is restored.

It is a feast-day of one of the gods of riches :—the god Yebisu is receiving homage, and both here, at stations on the road, and at Kobe, hundreds of people are out in holiday attire worshipping

<sup>1</sup> This rebellion ultimately became very serious, and it materially circumscribed my route in Japan. The rebellion of 1868 A.D. which ended in the overthrow of the Shôgun and the restoration of the Mikado, was headed by General Saigo, who, being victorious, was ultimately made the Commander-in-Chief of the Mikado's troops. This General Saigo had a younger brother who also became a general in the royal army, and it is this brother of whom I have so often spoken at the commencement of this work. The senior Saigo has now himself become the arch-rebel, and is warring against the powers which he himself set up. The younger brother has recently been made Commander-in-chief of the royal troops, hence we have the strange spectacle of two brothers heading contending armies. After months of warfare the rebellion was ended by the Royalists proving victorious, and the rebel chief committing hara-kiri. The younger brother is now the Japanese Minister of War, but those who are interested in this matter should read that admirable book, *The Satsuma Rebellion*, by Mounsey.

their god. Yebisu is one of the seven gods of plenty. He sits with one leg up and one down, is always laughing, has a fish (the red *tai*) under his left arm, and is fond of *sachi*.

Near the temples where this god is worshipped are numerous stalls, where you may purchase on his feast-day, toy fishes of red colour and *sachi* tubs. This god and another, Daikoku, seem always associated, and they may both be purchased in the form of small images. Charms are sold on this feast day, each bundle of which contains a piece of gold paper (supposed to be an old gold coin), a model ingot of silver, bags for money, a large bag for ingots, a bag of rice, an account-book, a hammer (the hammer of the god Daikoku), a key of a warehouse, a measure of quantity, a pair of scales, and ribbon-like streamers. This bunch secures good luck to the possessor, and in its simplest form may be procured for one halfpenny.

The seven gods of riches are, Yebisu<sup>1</sup> whom I have already described ;—Daikoku, who sits on two rice bags, holds a hammer in one hand, and is also always laughing ; if this god strikes with his hammer money appears wherever the blow falls ;—Hotei, who has a very large stomach, large ears, and who sits beside a very large bag containing valuable things ;—Jiurō, who has a very high forehead, is very old, has a long beard, holds a staff in his hand (generally a deer is represented as following this god), and gets riches through his wisdom ;—Ben-ten, a goddess, who has a musical instrument and snakes following her ;—Bishiamon, who wears armour and gets rich by conquest, has a spear, and bears a small pagoda in his left hand ; and Fukuroku, who wears a cap resembling that of our brewers' men, with the top falling over, and has a beard, but I cannot learn how this gentleman acquires his wealth. The first three and the female appear to be known to every one in Japan ; but the latter three are not well known.

Osaka is rich in temples, some of which are most elaborately and beautifully carved. One pagoda and temple are worthy of special note, as even the under surfaces of the over-hanging roofs are most richly modelled and coloured. But a description of the

<sup>1</sup> If any one laughs inordinately it is said that he laughs like Yebisu.

numerous temples of this city could only appear monotonous, beautiful though some of them are. In one that we visit chanting is going on and music which reminds me of an English pleasure fair. Here in a belfry is a priest with two thick shavings of wood in his hand, each being beautifully cut, and about ten inches in length by one inch and a half in breadth; on each is written the name of a dead child. Behind the priest are two women joining in the chant, and it is they who have lost their infant children.

Around the interior of this belfry runs a small gallery, the lattice railing of which is literally covered with the belongings of children—frocks, hats, sandals, dolls, etc., and on the floor of the edifice are many similar things. These have all belonged to children now dead, and have been brought by the mothers to this sacred spot. The chant being over, the priest strikes the great bell three times with a heavy rope which dangles by its side and causes it to give forth its grand booming sound. He then gives the shavings to the mothers, one to each. These shavings the women take to a sunken tank situated in the bottom of a pit some twelve feet long by eight in width, into which water is always running. The tank is filled from the mouth of a tortoise which seems to be climbing over its edge. Into this running water the women introduce these shavings by placing them in ladles with cylindrical bamboo bowls and handles of great length. When once these shavings are free and are immersed in the water, the mothers seem perfectly satisfied; they watch them with the utmost complacency for a few brief moments and return home happy, having, as they think, done all that they can for the little departed ones.

There is a particular kind of gateway called *torii*, which stands in front of all Shinto, and many Buddhist, temples, which consists of two uprights, a cross-piece on the top, and a tie-beam. Here at Osaka there are hundreds in the grounds of one temple (Fig. 39). They are all painted red, as the temple is dedicated to the Fox, and arranged in groups without order. In one group I counted a hundred of these curious structures. From this temple, which, like so many in Japan, is on high ground, a view



of the town, surrounding country, and bay can be got, which, under the effects of sunset as I saw it, was most splendid and charming.

At 8.30 we leave for Kyoto, where we find two long rows of policemen guarding the exit from the railway station, each with

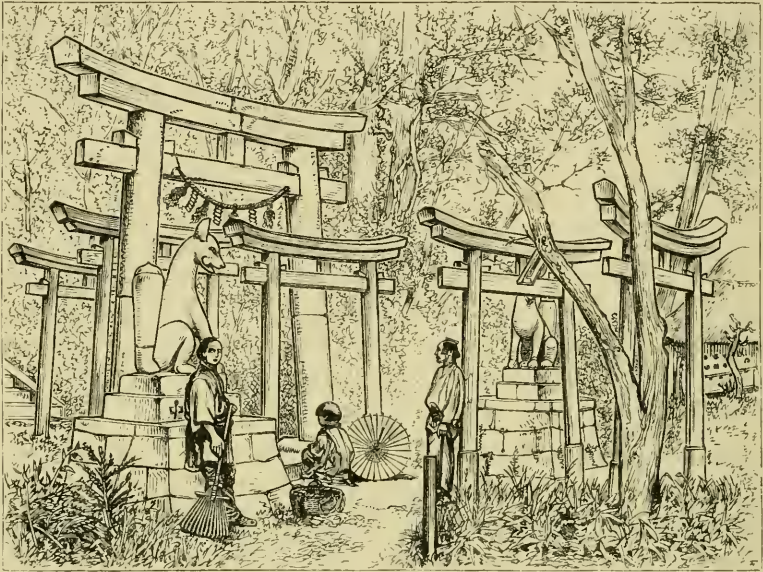

FIG. 39.—TEMPLE IN OSAKA. Showing a few of the Torii in the Temple Grounds. Here the Fox is worshipped as the God of Agriculture.

a paper lantern. The first one, reading from a scroll of paper, calls each of my escort by name. The Governor of Osaka has communicated our coming lest any of the party should be arrested as Satsuma men.

I now begin to wonder whether I have been exposed to danger during my journeyings, and whether the police escort which has accompanied us from town to town has been needed for our safety. Thus far I had looked on them as rather an obtrusive adjunct to the party, but after all it may be regard for my safety which has induced the authorities to act as they have done. I take up my quarters at a tea-house called Nakamura, on the plain, thus saving the fatiguing ascent to the Mariyama hotel on the hill.

## CHAPTER VI.

Temple of Kioto—Japanese estimate of Christianity—Picnics—Honest workmanship—Lacquer-work—Value of Corean ware—Tea-drinking ceremony—Otsu—Futami-gaura—Kamiji-yama.

To see the Kioto temples in the most cursory manner ten days at least, I am told, would be needed. We first visit a temple called Kiyomidsu, beautifully situated above the Mariyama hotel. It is one of the thirty-three temples of which we have already spoken. Leaving the temple, we proceed along the hill to a Buddhist cemetery—Nishi-otani. All the tombs, which are very closely packed together, are pyramids of stones, the only variation in any being that the top stone of the pile is sometimes a mere cube with a domed top, sometimes a cube with a square mushroom-like cap, and sometimes a cube with panelled sides.

I am told that poor persons when dead are placed in a box in a sitting posture, and are carried to the grave in a kago, while the rich lie in a coffin and are dragged in a kind of horse-car. A person here in Japan can be buried wherever he pleases—in a field, by a roadside, or under a tree; all that is needed being that he purchase the ground for his sepulture. A site commanding a lovely prospect is generally preferred.

We now come to the gateway of Otani, a beautiful object, and thence to a temple in which is the head and shoulders of an enormous Dai-butzu, formed of planks of wood. These planks are covered with gold paper, but as every join in the wood is visible, the whole effect is so coarse as to be almost horrid.

After this we saw the Corean "ear monument" (Fig. 40), which in form almost exactly resembles the monuments of Koyazan. When the Japanese went to battle in former days, it was customary for them to bring back the heads of the slain as trophies; it was, however, found too great a task to bring back the heads of those slain at the conquest of Corea, hence the ears only were secured as trophies. After these had been exhibited in Japan, they were buried in a mound, on the top of which this monument stands.

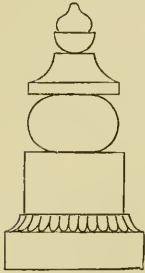

FIG. 40. — COREAN  
"EAR MONU-  
MENT."

Next we see the Sanji-sanken-do or temple of thirty-three divisions. This temple is one hundred and two yards in length, is divided into thirty-three spaces by pillars, hence its name, and is absolutely filled with life-size figures. It is popularly believed that there are in this temple thirty-three thousand three hundred and thirty-three idols, but in reality there are only a thousand and one. Some of the idols, however, have forty hands; others have nimbi on which small figures occur, and some are sheltered by canopies crowded with little deities. Hence it is supposed, although erroneously, that the larger number is reached.

These figures are arranged in straight rows on a gradually rising gallery, and all face one of the long sides of the temple. These lines are, however, broken in the centre by a Dai-butzu, and twenty-eight figures, which are of special interest, as they are a thousand years old, and were brought from Nara. In front of these stands an idol with a nimbus and a vesica piscis on which are a thousand small gods, each with a nimbus. There is also a popular belief that the ridge of this temple-roof is formed of one piece of wood (willow), and that the whole of the idols contained in it, save those from Nara, were made from branches of the same tree.

We now saw the largest pagoda in Japan, the Tōzi-no-to, or that connected with the temple of Toki. It is of splendid proportions, but is without any of that rich carving which we observed on the pagoda at Osaka.

At the temple of Tōzi we see people, both old and young, with slips of split bamboo on which the name of the temple is written, running round one of the temple buildings, and throwing

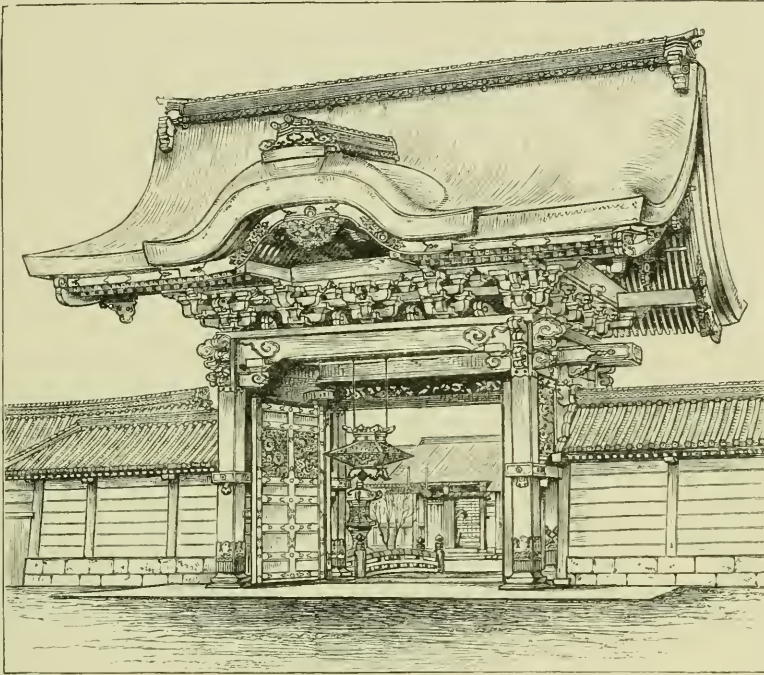

FIG. 41.—EAST GATEWAY OF THE TEMPLE, NISHI-HONGWAN-JI, KIOTO.

a stick in a box each time they get round to it. I understand that this is considered to confer some religious advantage upon the performers.

The gateways of the temple Nishi-hongwan-ji are as beautiful as the temple to which they lead, and that is saying much (Figs. 41, 42, 43, and 44). Here we are received by a priest who speaks English well, and who shows us through the main building, the many rooms connected with the temple, the garden, and a house in which a peculiar "tea ceremony" takes place.

From the priest I learnt a fact of peculiar interest. After the revolution of 1868 the newly-formed Government adopted, to a certain extent, both European manners and customs, and set

itself to establish manufactures on a European basis. Filled with a desire to utilise for their own good the experiences of other

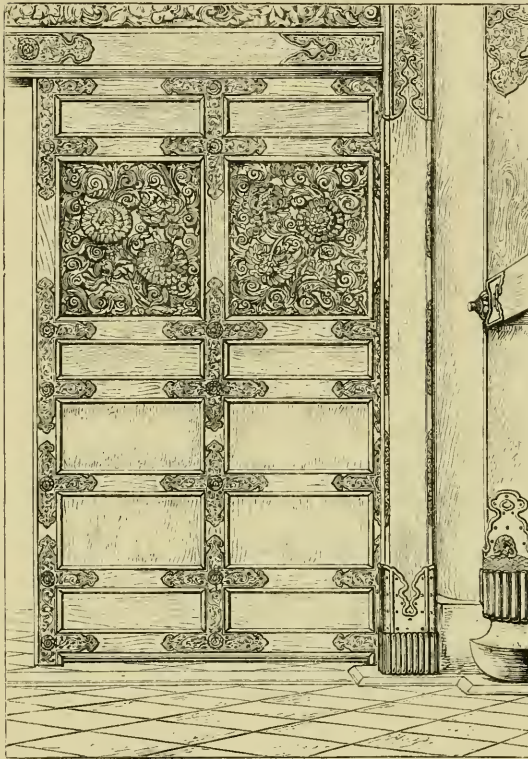

FIG. 42.—DOOR, OR GATE, IN THE EAST GATEWAY OF THE TEMPLE, NISHI-HONGWAN-JI, KIOTO.

nations, they seriously considered whether European progress was not traceable to the influence of the Christian religion upon the people, and whether they should not adopt the Christian faith, together with a European civilisation. With the view of studying Christianity and reporting on it, the high priest of Nishi-hongwan-ji, and priest Akamatz, who has been our guide around this beautiful edifice, were sent to England; and with that object remained in London for eighteen months.

In sending these particular priests the Government had a motive, for they belong to the most spiritual of all the Buddhist sects,—a sect which has no idols, and allows the priests to marry; but after their sojourn in London they reported that as a civilising agent Christianity was inferior to the religion which they themselves professed, and that in our Christian country crime, vice, and drunkenness were much more common than in their country, where Shinto and Buddhism prevails.

The next temple that we visit, that of Chion-in, is a magnificent structure, built by the most celebrated carpenter (builder)

that Japan ever knew, and a man who is idolised by the craft of

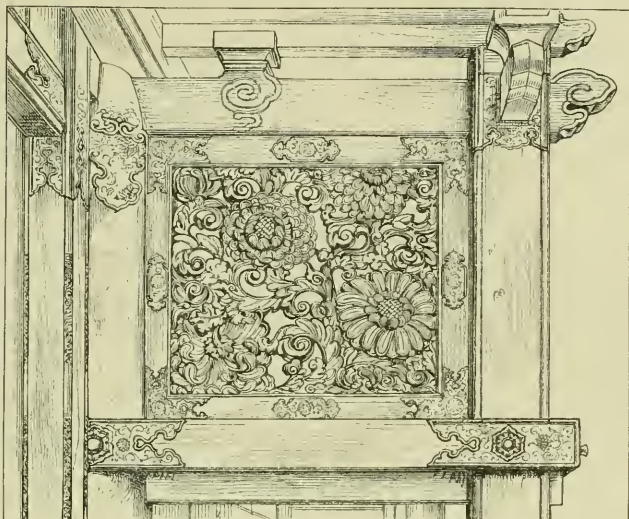

FIG. 43.—CARVED PANEL IN EAST GATEWAY OF THE TEMPLE, NISHI-HONGWAN-JI, KIOTO.

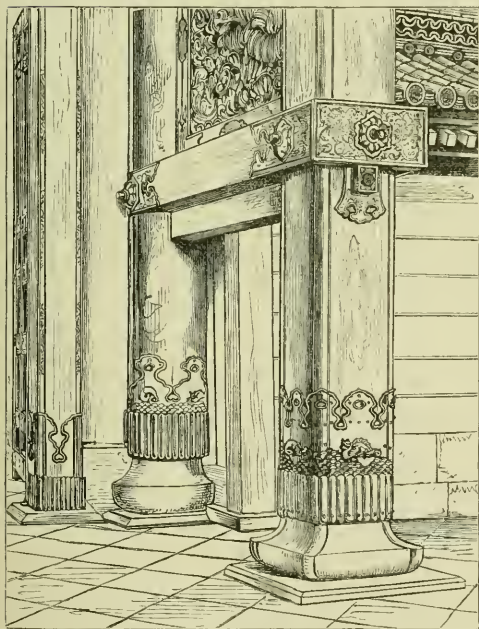

FIG. 44.—DETAILS OF EAST GATEWAY OF THE TEMPLE, NISHI-HONGWAN-JI, KIOTO.

the present day. The attention of the visitor is here directed to a portion of an umbrella which is visible in the roof. This was the umbrella of the carpenter-builder, and it is said that he left it there, in order that a part of his belongings, as well as his work, should remain to posterity.

In a building connected with this temple is the largest bell in Japan. It is nine and a half feet in diameter at the mouth, eleven inches thick at the rim, and sixteen feet in height.

The other temples which we visited are of less interest than those already seen, and there is a sameness about them which renders any description unnecessary ; but during our rambles we see several with the yellow walls and five white lines, which indicate that the high priest of the temple is of royal blood (Fig. 45).

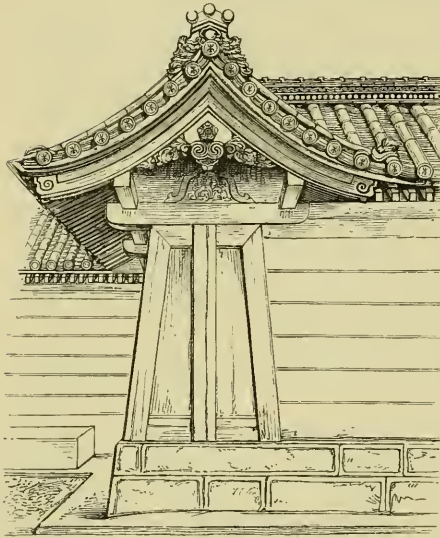

FIG. 45.—WALL IN KIOTO. The five parallel white lines indicate that the building belongs to a person of royal blood.

Here I may notice, that none of the children of the Mikado, save the eldest, who is to succeed to the throne, can marry ; the boys must be priests and the girls nuns.

My Japanese companions now arranged that I should see in the large room of the hotel a dance peculiar to Kioto, in which the costumes are those of the characters personated. To me this dance is strange rather than beautiful, and I am not sufficiently familiar with the characters represented to catch the meaning of the

representations. This combination of dancing and acting, in which the motions are slow, gentle, and graceful, had its origin seven hundred years back, and is much appreciated by the Japanese.

The weather is now so warm that people are beginning to talk of picnics ; but unfortunately the picnic season has not yet arrived. The favourite excursion for the merry-making people of Kioto, during the time of the cherry blossoming, is to Arashiyama, a hill famous for its cherry-trees. As at Killarney you buy objects of arbutus wood, and at Jerusalem trinkets formed of olive stems, so at Kioto you buy boxes formed of cherry wood. Each of these objects is inscribed with the name of the hill on which the cherry-tree has grown.

Picnicing is much enjoyed by the Japanese, and some of their richest art and most careful workmanship is expended in the production of cases, boxes, and various contrivances, in which they carry their picnic to the country. Some of these contain vessels of the most minutely figured lacquer-work, bottles formed of silver inlaid with golden sprays, and sachi cups perfectly delicious in character.

On the ninth day of January (old Calendar) the Japanese go out and gather seven kinds of grass, taking their picnic with them; each person carries his own picnic-case, while most have a separate supply of sachi in a bottle-gourd slung over the shoulder on a hedge stick. The grasses are taken home, boiled, mixed with rice, and eaten as a salad.

I have already engaged the best photographer in Kioto to make photographs of architectural details and rare objects, and I now engage the best decorative artist in the city to make coloured drawings of temple decorations as I am anxious to get all the examples of true Japanese art that I can.<sup>1</sup>

The next days we spent in visiting potters, metal-workers, and manufacturers, and in searching the curio shops for treasures; but on the 28th we arranged to visit certain celebrated temples ten miles distant from our present home. On our road we called first at a Shinto temple, which has a huge dragon in full relief pendent from the ceiling of its band stand;<sup>2</sup> next at a temple where there is a covered bridge resembling those at Lucerne<sup>3</sup> (Fig. 46). Here in the main building (Butsu-den) are three figures, the central being a Dai-butz sitting on a lily. The figure, measuring fifty feet in height without the base, has a nimbus, and a vesica piscis of vast dimensions. Both the temples and the gods are six hundred years old. Next we see a Buddhist temple at Uji<sup>4</sup> (Fig. 47) founded by a priest who came from Ingen,

<sup>1</sup> Accompanying the drawings which I ultimately received from this latter artist was a coloured model of a complicated bracket of which I wished to have a drawing. To my question why this model was made, the answer came that—owing to his imperfect knowledge of perspective he could not draw this elaborate work, and that he had consequently made a model instead (see Fig. 72).

<sup>2</sup> This is the temple Takinoo-no-yashiro.

<sup>3</sup> This is Hodo of Tōfuku-ji (Fig. 46).

<sup>4</sup> This is Ōbakuzan Manpuku-ji.



in the district of Annan (now Saigon), and who brought over forty of the columns with him. In the courtyard of this temple are immense stacks of blocks, used for printing the Buddhist scriptures; they are tied together in bundles of ten, and there must be many thousands of them.

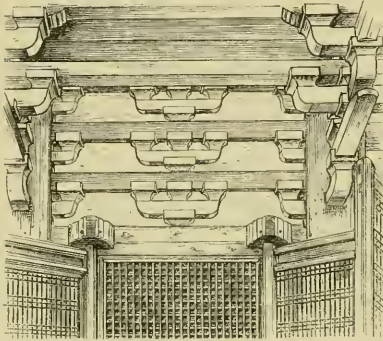

FIG. 46.—WALL OF THE TEMPLE TOFUKU-JI, KIOTO. Formed of wood, with bracketed structure, and plaster.

Crossing a river which flows from Biwa Lake, and the surroundings of which are highly picturesque, we enter a charming tea-house in which the empress stayed a week or two since, when on her way to Kioto from Nara. We are now at the village of Uji,

on the highroad from Nara to Kioto, and the tea-house where we rest is the Kiku-ya (Kiku = Chrysanthemum; Ya = house). At Uji the best tea in Japan is grown (Fig. 48 gives part of a tea-making establishment), and nearly every house here is engaged in the tea industry. Here also are sold netsukies, tea scoops, and other trifles, formed of the hard and close-

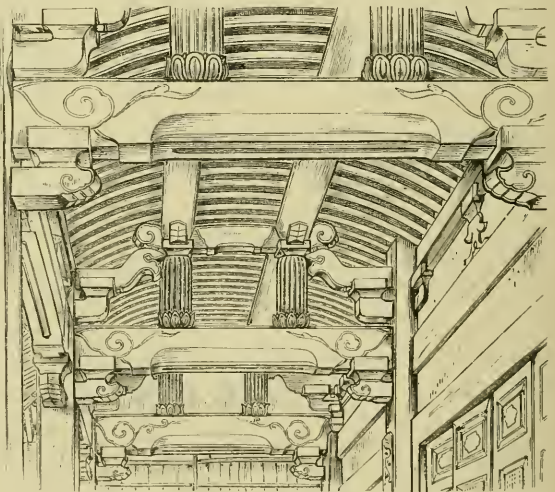

FIG. 47.—INTERIOR OF ROOF OF OBAKU TEMPLE.

grained wood of the tea plant. As art works there is little merit in these productions, for they are made to gratify excursionists rather than to please true lovers of art.

After luncheon we go to see one more temple which stands on piles, or supports, rising out of water. At the first glance it appears Indian in style, but upon closer observation its constructive

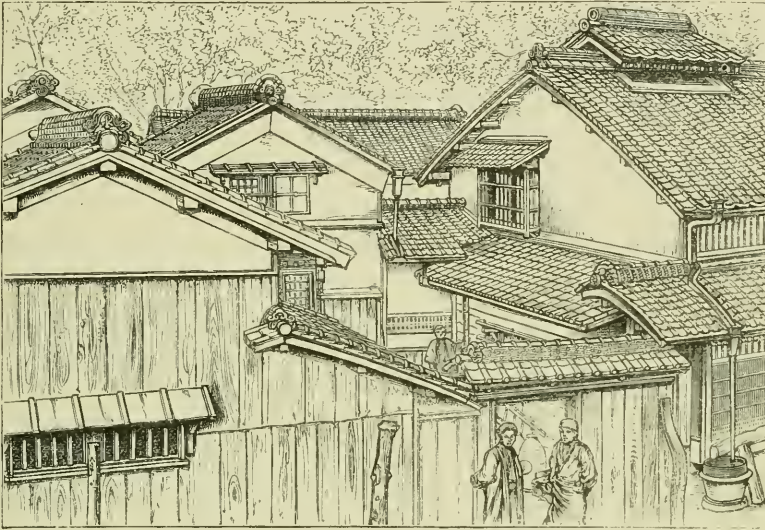

FIG. 48.—TEA MANUFACTORY AT UJI, NEAR KIOTO.

details are all seen to be Japanese. This temple is no longer used, and neglect and decay are doing their terrible work. This is the more to be regretted as it has been one of the most splendid temples in Japan. The key which the priest brings to open the building for our inspection is so remarkable as to deserve description. Its handle is a rod of wood an inch and a half in diameter and two feet in length, while the lower portion is a mere bent piece of iron about half an inch square. This key is inserted through a hole in the door of about two inches in diameter, the bent metal portion being introduced first and then a portion of the handle. The priest now feels about with this colossal key till he has found a slot in a large wooden bolt ; this being caught the bolt is thrown up by an effort and the door opened (Fig. 49).

This temple is eight hundred and eighteen years old, and most of the internal decorations which remain are as pure in style

as the ornament found on the old felts at Nara, and are Indian in character. The building must have been of extraordinary beauty when first erected, for all the structural members of the roof are elaborately inlaid with pearl, and a piece which has dropped from

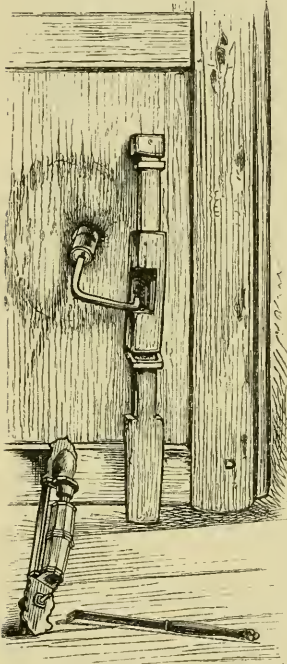

FIG. 49.—INSIDE OF ENTRANCE-DOOR OF ISURIDONS, UJI, NEAR KIOTO. The end of the key is seen protruding through the door and feeling for the slot in the bolt. Leaning on the floor and the bottom bar of the door is a padlock; its key being on the floor.

the ceiling shows that the inlaying has been of a most finished character. Between the structural members the ceiling is painted with flat ornament, rich in design and beautiful in colour, while a stand on which a *Dai-butzu* rests is as elaborately inlaid as if it were intended for the most minute inspection. This temple is the *Hōwō-do* (*hōwō* = peacock and peahen; *do* = house). It is an interesting fact that in these great temples the work is all of the most honest and exquisite description. Whether seen from a distance or near it is all equally well finished, and even those parts of a temple which are never seen are as carefully treated as those which are always visible.

Upon my return to Kioto I find an elaborate English dinner prepared at the hotel where I am staying and that I am the guest of *Ju-Goi Kawase Hideharu*; but *Shiō-Rokui Makimura Masanao*, the Governor of Kioto, and two other officials are also present, as well as my Japanese friends *Ishida* and *Sakata*.

*Ju-Goi* is a title conferred by the Mikado, and Mr. Kawase is the "large secretary" of the interior department as well as the head of the board of commerce. He is here in Kioto with the Mikado and his ministers, but will leave in a day or two for Nagasaki. Mr. Machida, who opened for us the treasury at Nara, is also a *Ju-Goi* (*Ju* = wise; *Goi* = fifth) and is a large secretary of the interior department, as well as head of the imperial museum.

Both of these gentlemen are under Mr. Okubo, the minister of the interior, who is a Ju-Sanmi (Ju = wise ; Sanmi = third) and a "first-class" officer ; while the two other gentlemen, as well as the Governor of Kioto, are each "fourth-class" officers.

Secretaries in Government departments are ranked as large secretary, sub-large secretary, small secretary, and sub-small secretary. We have a pleasant evening and a long chat on the commerce and industries of Japan.

In the morning the chief manufacturers of Kioto meet at the "House of Commerce," where I am received by the Governor and Mr. Kawase. After some time spent in considering the works offered for my inspection by the manufacturers, I was welcomed to an elaborate luncheon. This over, I examined the works of several artists, certain kinds of lacquer ware, sachi cups formed of orange rinds, and many fabrics ; and in a building close by I saw looms weaving figured silks, rich damasks, and cloths of various descriptions.

Here on the top of each native loom a boy is perched, who is the prototype of our "Jacquard apparatus," and who, gathering together threads, raises them so that the weaver, by passing the shuttle beneath them, gives figure to the fabric. Up to the time of Jacquard we employed the same method of giving pattern to our fabrics that I here see before me, and the lad who thus controlled the pattern was called the "draw boy." This method of weaving, it must be remembered, is in advance of the more primitive way of working each weft thread across the warp by dipping it under or passing it over certain threads as necessary.

By the agency of the "draw boy" Japan is producing in the looms which I now inspect some of the most artistic fabrics that the world makes ; and were it not that the Lyons weavers can imitate some of these fabrics when once they have the pattern before them, and produce them at a much lower price than the Japanese can, those now being woven would be highly saleable in European countries. There is, however, another drawback to these beautiful fabrics of Japan becoming popular in Europe, for while most of them contain gold the thread with which it is woven

is far from durable, as it is a strip of gilt paper, and not a string of metal. This want of durability has created a prejudice against these Japanese fabrics which it will take a little time to overcome.

Side by side with the primitive looms which we have just noticed I see the finest of French machinery producing silk brocades, and the newest of card-stamping machines for supplying the jacquard of this newest of looms with its cards; but curiously, the silks woven by the new French machinery bear patterns of a bad European style, such as could not now be shown in our markets; while those produced in the native looms are highly artistic.

At five o'clock I bid adieu to Mr. Kawase and Mr. Makimura, but before doing so, promise to meet the former at the Mikado's museum at nine o'clock to-morrow morning.

Close by the House of Commerce are a number of covered booths and a large hall, in which specimens of the manufactures of the district are arranged, with the name of the maker of each specimen attached. To me, as a stranger, this display is of the highest possible interest, and here I soon discover objects unknown to European commerce. Here I see for the first time a specimen of Japanese translucent enamel. This beautiful ware is now common in our markets; but its introduction was due to my bringing with me the specimen which I saw here displayed with the other manufactures of Kioto.

To me the idea of collecting together all the manufactures of a district, and attaching to each specimen the name of the maker, seems one which might well be adopted in England. Surely business might be increased by the foreign merchant seeing specimens of all our manufactures, and learning where he could get whatever he needed, without the long and laborious process of visiting all the manufactories in a district. A hall of this kind might be provided in Manchester, Birmingham, Sheffield, Bradford, Stoke-upon-Trent, and other large manufacturing towns; while in London a central hall might be arranged for the display of the chief manufactures of the country. Here merchants and shippers would see at a glance where the particular wares which

they sought could be obtained ; and if neither the State nor the Municipality would bear the cost of the necessary buildings, a trifling rental for space would suffice to meet all necessary charges.

With the display of the manufactures of Kioto I am much pleased, and from it I gather an amount of information, which, but for the collective exhibition it would take weeks to accumulate. That it does the district good is certain. On translucent enamels alone, some thousands of pounds of European money have been spent in Japan, which would not have gone there had I not seen the one specimen amidst the articles of Kioto manufacture.

There is another curious fact connected with the open air part of this display. Here are boards bearing addresses printed in large letters. The people are requested to produce excellent works, as the position of a nation is greatly dependent upon the character of its manufactures, and upon the nature of the work produced by each of its handicraftsmen.

In the evening I noticed fires in beacon-pans, arranged outside a Shinto temple, of which it is the feast-day ; and I was told that this practice of burning fire is an ancient one.

The next morning I go to the museum to meet Mr. Kawase ; but the Governor of Kioto is also there to receive us. The museum is not a place open to the public, but a royal palace containing a large collection of antiquities belonging to the Mikado, and prepared for his inspection, as he is now here on a visit. In interest the objects here collected are second only to those preserved at Nara. I have thus the opportunity of inspecting and handling a second large collection of Japanese antiquities, such as even the natives themselves do not know. It is intended, however, to exhibit these treasures to the public at some future time, and a building is now being prepared for their reception.

In this collection, nothing pleases me more than the various specimens of lacquer-work, as these illustrate the state of the manufacture in various ages, and bear authentic dates. The curator of the collection tells me that the finest gold lacquer, as regards workmanship, was made during a period of two hundred

years, beginning about three centuries since ; but that the most artistic work was done prior to this time. In olden times the lacquer-worker and the artist were separate individuals—the lacquer-worker making the box, or tray, or bowl, and giving to it its beautiful surface, while the artist painted upon it such decoration as might be required. At this period the drawing was “touchy” and clever, but lacked that finish which characterises the best work of later times. About three hundred years ago, however, the artist and the lacquer-worker became one, and then was produced work of the highest mechanical excellence.

Ranged side by side, we have specimens of lacquer-work over five hundred years old, which are of a peculiarly artistic and interesting character, others four hundred, others three hundred, and specimens made only immediately before the revolution in 1868. Those that are five hundred years old, or more, are chiefly works with black grounds, and low-toned polychromatic ornaments in dull red, burnt sienna, raw sienna, and sage green colours ; and with a “broken” gold outline.

After carefully considering these works for some time I find it possible readily to distinguish between lacquer-work of certain great periods. Thus that which we may call modern (being less than one hundred years old) is easily distinguishable from that belonging to the middle period (which ranged from one to three hundred years since), while this again is separated by obvious characteristics from that which is older ; and even between that made four hundred years back and that of five hundred years since there is a manifest difference.

In this collection there is a specimen of what is called vellum lacquer—a lacquer having the colour of parchment ;—but the art of producing this particular lacquer has long been lost. I also hear that a violet lacquer was once produced in Japan, but that the secret of its manufacture is now unknown.

Since my return from Japan I have given much thought to the lacquer industries, and I have been enabled to send out material which has again brought about the production of purple lacquer ; thus a lost art has been revived.

Here are fine specimens of an object which closely resembles in character the "monstrance" of the Roman Catholic Church (Figs. 50 and 51). One of these contains the tooth of a bishop,

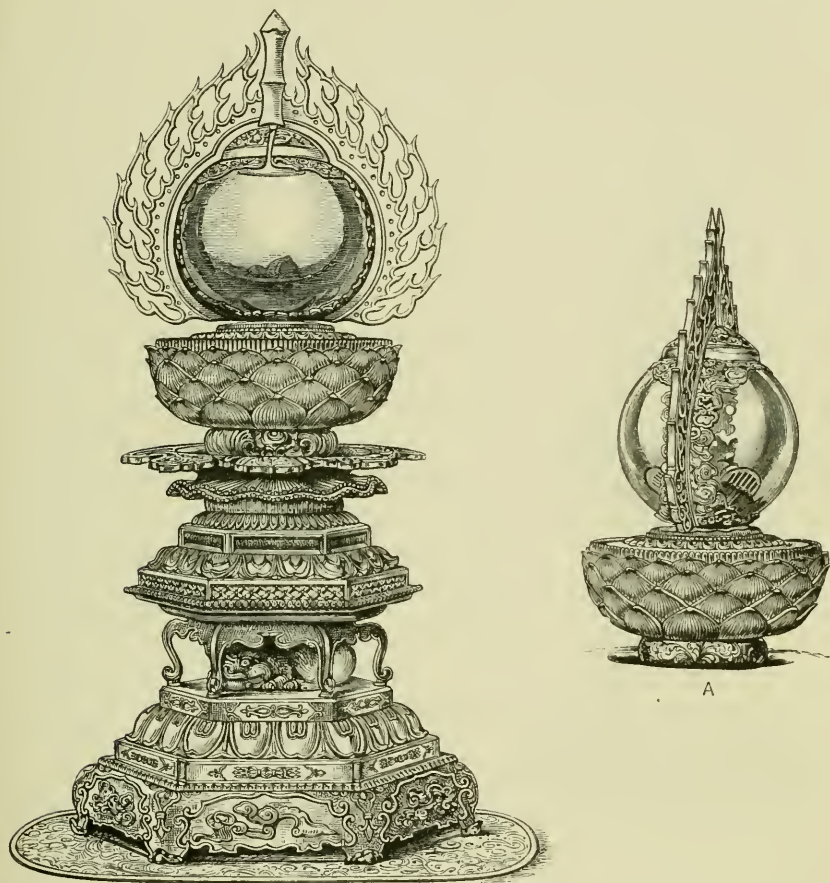

FIG. 50.—BUDDHIST MONSTRANCE. This was presented to a temple in Japan by Prince Mamayado, the son of a Chinese emperor, in the year A.D. 622. The name Mamayado means "door of a stable," as this prince was born in a stable. A shows the side view of the upper part.

while in another are small metallic lumps found in the ashes of a cremated priest. The superstitious believe that if the man has been wise there will be many such lumps found when his body is burnt, and if not that there will be but few. The monstrance is in some cases formed almost entirely of gold, and is of exquisite



design and workmanship (and of these gold objects there are fine specimens in the museum), and their parts have a symbolical significance from which much may be learned ; but of this I shall treat hereafter.

Here is an ink slab resting on a massive stand of pale blue glass which I am assured is of Japanese manufacture and is one hundred years old ; but the most interesting part of the collection is found in a small room, where dresses, a rude crown, a pair of top-boots formed of felt, and a few other things, which were brought by the great General Taikō from Corea, when he re-conquered that country about three hundred years since, are collected.

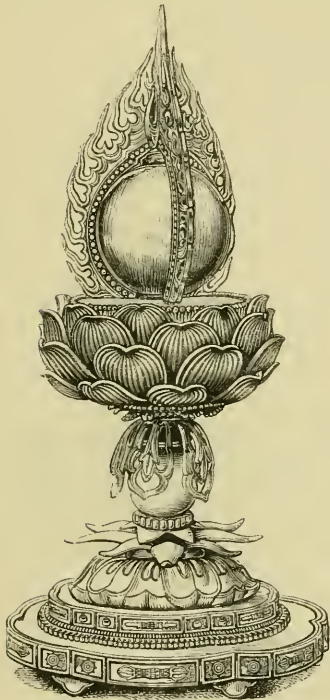

FIG. 51.—BUDDHIST MONSTRANCE.

Of dresses there are in this collection about twelve, some of which are formed of brocaded silk, while others are made of embroidered materials. One or two of these I should certainly regard as Chinese, while one is of a character which I have hitherto regarded as purely Japanese, the fabric being hard and appearing to consist of parts joined together. The pattern on this latter dress is large and bold, and consists chiefly of dragons and clouds. Whether these dresses were manufactured in Corea we do not know ; but under any circumstances they are of great interest ; and it is certain that Japan received many of its manufactures from Corea, while some Japanese are of opinion that the Coreans also furnished the Chinese with most of their arts. There are boots formed of felt, as I have just said, and several squares of figured felt, such as I saw at Nara. One of the dresses has gold threads woven into it, like many modern Japanese fabrics, and this gold consists of gilt paper, while the pattern is of scrolls

and anhemions such as now form the "figure" of many native fabrics.

From this collection I went to see the process of printing crapes, and with what I saw was much interested; but as I shall have to describe this process hereafter, I can only now mention the fact of my seeing it.

The curio shops in Kioto deal almost exclusively in Chinese objects and Corean wares, but for these they ask such prices that I could purchase nothing. A small Corean cup is said to be worth two hundred dollars, while for an inlaid bronze vase of Chinese manufacture no less a sum than six hundred pounds is demanded. But what astonishes me most is the price of a little teapot of dark red earth, in which are small specks of yellow-ochre colour. The specimen shown me has a fractured handle, hence I may have it for four hundred shillings, while if it were perfect it could not be sold for less than four times this sum. Specimens having the yellow specks somewhat larger are worth about six pounds each, the latter being an imitation of the former; but the secret of production has been known to but one man in each case.

In the evening I went by invitation of the Governor of Kioto to a temple garden, in order to see what is called the "tea-service" or "tea-ceremony"—the *cha-no-yu*, which the Governor has had prepared in a building set apart for this purpose. I saw, however, only that part of the service peculiar to the hours five and six o'clock. In connexion with every large temple there is a small house appropriated to the performance of this ceremony, and any one can engage the house for this purpose. A similar house is attached to every large residence or *yashiki*.

Here, as I saw it, and as it is performed at the temples, a paid professor of etiquette is the host; but if friends are invited by a man of high rank, he himself performs the part which the professor now takes. Only four guests besides the master should be present. The room in which the service is held is small, its floor being covered by four and a half mats (each mat is six feet by three). The house is entered by a hole or window opening, two feet square, which, although level with the floor of the room, is

about sixteen inches above the outer ground. Properly enacted, the service, my host tells me, begins at seven in the morning, and is continued till one o'clock in the following night.

The great peculiarity of this tea-drinking ceremony consists in the exactness with which everything is done. A spoon, cup, ladle, or whatever is handled, has to be taken hold of in a particular way, set down in a particular place, and touched in a particular part; and everything is done with the same strange precision.

What I saw was part of the ceremony of "thin tea-drinking," and part of the ceremony of "thick tea-drinking;" but the whole is simply a lesson in those laws of politeness, which were formerly so rigidly exacted in every mansion and on every state occasion, and which are still largely kept up in the houses of the old aristocracy. Originally the ceremony was of a secret character, and no servant entered the house in which it took place—the master kindling the fire, boiling the water, making the tea, and, in short, doing everything for the guests; but in later years it has become a mere ceremony of an extremely fashionable character.

One or two things in this service struck me as especially strange. Thus, both host and guests knelt from the time they entered the building till the time they left it; and even when the master had to go to a little back room to fetch water, cups, or whatever he might require, he shuffled on his knees to the slide which served as a door, and then, having opened it, shuffled through the opening till he was well on the other side, when he rose to his feet; but this he must not do while in the presence of the guests. The chief guest, moreover, is the spokesman for the company, and no word is uttered save by the chief guest or the host during the service, be it ever so long. The chief guest also demands everything: thus he asks for tea, and for refreshments; but the particular moment at which each request has to be made is arranged by the code of etiquette. At opportune moments the chief guest also asks if he may look at the tea-caddy, a spoon, a bowl, or the teapot. Receiving the necessary permission, he shuffles on his knees to the place where the object demanded

is, takes it, bows his forehead to the ground, then rising, touches his forehead with the object received, and begins to examine it. Looking at the teapot, he asks if it is silver, then who made it; then opening it and smelling the tea, what the tea costs per pound; after which inquiries he passes it to the next guest and makes a remark to the host which should, if possible, be at the same time a compliment and a pun. After each of the guests has duly inspected the object, the chief guest shuffles again across the floor and returns it to its place. Object after object is brought, examined, and returned in the same manner.

It is on these occasions that the rare things of the household are used; and the pride which a Japanese manifests in the possession of some little tea jar, a spoon, or a cup by a celebrated maker is something remarkable. But many of the things most esteemed by the Japanese would be unappreciated in Europe. One little tea-box is put in a silk bag, and then in a box, and then in another bag, and then in another box, in order that it be preserved; and I have seen little rough stone-ware jars encased in a similar manner.

The two hours which I spent in observing the ceremony *cha-no-yu*, were passed in the host making, and our sipping certain kinds of tea. One decoction, as thick as gruel, and as bitter as soot, is formed of tea-leaves reduced to the finest powder, and mixed into this batter-like condition. This is served as a loving cup, all drinking from the same vessel; in this case, politeness demands that each guest offer the cup to his neighbour in such a manner that he shall naturally drink from a different part of its edge.

I learnt afterwards from Mr. Sakata that at these meetings private matters are often discussed and secret plots concocted, and that most of the revolutions of Japan have been planned at these secret gatherings.

In the way of manufactures, I have seen in Kioto the making of much pottery, bronze-work, lacquer, and *cloisonné* on porcelain. I have also seen the weaving of fabrics, the printing of crapes, the working of embroidery, and many other industries; and I am now

getting a considerable insight into the means by which the Japanese achieve results. Having spent as much time as I can spare for one town, we pack up and start for Ōtsu on Lake Biwa.

Our road is over the hills at the back of the hotel, and here we see several small potteries in which a kind of Awata ware is made. In half an hour we reach a point at which an already good road is being improved, and here we have to walk while our jinrikishas are carried, for although we could ride with ease, and although horses and oxen are passing with their burdens, a notice saying that "carriages are not allowed to pass here" must be obeyed.

We are soon, however, on a normal road which, at the end of four miles crosses an elevation and then commands a view of beautiful Lake Biwa—a sheet of water which reminds me of the Lake of Geneva. At this season the mountains surrounding it are all snow-clad.

After a journey of seven and a half miles, we reach the little town of Ōtsu, the only manufacture of which is, I am told, silver teapots. From this place we make an excursion of some two miles to a temple, from where a charming view of the lake is obtained, and here I may mention that eight celebrated views of Lake Biwa are counted by Japanese, of which this is one.

From this temple, perched high on a hill, this end of the lake appears to be about three miles in width, and in the clear atmosphere I can just see the snow-clad mountains at the other end.

Although we had intended to take up our abode for the night at Ōtsu, the weather is so fine and the air so bracing that we continue our journey to the town of Ishib, twenty-two miles from Kyoto. Soon after we resume our journey we reach a village in which every one seems to be occupied in the manufacture of such silk cords as they attach to fans, tie around lacquer boxes, etc. About three miles farther on is a small town named Kusatsu, where scarcely anything is sold but bottle gourds.

A bottle gourd is simply the indurated skin of a fruit allied to our cucumber and melon, but having an hour-glass shape. Such vessels are generally called pilgrims' bottles. The usual colour

of these gourds is a dark rich brown, but here are some which are yellow mottled with black; others orange mottled in the same manner, while some are almost red. Of these gourds I got samples.

We now re-enter our vehicles. Our coolies run well, and the evening is most pleasant; but suddenly there is a jerk and a crash, and I am on the roadside. One side of my jinrikisha is broken to pieces. A moment's investigation reveals the cause of my little mishap: the linch-pin has come out of the wheel, and the wheel has rolled yards in front of us. As I am not hurt this little incident only causes amusement, and the poor coolie whose jinrikisha is broken heartily joins in the laugh.

Arrived at Ishib, we take up our abode at a pretty little Japanese hotel. Having brought a few European luxuries from Kioto, and being as hungry as a hunter, I make a hearty meal of Liebig's extract of meat, boiled eggs, bread, jam, and rice.

This hotel is in part furnished in European style, for it possesses one chair; but this unexpected furniture rather increases than removes my difficulties. Occupying this one seat, while the paper on which I wish to write is on the floor, or putting the paper on the chair when I have nothing to sit upon, is far from comfortable; at last, however, I overcome the difficulty by sitting upon a Japanese table (which is a small tray on legs of about four inches in length) and writing on the wooden seat of the European chair. While I write Mr. Sakata indulges in a cigarette, which he tells me is one of a hundred that he bought in Kioto for fourpence farthing. He also informs me that these cigarettes are good; but not being a smoker I can form no opinion of their merits.

*March 7.*—We rise at 6.40, and by 8.15 are on our road for Kamiji-yama, in Isé, a town in which the great Shinto shrines and universities are situated; indeed, much of the province of Isé is in some way connected with Shinto or, as we Europeans express it, Shintoism.

The morning is fine, and for some distance the road is very beautiful, snow-clad mountains being visible on either side. In

about five miles we reach the village of Minakuchi, where "vine baskets" are made. These are little baskets formed of the shoots of the westeria creeper, but there is nothing of special interest about them. I should rather have expected to find such objects as I here see in the shops of Margate and Ramsgate than in those of a Japanese town.

Crossing a ridge of mountains, and descending by many steep zigzags into a beautiful valley, we soon leave the main road (the great Tōkaidō), and turn to the right to run along the promontory of Isé. The scenery now becomes less and less interesting; but in the distance before us, and across the bay of Owari, are high ranges of mountains, while behind us are also snow-clad hills.

By 1.30 P.M. we have reached the small town of Saka-no-shita, where we have luncheon, and here we lose an hour in changing jinrikishas. Hundreds of soldiers are passing along the road in the direction of Kioto, and the officers all drive. At last fresh vehicles are found, but the men will only agree to take us four miles on the road, hence a little later a further delay occurs, and another hour is lost.

By 6 P.M. we have reached Tsu or Anotsu, the chief town of the province of Isé, having come forty-four miles in the day. During the latter part of our journey nothing very particular has happened save the coming out of a linch-pin of Mr. Ishida's carriage, when he broke the jinrikisha and rolled out,—an experience precisely similar to mine of yesterday.

A cook was engaged at Kioto for this tour, but last night when his services were first wanted it was discovered that he could not cook. When Mr. Sakita gave me the sad news he also brought the glad tidings that one of the jinrikisha-men (an intelligent-looking person) "could boil eggs and *make* beefsteaks." This is the very genius that we want, for beefsteaks are rarely to be found ready made here in Japan. My luncheon to-day consisted of five boiled eggs, some rice and jam, and this is about the best of food which I expect to have during most of my journey; yet the glorious air makes me thoroughly enjoy my meals. As for wine and spirits, I have neither seen nor tasted

them for over a month. The jinrikisha-man who can make beef-steaks is engaged to go with us to Tokio. To-day he was one of two who pulled me twenty miles, then he ran twenty-four miles, pushing up hills and looking after everything, and here he is as fresh as a daisy.

In the evening Sakata presented me with a most interesting relic, in the shape of a large curious knife, with bent damascened metal handle and a curved blade. The crest, Fig. 52, consists of four of these knives. This was used by ladies in warfare, being thrown at the victim while still attached to the owner by a chain. In the morning we rise at seven and are soon on our way. In two hours we reach the little town of Inaki, where all the best paper-leather of Japan is made. As here manufactured this material (which is formed of a thick fibrous paper and an oxidisable oil) so closely resembles certain kinds of leather—as morocco and calf—as to deceive a European expert, while other specimens bear but a faint resemblance to a tanned skin.



FIG. 52.—CREST OF A JAPANESE PRINCE.

In Japan leather is sparingly used ; but this paper-leather is most extensively employed where we should use the real hide. The stout solid quality made at Inaki rarely, if ever, finds its way into the European market. The paper-leather which comes into our market is made chiefly in Tokio by Isé men who have gone to that district to live ; but this is thin and fibrous and only leather-like on one side, whereas that here made is stout and leather-like on both sides. That of Tokio, however, is generally stamped, while that of Inaki is generally plain.

At Matsusaka, which we next reach, many houses have been burned down by insurrectionary farmers, who object to the taxation with which they are burdened, and it is feared that they may continue their work of destruction, for they have declared that unless their taxes are lowered they will destroy every town in the country.

In another hour we pass through a large village, the sole manufacture of which is that of common flutes. Here we rest



for a few minutes ; and here, as a substitute for tea, we are offered hot water in which pulverised red cabbage and salted plum have been sprinkled, but so little of the flavouring material has been added that I cannot distinguish any special flavour.

By 2.30 we have got to a charming little village on the sea-coast, called Futamigaura, where we have tiffin in one of the most lovely houses that I have ever seen. Our room is clean beyond the conception of even a Dutchman, has perforated panels of great beauty over the sliding partitions, and is possessed of an exquisitely beautiful bay window. I am in a room the like of which I have never before seen ; and the balconies, gardens, and entire belongings of the hotel are as lovely as the room in which we sit.

While tiffin is being prepared we walk to the sea-shore, which is about three hundred yards distant. Here in the sea are two rocks about two or three hundred yards from the coast, the one rising to the height of about fifty feet, the other about twenty feet. These rocks are connected together by large straw ropes, from which Shinto tufts are pendent ; and for hundreds of years they have been so joined,—new ropes at times replacing the old ones. At certain seasons of the year the sun is seen to rise exactly between these two rocks, and under the Shinto bands of straw.

When the sun thus rises pilgrims come in numbers to worship it, and even now, although this is not the proper time for pilgrimage, I see one or two Japanese, with hands pressed together, standing in devout adoration of the orb of day. On the shore just opposite the rocks is a torii, or gateway, and a small dais on which are hundreds of little earthen frogs and a number of small coins (the coins are nearly all tenth parts of a half-penny). The frogs are purchased from a priest who lives near at hand, and are offered to the rising sun. I get some of these frogs, and drawings of the sacred rocks, such as pilgrims buy in remembrance of their journey to this sacred spot.

Here, under the Shinto symbol, we have the worship of the sun, while in Kioto and Kobe pans of fire were being burned at

Shinto churches ; thus the fact that Shinto embraces fire worship among its tenets is apparent.

On our way to the hotel we passed many booths erected for the sale of shells, shell necklets, etc. These booths are situated amidst pine-trees which reach from the near mountains almost to the sea.

After luncheon, we reached in one hour the prettiest and best town, as regards the style and size of the houses, that I have yet seen in Japan. But all the towns in Isé are very superior to any that I have hitherto noticed,—even to those of Tokio or Kioto, and this province appears to have more towns, and a greater population, than most of the provinces of Japan.

This town, called Furuichi (old market), we pass through (yet it has temples and shrines of great moment), and go on to Kamiji-yama, a town in which the Holy of Holies of the Shinto church, and the great Shinto university are situated.

Although as a town Kamiji-yama is not quite so interesting as Furuichi, it is a prosperous and flourishing place.

My escort now select an hotel with which I am somewhat dissatisfied, as we have passed many much more beautiful tea-houses. But my guide tells me that those houses which I regarded as hotels are really places set apart for the performance of certain dances peculiar to the town,—the amusement seems to be a recompense for the fatigues of pilgrimage.

We soon reach the entrance of a sacred grove where we are met by a priest and two laymen who are to be our conductors to the holy places ; but we are at once told that no one can go within the temple enclosure unless sent as a messenger from the Mikado to pray for his people. We enter the magnificent grove of trees, or rather the broad well-kept pathway which leads through a small dense forest of immense cryptomerias. Here is a tree which actually measures twelve feet in diameter (thirty-six feet in circumference) at six feet from the ground. On our right is a river two-thirds the width of the Thames at Cookham, and with a bank which at the other side reminds me of Cliefden. To this river a way is made, broad and with steps. Here we are

told by the priest to wash, as no one can approach the sacred shrines unless he has here performed his ablutions. We go to the water, and after rinsing our hands are ordered to wash the mouth. To do this, we have to lade water from the river by the hand as a ladle. This done, we go up the lovely avenue.

It is five o'clock ; the rays of the sun pass brightly through the trees, and tip the distant hills with glory. The air is balmy and soft, and the sky is blue and bright. We soon reach a gateway ; simple yet beautiful, formed of pure clean pine-wood and raised on two steps ; but while the gates are open, the opening is closed by a large white curtain cut in the manner of Shinto. On the steps are hundreds of small coins and papers in which money is wrapped.

We make our offering to the temple, and as it is a little larger than that made by most of the Japanese, the priest draws the curtain aside in order that we may look into the enclosure behind, but I see only closed pine-wood gates with strong brass bindings.

We are now standing in front of a series of buildings of the greatest possible interest ; and few shrines in the world have enjoyed an unbroken celebrity equal with that of the temple before us. Every building in this enclosure has been absolutely razed to the ground every twenty-one years for more than eighteen centuries. Built eighteen hundred and eighty-one years since, they have been completely destroyed and rebuilt and destroyed and rebuilt during this period, but every block and every pillar in the present building is the exact counterpart of those in the building erected eighteen hundred and eighty-one years since—this destroying and rebuilding securing a perpetual youth to the shrine (Fig. 53).

The great symbol of Shinto is a mirror ; for, just as a mirror reflects our image, so, symbolically, Shinto is considered to reveal our innermost actions, or to reveal our innermost heart. I am told that in the central buildings within the enclosure, at the entrance of which we stand, is preserved a mirror sent down from heaven in order that man might therein see himself, and that the god worshipped at this great shrine is the first man—the Japanese

Adam. But the educated classes now think that this so-called "first man" was either a Chinese or a Mongolian.

We now walk to the side of the temple enclosure and from

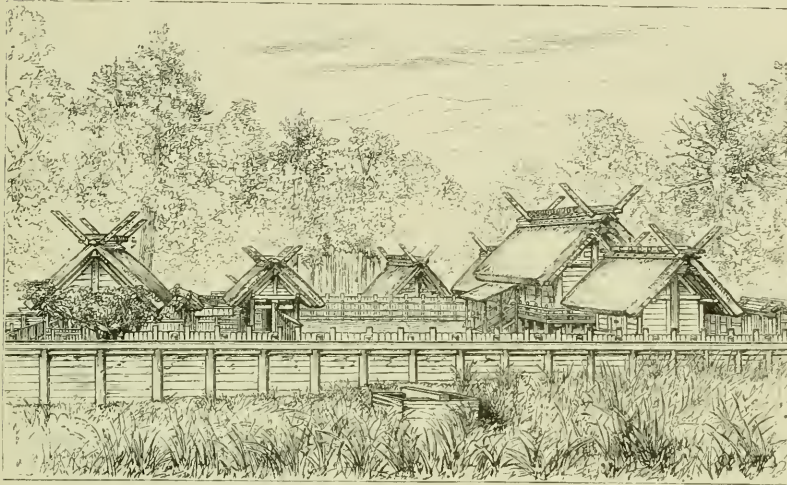

FIG. 53.—THE SACRED SHINTO SHRINE OF KAMIJAMA IN ISÉ.

slightly elevated ground get some idea of the nature of the buildings, and of the railings, or walls, by which they are enclosed.

The temple or shrines are enclosed by four courts, one within the other, the outer being bounded by a wooden fence, or wall, about ten feet in height, and consisting chiefly of horizontal planks of wood (Fig. 54), but the others I fail to see from my present position. Yonder, however, is a high mound of earth, and for this I immediately make. Here I see

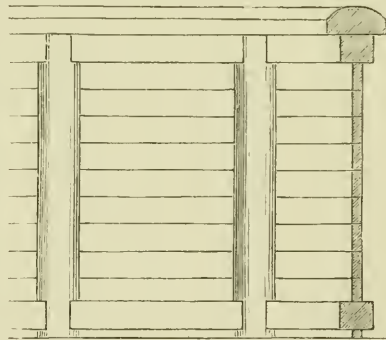

FIG. 54.—OUTER WALL OR FENCE OF THE GREAT SHINTO SHRINE.

that the second fence is of a very open construction, consisting of alternate short and long circular uprights, with two horizontal members connecting them (Fig. 55); that the third is more like our ordinary wooden fence, consisting of square uprights, with two

horizontal members to which square-topped staves are nailed (Fig. 56); while the fourth, and last consists of uprights and staves closely juxtaposed, the tops being somewhat narrowed, and thus

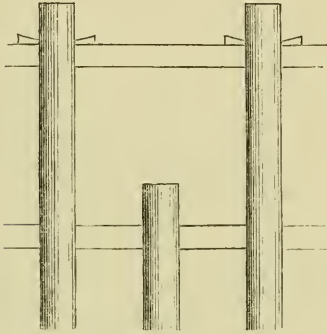

FIG. 55.—SECOND FENCE AT THE GREAT SHINTO SHRINE.

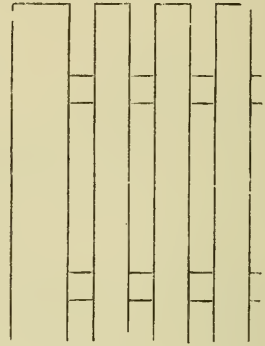

FIG. 56.—THIRD FENCE AT THE GREAT SHINTO SHRINE.

slightly separated (Fig. 57). These fences are all formed of clean pine-wood, having neither paint nor lacquer upon them.

From our vantage ground we can see five buildings; three, of which the centre one is largest, being arranged in a row at the back of the inner court, while the

other two stand in front of the central and larger building, and are connected by a sort of covered way. The two latter buildings are entirely separate from the other three, the innermost of the two being situated at the boundary of the inner court. All alike have thatched roofs with the chief supporting members continued through in a curious manner; while on the ridge rests a series of spindle-like bodies.

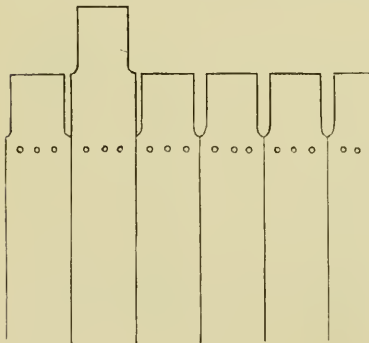

FIG. 57.—FOURTH OR INNER FENCE AT THE GREAT SHINTO SHRINE. This encloses the central court, at the end of which stands the building containing the mirror sent down from heaven.

These I am told indicate the rank of a Shinto temple. It is in the central building at the back of the court that the mirror sent down from heaven is preserved. This building, at a height of

about five feet from the ground, is surrounded by a covered balcony, approached by a central staircase.

To a large portion of the Japanese these buildings are the most sacred and the most interesting of any in the world. Shinto was the religion of old Japan, and it has always been the religion of the Mikado, while now it is once again the declared national religion of the country. To this shrine for nearly two thousand years millions have made pilgrimages; and in this uninterrupted succession of its glory there is something singularly impressive.

Having left the sacred grove we walk through a bazaar consisting of booths arranged under overhanging trees, where all sorts of trifles are offered for sale. Here touting is carried on to an extent new to my Japanese experience. We are in a very Babel, where eloquence is lavishly expended on every visitor, with the view of inducing him to buy what is here offered for sale. But while all press their wares upon us, none are rude or offensive in their manner. Amongst other small purchases I bought a carving of the god Daikoku, so small that it is enclosed in the husk of one grain of rice. In another husk I bought the two gods Daikoku and Yebisu sitting side by side. When seen through a magnifying glass they are almost as perfect as a pair of the gods an inch and a half in height which I also procured.

After dinner we sallied forth to see one of the dances for which Kamiji-yama is celebrated, and soon reached the dancing-house. We here enter a large room almost square; but around three of its sides there is a sort of passage, although not cut off from the room, for here the roof is much lower than in the centre, and columns which support it divide this part, more or less, from the centre of the room. The walls are hung with vertical strips of white, red, light blue, dark blue, and green cotton cloth, each strip being about ten inches wide, while it is margined above by a white calico frieze of the same width as the coloured strips, and bearing a crest of the form of a cart-wheel. A long carpet crosses that end of the room where there is no passage-like space, and upon this we are asked to sit, while running throughout the

length of the central portion of the room at the right and left are two long carpets, on each of which rest three girls who play instruments and sing. Lanterns hang from the ceiling of the passage-like space, and candles on tall candlesticks stand here and there in the middle of the room. As the music and singing begin the lanterns around commence to ascend, while the floor of this passage-like part also rises to the height of about one foot above its former level. This raised dais, which surrounds three sides of the room, is instantly bordered by a low railing, but how that railing got there, or how it got away when the dance was over, I do not know, for it appeared both to come and to disappear instantaneously.

Before each of us as we sit, and placed on a little stand, is a packet tied round with red string and bearing the little device which symbolises that it is a present. We may here remark that in Japan, every object which is intended as a gift is tied with cord of a particular sort and furnished with a little piece of coloured and folded paper, to which is attached a small dried slice of the "ear fish." The packet placed in front of us as a gift contains the words of the song; but on each tray there is also a pile of little cakes shaped like the wheel-like crest which decorates the frieze around the room. The lanterns bear the same device, and a little bridge over which we had to pass to reach this dancing-room has a large half-wheel as the balcony.

The lanterns having been raised nearly to the ceiling, and the platform with its marginal rail being in position, the dancers enter almost behind us to the right and to the left, and march slowly and solemnly till they meet in the centre of the aisle facing us. The dancing consists almost exclusively of graceful motions of the hands, the body only assuming a slight swing, while the feet move but little if at all. This dance is of ancient origin, and is not to be seen in any other town in the country.

After the dance has been continued for about five or seven minutes, the dancing girls slowly march out as they entered, the music girls leave, the dais sinks, the lanterns descend and all is over.

## CHAPTER VII.

Tidings of rebellion—Isé—Yokkaichi—Manufactures of Nagoya—Comparative estimates of wealth and skill—Castle of Seto—Sidsuoka—Fujiyama—Return to Yokohama.

WE now learn that the province of Satsuma is in open revolt against the Government, while the neighbouring county of Hiego has taken up arms with the view of expelling the hateful foreigner from the country, and that hard fighting is going on in both districts. Both the gentlemen who form my escort are, it seems, from Hiego; and I remember that a few days since Mr. Sakata said with much warmth, "before the foreigner came we were perfectly happy" (emphasizing the word *perfectly*), "and all were contented, while now each is striving to get an advantage over the other, and no one is happy."

This opinion is that of one who, while now a Government officer with but small pay, would have been a samurai or fighting man of considerable position, and whose father has been a great sufferer through the destruction of the baronial system. The feelings of my escort have just been embittered by an edict, issued since we left Tokio, which states that as the agricultural classes have protested against the excessive taxation imposed upon them, the Government have resolved to reduce the taxes on the land, and have consequently determined to lower the salaries of all Government officials by one-third, so as to render this reduction of taxes possible.

While I am sure I can trust both Ishida and Sakata, one cannot help wondering what may happen next. That much of the country seems ripe for rebellion is certain; and I confess that



I have some sympathy with my Japanese companions in their dislike to the intrusion of the foreigner, for while we have gained much in the way of art knowledge by the opening of Japan to us, and although we have given telegraphs and a hundred other useful things in return, we have done much to make a happy people unhappy, a satisfied people dissatisfied, and a contented people avaricious; while the beautiful monuments which are everywhere going to decay would have been preserved and cared for had not European ideas been spread throughout the country.

At the present moment Japan is in a trying position. It has overthrown a system which has worked well for centuries, while it has not yet had time to reap the advantages which in time will accrue from the new state of things. Besides this, the people, unfortunately for themselves, have taken to luxuries of which they knew nothing before the opening of the country to foreign visitors, and that to such an extent that their imports for some years past have been greatly in excess of their exports. Thus the country is being positively drained of its wealth.

As an illustration of the change which many have experienced through the altered state of things, I may mention a case that has come before my own notice. A gentleman who is in the Government service tells me that his salary is now one-eighth of what it would have been under the old feudal system, while things have increased amazingly in price since the opening of the country to the foreigner.

When descending Mount Koya-zan I was compelled to abandon my boots, and adopt the Japanese straw shoes. This led me to ask the value of these sandals which I had constantly seen the coolies use, and the answer was that they cost eight-tenths of a half-penny per pair. When I expressed astonishment at the lowness of the price one of the party exclaimed, "No! they are not cheap—they are very dear; I can remember when eighty pairs were sold for a halfpenny," and then the matter was put to me in this way. These poor men get but threepence a day for dragging us, and as they wear out two pairs of sandals between morning and evening in so doing, one-fourth of their entire income is expended

in purchasing the necessary protection for their feet. Assuredly we should regard it as very serious if we had to spend a quarter of our income in boots. We can now understand the enormous change which has taken place in the circumstances of some of the old samurai and nobles, for not only have their incomes been materially reduced, but the value of money is so much lessened, that men whose income is now in money one-eighth of what it formerly was are practically not a twentieth part as rich as they would have been under the old state of things.

In the morning we set out to see another great Shinto shrine at the opposite end of the town. It is in many respects like the one which we saw yesterday. Both appear to have the same number of enclosures and the same form of palings bounding the courts, but the arrangement of the buildings is different. Like the other, this is also surrounded by beautiful trees. We are admitted to the outer court, and from this we can see through to the more sacred enclosures beyond. But I see nothing calling for special notice.

Leaving Kamiji-yama, we retrace our steps along the great promontory of Isé, and in two hours reach the town where so many houses have been destroyed by agricultural insurgents. After a time we pass through the village where flutes and whistles are made, and then another about a mile long, devoted entirely to the manufacture of paper leathers. My request for permission to see the process of manufacture was met by the rejoinder that it would take fourteen months to see any one sheet of leather-paper made.

The fact is that in these Japanese villages everything is on so small a scale that the consecutive processes can rarely be seen at the same time. Division of labour is but little understood, and the potter who "throws" the clay generally turns it, bakes it, glazes it, and not unfrequently decorates it; and other manufactures are conducted in a like way.

While this method of working renders the study of Japanese industries difficult, it yet secures many advantages, for the potter who makes his wares entirely with his own hands has a pride and

an interest in them, which no one who simply "threw" the clay, who fired the biscuit, or decorated the ware, could have. Each piece of ware produced entirely by the one man is to him a sort of child that he loves; he has watched its development through all its stages; he has nursed it tenderly, and he has done all that he could to give to it beauty of form and perfection of character. I have viewed, with no little interest, the satisfaction depicted on the countenance of a manufacturer of this kind when signing the completed work. There is as much pride in Japan manifested by the maker in completing a little cup, a lacquer box, a sheet of leather-paper, or even a pair of chop-sticks, if the work be but excellent, as there is in one of our great artists contemplating an historical painting; and by perfect work any handicraftsman in Japan may attain to the celebrity enjoyed here by a Landseer, a Turner, or an Owen Jones, and the fame supplies a stimulus for the production of work still more excellent.

The next place which we reach is a small village in which waterproof paper is made, such as the peasants use for wrappers, capes, and rain coats, and such as furnish the "aprons" of the jinrikisha. Here also are made the mushroom-like hats of the coolies. In the street we see some mounted travellers, two women and one man carried by one horse,—the man squatting on its back, while a woman was suspended in a sort of scale at each side. Travellers here generally ride, while in all other parts that I have visited they almost invariably walk.

Here in Isé things seem prosperous. The houses are larger than in any other part of Japan, and are usually of two, and sometimes three, stories in height. They are also differently constructed, having the gables in all cases directed towards the street.

I have noticed in this province some grand street-lamps, formed wholly of wood, with lanterns three feet across at their broadest parts, and with roofs most carefully made of small wooden tiles, if I may so express myself (Fig. 58); but in one or two cases the effect of the lamps has been marred by a second rough roof being placed over the first to protect it from the weather.

We see nothing more to interest us till we reached Yokkaichi, the town for which we are making. Our road for nearly all the way has been over a sandy plain which, though now paddy fields, must at some recent time have been reclaimed from the sea. On our left are snow-clad mountains, but owing to the dulness of the day we can only just make out

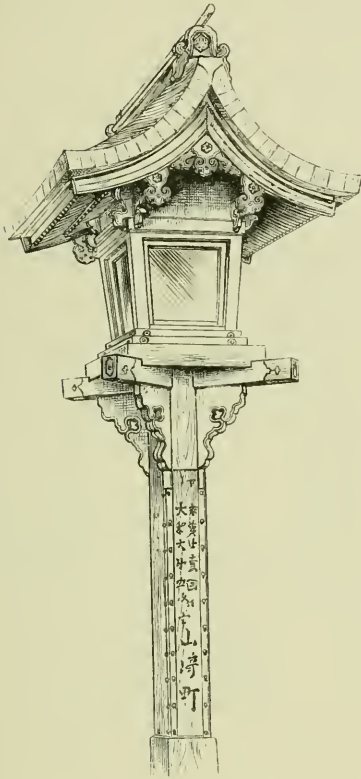

FIG. 58.—LAMP-POST.



FIG. 59.—BANKO TEAPOT.

the hills over the bay of Owari at the right.

We arrive at Yokkaichi, the seat of the Banko potteries, at 6.35 P.M., having come rather over forty miles in the day. Our coolie who can "make beefsteaks" has run with us the whole distance that we have travelled from Kioto, and yet he appears in no way exhausted.

Yokkaichi is in the province of Isé, but here the special features of the country are lost, for we are close on the borders of another province. The factories here are as usual small. The special characteristic of the wares of this town is that they are made by the pinching of the clay between the thumb and finger, and not by any process of "throwing" on the wheel (Fig. 59).

Bankō wares are generally unglazed, and the earth of which

they are made is most commonly of a soft Portland-stone colour ; yet objects of dull salmon-red, of white, and of dark brown, are occasionally produced.

After a long round of the potteries, with which I was much interested, we started for Owari. When three miles on the road we came to a pottery owned by a man whose father re-invented Bankō ware, and in about three miles more we enter the rather large town of Kuwana through a large bronze torii. Here we see a number of potters who make common Bankō wares ; but one makes a specialty of vitreous painting on pumice stone brought from Idsu. This pumice stone is sometimes in the form of slabs, and sometimes in the form of pots, such as the Japanese grow flowers in.

In this town of Kuwana there are one or two leading potters and a great many small ones, but all make the same wares. I ought perhaps to add that the largest pottery here would probably in no way be comparable in size with the smallest in Great Britain.

We left Kuwana by boat, being rowed about five miles along a river, and then after some delay set off in jinrikishas for Nagoya, distant about seventeen miles from our landing-place.

Nagoya in Owari is one of the important manufacturing towns of Japan, and besides its manufactures it has many curio shops. Here are made the low-toned calico prints in which pilgrims carry their little luggage, and here also is the chief seat of the *cloisonné* (or *shippo*) manufacture, both on metal, and on porcelain with the interstices filled with lacquer. Earthenware cabinets, much bronze ware, that curious porcelain which has an iron-like surface and a gold pattern resembling Damascened metal-work, and that soft-baked crackle-ware which is covered externally with chequered lacquer, are made here. Nagoya also stands in the centre of the great Owari pottery districts.

Near the curio shops is a temple with a gate richer than anything I have hitherto seen (Figs. 60, 61). Its uprights and cross-beams, as well as the panels, are carved with elaborate ornament ; and even on the two sides of each structural member the pattern varies.

Before I had risen the next morning the curio dealers had invaded the hotel, and spread their wares over the floors of each unoccupied room. This is a common practice here ; and I believe that little is paid for the privilege of thus displaying goods, unless sales are made, when a percentage is given to the landlord for

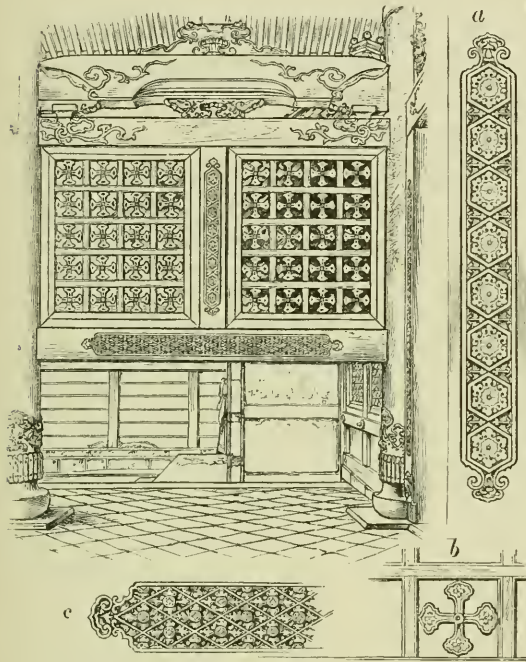

FIG. 60.—DETAILS OF GATEWAY TO TEMPLE IN NAGOYA.

*a*, Enlarged view of ornament on central upright ; *b*, of lattice ;  
*c*, of horizontal member.

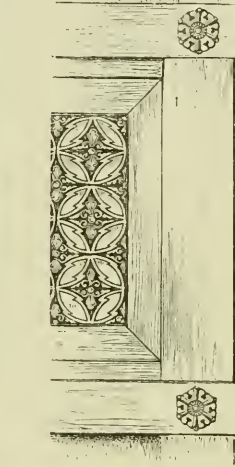

FIG. 61.—PORTION OF CARVED  
PANEL IN GATEWAY OF  
TEMPLE IN NAGOYA.

such trouble, I could not well help inspecting their things, yet amidst their collections I found but little of interest.

I received visits from the governor of Nagoya, who asked me to dine with him in the evening, and from Dr. Roretz, whom I recognised as one of our party at the luncheon in Tokio given to the Austrian Princes by the secretaries of legation. Dr. Roretz is physician to a large hospital established here for the cure of diseases by European treatment. He is the nephew of the Austrian minister at Tokio. During my stay in Nagoya he joined me in my excursions, and gave me much valuable aid.

the accommodation afforded. After these poor men had been to

Having visited the great Shippo company's works, and a pottery of some interest, we went to see bronze-makers, various metal-workers, and one calico printer.

In the evening Dr. Roritz takes us to see an enormous earthenware head of a *Dai-butz*, which stands on a waste piece of ground near a temple. This is made in three parts. There is a join underneath the hair, and another underneath the chin, but the central part measures five feet in height.

The governor's dinner was given in a suburban hotel where the garden was illuminated by lanterns, and most sumptuous the dinner was. Besides the governor and my two Japanese friends, the vice-governor and four others are present—the latter, like the Roman umbra, simply listening to what is said.

There is in Japan a little too much of the spy system, for I can scarcely go anywhere without some officer being present to report all that I say and do. Those Government officers who have been sent ostensibly for my protection have in some cases simply recorded my doings; and when no Government officer is present Ishida's pocket-book does good service in their stead.

In the morning we start on an excursion to the little town of Seto—one of the chief seats of the Owari porcelain manufacture—where we are met by the governor. Last night I mentioned to the governor of Nagoya that the system of having some one to record all my acts and movements was scarcely agreeable; so he promised that no Government officer from his district should accompany me to Seto, yet the governor of Seto lost no time in letting us know that he had been informed of our coming by the governor of Nagoya. This communication could have been made only by a messenger being despatched before our leaving Nagoya; the governor of Nagoya keeps to the letter of his promise, as he does not send any one with us to the pottery district, but he takes care that some one shall do the spying.

Here we are in the very midst of the blue-and-white porcelain manufactures of Japan; but in Seto many wares are made besides those which especially characterise the district. Among these are Celadon on white porcelain ground, dark rich purple-blue,

like the royal blue of Worcester, and undecorated vases of Satsuma earth.

The inspection of these potteries makes me feel still more the difficulties which beset the path of a student of Japanese manufactures, for the potters sell chiefly to dealers who are invited to attend at the opening of every fresh kiln. Thus all the wares which a man produces are generally sold as soon as they are made.

To-day I found that some of the best potters in Seto had not even one specimen of their work to show, while many had but few pieces, and those chiefly "wasters." There is also another difficulty, for much of the best Seto ware is taken to Nagoya to be painted.

It is a common practice to have wares which are made in one district decorated in another. The question then arises: Are we to regard an elaborately painted vase which has been made in Seto and painted in Tokio as of Seto or Tokio manufacture? Such questions as these constantly perplex the student of Japanese Ceramics; and as the decorator generally buys the wares from the potter and sells them as of his own manufacture, we in England frequently mistake the locality in which the wares are made.

But men who are merely makers, and decorators who are merely decorators, must rather be regarded as merchants, or money-makers, than as potters such as the Japanese esteem: and I may here remark, that in Japan the merchant has no status whatever, though he be rich as Cræsus. Money alone buys no position. A prince will spend hours in conversation with a skilled workman, and will receive him respectfully at his *yashiki*, but the richest merchant would be beneath his notice.

Who shall say that the Japanese are imperfectly civilised when they thus pay homage to learning and skill, and prefer these to wealth? Is not their civilisation, rather, higher than ours? Surely they here set an example to us which we should do well to follow! Here we worship wealth, while we pass unnoticed the handicraftsman, however great his knowledge or subtle his work; yet too often the merchant employing the handicraftsman has



secured his gains by acts of which he ought to be ashamed, and which can only result in the degradation of his nature. I cannot help thinking that the Japanese are right in regarding the man who can make a beautiful pot, a lovely cabinet, a charming fabric, or a perfect netsuki as a being superior to the mere buyer and seller of goods; for while the one devotes his best energies to mere money-making, the other ennobles matter by the impress of his mind, love, intelligence, and skill; for unless the work results from intelligence, skill, and love, it cannot be regarded as a noble production.

There is a vast difference between toil undergone for the sake of mere money-making, and the production of the most perfect works of which man is capable. No thought of gain enters the mind of the great artist while he is engaged upon his work. Much of the work done by the British workman is positively despicable, because his only thought has been how to make the most money with the least exertion of mind or body. But the loving, painstaking toil which the Japanese bestow upon so many of their productions is actually ennobling; and by such labour the workman rises necessarily far above the mere moneyed man.

Here, in Seto are made all the shapes for the *cloisonné* on porcelain manufacture, certain imitations of Satsuma ware, buff lustre wares, and many other things; indeed, Seto produces a large number of goods for home consumption, as well as many for the export trade. I have to-day bought at Seto a common sachi bottle, such as the peasantry would use, and for it I paid four rin and eight mo. For some time past the Japanese have adopted the American coinage; thus they have the dollar with its half, its quarter, and its hundredth part, or cent—each cent being worth about a half-penny of our money. But mixed with this new coinage is part of the old; thus elliptical coins worth eight-tenths of a half-penny, and circular coins worth one-tenth of a half-penny, are still as common in Japan as half-pence are in this country. Formerly iron coins were in use of the value of one-hundredth of the cent, although these are now withdrawn from circulation. I succeeded in getting a few pennysworth during

my journey ; and to this day quotations are given for some goods in these coins, just as our Manchester manufacturers quote eighths and sixteenths of a penny.

In this old money ten rin make one cent, ten mo make one rin ; but there were also in use during the baronial age coins of much smaller value than even these, but such coins seem entirely to have disappeared. There were coins called shi, of which ten make one mo, and there were also kotsu, of which ten made one shi : thus there was a coin worth a half-penny, another worth the tenth part of a half-penny, another worth the hundredth of a half-penny, and another worth the thousandth of a half-penny. The sachi bottle which I purchased to-day will be seen to have cost something under a farthing.

On the following morning we had nothing but delays. It was half-past nine before Mr. Ishida got back from the Government House, and I then learn that there was some difficulty about our getting to see the castle, as it is under the control of a military commander, and not of the governor of the town, who had invited us to see it.

Mr. Ishida has brought the bad tidings that an insurrection has now broken out in the north of Japan, and that the Imperial troops, while gaining the mastery in Satsuma, have to face new troubles in other quarters. But what concerns me most is the fact that the province of Suruga is in a most unsettled state, as we have to pass through it in order to continue our projected land journey. To-morrow we are to have exact news from the governor, but should we not be able to proceed, we shall have to return to Kioto (from which we are ninety miles distant by the nearest road), going thence to Kobe by railway, and on to Yokohama by sea. We may, however, catch a steamer which occasionally calls at a town only ten miles distant from here ; I can only hope that things are not so bad as they are reported to be.

On our return to the hotel, we found a Government officer waiting to conduct us to the castle ; but although we soon reached its massive gates, we had to put up with most tedious delays before we were allowed to pass them.

At last we are inside the walls, when we are shown into two rooms which have ceilings similar to the beautiful temple of Uyeno, in Tokio, and which are said to be of Corean design. There are here also, above the movable slides which form the partitions between the rooms, some magnificent wood carvings



FIG. 62.—WOOD-CARVING BY HIDARI ZINGORO. Preserved in the Castle at Nagoya.

of flowers and birds, which are coloured in a subdued and delicate manner (Fig. 62). While these screens are pierced and carved on both sides, both faces are yet essentially different; and the parts are arranged with such consummate skill, that those on one side help, instead of mar, the general effect of the other. These works are by one of the most celebrated wood-carvers that Japan ever had. His name was Hidari Zingoro, and he lived about three hundred years since. Through the kindness of the military governor of the castle, I have since been able to procure photographs of these magnificent works.

The immense towers of this castle, like those of the other castles that I have seen in Japan, have to me a Chinese rather than a Japanese look. It reminds me also of the Japanese palace in Dresden; perhaps it is only the green roof that does so,

for here the coverings of the immense towers are copper. Of the size of the towers I could have formed no idea from a distance ; and they seem as strong as they are great. Hundreds of soldiers could be accommodated on each floor, and from the window openings the entire surrounding country is surveyed. Curious wooden charts, fixed at the various openings, are so arranged that the eye may follow lines indicating the position of any place for miles round.

From what I have seen in the last few days I begin to think that there are hindrances to an increased commerce with foreign countries which Japan will, for its own sake, have shortly to remove. It is now pretty clear that out of the money which I have paid for certain objects four parties have had to be feed. The Japanese servant must have his percentage ; the Government officer who accompanies us demands his share of the spoil ; the gentleman who packs and forwards the goods, although paid for his work, must have something to encourage him to pack the things safely ; and if the goods have been bought direct from the maker he must pay to a guild of merchants such a sum as would be a fair profit on the transaction. Until all this is removed Japan cannot hope to become a great mercantile nation. As regards the English I can positively say that such a method is to them most objectionable, and is likely to cause a serious curtailment of business.

Another great difficulty lies in the fact that all things here are on a small scale, and the time needed for visiting the numerous little factories is greater than any exporter can give. No country that I am aware of has ever become a great mercantile nation until the manufacturer and the exporter have been brought together.

When our broad-cloth and our dress stuffs were made in cottages, what were called Piece Halls were built in the larger towns, and here each cottager could hire a room for a trifling sum. To these piece halls the little manufacturers brought their few lengths of stuff, and thus the merchant could by one visit, on certain days (market days), see the whole produce of the district,

while the manufacturers ascertained the prices which goods were fetching. If the Japanese would but establish, in certain central positions, such markets for the produce of districts, their commerce would be largely extended.

It was 3.15 P.M. before we could start to-day on our excursion to the Mino Potteries, a five hours' journey. It was dark before we reached our resting-place at Tazimi.

The next morning we were off by 7.30 to the potteries, taking Ichi-no-kura, where the better class of Mino wares are made, first in order. This village is about two and a half miles distant from Tazimi by foot-road over the mountains; but as there is a jinrikisha road to it, which is said to be but little longer, we settle to drive, for we have a hard day before us. It turns out that a mountain spur has to be rounded before we can reach Ichi-no-kura, and an hour and a half is spent in reaching it. This village is situated on two sides of a valley where it extends up the hills, just as the potteries of Seto do; and indeed, all the potteries of Japan seem to be situated on sloping ground.

The kilns in these pottery districts are of strange form, and consist of a series of arches with mud exteriors which rise up the hillside; and many potters burn their wares in the one kiln. In a pottery district the extent of the manufactures is estimated by the number of its public kilns. The province of Mino alone has a hundred and fifty kilns.

We first inspected the potteries on the side of the hill dividing Ichi-no-kura from Tazimi. Here we found potters making blue and white wares, earthen teapots like those of Bankō, sachi cups of many kinds, Japanese tea-cups and other things, some being well finished and nicely decorated. Here we also found decorators, not connected with any pottery, who are paid for any work that they may do, and who often purchase plain wares to decorate and sell.

On the other side of the valley are some excellent potters who make blue and white wares of great delicacy, and dishes in the form of bent *Nelumbium* leaves. One man's specialty is eccentricity in shape; but he produces a perforated ware which has its perforations filled with transparent glaze. This potter is known

in the district by the name of Hechibei, which being interpreted means "funny fellow." Another manufactures wares that look rather like our "mottled soap," being brown, gray, and white mingled together in a tortuous and striated manner.

After completing our inspection of the Ichi-no-kura potteries we walked over the hill to Tazimi ; and a delightful walk we had. The day was gloriously fine, yet there was a cool bracing air as the frost last night was keen. Ascending to the ridge and then turning to the left, we followed the crest of the hill for about a mile and a half, looking down on a most charming view, as a very forest of mountains extends to the horizon on all sides ; and so we reached Tazimi. The potteries here produce nothing but common blue-and-white wares of little interest ; but we found in one of the dealers a man of great importance in times gone by, who under the Baronial system had acquired from the Daimiô of the province the sole right of selling Mino wares.

Starting at 4.15 on our return journey, we reached Nagoya in less than four hours after having had a glorious drive.

The report that Suruga, the province where much woodwork is made, and to which we are now going, is in a disturbed state turns out to be untrue.

Next morning, therefore, we bade adieu to Nagoya, and following the great Tokaido (or main road) for about ten miles, came to two small towns almost joined together, the first of these being Narumi, the second Arimatsu. Here are made the crape scarves, and other fabrics, which have a texture resulting from the "tying up" of parts of the surface into tufts.

This manufacture is of a most interesting character, and produces effects which cannot be got in any other way. At one time this was a flourishing industry. But the European and American demand for a cheaper and still cheaper article caused a most delicate and delicious article to degenerate into the coarsest and most objectionable of stuffs. Recently an effort has been made to revive the original manufacture, and, I believe, with some success. It would be a calamity not only to Japan but to the world if such a manufacture as this were lost. Fabrics of this

character are called *Narumi-shibori*, the word *Narumi* being the town, and *Shibori* tied or knotted.

In these two villages common Japanese towels are also made. A Japanese towel, as I have already mentioned, is a piece of common calico about three feet in length and ten inches in width, on which a pattern of quaint character is printed; indeed all washing fabrics here are only ten inches in width. In Japan there is nothing equivalent to our ironing and mangling processes, and the only method of flattening a fabric after it has been washed is that of sticking the cloth to a board while yet full of water and there allowing it to dry; and as the poor in England each possess a clothes-line, so do the poor of Japan each possess drying boards. If a woman's dress has to be washed it is first ripped into the narrow strips of which it has been made, in order that these strips may be flattened on the drying boards.

A run of twenty-five miles brought us to the town of *Okazaki*, where there is one potter who has come here from *Kioto*, and whose wares are remarkable more for eccentricity than for beauty. He has left his former business to his son.

We left *Okazaki* at 3.15, and by 4.30 seven and a half miles had been run. As there remained yet twelve and a half between us and our destination I offered the men something in the way of reward if they would run well for the rest of the distance. To my surprise the twelve and a half miles were completed in one hour and thirty-five minutes, although we had stopped on the road at a village called *Hōzōji-mura* to see the gourds, to the preparation of which the whole village is devoted. At *Hōzōji-mura* we were asked as much as eight dollars (thirty-two shillings) for a bottle gourd holding about three half pints: but its value lies in its strength. Two such gourds may be knocked together with a vehemence that is astonishing without breaking. One of them is half an inch in thickness, and we are informed that when very old the rind of a bottle-gourd becomes thick, but that when the gourd is young its skin is thin. Mr. *Sakata* has a bottle-gourd which cost thirty dollars, being large as well as thick. I do not like the appearance of those sold here nearly so well as those which we

saw on our road to Isé, but the Japanese "colour" their gourds as smokers here "colour" pipes: and the young Japanese is as proud of a richly coloured gourd as an English youth is of a well-coloured "meerschaum."

We have now reached Toyohashi, in the province of Mikawa or Sانشiw, forty-five miles from Nagoya, on the great highroad to Tokio. It is the largest town, save Nagoya, between Kioto and Tokio; Okazaki being the next largest.

Our road has been across a valley most of the way, but for the last five miles we have been near mountains. All the day snow-clad peaks and long alpine ranges have been visible both on the right and the left, but especially on the left; and owing to the clearness of the atmosphere we saw Fujiyama again for the first time since we passed it on our way from Yokohama to Kobé by sea.

Since we started on our journey, neither Ishida nor Sakata have ever worn their national costumes in the street. In the day they wear European dress, and in the evening put on their national dress, with a dressing-gown (borrowed generally from the hotelkeeper) over it. I have just discovered the reason of this. Both, as I have before said, are from a province now in revolt, and as all Samurai wear their crests on their robes, their dress would reveal the fact of their being from a revolting province, and they would be constantly liable to arrest till the insurrection is over; for while their position in the Government service gives them immunity from imprisonment, much trouble would be involved in securing their freedom.

Having had a good night's rest, we rose at six, and by seven were on the road. The morning was chill. At nine o'clock the sun was struggling with a thin layer of cloud, but later in the day the heat became actually scorching. At 9.30 we reached a shallow bay nearly four miles in width, with a uniform depth of about eighteen inches. This we crossed in a flat-bottomed boat. Over more than a square mile of this bay bushes arranged in regular rows jut out from the water: these are to catch a kind of seaweed which entangles itself amongst them, and which is a valuable article of diet.



Having crossed the bay, we arrive at a little village, where the sole employment of the inhabitants consists in collecting and drying this weed. They spread it upon straws, like those on which we place "cream-cheese." Along the streets, and on the edge of the bay are propped, easel-fashion, a number of large square straw pads, not unlike our targets in make. The little straw mats being covered with seaweed, are pinned on these target-like slabs by wooden skewers, and left in the sun till the seaweed partly exfoliates, when it is removed for packing.

At this village we can get only two jinrikishas and two coolies. Mr. Sakata and I therefore go on, while Ishida follows on foot, with the baggage on a kind of hand cart or truck. As the road is of loose sand our progress is slow. In the village through which we are now passing nearly all the houses have in front gardens enclosed by well-trimmed hedges, some of which are as much as thirty feet in height. Orange-trees laden with fruit may be seen everywhere, and beside many of the houses stand lovely little shrines. At the next village we get an extra coolie each, and order a jinrikisha to be in readiness for Mr. Ishida. Along this road the scenery is more tropical than any that I have before seen in Japan, and strikingly resembles that of Java, while the houses are also very similar to those in that island.

Soon we come to a town of considerable importance, which has a look of prosperity about it that I have seen hitherto only in Isé. Here the gable ends do not front the street, and in construction the houses differ from all others that I have seen. I notice in the architecture during my travels varieties corresponding to those seen in the different Swiss Cantons. This town is Hamamatsu in Tōtōmi or Yenshiw.

After leaving this town we have nothing but bother with our coolies; but although at very short intervals we have to change jinrikishas, by 6.30 we have got over fifty miles. There is, however, a mountain ahead, and five miles more must be traversed before we reach our resting-place. Mr. Sakata and I set out to walk, leaving Mr. Ishida to follow with the baggage by kago.

The ascent is steeper than any road that I remember in

Switzerland. Darkness comes on, rain begins to fall, and it is nine o'clock when, tired and hungry, we reach Kanaya in the province of Tōtōmi or Yenshiw.

Morning! It rained hard all night, yet the morning gave promise of a fine day. But delay after delay arose with the jinrikisha men; and, finally, Sakata and I set out on our journey, leaving Ishida and the servant to do as well as they could.

The day turns out gloriously fine, and we seem to have got into thorough spring weather. Here the plum blossoms are fully out. Some of these are, strange to say, pink and double. We are in the midst of the mountains, and lovely indeed they appear on this glorious day. Fujiyama is before us—for a time cloudcapped, and then clear again—but its vast and peerless cone rises high above all surroundings.

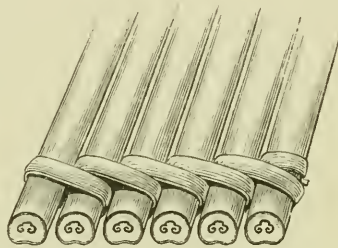

FIG. 63.—PORTION OF TABLE-MAT, FORMED OF STEMS OF THE BRAKE FERN.

By twelve we reached the town of Okabe in Suruga, where mats (Fig. 63), trays, fan-holders, chop-sticks, and other things are made from stems of the brake fern.

Although the coolies were refractory in the morning, they have certainly run well, for by 1.30 we have reached the town of Sidsuoka, which is also in Suruga. Here much woodwork is made; but only a few weeks since nearly one-third of the town was destroyed by incendiary agriculturists; now it is largely rebuilt.

Setting out to see the industries of the town, we visited a man who makes portable folding-desks of English pattern, partly inlaid. I bought one without polish, hinges, lock, or velvet, for eightpence halfpenny; yet, the expenses of transit are such that Bethnal Green can beat it out of the English market.

We next saw a manufacturer of bent bamboo trays, who performed his work with great skill, then a maker of inlaid woodwork, a man who forms bird-cages of vegetable wires, a man

who covers lacquer bread-baskets, and porcelain sachi-cups, with basketwork ; but all his productions are covered with coarse work, and not with that exquisitely fine plaiting which we formerly found on the thin porcelain. The reason why this coarser work is now produced was soon given. This man has imbibed the English commercial spirit, and found it pay better to make common things in large numbers, than the few of more delicate character. He also doubts whether any one now living in Suruga could cover cups with the fine work common ten years back. Here we have another instance of the corrupting influence of European trade on the Japanese industries. Since my visit, however, the fine old work has again been produced in this district.

The bird-cages made in Sidsuoka are noteworthy as works of great beauty and tenderness. What we may term the wires are of vegetable origin ; yet, for rigidity and truth of form, they vie with any metal thread ever produced.

Plain wooden trays, both circular and square, are here made abundantly. These the Japanese use for domestic purposes, and for offerings made to the gods.

Sidsuoka is an important town, engaged largely in the manufacture of inlaid woodwork, but it is unfortunately situated. Between it and Yokohama lies a high mountain range, over which no vehicle can pass ; and, as nearly all Japanese exports leave the port of Yedo, the manufactures must either be carried by men over the Hakone mountains, or must be sent back at least as far as Nagoya,—if not all the way to Kobé,—before they can be shipped to Yokohama.

The next morning we were astart early. A little frost was on the ground, but the sun soon gained power, and the heat became almost oppressive. It is only the 19th of March, but the heat is that of a July day in England. As we passed under the shade of richly-wooded mountains Fujiyama rose in the near distance on our left above a horizontal layer of white clouds which stretched across it, while on the right lay a lovely bay, bounded by a low range of hills, separating us from the great and sacred peak.

We stop a short time at an hotel, the back of which hangs

over the bay, and commands a lovely view of the great mountain. As seen from the pretty little room in which we now are, Fujiyama can be surveyed only with feelings of inexpressible delight.

Resuming our journey, we made our way round the mountain spur which separated us from the giant mountain, when the immaculate cone burst fully on our view. Here we cross one of those strange, broad river-beds, which are so common in this country, and from which the vast mountain rises, first gentle and then increasing in its slope ; becoming more and more steep as the summit is neared. But of the vastness of the slope, even to the bottom of the snow-line, no accurate idea can be formed, unless comparisons are carefully made. Large trees here appear as specks, extensive plantations as little patches, cloud-shadows no bigger than one's hand.

The height of Fujiyama is variously given as fourteen and as sixteen thousand feet. Unlike the Swiss mountains, which all have their bases far above the sea level, while many are seen only from ground much elevated, the great Japanese mountain stretches its base to the very ocean.

Monte Rosa is about fifteen thousand feet high, but it is best seen from Zermat, which is about seven thousand feet above the sea level ; and while Mont Blanc rises fifteen thousand seven hundred feet above the level of the ocean, Chamouni, from which it is seen, nestles in a valley nearly three thousand five hundred feet above the sea. Thus, as seen from its base, Fujiyama is higher than any European mountain. But its sublimity is due not only to its height, but also to its form, and the regularity of its snow-line, which invest it with a beauty peculiarly its own. I know of no other mountain so perfect in shape, so immaculate in appearance, and so majestic in its grandeur.

Our road leads us under another high bank, and here I notice violets, dandelions, potentillas, the ground ivy, and other plants in bloom, for in this low, warm district spring has thoroughly set in.

By 12.20 we have run thirty-five miles, and here one of our poor coolies faints. He is, I am assured, in no way overcome by fatigue, but is subject to fainting fits which might seize him at any

period of the journey. This little trouble over and a new coolie secured, we are soon on our road again. At 1.30 we reach a little town, where we have tiffin; and some of the men who have pulled us for the forty miles which we have this morning travelled, appear ready to start again.

We soon reach the great Hakone pass, over which no vehicle can travel, and for twenty miles we must either walk or be carried in kagos. Coolies are engaged to bear our luggage, and two kagos are hired, so that we may ride alternately if we please. The path now rapidly ascends, and we get lovely peeps of sea, bay, forest, and mountain, with Fujiyama high above all. Now the air begins to get cooler; patches of snow are seen in the shady hollows, then we have snow in quantities, but partially melted, till, as we near the top, snow and ice abound. Having gained the summit of the pass we descend into a little hollow, where a strange and picturesque village borders a lake of two or three miles in length, entirely bounded by mountains. The scene reminds me partly of Loch Lomond, partly of Killarney, and partly of some of the lakes in Westmoreland and Cumberland; but, as the lake is bounded at its distant end by Japan's greatest mountain, nothing in Great Britain, and nothing even on Lake Lucerne, is nearly so grand.

We are soon at the hotel, which stands back from the road.

Here we have another evidence of the change which has come over this strange country during the last few years, for the gateway through which we have entered the courtyard was opened only for Daimiôs and their retainers until after the revolution of eighteen hundred and sixty-eight, but now it is opened, not simply for Japanese of ordinary rank, but for foreigners.

Our hotel is situated on the left of the road, and in a slight declivity, its back rooms commanding the view of the lake and its surrounding mountains, and of a lovely little garden adjoining the hotel. From our rooms we watch the lake glimmering in the evening light, placid and still. The dark mountains stand out against the glowing sky; and almost in the centre of the picture, high above the nearer hills, rises the vast white peak of Fujiyama.

We gaze on the changing effects of the fading light as the reflected mountains disappear from the water till everything is lost in the darkness. It is hard to tear ourselves from this enchanted scene, but the window-slides are returned to their places, and the outer world is shut out from sight.

*March 20.*—A more lovely morning than this could not possibly be, and the view of the lovely lake, and of snow-clad Fujiyama, is beautiful beyond description. We talk about the matchless blue of Italian skies, but to me the sky which I here see almost daily surpasses anything that I have ever seen in Italy ; indeed, I never knew what fine weather really was till I visited Japan. Here I find an atmosphere of the greatest purity, with a crispness so refreshing and bracing, that I feel as if I never could inhale enough ; and never did I feel in better health, or more vigorous in constitution, than I now do.

By 7.10 kagos are at the door, and I am told to ride, as the snow on the side of the mountain which we are about to descend is thick and sludgy : I make an effort and succeed in partly packing myself in the horrible contrivance.

For six miles I am slowly carried by men who trudge through the snow with a steady and firm step, as though they were carrying a cage with a jackdaw in it, rather than a burly Englishman. Unalloyed enjoyment is out of question in a kago ; but I feel that the Hakone Pass, for beauty and grandeur, has few rivals even in Switzerland.

Four miles on the road, we come to a little town in the province of Sacami or Soshiw, called Yumoto-Kawabata. The people are almost all employed in woodwork and making baskets of special kinds ; but a few of the fern-stem trays, such as we saw in Okabe, are also to be found here, as well as much inlaid camphor-wood in the form of cabinets and boxes, wooden sachi-bottles, paper knives, and other things ; but I am most interested in the hats and baskets (Fig. 64) made of the plaited fronds of a large pinnate fern, which are both ingenious in make and beautiful in appearance.

Having passed another village called Yumoto, where exactly

the same manufactures are carried on we leave the great Tokaido, and in two or three hundred yards come to the Hakone springs. Here, as at Arima, we have a fashionable inland watering-place with natural hot wells. A new hotel of considerable size has a series of bath-rooms ;—the whole being clean and beautiful.

On our leaving this new hotel the landlord presents each of us with a little packet tied with the folded paper which denotes a gift, and containing a thin wooden box, within which is a little sachi-cup bearing the name of the hotel. The custom of giving

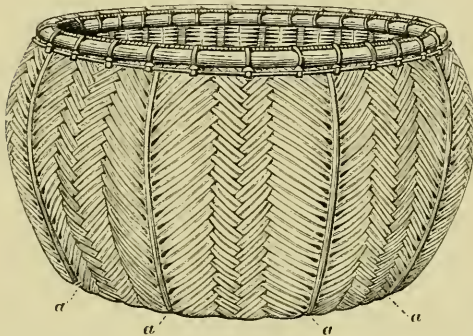

FIG. 64.—BASKET FORMED OF THE FRONDS OF A FERN.  
a being a Midrib.

a small present to the guests, it seems, is common in fashionable tea-houses in Japan ; and it is in vogue also at Wiesbaden and other German watering-places, where a fan is often given with the name of the hotel upon it.

I now find that a new road has just been completed from these hot springs, along which a jinrikisha can travel, and that one of these comfortable carriages can be got at the hotel. Seated in this vehicle, I feel as though I had been transferred from purgatory to paradise.

From the village to which the kagos had been engaged Yokohama is distant about forty miles ; but the coolie who has brought me from the wells agrees to run the rest of the distance, and by 2.30 we are all in jinrikishas and ready to start.

In the evening we reach Yokohama, and I take up my old quarters at the Grand Hotel.

For the next few days I remained at Yokohama, writing letters, arranging my purchases, looking over my note-book, and making myself more thoroughly acquainted with certain manufactures. On the morning after my arrival I had a welcome visit from Mr. Saumarez, who had been the genial companion of the first part of

my journey. On one of the days spent at Yokohama we had a steady downpour of rain from morning to night, and part of another day was also wet; but we must now look for rain, for the wet season is approaching.

On March 25, having done all that was needed in Yokohama, I left by the train for Tokio, where I remained for two or three days, calling upon my old friends and inquiring into one or two matters which I do not yet understand.

The day following my arrival I spend in studying the shrines of Shiba. Dining with Mr. Saumarez in the evening, I met Mr. Sato, the great Japanese scholar, who has got back safely from Satsuma, where he was on a holiday when the rebellion broke out.

The next day I spent in arranging in the glass-cases of the museum the objects which I brought out from England. Mr. Mounsey introduced me to Mr. Ninagawa Noritané, an antiquarian of great learning, who is publishing an archæological work on the pottery of Japan. He first shows us some rude pottery from the early tombs, which he regards as two thousand five hundred years old, then a piece of green ware nine hundred years old, which he says was the first glazed ware of Japan. Bringing out some little brown jars, such as are used at the "tea ceremony," he told us that these were first made seven hundred years since. The first blue-and-white ware was made, so he tells us, in Japan in the fifteenth century. A rough, black Corean earthenware, which has a pattern scratched upon it, he pronounced to be fifteen hundred years old. He also tells us that a portion of a large, rude Corean pot, which has its border covered with lacquer-work, was made one thousand one hundred and fifty years since; that an orange-red lacquer tea-cup, which looks almost new, and a piece of aventurine lacquer, have been in existence nine hundred years; and that a piece of plain gold lacquer, which has flowers drawn upon it in fine black outline, is twelfth century work.

He now shows us a cabinet bearing a pattern formed of feathers, in oxidised silver and gold (like a box which may be seen in the South Kensington Museum). It was made for a prince whose favourite pastime was hawking: a fashionable amusement



with Japanese nobles and courtiers about three hundred years since. All the Japanese wares which are decorated with hawks' feathers were made for this prince or his friends. The crests of this family consist of hawk's feathers variously arranged; some bearing a very close resemblance to the three feathers of the Prince of Wales.

In the evening I was introduced to Mr. Matsugata, the vice-minister of finance and the president of the agricultural board, a pleasant gentleman, shrewd and intelligent. Two years later I renewed the acquaintance now formed in Paris, as Mr. Matsugata was sent by the Japanese as their commissioner at the International Exhibition of 1878, where I was acting as a juror. After this I also had the pleasure of showing him some of the most important manufactures of England.

## CHAPTER VIII.

A Shinto festival—Nikkô—The great Sanctuary—Arrival at Tokio—  
Japanese reports and police supervision.

*March 28.*—At 7 A.M. we started for Nikkô with Mr. Saumarez, turning aside, when some distance on the road, to see a shrine which throws considerable light on the nature of Shinto. About noon we crossed a river, came upon some priests with their singular robes, and bearing on their shoulders a kind of enclosed bier. This, we were told, contained a sacred mirror: a copy of the one preserved in the great shrine at Kamiji-yama in Isé.

At the next village which we reached a great Shinto festival was being held. Thousands of people were laughing and shouting and following an immense car, something like that of Jaghanath in India. On this car is a platform surrounded by a low railing, while in the centre rises a mast about thirty or forty feet in height, from the top of which fly the cut papers which symbolise the Shinto religion, while around its lower portion a tent of red and white cloth is suspended from a hoop. On the platform are musicians making rude music with gongs and fifes, and a masked actor, whose gestures would not be tolerated in England. The staff of this actor is unmistakably phallic.

He appears alternately as a man and a woman,—changing his dress in the tent of which we have spoken; and the car is dragged by hundreds of men and boys, who delight in pulling at the numerous ropes attached to it.

We are here brought face to face with what has long since

disappeared from the greater portion of the civilised earth ; yet the dragging of the car and the lewd symbolism are part of a religious service which is here regarded as of great moment ; and before the car the priests solemnly bear the sacred ark, which contains that strange emblem of Shinto—the mirror. The car itself is an offering made by the people to the gods, and they are now taking it to the temple.

It seems that, since foreigners have been permitted to enter the country, such ceremonies have been shorn of many of their characteristics : symbols have been reduced in number, while the processions themselves are now of but rare occurrence.

To me, the accidental meeting with this procession has been a matter of great interest, for it enables me to understand many things that have hitherto been incomprehensible. Proceeding on our journey, we spent the night at Koganai.

By 8.30 A.M. we are again on our way, and at 3 P.M. arrive at a small phallic shrine, over which the Shinto emblem flies. It is a diminutive temple supported on a pedestal. Around it are many stones varying in height from ten inches to two feet, and in diameter from two inches to five : the older stones are well cut, the newer are more simple in character. At 5.30 we reach Nikkô, having run for forty miles through an avenue of coniferous trees. For the last ten miles the avenue has been formed of magnificent cryptomerias a hundred and fifty feet in height, and with overhanging branches locked together in a vast vault.

Nikkô is a small town situated in a richly wooded dell. It has a mountain river leaping down a rocky defile, and a stream of delicious water flowing through the central street. Across the river, on the sides of a tree-covered hill, are the great shrines—the most important and the most beautiful of all the shrines of Japan—shrines as glorious in colour as the Alhambra in the days of its splendour, and yet with a thousand times the interest of that beautiful building. Here we have birds, flowers, water, clouds, carved in a manner that could not be surpassed.

Following the road beyond the hotel, we soon reached the mountain river, over which are two bridges, the lower open and

the upper closed. The closed bridge is painted red, and has locked gates at its entrance. These gates are opened only once

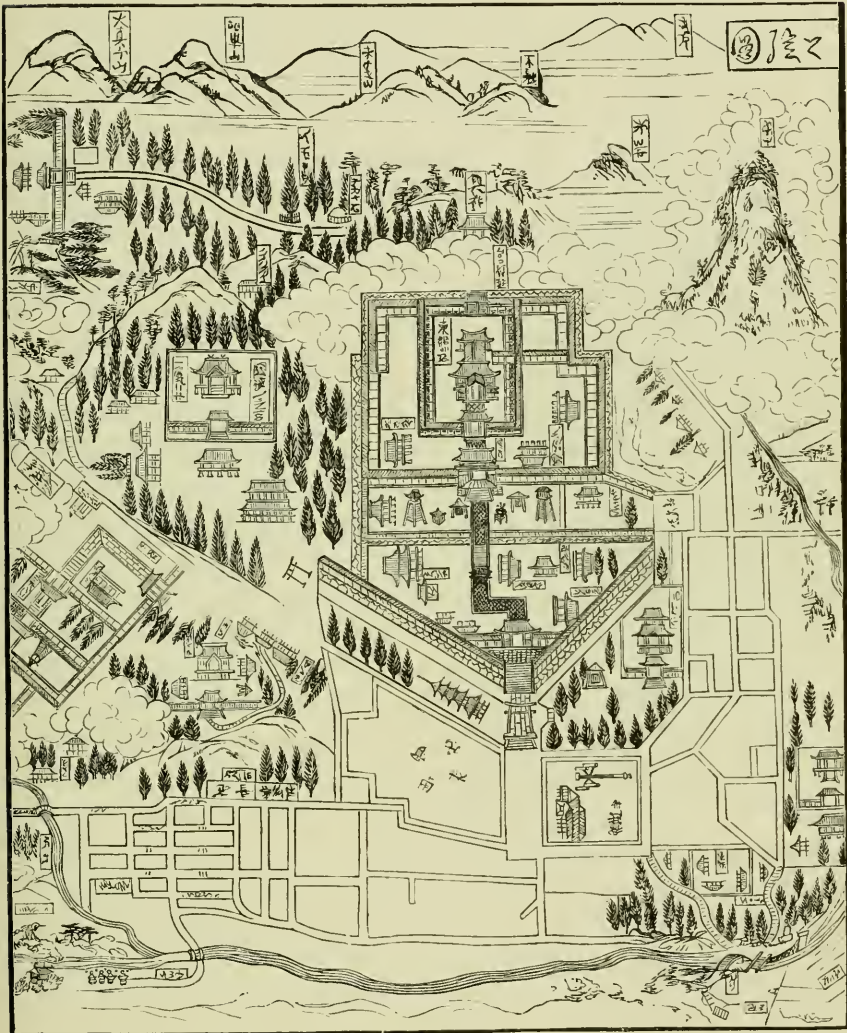

FIG. 65.—PLAN OF THE SHRINES OF NIKKŌ, AFTER A NATIVE CHART BOUGHT ON THE SPOT.

in a year (in August, I believe) at the time of the great pilgrimage to Nikkō. Turning to the left, and following the bend of the river for a quarter of a mile, we come to a phallic shrine of

vast proportions. But the Government has now passed an edict ordering the destruction of these emblems which for centuries have here found a home ; and throughout the country all such shrines are being dismantled. Continuing our course by the river for half a mile, and re-crossing the water, we came to some scores of stone

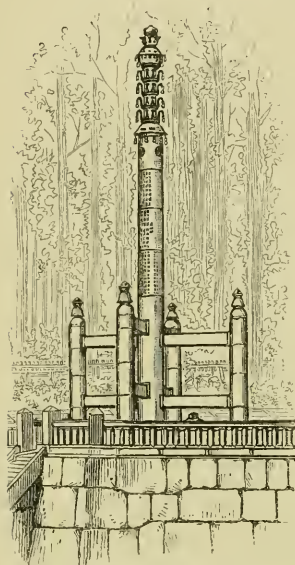

FIG. 66.—BRONZE COLUMN OR  
SORIN-TO AT NIKKO.

figures of life size, in sitting postures, which are said to be the disciples of Buddha. Ascending the hill behind these figures, we see a Buddhist graveyard, and near the water's edge a stone, over which rises a canopy supported on four stone columns. In a small indentation incense is at times burnt ; for on the face of an overhanging rock at the opposite side of the stream a Sanscrit inscription is cut, and the author of these characters is worshipped. After a glorious walk we returned, as night closed in, to our hotel.

In the morning we start early to see the shrines and temples so celebrated throughout all Japan. To do so, we follow the main street, cross the river, and then turn to the left as we did last night ; but, instead of continuing our course by the water, we soon turn to the right and ascend the hill on which the shrines and temples of Nikkô are built (Fig. 65). An opening at our right soon displayed a short flight of steps, on the top of which is a square flat enclosure, surrounded by a strong stone railing, in which there is a gate. Both the railing and the gate are of massive stone ; but they are mere copies in the harder material of a simple wood construction. Within this enclosure is a large bronze column supported by four buttress-like members (Fig. 66). In the central column are stored copies of the Buddhist scriptures ; and while the four supporting posts and the central column are here fixed, the whole structure is but a modification of the rotary

contrivance which holds copies of the scriptures, and the pious cause to revolve as a religious duty,—the sorin-to (so=all, rin=wheel, to=tower). The titles of the sacred books contained in this structure are written on the upper parts of the column in gold characters.

Continuing our walk up the hill, we soon reach a beautiful pagoda (Fig. 67) and various buildings, which together constitute the great sanctuary of Nikkô. These stand in an enclosure surrounded by walls, which are as beautiful as the buildings. These walls, like many in Japan, are roofed, and their lower portion is of stone, while intervening between the stone and the roof are uprights connected by tie-beams. The beauty of the walls lies in the carved panels, which fill the spaces between the uprights and the tie-pieces. Birds, flowers, clouds, water, and animals are here cut with a boldness which the finest of European carvers could scarcely equal. I doubt, indeed, whether we have in

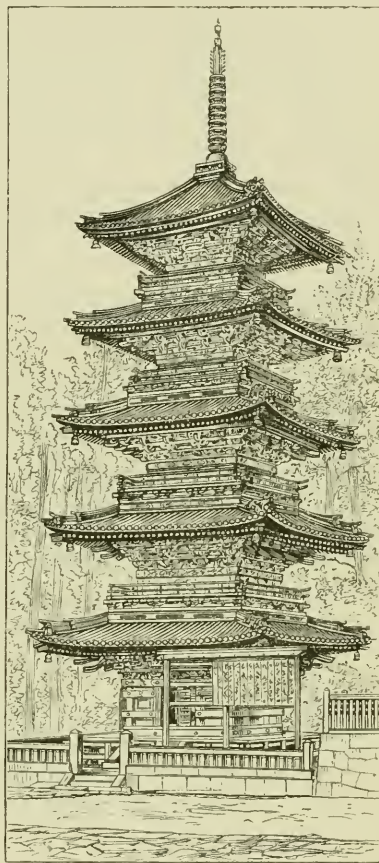

FIG. 67.—PAGODA AT NIKKÔ.

Europe any artists who could arrange such compositions with half the vigour exhibited in these panels (Fig. 69).

The temple enclosure is divided into a series of courts, one within, or beyond the other ; and as the shrine is situated on the side of a hill, which it gradually ascends, each succeeding court is higher than the one preceding it ; and the main building, being in the last and most sacred enclosure, is on the highest ground.

Here, on our left, is the stable in which a sacred horse was formerly kept, a building which strikes me as of great interest, and is formed chiefly of plain unvarnished timber. It has a few panels carved and coloured with consummate skill, while the distribution of these enrichments is as judicious as the carving and the colouring are clever. The coloured carving and a bold lattice door of the finest black lacquer contrast with the plain wooden structure in the most delicious manner. In this enclosure, and still on our left, are a series of buildings, any one of which is an object to boast of; and, if situated in any part of Europe, thousands would make long journeys to see it. There is the water tank standing under a canopy, which is a mass of beautiful work. The roof over it rests on twelve monolith columns, the tops of which, as well as parts of the horizontal tie-members, are encased in bronze sockets, diapered with fine patterns, and bearing the Shôgun's arms. Here and there, extending beyond the bronze encasements, are little bits of polychromatic ornament most carefully disposed. Above the horizontal member, and supported by a series of curious, yet characteristic brackets, is a wonderful, massive, sweeping roof, with rounded gables, borne on beams half enveloped in gilt metal figured with rich *repoussé* ornament.

Above the horizontal member and below the glorious sweeping roof, is a mass of carving, painting, and hammered metal-work, the like of which no English building can boast. Here we have water, almost lashed into tempest, with water-fowl riding on the waves, and flowers treated with exquisite tenderness, while all is subordinated to a true architectural position.

But in dealing with a shrine like that of Nikkô, words are altogether inadequate: even the best photographs give but an imperfect idea of buildings which owe half their beauty to colour, and half to form. Without the aid of either, and having to satisfy myself with a few woodcuts, which are as far behind the great photographs of Nikkô now before me as photographs are behind fully-coloured drawings, I feel that my attempt at conveying to the reader any fit conception of the beauty of these shrines must result in failure.

Next to the water-tank, and a little beyond it, is another building of great beauty ; but were I to attempt descriptions of the various buildings here congregated my book would swell to unwieldy bulk.

In the court now entered are several other buildings, and a series of lanterns, both in stone and in bronze. Most of these latter are about six feet in height and of the usual pagoda form, while all around are vast coniferous trees crowded together, so as to form an almost impenetrable mass of green. On the right, however, of the court is a building which we must not pass without notice. The lower portion is formed of triangular logs arranged horizontally, and resembling in its construction the old building at Nara in which the Mikado's treasures are preserved. Above the portion thus formed and below the great overhanging roof we have an amount of work in the highest degree beautiful.

Dealing with the gable end, which faces us as we walk up this outer court, we have above the V-shaped logs a horizontal member, on which runs a "Greek key pattern" in all its purity. From this rise five circular uprights, crossed by another horizontal member, on which again occurs the "Greek key," while two of the panels thus formed are filled with lattice-work and two with painted decoration.

Passing upwards, we have a diaper pattern in the spaces between the columns, and a series of brackets supporting a horizontal and projecting beam. Here rises a king-post, which carries the ridge of the roof, and beside which stand, in full relief, two elephants at play. There are other members here which cannot be described,—carved pendants, metal ties, grand-headed nails,—while nearly all the parts are covered with diaper-work of the richest colour and cleverest construction.

Following the pathway, we now pass through a magnificent torii, the uprights of which are of stone, while the horizontal members are of bronze, on which is repeated ten times the crest of the Shôgun.

This torii has its vertical columns encased in bronze sockets, which rest on a plinth or base, and are perfectly Greek in



character, the usual Greek leaf ornament enriching the moulding which spreads from the column to the base. Passing under the torii, we ascend twenty steps and enter the second court, in which we have a series of buildings and some magnificent trees. At one side is the belfry, at the other the music-house, together with other small buildings, while distributed over the court are brackets, a huge candelabrum, and a monster bronze lantern, these latter being all of European (probably Dutch) manufacture.

On some of the buildings which bound this court, and face us as we enter it, are carved panels of great magnificence. The first of these panels on the left consists of the pæony and the sacred bird, or hon—which may be regarded as the Japanese phoenix—with its three young. Another consists of a grand treatment of the fir-tree, another of the *kiku* flower, the plant of which the Mikado's domestic crest is formed, and on which the hon is supposed to feed, and others of various flowers and birds, all treated with masterly skill.

Leaving this court, which is a long transverse strip of ground extending to the right and left of the central path, we ascend a flight of thirteen steps to a gateway in which are two colossal figures, the one at the right and the other at the left (Fig. 68). This gatehouse is of considerable height, and has a massive roof, while a large gallery surrounds it; but both the gallery and the roof are supported on a complex system of brackets, such as must be seen to be understood.

The elaboration of detail in this gatehouse is absolutely indescribable. There must be thousands of brackets supporting the gallery alone, while as many are employed in sustaining the roof. Here we have dragons in full relief by the score, kylins in almost every attitude, carved flowers, groups of figures, clouds, water, diaper-patterns, and ornamental compositions wrought by the chisel, drawn by the brush, or hammered up in metal; while the whole constitutes a mass, beautiful in its proportions, pleasant in its "quantities," correct in its structure, and a very world of colour-harmony. This is the most marvellous architectural work that I have ever seen, and days might well

be spent in considering it. The illustration (Fig. 69) is a rude attempt at expressing the contour and detail of this gateway as seen from the court which we are now about to enter.

Passing through this gateway we come upon a large court which surrounds, on three sides, that enclosure in which the temple itself is situated. This enclosure is separated from the innermost court, in which the temple stands, by a wall, in the centre of which is a gateway (Fig. 69), if possible, almost more beautiful than the one through which we have just passed. The base of the wall adjoining it consists of massive blocks of stone, from which rise uprights at the distance of about twelve feet apart. These are connected by horizontal members thicker than the uprights, and through which the uprights pass. The first horizontal member is about sixteen inches above the wall, and is itself some fifteen inches broad; the next horizontal member is about five feet above this, and of about the same width; then comes another horizontal member at a distance of about sixteen inches; then a regular roof-structure covered with tiles.

It will be seen that we have immediately above the stone base of this wall a series of elongated panels about sixteen inches in depth, then above these a series of panels of about five feet in depth, then another series of the same depth as those below, all of which are covered by a substantial tiled roof.

The lower range of narrow panels consists entirely of carved representations of water and of water-fowl; thus on the left of the entrance to the innermost court the panel consists of three ducks flying over water. The next consists of water and cloud, with a passing flight of small birds; the next of geese and water; the next of ducks and water, and so with the rest; while to the right of the gateway we have storks standing in water; next a flight of small birds and water; then a flight of ducks over water, and so on. Above these come the horizontal connecting beams, which are diapered with an hexagonal pattern, then the large panels intervening between the two horizontal beams. These are framed with black lacquer margins, having rich metal corner plates, and these framed panels fill the large spaces left between the uprights and

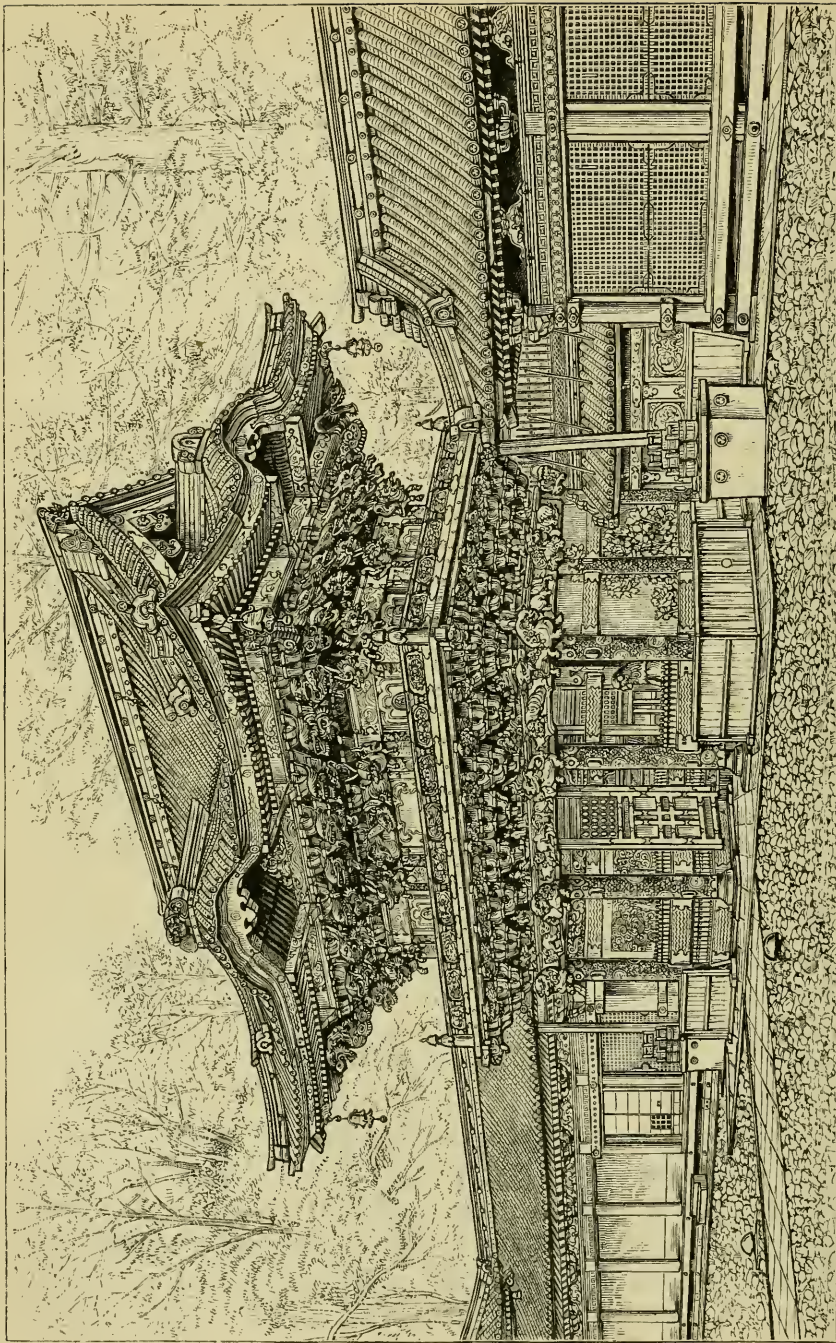

FIG. 63.—ONE OF THE GREAT GATEWAYS IN THE SHRINE OF NIKKO, SEEN FROM WITHIN.

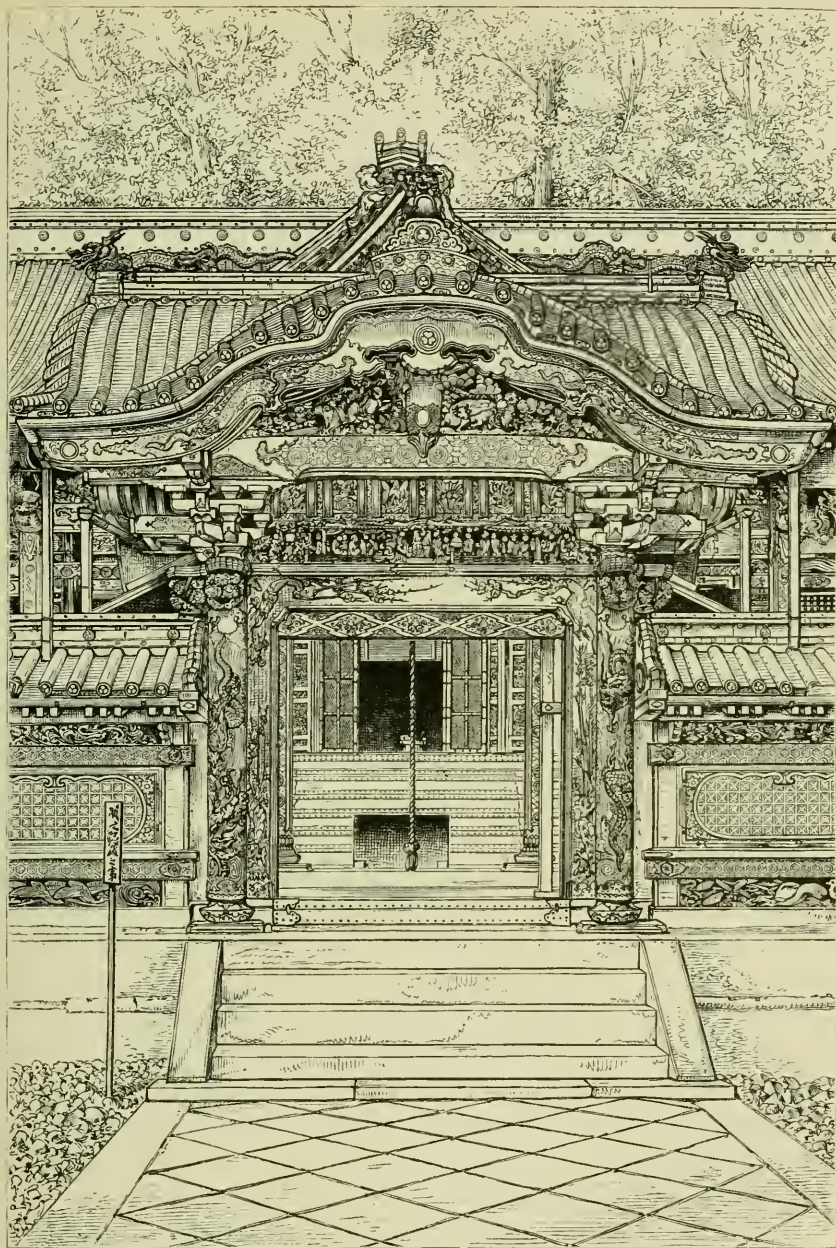

FIG. 69.—GATEWAY AT THE ENTRANCE OF THE INNER COURT OF THE SHRINE OF NIKKO.

the horizontal members. The panels themselves consist of pierced-work and richly-painted floral compositions. Now we come to the second horizontal members, which are again diapered with a hexagonal pattern ; but it should be noticed that this pattern laps over on to the upper and the lower surface of this horizontal beam. Above this comes the second series of narrow panels, which are filled with flowers and land-birds.

In the whole of these panels the subjects are treated with great tenderness ; yet there is a crispness and decision about the carving which is most masterly, while both carving and diaper-work are aglow with colours mingled in the most harmonious manner.

This court is surrounded by cloisters, and these are decorated with great simplicity, and in a manner that reminds me of Greek work ; yet there are decorative details which at once show that the work is not Athenian. The Greek key pattern is, however, used as a "string-course" on the walls as the Greeks used it.

Five steps lead to the gateway which forms an opening through this beautiful wall ; but how can I possibly describe a work that is at the same time full of detail, rich in colour, and most beautiful in aspect ? Round its outer columns entwine dragons which seem almost to live ; its architraves are covered with carved peach-trees in full blossom, the branches extending from the uprights over the lintel ; its brackets are tufts of chrysanthemum flowers, while above we have a series of horizontal members superposed one above the other,—the first giving us a very procession of gods ; the next a number of panels filled with charming arrangements of water-plants ; the next (a tie-beam) profusely decorated with ornament, and bound at its ends in elaborately treated metal sockets, and above all the other decorations, yet underneath the curious arched roof, are figures and animals and trees and water all grouped together with a perfect understanding of the laws which govern the distribution of ornament.

Ascending the five steps, and passing through this gateway, we reach the innermost court—a parallelogram with its length pointing up the hill where stands the temple itself:—a long

building of simple construction, but with carved panels of the richest character.

The temple is entered from a balcony surrounding it; and its sides consist largely of well-formed, and massive, lattice panels hinged at the top, and opening outwards. Above these window-panels we find rich carving. Internally, the temple has a ceiling divided into squares, like that of Uyeno, with a deeply coved cornice consisting of vertical lines; but the panels are filled with ornamental devices of appropriate character resembling those of Shiba.

I am getting weary of beauty, and can understand what Shakespeare meant when he said, "Sweet music makes me sad;" for surely there is an affinity between beauty of form, beauty of colour, and beauty of sound.

I now feel that sweet forms and sweet colours and sweet harmonies of colour are making me sad. I am also weary of writing of the beautiful, for I feel that any words that I can use must fail to convey any adequate idea of the conscientiousness of the work, the loveliness of the compositions, the harmoniousness of the colours, and the beauty of the surroundings here before me; and yet the adjectives which I have tried to heap one upon another, in the hope of conveying to the reader what I—an architect and ornamentist—feel when contemplating these matchless shrines must appear, I am afraid, altogether unreasonable.

We now leave the temple, and, making our exit through a quaint white gate (Fig. 70) proceed up the hill to a smaller, but not less beautiful, shrine. Here we find a strange anomaly, for the cut paper of Shinto dangles in a building radiant with colour and rich in ornaments.

Shinto enjoins the most perfect work, but employs neither

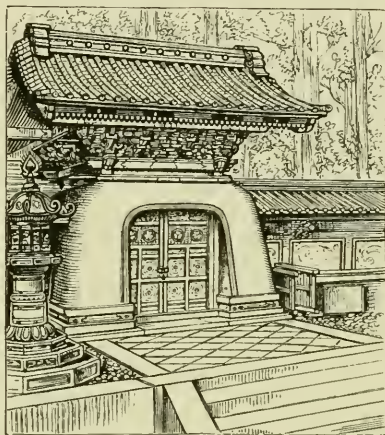

FIG. 70.—SMALL GATEWAY AT NIKKÔ.

colour nor carving in its temples ; while Buddhism symbolises by carving and colour the power of the Buddhists' god over all created things, and the loving protection which all that lives enjoys at his hands. The very essence of Shintoism is simplicity, and of Buddhism the tender perception of, and care for, all that lives. But the fact is—this shrine in which the Shinto emblem waves was Buddhist, and it is only since the revolution that it has been set apart for Shinto worship.

Connected with this temple are two rooms the columns of which are covered with gold with coloured decoration, in the form of folded drapery, at the top of each shaft (very similar to that in Figs. 82 and 87). The golden columns, together with horizontal members, divide the wall into panels, which have a margin of dark green diapered with gold. On this diaper-work falls a black lacquer frame pencilled with gold scrolls, while within the frame is a carving in unpolished wood of a vulture with a rabbit in its grasp.

When I first looked at this carving I thought that it consisted of one piece of wood, in colour resembling American walnut ; but now I see that the carved parts are of one wood, and the ground of another ; but the two are so similar in colour that they simply present two shades of one general hue. The wall consists of a series of such panels, only in each one the subject differs. Above these panels are horizontal members richly diapered ; then smaller panels, in which are coloured carvings or painted ornaments. The ceiling is divided into coffers, and every coffer has in its centre a carved group of flowers or ornaments in the natural colour of the wood. For a dining-room or library I can imagine nothing more quiet or richer in effect than this beautiful room at Nikkô ; and I only hope that some millionaire who can appreciate the beautiful will give me an opportunity of producing a similar room in this country.

This entire group of buildings, built for the purposes of Buddhist worship, have been ceded to Shinto since the restoration of the Mikado to temporal power. They contrast strangely, I need scarcely say, with the simple wood structures which constitute the shrines of that strange faith. There is, however, a smaller group

of temples close by which still remains in the hands of the Buddhists ; and the buildings here congregated are as beautiful in their decoration, and as rich in their details, as those of the larger series already described, while their situation is the better of the two.

With much regret I leave these beautiful shrines in the fading day and return to our hotel.

The manufactures of Nikkô are few. Sections of tree stems are here hollowed out as trays ; and are lacquered internally with a mottled lacquer, while the outside remains in its natural state. Trays are also made of a pliable bark, and sections of strange stems are prepared as kettle stands, very highly finished.

We resolved, although it was late, to get a few miles on our road towards Tokio before night. But no sooner had we started on our journey than snow began to fall and it became bitterly cold. The snow soon gave place to drenching rain, and we were compelled to spend the night at the little town of Utsunomiya, having made very little distance.

The next night at ten o'clock we reached Tokio, having run eighty-three miles in the one day. The weather has been fine but bitterly cold ; and the wind has blown a hurricane, overthrowing even large trees.

One thing only that I saw on the return journey is worthy of special note, and that is an apothecary's sign in the town of Satte. This sign was hung out in the roadway like those in front of our old inns ; but its character was most marked and interesting. It was of the form of the old gallows, but the tall upright shaft, the horizontal member at the top, and the bracket connecting the two were carved in a most perfect manner : indeed the carving on this sign was almost as elaborate and as clever as some of the work that we had seen in Nikkô.

The next day was spent at Yokohama in making preparations for my homeward journey, and on the day following I was entertained at a banquet which the ministers kindly prepared for me at the Hama Goten (strand palace, or summer palace of the Shôgun).



Going the next day to the museum, I found the things which I took out all nicely arranged in glass cases, similar to those at the South Kensington Museum, and here I met a number of the ministers, including Mr. Sano, General Saigo, Mr. Sameshima (who afterwards became the Japanese minister in Paris), and many others.

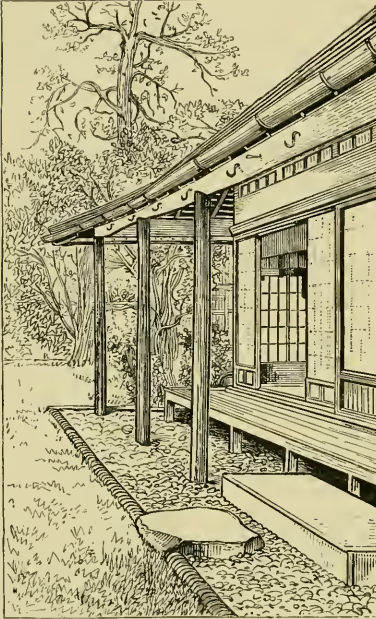

FIG. 71.—END OF PALACE IN THE HAMAGOTEN GARDENS, TOKIO. This Palace was formerly the residence of a Daimiô, then it became the summer Palace of the Empress, and now it is used for the entertainment of illustrious strangers.

After inspecting the objects in the museum, we drove to the summer (fishing) palace of the old Shôgun (Fig. 71), where an elaborate luncheon was prepared in the purest French style. Nay, not only was the cooking purely French, but on the table were costume-crackers and other bonbons, including those enormous contrivances which contain a full-sized dress.

Having bidden adieu to my friends, I started by the five o'clock train for Yokohama; Mr. Saumarez and one or two others accompanying me. At seven o'clock Mr. Sano, Mr.

Shoida (of the Tokio Museum), Mr. Ishida, and Mr. Sakata came to dine with me. At 9.30 Mr. Sano, Mr. Shoida, and Mr. Ishida left, while Mr. Saumarez and Mr. Sakata came on board to see me off; and to my astonishment General Saigo found time to slip away from the war office, although the Satsuma rebellion was at its height, to come and wish me a safe journey and again to bid me farewell. I am now on the steamship *Malacca*, and before morning dawns I shall be on my way to China. Thus ends my journeyings in Japan, during which I have travelled a little over one thousand seven hundred miles.

The following is a list of the distances that I travelled in Japan. But first let me mention that 1 shiaku equals 1 foot English (the Japanese foot is the same as ours, only it is divided into ten, and not twelve, parts).

6 Shiakus = 1 Ken.

60 Kens = 1 Chio.

36 Chio = 1 Ri.

(1 Ri is about two and a half miles.)

	Ri	Chio		Ri	Chio
Tokio in Musashi to Yokohama . . . . .	8	18	<i>Brought forward</i> . . . . .	366	16
Yokohama to Kōbe in Settsu	145	0	Kioto to Uji in Yamato and back . . . . .	12	28
Kōbe to Sumoto in Awaji . . . . .	14	0	Kioto to Ishibe . . . . .	9	0
Sumoto to Iga-mura and back . . . . .	12	0	Ishibe to Tsu in Ise . . . . .	18	23
Sumoto to Kōbe . . . . .	14	0	Tsu to Futami-ga-ura . . . . .	13	0
Kōbe to Santa in Settsu . . . . .	8	0	Futami-ga-ura to Nai-ku (interior temple) . . . . .	1	14
Santa to Shibe-yama in Settsu and back . . . . .	3	0	Nai-ku to Yamada . . . . .	0	30
Santa to Arima in Settsu . . . . .	1	18	Yamada to Yokkaichi . . . . .	18	0
Arima to Kōbe . . . . .	7	18	Yokkaichito Nagoya in Owari	12	27
Kōbe to Nara in Yamato . . . . .	23	0	Nagoya to Seto and back . . . . .	12	4
Nara to Kioto in Yamashiro	13	14	Nagoya to Tazimi in Mino . . . . .	10	18
Kioto to Osaka in Settsu . . . . .	12	12	Tazimi to Ichi-no-kura in Mino and back . . . . .	4	0
Osaka to Wakayama in Kii	17	0	Tazimi to Nagoya . . . . .	10	18
Wakayama to Kuroye-mura in Kii and back . . . . .	8	24	Nagoya to Toyohashi in Mikawa . . . . .	19	0
Wakayama to Ōta-mura and back . . . . .	1	24	Toyohashi to Kanaya in Tōtōmi . . . . .	22	0
Wakayama to Koya-zan . . . . .	16	2	Kanaya to Shidsuoka in Suruga . . . . .	9	0
Koya-zan to Okunoin and back . . . . .	2	0	Shidsuoka to Hakone in Idsu	21	26
Koya-zan to Hashimoto-mura	8	34	Hakone to Yokohama . . . . .	19	7
Hashimoto-mura to Osaka . . . . .	13	20	Yokohama to Kamakura . . . . .	6	0
Osaka to Kōbe . . . . .	10	0	Yokohama to Tokio . . . . .	8	18
Kōbe to Hiogo and back . . . . .	2	0	Tokio to Nikkō . . . . .	41	0
Kōbe to Tennō-ji in Osaka . . . . .	11	0	Nikkō to Tokio . . . . .	41	0
Tennō-ji to Kioto . . . . .	13	12	Tokio to Yokohama . . . . .	8	18
<i>Carry forward</i> . . . . .	366	16		685	31

Or about 1715 miles.

## CHAPTER IX.

A Japanese blue book—Object of my visit—Exportation of ginger—  
Manufacture of carpets, etc.

I HAVE now described my experiences while passing through a strange and interesting country; but while I travelled from place to place I little thought that all that I said or did was to be published to the world: but so it is. After the lapse of some months I received in London, a copy of a sort of blue book which had been printed and circulated throughout the manufacturing districts of Japan: and as this record seems to throw light on my journey I think it well to give translations of portions of this curious document. I also received about the same time a letter in English from poor Mr. Okubo, who was so brutally assassinated after my return to England.

This letter runs as follows:—

“INTERIOR DEPARTMENT, TOKIO, JAPAN,  
“26st of 3d month 11th year Meiji.

“DR. DRESSER.

“SIR—In January of last 10th year Meiji, you have brought the articles sent to our Museum, and I am much obliged that you have taken the trouble to arrange them. After your returning home last April, the articles have been exhibited to all the people, and I have notified all through the country your valuable informations, regarding to the important points of industry, which you have given to the officer who attended you during your visit to several industrial establishments. It must be for your kindness that I could make all industrial men to understand the points which were obscure heretofore, and I can assure you that in the future time they will make a progress and bring great interest upon the commerce.

“During your visit you have requested our Museum to make the models

of ornamental ceiling of several temples at Tokio, and now they have been finished.

“Although they are very trifling and not enough to compensate your last service, I present them to you, you will please accept them as the token of my highest regard.

“With compliment,

“OKUBO TOSHIMICHI,

“*Minister of Interior Department.*”

It thus appears that Mr. Ishida and Mr. Sakata were instructed to note all I did and said, and to furnish a report of my doings to the Government: and so minute is this report that the exact sum expended in the purchase of various objects is noted, and the amount of certain subscriptions which I gave to temples named.

The report first explains who I am and my motives for visiting the country. Thus it is said:—

“The purpose for which Dr. Dresser came to the East was to inspect the productions of Japan and China, and to find out their prime cost; moreover, he wishes to collect paintings and drawings, patterns on woven and dyed goods, and pictures of decorative colourings and sculptures on the temples and other fine buildings in the interior of Japan. Hence, in his travels in the interior, he collected porcelain and Japanned wares in which were preserved old patterns, woven goods both old and new, decorations of temples and other fine buildings.

“In his task of collecting old and new patterns and colourings, Dr. Dresser gave special attention to the ancient works of Greece and Rome in Europe, and in Asia he did not even omit the interior of India, sending agents where he could not go himself. He has now accomplished, after much labour and great perseverance, the design of many years, setting apart a sum of 180,000 yen of his own money for this arduous undertaking. He was especially satisfied with Japan, where he obtained many old and new patterns and articles of the highest interest.

“Having an extensive knowledge and fine taste in matters relating to the fine arts, Dr. Dresser was extensively consulted as a very good authority by various companies engaged in manufacturing porcelain wares, bronze articles, woven goods, etc., about their patterns and colourings. The sums which he received by way of remuneration from these companies suffice to pay his expenses. The costs of his Oriental travels were also borne by various companies, so that he felt himself bound to find out something important by which these companies might be benefited in their various industry.”

This is the Japanese notion of the object of my visit to the East : and while there is a good deal of truth in it, it also contains many facts altogether new to me. The manner in which my position as " Art adviser " to some of our leading manufacturers has been misunderstood is laughable, but I need not go through the various statements and say which are true and which are not, as my readers can almost judge as to this themselves.

In this report I am represented as giving information on seventy different subjects. Among these are :—

" EXPORTATION OF GINGER.

" The quantity of ginger used in London is very great indeed, being used in bread of higher quality, sponge-cakes, sweetmeats, etc., and also as medicine. The people of the city are very fond of it, and it has now, like tea and coffee, become almost indispensable. Now ginger does not grow in England, but is imported every year from the West Indies. As the quantity of ginger grown in Japan is very large, if its exportation were begun it would soon form an important staple. For exportation it ought to be cut into thin slices, well tight, and not liable to be spoilt."

This is an admirable illustration of the general character and nature of this report. The conversation on which this paragraph is founded arose in the following manner.

Being present at a Japanese meal, with one course of which (fish) shredded ginger was served as we serve horse-radish with beef, and noticing that the ginger was fresh from the ground, I asked if it grew abundantly in Japan, and was informed that it did. I then explained that it was a valuable article of commerce in Europe, and that it might probably be advantageously included in the exports of the country.

Being asked the uses to which ginger is put in Great Britain, I said that it was used in medicine, as a flavouring in confectionery, and that a certain kind of cake, called ginger-bread, in the making of which this article was employed, was enjoyed by our children. Now we can quite understand how our term " ginger-bread " has come to be " bread made of ginger ;" but why sponge-cakes should have been selected as illustrations of the use of this pungent rhizome, or why the city of London should have preference over

other places as the seat of its special consumption, I cannot say ! The notion of the cutting of ginger into thin slices must have been suggested by a knowledge of the fact that the Americans slice apples in order to dry them.

Now for my description of the

“ MANUFACTURE OF CARPETS IN LONDON.

“ The manufacture of carpets generally is like that of velvet, only the threads and wires are longer. There are four kinds now manufactured in London, England ; each manufactory makes one kind, and the quantity manufactured is very large indeed. As the warp is treble in velvet, so in carpet weaving warp is from treble to quintuple, according to the fineness of the pattern and texture. The quintuple warp is used for very fine pattern, and the stuff is very thick.

“ The finest style is called the ‘ Walton.’ In this method the wire put in is provided with a sharp knife-edge at one end, so that in taking it up it cuts all the threads put lengthwise, being like the velvet.

“ The next is the ‘ True Axminster,’ and the method is like that pursued in the manufacture of the highest quality in Sakai Ken. In this method each thread of the warp consists of threads of proper length of various colours tied to each other, so as to form the figure required, woofs being put in gradually. But as the process takes a long time, only those of best quality and high price are manufactured.

“ The third style is the Templeton Patent Axminster, so called from the inventor. In this the patterns are, like that of the wall paper, repeated over and over again. Several breadths may be put together so as to form a continuous figure, according to the size of the room. This method is very simple and good. The price is about five dollars (twenty shillings) for a square yard.

“ The fourth is the Tapestry carpet. This method is very simple, and differs from the above three. The method of dyeing the warp and woof is very speedy. Before they are put on the weaving machine the threads are placed in the order in which they are to be woven, and put round a large cylinder on which colours are put in proper pattern. As the cylinders roll in contact the threads on the first cylinder are dyed in proper colours. This is the point in which the method, which is very quick and convenient, differs from the first three.”

This is put forward as my description of the carpet manufactures of England.<sup>1</sup> First, the seat of this industry is said to

<sup>1</sup> For a description of the carpet manufactures of England, see the section on this subject in *British Manufacturing Industries*, by the author.

be London, where, until Mr. Morris erected his few handlooms on Chiswick Mall a short time since, no carpet loom has for many years existed. The description of the processes of manufacture, and the kinds of carpets produced in Great Britain, is a strange jumble indeed!

Next comes a paragraph entitled

“THE CARPETS AND FURNITURES OF EUROPEAN MANUFACTURES  
ARE UNFIT FOR A JAPANESE HOUSE.

“During my sojourn in Japan I observed the carpets, porcelain, and other articles all of European manufacture, in every house everywhere. All these articles are made for the use of the people of the lower class in England, and are never used in the houses of the middle class. Moreover, European merchants, finding that they can get the largest profit on these cheap articles, send inferior goods to Japan. I am very sorry to see many perfect houses of the Japanese style spoilt and deprived of their own excellent characteristics by the presence of these inferior articles. Moreover, Japan is a very productive country. Carpets are made in Osaka, Sakai, and some other places: and many fine and noted porcelain wares and furnitures are manufactured here. Therefore, if the houses are furnished and decorated with their home-manufactured articles, the admiration and wonder of Europeans who may enter these houses will be much more deeply excited. The people of all nations are unreasonably prejudiced in favour of the foreign articles, and care little for home productions. This feeling seems ingrained in the brain of people. And it may be justly said that the foreign merchants get profits only by availing themselves of this feeling.”

This last paragraph has arisen out of certain remarks which I made respecting the furniture seen in the houses of one or two Japanese ministers, for, undoubtedly, these worthy gentlemen had been considerably imposed upon by foreign traders, as most European articles in their houses are of the very commonest description, and such as scarcely make their way into the residences of the lower middle classes in England. But how a statement to the effect that “I observe the carpets, porcelains, and other articles of European manufacture in every house, everywhere,” can be accounted for, I am at a loss to know.

Next we are favoured with my opinion on the

## “MANUFACTURE OF HARDWARE IN OSAKA AND SAKAI KEN.

“Very good hardwares are made in Osaka and Sakai Ken. Now, in London such machine-made pieces of domestic furniture as have been manufactured in Europe, and are smooth and polished, are not regarded with favour. At present handmade wares, not highly finished, with hammer marks shown, are becoming generally popular. This is one reason why it is important that Osaka and Sakai should export articles likely to suit the wants of the London people. But the wares which can answer to these wants are of course not of many kinds; and as every house in that city has fireplaces, stove, with the accompanying tongs and pokers, these tools should be made by hands without using machinery, by the Japanese method—simply, without ornaments, and so as to show hammer marks; it is certain that they will be generally esteemed in London. Again, if the hardwares fixed on the doors in the temples of Osaka, Kioto, and Nara, be imitated, with hammer marks apparent, and in the same colour, they will be greatly in request in London. There is no doubt that although manufacturers in that city may attempt for a time to imitate the furniture sent from Japan, yet, as they will work at a much greater cost, articles of Japanese manufacture will be sure to be more in demand.”

The composition of this paragraph is more easily accounted for. It arose out of a conversation respecting hardware, in which I mentioned that persons of artistic taste in England preferred black hammered fire-irons to the highly polished productions of Sheffield.

The next paragraph that we select is the most important in the report, as it sets forth, in a way, my appeal on behalf of the temples and ancient monuments of Japan. It is headed—

## “ABOUT THE OLD TEMPLES OF KASUGA AND TODAIJI IN NARA, YAMOTO.

“Yamato is the most noted province of Kinai (five provinces about Kioto). In Nara, especially, as being the seat of the ancient capitals, there are still to be seen many buildings and works of art from which the splendour of ancient times may be clearly imagined. European antiquarians in treating of long past ages always proceed on evidence furnished by what remains in ancient towns, such as temples and other buildings, and are very careful to preserve the ruins as long as possible. Now, Nara, as a place full of old ruins and relics over one thousand years old, is of highest importance to all who study the conditions of ancient times. It is desirable that the Government should protect and preserve carefully an ancient place like Nara. The dance of Mikanks (a sort of priestess) at Kasuga Temple is worthy of praise as preserv-



ing much of the old simplicity. Among the old articles in the treasure-store of Shozo-in not a single article is to be seen that is not of the highest value and interest, and which may not help us to realise the conditions of old times and the splendour and excellence of ancient workmanship. How happy I was to have the opportunity of seeing all these old and valuable articles! In all my life I shall never have another such joy."

Now we come to a paragraph that shows some little want of knowledge respecting the manner in which custom-house duties may be altered.

" THAT THE IMPORT DUTY ON THE SAKI (JAPANESE SPIRITUOUS LIQUOR) OUGHT TO BE DIMINISHED.

" Since the opening of Japan a certain amount of saki has been imported into London; but as the price there is very high it is not sold in large quantities. The high price is due to the heavy import duty charged in England. Now, the rule of the custom-house in England is to impose a very heavy tax on the distilled spirit of alcohol, but only light duties on the others. Now, the custom-house officers look upon the saki as obtained by distillation and therefore impose a heavy duty on it; but I have now examined personally the method of brewing Japanese saki, and found out the mistake of the English custom-house officers. Having some influence at the custom-house, I will speak to the officers about it; but the quickest and the best way of having this altered is for the Home Department to write to the English ambassador explaining this matter, and have it countersigned by him and sent to the English Government. The Government will then give proper orders to the custom-house officers to alter their present course; and then the export of saki will easily be increased.

" The author says: 'The middle and lower classes of Americans in every part of the United States like "volatile liquors." Japanese saki has this quality in a high degree, as that it is sure to meet with much demand in America.' Dr. Dresser, struck by this fact, has entered into contracts for the export of the Japanese saki, intending to send it to Tiffany Store in New York City, to try its sale. Tiffany Store has advertised already that it has received Japanese saki from Dr. Dresser, whose sharpness and judgment in commercial affairs cannot be too highly admired."

This extract is certainly choice in its way. Saki is (as I knew long before my visit to Japan) a colourless beer, and not a spirit, as it is produced by fermentation only, and not by distillation of a fermented fluid. It is therefore not chargeable with the spirit duty. As for Americans liking "volatile liquors," and saki having the quality "in a high degree," and my making a contract for the

export of this exhilarating fluid to the great silversmith of New York, I can only say that only from this report did I learn that I had achieved this important business arrangement. I certainly had the honour of being intrusted by Messrs. Tiffany and Co. with the choice of any objects that I might think calculated to aid in the development of their silversmith business; and it is interesting to me to know that, after a careful and most intelligent consideration of these objects, Messrs. Tiffany and Co. produced new works which secured to the firm the "grand prix" at the last Paris exhibition. Whether amongst the things sent there were one or two bottles filled with saki or not I cannot say; but this is the alpha and the omega of my dealings in this alcoholic beverage.

The business astuteness with which I am credited is, perhaps, borne out by a small section of the report, in which I am represented as expressing my opinion on "Perseverance of Mind," and "That it is profitable not to gain much interest on articles of sale."

#### "PERSEVERANCE OF MIND.

"Innumerable are the persons in every country who, either as individuals or in companies, undertake to produce any articles in a large scale for extensive sale, and who fail at the outset of their career owing to the deficiency of profit to balance the expenditure. The cause may be explained as follows:—Such persons stop short too soon through fear of losing not only the capital but also of incurring fresh losses from the deficiency of profit to balance the outlay needed to keep up the business. Intelligent persons, however, in such case never stop so soon. They look after the management of their undertakings. They are careful to see whether unnecessary hands are employed at work, and, if it be so, to have these extra hands got rid of. Again, the materials for the production of articles required may be too expensive, and in this case they have them bought cheaper by some means. After many years' experience they may succeed in producing good articles and gradually enlarging their sale. This success entirely depends on the endurance and energy of the persons concerned. The interests of all the traders in English manufactures suffered from these causes when the methods of modern manufactures were first introduced. When cheese was first manufactured in America it was sold at the low price of five cents per pound. It is evident that this will not pay for the expenses of production. But its quality is now so much improved that it is sold at twenty cents per pound. The cheese manufactured in Europe is sold

at sixty-two cents per pound. Hence the amount of American cheese imported to England increases year after year. This success is the result of the efforts of many years in America."

"THAT IT IS PROFITABLE NOT TO GAIN MUCH INTEREST ON  
ARTICLES OF SALE.

"There is what they call the commission of *Toi-ya* (an establishment where articles of all kinds for sale are deposited and distributed). According to what I have heard of it, the commission is ten per cent on the value of the articles, and it is exacted by *toi-ya*. At present in China this commission is only one-sixteenth part on the value of the articles. The Japanese production being too costly, its price is increased in proportion, and the consequence is a diminution in the amount of exports. The secret of carrying on national manufactures at a profit lies in producing cheap articles at small profits, and in largely increasing the amount of exportation. There was one trading company in England which dealt in carpets, but few were purchased on account of the dearness of price. The high price was charged to balance the expenses of the establishment. The company was going to dissolve when one member urged another course. He reformed the rules of the company, and sold carpets without any profit, but lessened the size of carpet by only three longitudinal lines when compared with the carpets hitherto made. With the profit thus arising the company worked on. The lowering of the price brought an increase of customers; and the company not only exists still, but prospers. The postage of England also differed proportionally with the distances. The postage for the most remote parts of the country was fixed at one shilling, and the people felt it inconvenient to pay so much. Thereupon the Government changed the established regulations of postage, and determined that the postage within the English dominion, distant or near, should be a penny. On that occasion there was one who protested that the Government, by making this change, would find itself involved in unexpected expenses; but after the change the people felt its convenience, and the number of postage stamps was doubled. The revenue of the post-office increased manyfold. From these two instances it may be seen clearly that cheapness insures an increase of profits. Nor can it be doubted in trade generally that the interest of the trader lies in selling his commodities cheap and in large quantities."

These wonderfully erudite disquisitions on the principles that govern the success of companies will fully account for the flattering remark contained at the end of the preceding paragraph.

Now we have a series of paragraphs which profess to set forth my opinion of the various potters' wares and manufactures seen during our journeyings. One finishes with this passage:—

“ In London ladies and old ladies take great fancy to tea-cups and such things. Those above the middle class indulge in purchasing silver trays; therefore, such trays manufactured in Japan as having gold and silver inlaid, and which are not easily defaced, might become the rage of old patronesses. Beside this, iron frame of fan, inlaid with gold and silver, might suit the demand of genteel class.”

I will trouble my readers with only one more extract from this curious document. This I give because the information contained in it concerns us all, inasmuch as it reveals the means by which happiness can be secured. It is entitled

“ ON THE HAPPINESS OF THE PEOPLE OF THE INTERIOR PARTS OF JAPAN.

“ I have travelled about the interior parts of Japan for many months, and observed that the people's disposition is quiet, and everywhere they seem to be contented with their humble vocation, and show no signs of poverty. According to what I have heard they live in their own houses, and it is very rare to find men and women beyond the age of twenty unmarried. This deserves much praise, for marriage is the most important affair of one's life; and one who succeeds in perfecting the union is sure to derive happiness. Therefore, I should say that when the Japanese people are compared with Europeans, their happiness far exceeds that of the latter. In England, the people below the middle class have no houses of their own; and more than the half of this class cannot marry, even when they attain to old age. They work hard, yet they cannot escape poverty, or even meet their daily wants. In the eyes of such people a country like Japan might well seem a land of happiness. But for developing all arts, and making them a vast resource, the English are well adapted. But for encouraging so happy a people as the Japanese to improve their industries, some special modes of direction must be devised.”

It must always be borne in mind, in dealing with translations from one language to another, that difficulties may arise through the idiomatic form that expression takes in the different languages, and that the translation of technical terms is sometimes almost impossible. This would be especially the case where our manufactures were described, as a country like Japan, which is almost without machinery, would not have in its language equivalents of our technical terms. But supposing the Japanese translator succeeded in conveying to his countrymen the meaning intended, it is almost certain that the translation re-translated into English would be so changed as to be almost unintelligible.

I must say that I found my good friend Sakata, so far as I could judge, an excellent interpreter ; and when I explained the nature of our manufacturing processes he always seemed to make the person to whom I talked understand what was meant. But it is one thing to explain a new process of weaving to a weaver, or a new process of printing to a printer, and a very different thing to make a person who knows nothing of a process understand its nature.

Sakata had but little knowledge of manufacturing processes, and both he and Ishida laboured under this great disadvantage that they could but seldom have recorded my remarks and explanations till some time after they were given, even had they wished to do so. But as it was evidently not intended that I should know that this report was being prepared, the difficulty of making an exact record of what occurred was greatly increased. Besides this, Sakata, sometime after he had heard my explanations, translated them to Ishida, who, in the absence of the little drawings that generally accompanied such explanations, would probably fail to understand what was meant.

This will account for some of the eccentricities of this report. Such a mistake as that which describes "bread of high quality" as made from ginger we can understand, for our term "Gingerbread" would be most misleading to a foreigner. We must make every excuse for a document such as the present ; but if this rendering should fairly represent the Japanese document, I fear that its publication is likely to mislead the Japanese seriously, and to injure my reputation ; for in such explanations as that of the carpet manufactures, any one having the most rudimentary knowledge of the processes by which carpets are made, could only think that I was trying to deceive the Japanese rather than to instruct them.

## *PART II.*

### CHAPTER I.

IT has been said that "architecture is the material expression of the wants, faculties, and the sentiments of the age in which it is created," and that "style in architecture is the peculiar form that expression takes under the influence of climate and materials at command." It has also been asserted that "the influence of the causes which act most powerfully on the genius of the Arts, after the climate, is the manners, religion, and the changes to which a nation is subject in its political state during the course of ages."

All who have studied the architecture of various countries must feel the truth of these statements. In Japan they are borne out in a most striking manner; for here we have a form of architecture marked by great individuality of expression, manifesting to a striking degree the nature of the material of which its structures are built, and owing its special features to the conditions under which it exists, and the religions with which it is associated.

Before we can understand the true nature of Japanese architecture, and of the arts which have sprung from it, something must be said of the religion of the country; and the knowledge gained from a study of the religion will enable us to comprehend the nature of many ornaments, as well as the reason of many striking architectural features.

There are in Japan two religions—the Buddhist and the Shinto. The former was the religion of the now dethroned Shōgun, and the latter of the Mikado. As the Shōgun was the temporal ruler, and appeared in public, the religion which he professed had magnificent shrines and temples of great beauty. But as the Mikado up to the year 1868 was kept in seclusion, and never allowed to pass outside the walls of his simple palace, the religion of which he was chief was somewhat neglected. The Shinto temples were few in number and small in their proportions when compared with the magnificent shrines devoted to the service of the Shōgun's faith.

The Shinto religion is undoubtedly a very early form of worship, and is of most primitive character. Europeans have been much puzzled with its tenets, and have in some cases altogether misunderstood them; yet I cannot help thinking that much of the mystery with which they surround it is entirely of their own creating.

This religion was called by the Japanese *Kami-no-michi*, which means,—way, or doctrine of the gods—theology. The Chinese form of the same is Shinto, and this expression has been generally adopted in Japan for the national religion. But for centuries Shinto has become modified through contact with Buddhism, and but few temples now exist which have preserved its ancient purity.

In his excellent work on Japan,<sup>1</sup> Griffis tells us that in Japanese mythology the universe is Japan, while the Mikado is the descendant and representative of the gods who created heaven and earth (Japan); hence it is the imperative duty of all Japanese to obey him.

He then goes on to tell us of the nature of Shinto, and says:

“The chief characteristics of Shinto are worship of ancestors and the deification of emperors, heroes, and scholars, also adoration of the personified forces of Nature. It employs no idols, images, or effigies in its worship. Its symbols are the mirror and the gohei,—strips of notched white paper depend-

---

<sup>1</sup> *The Mikado's Empire*, by W. E. Griffis. Harper Bros., New York,

ing from a wand of wood. It teaches no doctrine of the immortality of the soul.

“The native term for man is hito (light-bearer); and the ancient title of the Mikado’s heir-apparent was—‘light inheritor.’ Fire and light (the sun) have, from the earliest times, been objects of worship.

“The leading principles of Shinto are, imitation of the illustrious deeds of ancestors, and effort to prove themselves worthy of such descent by purity of life. It abhors uncleanness, and has rites and ceremonies for bodily purification. The priest must bathe and put on clean garments before officiating. He must bind a strip of paper over his mouth so that his breath may not pollute the offering; and the ground dedicated to a religious festival is first purified by salt. Outside every Shinto temple are large troughs for washing, the water being ladled from the trough and poured over the hands, and this washing is enjoined before the offering of prayer.

“In olden times the emperors and priests performed ablutions for the people. Later on, twice a year, at the festivals of purification, paper figures symbolising the people were thrown into the river as an allegorical representation of the cleansing of the nation from the sins of the past year.

“Later the Mikado deputed the minister of religion at Kioto to perform the symbolical form for the people of the whole country.

“Thanksgiving, supplication, penance and praise, are all represented in the prayers to the gods.

“Usually in prayer the hands are clapped twice, the head or the knees bowed, and the petition made in silence. The worshipper often does not enter the temple, but stands before it, first pulling a rope, which dangles down over a gong, so as to call the attention of the Deity.

“The kami, or gods, hear the prayers before they are uttered, and prayer is in silence. The Mikado daily offers prayers of special efficacy for his people. Offerings are laid with great ceremony, by priests in white robes, before the gods—as fruit and vegetables, fish and venison; at night they become the property of the priests. Game and fowl are offered as an act of worship, but their lives are not sacrificed. They are hung up by the legs before the temple for some time and are then set free. Being now sacred they are exempt from harm. This practice of offering fowls now appears to have ceased.

“Before each temple stood a torii or bird rest” (Fig. 39). “This was formed of two upright tree-trunks, on the top of which rested horizontally another tree with projecting ends; underneath this was another smaller horizontal beam; on this perched the fowls offered up to the gods as chanticleers to give notice of daybreak. In later times, as the practice of offering fowls has been discontinued, the use of the torii has been almost forgotten. As a Shinto erection, it was always of plain wood and consisted of right lines. The Buddhists, however, painted or coppered its posts, curved its top piece, made it of stone or bronze. The torii is a purely Japanese work,



“All the *miyas*, or Shinto temples, were rigidly simple—constructed of pure wood—thatched and no paint, lacquer, gilding, metal, nor ornament were allowed to adorn (defile) them.

“Within the temple, only the *Gohei*—or strips of notched white paper, and the daily offerings are visible. In a closet of purest wood is a case of wood containing the ‘august spirit substance’ or ‘god seed.’ This spirit substance is usually a mirror, which in some temples is exposed to view.

“The priests are of various ranks, some receiving titles from the emperor, the higher are court nobles and are strictly government officials. They dress as other people do, some wearing white robes, however, when officiating, or court dress when at court. They marry, rear families, and do not shave the head.

“Virgin priestesses also minister at the shrines.

“Many scholars doubt whether Shinto is a genuine product of Japan, regarding it as closely allied to the ancient religion of China which existed before Confucius. Many of the Japanese myths are almost exactly like those of China.

“*Motoōri*—the great modern revivalist of Shinto, teaches that morals were invented by the Chinese because they were an immoral people, but in Japan there was no necessity for any system of morals, as every Japanese acted rightly if he only consulted his own heart. The duty of a good Japanese is to obey the *Mikado* in all things without question; it is only immoral people, like the Chinese, who presume to discuss the character of their sovereigns. With the Japanese, government and religion are the same thing.”

This explanation of Shinto and its usages throws but little light on the true character of the religion, and there are one or two little particulars in which it is wrong, for we frequently find metal and even gilt metal, used in connexion with Shinto buildings. Even the great temples in *Isé* have certain of their parts encased in gilt metal sockets.

Satow says—“There is good evidence that Shinto resembles the ancient religion of China very closely. . . . The sword and the dragon, the thyrsus staff and ivy, the staff of *Esculapius*, and snakes most probably had the same religious significance as the Japanese *gohei*, and as *Siebold* has remarked, it symbolised the union of the two elements—male and female.”

The Rev. S. R. Brown says—“Shinto is in no proper sense of the term a religion, but has rather the look of an original Japanese invention,” while Sir Harry Parkes agrees with Satow in thinking that it reached Japan from the continent of Asia. Sir

Harry says—"The practice of putting sticks with shavings or paper attached in order to attract the attention of the spirits is observable among certain hill tribes of India, as well as among the Ainōs of Yezo (the northern island of Japan): the Hindoos, Burmese, and Chinese, have converted these sticks into flags or streamers."

I had many conversations with Japanese of the Shinto faith respecting their religion, and they invariably told me that prayers for help were never offered to their gods; and that it was a religion intended, primarily, to keep alive the sense of gratitude. At the shrines dedicated to their great benefactors—whether a warrior as Ojin the emperor, who was deified as the god of war, or the maker of a harbour, or the reclamer of waste ground—they offered thanks to the deified individual who had benefited the country. But upon being told that the immortality of the soul was not admitted by the believers in Shinto, I inquired why they wasted time in thanking an individual whom they regarded as altogether extinct, and who could in no way understand the nature of the homage offered. In reply to my question, I was informed that it was nice to keep alive the sense of gratitude, and that it was pleasant to offer thanks even to one who could not hear.

Summed up, Shinto consists of fire worship,<sup>1</sup> hero worship, and phallic worship,—three of the early worships of mankind.

<sup>1</sup> I cut the following paragraph from a recent issue of one of our daily papers :—

“RELICS OF FIRE WORSHIP.—On the last day of the year, old style, which falls on the 12th of January, the festival of ‘The Clavie’ takes place at Burghead, a fishing village near Forres. On a headland in that village stands an old Roman altar, locally called the ‘Douro.’ On the evening of January 12th a large tar-barrel is set on fire and carried by one of the fishermen round the town, while the assembled folks shout an holloa. If the man who carries the barrel falls, it is an evil omen. The man with the lighted barrel having gone with it round the town, carries it up to the top of the hill, and places it on the Douro. More fuel is immediately added. The sparks as they fly upwards are supposed to be witches and evil spirits leaving the town; the people, therefore, shout at and curse them as they disappear in vacancy. When the burning tar-barrel falls in pieces, the fishwives rush in and endeavour to get a lighted bit of wood from its remains; with this light the fire on the cottage hearth is at once kindled, and it is considered lucky to keep in this flame all the rest of the year. The charcoal of the Clavie is collected and put in bits up the chimney, to prevent the witches and evil spirits coming into the house. The Douro (*i.e.* the Roman altar) is covered with a thick layer of tar from the fires that are annually lighted upon it. Close to the Douro is a very ancient Roman well, and, close to the well, several rude but curious Roman sculptures can be seen let into a garden wall.”

On feast nights Shinto temples are surrounded by fires which seem to constitute an important element in the festival; and at Futamigaura we found pilgrims assembled to worship the rising sun, as seen between two rocks connected by a straw band from which the Shinto symbols are pendent. Here, then, we have the worship of fire and of the sun—the latter being the great source of heat, and the giver of heat to the world. Hero worship is everywhere manifest, and temples are erected to the great of all time. The manifestation of phallic worship—the mystery of the origin of life, is very conspicuous. But in a few years all outward symbols of this element of Shinto faith will be destroyed, striking and marvellous though they yet are, for the Government have ordered their demolition.

We have seen that the great emblem of the Shinto religion is a mirror. At the principal Shinto temples at Kamiji-yama in Isé a mirror is preserved in the most sacred of the buildings; the mirror having been brought down from heaven and given by Amaterasu to Ninigi; while imitations of this mirror occur in the different Shinto churches. It will also be remembered that we saw on the road to Nikkô priests carrying to a great festival an ark containing the mirror.

The mirror is said to symbolise the manner in which actions and thoughts should be open and visible; for as the mirror reveals our image, so our acts and thoughts ought to be capable of being revealed without our being ashamed.

This principle is rigidly carried out in the construction of every Shinto temple.

Every part of the edifice, whether seen or unseen, manifests an amount of honest workmanship which in its finish is simply perfect; and in no part of the building can we find slovenly work, however small or perfectly concealed the part may be. Here we have the very essence of Shinto, and an embodiment in spirit of that passage in our own Scriptures: "Whatsoever thy hand findeth to do, do it with all thy might." In Japan the principle permeates all society, and is carried out by the work performed in daily life.

In Japan Shinto is brought home to the people, be they of this faith or be they Buddhists. For centuries the Mikado has been regarded as the god incarnate of the Shinto Church, and as a being altogether too sacred for human eye to rest upon. In every house there is a little space, more or less cut off from the principal room, with a raised floor, and the end almost enclosed. On this raised dais the Mikado would sit should he ever visit the house ; and this niche has come to be associated in the Japanese mind with their gods. It is in this niche that household offerings are made ; and on New Year's Day I found a mass of dough, in the form of a cake, offered in each of these sacred enclosures. Usually a vase, containing a flower which is offered to the gods, and a censer, stand on the dais.

Were the Mikado to visit the house, the person serving his food would not see him, but would pass the viands through the opening at the bottom of the side partition.

There is this strange mingling of Shinto with the life of the Japanese people, whatever be their faith ; and even the Mikado, although the head of the Shinto church, offers prayers for the nation on certain occasions at a Buddhist shrine.

This little altar-like enclosure which we find in every house is constructed according to rule, and in it that finish is demanded which characterises all Shinto altars ; thus this royal enclosure gives a sort of keynote with which the whole house must be in harmony.

To me, it appears that we have here the cause, to a great extent, of the excellence which characterises most Japanese productions. This little altar gets loved. Offerings are made on it in seasons of prosperity. The flowers so much cherished are arranged in this sacred niche. Thus the Japanese have constantly before them a sample of excellent work, and this sample they have learnt from their early childhood to revere.

No one can have failed to notice that all good Japanese works, as well as most which are inferior, are as well finished in the parts that are unseen as in the parts that are seen. I have here before me a box which is carved all over, yet the best work is on the

bottom. Here is a tray, on the under surface of which is a spray as carefully drawn as the figures on the upper surface ; and here is a pot which has a pattern on the bottom as beautiful as that on the parts usually seen, if not more so. These are, however, somewhat exceptional instances ; but while it is not usual to find ornament on the bottom of a Japanese work, we yet observe that the finish of the parts hidden is equal to that of the parts exposed.

The decoration on the bottom of an object would seem to owe its origin to the fact that all persons receive pleasure from an agreeable surprise, and to the feeling, common to all Japanese gentlemen, that whatever is worn or whatever is used shall look simple and unpretending, and yet be worthy of most minute examination. A walking-stick which Mr. Yeno—the late Japanese minister to England—kindly gave me appears at first sight to be a mere rude hedge-stick ; but upon close examination it is seen to have most exquisitely cut metal insects creeping over it,—some being half buried in the bark, some crawling out of the little holes, and some running along the surface. Wooden netsukies, or large button-like ornaments, hanging from the girdle are preferred to those of ivory, because they are more quiet in colour and less obtrusive. But as gentlemen prefer the more subdued effects the wooden carvings are generally better than those in ivory. In writing-boxes on the same principle we generally find a much more lovely decoration inside the lid than on the top. But it is the excellence of the work, whether seen or unseen, that springs from the principles of Shinto, and not the surprises of which we now speak.

Shinto, so far as I could learn, has but little effect in producing love for nature. It causes adoration of the sun ; and it is from the sun that the warmth is derived which stimulates plants to growth and life. Also, without its genial rays no animal life could be sustained in the world. But it is to Buddhism we must look for that strange love of all created things which characterises the Japanese in such a marked manner !

Through the labours of Professor Max Müller and others we have become more or less acquainted with the nature of Buddhism.

I will content myself, therefore, with remarking that Buddhism in Japan consists of a number of sects (about a hundred and fifty), some of which are almost wholly spiritual, while others are utterly idolatrous.

A Buddhist will not destroy an insect or injure the smallest of created things. The child will play with the butterfly, but will not harm it ; and I have seen butterflies alight on children's hands. Birds are not afraid of man, for they have long since learnt to confide in a people that never hurt them ; and wild-fowl are as safe on the moat of Tokio Castle, although they are in the centre of a large city, as they could be if removed altogether from the abodes of man.

To me the love which the Japanese seem to have for birds, insects, and flowers, is most charming. There seems to be in Japan a harmony between man and the lower creatures such as I had never before seen ; yet there are peculiarities respecting Japanese affections which we ought not to pass unnoticed. While they love all flowers, the Japanese prefer those to which they have to look up,—as the flowers of trees ; and it is not uncommon to find in their illustrations poets kneeling under trees and looking up adoringly at the blossoms. The almond-tree is a special favourite, and for them it has especial beauty ; thus they compliment ladies by speaking of their “almond eyes.” The cherry is also a favourite tree ; but this is associated in the mind of many with pleasant picnics ; for, as we have seen, some of the happiest excursions which the Japanese make are to cherry-covered hills where families congregate to enjoy a pleasant day. The almond is the flower of spring. The sacred bean (*Nelumbium*) is the flower of summer. The chrysanthemum is the flower of autumn. We have just seen that the almond typifies beauty, and we may add that the *Nelumbium* is sacred. Buddha sits upon the flower, and the Buddhist prays that he may have a lily in the world to come. The chrysanthemum is imperial, and bears the same relation to Japan that the rose does to England. It is also the chief of the seven favourite flowers of the country.

Such associations are common to man in all parts of the world,

and they must not be confounded with that love of nature which owes its origin to the religion of Buddha.

The two great facts now before us which concern our study of Japanese art are these,—Shinto, which has influenced the home of every Japanese for a long series of centuries, has stimulated the people to the most conscientious work ; and Buddhism has created a love for all natural objects. These two influences will account for many of those qualities which characterise Japanese works, be they temples, objects of utility, or ornaments.

Before we begin to consider Japanese architecture itself we must look at one or two of those circumstances which have always modified the architecture of a nation, as the climate, the materials at command for the erection of edifices, and the wants which have consequently to be met by the production of a building.

Although Japan has a considerable rainfall, the rain is almost exclusively confined to one season of the year (about six weeks, between the end of April and the early part of June), and this wet period is followed by a continuance of hot weather.

This is a general statement, but the climate is by no means the same throughout the whole of Japan. In the central portion cold is intense on some winter days, while the heat is great in summer ; but the long and severe frosts of the north are unknown at the Satsuma end of the country.

The Japanese seek shelter from the rain, and they desire houses which give shade from the sun. They also require buildings which allow of the freest circulation of air. They are a hardy people, and can stand cold, and in the warmer season lead what is practically an outdoor life. At this period of the year, and indeed through most of the winter days, the window-like surroundings of their houses are removed, when all that remains is a roof supported on uprights.

But although a Japanese house is a building intended to afford shelter from rain and sun, the nature of the building is influenced by other causes.

Japan is a land of earthquakes. And this brings us to one of the most singular facts connected with the structure of Japanese

buildings ;—a method adopted with the special view of insuring safety during these periods of the earth's vibration.

Japanese houses and temples are put together in a solid and simple manner, each work being complete in itself, and having an altogether independent existence. Thus a Japanese house is in no way built upon foundations, or fixed to the ground on which it rests. It stands upon a series of legs, and these legs usually rest on round-topped stones of such a height as will, during the rainy season, support the timber uprights above any water that may lie upon the ground.

It is obvious that while an object fixed to the earth might, if rocked, be broken off from the ground or become strained and destroyed, that that which is loose would simply oscillate and settle down again after the cause of its vibration had ceased. For instance, we may cause a chair or a table to rock by jolting it, but in a very short time it will become stationary and will be uninjured ; whereas, were the legs fixed, the application of a small amount of pressure on the upper part (especially if the top was heavy), or any upheaving of a portion of the ground on which it rests, would be likely to injure or destroy it.

I am aware that much damage has occurred through some of the severe earthquakes felt in Japanese cities ; and one that passed across Yedo within the memory of living men caused great destruction of property and loss of life. I am confident that such calamities as these are due simply to the fact that the Japanese place tile roofs upon their houses, for these tiles can readily be shaken loose, and are heavy and dangerous.

The Japanese, as I have said in an early part of this book, suffer much from fire, and it is probable that the dread of falling sparks led to the use of tiles instead of thatch about five hundred years since. Yet thatched buildings are even now common in Japan. Thatch in Japan is formed of straw, certain fibrous materials, or layers of the inner bark of a kind of cone-bearing tree. It looks well, but in warm weather is highly combustible. Some of the prettiest roofs that I have seen in Japan are formed of what I might describe as little wooden tiles. Now there are



many substances known to chemists, as I have already said, which will render both vegetable fibres and wood almost wholly incombustible ; hence wooden roofs treated with such substances might be advantageously used, and thus the one objection which at present exists to a Japanese building, as a thing intended to resist the shock of an earthquake, would be removed. It would be interesting to know whether injury resulted to the inmates of any thatched buildings during recent earthquakes.

In an account of the destruction of Chios by earthquake given in the *Standard* of April 12th last, the correspondent says :—

“ Climbing over the hills which surrounded the town, one looks down upon a confused heap of ruins, where little more than a week ago stood one of the most prosperous cities of Asiatic Turkey. Out of three thousand houses which were standing there, not a hundred are now habitable.

“ I descended a long, narrow street leading to Marina, through the once most populous quarters of the city. In doing so I had to climb over successive heaps of *débris* from ten to fifteen feet high, lying between tottering walls rent into most fantastic shapes.

“ Some of the houses had been lifted bodily off their foundations. Others were crushed into shapeless heaps, with here and there a single wall or minaret left standing above the chaos.

“ Right and left of the direction I took were narrow streets, which are now so entirely blocked as to be undistinguishable. Here and there I caught sight of a row of houses with window panes, doors, and balconies comparatively uninjured, whilst behind this deceptive framework the roof and every story had been torn from the front walls.

\*                    \*                    \*                    \*                    \*

“ The bazaar, which is wooden, suffered little, and the markets are now gradually being reopened. They are comparatively well stocked, owing to provisions constantly pouring in from other parts of the island.”

Here we have an instance of the value of wooden buildings in a land subject to earthquakes ; and certainly there is but little danger of being injured from a shock if the building is of wood and the roof is of a material which is light and can be held securely in its place. Yet the Europeans in Tokio are encouraging the Japanese to build European houses with stones and bricks ; and the Government offices are of these materials, while it is proposed that the new Mikado's palace be also of European character.

To me nothing could be more absurd than this departure from architectural custom which has had the sanction of ages ; and the result of this incongruous innovation will probably be a return to the native style of building after the occurrence of some dire calamity.

It may be argued that Japanese castles are built of stone ; but it must be remembered that these are formed of vast blocks so arranged, one on the other, that each wall is of pyramidal shape, slanting from the base to the apex in the old Egyptian manner. These walls are also supported from within, and are tied together with timbers of great size ; indeed it would almost be fair to say that the castle towers are wooden buildings of immense strength faced with slanting walls which consist of stones,—each stone being in some cases more than twenty feet in length.

It would obviously be impossible to build ordinary houses of vast masses of stone, or to give to their walls that thickness and slope which would render them to any degree safe against shocks of earthquake. But the new buildings erected in Tokio have neither of these safeguards against injury ; hence it appears that in their erection a risk is run which seems most unwise.

A notable instance of the Japanese understanding of the conditions under which they exist occurs in the manner of giving security to pagodas. Pagodas are often of great height, yet many have existed for seven hundred years, and have withstood successfully the many vibrations of the ground, which must have inevitably achieved their overthrow had they been erections of stone or brick.

When I first ascended a pagoda I was struck with the amount of timber employed in its construction ; and I could not help feeling that the material here wasted was even absurdly excessive. But what offended my feelings most was the presence of an enormous log of wood, in the centre of the structure, which ascended from its base to its apex. At the top this mass of timber was nearly two feet in diameter, and lower down a log equally large was bolted to each of the four sides of this central mass.

I was so surprised with this waste of timber that I called the attention of my good friend Sakata to the matter ; and especially denounced the use of the centre block. To my astonishment he told me that the structure must be strong to support the vast central mass. In my ignorance I replied that the centre part was not supported by the sides, but upon reaching the top I found this monstrous central mass suspended, like the clapper of a bell ; and when I had descended I could, by lying on the ground, see that there was an inch of space intervening between it and the earth which formed the floor of the pagoda.

The pagoda is to a Buddhist temple what a spire is to a Christian church ; and by its clever construction it is enabled to retain its vertical position even during the continuance of earthquake shocks : for by the swinging of this vast pendulum the centre of gravity is kept within the base.

I now understood the reason for that lavish use of timber which I had so rashly pronounced to be useless ; and I see that there is a method in Japanese construction which is worthy of high appreciation. In the absence of any other instance the employment of this scientific method of keeping the pagoda upright shows how carefully the Japanese have thought out the requirements to be met.

In a work like the present, which treats of architecture somewhat incidentally and with the view of throwing light rather upon the decorative arts which have arisen out of it than of examining the structural methods employed, I cannot afford to enter minutely into Japanese construction. All I can do in the present work is to offer a few illustrations of the principles which govern their methods of construction and of certain effects produced.

The drawing which is given (Fig. 41) of the east gate of Nishi-hongwan-ji at Kioto may be taken as an example. Each end consists of three pillars or uprights—one circular and two square, tied together by horizontal members. Between these are carved panels. The central of the three horizontal members that tie the uprights together is flat, and protrudes considerably beyond the uprights. Above is a system of brackets which act as a cornice, and by which a heavy thatched roof is sustained.

A glance at our sketch (Fig. 41) will at once show the beautiful manner in which this work is framed together. The stones which form the bases of the columns, and on which the shafts loosely rest, are at once apparent. The gate as a whole will be noticed as a work constructed with due regard to strength as well as beauty.

In this gateway there is an amount of complication in the upper bracketwork which may render it somewhat indistinct to those not conversant with this method of building; but by reference to illustrations 72, 73, and 74, the principle which guided the architect will be better understood.

In speaking of structure reference ought to be made to the

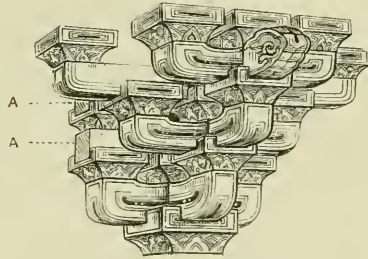

FIG. 72.—COMPOUND BRACKET.

A A, Sections of horizontal members carried by the brackets.

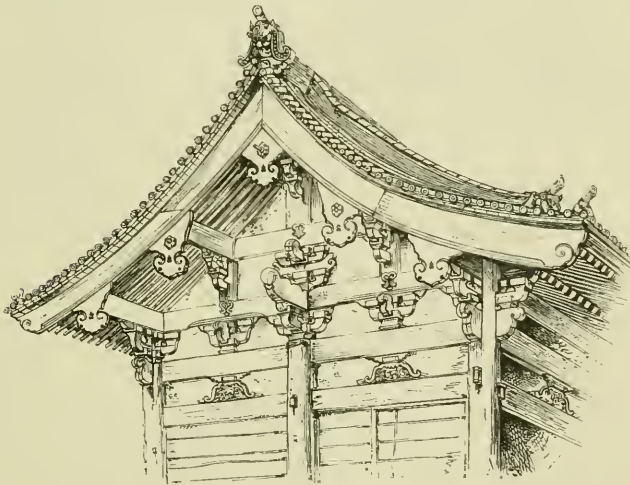

FIG. 73.—ENTRANCE-GATE OF THE TEMPLE OF DAI-BUTZU, KIOTO.

bridges of Japan. These, some have said, prove that the Japanese have no true understanding of the principles of construction. To me it seems that we might as well deny the existence of structural knowledge in England, because in certain parts of

the country we find planks spanning rivers, and other ill contrived arrangements for the crossing of brooks, as deny to the Japanese a knowledge which they possess to a remarkable degree, because we find in their bridges instances of false construction.

Japanese bridges are of many kinds:—some are most primitive in character, others are of a complex nature ; while some show an

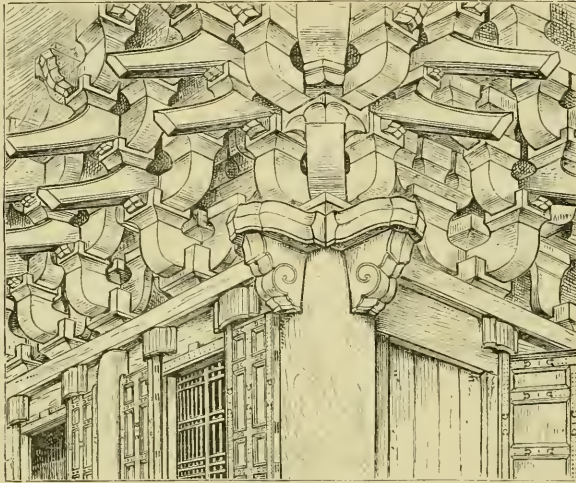

FIG. 74.—BRACKETING SUPPORTING ROOF OF TEMPLE-GATE, CHIONJIN, KIOTO.

understanding of true structural qualities. Figs. 75, 76, 77, 78, and 79 give native drawings of some common bridges of the country.

The most simple bridge—if bridge it may be called—used for the passage of rivers where there is but little traffic consists of two trunks of trees placed side by side, and having one extremity fixed at one side of the river, while the other, which reaches within jumping distance of the opposite side, is held in its position by a rope fastened to a peg at some little distance up the stream. (Fig. 80). But from this they advance through every conceivable degree of complexity.

There are bridges formed of piles of fagots (Fig. 75). There are bridges made of straight bamboos, resting on supports in the river so that the bridge is flat (Fig. 76). There are others similarly



FIG. 75.

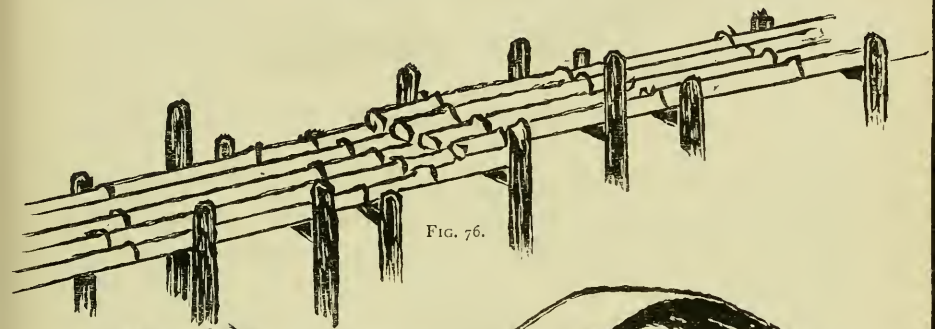

FIG. 76.



FIG. 77.

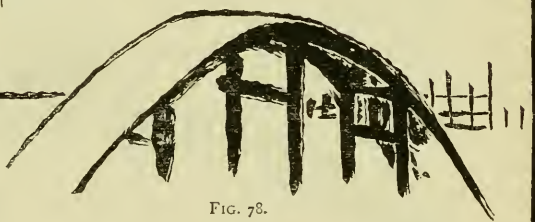

FIG. 78.

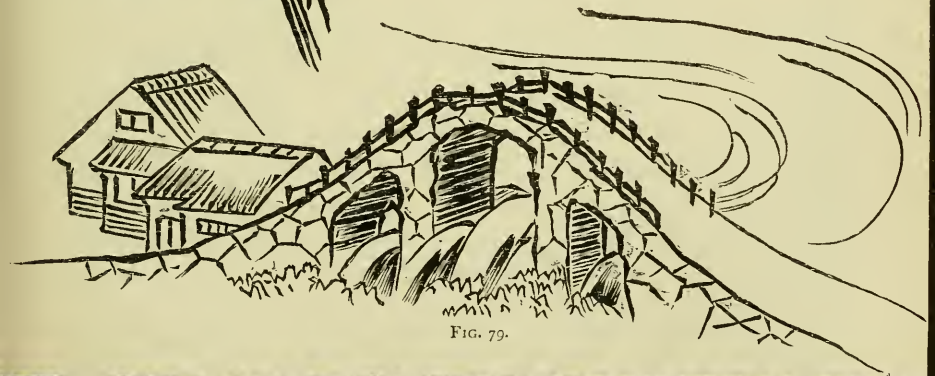

FIG. 79.

NATIVE BRIDGES, FROM BLOCKS DRAWN AND ENGRAVED IN JAPAN.

formed, only with the centre raised so that the bridge somewhat resembles an inverted V. There is also a bridge in Japan formed of stout planks, which rest on the decapitated branching tops of

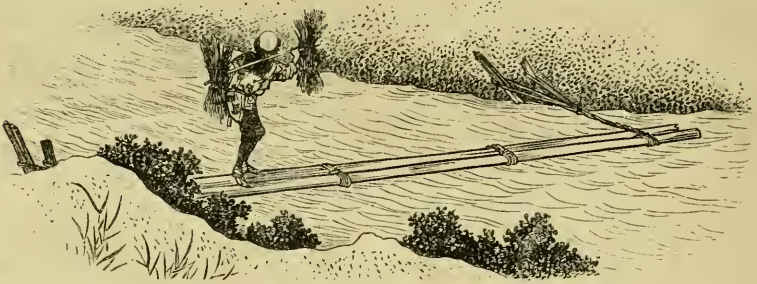

FIG. 80.—SIMPLE BRIDGE.

two large trees. There are bridges supported by a complicated system of bracketing; there are others consisting of semicircular arches; while in Kioto we find what is called the “spectacle

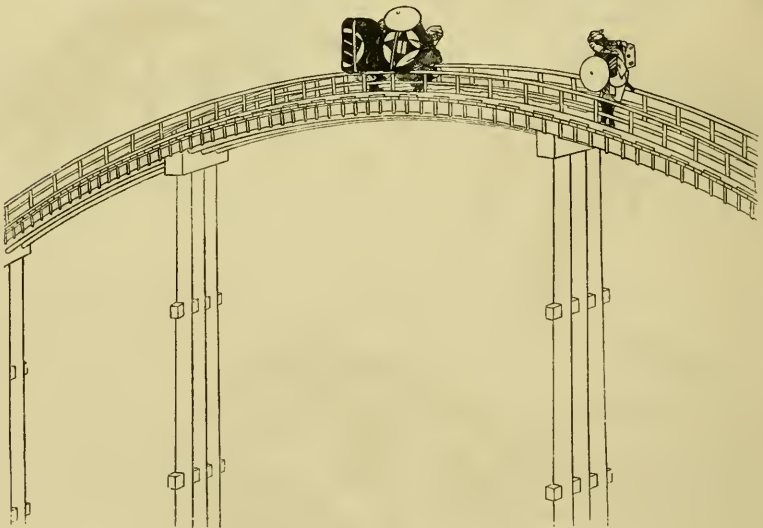

FIG. 81.—ARCHED BRIDGE.

bridge,”—a bridge with two circular openings through which the water flows. But what has caused Europeans to regard the

Japanese as devoid of a knowledge of structure is the fact that some of the bridges which have the arch form are yet propped by supports (Figs. 77, 78, 79, and 81). As these supports come in contact with the under surface of the arch, such bridges reveal no understanding of structural qualities. So far as I have seen, these curved, and yet supported, bridges are invariably formed of wood; hence they differ widely from arched structures formed of stone. Yet if Japan contains many illustrations of false structure, these do not prove that Japan does not possess men who have perfect understanding of true structural principles.

The Japanese have never been great engineers, but they have, undoubtedly, been great architects. Architecture involves a knowledge of structure, but engineering does not necessarily involve any knowledge of the beautiful, as we so often discover to our dismay in England. A man may be able to construct an edifice so that it will stand securely, but he may be altogether unable to erect a beautiful building. No one could look upon either the great temples of Shiba or of Nikkô without feeling that the architect of these glorious buildings understood perfectly the principles both of construction and of beauty.

One great peculiarity of Japanese construction is the system of bracketing which it so often employs—a system which it carries to a remarkable extent in some cases; and which it almost invariably uses for the support of the overhanging roofs of richly decorated temples.

An elaborate system of bracketing frequently intervenes between the roof and the uprights, and acts as a sort of cornice (see Figs. 41 and 70). In some cases this system is carried to an extent which seems altogether extravagant. (In Figs. 68 and 74 we have the most complicated arrangements of brackets that I saw while in Japan.) In many cases we have brackets embedded in the wall where plaster intervenes between the timbers, as in Figs. 46 and 73, and in internal work they are almost as common as on the exterior of buildings. As the reader may have some difficulty in understanding the nature of these brackets, we have given a separate view of one, in which two of the horizontal



members carried are shown in section, while others would rest on the uppermost supports (Fig. 72).

This bracketing is certainly the most distinctive and characteristic feature of the Japanese systems of construction ; and while in some cases it is both useful and ornamental, in others it is carried to an extent that is almost absurd. But while our Early English architecture is simple and constructively correct, we find in the Later Florid or Decorated work much that is excessive and worthy only of condemnation : Henry the Seventh's chapel at Westminster is, when considered in relation to its structural qualities, more false than any building that I saw during my travels in Japan.

Internally the construction of buildings varies much. In some cases we have ceilings, while in others a more or less open structure is employed. When the structure is open, something resembling our "King-post" is often used ; but instead of one upright we generally find two standing on the horizontal beam from which they rise, as in Fig. 47. In other cases this member is single, as in Fig. 73, while in some instances it is dispensed with altogether.

When we find a ceiling it is almost invariably arranged, as in the temples of Shiba, Uyeno (Figs. 17 and 18), and Nikkô, into squares of from eighteen to twenty inches in diameter, and has a somewhat *coffered* character. In this case each coffer may be decorated ; or may be divided into a series of small coffers, each of which is not more than one inch square (Fig. 18). In both of these cases we find the crossings of the framed structure tied by perforated or hammered metal casings (Figs. 17 and 18). In those instances in which each coffer is divided into a series of small squares the ceiling is connected with the walls by a large coving, traversed vertically by raised bars similar to those which divide the coffers into squares (Fig. 18).

The Japanese affirm that all such ceilings as those of which we have just spoken, and all such covings as that just mentioned are of Corean origin ; and that they are not native inventions. Thus we have another instance of the strange

influence which Corea appears to have exercised upon the arts of Japan.

To me it seemed strange that these simple and beautiful ceilings should owe their origin to any portion of Continental Asia ;

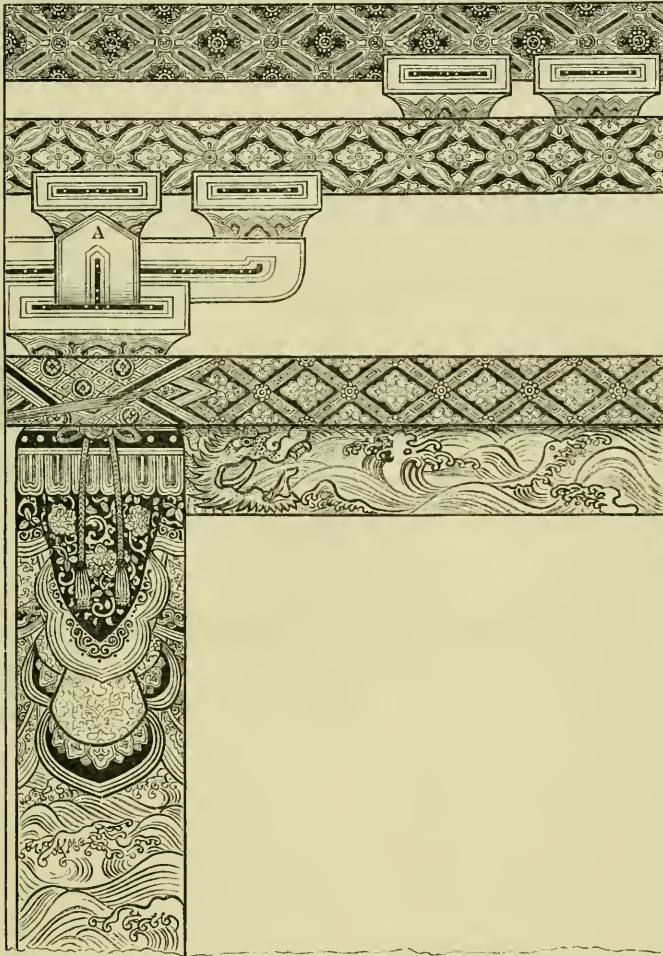

FIG. 82.—COLUMN AND TIE-BEAMS FROM THE CHION-IN, KIOTO.

for I saw nothing in any way resembling them in the temples of China or any other part of Asia that I have visited. Yet one is almost led to believe that the Japanese are right in referring many of both their arts and those of the Chinese to the

Coreans, and that this nation has at some time had arts and manufactures of a most artistic character. But it cannot be doubted that many of the arts of Japan, as well as the ornaments employed by the Japanese, owe their origin to Central Asia, for such temples as that of Hōwō-do in Uji could only have been decorated by one having experience of Indian art.

Fig. 82 gives a portion of internal structure, where a decorated circular column bears a horizontal beam placed flat-wise, and to which strength is given by a vertically placed timber. Over the top of

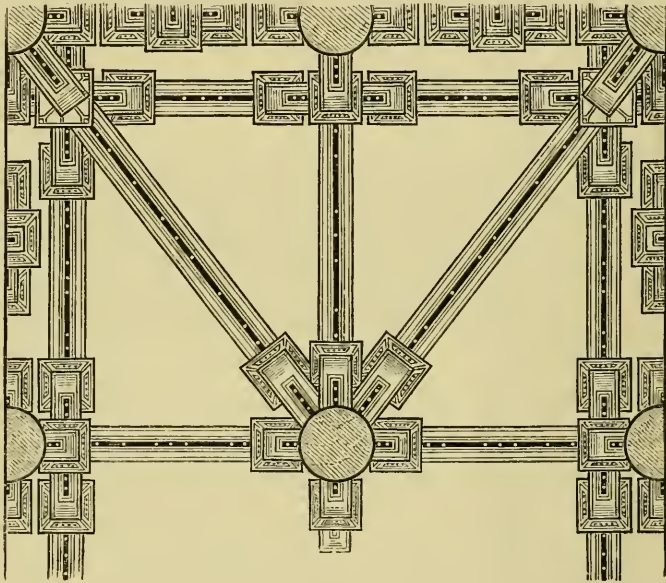

FIG. 83.—PLAN OF PART OF THE OPEN ROOF IN THE GATEHOUSE OF THE TEMPLE TOFUKU-ZI.

the column rises a system of brackets supporting horizontal members; but a timber which would rest on the advancing bracket A, Fig. 82, has been removed, as it would hide that shown in our illustration, and by which the uppermost horizontal member is supported.

Fig. 83 gives us a plan (as seen from below) of a portion of open-roof structure where the brackets spreading from the tops of the columns may be observed, as well as the timbers which rest upon them.

When we consider Japanese buildings as structures adapted to

withstand the earthquake, the character of the windows, which are light wooden frames covered only with paper, should not be overlooked (Figs. 37 and 84). It will be apparent to all that the use of glass would be accompanied by great danger in a land subject to earthquake shocks: and while paper has the disadvantage of not being transparent, the Japanese suffer but little from its slight opacity, as during the day some of the window-slides are always removed from their places; and to an abundant admission of fresh air the Japanese make no objection. Indian windows (Fig. 85) are only Japanese windows cut in stone, and they clearly show that they are copies of structures which were originally formed of wood.

Enough has, perhaps, been already said to show that the Japanese have a knowledge which enables them to produce buildings of a most enduring character,—calculated to resist the shocks of earthquake, and to fulfil the conditions demanded by considerations of climate and the materials at command.

Although not strictly belonging to the subject, there is a feature which we ought to notice, as it is of considerable importance when viewed in relation to the material of Japanese buildings. I mean the metal sockets in which the ends of all timbers of elaborate Japanese buildings are incased. The sockets are used to exclude water from contact with the cross-grained portions of the wood.

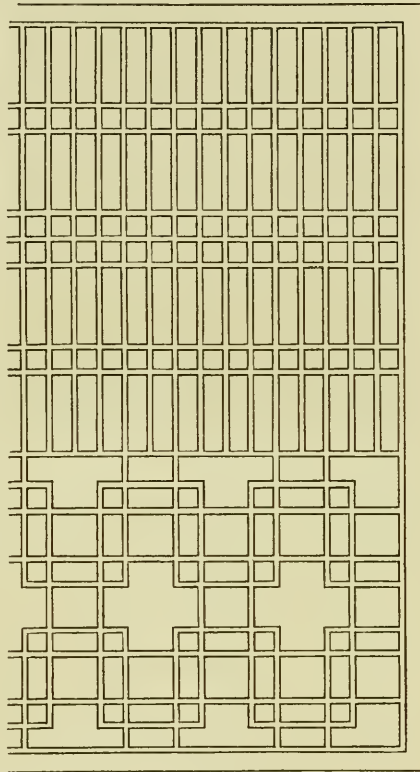

FIG. 84.—PART OF A WINDOW.  
The window is formed of laths over which paper is  
“strained,”—the paper being on the outside.

In Fig. 44 it will be noticed, as I have already pointed out, that the bases of the columns are of stone, and that upon these stone

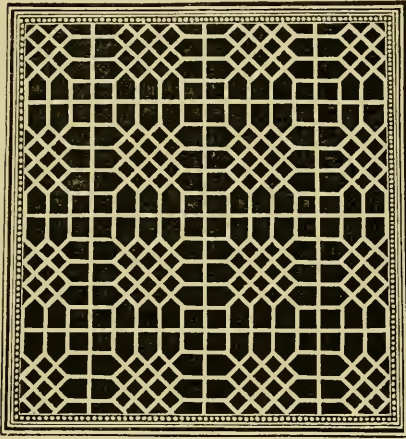

FIG. 85.—INDIAN LATTICE WINDOW FORMED OF  
PIERCED STONE.

bases rest loosely the vertical columns which form the main supports of the gateway. It will also be seen that the portions of the columns resting on these bases are incased in bronze sockets, on which ornaments are raised by hammering. The ends of the horizontal members are also incased in a similar manner, as will be seen in the same illustration. Fig. 43 gives the same horizontal members as the cut last referred to, as

well as the whole of the pierced and carved panel which we see but in part in Fig. 44.

In some few instances metal-work is added for the sake of mere effect, and not with the view of serving any useful purpose. On the corners of the frame in which the carving occurs (Fig. 43) we have metal bindings which are useful; whereas in the centre of each side an ornamental metallic plac occurs which only serves a decorative purpose. As a rule, however, the metal bindings are used with the view of protecting the cross-grain ends of wood from decay through contact with water.

Another method employed throughout the whole of Japan with the view of saving wood from decay is that of using little roofs in order to protect the end grain from moisture. I have seen individual posts roofed, as well as palings around enclosed land. Indeed, everything is roofed in Japan; and in some cases the complicated roofing of boardings, railings, posts, lamps, etc., is as curious as it is interesting.

A word may now be said on the methods of building. Peculiarities occur most frequently in their walls; for these, unlike their

houses, are often formed in part of hewn or rag-stone, while the upper portion consists of a kind of lath and plaster-work, of tiles placed horizontally with mortar between, or of various other materials; but in all cases the wall is carefully roofed, and thus protected from the weather. Figs. 35, 45, and 86 give typical wall formations. One has a boulder-stone base and stone corners, whereas the other two have bases formed of hewn stone,—the one of rectangular blocks, the other of “rag.” These latter have wooden corners (and this is the most characteristic arrangement), and have five horizontal lines running throughout their entire length. Whenever these lines occur the wall is of dull yellow colour (yellow-ochre) and the lines are white. This arrangement of lines indicates, as I have before said, that the high priest of the temple is a near relation of the Mikado.

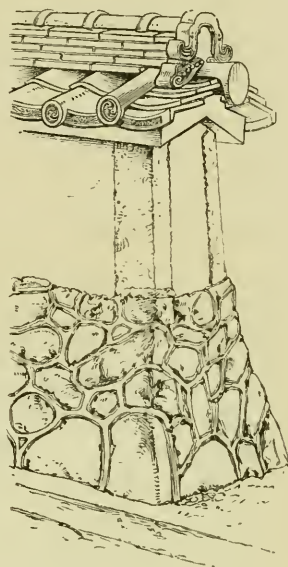

FIG. 86.—END OF WALL AT KIKŪ  
UJI, NEAR KIOTO.

It will be noticed that these walls are more or less conical in shape, being broader at the base than at the upper portion; but we have already pointed out that wherever stone is used in the construction of a building, or any material other than wood, this system of building is employed; and that by it alone the disastrous effects of earthquake shocks can be averted. The canopy covering the water-tank at Shiba is supported on monolith granite columns, but these slant inwards at the top (see Fig. 16).

In the case of large temples and elaborate shrines, as those of Nikkō and Shiba, we often find wall within wall, each enclosing a court. The innermost of these walls surrounds the central and most important of the temple buildings. These inner walls are generally differently constructed from those which form the outermost enclosure of the temple buildings, and are in some cases very beautiful.

Here we generally find a solid stone base, from which rise vertical wooden members held together by horizontal ties. These latter are so disposed, that above and below we get a long narrow panel, while in the centre we have a space of much larger size. In such a wall as this the horizontal tie-pieces are frequently decorated and the panels filled in with carved-work, the whole being coloured and roofed over (Fig. 69). A panel similar to those of which I here speak is figured on page 182 (Fig. 62); but this particular carving is from the castle of Nagoya, where it is situated between two rooms, from both of which it can be seen. It is carved on both sides, though on each surface the pattern is somewhat different.

In some cases the bases of walls are "pointed;" but whenever this occurs we have no mere facing of the line of mortar which exists between the stones with a harder and more durable material, but the formation in mortar of some kind of semicircular, or semi-elliptic ridge three inches in diameter, and protruding to a considerable distance from the surface of the stone. This curious method of "pointing" gives a strange aspect to many Japanese walls; but the effect produced is, to my eye, more strange than beautiful.

We now come to the consideration of Japanese architecture, or beautiful building; for architecture is not mere building, but the art of raising edifices which are beautiful as well as useful. But before going into its æsthetic qualities we should glance at its origin and history; yet the data necessary for tracing the development of Japanese architecture are so imperfect that little can be said concerning it.

Although the temples of Isé have been rebuilt at the end of every third term of seven years, every plank and every post now to be found in their construction is of precisely the same shape, and of the same size, as those of the original structure which was erected nineteen centuries since. We have here, then, evidence that the present method of building was known to the Japanese at the time of Rome's ancient greatness; and while speaking of this temple I may say that the circular pieces of wood, which rest in a horizontal series on the cresting of each roof, can be demonstrated

to owe their origin to circular bundles of thatch, which were strapped over longitudinally placed reeds to form with them the cresting of the roof (Fig. 53).

The next building, as to date, with which I am acquainted is that used for the reception of the Mikado's treasures at Nara. It was built more than a thousand years since; and while this, like the buildings of Isé, stands upon legs resting loosely on stones, its sides are formed of horizontally-placed triangular blocks of wood, with their points outwards, arranged like the timbers of the log buildings in Russia (Fig. 30).

I am unable to trace the history of Japanese building during the next three centuries; for, until the erection of the great Buddhist shrines from seven to five hundred years since, no advance in architecture seems to have taken place in the country. But the development of Buddhism, and the patronage which it received from the Shogun, gave a marvellous impetus to architecture, and it now entered upon a florid and highly decorated period.

Chinese buildings appear to owe their origin to a tent or a junk. The tent obviously consisted of a horizontal pole, over which a fabric was thrown, supported at its ends by crossed sticks. The temples of Isé show the crossed supports in a marked manner; but there is here none of that swaying down of the roof which would indicate the tent origin, and which especially characterises Chinese edifices; yet in many Japanese buildings the horizontal pole is most marked, while the crossed supports have entirely disappeared.

In the water-tank of Shiba (Fig. 16) we have an illustration of this state of things; and here we have that curious bending-over of the roof as we approach the gable end which would represent the fall of drapery,—a peculiarity equally noticeable on that gatehouse of Nikkô which we figure on page 209.

In some cases the architecture of a nation has been derived from primitive buildings which are not of the tent character. This is the case with those edifices which the Egyptians raised from two to three thousand years back at Dendera, Edfou, Thebes,



and other places, where we find the columns consisting of bundles of papirii, lotii, and other plants bound together with cords or withes, and in some cases partially enveloped in a cloth wrapper on which hieroglyphs are painted.

Although these columns are formed of stone, their origin is as apparent as if we had the original bundles of plants before us ; thus the bundles of reeds or of flowers which were used to form the walls of the primitive Egyptian dwelling became the prototype of those massive columns which exist to this day on the banks of the Nile.

While the origin of Egyptian architecture is thus apparent, it must not be supposed that the stone columns of Egyptian temples were mere copies in permanent material of the objects which formed their prototype ; for they are works in which the parts have all been subordinated to their positions as architectural members, and in which the plants have been so idealised as to become consistent ornaments of a structural part of a building.

A consideration of Japanese architecture makes it clear that certain structural members were, in some edifices at least, adorned either on feast days or generally with drapery, decorated papers, and the skins of animals ; for the capitals of their columns are in many cases decorated with imitations of these draped around them. In one case, as that in the temple of Chion-in at Kioto, a knotted cord, terminating in pendent tassels, appears to show that this drapery was originally tied around the column (see Fig. 82).

Immediately above this column, and enveloping the beam which rests upon it, is paper folded in an angular manner,—a method of folding common to this day in Japan ; while on the tie-piece on which the paper-bound beam rests we have the head of a monster, either represented as swimming in the water, or as the source from which water flows. In another column from the same temple (Fig. 87) the head of a monster forms the upper portion of its decoration ; and in both instances the columns themselves are entirely decorated with water, the crested waves of which are breaking in a curious and conventional manner.

It is difficult to understand why the columns and horizontal members of a building should be decorated with waves; for a column of water seems an absurd idea, unless we connect it with the water-spout, which may be common in a district visited by typhoons. If this be its origin, such columns may have some mythical association, in the minds of the Japanese, with a strange natural phenomenon which they dread. While I have no reason for saying that such is the case, it must be remembered that all Buddhistic art tends to remind the worshipper of the power of the Buddhist's god over all created things; and that it images forth such works as man should love, adore, or dread. Fig. 88 gives us the base of a column decorated with water ornamentally treated.

Strange as it is that a column should be decorated with water, we yet find the "wave-scroll" used by the Egyptians, and then by the Greeks, on various parts of their buildings. Certain zigzag arrangements of lines, which symbolised water, were also used on the walls and on the ceilings of Egyptian temples and tombs; thus the use of water in strange and unexpected positions is not peculiar to the Japanese. With the

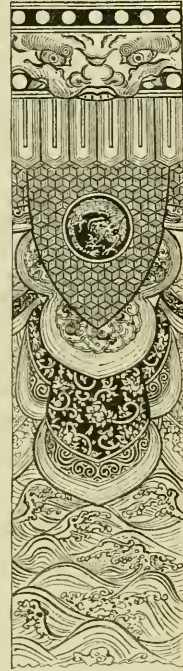

FIG. 87.—COLUMN FROM  
THE CHION-IN, KI-  
OTO.

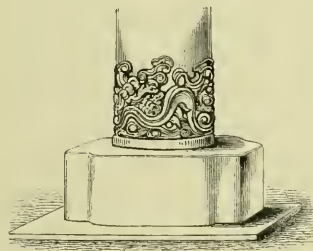

FIG. 88.

Japanese the rendering is less conventional, however, than with the Egyptians and Grecians.

The edifice which covers the water-tank of the temple of Shiba (Fig. 16) has monolith columns, the upper parts of which are decorated with coloured conventional drapery, in the manner of those of Chion-in at Kioto. Yet the temples of Shiba and Chion-in differ widely from each other, and are separated geographically

by a distance of more than three hundred miles. In the days when they were erected, it must have been very difficult to get from place to place ; yet we find this decoration of the columns by imitation drapery in both buildings. And, strange to say, in neither case do we find columns thus treated in the main building ; for at Shiba the decoration is seen on the columns of the water-tank, and at Chion-in on the pillars in the gatehouse. At Kioto, as we have seen, the shafts of the column are decorated with water : in Tokio the shafts are bare stone.

Here, as in the case of the Egyptian columns, we have no vulgar imitation of drapery ; but idealised work, in which detail is subordinated to architectural fitness, and in which structural qualities are not interfered with by any mere imitative renderings of folded tissues. On the score of conventionality there is therefore nothing incongruous in this peculiar decoration.

While there is little in Japanese buildings, whether ancient or modern, to convince us that they were in any way derived directly from the tent, there is much which tends to show that the Japanese temples were suggested by Chinese buildings. Yet these Japanese temples are, as art works, inexpressibly superior to the Chinese models from which they were derived.

We have seen that Chinese buildings owe their origin to a particular form of tent or to the junk. Were we to inquire into the nature of Arabian architecture, we should find that the rooms of an Arabian house are little more than representations in stone, plaster, and colour, of square and flat-topped tents formed of gorgeous tissues. While yet nomads, the Arabs used to produce in their looms rich fabrics, such as they used in the construction of their primitive dwellings. The temples of ancient Egypt had their prototype in the reed dwellings which were the primitive houses of the country ; hence, we should look for the origin of Japanese architecture in the early abodes of the Japanese people.

If, with the view of discovering the nature of the original dwellings of Japan, we consider the structures still raised by the Aino inhabitants of the northern island (called Yesso), we see that the Aino temples are of the rudest character. A few slender up-

rights, on which rest horizontal timbers of but small dimensions, give support to a simple thatched roof. There are no sides to the building. The timbers are unplaned. In short, nothing which would distinguish it from the works of uncivilised man can be seen in any part of an Aino structure (Fig. 89).

Such is an Aino temple of the present day ; and there is every reason to believe that the Ainos were the original inhabitants of Japan. The temples which these half-civilised yet kindly people now raise are surely mere copies of those which for many centuries they have been in the habit of erecting.

But the simple Aino temple has all the leading characteristics of a Japanese building of the present day. It consists of uprights, on which rests a somewhat massive roof.

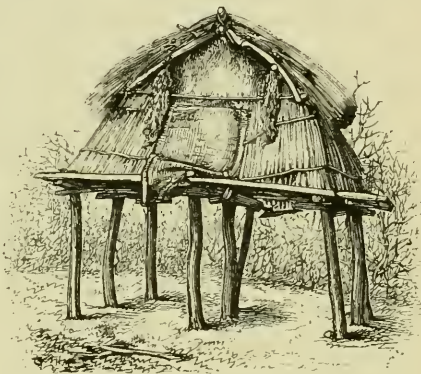

FIG. 89. — AN AINO TEMPLE.

We have already noticed that the sides of a Japanese house are generally removable, and that the building consists of uprights, a floor, and a roof. Primitive man has always used the ground as his floor ; and that strange nomadic race, the gipsies, which has so long been found among the various civilised peoples of Europe, makes no floor for its primitive dwelling. In like manner, the Aino buildings are floorless ; but the mere needs of an advancing civilisation would lead to the construction of this necessary adjunct to any building designed to give protection from damp as well as rain.

We have, then, the prototype of the whole Japanese system of building, in the rude temples of the Ainos. But as time has gone on, advances have been made, and influences have been brought to bear upon the primitive methods of building. Just as the Roman invasion and the Norman conquest influenced building in Britain, so the Chinese, the Coreans, and certain Buddhist

missionaries from Central Asia carried to Japan new styles of architecture which gave rise to that florid though beautiful architecture which we find in the great shrines of Nikkô. There is this difference, however, between the two cases. In Britain the Romans and the Normans came and built noble edifices which influenced later works ; whereas in Japan the influence could in most cases only have been derived from drawings received from the Asiatic continent and from the teachings of missionaries.

A feature which must not be overlooked in the consideration of Japanese architecture is the nature and "pitch" of the roof and the manner in which gables are dealt with.

All architects know the value of the gable in producing picturesque effects. It was found in most houses during the mediæval period, both in England and in most countries of Europe ; but I doubt whether any nation has used it with more skill, or with better effect, than the Japanese. Indeed, I have some sketches of Japan which are peculiarly picturesque through their wealth of gables (Fig. 48).

The pitch of the roof in Japan, though not high, suffices to give perfect protection from the weather. While the high roofs which we still see in Nuremberg, Troyes, many of the Rhenish towns, and on some of our own old buildings, are eminently picturesque, I doubt whether they are as beautiful as those of lower pitch ; and certainly they occupy much space in which only poor rooms can be arranged.

The gable of Nishi-hongwan-ji (Fig. 90) will give a fair idea of the pitch of a Japanese roof ; but some buildings have gables somewhat higher, in relation to their width, than that which is here shown. Figs. 91 and 92 give another gable and detail of roof which will be of interest to the student.

Japanese gables are generally broken by ornaments, as reference to those of Nishi-hongwan-ji (Fig. 90) will show. That of the entrance gate of the great temple of Dai-butzu at Kioto, of the gate Kanaman of the shrine at Nikkô (Fig. 68), of the water-tank at Shiba (Fig. 16), and that of the street lamp (Fig. 58), will show the scroll ornaments which occur under most

of these gables, especially those which fit in the upper angle, and the similar ornaments lower down (see Figs. 90 and 93);

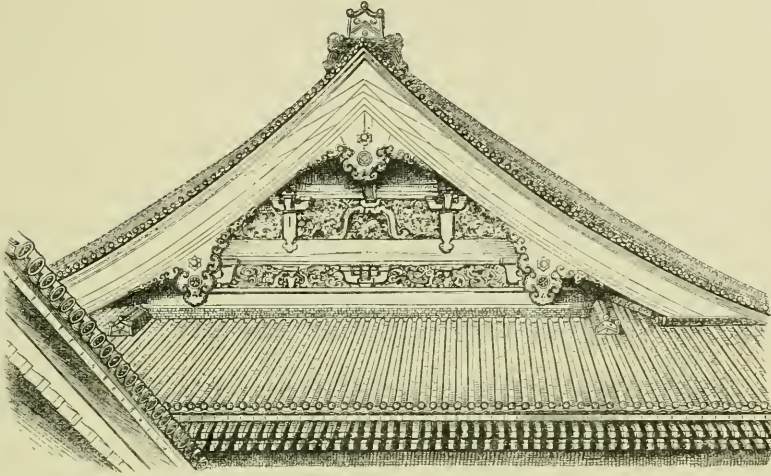

FIG. 90.—GABLE END OF NISHI-HONGWAN-JI.

these ornaments are purely of Chinese origin. Before passing from a consideration of architecture to ornament, we should notice

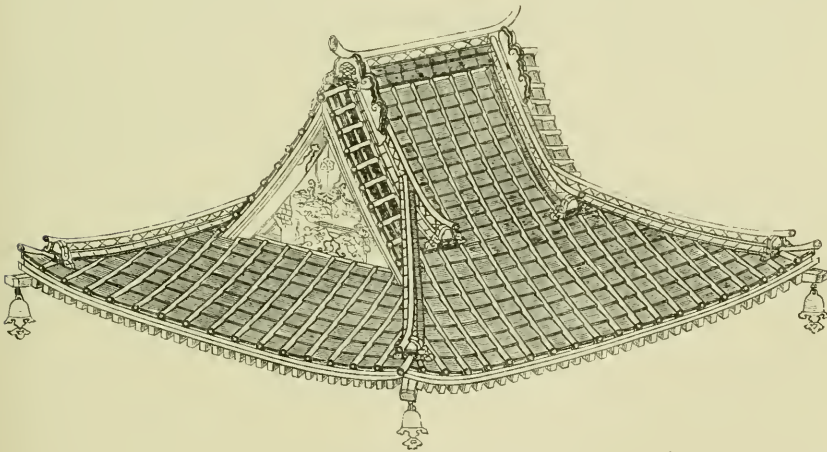

FIG. 91.—ROOF.

the forms of the tombs found in the cemeteries, for these have a character which renders them worthy of special notice.

Fig. 38 gives the tombstone most commonly met with ; while Fig. 40 represents the monument erected to commemorate the Corean conquest. Each is similar, both in form and in character.

In order to understand the nature of this structure we must

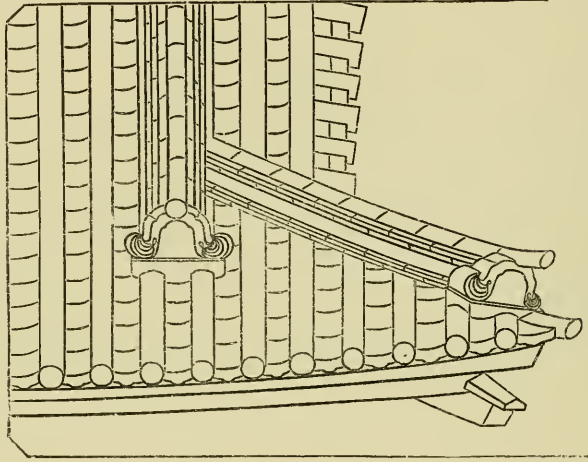

FIG. 92.—PORTION OF ROOF.

refer to India, China, and Tibet, where we commonly find objects similar to this in connection with ecclesiastical edifices.

The form used on the continent of Asia we give in Fig. 40, where the lower square stone represents the earth, the circular

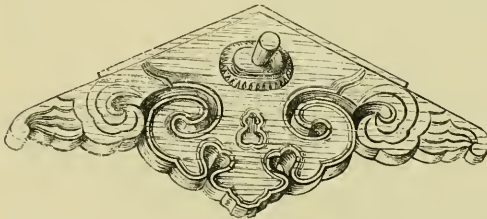

FIG. 93.—ORNAMENT FROM GABLE END OF BIŪ-DO-IN AT UJI  
—a temple recently destroyed. It was carved in the year  
1046 A. D.

stone water, the triangle fire, the crescent air or wind, and the spear-head ether or heaven. Inman tells us that in Egyptian mythology the pyramid, a Phallic sign, plays an important part. It belongs to Siva = the sun

= fire = life. By one complex symbol, very common on ancient Hindoo monuments, the universe was thus represented. Notice the upward gradation : first we have the earth, then water ; and these two constitute this globe. Then comes the creator = God,

whose emblem—flame—mounts upwards. He is the author and representative of all life upon the globe, and he is connected by the crescent moon with heaven. The spear-head is an emblem of the divine source of life and of the doctrine that perfect wisdom is to be found only in the combination of the male and female principles in nature.

The manner in which the Japanese monument has become modified is apparent from our illustrations; but its origin is obvious. It is given here simply to illustrate the fact that certain forms of an architectural character have a significance not to be overlooked. The crescent moon is introduced as a symbol; but the symbol has reached Japan from the continent of Asia. Yet it is well to remember, when speaking of this monument, that originally, the Japanese flag was inscribed with both the sun and the crescent moon, and that this symbol was thus used by the Japanese at an early time. The more general form of a Shô-gun's tomb is given in Fig. 94, the form being altogether different from that of any other tomb that I saw in Japan.

With the view of enabling our readers to see how the plasterers, carpenters, and other workmen engaged on the erection of a building perform their work, we give illustrations (Figs. 95 to 100). Fig. 101 gives the tools which the carpenter employs in his craft.

We have now to deal with the decorations of Japanese temples; and the principles which govern the application of ornament to buildings. At the outset of these considerations we must recognise the fact that ornament should always be used for the enrichment of members structurally necessary; and that it should be so subordinated to its position, that each part shall have the necessary degree of prominence and that all the members shall combine to form a harmonious whole.

Enrichment of an architectural edifice may be carried to any extent; provided that the constructive members are always duly emphasised, and the whole of the parts combine to produce a grand and complete concord; but if ornament renders any part unduly conspicuous it is illegitimate and can only be condemned.



While some of the great temples of Japan are elaborately decorated, I do not remember one instance in which structure is falsified by enrichment; and in all cases the leading structural members are rendered prominent by colour or treatment.

If we take either the gateway (Fig. 41) on page 143 or that figured on page 207 we shall see that the structural members have

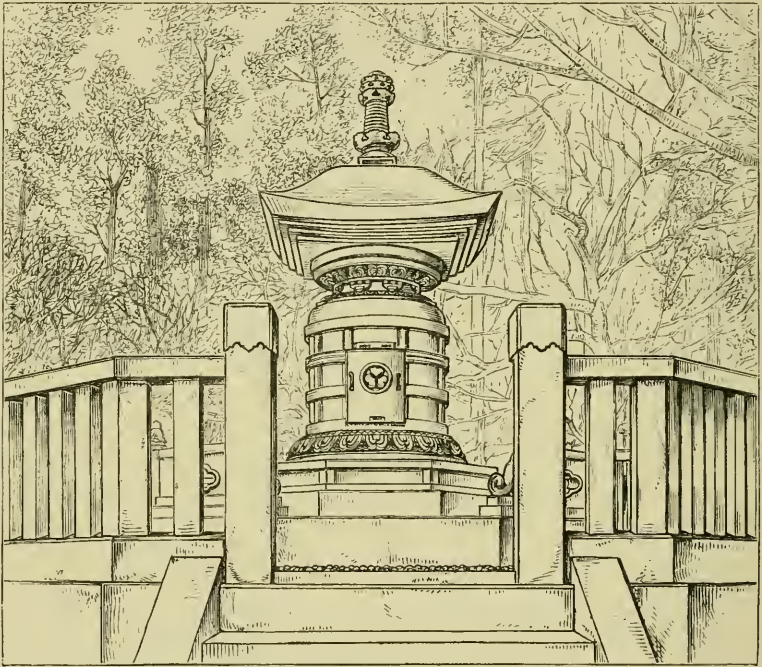

FIG. 94.—A SHŌGUN'S TOMB.

due importance, while the parts are richly ornamented; and that the members structurally necessary are those which ornament has enriched. But it must not be forgotten that these works are as elaborately coloured as the Alhambra at Grenada; and that gold, white, red, blue, and many other colours, in all their intensity, emphasise their different parts. How can I, without the aid of colour, convey to the reader any adequate idea of the nature of such works, and of the manner in which all the parts are subordinated to their true positions? As well might I try to explain

to one who was born deaf the richness of musical harmonies, as the nature and beauty of Nikkô without the aid of colour.

It should be noticed that much of the ornament on the leading and more exposed members of a Japanese building is flat or painted work, while that which is more protected is carved as well as coloured. Sometimes, however, the carved work remains uncoloured, while in other cases, as on certain columns at Nikkô, we have dark wood *basso-relievo* ornaments protruding from wood of lighter colour. It not unfrequently happens that this work, which is carved and uncoloured, is associated with coloured members. In some parts of the Nikkô buildings we have most welcome effects produced in this manner.

Of the nature of those carvings which form the panels in the various walls, gateways, and buildings, both at Nikkô and Shiba, I have spoken, when writing of my visit to these shrines. For the most part, they consist of groups of plants, birds, water, clouds, animals, and, in a few cases, of figures. All are wrought with consummate skill, and are generally actually pierced, the entire substance of the wood out of which they are formed being cut through.

The manner of the cutting is both bold and crisp. In all cases it manifests a perfect understanding of grouping, of the laws of composition, and of the distribution of parts; while nearly every panel has some poetic significance.

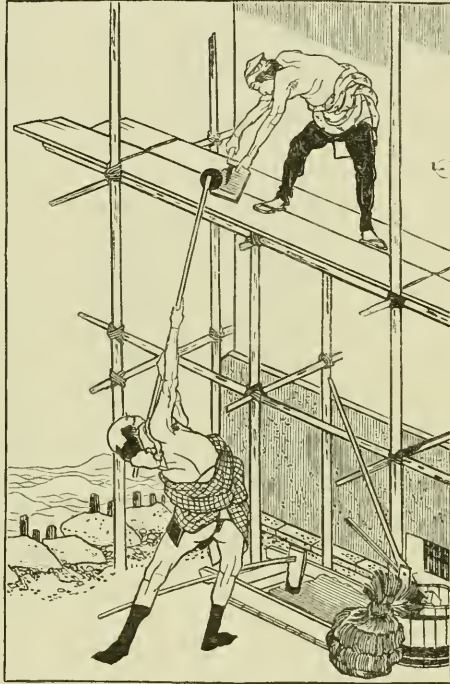

FIG. 95.—PLASTERERS AT WORK. After a native drawing.

One of the special features of Japanese decoration is seen in the use of diaper patterns on horizontal members and "string courses." We never enrich beams and joists by small, repeating,

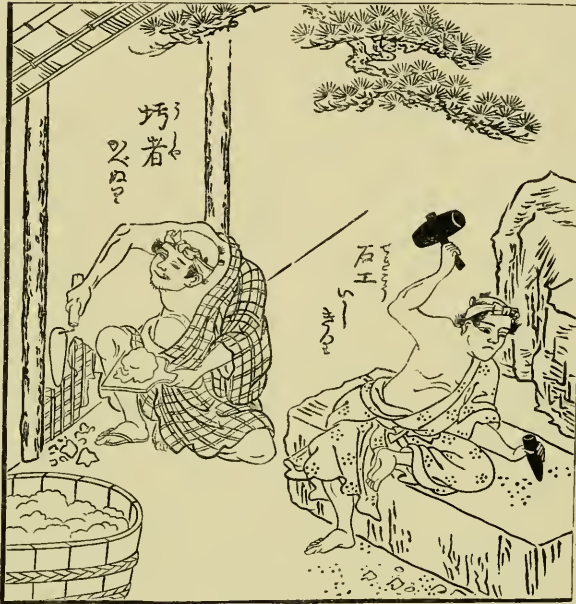

FIG. 96.—PLASTERER AND STONE-MASON AT WORK. After a native drawing.

geometrical patterns, but the Japanese do. Yet in no case have I seen a diaper pattern so placed on a beam that it was broken by the angle, or so that one, two, or more repeats of the pattern did not exactly fit on each side of the timber figured.

The diaper patterns thus employed are both varied in design and beautiful in character; and, considering their colour as well as their form, I should have been strangely puzzled to say what country had produced them prior to my visit to Japan. Had I guessed their origin I should have said—they must be our own Middle Age work.

I remember on one occasion the late Mr. Owen Jones asserting before a number of gentlemen that the Japanese had no ornament, strictly so called, and that their decorations consisted wholly of conventional representations of natural forms; while the

Chinese had ornament which was both national and good—a statement to which I then took exception. What would he have said could he have seen the numerous specimens of pure and



FIG. 97.—CARPENTERS AT WORK. After a native drawing.

characteristic ornament which I could now show? Few countries have more characteristic or more carefully considered ornament than Japan; and it is strange that while this is the case so little should be known respecting it in Europe even to this hour. It is a system of ornament carefully considered, with parts well distributed, points duly emphasised, full of careful thought. It includes diaper patterns, powderings, scroll-work, and symmetrical compositions (Figs. 102 and 103). It may be behind the Greek in purity of form and refinement of line, yet it has many of the best qualities of classic art. In power it equals the best of our own mediæval work; while in tenderness of expression, beauty of composition, and careful thought, it is even superior. The colour is equal to that of the finest illuminated manuscripts of the Middle Ages.

In treating of Japanese architecture, I should have liked to consider the very important question of PROPORTION. Everything in

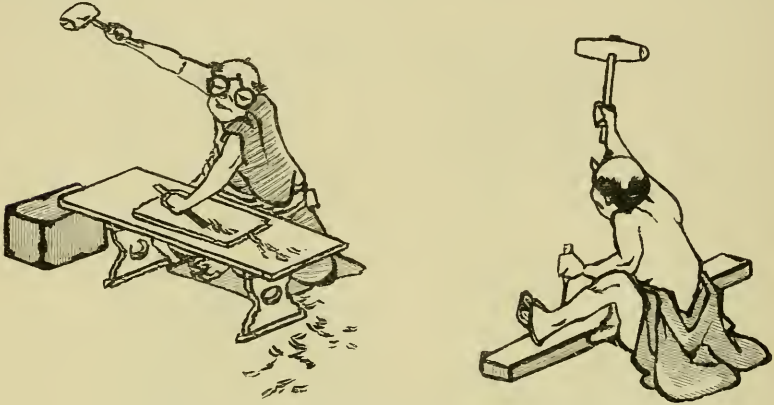

FIGS. 98, 99.—CARPENTERS AT WORK. After native drawings.

relation to Japanese building is determined by rule; but the explanation of these rules would require more space than can be



FIG. 100.—CARPENTER, WHO IS FATIGUED WITH HIS WORK, RESTING ON THE TOP OF HIS SHED. After a native drawing.

afforded in a work like the present: To give some idea of the plan on which the Japanese work, I may mention that all mats, such as are used for floor coverings, are in size six feet by three; and I have before mentioned that although the floors of their rooms appear to be covered by matting, the Japanese use only thick padded mats of this size as their floor coverings.

This being the case, it is obvious that all their rooms are, both in length and width, some multiple of a yard; but as all rooms appear to be of

one height, the relation between the area and the height is variable.

In the building of important Japanese houses there is an

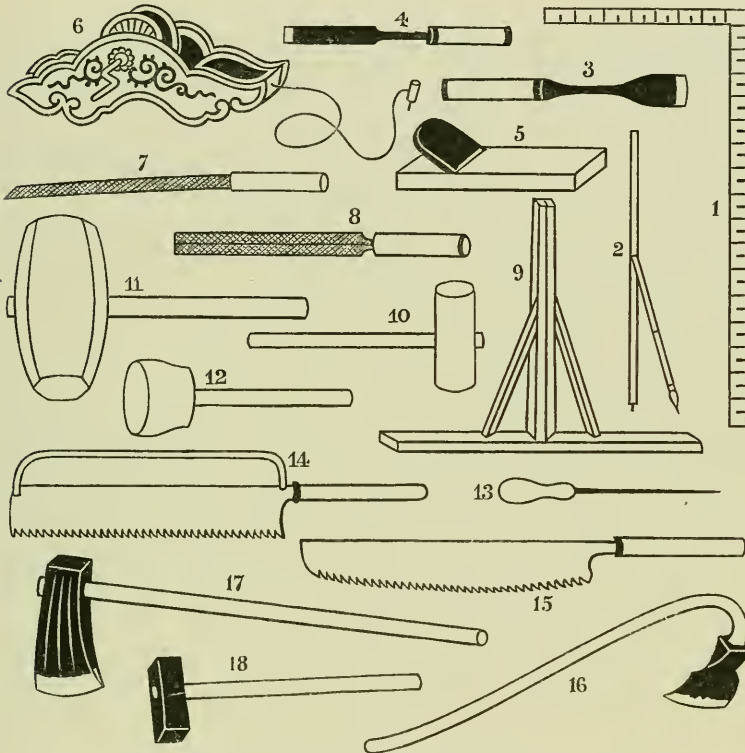

FIG. 101.—CARPENTERS' TOOLS. 1, Square and Measure; 2, Compass formed of bamboo stems, with a brush in one arm; 3, 4, Chisels; 5, Plane; 6, Line, which runs out over blackened cotton-wool; 7, 8, Files; 9, T-Square and Plummet; 10, 11, 12, Mallets; 13, Awl; 14, 15, Saws; 16, 17, Forms of Axe; 18, Hammer. After a native drawing.

etiquette regulating its construction; and the teacher of manners determines the plan of the mansion.

As I have named the teacher of etiquette, I may say that under the old feudal system he was an officer of some importance; for after a youth had left college he was apprenticed to this professor for general instruction in manners, and especially in the etiquette of the ceremony of tea-drinking—the Cha-no-yu (see page 157). The etiquette of Japan is most elaborate, and the volume setting forth the rules to be followed by a man of position

contains more than a thousand pages. There is an etiquette respecting the building of the house, respecting the reception of both friends and strangers, and respecting everything pertaining to one's

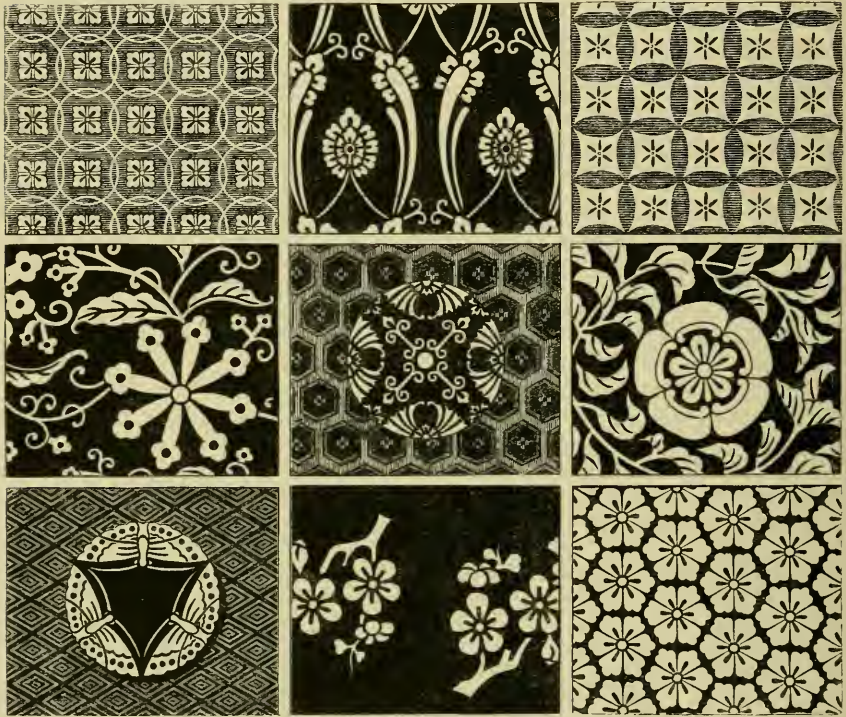

FIG. 102.—DIAPER PATTERNS AND POWDERINGS.

conduct under all circumstances. Even to the committing of harakiri rules are laid down, and the principles of etiquette determine, to a great extent, the character of a Japanese house. Figs. 104 and 105 give the manner in which an ornament and a torii are "set out," showing that all architectural objects are constructed according to rule.

I failed to discover that the columns of Japanese temples are governed by rule in the relation of diameter to height; yet I always found their proportions pleasant; I also found the proportion which one part of a temple bore to another almost invariably agreeable. It has been said that the proportion of one to two is

not so beautiful as that of one to three, and that this again is not so pleasant as three to five. Indeed, the law of proportion is this : the more difficult it is to detect the relation of part to part the more beautiful the proportion is.



FIG. 103.—PATTERNS OF JAPANESE FABRICS.

In Japanese temples I always observed this subtle relation of part to part, and the consequent beauty of the temples as regards their *quantities*; and I think that any fixed proportion between the diameter and the height of the column could not be invariably maintained, Japanese temples being seen under such different



conditions as to make a hard and fast rule of this kind impracticable.

Many of the temples are situated on eminences, and are seen

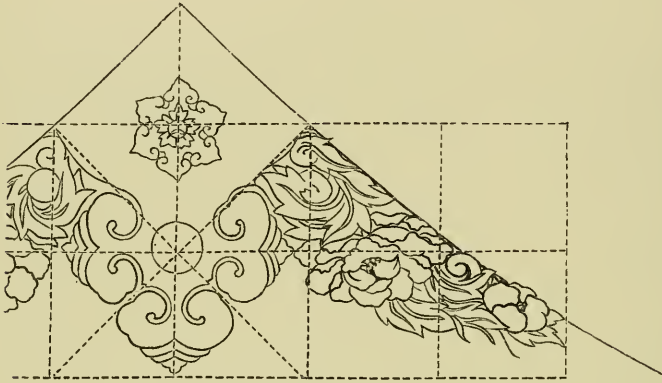

FIG. 104.—DIAGRAM OF ORNAMENT IN GABLE.  
Showing the manner in which the proportion of its parts is determined.

chiefly from below ; while the columns of those which are placed on level ground are in part hidden by overhanging roofs. Some,

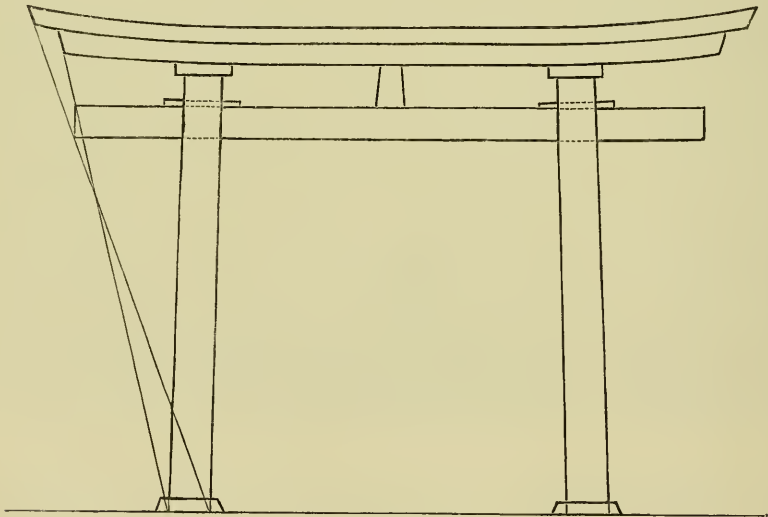

FIG. 105.—TORII. Showing the manner in which it is "set out."

which are enclosed by a series of courts (as the temple at Nikkô) must be so closely viewed, owing to the proximity of

the surrounding walls, that the proportion of part to part can scarcely be perceived.

In Japanese buildings all the parts of the structure are held together by a system of "dovetailing," neither nails nor screws being used in their production, except for ornament. A grand ornamental nail, with a head three inches in diameter (see Fig. 36), is often placed in a horizontal timber, immediately over the window slides of a house, but here it serves no structural purpose.

Some of the "dovetail" joints are most complicated and remarkable, for they have to bind the parts, coming in three or four directions, together.

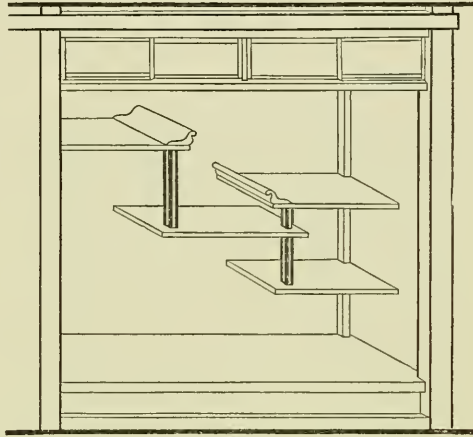

FIG. 106.—JAPANESE CUPBOARD OR CABINET.

With the view of showing in a very

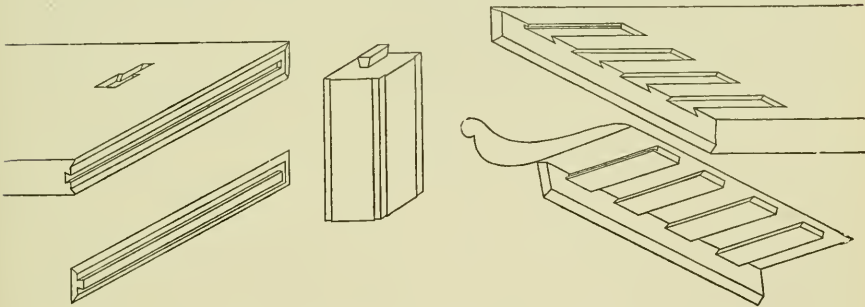

FIG. 107.—DETAILS. Showing the manner in which the parts are dovetailed together.

simple way the construction of Japanese houses, I copy some working drawings from a native book (Figs. 108, 109, and 110).

While there is no furniture in a Japanese room, there is generally a little arrangement of fixed shelves in a corner, on which objects may be placed. The manner in which the parts

of such a structure are put together, will be understood from the accompanying illustrations (Figs. 106 and 107).

We now see that Japan has produced a system of architecture eminently suited to the wants of those who have called it forth, and peculiarly adapted to withstand the earthquakes

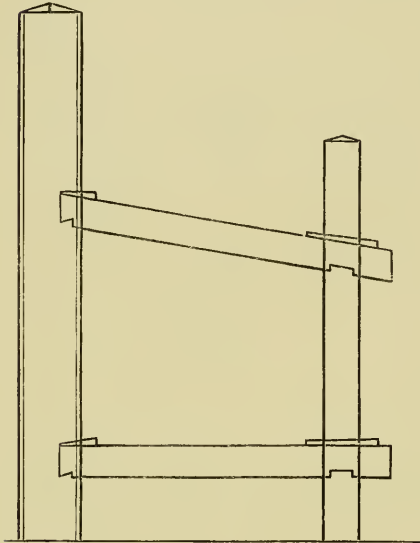

FIG. 108.—GATEPOST AND ITS SUPPORT. Showing the manner in which parts are put together.

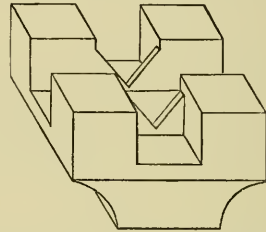

FIG. 109.—TOP OF A BRACKET. Showing the manner in which tie-beams are held together.

to which Japan is so subject. We also see that this architecture has sprung from a primitive dwelling; that its character has been modified

by the introduction of special features from Continental Asia; and that religion has played its part in determining its character. We further notice that out of the architecture has grown a system of ornamentation, developed under the influence of Buddhism, while the perfect finish of all Japanese work is due to the influence of Shinto upon the Japanese mind.

The ornament which has arisen in association with architecture has been applied to objects of domestic use, as works in lacquer, earthenware, fabrics, etc. But liberties are taken in dealing with

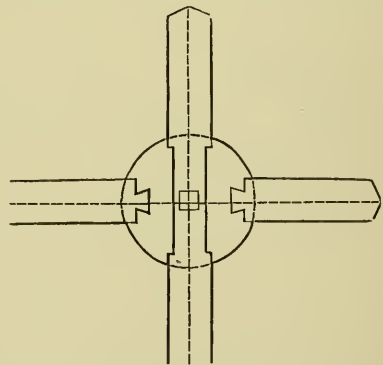

FIG. 110.—TOP VIEW OF CIRCULAR PILLAR. Showing the manner in which cross-beams are inserted into it.

common wares which would not be permitted in the case of architectural edifices. Yet I have seen a monkey, carved in a humorous manner, resting upon a temple roof, as though it were sitting there; and a cat modelled on the tiles of a house. But here we have quaintness similar to that of the grotesque European gargoyles of the Middle Ages.

In the case of fabrics we have patterns of most extraordinary kinds. Thus, before me, as I write, is a dress-cloth figured with brooms, rakes, and the leaves that are to be gathered up (Fig. 111). Here is another formed only of long-legged water-flies; another consisting only of children in all conceivable attitudes (Fig. 112). Milestones, rabbits, birds, cobwebs, hats, and all sorts of objects may be found in the patterns of their fabrics; and on a lady's scarf telegraph posts and wires may be seen conspicuously figured (Fig. 188).

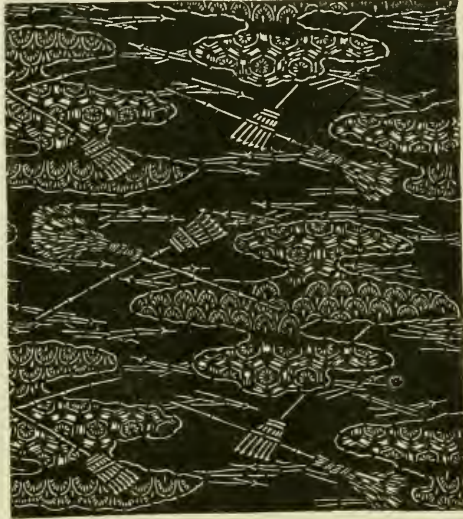

FIG. 111.—PATTERN OF A PRINTED DRESS FABRIC, CONSISTING OF THE LEAVES OF THE FIR-TREE, RAKES, BROOMS, AND DIAPER PATTERNS.

We shall scarcely understand Japanese art unless we remember that the Japanese are a simple and humorous people. They enjoy a joke as much as a child, and there is a simplicity about their manners which has all the frankness of infancy. Indeed, we have here the charm of childhood preserved in grown man. This being the case, we must look for the expression of humour in their art, whenever opportunity occurs; and humour and grotesqueness are closely allied.

During the year 1880, *The Furniture Gazette* gave an illustration of a Japanese dish on which were figured octopii performing as acrobats. On a ladder was one which stood out at right

angles, holding on by his tentacles, while two were performing on musical instruments, and a fourth watched the performance fan in hand. The whole was as comic and grotesque as it could possibly be (Fig. 113). Teapots made in the form of birds, frogs, and fruits, owe their origin to this sense of humour; and a

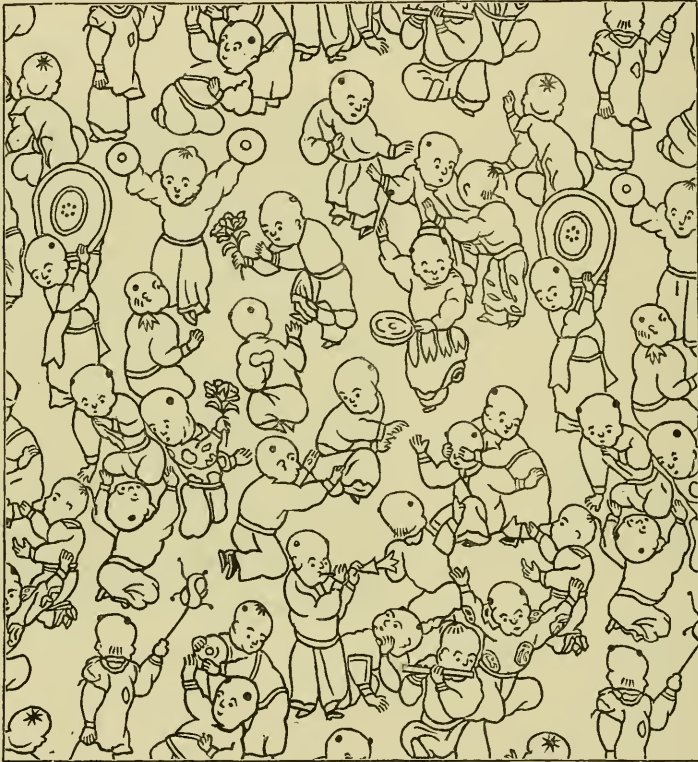

FIG. 112.—PATTERN OF PRINTED FABRIC, CONSISTING WHOLLY OF CHILDREN AT PLAY.

thousand things might be named as illustrating in Japanese art this love of the comic. The battle of the frogs, the grasshoppers' procession, and such subjects, are so well known that we need not here enumerate them.

Many Japanese patterns have a significance to those for whom they are intended which is not apparent to us. Thus the almond is the type of beauty, as we have before said, and the stork (which

is said to live a thousand years) of long life. In Japan a dead stork is as rare as a dead donkey is here. The tortoise is another emblem of longevity, for it is said to have a thousand lives, and another is the peach, for a man who lived for nine hundred years ate this fruit as his chief food. It is strange that, though they are so fond of portraying storks and drawing them in every conceivable attitude, during the whole time of my sojourn in Japan I never



FIG. 113.—DISH MADE IN TOKIO.

saw but one living specimen of this bird. Owing to the numberless representations of them which we see on Japanese works, I used to think that storks must be almost as common in Japan as sparrows are in England; but this proved to be a great mistake. The Japanese are also fond of portraying the domestic cock and hen; but these, like the mandarin duck and drake, symbolise connubial felicity. On an early Christian tombstone in the catacombs at Rome, two birds are represented looking at one

another, which are said to be cocks fighting. To me this seems most unlikely, and I believe them to be cock and hen, and not two male birds, as is generally supposed; and inspection will show that the one bird only has hackles on the neck.

Another form which should be noticed is the two-edged sword, which is a divine symbol. The gods of Japan wore and wielded two-edged swords; and from the tail of the dragon was born the sword which the sun-goddess gave to the first Emperor of Japan.

Here we have a symbol with which we ourselves are familiar. In the Apocalypse we have the expression: "These things saith he which hath the sharp sword with two edges;" and again the words: "And out of his mouth goeth a sharp sword, and with it he should smite the nations." Curiously, in the Japanese myth, the sword is associated with a serpent-like creature who gave it birth, while the sword in the Apocalypse proceeds from the mouth of the King of kings and Lord of lords.

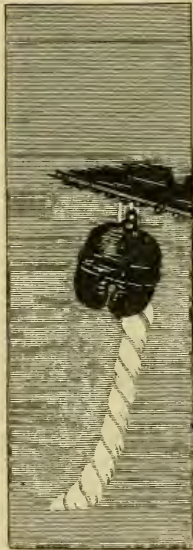

FIG. 114.—PATTERN  
OF A JAPANESE  
TOWEL.

Some Japanese patterns exhibit subtle satire. On a figured towel there is a curious split bell-like gong dropping from the eaves of a temple roof; while in front of it dangles a large pendent rope. When the Japanese goes to the temple to pray he takes the rope in his hands, and by giving to it a sharp waved motion causes it to strike against the gong. The sound thus made, he believes, calls the attention of the god to the supplication about to be offered. In the pattern of the towel before us the gong

is loose, for the devotee, in his anxiety to secure attention to his prayer, has hit the gong with such force as to detach it from its support; thus it is falling to the ground (Fig. 114).

On an old Kioto bottle in my possession is a skeleton holding a long bamboo rod, on the end of which is a bird; while an almond-tree, the symbol of spring, of youth, of beauty, and of long life, occurs behind the rod to which the bird is attached.

The satire of this design will be understood when it is remembered that the Japanese catch birds by darting at them a bamboo rod, on the end of which bird-lime has been placed. Those so-called fishing-rods, the joints of which blow out, and which are now so much sold in England, are made by the Japanese as bird-catchers. To be caught is death to the bird, hence the skeleton holds the rod by which the bird is caught, although this may be the time of its youth, and its spring. The reference to long life is mockery! Fig. 115 represents a netsuki in which the thought of summer, or abundant life, is given—both animal and vegetable.



FIG. 115.

A great number of the little "set" devices which we see upon good Japanese objects are crests, or heraldic insignia, and these have a significance similar to our armorial bearings (Fig. 116). But it is impossible for me to do more than call attention to the nature of Japanese ornament generally. A detailed examination would need a volume.

If we consider Japanese art broadly, and include carving, painting, and decoration, we shall see that much of its interest is due to the expression of poetical feeling. On a towel we see, as a pattern, a panel in which is a full harvest moon, with a few sprays of grass in front of it (Fig. 117). And on a cabinet the large full autumn moon, with grass-sprays laden with silver dewdrops. In both cases the pleasant autumn evening is brought to mind, and the softly-flowing stream beside which this tall grass grows. On a vase we have the well-known hawthorn pattern, which represents cracked ice, with the plum blossoms upon it that have been pinched off by a late frost.

Many Japanese designs are of a legendary character. The Japanese speak of the "hare in the moon" as we speak of the "man in the moon." They regard the dragon as "the



demon of the storm," and picture the tempest both in air and in water as the elements agitated by this monster. In Fig. 118

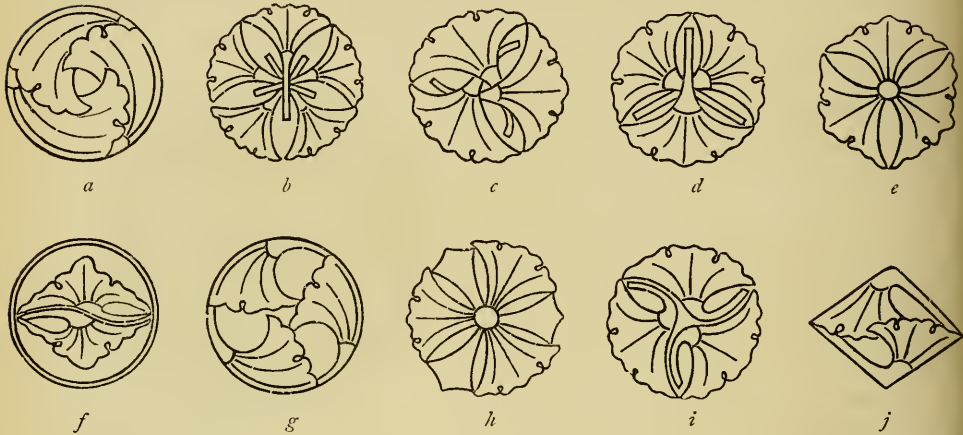

a thunderstorm is represented, with the god of Thunder and his

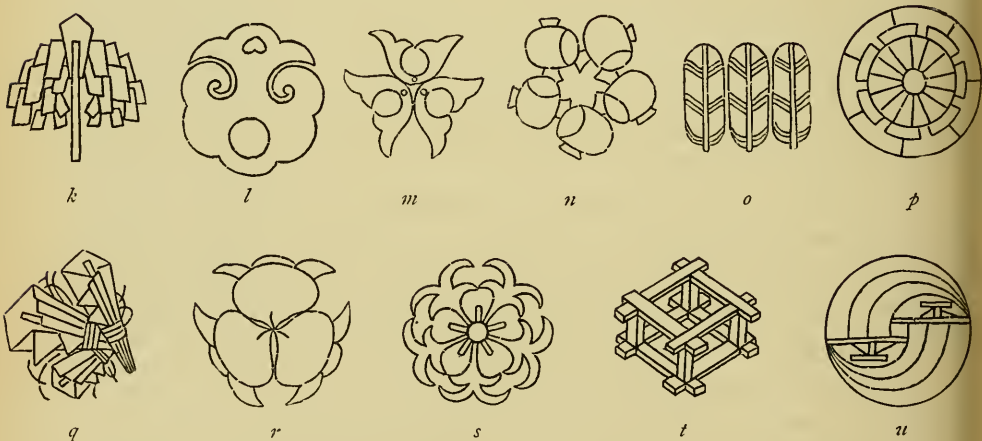

FIG. 116.—JAPANESE CRESTS. Those lettered from *a* to *j* are all formed from the leaf of the Maidenhair tree ; *k*, from the Go-he, or cut papers, used as the symbol of the Shinto religion ; *l*, from a kind of gong ; *m*, from the heads of a kind of arrow, used in warfare for cutting ropes ; *n*, from five hammers, such as the god Daikoku bears ; *o*, from three hawk's feathers ; *p*, from a cart-wheel ; *q*, from three of the folded papers which indicate that an object is a gift ; *r*, from three rabbits ; *s*, from five anchors ; *t*, from the wood-framing around a well ; and *u*, from two sails of a junk.

circular drums in the air, while from the cloud descends both forked lightning and rain. Surely the "key pattern" did not

originally signify the lightning which the people feared! They depict a fish leaping the waterfall before ascending into the

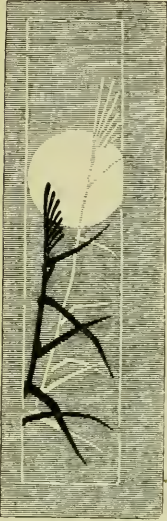

FIG. 117.—PATTERN OF A JAPANESE TOWEL.



FIG. 118.—THE THUNDER GOD. After a native drawing.

clouds as typifying ambition and perseverance. The pine signifies everlasting youth, the bamboo uprightness and usefulness; but to the significance of their patterns there is no end.

Here before me is an ivory carving of two men quarrelling. The one has long legs and short arms: the other has long arms and short legs. The tale goes that fish can only be caught in deep water, where the man with short legs could not stand. The man with long legs can get into the deep water, but, owing to his short arms, he cannot reach to the bottom and fish. The difficulty is overcome by the long-legged man carrying the man with the long arms on his back. The two together can thus catch fish, but neither can do so alone. Hence the absurdity of these men quarrelling. The same idea is conveyed in our expression, "He is quarrelling with his bread."

Japanese carving varies in character according to the purpose it is intended to serve. Those little button-like objects which

are worn pendent from the girdle, and are called netsukies, are frequently delicious specimens of minute work. Some of these, as examples of cutting, have never been surpassed (if even equalled) by any other people, being almost of classic refinement ; others are hugely grotesque, while some are imitative works of marvellous excellence ; but the distinction between imitative and conventional work must not be lost sight of. The imitative may be influenced by the position in which the object imitated is placed, and by the momentary expression which has been seized for perpetuation in the carved work. What we have to consider in such works is the excellence of the imitation, the nature of the surfaces, and those fleeting characteristics of the object imitated which have been embodied by the carver in his work.

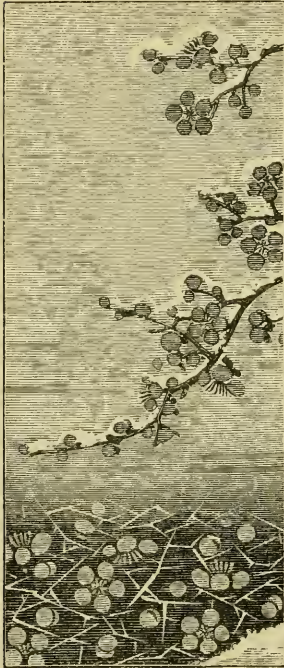

FIG. 119.—ORIGIN OF THE HAWTHORN PATTERN. The late frost nips the Plum blossoms, and causes them to fall on the thin and cracked ice.

Here is a netsuki in the form of a snail, in which the fleshy mollusc, having stretched itself as far as it can from its shell, seems trying to climb to the top of it. The horn-like pedicels, which carry the eyes on their extremities, are fully protruded and rest upon the shell, to which the plastic body of the snail appears to cling ; while the hinder portion is slightly twisted so that its smooth and mucous under surface is exposed from above. In this work the texture of the shell is perfectly given ; the little striæ indicating its successive stages of growth being carefully marked ; while the voluted form and slightly recurved orifice of the shell are rendered with a fidelity and feeling which could not be surpassed. But perhaps the most wonderful quality of this carving lies in the expression of plasticity and mobility which the artist has embodied in his work. The creature clings to the

shell, over which it almost seems to slide, while the horn-like bodies are protruded in a manner so life-like that they might readily be mistaken for members of a living creature. The texture of the body is as good as that of the shell, while the under portion of the "foot" has that strange glabrous surface which makes it appear real.

As a naturalistic carving this little netsuki is almost perfect ; yet the parts of the creature are so disposed that no member is in danger of being broken off. On the contrary, it is all compact, and forms but one mass without excrescences.

This one illustration of naturalistic work must suffice, although it would be easy to multiply illustrations indefinitely. But to take an instance of a somewhat different character, we may consider a netsuki which represents a child, who wears a large mask from which depends drapery, and who is sitting in a crouching position, beating a small drum.

On certain days of the year children go about the streets of Japanese towns with hideous masks on. From the masks (which almost envelop the head) drapery is pendent, and in this the body is enveloped. These children generally have drums, which they beat while perambulating the streets.

The netsuki before us is about one inch in diameter ; and in the hideous beast-like mask the artist has had room for his fancy. The drum is clutched by the feet of the sitting child, and on it rest the two drum-sticks which are held in the hands. But the peculiarity of this work is seen on looking through the open mouth of the grotesque mask : you see a charmingly cut child's face, with little jewelled eyes inlaid ; yet no trace of any join in the wood can be discovered in the work.

The two illustrations given of detailed carving are of exquisite finish ; but another class of work for which Nara is celebrated differs essentially from those objects of which I have just spoken. These consist of a number of small flat facets, each resulting from one clean cut. These works would almost represent what is going to be a finished carving in its "blocked out" stage.

One such netsuki of a humorous character represents on one

side the face of a Court lady, while if it is turned round there is the face of a gentleman, who is furnished with large ears and small tusks, and who, if his entire body were represented, would probably have a tail and cloven hoofs.

The Japanese, like other people, will have their little joke, although in this case it is severe on the Court ladies: for the inference is that when seen in one view she is a lady, but when in the other she is a very ——.

Between these two classes of carving we have an intermediate stage, in which we have great crispness of treatment and precision of work, together with high finish. But this intermediate method is not so general as the other two.

Purely ideal productions, it needs scarcely be said, must be judged, not by their imitative qualities, but by their merits, as decorative works. As an illustration we may take a netsuki, which represents the spotted lion, or King of the Fauna. Here we have an ideal beast—a grotesque. This work we have to regard as a mere decorative composition. We have to view the various curls of hair constituting the mane of the beast, and the spots in which they terminate; we have to consider the arrangement of the limbs, the treatment of the tail, the expression given to the creature, and the decorative distribution of the parts in their relation to ornamental effect only.

This little netsuki is as interesting in its way as the snail was as a naturalistic work; for it is decorative, ferocious, and grotesque. The queer grin on its face, the eyes which peep from under overhanging eyebrows, the curious arrangement of the mane, which surrounds the head almost like a grandmother's nightcap, and the beautiful hair-like texture of the body, give to it characters which stamp it an excellent work. As mere achievements, mention should here be made of microscopic carvings, which are common. Thus, as we have already seen, you may meet with two gods carved in wood, and yet so small that both are contained in the husk of one grain of rice, while an entire celestial family may be found in the shell of a common hazel nut.

If we now pass to the larger carvings, such as are used in the

decoration of temples and in positions which compel the observer to view them from a distance, we shall find that they are treated with masterly boldness and simplicity. One of these carvings is given in Fig. 62 ; but the scale of our illustration is too small to show the true character of the work. In modern furniture we often fall into the error of producing carved work so fine that its decorative value is lost. The Japanese rarely make such a mistake, for they have hit upon the happy method of introducing just that amount of detail into the work which can be perfectly seen when it is in its proper position. They "generalise" with a skill which is almost wonderful.

The temples of Shiba and Nikkô, as we have already seen, are adorned by many carvings of birds, flowers, and animals ; and while these representations of objects are more or less natural, there is yet a simplicity and conventionality in their treatment which shows how perfectly the Japanese can seize the salient qualities of an object and can discard all unnecessary detail.

The tendency of those natural forces which result in the growth of plants is to produce in most cases leaves with symmetrical halves and flowers with radiating parts ; but the tendency of all outward influences acting upon plants—as wind, rain, light, and heat—is to cause a departure from the normal type.

The pictorial artist avails himself of the utmost variety, but the decorative artist has often to seek simple and symmetrical forms.

The Japanese well know the value of simplicity and even symmetry in decorative objects ; and the flowers which seem to be pictorially grouped in their best carvings will almost invariably be found to have symmetrical halves or to consist of regular radiating parts. The same remark will apply to the leaves, while in both cases the simplest expression of the object copied is always given.

From Japanese architecture, ornament, and carving, we must turn to their drawing, and seek to understand their methods of work ; for there is much worthy of our best consideration in the results achieved by Japanese artists, as well as in the means by which the end is gained. To me it appears that Japanese child-



FIG. 120.

ren learn drawing almost without being aware that they are doing so. While children are learning to form the letters of the alphabet and the numerals they are also learning to draw. After a few weeks of school life they have acquired the power of making certain shapes (called letters and figures). Here their education in drawing ceases with us, unless they should at some future time be taught to draw as a separate accomplishment. The Japanese not only employ a native alphabet, but they also use a large number of Chinese characters—a number so great that Mr. Sato (the well-known Japanese scholar), though acquainted with six thousand such characters, said that he had never seen a native newspaper without finding some that he did not understand.

When we consider that writing is only a

means for the communication of ideas, the vast amount of time consumed in acquiring such a power can only be deplored. Yet it has a great advantage; for in imitating new characters during every day of his school life, the Japanese child is constantly learning to draw. Again, the child never rests the paper on which it writes upon a desk or table, but holds it in the hand. Thus the whole arm works and not the hand only. Motion is got from the shoulder, the elbow, and the wrist alike. Another feature in the education of the Japanese child which is calculated to influence the character of his work, should he ultimately become an artist, is the fact of his writing with a brush, and not with a pen or point. Then the paper on which he writes is more or less bibulous, so that the instant he touches the paper with his brush the ink (always Indian ink) is absorbed.

This writing with the brush, and this unrestrained use of the arm, gives a freeness to Japanese drawing which can never be got by practice with the point; while the absorbent quality of the paper induces a precision of touch which our method fails to secure. And this power of drawing, this freeness of motion, and this precision of touch, are all got without the child even knowing that he is acquiring the most valuable aids to a high drawing power.

To me our method of teaching drawing seems altogether wrong. We first give to a youth a hard point and teach him to imitate forms by the agency of this unpliant pencil. After he has got into the way of using this hard point we give him a brush, which he naturally uses as though it were something hard and unyielding. He should first use the brush, and when he has acquired its free use he might then be trusted with the crayon or the pencil. By this means he would gain the free use of the point and the brush; whereas by our method the free use of both is impaired.

Their method of writing leads the Japanese artists to dispense altogether with the maulstick; and however minute his work—and no people can draw more minutely or with greater tenderness than the Japanese—the lines are drawn with a brush, and the



hand has nothing to rest upon. Fig. 121 gives a copy used for teaching the drawing of the bamboo.

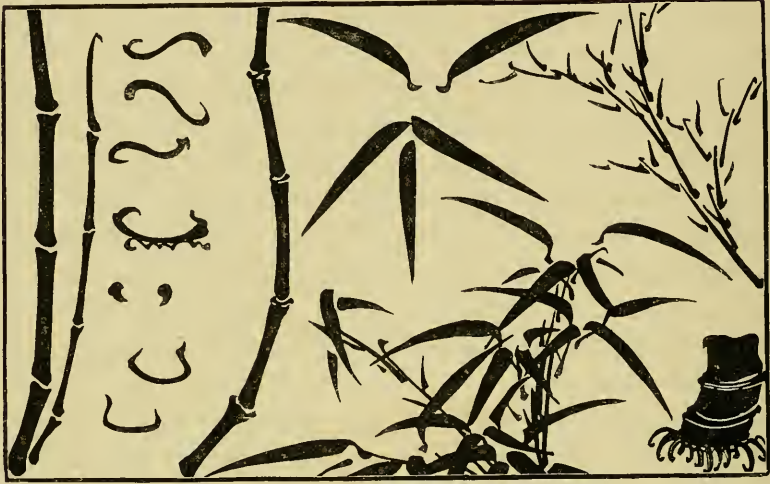

FIG. 121.

The absorbent character of the Japanese paper not only gives precision of touch, but also leads to the simplest form being chosen for the expression of an object. The Japanese thus acquires knowledge of the value of touches, such as no other people possess. But, in order to make myself understood, I must refer to certain illustrations which have been drawn by Japanese artists and engraved by Japanese engravers: for I felt that no European copy of their works would adequately represent the true spirit of their productions. Through the indulgence of my publishers, I have got a number of my illustrations prepared in Tokio: and for these I am much indebted to the kindness of Mr. Yeno, the late Japanese minister in London. It must not, however, be supposed that these are altogether original works, for this is not the case. They are copies, by excellent artists, of illustrations in some of the best Japanese books. To insure their being sharp, it was thought better to have them redrawn and re-engraved rather than have *clichés* from old blocks.

As an illustration of free drawing, I may refer to Fig. 133,

which, in my judgment, could never have been produced by an artist who had learnt to draw with a point. And here we have a feature which has never been admitted in our academic system, namely, the admixture of solid black with outline drawing; yet



FIG. 122.

it must be admitted that the contrast between the solid and the outline is very pleasant. As illustrations of the simplicity of treatment which the Japanese conditions induce, I may give Figs. 120, 122, 123, and 124, where in one example we have a plant touched in with solid black. Another is shown partly in black, and other two in outline only. Of these the most successful are the coltsfoot (Fig. 122) and the pink (Fig. 124); for the



FIG. 123.

characters of both are perfectly given, while the means by which the effect is achieved is most simple. The rendering of the withering cotton plant is also worthy of special commendation.

Another merit of Japanese drawing is its crispness of touch; or angularity. Rounded lines, if used in a sketch, generally produce feebleness of effect: whereas angularity in drawing gives vigour and life.

Japanese drawings have in a high degree this crispness of character, and Figs. 125 and 126 will illustrate what I mean. The lily is grandly drawn. The sweep of line, the precision of touch, and the crispness of its rendering, make it charming to the artist: and the little bits of grass, which mingle with its leafage, destroy that hardness which the sketch, in their absence, would have.

Clever as the sketch of the lily is, that of the



FIG. 124.



FIG. 125.



FIG. 126.



海棠

FIG. 127.

U





Fig. 31.

百鶴の図



Fig. 32.



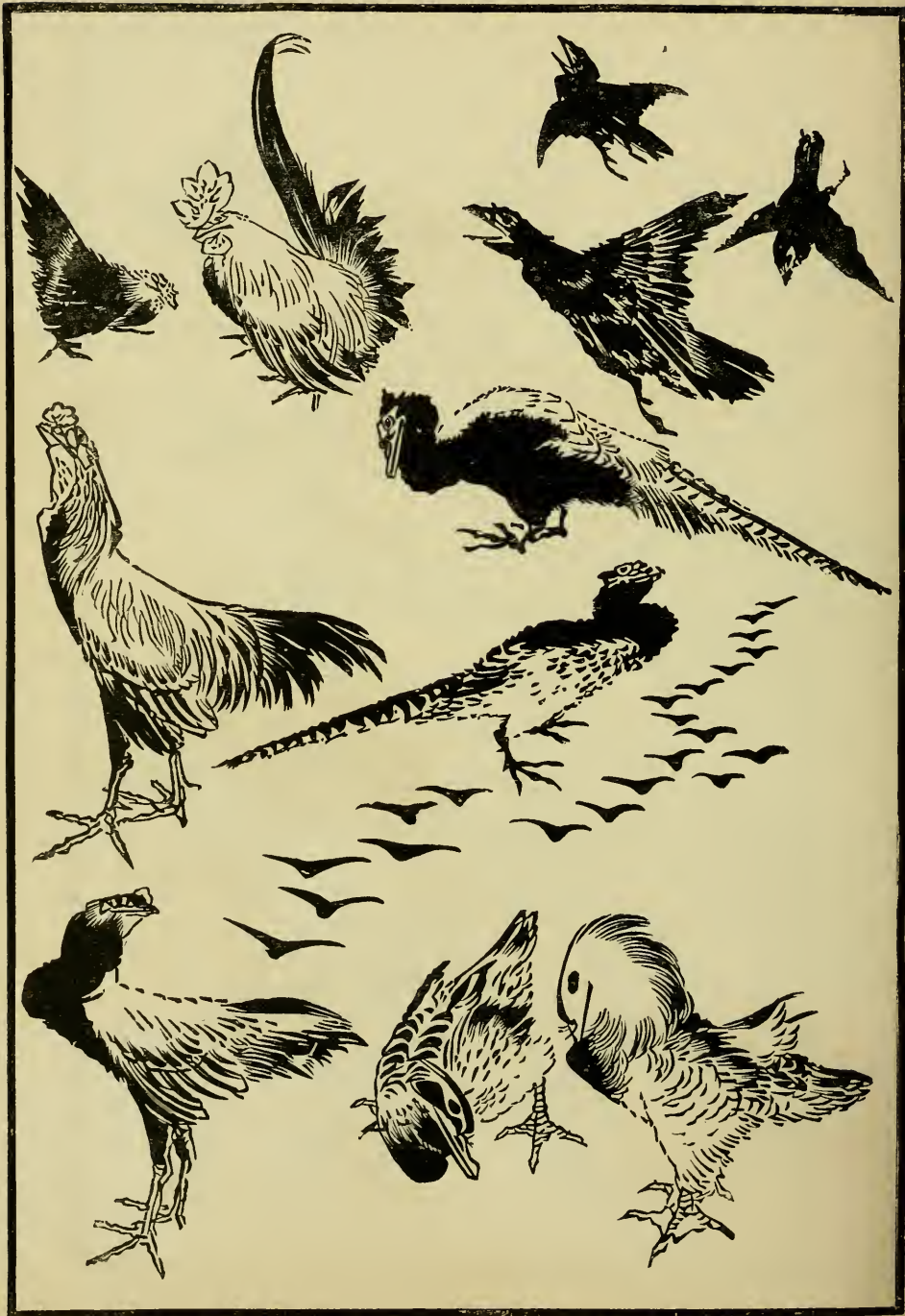

FIG. 129.



FIG. 130.







FIG. 132.



蒲公

櫻草

FIG. 133.





FIG. 134.





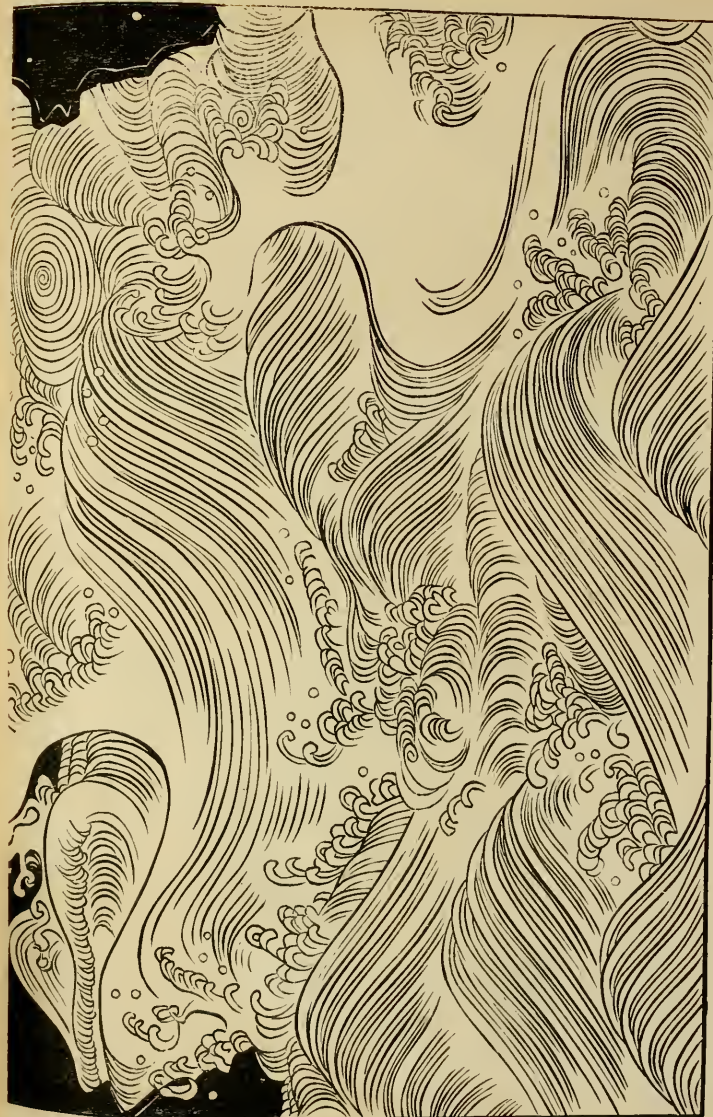
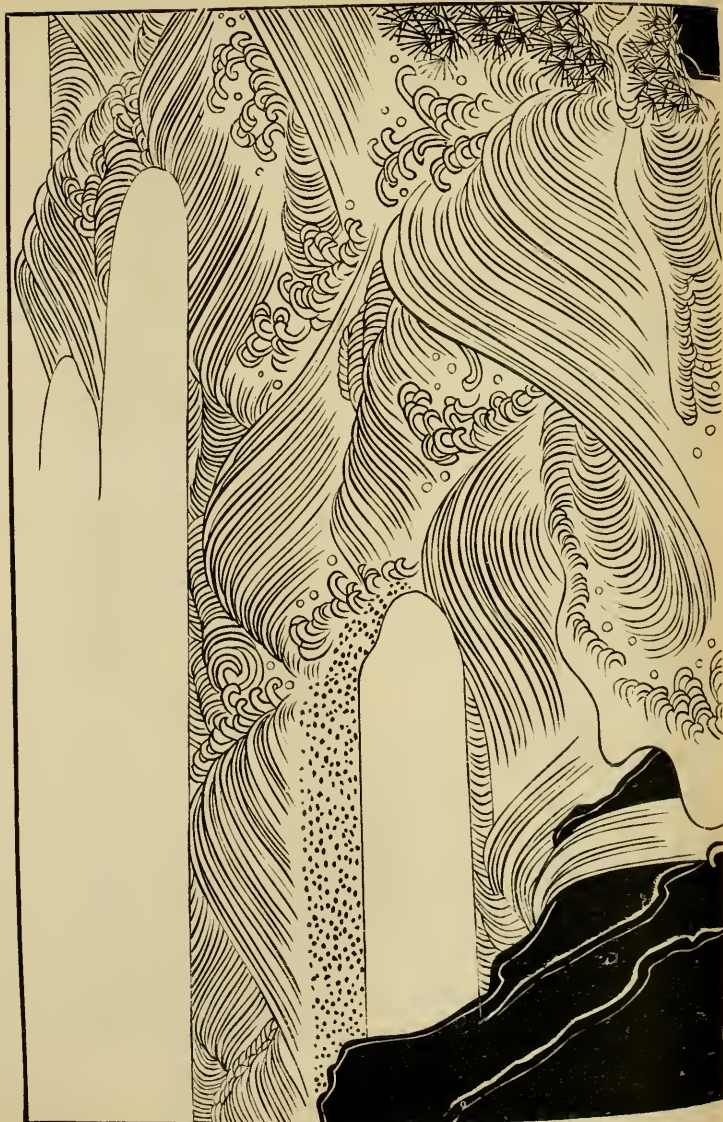

FIG. 135.

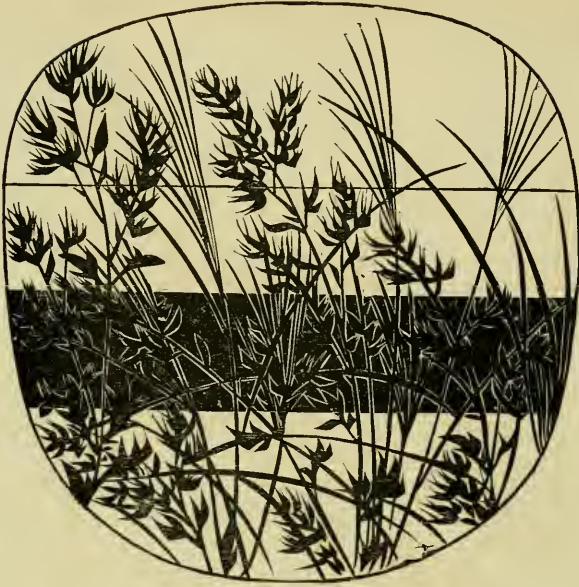

FIG. 136.



FIG. 137.



FIG. 138.



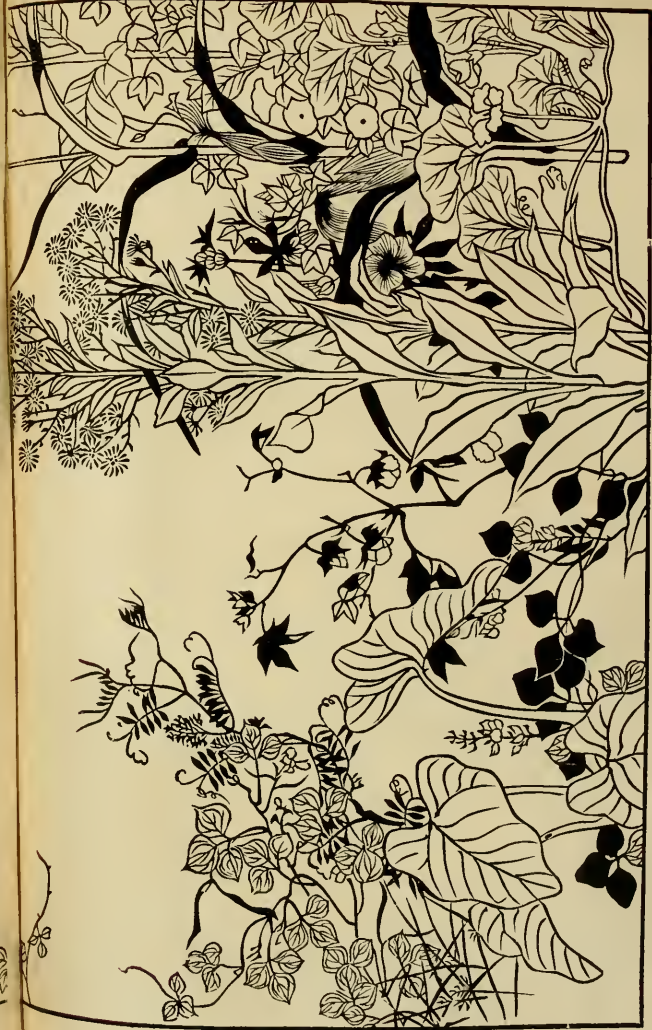
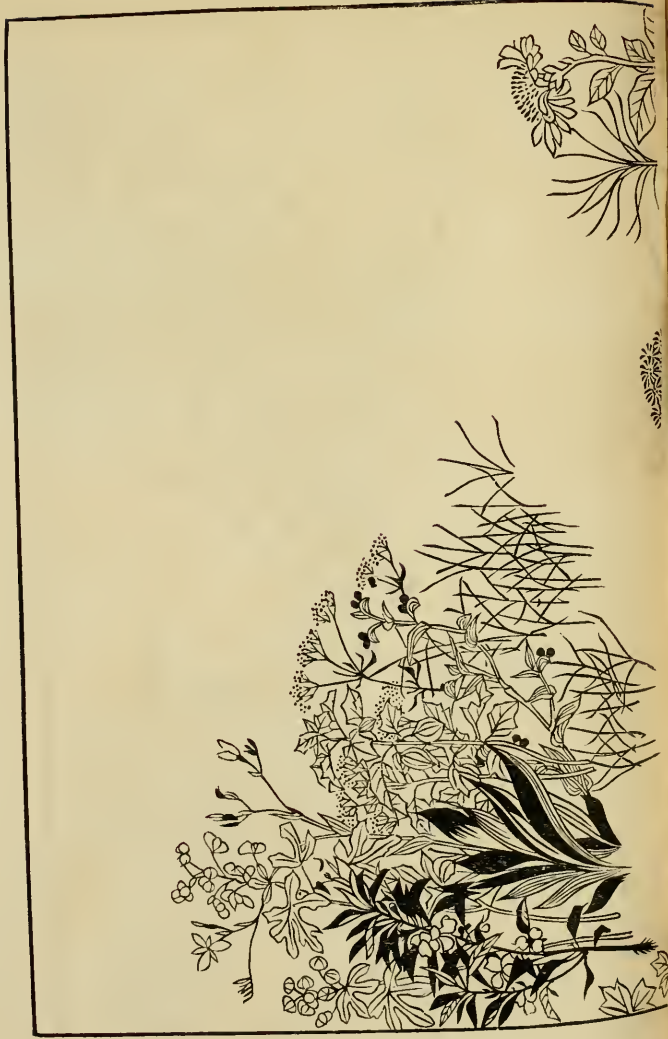

FIG. 139.









牡丹臺 ウツナ



ハナツボミ  
花苞

牡丹花辨





ハナメウ  
カ  
花萼草



ノ  
フ  
ジ  
ソ  
ウ  
野苺草



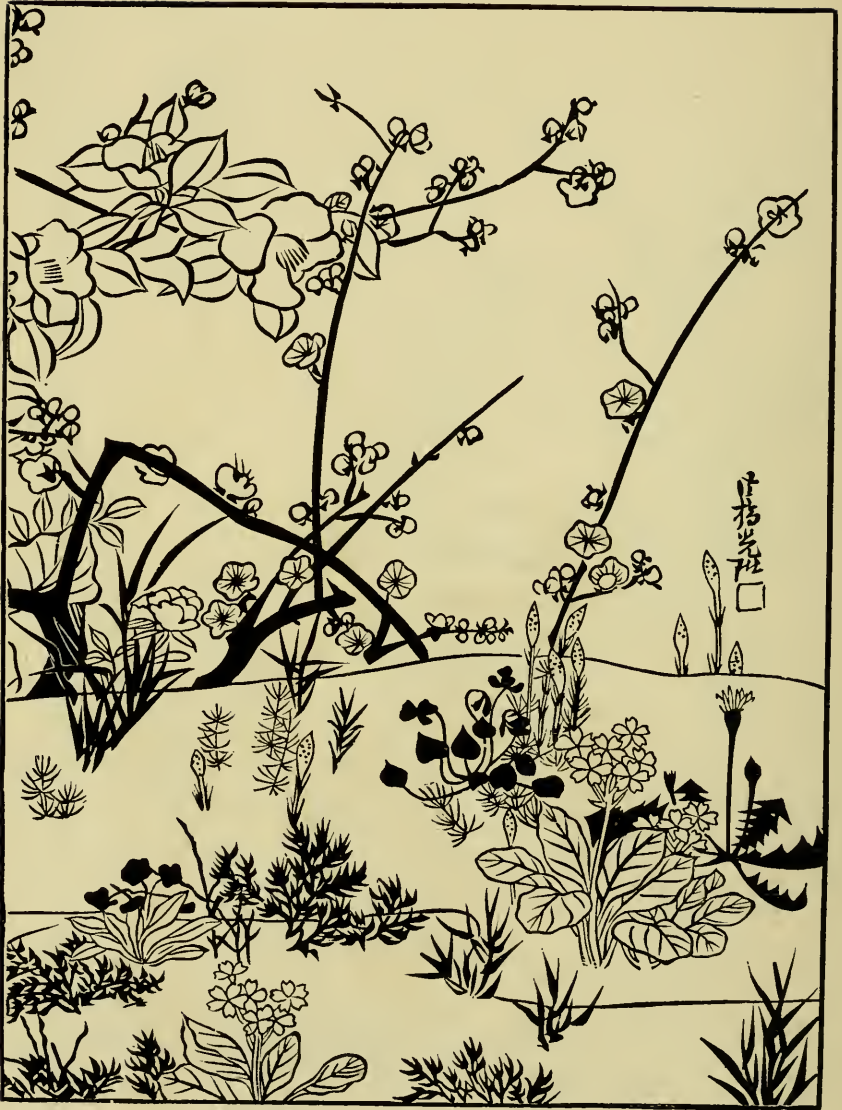

FIG. 143.



FIG. 144.



FIG. 145.



FIG. 146.



wisteria creeper is scarcely less meritorious ; for the angularity of its leaves, the free winding of its stems, and the firmness with which the buds jut out from the parent stem, gives an impression of life which no other treatment could achieve.

My illustrations have, so far, been drawn exclusively from the vegetable kingdom ; but birds, fishes, crustaceans, insects, animals, and human figures might be selected, which would equally well illustrate those art qualities of which we are now treating. With the view of showing how these principles apply, I have had illustrations from other kingdoms of nature than the vegetable prepared. In Fig. 147 we have a crisp drawing of drapery which is both characteristic and good. No one who has seen a Japanese girl, full of pride in her best clothes, going along the streets of Tokio, could fail to be struck with the excellence of this slightly caricatured rendering of so important a personage : but we give it as an illustration of a method of drawing which has great merit. Although the solid black which is here used as hair would not be allowed in our schools of art, I cannot help thinking that it tends to separate the head from the drapery ; and that it is of value to the drawing. Fig. 146 gives a drawing of the god of wisdom.

Various crabs, which we also figure, show charmingly the simple manner in which natural objects may be expressed (see Fig. 131) ; and on pages 292 and 296 we give drawings of the same simple character of birds.

In art, nations are characterised by peculiarities of grouping and of treatment. The peacock on page 289 is treated in a manner so characteristic of Japan that no one need look at it twice in order to say what people produced it ; and the grouping of the birds on pages 290, 302, and 306, is equally characteristic. But there are other peculiarities of treatment, in which the Japanese indulge, which are well illustrated by Figs. 134, 135, and 138, where black is introduced in a strange and abnormal manner. Yet these illustrations are so full of interesting work that they demand careful study, even if we do not approve of the treatment here adopted.

There is yet another feature about some Japanese drawings

which should not be passed unnoticed — I mean the treatment of foreground of which Fig. 143 gives us a good example. Here it will be observed that the front part of the picture is formed of the violet, primrose, dandelion, equisetum, and other plants, rendered with a conventionality which reminds us of our early stained glass, and many old tapestries. Whoever originated this method of treatment, it is certain that it characterises Japan as much as it does the works of our own country.

We have seen that the drawings of good Japanese artists are simple in expression, crisp in character, and conventional in nature. But there is a quality which their works possess that transcends all other merits, great though they be; this is the expression of life with which they



FIG. 147.

endow their delineations of plants, birds, insects, and fishes ; and no other people can make drawings live as can the Japanese.

When we draw a bird, we are content to imitate its form ; and either to produce the general effect of the object copied, or to portray laboriously every detail of the creature. The Japanese artist, on the contrary, by a few simple strokes, produces a bird which appears to live ; it pecks (Fig. 137), it flies, it rests in dignified repose, or it is eyeing its prey. There is life in his rendering of birds, while ours are inanimate objects bearing but little more relation to the living thing than waxworks do to human beings.

Their drawings of fish, crustaceans, and insects have equal life with their representations of birds. They can make an insect appear pleased, a crab look as though it smiled, a herring wag its tail with delight, or an octopus perform on a musical instrument, and yet seem natural ; in short, they appear to know the ways of birds, insects, fishes, and other things ; and to be able to make themselves feel as these creatures do.

In their representations of plants there is also manifested that keen perception of individual qualities and subtleties of form which we notice in their delineations of other things. Intense love of both nature and their art can alone account for the life-like vigour which characterises so many of their works.

Those who judge my remarks by reference to the common objects which are now to be seen in the windows of many of our shops may be disposed to question the accuracy of my statements respecting the merits of Japanese art ; but while some of these goods (produced by the thousand for the European market) bear patterns in advance of any that Birmingham or Wolverhampton can produce at a similar price, it would be almost as fair to judge of English art by the landscapes seen on our common tea-trays, or papier-maché blotting-books, as it would be to judge Japanese art by such specimens.

So much importance do I attach to the influence of Japanese drawings upon English art, that I am led to crowd this part of my book with native illustrations, (see Figs. 130, 137, 138, 141,

142, 144, and 145), although some may seem superfluous. But I cannot too strongly recommend our young ornamentists to consider these drawings, and to try and acquire the Japanese power of delineating natural forms with simplicity ; nor can I too strongly commend to him the use of the brush in preference to that of the pencil.

But I must not be misunderstood : I do not wish to destroy our national art, and substitute for it the Japanese style. I merely wish that we should avail ourselves of those methods which are in advance of our own ; not minding where they originated. Art, to be of value, must be national. It must embody the sentiments of the people who create it ; hence no foreign art can be adopted by a country without the sacrifice of qualities which make it noble. A nation may borrow art suggestions from other peoples, as the Greeks borrowed from the Egyptians, and as the Japanese have borrowed from the Chinese even with advantage. But the suggestions adopted must be filtered through the mind of the country that adopts them. They must be so modified as to harmonise with the new conditions under which they exist. Broadly stated, my position is this—we may borrow what is good from all peoples ; but we must distil all that we borrow through our own minds.

Thus far we have only spoken of sketching in black and white, and have made no mention of painting in its truer sense ; but Japan knows no art similar to that by which we produce our great pictures. The Japanese have no method of “working up” an effect : they cannot heap up labour upon a subject, and cover a canvas with colour as we do. Indeed the best Japanese art consists of perfect sketches, and not of works which we call “finished.” As sketches some of the Japanese coloured drawings are beyond all praise. They are vigorous, simple, and life-like ; while the colour is distributed with the greatest possible care and understanding—understanding of quantities, understanding of harmonies, understanding of the value of shades. Japanese drawings are at best but sketches ; but though I am a sincere lover of our own school of pictorial art, I have yet seen works by

Japanese artists which I would prefer to many an English picture which has cost hundreds of pounds.

As in the narrative part of my book I have already spoken of Japanese artists and their work (see page 58), I need say no more about them ; for whether the works are in black and white, or in colour, we find that simplicity of treatment, that angularity of drawing, that quaintness of rendering, that exquisite grace (see Figs. 125, 139, 144), and that life-like character (Fig. 130) which makes all their better works so charming for those who can appreciate high art qualities.

## CHAPTER II.

## ANALOGIES AND SYMBOLS.

BY the agency of language something has been done in the way of tracing the wanderings of mankind and the affinities of races ; but I am not aware that decorative forms have been used, to any material extent, as a means of arriving at similar knowledge, although to me they seem capable of yielding valuable aid in such inquiries.

That there have been national styles of ornament decisively characteristic of the peoples by whom they were produced is almost a truism : and it is my belief that the ornamental forms and the decorative system employed by a people are of greater value, as ethnological tests, than peculiarities of architecture ; and that they afford a means of determining the relationship and the migrations of races, at least as satisfactory as do the words or construction of a language.

As an illustration of what I mean I may take one or two examples. On many earthen plates which have reached us from Persia we have pure Chinese ornament arranged in a purely Chinese fashion. This, together with the fact that all these dishes bear Chinese "marks," has been a cause of much controversy amongst collectors ; and as the "paste" of which these vessels are made is evidently not Chinese, it could only be inferred that Chinese potters had exercised their art in some foreign country.

When evidence reached us of the fact that these vessels were made in Persia, there was no longer any room for doubt that

Chinese potters had settled in that country and revived the art of potting in the land of the Shah. Further inquiry has shown this to be a fact, and we can now trace much of the history of Persian ceramics from the period when the art was reintroduced into the country. I have in my possession a blue-and-white jar decorated on the sides with the purest of Arabian ornament, while the ends are treated in a Chinese manner, but the work is stamped with a Chinese mark.

This piece was probably made by the second or third generation of the Chinese potters who settled in Persia; and while its author had been instructed in the traditional ornament of his fathers, he had acquired a knowledge of the style of ornament belonging to his adopted home. But in later works we find the ornament becoming more and more Arabian in character, and the potter's mark changed to a Persian signature.

Another illustration of what I mean is afforded by Yarkand rugs, which bear patterns of a curious Semi-Tartar character, and resemble the works of Persia and India on the one hand, and of China on the other. So marked are the characters of these rugs that any one well acquainted with ornament could say from what district they must have come.

Just as the later Persian pottery owes its origin to Chinese potters, so are the wares of both Damascus and of Rhodes due to colonies of Persian potters; and the particular class of ornament found on ceramic works in Syria, and the Grecian Archipelago, bears conclusive testimony to this fact.

The forms of domestic vessels are also characteristic of nations, and the study of such would likewise assist us in building up the history of past ages; but in such an investigation we must be most careful not to confound similarity of form resulting from copying of natural objects common to various countries, with similarity in shapes of wholly ideal origin. Thus, because the gourd form is common in the earthenware of Japan, China, and Morocco, it does not necessarily follow that there was any inter-communication between these countries; for in each country the dried skin of the bottle-gourd is in common use as a domestic utensil.

If we now turn to Japan in order to ascertain the origin of its decorative forms, and consider the way in which past migrations, the contact of races, their commercial intercourse, the



FIG. 148.—OLD SCEPTRE OR BATON, with the head in the form of a cloud.

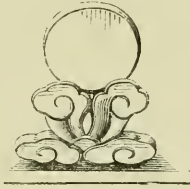

FIG. 149.—UNIT OF ORNAMENT FORMING CRESTING AROUND A HANGING LANTERN IN TOFUKUJI, NEAR KIOTO. It consists of a ball (the sun) resting on clouds.

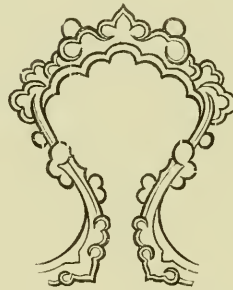

FIG. 150.—PERSIAN ORNAMENT, derived from cloud forms.

visits of missionaries, or other incidents, have had their influence on the world, we should note those ornaments which have been derived from clouds, and probably owe their origin to Central Asia.

The head of the sceptre or baton (Fig. 148) has a form which has been in use from an early period, for in the collection of antiquities at Nara we find two objects of a similar character, the one being twelve and the other thirteen hundred years old.

This particular shape is not only common as the head of a staff, but may be found as an ornament surrounding many Chinese



vases, as the border of certain Yarkand rugs, and, in a modified form, on much Persian work. This is one of the ornaments derived from cloud. But to trace its origin we should have to

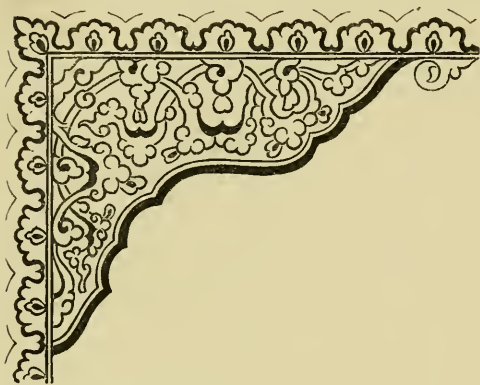

FIG. 151.—PERSIAN ORNAMENT, which owes its origin to cloud forms.

study many examples in which cloud ornament occurs (see Figs. 149, 150, 151, 152, 153, and 154). Persian ornament in its various modifications furnishes many examples of shapes, arising out of an extreme conventionality in the representation of cloud-forms. Ornaments of this kind, I believe, spread from Central Asia

in the one direction through China to Japan, and in the other through India to Spain and Italy, and through these countries to Europe. Cloud ornaments are to be found in all parts of the Continent of Europe, as well as in the early work of our own country.

An ornament of considerable antiquity preserved in the Nara collection and found on the crupper of a saddle belonging to a sacred horse (which for centuries was hidden in a temple so sacred that even a high priest could not enter it<sup>1</sup>) is of special interest. Here we have forms derived from cloud and others from flames,

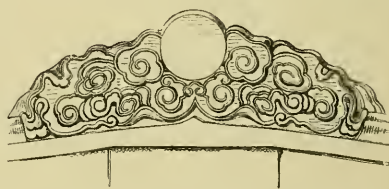

FIG. 152.—ORNAMENT REPRESENTING THE SUN (THE BALL) RESTING ON CLOUD. From over the doorway of a tomb in the burial-ground outside the wall of Canton.

<sup>1</sup> I have seen the temple in which the horse is said to exist, but how this ornament was got out, or at what time it was added to the Mikado's collection, I cannot say; but I am under the impression that I was told by one of the Government officers when in Nara that it was removed from the horse when the present roof was placed upon the building. The roof of this temple in which the sacred horse is preserved is the finest specimen of thatch in Japan, and consists of thin layers of an inner bark of a cone-bearing tree.

while in the centre of the latter we get that singular onion-shaped object so generally found in the grasp of the dragon, forming the terminal ornament of certain forms of pagoda, and



FIG. 153.—CLOUDS AND MOON. By a native artist.

occurring also in the monstrance, and in the great majority of monumental stones found in Buddhist cemeteries (see Figs. 38, 40, 50, 51).

This brings us to an important fact. Much of the ornament which the world has known owes its origin to fire-worship. In the case of the monstrance (Fig. 50, see portion A), and in that of the ornament from the sacred horse, we have both cloud and flame rendered in a decorative manner, and while the ornament of the

latter generally consists of flat pieces of brass, the "jewel" is emphasized by being formed of white metal.

In a work like the present it is impossible to illustrate or discuss fully the facts which I shall have to state; but the conclusions arrived at have resulted from the most careful study of decorative art for nearly thirty years. During this time I have visited nearly all the museums of Europe, as well as some

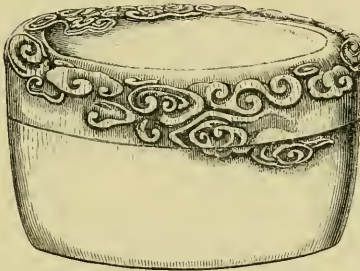

FIG. 154.—CARVED BOX, formed of a root-joint of the bamboo, decorated with ornament having the form of clouds.



FIG. 155.—BRANCH AND LEAVES.

countries of the East which are most likely to throw light on the origin of early ornament. Yet if those who are interested in the inquiry will visit the Indian Museum at South Kensington and first observe the Indian gods with their flamboyant nimbi, and then study Siamese ornament (which owes its forms almost wholly to flames the very forms of which seem to flicker), and will then pass downwards to the more modern examples of Indian work both in metal and fabrics, they will see that the forms which were first flamboyant became gradually foliaceous, and that flowers were introduced at a late period, when the origin of ornament had been forgotten. The cloud ornament certainly does not owe its origin to the vegetable formation to which some attribute it (Fig. 155).

Having argued this matter with that astute observer Dr. J. Lauder Brunton, whose knowledge of ethnology seems only surpassed by his acquaintance with medicine, and who opposed my

theory with vehemence, I went with him to Kensington. After two hours spent in the observation of examples, Dr. Brunton pulled out an old-fashioned gold watch with a richly-chased margin, and, after remarking that my deductions were right, said—"And the ornament around this watch owes its origin to fire-worship." I do not for one moment say that all conventional ornamental forms have sprung from fire-worship, for this is not the case; but I do assert that all my researches have led me to the conclusion that most Indian and some forms of European ornament, as well as forms which are in common use in Persia, Arabia, and Japan, are due to the influence of this early religion.

Perhaps the earliest religion of man consisted in the worship of those things which he feared and yet could not avert—as the wind, which, as a tornado, overthrew his dwelling, uprooted the trees which gave him shelter, and destroyed his crops; the rain, which, when it fell in excessive quantities, produced floods; and fire, which, when it got the mastery, became a veritable destroyer. With this we may compare the serpent worship of India; and, to this day, Professor Owen tells us, the people of the Gaboon district in Western Africa pay a sort of homage to the ferocious gorilla which they all so much dread.

In Japan we find a religion still existing which involves the worship of fire and the sun; and this is accompanied by a high civilisation and the most perfect of arts. Thus, in this strange country we are brought into contact with ornamental forms of a most finished character, which are found associated with the religion to which their origin is due.

There is no doubt about certain decorative forms having been derived from flame and cloud (or cloud-like smoke); but when the flamboyant form first encircled the head of a human effigy as a nimbus is by no means clear. It is said that the ancient Greeks placed a sort of platter, or dish, over the heads of their figures in order to protect them from the weather, and that this is the origin of the nimbus; but Mrs. Jameson referred its origin to the primitive idea that luminous nebula emanate from, and surround, the Divine Essence (Homer, *Il.* xxiii. 205), and gilded rays were

placed by the Romans round the heads of those who received divine honours. There are one or two examples of this form of nimbus still in existence which have come to us from the fourth century B.C.

A large number of those Japanese figures which we find in the Buddhist temples have a nimbus, that of the great Daibutz of Kioto (the largest Buddha of Japan) being seventy-eight feet in diameter; but this is a circular and linear nimbus, while a large number of figures have the flamboyant form, either behind the head or behind the entire body, in the form of the "Vesica Piscis" (Fig. 156).



FIG. 156.—FIGURE WITH "VESICA PISCIS." From the graveyard of the temple Sennichi-kana-butu, Osaka.

My researches in Japan and China enable me to throw no light on the origin of the circular nimbus; but I find in the oldest temples of Nara some curious and interesting modifications of this form. One had a wheel-like character, as it consisted of a peripheral margin, a central boss, and eight spokes connecting the rim with the centre; but on the margin were three tongues of flame, one occupying an upper and central position, while the other two terminated the horizontal spokes. The position of a fourth (should such exist) would be hidden by the figure.

Another nimbus consisted of a ring enclosing a flower with eight petals, the tips of which touched an enclosing hoop, and from a central boss proceeded a number of stamens, and eight sets-of-three wires—the wires being about three times the radius of the circle in length.

When I first saw this nimbus I mistook its centre for a passion flower, and it was wonderfully like some of our treatments of that blossom. The arrangement of the rays so perfectly corresponds with a form of nimbus with which we are familiar that one is

forced to the conclusion that those employed in our ecclesiastical art and those which are so general in Japan have had a common origin.

Buddhism is older by six centuries than the Christian Era, and its diffusion is wider than that of Christianity, being professed by nearly one-third of the entire human race. According to Griffis, it has a literature perhaps larger than that of all other religions combined.

I mention these facts to show the extent of the influence exercised by the religion which has so

powerfully acted upon the arts of Japan; and here I may state my belief that most of the Christian symbols were derived from older religions, and that at some early time there has been a somewhat intimate association between countries now widely separated, and that this association has resulted in the use, through East and West alike, of identical forms.

My reasons for thinking that Buddhists used the nimbus and the flamboyant "Vesica Piscis" before they entered into Christian symbolism are these:—I find them on the images in temples and by the roadside wherever I travel; and some of these images are very old. Buddhism was introduced into Japan in all probability soon after the beginning of the Christian era, but it made little headway until the thirteenth century, when it spread rapidly throughout the land. How old the idols in some of the temples are it is impossible to say, but a number of Buddhist missionaries arrived, together with mathematicians, astronomers, and others, from the Corea A.D. 552, to live at the Japanese Court, and tradition says that with them they brought some of the idols now preserved at Nara and Kioto. But whether these or later missionaries brought the oldest of the idols (many of which are

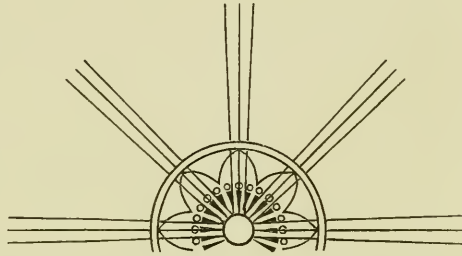

FIG. 157.—NIMBUS OF A BUDDHIST SAINT IN ONE OF THE OLD TEMPLES OF NARA. The flower is formed of hammered metal, and the rays of rigid wires.

obviously of Indian workmanship), and whether the idols were old or new when brought to the country, this is certain, that the great Dai-butzu at Nara was first erected in the eighth century, although the original work was destroyed through civil wars, and was recast in the twelfth century. In its latter form it certainly has a nimbus, and there is every reason to believe that this latter Buddha is a mere copy of that which formerly existed.<sup>1</sup>

Christianity was introduced into Japan in the sixteenth century by Jesuits, who landed at Satsuma; but their work was abruptly ended in A.D. 1637 by the massacre of every Christian in the land. It is said that thirty-seven thousand then perished.

The nimbus could not, then, have been first introduced with Christianity; yet there is the bare possibility that works of the early Christians may have found their way through Central Asia to China, and from China by Corea to Japan. Yet this seems most unlikely, for had such been the case we should surely find other traces besides the nimbus and flamboyant "Vesica Piscis," while the nimbus and Vesica Piscis alone, of all Christian symbols, appear to have reached this country.

There remains the fact, in the words of Griffis, that "almost everything that is distinctive in the Roman form of Christianity is to be found in Buddhism—images, pictures, lights, altars, incense, vestments, masses, beads, wayside shrines, monasteries, nunneries, celibacy, fastings, vigils, retreats, pilgrimages, mendicant vows, shorn heads, orders, habits, uniforms, purgatory, saintly and priestly intercession, indulgences, works of supererogation, pope and archbishops." It is my belief that Buddhism, the older religion of the two, inherited its pageantry, usages, ritual, the rosary, the nimbus, and the "Vesica Piscis," from a still earlier form of worship. I can

<sup>1</sup> Griffis, who spent some time in Japan, says:—"In mediæval times the casting of a bell, or image, a lantern, or any great sacred object, was the occasion of a public holiday and festival, and, for the purpose, the priests asked offerings of gold or silver, personal adornments, mirrors, copper and other metals. At Nara and Kamakura there are the finest results of these sacred offerings. . . . The casting of the idol [referring to the great Dai-butzu at Nara] was the seventh effort, six failures having been made, and three thousand tons of charcoal were used in the operation. The metal, said to weigh 450 tons, is a bronze composed of gold, 500 pounds; mercury, 1954 pounds; tin, 16,827 pounds; and copper, 986,080 pounds."

bring but little evidence to support such a theory ; but I feel confident that research will ultimately show that the circular nimbus has grown out of fire-worship, and that it is nothing more nor less than the sun ; for in certain Eastern drawings we find the nimbus represented as the sun, and the Imperial ensign of Japan is a red ball, which is nothing but a representation of the sun and an outcome of fire-worship. This is also the view of Mr. French, but my own opinion is derived only from the study of Eastern religions and art.

In the ornament obtained from the crupper of the horse at Nara we have in the centre of the flamboyant members a "jewel," and Mrs. Jameson calls attention to the fact that luminous nebulæ were supposed to emanate from the Divine Essence. Now the Japanese speak of the "jewel" as the pearl of great price—a symbol of Divine Essence—a type of the soul of man. Hence the idea set forth by Mrs. Jameson as that of ancients is certainly that of the Japanese.

It is not difficult to conceive an ignorant and superstitious people picturing to themselves a centre or nucleus as the source from which fire emanates, for they might easily think there was a sort of spirit in flame which gave to it consuming qualities. But however this may be, we find this nucleus or "jewel" in the centre of many ecclesiastical flamboyant ornaments.

Figures 50 and 51 represent objects associated with the Buddhist worship which closely resemble the monstrance of the Roman Catholic Church. The one (Fig. 50) was brought by Mamayado, a Chinese prince, in the early part of the sixth century from a temple in China called Koriu as a present to the Japanese. The prince who brought this was born in a stable, as his name implies ; while the other (Fig. 51), which belonged to the temple Ishin in Kioto, was brought by a famous priest called Yenke-Daishi<sup>1</sup> also as a present upon the occasion of his visit to Japan.

These objects are now preserved in the old palace of the Mikado at Kioto, and it was there I had the privilege of seeing them, and to Mr. Kawase, the Minister of Commerce, I am

<sup>1</sup> Daishi is a name given after death to priests of great celebrity.



indebted for photographs of these and other objects of the highest interest.

These works were in gold, and in the Kioto collections many similar objects were of this precious metal. In all cases the "jewel" was formed of a hollow ball of glass. In one instance it contained the tooth of a high priest, and in another metallic lumps found in the ashes after the cremation of a priest. But whatever they contain their interest to us is great; for we find flamboyant ornament, together with clouds, surrounding this jewel in a work dating from the early part of the seventh century. But, besides the interest thus attaching to this object, the works before us show that in the seventh and the thirteenth centuries work equalling anything produced in later times could be done.

In the collections at Kioto there was one of those monstrosities which had their jewels in the centre arranged as a flat triangular pile, here we have the thought of a Trinity—the three sides; but this arrangement does not seem to have been general; and as I do not know the date of it, I must not comment further upon it. In the heraldry of Japan, however, we find a crest consisting of three "jewels" with three tongues of flame surmounting them, and another formed of one "jewel" with the three flames.

On all Buddhist altars we find three bells. One of them has a

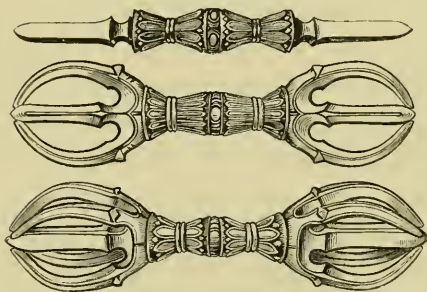

FIG. 158.—INSTRUMENTS HELD IN THE HAND BY A BUDDHIST PRIEST WHEN HE PRAYS IN FRONT OF A CENSER.

handle terminating in a trident; another has the handle ending in five prongs, the two lateral being repeated in a cruciform manner, while the other has but one (the central) prong. There are also on such altars three curious objects, each of which is about six inches in length.

One of these is a double trident, the prongs being at both ends; one has a spike at each end—the central prong; while the other has the five prongs at each end. These the priest holds in his hands while praying

near a censer, and they seem to typify the destructive power of the Deity (Fig. 158).

If we trace the history of these forms we are carried back to remote ages, for not only have we such objects on the monstrance (Fig. 51) from the thirteenth century, where the trident occurs on the lower portion of the stand, and the unident (or spear) on the superposed base, but we have the trident also on the lower portion of the similar object from the seventh century (Fig. 50). In the Nara collection we find an actual object of this kind, only with straight prongs, the central of which has two barbs, while the lateral have but one barb each. In the Kioto antiquities we find an old sword in the shape of this double trident, only with one of the central prongs elongated into a blade.

The authorities at Nara told me that this instrument was originally employed by priests for the catching of madmen; while at a later date it seems to have been used for fighting purposes instead of knuckle dusters. I find it in the clenched hand of some of those diabolical figures which so often guard the gates of Buddhist temples.

When considering this double trident we cannot help noticing the similarity between it and the form by which the Romans represented Jupiter's thunderbolt; and there is probably some connexion between them which we cannot explain.

In the Kioto collection there were one or two examples of tridents arranged in the form of a cross. I was told that these were formerly associated with the worship of Buddha, but that their use was long since abandoned. On a piece of embroidered silk which formed part of a dress brought from China by a Buddhist priest in the early part of the fourteenth century, and which he left to the temple Nanzen in Kioto, we get this cruciform arrangement (Fig. 159).

In looking at this piece of embroidery and comparing it with other objects at this Kioto Museum, and at Nara, which are surmounted with a similar object, notably a bell more than a thousand years old, we could not fail to see a resemblance in form between this trident and the British crown. In the specimen at Nara, we

not only have the five prongs (four of which appear as the bands of our crown), but we have a ball or orb resting where the five prongs meet. I do not, of course, affirm that the form of the



FIG. 159.—EMBROIDERY WHICH FORMED PART OF A PRIEST'S DRESS. It was brought from China in the early part of the 14th century. The figure is called Tokko.

British crown and this Buddhist trident have a common origin, although this may be so; but the likeness is such as to justify my calling attention to it. The form may have originally typified a monarch's power to destroy.

With the view of showing how forms may persist, after the influences which have called them into being have long past away, I may mention a wooden spoon common to this day in Turkey, the handle of which consists of two Byzantine lilies surmounted by a hand. This hand has the third finger approximated to the thumb, as though it were the

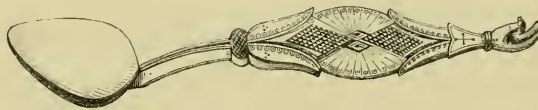

FIG. 160.—TURKISH SPOON, DECORATED WITH BYZANTINE LILIES, GLORY RAYS, AND THE HAND OF THE DEITY IN THE ACT OF BLESSING.

hand of the Deity in the act of blessing the food to be partaken of by the agency of the spoon. At the point where the two lilies meet we have a disc of glory-rays (Fig. 160).

It is curious to find a spoon of this kind in common use in Turkey, for the symbols are Christian, and the character of the work is Byzantine; yet Constantinople has been Mahometan for many centuries. This form of spoon must, however, have originated in old Byzantium or some earlier form of worship, and

its significance being lost, the form has yet survived to the present day.

Another instance which will show the survival of an ornament, strangely altered during the lapse of time, occurs in the embattled tops of certain Arabian buildings. The form of these excrescences of the wall would in no way suggest that they owe their origin to flames. Not only, however, can this ornament be traced back to its original shape, but the Moorish name for it signifies fire or flame; had not the name suggested the origin of this embattled form, I should scarcely have been led by its mere shape to trace it to a symbol of fire-worship.

I give these illustrations simply to show that forms which have a special significance to a people who create them may survive in a most unexpected manner, and be even characteristic objects in a country where we should least expect to find them.

We have been speaking of the trident as an instrument of destruction; hence reference should be made to another fact of some interest. In both the Greek and the Latin churches the Saviour, when in the act of blessing, is represented with a hand upraised and the fingers in a particular position; but the two churches arrange the fingers differently. In the old city of Nara, where there were many idols, I observed two with their fingers arranged in the manner of the two Christian churches, and others with their fingers differently disposed. When I asked the meaning of the arrangement of the digits, a priest informed me that if the fist was clenched tightly with the thumb inside, we have an indication of the wrath which will destroy the transgressor utterly. If the fist is closed and the thumb extended, great anger is indicated, but not utter destruction. The priest could not remember the exact significance of each position of the fingers; but he said that they all symbolised different degrees of displeasure. In the case of the clenched fist with the enclosed thumb, reference was made to punishment with the sword; so here we have an idea similar to that presented in the Book of Genesis by the flaming sword guarding the gate of Eden.

The question of the origin of forms found in Japanese art

is connected with their heraldry. On many of their works, especially upon fabrics and fine pieces of lacquer, we find certain decorative devices which might easily be mistaken for mere ornaments. These are really crests or badges granted to families for heroic deeds or benefits conferred upon the country, as heraldic bearings have been awarded to certain families in England.

I know of no book which contains a greater number of beautiful ornaments than the little volume which constitutes the illustrated peerage of Japan; for the crests, although simple in character, are beautifully designed, and many of them furnish us with a variety of simple devices derived from an elementary form which we should scarcely think capable of such various treatments.

Fig. 116 *a* to *j* give some of the crests which have been derived from the leaf of the Maidenhair-tree, yet these are by no means all that owe their origin to this foliaceous form; but besides these we give a few with the view of pointing out their significance. Fig. 116 *t* is a crest representing the wood-work which stands upon the earth around the orifice of a Japanese well; Fig. 116 *s* is derived from five anchors; Fig. 116 *u* is two boat sails; Fig. 116 *k* is the Gohei or Shinto emblem; Fig. 116 *l* is a form of gong; Fig. 52 consists of four knives, such as were thrown by female warriors at their enemies in ancient times; Fig. 116 *o* represents three hawk's feathers. Hawking, as we have seen, was a favourite pastime in Japan (having been introduced by a Corean Ambassador in the early part of the third century), as also was fishing by cormorants; Fig. 116 *n* gives five repetitions of the hammer of Daikoku—the god of riches; Fig. 116 *r* gives the back view of three sitting hares reduced to a most simple form with their heads and ears showing over their backs; Fig. 116 *q* gives us three of those little folded papers which we always find attached to anything intended as a present in Japan—the Nosu; Fig. 116 *p* is a cart wheel; and Fig. 116 *m* represents the heads of three arrows used for the cutting of ropes in ancient warfare;<sup>1</sup>

<sup>1</sup> A curtain or Baku supported on cords surrounded the headquarters of a commanding general during battle. These arrows were especially intended to cut these cords and expose the commander.

but besides these we have crests in the form of mile-stones, mallets, fir-branches, pine-cones, ships, tops, fans of all kinds,—including that which the umpire at a wrestling match holds in his hand,—birds, flowers, drums, roots, helmets, shells, hats, umbrellas, the rudders of vessels, butterflies, horns, water, clouds, centipedes, and a hundred other things. The well-known Shôgun's crest (the crest of the Tokugawa family) consists of three leaves of the Awoi (a species of mallow) arranged in a circle. Crests are not only derived from a multiplicity of objects, but many of them are merely variations of one object. Thus in Fig. 116 *a* to *j* we get ten crests from the leaf of the Maidenhair-tree, as we have just said; and the number might be largely increased.

Nothing astonished me more during my stay in Japan than to find that many of the old works had a strong Egyptian feeling. So striking were these Egyptian characteristics, that I was in some cases almost tempted to think that the specimens before me were works by old Egyptian artists.

On certain Buddhist altars we find a branch of the lotus, ending in a flower and a leaf; while attached to the stem are scales, a young leaf, and a bud (Fig. 19). Such an object is said to have been held out by Buddha, when he prayed for his mother. I need scarcely point out the strange likeness which this object bears to ancient Egyptian work. There is that rigidity about its parts, that simplicity, yet dignity, in its treatment, and that stern conventionality in the drawing of the flower, which would almost lead us to believe that it was produced under the Pharaohs. In the two forms of monstrance which we have figured on pages 155 and 156 we have also conventional representations of the lotus, equally rigid in their treatment, while many of the Buddhas of Japan rest on a flower treated in the same conventional manner. In their temples they use as ornaments on the altars groups of five lily-buds bound together (Fig. 161), which are not less Egyptian in character. It must, however, be noticed that the lily associated with Buddhism is not that of Egypt, the latter being a *Nymphæa*, the former a *Nelumbium*; but each country has simply used the flower growing in the land. In both cases the particular lily

which was familiar to the people was treated with the same rigid conventionalism. In some Japanese forms of the lotus we have two longitudinal convex ridges on the

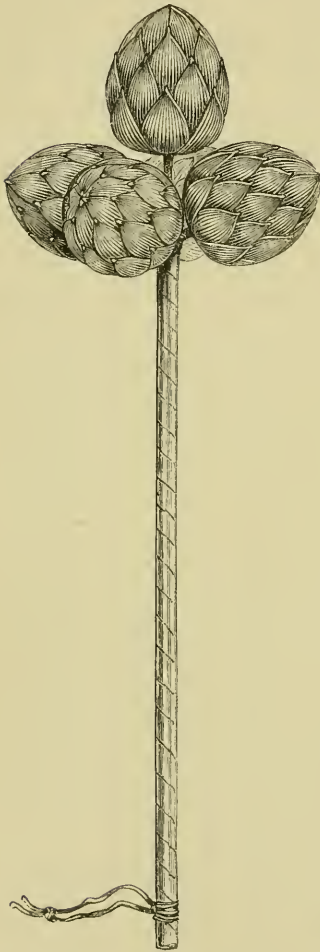

FIG. 161.—GROUP OF LOTUS BUDS USED ON BUDDHIST ALTARS.

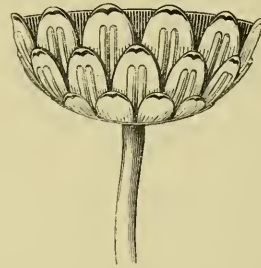

FIG. 162.—LOTUS IN CAST BRONZE, PRESERVED IN THE MIKADO'S TREASURY AT NARA.

petals, such as we find on Egyptian and Greek leaf-mouldings (Fig. 162).

While speaking of the lotus we may also notice that a conventional ornament, having to the scroll-work of China a relation similar to that which "the Anthemion" of the Greeks bore to the ornament of that country, owes its origin to this flower (see Fig. 163); but the work of tracing all the modifications, intervening between the natural representation and the conventional Anthemion, must be left to the student who may wish to go farther into the subject.

Again, we have as the insignia of Japan a golden ball on a red ground, or a red ball on a white ground,—in other words, a representation of the sun. By the ancient Egyptians a similar device was used; and on Plate V. of Owen Jones' *Grammar of Ornament* we have examples of Egyptian work in which this red ball occurs. Thus, it rests on a lotus in the bow of a boat, it

surmounts a stern-post, it occurs on a feather used on ceremonial occasions, and it crowns the head of the asp; while in that ornament which was placed over every doorway and window-opening in Egypt we have the sun as the central figure, and



FIG. 163.—CHINESE ANTHEMION. This ornament was derived from the flower of the Buddhist Lotus (*Nelumbium*), and the leafage surrounding it from Clouds.

wings and asps placed laterally. On an old lantern, pendent in the Tofuku-ji near Kioto, for permission to photograph which I am much indebted to the priests connected with the temple, I found as a cresting a series of balls, or suns, resting on cloud (Fig. 149); and while the Egyptians never used the cloud as ornament so far as I know, the manner in which the ball is here poised on the rounded masses of vapour cannot fail to remind us of the way in which the ancient Egyptians both drew and used their ornaments. I also found a similar ornament crowning the entrances to tombs in China (Fig. 152).

Further, we find in old Japanese works water rendered as the "wave-scroll," and drawn precisely as it was by the Egyptians; we see the key-pattern in many varieties, but especially in the



more simple ways in which it is found in old Egyptian work. We also have birds as a favourite ceiling ornament in both countries, while in each instance a rigid conventionality characterises the drawing; and in some of the renderings of birds there is a striking similarity between the works of the two countries. There is also the simple, yet dignified, portrayal of the figure, as in the Buddhas of Japan, and the sculptured gods and kings of the Egyptians. There is the use of lotus-leaves on mouldings, and we have the slanting walls of the buildings (see Figs. 70 and 45). While, again, the Nile god was supposed to dwell in the lotus-flower, Buddha sits on that blossom as a throne. Besides all this we find that the priestesses at Nara, while performing their sacred dance, used the sistrum or rattle in the manner of the priestesses of Isis, and in both countries the sistrum (like the yoni of the Hindus) symbolises the celestial virgin.

Then the Japanese pillows bear a close resemblance to those of ancient Egypt; the use of the metallic mirror is common to both nations, and in each the circular form has prevailed. The Egyptians had the ibis; the Japanese have the stork; and in both countries the bird is sacred. A lion at Thebes is drawn with a circular ornament on the shoulder, similar to that which we find on many of the old mythical animals of Japan. Patterns formed of birds' heads arranged in linear series are not uncommon in either country. In both we find a sort of capital on granite columns, formed by painted ornament. Many of the little boxes such as were made by the Egyptians for toilet purposes bear a resemblance to little cases which in Japan are adjuncts to the writing-desk. And in both cases the lid swings on a pivot. A common form of spoon in Japan has a shell-shaped bowl with a stick-like handle, while in Egypt we find a similar bowl with a man's arm as the handle. Both countries have used the "yoke" for carrying burdens, and in each case it was similar in form; both have used the palanquin for the carrying of august personages; both have had the folding camp-stool; and in each country large gates were set in pivoted sockets of similar character. Thus the hinging of doors was managed in the same way in both coun-

tries, and the people of both nations are characterised by that peculiar obliquity of the eye which we regard as characteristic of the Japanese and Chinese races. Both peoples also believed in astrology (the Japanese will never go to war unless the stars which constitute the tail of Ursa major point down upon the enemy), and both acknowledge the mystic character of the numbers three and seven.

Then, again, the Japanese employ that system of carving in which the "ground" around the bas-relief is left standing, so that the surface of the sculptured figure does not protrude beyond the surface in which it is cut; yet, so far as I know, this system of producing what I may call sunk *basso-relievo* works has not been practised by any other peoples than the Egyptians and the Japanese. But while the carvings of the temples in Egypt are of this character the examples in Japan are found only on small objects.

It should also be noticed that the religion of ancient Egypt bears some analogy to the Shinto worship of Japan. Thus, in both countries we find the sun as an object of worship, and in both the Phallic idea is apparent. In Egypt also the sovereign bore much the same relation to the church that the Mikado does to Shinto. Thus we find a group of two figures on one of the ancient Egyptian monuments (the one being that of the god Amun-Ra, and the other the Emperor Amunmai-Anemneb), while on the throne of these deified beings is written the King's name and titles: "The Priest, the Lord of the World, the Son of the Sun, Lord of Battles, Amunmai-Anemneb beloved by Amun-Ra, the Giver of Life." In both nations there were many gods.

Nor is this all. There is one coincidence on which I lay more stress than on any other. Certain drawings of papyri found, if I remember rightly, on the temple of Philæ, have little drops pending from the upper portions of the inflorescence; and on Plate V. of *The Grammar of Ornament*, Fig. 9, we find the same peculiarity, while it occurs also on the capital of a column marked Fig. 7 of Plate VI. of the same work. The nature of these drops has never been satisfactorily explained.

In a little work entitled *The Egyptian Court*, described by

Owen Jones and Samuel Sharpe, and published by the Crystal Palace Company, we find amidst other sketches an illustration of a column (*Fig. 50*) and a wall decoration (*Fig. 52*) with this peculiarity, and the remarks :—" *Fig. 50* is yet more complicated : it is formed of several rows of flowers, all full-blown, each flower smaller as it approaches the bottom of the capital. The drops hanging from the edge of the flowers are not easily explained." . . . "*Fig. 52* is a part of another view of a papyrus-field, in which all the flowers are full-blown and have drops from the edges" (*Fig. 164*).

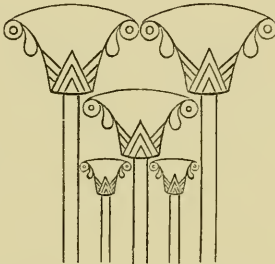

FIG. 164.—EGYPTIAN DRAWING OF PART OF A PAPYRUS-FIELD.

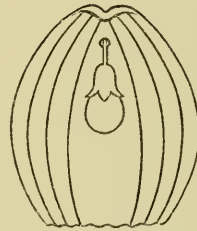

FIG. 165.—PETAL OF A LOTUS FLOWER ON WHICH BUDDHA SITS, WITH A JEWEL PENDENT FROM NEAR ITS APEX. This Lotus is preserved in one of the ancient temples of Nara, and this jewel hangs from each of the outer petals of the flower.

While visiting the old temples of Nara I observed several Buddhas sitting on lotus-flowers, from every petal of which hung pendent a little jewel, or drop ; and in the collection of antiquities preserved there I found a lotus of great age with green petals having recurved apices, while from the tip of every petal hung a little crystal drop set in a brass socket (*Fig. 165*). There can be no doubt that whether these jewels are intended to represent dewdrops, or to typify the water from which the flower rises, whether they are offerings of jewels to the lily, or whether they have a significance of which we now know nothing, they are the same thing represented by the Egyptian artists ; and it is strangely interesting that Japan should open to us a means of understanding the nature of forms drawn by the Egyptians some thousands of

years since. From some lotus petals I also observed a curious ornament depend (see Fig. 166).

The facts already stated may suffice to show that the Japanese have, at an early period, had intercourse with Egypt; but there is something in the "feeling" with which certain works have been executed that cannot be described, and which yet proves more certainly than any mere similarity of form the origin from which the inspiration of the work has been derived. But how this intercourse between countries so remote came about I cannot say. In the early centuries of the Christian era constant intercourse was kept up between China and Japan; and many Buddhist priests from Siam and India also visited the latter country. From the eighth to the twelfth century this intercourse was frequent; nor must we forget that Cambyses, the son of the great Cyrus, made Egypt a Persian province in the year 523 B.C. Whether communication with Egypt was conducted through continental Asia or not I cannot say; but it is probable that this was the case.

There is a form of cross to which reference ought to be made, as it occurs frequently in Japan. By some it is termed the Buddhist cross; but the Germans know it as the *crux gammata*; we, however, have christened it the *fylfot* or *swastika*. In the *Ceramic Arts in Remote Ages* Waring traces this form in various countries, and gives illustrations from Asia Minor; from a coin of Syracuse; from the dress of a figure in the catacombs at Rome; from an old Greek urn; and as found in India, Denmark, North Germany, and on old works from the American continent.

Dr. Inman regards this as an archaic symbol derived from an early form of worship,<sup>1</sup> and Waring regards the Greek key-pattern as derived from this cross. Inman tells us, further, that a

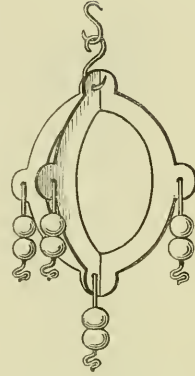

FIG. 166.—ORNAMENT PENDENT FROM EACH PETAL OF A LOTUS FLOWER IN AN OLD TEMPLE AT NARA.

<sup>1</sup> Ancient, Pagan, and Modern Christian Symbols exposed and explained by Thomas Inman, M.D.

particular kind of key-pattern symbolised the tortoise both in Assyria and Greece.

As the history of this form has been so carefully traced, I need only call attention to the prevalence of the swastika in Japan, where it occurs on many objects connected with Buddhist worship and as the crest of a noble family.



FIG. 167.—SWORD-HANDLE OF OLD JAPANESE WORK. The ornament is Damascened work, and is of Celtic character.

I may add that I found on an old sword-handle of native work a pattern formed by the inlaying of silver in a dark alloy, seemingly of Celtic origin (Fig. 167). Many of the grand large-headed nails which are found on the old temples of Japan are identical with those of Moorish manufacture still to be seen in Spain, and a form of pendent lamp, with two or three trays superposed one above the other, and used by the Jews in Morocco, is also a form much employed in the Buddhist temples of Japan.

In this chapter I have brought forward a few facts with the simple purpose of showing the probable origin of some of the features which characterise early Japanese art, and of pointing out to the student that research into the affinities and migrations of races may be aided by a consideration of ornament not less than by the study of a language.

## CHAPTER III.

## THE LACQUER MANUFACTURES.

THE art of working with lacquer is of great antiquity in Japan, and, like most processes practised in the country, was probably introduced from Corea or China; but the Japanese attribute the invention of most of their manufacturing processes to the former. The assertion that "while the Japanese have invented nothing, they have improved upon everything that has come before their notice" is fully borne out by the lacquer-work of the country. The Chinese certainly make lacquered wares, but in Japan the art has been brought to a degree of perfection unknown elsewhere; indeed, some of their low-relief work is modelled with a tenderness and delicacy quite equal to that of the best work of the great medalist, Wyon.

It is a pity that we know so little of Corea, for the Japanese assert that the Chinese as well as themselves learned many of their industries from the Coreans. I confess that my knowledge of the Coreans and their industries is very small, and what little I know has been gathered from the collection of objects which I saw in the Mikado's palace at Kioto, where there was a room full of treasures brought by Japan's great warrior who re-conquered Corea at the end of the sixteenth century—from certain articles offered for sale by the best curio dealers of Kioto and Tokio, and from some few pieces of pottery which have found their way into Europe from this strange country.

As far as I have seen, most of the objects brought from Corea appear to be Chinese works which have been imported to that country, although this idea is quite inconsistent with the Japanese belief that the Chinese have derived many of their methods of work and certain styles of ornament from the people of this peninsula. However this may be, the inaccessibility of Corea prevents our tracing back the manufactures of Japan to this country; and we want a Commodore Perry to open to us Corea as he did Japan.<sup>1</sup> This, however, is certain, that at one time Japan enjoyed considerable intercourse with Corea, and that a large commerce was carried on between the two countries. Indeed, Japan received either from or through Corea the civilisation which it has enjoyed for some hundreds of years; but I have never seen even one piece of lacquer which could be regarded with certainty as of Corean origin.

In the Mikado's collection of antiquities at Nara there are certain pieces of lacquer-work which are known to be more than a thousand years old, and in the palace in Kioto are many ancient works of this character with known dates; but until about six hundred years back the art could only be regarded as having been in a crude state. At this period able artists were employed to paint the patterns upon lacquered objects, and low-toned colours were somewhat freely used upon such productions.

The actual workmanship was at this time less meritorious than it became at a later date; but there was an art quality about the work which has scarcely been equalled since. About three hundred years back the lacquer-workers themselves undertook the decoration of the objects formed, and then the highest manipulative excellence was attained—an excellence which characterised the best lacquer wares down to about one hundred years back.

During this period of two centuries little colour was employed in the lacquer-work, but much gold was used; and those particular kinds of work in which "clouded" gold effects, *avanturines*, and *tesselated gold* are introduced, as well as low-relief modelling of a

<sup>1</sup> While this work has been in the press Corea has been opened to us.

most perfect kind, were invented and brought to a high state of perfection.

While the best work, as regards the skilful treatment of lacquer as a material, was made during the seventeenth and eighteenth centuries, it must not be supposed that a sudden decline in the lacquer-worker's art took place at about the year 1800. Men have since lived who must be regarded as great masters of their art; and I believe that works are now produced equal to the finest productions of the two great centuries of lacquer-working, although there was a decline in the art for a few years.

In the last Paris International Exhibition a large folding screen was exhibited by a Yokohama dealer named Chogoro, which was in every sense a work of the greatest excellence. Besides the bold, magnificently-treated, foliage, which was of the most tenderly-worked lacquer, lotus flowers were formed of pearl and wisteria flowers of small polished mussel shells, which in conjunction with the lacquer-work vastly heightened its effect. This work was one of the most marvellous that lacquer-workers have ever made; and while it sold for some hundreds of pounds, it was, as a work of art, a thing to be loved and treasured quite as much as a painting by a master-hand.

I cannot help thinking that we in England over-estimate the decorative value of pictures. Many who cover their walls with costly paintings have scarcely an object in their houses besides these which has any art merit. The vases on the chimney-piece, the *epergne* on the table, the nick-nacks in the cabinets, and the service for the afternoon tea-drinking, are all alike incongruous and meretricious. Surely persons whose houses are thus furnished have but little real love of the beautiful; he who admires what is pleasant in form and lovely in colour would regard the beauty of each object around him and the *tout ensemble*.

Choice objects in lacquer are about the most *recherché* of drawing-room ornaments, and in art merit exceed almost any of the *bric-à-brac* now collected. Indeed, some specimens are so perfectly worked, so rich in decoration, so minute in detail, and so tender in execution as to be fit for a place in any boudoir in



the land ; and the soft smoothness of their surface is almost more perfect than that of the most fragile porcelain.

But the choice works of which I speak were not made with any view to their money value. Like most of the beautiful objects which Japan formerly produced they were created for the use of some Daimiô or as presents for his friends.

In the great Yashiki (spread-out house) of the Daimiô were lodged, beside the owner and his family, a number of retainers and handicraftsmen, who were fed and clothed by the prince whom they served. The handicraftsman thus provided for had no cares or anxieties, and sought no money in return for his work. His wants were fully met by the provisions made for him in his master's abode. It was his care and aim to please his master, and he well knew that by the production of excellent work the end of his ambition would be gained. No thought of haste entered into his mind ; no hurrying to make a showy day's work was thought of : his only desire was that of producing the best work that man can achieve. Works thus made have an inexpressible charm.

A few years since, lacquer objects of the highest excellence could be purchased at a trifling cost ; but now these old works are so much sought after by the Japanese themselves, as well as by those of advanced taste in England, France, and America, that they are becoming both rare and costly. Indeed, so valuable has old lacquer now become in Japan, that pieces have been bought in London, and returned to the country in which they were made in order to be sold again.

In Yokohama, for a box about six inches square, and dating from the end of the seventeenth century, I was asked a sum equal to one hundred pounds in English money, and Lady Parkes told me that a friend of hers had given for a fine specimen its weight in gold. The Japanese appreciate not only those elaborately-decorated wares, but also certain objects which exhibit a peculiar quality of lacquer ; of this they judge chiefly by its hardness. On the wonderful mountain Koya-zan the priest of the temple in which we stayed presented me with a little tray of old red lacquer. To me this was a somewhat imperfect work ; its surface

was not very smooth ; the grain of the wood and brush marks were visible on its surface, while in parts the red was rubbed off, and black showed through. Upon seeing this tray, Mr. Ishida, who was an excellent judge of lacquer, tapped it with the points of his finger nails, and then spoke of the excellence of the lacquer. Upon my asking what constituted its merit, he told me that it was its hardness. He also said that while common lacquer would easily scratch, that of superior quality could be indented only with difficulty.

Soon after this Mr. Ishida's statement was verified in a manner for which I was scarcely prepared. After purchasing, amongst other things, a lacquer "spill" of great beauty, and made eighty years since by a most excellent man, whose ancestors for eight generations had made similar work, I told a packer to treat this rare object with great care. Fancy my state of mind when I saw my beautiful "spill" filled with old nails and bits of rough iron ! I stormed and blustered ; emptied the vessel of its contents, wiped it tenderly, felt for it as I should for a dog whose tail had been crushed, and ordered the packer to wrap it in many thicknesses of soft paper, and give it a box all to itself.

In an hour after this I returned to see how the packing was proceeding, and how my injunctions had been obeyed. To my surprise and disgust I saw my favourite pot again filled with nails and scrap-iron. My wrath knew no bounds ; and with more of the British lion in my voice and gestures than I am in the habit of displaying, I hurled at the poor packer an amount of abuse which I should not like to see in print. When my wrath was somewhat exhausted, the poor man, whom I had so lavishly censured, said calmly, "You would not have me put them into the commoner articles, for if I did they would be scratched ; but this is the best lacquer and cannot scratch." I am bound to say that he was right, and that I cannot now find any mark on my lovely spill which tells of the rough usage to which it was subjected.

As I write I have before me two or three pieces of lacquer, the ages of which are accurately known ; so with the view of

enabling my readers to judge, as far as possible, of the age of such works, I will describe them somewhat minutely. Here is a box made about five hundred years since, and therefore before the period at which the lacquer-worker became his own decorator. It bears a pattern drawn entirely with a "touchy" or "broken" gold outline, and consisting of circular ornaments (one of which is a conventionally-treated bird with a cloven tongue of fire upon its head), clouds, leaves with five leaflets, conventional pomegranates, and coral-like scroll ornaments, some of which are filled with small diaper patterns. The ground is black, and the enrichments are "filled in" with dull red, raw sienna, and dark olive-green colours; but the outline has been drawn first, and the filling-in colours do not quite meet it.

Here is a tray belonging to the same period, and decorated with the same class of ornament; but the work in this instance is somewhat inferior, and is evidently that of a different hand. But while this tray is square with corners cut off, the painted ornament only occupies a central circle, while the marginal portion is covered by figures in low-relief. This modelled work gives to the outer portion, both in texture and character, much the appearance of stamped leather. Works of the period now being considered are imperfect; but there is a merit in both design and execution which the artist cannot fail to perceive.

Now we will notice a writing-box, which dates from the end of the sixteenth century. It is nine inches and a quarter in length, eight inches and a half in width, and two inches in depth, with an overhanging lid. It is of black lacquer, with a few cloud-like ornaments on its side, while the bevelled edges of the lid scintillate with pearl dust. On the top of the lid is a device representing six strips of paper, strung on two threads knotted together; but both the front and the back strip are represented as obliquely folded in the centre. Each strip is one and a half inch in width, by about seven in length; but while they represent paper, they are yet formed of metal. The first has a silver surface, decorated with clouds, while its back (as seen where it is turned over) is of gold. On this gold surface clouds are also drawn. The second and the

third strips are each of pearl—the one being decorated with representations of water, and crests having the form of a cart-wheel, while the other is figured with broken diaper patterns. On the inside of the lid we have a similar bunch of papers, only here one is of aventurine lacquer, while on two gold strips the figure consists of flowers formed of pearl.

It is curious that while we have here the elements of gaudiness, this work presents a refinement of effect, as well as a finish, which few Europeans' works possess. If we use gold freely we generally get a meretricious effect ; and by the inlaying of pearl we almost invariably secure vulgarity ; but with the Japanese the lustrous surface of mother-o'-pearl is so skilfully used as to produce repose, rather than garishness, in the object which it decorates.

The last work is a beautifully-finished box, such as Japanese of high rank support their heads on during sleep, as we do on a pillow. This object is exquisitely made, and is covered with a small diaper pattern in gold on a black ground. Here and there are dispersed over the diaper-work heraldic devices, which constitute the Shôgun's arms. In some cases the crest is wholly of gold, while in others it is in part silver, for colour plays no part in Japanese heraldry. These crests, and certain portions of the diaper, have a raised gold outline ; while the finish of the whole is extremely perfect. This box is about one hundred years old, and is a fair specimen of the late work of the eighteenth century.

On some of the examples from this particular period, and also from a somewhat earlier date, we find sprays of flowers in low relief modelled with the tenderness of the image on a shilling ; but I must not attempt to describe such works, for no description will convey an accurate idea of modelled ornament.

A kind of lacquer formerly made in Japan (at Wajima in the province of Noto) under the powerful prince of Kaga, is much valued. It is generally black in colour ; but its peculiarity lies in the fact that it is ornamented by scratched, or scraffito, work, into which gold is rubbed. I have here before me two old boxes made under this Daimiô, and decorated in this manner. They

are very beautiful, and are figured with a most careful drawing of a graceful grass called *susuki*, a plant much admired by the educated Japanese, and one of the seven celebrated autumn flowers of the country.

Of this particular lacquer ware there are but few specimens in the country. Indeed, I am not sure of having seen any specimens besides the two which I myself possess. Inferior imitations of this ware are, however, still made in Japan, both with and without gold in the scratched work, one of the seats of this modern manufacture being Kuroye-Mura, near Wakayama; but the ware here made is altogether inartistic. Some similar ware is also made at Osaka.

There was another kind of lacquer made by a man called Ritsuo, whose work became most celebrated, and who lived about two hundred years ago. This man made lacquer boxes with raised ornaments, the whole being black and bearing a striking resemblance to objects carved in jet. This ware was an imitation of old Chinese lac-work. Before me is a specimen of the Chinese work made in the year 1573, A.D.

Ritsuo also placed raised figures on fan-holders, and made shell-like vessels, to which he gave an appearance of iron. He also incrustated cups and vases with lacquer, and gave to these also an iron-like surface. I am not aware that "iron lacquer" was produced at a period earlier than this, but whether Ritsuo was the inventor of this particular ware or not I cannot say.

Some works of this great manufacturer have come into this country. But the majority of the pieces which reach England are made by Ikede Zeshin, a man who still lives, and who has not only adopted the style of his predecessor, but makes deceptive imitations of the older work; even the cracks and chips of the old specimens being counterfeited.

Another ware, much prized in Japan, is characterised by heavy pieces of lead so inlaid that they protrude from the surface of the lacquer. Generally such works have a certain amount of gold decoration as well as this raised lead-work, while in a few pieces some portions of the lead are covered with a thick layer of

burnished gold. To the English eye this lead-work appears crude; but the Japanese admire the contrast of the common metal with the beautiful surface with which it is usually associated.

When Mr. Kawase, the Japanese Minister of Commerce, visited England a short time since, he sent me a magnificent specimen of this particular work, with the following kind letter :—

“The accompanying trifle, which I have brought with me, is simply a mark of respect to you, whose intelligent suggestions have done so much to promote the arts and manufactures of Japan.”

Another kind of lacquer which has great excellence and marked characteristics may be described as more or less resembling the carved red lac boxes, which are amongst the most interesting of Chinese manufactures; but this Japanese ware is not carved after the lacquer has been applied to it. Yet many existing specimens made by a great master of the art who lived in Tokio are very charming, for while the ground of his works is either covered with a minute geometrical diaper or a morocco-leather texture, the little clouds, conventional birds, scroll-work, and medallions placed upon it are generally wrought with great care and feeling, some of the medallions being exquisitely rendered and with parts almost as sharp as the cut lac of China.

In all specimens of this ware that I have seen the ground work is slightly “dead,” and has the appearance of being carefully dusted with Vandyke-brown powder, while all the raised parts, however fine, are black and polished. This ware to some extent resembles that by the celebrated Ritsuo; but the work of which we now speak has a diapered or “tooled” ground with the sunk surfaces of powdery character, whereas that of Ritsuo which bears raised ornaments, so far as I know, always has a smooth ground, and much more nearly resembles simple jet-work than any other form of lacquer ware.

How this old ware was made I am not certain, but the present manufacture, as carried on in Tokio, consists in carving wood with great accuracy, and then giving to this wood (however minute the pattern cut upon it) one or more coatings of lacquer.

I have also found inferior work of this description made by cutting devices in a thick, leather-like paper, and sticking these on to wood, and by affixing impressed ornaments to the surfaces of boxes and trays, and then giving to them a coat of lacquer. But such works have little or no art value, and are comparatively without interest.

There are in Japan many kinds of lacquer-work besides those already mentioned, and many men have lived who have produced characteristic kinds of work. It is impossible for me to enumerate all of these, for there is scarcely a celebrated maker whose works have not been imitated by others; and the untrained eye cannot distinguish these imitations from the original works: certainly without the opportunity of comparing originals with imitations, no one can learn to separate one from the other.

There is much lacquer-work of varying merit made throughout the whole of Japan. A man named Shunsai, of Kioto, is now celebrated for the manufacture of black lacquer sachi kettles and such things as are used for the "tea ceremony" (Cha-no-yu). A black lacquer-ware with bold vermilion ornaments is also made in Kioto, while a kind of work in which consecutive layers of different-coloured lacquers are superposed one on the other, while the whole is incised with convoluted but deeply-cut V-sinkings by which the various-coloured layers are exposed, is made at Osaka.

Interesting boxes, formed of wood covered with fine basket-work (like that which encloses many of the eggshell sachi cups) and decorated with good raised lacquer-work, are sometimes made in Suruga; but the fine specimens appear to owe their origin to the Loochoo Islands. It is surprising what beautiful drawing and careful modelling is produced by the agency of lacquer on rough grounds. I have seen specimens of this ware with ornaments wrought upon them but little inferior to any work that I have ever met with.

Little trays, formed of a wood dug from bogs and closely resembling the bog-yew of Ireland, are everywhere to be seen. These have little flowers in gold lacquer upon them. All such

works are, I believe, comparatively modern. The earlier specimens have merit, but those which are now found in the English market are common and uninteresting.

While works in lacquer were produced in many parts of Japan, the finest were made in Kioto ; but excellent specimens were also produced in Tokio. Since the removal of the Court from Kioto the manufacture of artistic works in this beautiful material has been chiefly centred in the present capital.

In speaking of Japanese lacquer-work we must not overlook the fact that lacquer is applied to many purposes of which we in this country know absolutely nothing. Thus the floors of the great temples are covered with lacquer, and have a surface as bright as that of any tea-tray ; and while these great temples are as highly coloured as the Alhambra at Grenada, their polychromatic effects are due to the admixture of lacquer with pigments.

Some of the lacquered panels in the temples are of vast size, and the carvings which are so frequently seen on the temple enclosures are large and bold ; yet every portion is lacquered with the utmost care. These large masses of lacquer-work are quite unknown to us in England.

As regards the places in which lacquer wares are made, we have already said that the best are produced in Tokio and Kioto, but the districts of Aidzu and Yechizen are almost given up to this manufacture, while in the province of Dewa yellow lacquer goods are made.

The manufacture of lacquer wares is carried on in ordinary houses, and not in any special building or manufactory. The lacquer-workers kneel upon matted floors, just as though they were resting in the living apartment and were not engaged in any special industry ; while, if the work is good, the room in which it is made is exquisitely clean and perfectly free from dust.

Lacquer is almost invariably placed upon wood, and not upon paper, as is often supposed. Indeed, lacquered papier-maché work is but little known in Japan, and is made in but one small district. Trays thus made are usually decorated with figures, and are invariably common in quality. I know of but one consignment of such



goods having reached England ; and out of some scores despatched from Japan, I believe only three or four reached this country whole, the material of which they are formed being of a brittle character. There are a few very small and delicate "waiters," of but a few inches in diameter, made in Tokio of sheets of paper pasted together ; but broadly speaking, all good Japanese lacquer-work has a wood foundation.

If we take the formation of a cup or bowl, however thin it may be, it is first rudely formed from a piece of perfectly dry, soft

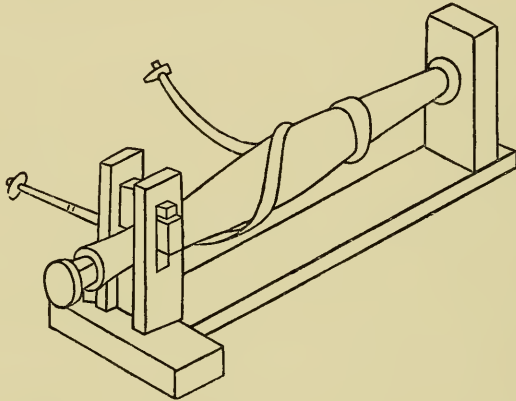

FIG. 168.—LATHE.

wood. It is then placed in the lathe and turned ; but the lathe has not a continuous rotary motion, as its spindle revolves first in one direction and then in the other, in the manner of our "bow-drill" (Fig. 168).

When the object has been formed in the lathe, the lacquer-worker carefully examines it ; and, by the aid of his lacquer, which he now uses as a glue, sticks over each faulty or weak place, should there be any, a piece of thin fibrous paper, or entirely covers the object with this material. The next process consists in giving the vessel a coat of raw lacquer, but into this first coating clay-dust or some earthy powder is generally introduced with the view of giving it hardness. Another coat is now added ; but between the several coats the article is carefully "rubbed

down" with a "cutting" stone. The surface of lacquer goods is worked up in much the same manner as our carriage bodies, clay-dust or stone powder being used with the lacquer whenever the surface is to be much ground down. If the object is to be of excellent quality, it will have received eleven coats of lacquer before any decoration is placed upon it. But the coats are not all the same; for after two or three layers of lacquer containing earthy matter have been applied, other coatings are given with an inferior quality of lacquer, in which colour may or may not be present, but which has none of the earthy matter used in the earlier coats.

After the application of the latter coatings the surface is ground with hard charcoal. This charcoal is used in lumps which are constantly dipped in water; and, after several coats of lacquer have been applied, and rubbed down, the final surface is produced (if it is to be a fine work) by three or four layers of the best lacquer each being carefully ground to a smooth surface. For producing the final surface lumps of soft charcoal are used, which, like the hard, are kept wet. The work is now polished with ash of deer's horns.

The pattern which is to be formed upon the object is drawn upon a sheet of fibrous, and somewhat elastic, paper; and the drawing is made in fine outline with lacquer used as a paint. This drawing is now transferred to the object to be decorated by bringing the surface of the drawing in contact with it. When the paper is so arranged that it fits to the curved surface, simple pressure of the hand suffices to make the transfer. The paper is now gently separated from the bowl, or whatever is about to be decorated. But to insure that the lacquer thus leaves the paper it must have been previously warmed.

This process of transferring closely resembles the method by which we "print" patterns upon earthenware; and all designers of patterns for our manufactures know some method of getting designs from one paper to another. Thus far there is no novelty to us in the process.

The transfer being made, if the pattern is to have a gold

outline, the transfer line is followed by a fine hair pencil containing lacquer, which acts as a gold-size. When this lacquer line has become sufficiently dry, fine gold dust is shaken on it from a spoon. Some of this powder adheres to the tacky surface, but what is not thus fixed is returned to a saucer in which the gold is kept. This gold powder has a gray hue, but by burnishing it assumes the yellow colour.

It will be noticed that on most fine pieces of lacquer-work there is gold of two or three kinds. Sometimes we have masses of great solidity and brilliancy, while more frequently we see little tesserae glinting from gold of a less brilliant character.

The less brilliant gold always results from the adhesion of gold powder to the surface of half-dry lacquer; but the tesserae, and the solid masses of which we have spoken, are produced by the use of gold leaf of the thickness of writing paper.

Upon my asking a workman to show me how this tessellated work is produced, he took a small sheet of gold about an inch in

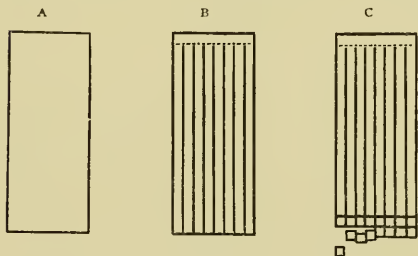

FIG. 169.

length and a third of an inch in width (Fig. 169, A.) This he placed horizontally upon a curved piece of bamboo, which had been previously blacked (Fig. 170, A). He bound it in its position by placing over it a piece of semi-transparent paper which he tied to

the curved bamboo with a string (Fig. 170, B). With a curious knife (Fig. 170, C, shows part of its blade) having the shape of a chisel, and with the sides sharpened as well as the end, he cut the little leaf of gold into strips; but as the extreme end of the leaf was folded over the edge of the bamboo, these strips were still attached at one end (Fig. 169, B). In order to cut the sheet of gold the paper was also cut through. This little sheet of gold, being now cut in strips, is liberated from the bamboo to which it was strapped. It is now held on the curved piece of bamboo by the thumb and finger in any convenient position, and strips are cut

across by the same knife (Fig. 169, C). As each row of tesserae is thus formed, the little bits of metal are carefully shaken into a black saucer. These tesserae are now applied to the lacquer surface in the following manner.

A few are shaken into a small black tray with a slightly raised rim, over which they are spread as much as possible (Fig. 170, D). With a small pointed stick, held in the right hand, the tesserae are picked, one at a time (Fig. 170, E), from the tray (which is held in the left hand by a little strap like our gilder's cushion), and are applied to an adhesive lacquer surface. It will generally be found that these little squares of bright gold are dispersed in a surface formed of gold powder; but in some cases flowers are formed of exceedingly minute portions of this thick gold leaf, and in some cases silver is used in a similar manner.

I have here before me, as I write, a little medicine case which is decorated with certain sprays of the Susuki grass and certain umbelliferous plants; but its peculiarity consists in the fact that each head of blossoms (of which there are many) consists of hundreds of these little gold tesserae. So close are the tesserae together that at first sight each umbel of the umbelliferous plant might seem to consist of but one piece of slightly rough gold.

On this little medicine case, which is three and a quarter inches in length, two and a quarter inches in width, and seven eighths of an inch in thickness in its widest part, there are fifty-nine heads of flowers, each being half an inch in length and

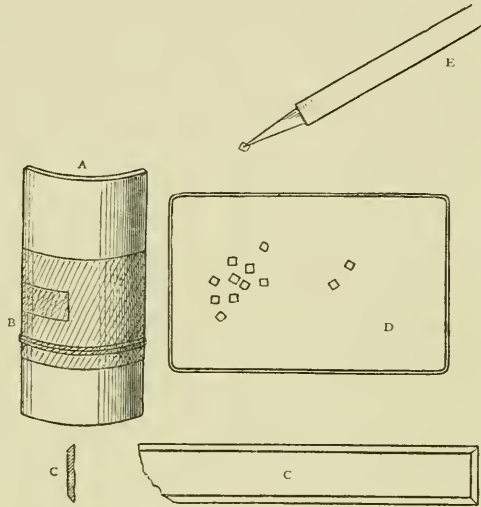

FIG. 170.

three-sixteenths of an inch in width. On each eighth of an inch of these flower-heads, there are about one hundred and twenty distinct pieces of gold ; thus, taking each head as having a superficial area of five square eighths of an inch (not five-eighths of an inch square), there are about six hundred tesseræ in each of these heads, or over thirty-five thousand on the box.

But this is not all ; the little heads of Susuki grass are tipped with these little cubes : hence the number of these small tesseræ (which have been applied one by one to the medicine case) must be very large. For this interesting little work I am indebted to Mr. Wakai, a gentleman whose acquaintance I made in Japan, and have had the opportunity of renewing in this country, which he visited some little time back.

When watching the process of lacquer manufacture in Japan, I observed an old man producing cloud-like effects on a cabinet that promised to be of great beauty when finished. By his side was a sheet of paper about eighteen inches square, on which were a number of small saucers—perhaps twelve or more. In each of these saucers was a gold or pearl powder. There was gold of

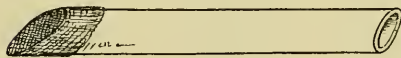

FIG. 171

different colours and different degrees of fineness. Across each saucer rested a reed, having an internal diameter of about three-sixteenths of an inch. Each of these reeds was cut diagonally at the bottom, and over the diagonal orifice was glued a small piece of fabric. To me this appeared to be silk (Fig. 171).

This fabric acted as a sieve, and in the tubes were gold dust, pearl powder, or colour. As the fabric was finer or coarser, so the powder that came through it was fine or coarse. Some of the fabrics were so fine that only atoms, which when alone were imperceptible, came through them.

If any part of an object was to be clouded, a reed was taken with a fabric, both thick and fine, fastened over its end. This was held in the hand of the workman much as we hold a pen. A vibrating motion was now given to it by a tapping with the

fourth finger ; thus the finest of dust fell on the sticky lacquer and formed the edge of the cloud. Now a slightly coarser powder was used from another reed ; then perhaps a sprinkle of colour, —the colour being used if a tint were required with the gold.

Over the gold, however applied, one coating, at least, of lacquer is spread, unless the work is of the very commonest sort. The latter coatings fill the interstices between the particles of gold or pearl, or whatever has been used in the formation of the pattern. After the application of the last coating of lacquer the object was passed to a woman, who rubbed it down with a small piece of charcoal, kept flat by frequent grinding on a stone.

This charcoal is made from various woods, and is of varying degrees of hardness—a rough kind being used for the first coat, and a finer for each consecutive surface. So carefully is this rubbing down effected, when the work is of the finest quality, that such lacquer as fills the interstices between the particles of the gold only remain—all else being most carefully removed. This being done, the surface received one or two thin coats of lacquer, each of which was ground down by charcoal, when a final polish was given by the ash of deer's horn applied by soft leather.

Raised work results from the use of lacquer mixed with red oxide of iron. If the "relief" is to be great, this mixture is at first crudely applied by the agency of a spatula and brush. By repeated painting the relief figure is brought gradually to assume something of the form desired. Delicacies of form are now produced by the most skilful grinding with small strips of charcoal. All good relief-work results from processes of painting and grinding, and not from anything analogous to carving ; by such means the most delicate and tender of modelled ornament is produced.

When this work has been brought to the form required, the parts may be coloured or covered with gold ; or they may be first covered with some coloured pigment, and then have gold or silver dusted upon them. In the latter case the colour will show through the powder and have a tinted lustrous effect.

Lacquer is dried by being placed in a cool cupboard, which

has been washed with water immediately before the lacquer has been placed in it. While some say that lacquer will not dry unless in a damp atmosphere, I feel sure that moisture is employed simply to prevent its cracking, which, I believe, it will do if it be placed in a dry air. The cupboard used for this drying process in one of the chief factories in Tokio was in the corner of the workroom, and was about five feet broad, three feet high, and eighteen inches deep; it had shelves formed of square wooden laths, and the interior of its ceiling or top was brushed over with water every morning. The lacquer takes from eight to eleven hours to dry in this chamber.

In the case of common lacquer-work the surface is polished with deer's-horn charcoal and soft leather, and then the drawing is made in lacquer to which gold is applied, but no protecting coat is added.

The inlaying of pearl in lacquer is effected almost exactly as we inlay it in our papier-maché work, the process differing only in details. The pieces of pearl from which the parts to be inlaid are cut are very thin, and can be used as tracing-paper. Before a work, which is to contain inlaid pearl, is begun, a drawing of the pattern is made on a sheet of paper; this drawing is transferred to the box or tray upon which the pattern is to be wrought. Little sheets of pearl are now placed over those parts of the pattern which are to appear in this lustrous material; the forms covered by the sheet of pearl are traced upon it; then the little sheets are removed.

With a curious chisel-like knife the pearl is cut into the necessary shapes, and is stuck by lacquer in its respective positions. After all the pearl is in its place, the whole surface is covered with repeated coats of lacquer, by which the pearl is entirely hidden. By grinding a smooth surface is secured, and the pearl again appears, but is now level with the general surface of the object. The pattern is again transferred to the surface, having been fitted to the bits of pearl, so that they may take their right places; and the decoration in gold or colour proceeds as already described.

Lacquer is a substance which in appearance much resembles treacle or dissolved shellac, and like these substances it is sometimes pale and sometimes dark in colour. In many respects lacquer is allied to gutta-percha and similar substances. It is unhurt by hot water or ordinary acids. It resists the action of vinegar and boiling ascetic acid; and caustic potash does not hurt it. Hence it cannot be injured by any ingredients used in cookery.

When in a fluid state it is highly corrosive; and if one drop comes in contact with the skin it generally eats its way through to the bone and produces a serious wound. Even from visiting a lacquer factory some persons take a kind of fever.

There are many details respecting the lacquer manufactures which it is impossible here to notice; and celebrated men have little secrets of their own which they will not readily divulge. For the production of coloured surfaces certain pigments are mixed with the lacquer, while very frequently a vegetable colouring-matter is used to make a desired tint. But the character of the work and the degree of its excellence is due largely to the nature of the lacquer used, and to the manner in which it is treated.

Raw lacquer is a tenacious fluid of a gray-brown colour which "skins" over like our oil paint upon exposure to the air. When collected from the tree it is allowed to stand and settle. The better quality now rises and the impurities sink, so nothing more than decanting is needed to separate the good from the inferior. But straining through cotton or a porous paper is resorted to as a means of refining the lacquer.

Superior lacquer is stirred in the open air, by which process it becomes more or less oxydised, at the same time it loses its excess of water and assumes a brilliant dark colour.

Usually lacquer is brought to a surface by processes of grinding and final polishing, as we have already seen; but by the use of a kind of "dryers" called ye-no-abura (an oil derived from a labiate plant called *Perilla ocimoides*) it is changed into a varnish which acquires brilliancy by mere hardening.



Used thus, its colour is a lustrous, transparent, and warm yellow ; but by the use of gamboge, the sap of unripe persimmons, or other vegetable stains, the richness of its hue is increased. Richness of effect in a finished work is also secured by staining the object to be varnished, instead of by modifying the character of the varnish itself.

Black lacquer (called roiro-urushi) is produced by stirring crude lacquer in the open air for two or three days, and by adding to it a little water impregnated with iron, or with iron and tannic acid. In this way the richest black is produced ; and the addition of the water is absolutely necessary for the attainment of great brilliancy.

Just as some of our artists when painting a black dress "ground" their work with red, so as to give richness to the black, some Japanese lacquer-workers introduce into black certain stains with the view of giving "quality" to the colour. If the lacquer is too thick for use it is thinned by rubbing into it a small amount of camphor.

For all purposes in which the adhesion of gold, silver, or colour is desired, lacquer, converted into a varnish by the addition of oil, is used.

Plasticity, by which it is rendered susceptible to stamped impressions, is given to lacquer by the addition of powdered beans or albumen from eggs; and many effects produced by lacquer are due to the quality which it thus acquires. By a process of stamping and filling of the depressions all kinds of marble effects are produced. A form of marbled lacquer called tsugaru-nuri is made in this way, but the stamped surface is covered with tin-foil before the later coats of lacquer are applied. Specimens of this work are not common in England, although they are so in Japan. There is another variety of lacquer called wakasa-nuri produced in a similar manner.

Akita lacquer is made by varnishing with lacquer, to which a volatile oil has been added, wood or flattened bamboo, previously coated with size to which a little alum has been added. The best is produced on junks lying out at sea, so as to avoid dust.

Inferior works are formed in various ways: by sizing the object to be lacquered two or three coatings of lacquer may be saved; but by this treatment the durability of the work is sacrificed. Common raised work is also produced cheaply by a paste formed of rice-flour; but as this is not even impervious to water, objects so decorated are almost useless. In every country we have the genuine article and its imitations. If decorative works are to be produced at a cheap rate with the apparent qualities of superior work, artifices must be employed in their production which can only be condemned.

The tree (the *Rhus vernicifera*) from which lacquer is obtained abounds both in Japan and China, but the lacquer produced in Japan is better than that grown on the Asiatic continent. Curiously, the lacquer-tree not only produces lacquer, which flows from its lactiferous vessels, but also wax, which is extracted from its seeds.

There are male and female in the lacquer-trees, and the female only produces seeds. Lacquer-trees sometimes grow to the height of thirty-five or forty feet, but lacquer is obtained when the trees are from five to eight years old. This being the case it is rare to see a large lacquer-tree in Japan, save in those instances where it is kept for seed-growing, and, consequently, wax-producing, in which case it is allowed to reach a good old age.

The lacquer-tree is generally raised from seed, but some reproduce it from sections of the root. The raising from seed is considered the better plan.

If it is raised from the root the reproduction is managed in this way:—The root of a tree which has been cut down is divided into pieces, which are set as we set potatoes. In time these “sets” send out a shoot and give rise to a new plant. As many of these sets fail to produce a plant, the method of reproducing by seeds is preferred.

This is one of the few instances known in which a true root will send out adventitious branches. As a rule no plant has a power of producing either buds or branches below its “collar” or “medial line;” but one or two plants are known to botanists

which have this strange quality, and of these the lacquer-tree is one.

The quality of the lacquer depends largely on the nature of the soil in which the tree is grown. If the ground is good the tree will acquire a circumference of about seven inches in four or five years.

To obtain the lacquer the outer part of the bark is sliced off the tree-trunk, and then an incision is made into the stem by a kind of knife. The juice now oozes out of the puncture, and is scraped from the stem by a flat iron tool. This operation is very slow, for a tree is cut only once in the day, and is then not cut again for four days; but the same tree is cut many times, and the first puncture is made near the base of the stem, while each successive cut is farther from the root.

When the stem has been punctured from its base to its apex the tree is cut down; but from the branches of the felled tree lacquer is also obtained. To this end they are cut into lengths of about two feet six inches, tied into bundles about eighteen inches in diameter, and soaked in water for from ten to twenty days. These are now cut all the way up, when the lacquer oozes out and is collected by scraping.

The season for obtaining the lacquer begins in summer and ends in October. The lacquer obtained at the beginning of the season and at the end is not very good, the best being produced in the middle period. The first quality is called *hen*, and the second *uragaki*. The third and fourth are of but little value.

In those districts in which wax is gathered from the lacquer-tree they formerly never extracted the lacquer from the female plant, for by so doing they were afraid of retarding the growth of the tree. In recent years they have, however, taken to doing so; but they do not cut the trees grown for their wax as much as the male trees which are reserved exclusively for lacquer, and the incisions in the stem are only made at distances of six or seven inches, and not almost close together as in the male trees.

There is a plant called the mountain lacquer-tree which grows wild, and has flowers and leaves closely resembling those of the

cultivated variety ; but as it produces very little lacquer it is of little value as a lacquer-tree, though its seeds yield a considerable quantity of wax. There is also a third plant from which lacquer is derived, called the vine lacquer, which is a creeper ; but this yields even less than the mountain lacquer-plant. The cultivated lacquer is grown chiefly in the eastern part of Japan—in the provinces of Yechizen, Yamato, Yoshino, Iwashiro, Aizi, Uzen, Yonezawa, Mogami, Yamagata, Nambo, and Fukuzu. The first named provinces have produced lacquer from remote times, and the produce of these provinces is very celebrated ; but the very best quality is produced in Yoshino.

Lacquer varies in price according to its age and nature, but as a rule three hundred and fifty me (one hundred and twenty me make a pound) cost a dollar (about four shillings and two pence) where it is grown. Eight thousand me make a barrel. The wood of the lacquer-tree is very hard, and is of fine grain ; it is used for many purposes, and especially for buoys to mark where the nets used in the sardine fisheries have been sunk. The small branches are used for fences and for fuel.

## CHAPTER IV.

## THE POTTERY MANUFACTURES.

WHEN I started for Japan I thought my knowledge of Japanese potteries and pots tolerably perfect ; but when I returned from that country, after visiting nearly seventy potteries, I came to the conclusion that even then my knowledge of Japanese ceramics was most limited.

During my stay in the country the unfortunate rebellion already mentioned broke out, which prevented my visiting some of the leading pottery districts ; hence on some of the manufactures I can give only hearsay information. Yet I have no doubt as to the trustworthiness of what I was told, inasmuch as my informants were well acquainted with the matter of which they spoke ; but in this chapter I shall be careful to specify the cases in which I speak from personal observation, and those in which I am retailing what I have learnt from others.

There is a complication about Japanese potters and potteries which it is very difficult to unravel, for nice distinctions are in some cases made which are more than confusing to us. As an instance of what I mean, it may be noticed that Banko ware was invented by a man whose name it bears, but that this particular form of pottery ceased after a time to be made. After the lapse of some years this ware was re-invented, or revived, by one Mori Yogozayemon, a man who, though old, still lives ; but it is his son that now carries on the pottery, and this son I have seen. His works are at Obuke-mura, in the province of Isé.

Besides the son, many others learned the art of potting in the Banko method, and these are mostly settled in the town of Yokkaichi, which may be regarded as the special seat of the Banko manufactures. In the town of Kuwana, which is situated at no great distance from Yokkaichi, inferior wares (such as we should regard as Banko) are also made, and throughout Japan these are regarded as Banko wares, yet at Kuwana they are regarded as imitation Banko, while all through the country similar wares made at Tokio and Kioto find little favour, being considered spurious and not original works.

Some time ago men who had learned the art of potting in Yokkaichi removed to the province of Minō, and there founded a pottery called Onko; but the ware here made is thicker than most Banko ware, and is chocolate in colour; while that of Banko is generally of a soft, warm gray. Yet some specimens of Banko ware are of a red-brown hue. Onko ware is classed as altogether separate from that of Banko. But the Yokkaichi potters now also make imitation Onko wares, and thus the confusion becomes great.

Another difficulty in the way of our understanding Japanese wares results from a practice which is common throughout the country, namely, that of bequeathing to a son, or a favourite apprentice, the trade-mark of a celebrated ware. A man becomes famous as a potter, and his mark, or trade name, becomes known (the name used in trade is very seldom the real name of the potter). Now it often happens that a celebrated potter has a son and two or three apprentices. In such cases he will leave his name and mark to the most skilled among them. It frequently happens that an apprentice inherits the name of the famous potter, and even should he move to another place, he will be considered the maker of the genuine ware, while the son, who carries on the manufacture at the original works, will be regarded as the mere imitator of his father's productions. In support of these statements I could adduce many illustrations, but I need not do so, as some of the difficulties of understanding the various questions connected with certain kinds of Japanese pottery will

appear as we discuss the wares. I mention them here in order that the reader may at the outset understand the nature of the case, and may see how impossible it is for any one who has not visited Japan to write a history of Japanese pottery which shall be really trustworthy. Another difficulty occurs when a celebrated potter removes from one part of the country to another,—a case which is not uncommon.

In the town of Okazaki I visited a potter who made remarkable wares, and who bore a good name as a manufacturer. But he formerly carried on his art at Kioto, and he removed to this place so as not to interfere with his son, to whom he had bequeathed his business. This man, Yeiraku Zengoro, left his "mark," as well as his business, to his son, and he now trades under a new name, and since I left Japan I have heard that he has again returned to Kioto.

Here we have a case in which a celebrated man makes wares precisely of the same character as those which he formerly produced, and in the same town, yet the "mark" which he now employs would indicate that his present productions are the works of a different potter.

In treating of the ceramic manufactures it is difficult to know what sort of classification to pursue, for if we speak of the manufactures of a district we shall thereby separate similar wares. This classification would also lead to confusion, as in some cases the various manufactures bear the name of the town or district in which they are produced. Yet if we take similar wares we shall have to travel almost from one end of Japan to the other to collect our specimens. On the whole, it may be best to arrange certain kinds of wares together, for we shall thus have the advantage of contrasting similar specimens which have been produced at different parts of the country.

While pottery of a rude kind was made at an early period, it was not until Korean artisans were brought to the country that any important advance in the manufacture was made. At the beginning of the sixteenth century a Korean potter named Ameya came to Kioto, where he made a common black earthenware

with lead glaze. This is especially valued for use at the "tea ceremony" (*cha-no-yu*); and for eleven generations the descendants of this man have made the same wares. So esteemed was the ceremony by Shôgun Taikosama that he honoured this particular manufacture with a golden seal, on which the character "raku" (meaning enjoyment) was engraved.

With the view of giving some idea of the esteem in which the vessels used at the *cha-no-yu* were formerly held (the ceremony was most fashionable about four hundred years since), we may mention the fact that the competition for objects specially valued (as some of these black raku cups) was such that wars were often waged between Daimios with the sole view of possessing certain coveted goods, and with the envious object of despoiling another of his possessions of this sort. Instances are recorded of Daimios burning down their houses rather than let the spoiler rob him of his wares. One noted warrior gave his tea-treasures away, thus at the same time saving them from destruction and defeating the purpose of the raid upon him.

But it was between the years 1580 and 1590 A.D. that one, Gorodayu Shonsui, a native of Isé, who had been to China to study the porcelain manufactures, returned and settled in the province of Hizen. Here, with the material found in the country, he succeeded in making various kinds of porcelain.

About this time certain Corean porcelain makers were also brought to Hizen, together with certain spoils of war, and they rendered important aid in the new manufacture.

At about the same date the Prince of Satsuma, who had invaded Corea, brought home with him a certain number of porcelain makers, with their families, and placed them near Kagoshima, the capital of the province, where after many trials they succeeded in making the now famous Satsuma ware.

With these two important manufactures at the end of the sixteenth century, the art of potting in Japan may be said to have fairly begun; for although rude earthenware has been made from time immemorial, and tiles for the roof of an imperial temple were produced about 660 A.D., and although the potter's



wheel was introduced in the year 724 of our era, and a Chinaman made stone-ware at Setto in the thirteenth century, yet no works of importance were produced till towards the year 1700.

It may be well to begin our notice of the potter's wares by considering faience, stone-ware, and the different kinds of earthen-ware which have become well known. The Japanese mind delights in novelty and humour. For his own amusement the potter will often make a few pieces of a ware different from those generally known ; but with the few specimens produced we have the beginning and the end of the ware.

Banko is the name of a man who lived at Yokkaichi, in the province of Isé, and who made an unglazed stone-ware of a purple-brown, and of a light-yellowish colour. He used a clay of such toughness that he could form small objects, as teapots, of extreme thinness ; but the great peculiarity of his ware consisted in his ignoring the use of the wheel and the lathe, and forming his vessels by pinching the clay into shape between the finger and the thumb.

With the death of Banko the production of this ware appears to have ceased, and it was Mori Yogozayemon of Obuke-mura who re-discovered the art. This man, as we have just said, still lives, and his son, who has succeeded to his business, works at Obuke-mura to this day. But it is at Yokkaichi that the best Banko ware is now made. Here a number of men who learned the art from Mori Yogozayemon, and from one another, now pursue this manufacture ; but the same class of ware is also made at Kuwana, Kioto, Tokio, and other places.

At Yokkaichi the chief potters are Nakayama Magohichi, Iriyama Kainosuke, Shitomi Shiohei, Yamanaka Chiwzayemon, Hori Tomonao. All these men are engaged upon the manufacture of similar wares ; only the productions of some are better than those of others. But the prince of the potters is Yamanaka Chiwzayemon, who makes kettles of extraordinary thinness. A kettle by this man, measuring four and a quarter inches in diameter, and two and a half inches in depth, made of unglazed

gray stone-ware, is so thin that it can be seen through, and it weighs just over two ounces and a half with its lid. It has been made simply by clay being pressed by the thumb and finger. A teapot, somewhat smaller, with the usual form of handle, and a beast nearly an inch in length for a knob on the lid, weighs but an ounce and three quarters. These are triumphs in Banko work, and only the one manufacturer can form wares of such delicacy.

The first kettle which I have mentioned has a knob formed of a double volute of clay, and it is decorated on one side and on the lid with storks in flight, and on the other side with storks reposing on a river's bank. Of the storks in flight there are no less than fifty-seven on this little work, while there are forty-three at rest; and each one is painted in enamel white with its feathers outlined, a black tail, a little brown shading, a touch of red on the head, and in most cases a line of green on the bill (Fig. 59, page 175).

While the better pieces of Banko ware are all made with the thumb and finger, the commoner goods are shaped on a wooden mould; and, in the case of teapots, nearly all have a knob so attached to the lid that it will rotate, or a ring pendent from the handle, which will swing. Many have the handle perforated as a fine geometrical pattern.

Of Banko wares, it may be remarked that the particular forms of handle, which are undoubtedly Japanese, are that which arches the orifice of the vessel, as the handle of our pails, and that which corresponds with the handle on our saucepan. Although the looped handle, similar to that on our teapots, is no longer uncommon, and although I see before me, as I write, five specimens with this form of handle, there is every reason to believe that it was derived from European examples brought into the country by the Dutch. Yet on a Chinese jug, which was, undoubtedly, made four hundred and fifty years since, I see this form of handle, and on several ewers preserved at Nara are examples of a similar character. This form of handle, then, may have been derived from Continental Asia and not from Europe.

Some specimens of common Banko ware are formed of a red earth, from which large panels have been cut, and the opening thus formed replaced by a semi-transparent white clay. In a teapot of brick colour, and with a "stippled" surface, having the texture of "morocco leather," are two panels of white earth, the one having the form of a fan, and the other a cardeoid or blunt heart ; but this ware is modern.

Another recent form of Banko has a marbled surface resulting from the combination of imperfectly mixed clays ; but the effect thus produced is coarse, and the ware has no art value.

Banko wares are often decorated ; but while a few pieces by the best makers are tenderly painted, the decoration is generally both crude in colour and coarse in character. This is to be regretted, as the ware itself is excellent. If accompanied by good painting it would be much sought after by lovers of beautiful objects.

Modern Banko wares are sometimes glazed, in other cases entirely covered by an opaque colour (generally a full green or an unwelcome pink), and in some cases vessels are glazed internally only. The glazed ware, as well as the unglazed, may be decorated.

We not unfrequently see, in our large grocers' shops, little rough teapots offered for sale for a few pence. These are imitation Banko wares made at Kioto and Tokio by potting cottagers, who perform their work in a most simple manner. Small though these teapots be, they are such as the Japanese have in common use, for while they frequently drink tea they indulge themselves with a mere sip at a time. A large vessel or a large sip are alike vulgar.

Onko is the name of a chocolate-coloured ware of no great thickness, which is solid and well made. It was invented by a small group of men who left Yokkaichi and removed to the province of Mino where they founded a pottery called Onko, from which the ware derives its name. But this ware is now imitated in the town from which the men departed.

Another ware of unglazed red earth is shaped on the wheel, and is made at Tokonabe in Owari or Bishiw. This is called Tokonabe ware ; but although the things produced are specimens of careful potting it enjoys no great celebrity.

A kind of stone-ware, valued in Japan on account of its hardness, and which is sometimes glazed and sometimes unglazed, is known as Bizen. In appearance it much resembles that common form of stone-ware of which we make ginger-beer bottles ; but it is also made of a dark-red colour. In some cases a decorative effect is produced by a bamboo or some other spray being incised in the clay. This ware is said to be the hardest produced in Japan. It is exposed to the action of fire, in the process of manufacture, from fifteen to thirty days. It is made in Imbe and other places in the province of Bizen, and its name is that of the district. Besides jars, bottles, pots, and other vessels, we often see figures made of Bizen ware ; and some of these are of considerable age. Bizen ranks amongst the oldest of existing Japanese potteries.

Another celebrated ware appears to be made with the finger and thumb like that of Banko, generally in the form of small jars or cups. It is covered with a gray-brown glaze, and is invariably decorated with a horse or with horses—this is Soma ware. The horse is the crest of the Prince of Soma, and is the only instance, I believe, of a Japanese crest being an animal.

Besides these wares, which are all celebrated, and to which we should perhaps add the old Kioto wares, there are others of less importance as Hikone, the old wares of Kenzan, of Kinkozan, Rokubei, the wares of Tokonabe, Takatori, Sado, Toyosuke, and others ; but to iterate all the wares of this class that are known, even tolerably well, in Japan, would be to make this part of my book a mere catalogue of wares, which in the absence of coloured illustrations could only be useless. But I may just mention that Mashimidsu Zōroku of Kioto—a potter who enjoys considerable notoriety—makes stone ware vases which have incised lines, filled with white slip, covering their surface. The grounds of these vary from a pleasant gray to a rich brown,

and the white is not obtrusive. The whole is glazed and has a pleasant, though rough, effect. I may also mention that Kiyomitsu Rokubei, also of Kyoto, makes an exceedingly crude ware which he covers with an opaque white glaze, on which he gets rich granite-like effects of colour—greens, reds, and black being mingled together; that Sawamura Tōsa of the same city makes a crude heavy ware, which is in part covered with a transparent, treacle-like glaze, and in part with a glaze thick with white opaque matter, as well as curious rough yellow leaves of the Buddhist lotus. These latter he often shapes into quaint forms and decorates with well-modelled crabs. Miyai Sajōrō of Ota-Mura, near Wakayama, also makes a kind of pottery, which, from its resemblance to the creature, is called sea-slug ware.

Besides these there is a whole series of rough crackle wares which are all somewhat imperfectly baked. The best of these is made by Oki Toyosuke of Nagoya, and is generally known as Toyosuke or Toyoske ware. This is a form of pottery made of a buff-coloured earth covered with a semi-opaque crackle glaze which has a white or sea-green cast. Sometimes below the glaze there is a rude sketch of a figure or a pine branch in a sort of "Payne's-gray" colour; and from the top of the object a rich juicy green often flows over the paler glaze. In this ware the crackles are distinctly marked in a sort of soft neutral tint.

Another ware of a similar description is made by Inui Chio, a widow potter of Osaka; but her wares are characterised by having a bird, a bat, a crescent moon, or some such device cut into the surface, or by having raised figures of flowers, dragon, or mountain, upon them, while nearly all the pieces have flowers drawn upon them in a sort of inky colour.

The most important ware which we have to notice as a Japanese faience is that which is now so well known under the name "Satsuma ware." But whether it should be classed as a faience is doubtful, for while but to a small extent vitreous in its body, it appears to have the composition of a porcelain.

As we have already seen, Shimadzu Yoshihisa, Prince of Satsuma, brought with him when he returned from the conquest of Corea a number of potters, to whom he assigned the task of producing a new and acceptable ware from the materials found in their new home, and the result of their efforts was the production of the ware which took the name of the province, and which has acquired well-deserved celebrity.

This pottery was established shortly before the close of the sixteenth century, and its wares are made of a porcelain clay which differs from the true porcelain mixture, as it does not undergo to any considerable extent fusion by firing. Its glaze is formed chiefly of felspar and woodash, freed from its alkali. It has neither borax nor lead in its composition, and the body and the glaze are simultaneously fired at a much higher temperature than is commonly used for the formation of biscuit ware. When burnt, Satsuma ware is of pale vellum-like colour, and its surface presents a fine network of cracks. We have classed it with the different kinds of faience, but it is in character almost a semi-porcelain.

Old Satsuma ware was generally made in small pieces, such as bowls, saucers, and teapots, and was decorated with birds and flowers and conventional ornaments, the latter frequently forming bands around the objects. The chrysanthemum, the pæony, the domestic fowl, the pheasant, and the peacock were commonly used. It is also distinguished by the tenderness of its outline, the beauty of its reds and greens, and by the solidity of its dull gold pencilling.

Old Satsuma ware has now become rare in Japan, and during the whole of my travels in the country I never saw but three pieces, while six or seven pounds was the price asked for a small teapot.

Large pieces of this ware appear never to have been produced until comparatively recent times, and it must be remembered that the Japanese have but little use for large vases in their own houses. Those huge specimens which are occasionally shown to us as examples of old Satsuma ware must be regarded as the

products of some other pottery; but of such works we shall shortly have to treat.

I think it well here to reproduce an article by Mr. E. Satow of the Tokio Legation on "The Korean Potters in Satsuma," as he visited the district and I did not. He says—

"There appears to be good ground for believing that Korea once enjoyed a much higher degree of material civilisation than, as we learn from recent sources of information, it enjoys now, and, when we consider the extent of the ruin wrought in that peninsula by the Japanese armies in the end of the sixteenth century, and the general difficulty experienced in countries where the civilisation is Chinese of recovering from such disasters, we shall not be surprised to find the modern Koreans far behind their neighbours in the practice of the useful arts, though in former ages it was to them that the Japanese went for instruction. One of the arts brought to Japan from Korea was that of pottery, and those who have seen specimens of the delicate, white, translucent Korean ware, to which an antiquity of about five centuries is assigned, will readily admit that the Korean potters possessed in those days a degree of skill which was worth imitating, and secrets which were worth the sacrifice of much money and pains to obtain. The Japanese, always ready to learn from others, have, from a period which may be called prehistoric, at various times invited Korean artisans to settle in their country, and several schools of pottery are said to have been founded by these emigrants. As the learned antiquary, Ninagawa Noritane, tells us in Part V. of his invaluable work on the history of Japanese faience, the common sort of pottery called raku-yaki was first made by Koreans whom Hideyoshi caused to be brought to Kiyauto. The kilns in which it was baked were built in his palace of Jiuraku, whence the ware took its name. The descendants of others who were settled first at Agano in Buzen, and later at Yatsushiro in Higo, after the withdrawal of the Japanese troops from Korea in 1598, still carry on the production of Agano ware. Another Korean was the first maker of Nakanokura ware, near Hagi in the province of Nagato, and became the founder of a family which still exists there, and in the province of Satsuma there is a village entirely inhabited by potters of Korean origin, whose forefathers were transplanted from their native country about the same time.

"The ancestors of these people were brought over in 1598 by Shimadzu Koshihiro, the feudal lord of Satsuma, and settled at Kagoshima, the capital of the province, and at three villages, named Kushikino, Ichiku, and Sañnogaha, in the department of Heki. Some of them were afterwards removed to Chiyosa in Ohosumi, on the Kagoshima Gulf, where they continued to exercise their art, and their descendants live there to this day. The larger number were collected together in the end of the year 1603 at Nahashirogaha or Tsuboya, a village on the high road from Ichiku to Kagoshima, about twelve miles from

the latter town. They belonged to seventeen families, named Shiñ, Ri, Boku, Heñ, Kiyau, Tei, Jiñ, Riñ, Haku, Sai, Chiñ, Ro, Kiñ, Ga, Tei, Shiya, and Sai, and their descendants still keep these surnames, which are pronounced as above according to the Japanese fashion. The personal names in use among them are usually composed of two Chinese syllables, according to the Korean practice, but the women bear Japanese names, such as Fude (Pen), Yuki (Snow), and the like. The whole population of the village numbers about fifteen hundred. The wares made by the first generation of captives were chiefly of a coarse kind of dark pottery with a black glaze, and this manufacture is still carried on at Tsuboya, the principal articles produced being teapots, pipkins, and large jars for packing the dried tea-leaf. Between the years 1624 and 1644 a skilful workman named Boku Teiyau made the discovery of white sand at Kaseda, and of white clay at Ibusuki, and from this period dates the manufacture of the white Satsuma cracked ware (called hibiki-de) so much esteemed by European connoisseurs. But for a long time the ware appears to have been ornamented very sparingly with colour, and the oldest specimens are altogether devoid of it. About the close of the eighteenth century a Korean named Kiñ Zenkai, and Kuhabara Jiuzawemon, an inhabitant of Kajiki, made a journey to Kiyanto, where they learned the art of decorating earthenware with figures, landscapes, and set patterns in the style of colouring called Nishiki-de. This is the sort by which the Satsuma ware has acquired its great reputation. Most of the fine pieces in this style were produced at some potteries established by the Prince of Satsuma at a place called Tatsuno, whence they were removed six or seven years ago to Tanoura, a village on the bay about a mile to the east of Kagoshima. The ware was manufactured regardless of expense for the prince's own use, or for presents to the Shiyaugun and to his fellow-daimiyau, to which circumstances is owing the great perfection to which it was brought. Connoisseurs distinguish it by the richness of the gilding, the delicacy of the drawing, and subdued harmonious colouring. During the last few years the painted crackle has been made by private individuals, or by companies trading with funds advanced by the local administration with a view to profit, and it would perhaps not be too much to say that nothing worthy of the collector's attention has been produced since 1868, the year of the revolution.

“ In February of last year I had an opportunity of visiting the Korean village of Tsuboya, where I was most hospitably lodged and entertained by one of the inhabitants, to whose care I had been specially commended by a Japanese friend. There is nothing distinctive in the appearance of the people or in the architecture of their houses ; they all speak Japanese as their native tongue, and wear the Japanese dress ; Tsuboya is in fact just like any other village. The principal potteries belonging to the Koreans are situated on the side of a hill to the south of the highroad, together with the kilns belonging to the Tamano-yama Kuwaishiya, a company recently started by some Kagoshima *Samurahi*. The Tsuboya crackle is produced at this establishment and at another on the opposite side of the road, owned by a Korean named Chiñ



Jinkuwan, but most of the villagers devote themselves to the manufacture of common brown earthenware.

“The principle of the division of labour seems to be thoroughly-well understood and applied by these workmen. One will confine himself, for instance, to the bodies of teapots, of which he can produce about a hundred and fifty in a day, another makes the lids, a third the spouts, a fourth the “ears” or projecting pieces into which the handle is inserted, while to a fifth is assigned the joining of these parts together. Generally the members of a family work in concert, and form a sort of co-operative society, which is joint owner of a kiln with other such societies. The clay used for the coarse ware is found at Isakuda and Kañnogaha, near Ichiku, and at Terawaki, Kukino, and Noda, near Ijifu-iñ, all in the neighbourhood of Tsuboya. Chocolate-coloured, red, and green glazes are obtained from Tomura, Kañmuri-ga-take, and Sasa-no-dañ, while Ishiki furnishes the glaze for water-jars and other large articles of the coarser kind of ware. Three sizes of wheels are in use, the smallest of which is formed of two wooden disks about three inches thick, the upper one being fifteen inches, the lower eighteen inches, in diameter, connected by four perpendicular bars somewhat over seven inches long. It is poised on the top of a spindle planted in a hole of sufficient depth, which passes through a hole in the lower disk, and enters a socket in the under side of the upper disk, and the potter sitting on the edge of the hole turns the wheel round with his left foot. The largest wheel is about twice the size every way of the smallest. The kilns are built up the face of a hill in parallel rows. Each is divided into a number of chambers with openings in the intervening partitions to allow of the passage of flame and hot air from the lower end of the kiln right up to the head, and there are apertures in the side of every compartment—a larger one for the ware to be passed in and out by, which is of course closed during the firing, and a smaller one through which the workmen in charge can watch the progress of the baking. The fuel is placed in the lowest chamber, which is about six feet square, and consists of split pine logs about two feet in length and a couple of inches in diameter. Two hundred and fifty or sixty bundles of wood are required for a single firing, which usually lasts about thirty-six hours. No stands are used for the brown earthenware while it is being baked, but the articles are piled on each other, every second one being upside down; they consequently adhere together slightly when brought out of the kiln, but a gentle tap with a piece of wood is enough to separate them. Between the heavier pieces, such as the large jars used for packing tea, small bits of dry clay are inserted to keep them apart. The glaze is put on by immersion; the article, as for instance a teapot, is dipped into the liquid upside down in such a manner that very little gets inside, and then being quickly reversed, is set on its base, so that the glaze flows down pretty equally all round. When dry the glaze is of a yellowish-gray opaque colour, and it is put on before the article is subjected to any process of firing. The material used for the finer kind of earthenware, that

is, *saishiki-de*, or painted ware, and *nishiki-de*, into the decoration of which gold enters as well as colours, consists of white clay from three localities, namely, Mount Kirishima, Ibusuki, and the gold mine at Yamagano ; of white stone from Kaseda and Kushiki ; and of white sand from Kominato. Ibusuki supplies in addition a second kind of clay called *bara*, which is said to be very brittle, and no doubt is the ingredient which gives somewhat of the character of porcelain to certain pieces of the ware. The Kaseda stone is used also for glazing when powdered and mixed with the ashes of *nara* wood (*Quercus glandulifera*), or some other sort of hard timber.

“The clay and stone are well pounded, soaked in water, and passed several times through a fine sieve placed over a receiver. The minute particles which settle at the bottom are then taken up and dried on boards. To this process is given the name of *midzu-boshi*, or water drying, and it is common to all branches of the manufacture. For the fine white earthenware four kinds of clay, together with *bara* and white Kaseda sand, which have been previously subjected to *midzu-boshi*, are mixed in certain proportions known to the experienced workman. Lumps of this stuff are placed upon wooden blocks and pounded with hammers to the extent of about three thousand blows, by which it is brought into the state of raw material, but previously to being actually converted into clay for the potter's use, it requires about three thousand blows more. It is considered to improve in quality the longer it is kept.

“The kilns in which *nishiki-de* and *saishiki-de* are baked are one-celled, and built of clay upon a foundation of brick, with walls about six Japanese inches thick.<sup>1</sup> Fire is kindled in the mouth of a passage which projects from the front of the kiln, and the hot air passes up this to the chamber, where it can circulate freely round the muffle in which the biscuit is deposited. The largest of these kilns have the following dimensions :—

1. Externally—

Height (Japanese measure)	. . . . .	5·5 feet. <sup>2</sup>
Diameter	. . . . .	4·5 ”
Length of hot air passage	. . . . .	5·0 ”

2. Internally—

Height	. . . . .	4·5 ”
Diameter	. . . . .	3·5 ”
Height of hot air passage	. . . . .	1·2 ”
Width	. . . . .	0·9 ”

A space of four inches in width is left between the muffle and the inner wall of the kiln. For *nishiki-de* three firings are necessary : firstly, the *suyaki*, after which the glaze is put on ; secondly, the *honyaki*, after which the piece is painted and gilded ; and thirdly, a slow and gradual firing which develops

<sup>1</sup> There are ten Japanese inches to an English foot.—AUTHOR.

<sup>2</sup> The Japanese foot is the same as our own.—AUTHOR.

the colours, the duration being twenty-four, forty-eight, and ten hours respectively. During the last firing the temperature is observed from time to time through an aperture near the top, the test employed being a piece of pottery marked with various pigments, which gradually assume the desired tints as the heat increases.

“A memorandum drawn up by an official of the Kagoshima prefecture, for presentation to the commission which presided over the Industrial Exhibition, held last autumn in Yedo, gives the composition of the pigments used for producing the various colours of the fine Satsuma wares. Dr. Edward Divers, Professor of Chemistry at the Imperial College of Engineering, has kindly examined specimens of these materials procured in Yedo, and has furnished me with their English names. The mixtures for the various colours are as follows :—

“Red.—Ground white glass, soft or lead variety (*shiratama no ko*), white lead (*tau no tsuchi*), colcothar or red oxide of iron (*beni-gara*<sup>1</sup>), and a silicious earth called *Hino-woka tsuchi*.

“Green.—Ground white glass, white lead, copper oxychloride (*roku-shiyau*), and silicious earth.

“Yellow.—Ground white glass, red lead (*kuwaumeitan*), silicious earth, and metallic antimony (*taushirome*).

“White.—Ground white glass, silicious earth, and white lead.

“Blue.—Ground glass and smalt (a ground blue glass, the colour of which is due to a cobalt compound; the Japanese name is *hana-kongiyau*).

“Purple.—Ground white glass, white lead, and manganese.

“Black.—Ground white glass, white lead, an earthy manganese ore containing a little cobalt (*wensei*), and a very silicious carbonate of copper, apparently ground and elutriated malachite (*shihonuki rokushiyau*).

“At the pottery belonging to Chiñ Jinkuwañ I saw groups being modelled in the white clay, which, after baking and glazing, assumes a light cream colour, and becomes what is known as Satsuma crackle. These articles were intended to be decorated later on with gilding and colours. The potters here possessed only two old pieces of plain ware, a *teuji-buro*, and a figure of a child playing with a diminutive puppy. The *teuji-buro* is an utensil formed of two pieces—namely, a brasier and a boiler on the top of it, and is intended for distilling oil of cloves, though in practice it is used merely as an ornament. Two artists were employed in modelling figures of Kuwañoñ (pr. Kannoñ) and Dharma in white clay, with the conventional face and robes given to Buddhist personages, and toes all of the same length. A third was engaged upon a tiger sitting up in a cat-like posture, intended to be two and a half Japanese feet in height when finished. Most of their figures are modelled from drawings in Indian ink, but the coloured designs are laid on from memory.

---

<sup>1</sup> Dr. Divers informs me that *Beni-gara* is a corruption of Bengal, whence this substance was formerly obtained.

“Until fourteen years ago a ware called *betsu-kafu* (pr. bekkô) *yaki* was made at this village, the colours of which were intended to imitate tortoise-shell. It was a common ware, and used to be exported to Nagasaki in large quantities. A piece of this, said to be old, which was exhibited to me, had green blotches, as well as the two usual colours, yellow and brown. At the Tamanoyama company's establishment all sorts of ware are produced—common brown pottery, inferior blue and white, and highly gaudy crackle. Here I found a workman engaged in modelling a statuette of Christ after a sentimental wood-cut in a religious periodical called the *Christian Observer*. He had copied the face and beard with considerable accuracy, but had draped the body and limbs in the robes of a Buddhist priest. Some stones of brown earthenware, imitated from American iron stones, were ready for the kiln; their price was to be seven dollars, delivered in Yedo. I saw also some huge white vases of monstrous shape composed of hexagons, circles, squares piled up, as it were, pell-mell, the result of an attempt at originality, unhampered by traditional notions of form.

“The account given of themselves by the Kaurai jin (as they are called) is, that all the inhabitants of the village, peasants as well as potters, are descended from Koreans brought over during the period Keichian (1596-1615) by a Satsuma Samurahi named Ijifu-Iñ. Until about three years ago they wore their hair tied up in a knot at the top of the head; but most of them now wear the Japanese queue, or cut their hair in the style which has been introduced from abroad. They informed me that in former days they dressed themselves in their own costume on special occasions, as, for instance, when they went forth to salute the Prince of Satsuma as he passed through their village on his way up to Yedo. One of the potters was good enough to put on this dress in order to give me an idea of its appearance. He began by drawing on a pair of wide trousers of dark blue silk of a very delicate material, differing from the ordinary Japanese hakama in having no division between the legs, but tied on in the same way—that is, the front part was tied on by strings which passed round the waist, and then the back piece was fastened by strings in a double bow-knot in front. Next he threw over his shoulders a wide-sleeved mantle or haori of like colour and texture, the sleeves of which were not sewn up in pockets as those of the clothes worn by adult Japanese usually are, and fastened it with strings on the right side of the waist. Finally, he crowned himself with a long conical black cap edged with white. He also produced a broad brimmed black hat, apparently woven of the stem of a kind of creeper. The knowledge of the Korean language is still kept up by some among them, whose duty it is to interpret between castaway Korean junkmen and the Japanese officials. Before the destruction of the monasteries the inhabitants of the village belonged to the Buddhist sect, Teñdaishiu, which was no doubt that of their ancestors in their native country. At present they are under the protection of a Japanese deity, whose shrine, called Giyoku-sañ-Guu, stands on a hill south-west of the village. In front of the shrine stand

a couple of lanterns of white ware with a blue design, presented by the potters belonging to sixteen out of the seventeen families, as may be seen by the names inscribed on the pedestals. The tombs in the cemetery, which lies at the side of the path to this temple, do not differ in any marked manner from Japanese tombs, which is what we should expect to find, as the style of sepulchral monuments in Japan is essentially Indian-Buddhist, and most likely derived through Korea. It appears that these people marry freely among themselves, identity of surname not being considered an obstacle as it is in China, but seldom intermarry with Japanese except they be members of the Samurahi class. I gathered, in fact, from the conversation of the villagers, that they considered themselves much superior to the aboriginal natives of the country to which their ancestors had been transplanted.”<sup>1</sup>

There is a curious ware called *sameyaki*, which was formerly made in Satsuma, and is little known in England. Its ground is of buff or brown earth, while the glaze has shrunk into convoluted or ruminated heaps, so that between them the ground is “dead.” This is a peculiar ware, and seems to result from a remarkable contraction of the glaze in the process of firing, and from an antipathy of nature between the body of the vessel and the glaze. The aspect of the glaze is much like that of water that has fallen on fine dust and arranged itself into globular or irregular raised masses. Most commonly this ruminated glaze is of a dull white colour, but in some cases the more raised parts have a bright black aspect.

The popularity which Satsuma ware attained led to the establishment, in a suburb of Kioto called Awata, of certain potteries in which it was to be imitated. Here, with the same clay, a class of ware was produced which bears a close resemblance to that copied, only the imitation is of a slightly deeper and somewhat more yellow hue. This ware—which is named after the district in which it is made—was originally decorated in a manner widely different from that of Satsuma, as it had but a few colours, and those neutral, and its sketches were drawn in thin, light lines. But recently it has been figured with patterns somewhat closely resembling those of Satsuma ware. As a rule, how-

<sup>1</sup> In this article many words are spelt in an unusual manner: thus we have Korea for Corea, Kiyauto for Kioto, Buzeñ for Bizen, etc.

ever, the work on the imitation is smaller than that on the wares made under the famous prince of the South.

Awata wares are now made of all kinds and qualities. Some are utterly common, and are only suited to the ignorant caprices of a European public, while others are both tenderly wrought and daintily decorated.

I have said that the ornamentation of Awata wares is generally on a smaller scale than those of Satsuma ; yet this is not always the case, for I have before me a pot decorated with a quince blossom which is bolder than anything I have seen on works from the South ; but this is an exception to the rule. Then, again, although the colours with which Awata pottery is decorated are generally rather strong, yet some pieces are made with the softest of hues ; and while Awata ware has generally the leaves and the flowers with which it is decorated outlined, yet some pieces have drawings upon them of a masterly character which are touched in with spirit and have none of this laboured work.

In the district of Awata there are many potters, some of whom make the particular ware of which we speak, while others do not. But there are scores of men who manufacture Awata ware in some form or other, although the makers of that of superior quality are few. There are also men living outside this suburb who make Awata ware ; for the name has now become applied to a particular production, which simply bears the name of the locality in which it was first produced.

The names of the three chief Awata potters are Kinun Ken, who makes excellent but most expensive wares ; Kinkozan Sobei, who is the largest maker of this ware ; and Tanzan Seikai, who is also a man of considerable importance in the district. But both in the district of Awata and beyond it there are other men in a somewhat large way of business who make this well-known imitation of Satsuma ware.

Here in England we commonly meet with persons who speak of their Satsuma specimens as though this ware were common ; but in ninety-nine cases out of every hundred these turn out to be examples of Awata ware. Even the Satsuma ware now being

produced is about ten times as costly as Awata ware, and yet it is only a keen eye that can distinguish between the two. Little Satsuma ware, either old or modern, reaches England.

After Awata, the island of Awaji began to produce imitation Satsuma wares; and although these attempts belong to a later date than those of Awata, this island has yet given us finer works of the Satsuma type than any which have come to us from Kioto.

Awaji is an island at the northern entrance of the inland sea, lying out in front of Hiogo. Its chief town is Sumoto, but its potteries are in the village of Igano.

These potteries are two in number. The one was founded about fifty years since by Mimpé Kishiu, whose desire was to imitate the Dutch delft. This pottery is now owned by the son of Mimpé, but his trade name is Rikita. The other pottery now in Igano is large and is owned by Sanpé, a nephew of old Mimpé.

It is only Sanpé who makes the imitation Satsuma ware, and his wares bear patterns which are simple in character, precise in their drawing, and full and rich in their colouring; but the quantity of this ware produced is altogether insignificant, and he is happy who possesses a specimen.

Upon asking how long it would take to produce a tea service of this description, good Mr. Sanpé, after much consideration, thought that he might get it done in two years; and, with the exception of a few pieces made for a special order, I don't know of the existence of a dozen specimens in England.

Awata and Awaji produce work which, while bearing a close resemblance to real Satsuma wares, can scarcely be said to be deceptive imitations of the more valuable productions of the South. But this cannot be said of some of the works fabricated at Shiba, in Tokio, and at Ota, near Kanagawa. Here two factories, possessed of the means of producing excellent works, have been established for simulating old works and producing deceptive copies of the most valuable pieces of Satsuma ware.

So far has this unworthy manufacture been carried that when the work is finished it is even dipped in a dirty mixture to impart to it the appearance of age. But there is one peculiarity which

characterises most of the productions of both Shiba and Ota : they are decorated with figures of Buddhist saints, whose heads are surrounded each by a nimbus ; but I cannot learn that this mode of decoration was ever used in Satsuma ; and it is certain that if pieces of this character were ever made it was most seldom.

Yet both Shiba and Ota make other works which, although in some respects like the productions of the South, are altogether distinctive in their character, and have qualities which characterise the potteries in which they are made.

No works have ever been produced in any part of the world more lovely than some of those cups, kettles, and small vases fabricated during the last few years at Shiba. The delicate colour of the clay (which is vellum-like), the soft tints of the ornament, the exquisite diapers with which the objects are covered, the precision of the work, and the relation of figured surface to plain, make these fit objects for any boudoir in the land.

At Ota is produced the celebrated Makudzu ware, which, in its way, has never been surpassed. Indeed, some pieces of Makudzu ware are so wonderful that they appear to be *tours de force* rather than works produced for the ordinary purposes of trade.

We first became acquainted with Ota pottery at the Philadelphia Exhibition, where two indented spill vases, with lotus flowers in the indentations, attracted much attention. The esteem in which these were evidently held by those who saw them in America led the Makudzu<sup>1</sup> potter to experiment for new effects ; but in most of his trials he used modelled flowers upon his vases. When I visited the pottery at Ota he was busily engaged upon some fine works of this character, as well as with the formation of large old (!) pots with which to delude the American and European buyer. But it was at the last Paris Exhibition that we saw this great potter in his strength ; and he certainly showed himself as one of the giant ceramic workers of the world.

There are other places at which wares resembling those of Satsuma have been made, but Awata, Shiba, and Ota are the three places which furnish large quantities. Odd pieces made by

<sup>1</sup> This is not the real name of the potter.



other potters are sometimes better imitations of the original work than most of those made in the three districts named.

A notable example of this kind occurs in a vase made by Kawamoto Masukichi of Seto, which has the style of the old Satsuma ware in a marked degree, and which, although slightly grayer in colour, would be not easily distinguished from an original specimen.

There is also a beautiful ware of soft yellow colour, but slightly deeper in tint than even that of Awata, made at the town of Matsuye in Unshiu, and known as Unshiu ware; but this, until recently, was seen chiefly as tall teapots, spreading at the top, with a beautiful rich green running down one side, and on the other a tender spray of a gourd sketched in Payne's gray under the glaze, and with an arched handle formed from a stem of the *Westeria* creeper. Just recently this ware has, however, come into our markets in the form of cups, vases, and other things; and crude enamel painting has replaced the neutral decoration.

The early specimens of this ware were very pleasant and attractive, but those recently imported are altogether without art interest. But as these wares might possibly be mistaken for those of Awata by persons having little opportunity of study, and as Unyei, the owner of the Matsuye pottery, appears also to make a small quantity of imitation Satsuma ware, it has been thought well to mention his productions.

We sometimes see, even here in England, cup-like bowls, of a rather deep buff colour, with a crackled surface, and decorated with groups of small figures in somewhat strong colours. These were first made by a man named Shiuhei who worked in Kioto, where he but recently died. Some cups made by Ninsei—a man whose real name was Nomura Seibei, and who lived in the early part of the seventeenth century at Kioto—have also a resemblance to some specimens of Satsuma ware. Yet the works of this well-known potter can generally be at once recognised by the grayness of the earth, the prevalence of a gray-blue (of medium depth) in the decoration, and the fact that the designs employed on his wares almost invariably consist of the emblems

of long life—the stork, the fir, the tortoise, and the bamboo, while the works of the more recent potter are instances of Shiuhei ware, and are readily distinguishable from those of Satsuma, as the pattern consists of figures.

Kishiu ware, which has become celebrated in Japan, owes its origin to the ambition of a prince of Kishiu, at the beginning of the present century, to rival the fine turquoise blue of China. With this object he erected a kiln in the garden of his palace, near Wakayama, and summoned to his aid a skilled potter, from Kioto, of the name of Yeiraku Zengoro, who ultimately succeeded in making a ware of intense cobalt blue colour. This potter also made a rich purple ware, as well as pieces in which the two colours are mingled.

For a time this manufacture appears to have been abandoned, but some thirty years ago it was revived by one Miyai Sajōro, who lived in the village of Ota-mura, near Wakayama; but the wares that this man produced were generally bluer (had less of the turquoise hue) than the Kishiu ware now produced; and on most pieces made by this man we see a spray of a plant, or bits of irregular diaper patterns, painted, in neutral tint, beneath the glaze.

Nearly twenty-five years since Miyai Sajōro gave up manufacturing, and went to assist a widowed daughter to keep a shop in Wakayama; but about seven years since he returned to his native village, and resumed his old occupation. His wares are characterised by a preponderance of rich purple, and by a considerable mingling of the purple with blue; and he seems to have abandoned his early habit of placing sketches, in neutral tint, beneath the glaze.

Most of the Kishiu ware which we see in the English market is made near Hiogo by Horinouchi Sōzaburō, and more recently by men who have learned the art from him. The man here at Kobe tells me that it was he who rediscovered how to make Kishiu ware, and that Miyai Sajōro copied the art from him; but this, I think, cannot have been the case, as the latter practised his art at Ota-mura many years since, and he is much older than

the Hiogo potter. As to the merits of the two wares there can be no difference of opinion; for that made by Horinouchi Sōzaburō is undoubtedly the better. Much cheap and inferior work is now made for the European and American markets by those who have but recently acquired the secret of the manufacture.

Another class of ware of considerable importance is called Kutani or Kaga ware; but whether I am right in classifying it with works in faience is doubtful, for while some specimens have bodies which look like earthenware, it is in reality a crude opaque porcelain.

This manufacture was formerly carried on in the town of Kutani, in the province of Kaga, but it is now made chiefly in the village of Yamashiro.

Kutani wares are of two kinds—the one being decorated with flowers, figures, or landscapes, with these decorations drawn either wholly in red or in red, black, silver, and gold. The drawing is also frequently rendered, to a considerable extent, by dots. In England this is generally known as Kaga ware, whereas that we are just about to describe is generally called Kutani ware.

Made chiefly in the form of large bowls and saucer-like platters, this ware is bold in its treatment, and is decorated with flowers, birds, diaper patterns, landscapes, and, not unfrequently, with bold sprays of the bottle gourd. The colours used in it are chiefly the Kaga red, a full green, ultramarine blue, and black, with the addition sometimes of a pleasant Antwerp blue, a primrose yellow, a crimson pink, Vandyke brown, and a sort of purple-madder shade. In some cases gold is added.

In this ware it not unfrequently happens that part of the object is covered with diaper patterns on various coloured grounds; while birds or boldly treated flowers rest on these diapers. In another part will be arranged a panel, in which a landscape is painted. In most specimens of this ware the glaze will be found crackled to some extent. While Kutani ware is most commonly decorated in the manner described, many specimens have figures upon them. Being made in the province of Kaga, the two wares should perhaps be regarded as one; that which we distinguish

in England as Kaga ware has usually fine work upon it, and is in red alone, in red and gold, in red, gold, and black, or in red, silver, and black, as we have just said ; that which we know as Kutani ware is treated in a bolder manner, and usually has other colours than red in its decorations.

We meet with the same difficulties here as in other cases ; and I have now before me four pieces of ware which would be calculated to mislead the student. One is a little cup painted by an artist in Nagoya on Kutani earth ; one is a little hibachi or fire-pot made in Owari ; another is a bottle painted in the Kaga style, on a pure porcelain, at Tazimi in Mino ; and the fourth is an old Banko tea-jar decorated in the Kutani spirit. From a cursory glance it would be difficult to say where these specimens were produced ; but by the trained eye the Mino porcelain and the Banko earth would readily be detected. The Owari flower-pot would not, however, be so easily referred to the locality in which it was made, for it is a very close imitation of Kutani ware ; and the Nagoya painted cup, being decorated in the manner of Kaga ware, and being on Kutani earth, would defy detection. It was only through the accident of my getting it from the painter that I knew where it was produced. Old Kutani wares were always marked with the name "Kutani" and never with the name of the maker.

When speaking of wares that resemble the productions of Satsuma we mentioned that made by Sanpé of Awaji, but we did not mention the other wares which both he and Rikita—the two potters of Igano—make.

These potters concern themselves chiefly with the formation of small bowls, trays, caddy-spoons, and cups, which have an excellent finish. They are usually plain yellow, rich brick-orange, full green, or warm purple, in colour. But the three former colours especially characterise the Awaji wares. In some cases the little dishes and saucers which these men make have a dragon stamped into the earth, so that the glaze, by sinking into the depressions, shows as a deeper colour. Other specimens are in part perforated ; but most of them are perfectly plain.

Having enumerated the chief forms of faience, and the semi-porcelains and crude forms of "china," we come to the consideration of the porcelain manufactures which are now spread widely over the country. But although I visited nearly seventy potteries (sixty-eight), the rebellion that broke out in Japan during the time of my visit prevented my seeing more than three of the great centres of this interesting manufacture.

As we have already seen, the art of porcelain making was introduced from China at the close of the sixteenth century. Japanese who settled in Hizen (where much porcelain is manufactured to this day) brought the art to the country.

As this is the oldest seat of the manufacture, we may begin our notice of the different porcelains by speaking of those in this district. Made chiefly in Arita, these wares are called by the name Imari or Hizen. It is this ware which became known to Europe at an early time through the Dutch who occupied the island of Decima, near Nagasaki, from which Arita is only about forty-five miles distant: and it was this ware which became so much copied on the continent of Europe and in England. Some of the earlier works of Worcester are almost exact reproductions of Imari designs. As we shall have to speak of the methods of manufacture shortly, we need only point out at present the special features of the ware.

That which is most characteristic has a rich, deep blue, under glaze colour, produced from oxide of cobalt. On this are flowers and gold tracery; panels, bearing geometrical designs; diaper patterns, or drawing of foliage, landscape, or figures,—the whole being illuminated by the use of from four to six colours (often five) in which a red, similar to that of Kaga, green, and yellow prevail. Other specimens exist which are decorated entirely with shades of light blue; while some pieces have the centre treated in this manner, and colours on the border. A few pieces have their decorations formed of light blues, red, and gold only.

This ware has been so much copied in Europe that I cannot divest myself of the feeling that it lacks an Eastern aspect. But

this feeling arises from the fact that patterns which characterise Arita wares have been familiar to me from childhood, and I must confess that, viewed from an art point of view, it is to me the least satisfactory of all Japanese wares. The Imari potters work on a good body. They employ good colours, yet they often get a crude and garish effect. There are collectors in England who have a perfect craze for Imari ware; but when we consider the prices that have been given for pieces of old Derby, Bristol, and Worcester pottery, with little or no art merit, we do not wonder at persons being found who delight in surrounding themselves with numerous specimens from the potteries of Hizen. It is but too true that there are people who pride themselves on the number of their specimens, and prefer mere quantity to beautiful works.

There is one other important ware made in Arita which I have not yet mentioned—the Seidji or Celadon ware. This has a pale sea-green hue; but as this particular ware is now made in many parts of the country, and especially in Seto, it can scarcely be regarded as altogether characteristic of Hizen.

Like all other wares which have become famous, that of Hizen has been copied; and some of the patterns produced in Kioto, where, at the present time, Kanzan Denhichi is chiefly engaged upon such works, are similar, both in colour and form, to those of Arita. Care is needed to avoid mistaking one for the other. At Hirato, also, an island near the Hizen coast, small articles closely resembling the delicately painted blue-and-white wares of Imari are made.

We might now just mention a ware of some interest which was made in Kioto and bears the name of its inventor Eraku, as it is amongst the celebrated productions of the district. It is a pure porcelain, with a rich red surface formed of an oxide of iron, on which gold devices (generally of a mythological character) are drawn.

Turning to the better-known Kioto wares, we may notice that in Kioto much porcelain is manufactured, especially in the suburb called Kiyomitsu, not far from Awata, and here some objects of

great beauty and of singularly high finish are produced. The wares are of white porcelain tenderly decorated.

No potters in Japan seem to paint on porcelain with more tenderness than the Kioto artists. In some of their works there is a beauty of drawing and delicacy of execution which is most estimable; and some little cups which I purchased in the district are lovely specimens of work.

In Kiyomitsu, or the immediate neighbourhood, I visited seventeen potteries, amongst which were the most important in the district. The owners of these manufactories are Kiyomitsu Rokubei, Takahashi Dohachi, Kanzan Denhichi, and Seifoo Gōchio-me; but the two greatest are Kanzan Denhichi and Takahashi Dohachi.

A man called Kiokutei Seihichi makes eccentric though interesting wares.

But besides the manufacture in this district of Kiyomitsu ware, much pottery is produced from earths of various kinds, and no one district boasts more diversified talent than this suburb of Kioto. Were all the objects made in this suburb collected together one would suppose that they were the products of many towns.

In a district lying north of Hiogo called Sanda we find a series of little potteries, in which a Celadon ware is made, and which I, so far as I could learn, was the first European to visit.

Celadon wares are made in most of the great pottery districts of Japan, as I have just said, but in Sanda it is the chief manufacture. It is made in Hizen, Owari, and Kioto, but here it is produced only in small quantities, and is in no way the staple industry of the district.

The Sanda potteries (Sanda is the name of a district) are situated both in and near the town of Shidewara, and are five in number. Their owners are Konishi Tobai, Konishi Gohé, Kaméii Sadajiro, Uchida Hisakichi, and Konishi Tsunekichi. Of these Konishi Tsunekichi is father of Konishi Tobai, while Konishi Tsunekichi and Konishi Gohé are brothers. The Celadon wares made in this district are of an inferior class, and many pieces have pierced arabesque sides.

We may mention, in passing, the fact that besides the Celadon of this district rude wares of several kinds are here made. Amongst these are some of the roughest specimens of blue-and-white that could well be seen, as well as crude bowls bearing ornament in greens, reds, and other colours; but none are of interest save those for which the district is celebrated.

The next great seats of the porcelain manufacture are Owari and Mino, where most of the blue-and-white wares of Japan are made, and both districts produce wares similar both in character and merit.

Seto, a small town in Owari, twelve and a half miles distant from Nagoya, is wholly given up to the porcelain industry. In it are a number of potters, who all make blue-and-white wares. Some, however, make varieties of porcelain by no means characteristic of the district. The chief potters are Katō Mokuzayemon, a man who is said to be assisted with Government money; Kawamoto Masukichi, a prosperous man who has just built himself a beautiful house; Kawamoto Hansuke, Katō Shigeshiro, and Katō Gosuke, and each of these makes wares of great excellence.

The Mino potteries are situated in the villages of Tazimi and Ichi-no-kura, about thirty to thirty-five miles distant from Nagoya; but the better class of Mino wares are made in the latter village.

In Ichi-no-kura there are many potters, but the more important are Katō Shinbei, who is said to be the largest in the village; Katō Jiwsuke, Katō Kohei, Katō Gosuke (a namesake of the Seto potter), and Katō Kichibei.

Some of these men make wares the drawings on which are characterised by much delicacy. Deep cups have blue pencil-work upon them which is both minute and tender. On one I see grass, equisetums, dandelions, and the coranella, drawn with great fidelity to nature, and with almost microscopic minuteness; while on many of the sachi cups we have little diaper patterns, both varied and interesting.

As an example of the latter I may mention a specimen by Katō Gosuke, which is decorated both internally and externally



with little diaper patterns. The inside is divided into eight parts by lines radiating from the centre, and no two sections are filled with the same pattern. The exterior is divided in the same manner into sixteen parts, and no two of these contain the same diapers. Thus one section is filled with a simple arrangement of blue-and-white squares in the manner of a chess-board, another with a scale pattern, another with circles arranged in parallel lines, another with overlapping circles which intersect each other ; one contains a key pattern, one is enriched with a mere checker, one with a pattern founded on the hexagon, and another on diagonal lines. Others contain diapers based on the square, and, to heighten the pleasant effect produced, every second division is darker in colour than the intervening one.

While blue-and-white wares, if well manufactured, always look fresh and pleasant, I am not sorry that the rage for them is passing away. Excessive repetition of anything, be it ever so good, produces monotony. In order to make blue and white look well in our rooms the decoration must be of a certain character ; and no fashion can be satisfactory which compels us all to treat our houses in a similar manner.

An Englishman's house is his castle ; hence it ought to express by its decoration the mind, tastes, and knowledge of the owner. Were this the case there would be an interest in visiting each other's houses which is now lacking.

In wishing for the dethronement of blue-and-white I wish no harm to those good potters by whom I was so kindly received in both Seto and Mino. I am sure that they could make coloured wares novel in character and excellent in workmanship. At this present moment there are many men, both in Ichi-no-kura and Seto who devote themselves to the production of things quaint in character and novel in effect. Let them depart still farther from the beaten track !

If the potters of Owari are in any way suffering from the change in our taste respecting blue-and-white I should advise them to seek to produce novelties with soft effects of colour. Their present blue might be, to an extent, maintained, for the

love for Japanese porcelain is as great as ever it was, and the desire for novelties greater.

My visit to these seats of manufacture enables me to illustrate some of the difficulties which any one attempting to write an exact history of the Japanese ceramic arts must encounter. Thus in Ichi-no-kura I find one Katō Genjiw making wares resembling those of Banko, and even following the Banko shapes. Then, as to names, there is here a potter called Katō Kichibei who is known only under the cognomen of Hechibei, which means funny fellow. The fact that he makes curious wares and grotesque objects, together with the similarity between his name and the Japanese word *hechibei*, has caused him to be thus designated.

In the case of Kawamoto Masukichi of Seto there is a difficulty, for his wares are sometimes called by the name Hansuke, which was the name of his father, a celebrated potter. Yet this man has a brother, whom I also visited, who is now *the* Hansuke. The confusion is obvious.

The fact that the sons do not of necessity take the name of the parent, that the trade name is frequently a mere cognomen assumed by the manufacturer, and that this business appellation may be bequeathed to an apprentice or a son at the option of the parent, renders it most difficult to understand the actual state of things in a manufacturing district, and without great care confusion is inevitable. In England we should naturally conclude that a youth who succeeded to the business, who was called by the name of the manufacturer, and who used the seal or stamp by which the ware is known, was the son. But in Japan it very often happens that this is not the case. Another element of confusion is introduced by the chief name (that which answers to our surname) coming first; thus, where they would write Katō Kichibei we should write Kichibei Katō, and where they would write Katō San we should write Mr. Katō.

In going through the porcelain districts of Seto and Mino I found that some of the potters decorated their own wares, while others sent them to professional artists to receive patterns. Thus in the village of Tazimi I purchased a small sachi bottle, decorated

in the style of Kaga ware, which had been painted by an artist in the village ; and in Ichi-no-kura I found several men in business for themselves who undertook the painting of any wares entrusted to them. In Ichi-no-kura one of the chief men thus engaged is Katō Hichibei, a namesake of the "funny fellow."

I also found that much of the better wares from both Seto and Mino were sent to Nagoya to be decorated, where the two chief artists who undertake this work are Yokoi Sōsuke and Suyemoto Suzukichi, the former being eminent as a painter of gold work on an iron-black ground. But in the Seto district where the manufacture itself is carried on I did not notice the same number of men employed as professional artists as I did in the Mino towns.

If the artists who live in the pottery districts, and decorate wares, have but little work on hand, they make purchases of "shapes," which they decorate and sell. Thus, while the two artists whom I have named in Nagoya undertake work for the chief potters, they also decorate wares which they have purchased, and these they offer in the market with their own names affixed.

Objects decorated in Tokio are common in the English market ; but there is no place in Tokio that I am aware of, save the Shiba pottery, where any good wares are made ; and most of that which here receives pattern has been purchased in either Seto or Mino in an undecorated state.

In Tokio I have never seen any pottery decorated in more than a very second-rate manner by the professional porcelain painters. The Shiba pottery turns out some exquisite things, and so does that of Ota, near Yokohama, but here works are both made and decorated. Those who are engaged as mere painters in Tokio have never, so far as I could learn, produced work of a high character.

The Shiba pottery, and that of Ota, have turned out some grand vases, platters, incense-burners, and other things ; and to these potteries we are indebted for most of those specimens figured with saints which have been attributed to Kioto workmen. I also think that all those examples with black grounds which have been

referred by even our best collectors to the Satsuma district, were produced within the last few years at these places.

If a potter finds that any one class of ware has a high market value, and he is desirous of deceiving, there is no difficulty in his getting the clay from Kagoshima, or in his making a similar "body;" and it is certain that a large number of even the fine works which we in England attribute to the South have been made in Shiba and Ota.

That Kioto has long been engaged in the manufacture of both porcelain and faience is certain; but the things produced, until a comparatively recent period, were insignificant as ceramic works. For many days I devoted my attention, almost wholly, to the Kioto potteries and their history; and both in Kioto, Osaka, and other towns, I sought specimens of the old Kioto wares. I always found that they were rather curious and quaint than fine examples of work. In Tokio I consulted the various leading authorities connected with the Imperial Museum upon the early ceramic productions of Kioto, but I never saw a highly decorated vase that was not small, nor one example decorated with nimbused saints which was attributed to the district; while I not only saw scores attributed to the two Northern potteries, but I saw such at the works themselves in process of manufacture.

That important works in faience or porcelain were not produced in Kioto, even at the end of the sixteenth century, seems clear; and Kæmpfer's remarks on Miaco (Miaco is the old name for Kioto), made in the year A.D. 1690, would bear out my statement:—

"Miaco is the great magazine of all Japanese manufactures and commodities, and the chief mercantile town in the empire. There is scarce a house in this large capital where there is not something made or sold. Here they refine copper, coin money, print books, weave the richest stuffs with gold and silver flowers. The best and scarcest dyes, the most artful carvings, all sorts of musical instruments, pictures, japan'd cabinets, all sorts of things wrought in gold and other metals, particularly in steel, as the best temper'd blades and other arms are made here in the utmost perfection, as are also the richest dresses, and after the best fashion, all sorts of toys, puppets, moving

their heads of themselves, and numberless other things, too many to be here mention'd. In short, there is nothing can be thought of but what may be found at Miaco, and nothing, tho' ever so neatly wrought, can be imported from abroad but what some artist or other in this capital will undertake to imitate."

Although Kæmpfer says, "there is nothing can be thought of but what may be found at Miako," the very fact that he does not mention the ceramic manufactures, when enumerating the industries of the city, would at least lead to the conclusion that they were not of special importance in his time; and all my investigations while in Japan led me to conclude that no important works resembling the Satsuma wares were made in the old capital up to a recent date.

Besides the regular porcelain artists of Tokio there are a number of men who paint sachi cups (which are made in Seto and Hizen), and who sell these at little stalls. Such men generally paint over the glaze with a full ultramarine blue colour and gold, and they figure their wares and mind their stalls at the same time.

It is curious to watch these poor artists, at one time intent upon their painting, at another serving a customer, and at other times calmly smoking their pipes while taking care of the little portable kilns in which they are firing their few wares.

When in use this little kiln is generally placed in the doorway of the cottage. It is about eighteen inches in height by fifteen in width, and would to us appear a mere toy; yet the poor artist watches over the firing of his wares with the tenderness of a mother over her sleeping child. While his wares are in the kiln he appears to devote himself wholly to his fire and his pipe; yet if a customer should appear, he will attend to his wants at the little stall which stands in the front of his house.

In this notice of the ceramic manufactures I have tried to distinguish between the different forms of faience and those of porcelain, and have spoken of the places in which each are made. This classification is apt to be misleading, for in most of the pottery districts both wares are made.

If we visit one of the chief potters of Kioto we shall find

that he makes both porcelain, earthen goods, and stone-ware. Thus that celebrated man Kiyomitsu Rokubei we find engaged in the manufacture of exquisitely finished porcelain teapots, cups, and vases, some of which are tenderly painted, while some have sprays raised upon them by "slip"—pâte-sur-pâte.<sup>1</sup> Others have the rich blue surface which characterises the old Worcester work, with white sprays also raised in slip. But this man also makes rough objects in a coarse yellow earthenware, curious embossed tiles, irregular lumps of clay which he glazes and employs as the pavement of his garden paths; indeed, there is scarcely a form of pottery ware that this manufacturer does not produce.

The same remark applies to Ichi-no-kura, for here one man makes wares resembling those of Banko, as well as blue-and-white porcelain and dark metallic-looking pots, while others are engaged in manufactures widely different from those which characterise the district.

No further trust can be placed in the potters' marks than in the character of the wares themselves. One man will sometimes use two or three marks; as his own trade name, the trade name of his master, and the name of the district in which he works.

Having seen the manner in which trade marks are applied, even in those cases where deception is not aimed at, I have often been amused at the pertinacity with which many in England maintain the infallibility of such stamps. It is only too apparent to those who have travelled in the country and visited the seats of industry, that the attempt to fix the names of the potteries at which pieces have been made, the artists who made them, or even their dates, must be useless, save in the case of a few men who have become famous. But even these may be confused with deceptive imitations made for sale in the European and American markets, or with the works of the favourite apprentice who has succeeded to the business and imitated his master's style.

As an artistic manufacture the ceramics of Japan differ widely from those of ancient Greece. Greek pottery had a beauty of form which has never been equalled in any other nation. Beauty

<sup>1</sup> "Slip" is clay in the form of batter.

of line and tenderness of shape characterised the works of both the Greeks and Etruscans. But while these peoples produced forms of matchless grace, and while the Greeks painted upon their works ornaments beautiful in form, simple in treatment, and arranged with the utmost regard to quantities, neither the Greeks nor the Etruscans knew anything of the varied and subtle processes by which the Japanese give variety to their wares.

The Greeks produced no porcelain; and variety, even in their earthenware, was most limited, while in Japan the methods of work are well-nigh innumerable.

As regards beauty of form, it must be admitted that the Japanese are far behind the ancient Greeks, and Japanese shapes certainly often display quaintness rather than grace. Yet as there are in Japan many shapes which are beautiful even when compared with the Greek standard, so there are also many which are somewhat clumsy, awkward, and what we might call, podgy; while others are bounded by heavy curves instead of lines of beauty.

Humorous eccentricities account for many of the forms found in the pottery of Japan, while others are explained by reference to the natural objects common in the country.

As illustrations of forms resulting from the sense of humour, I may mention certain objects which are before me—as a teapot in the form of a frog—the mouth acting as the spout, another teapot in the form of the fingered orange already mentioned, another in the form of a duck, another in the form of a swallow, while another simulates a portion of a tree stem from which a branch with flowers protrudes as the spout.

Of the second class we have many examples; thus, cups in the form of the lotus leaf are welcome to the Japanese, as the *Nelumbium* is Buddha's plant; and the prevalence of cylindrical vases (the "spill" shape) is due to the fact that many of the vessels of daily use are cut from the stem of the bamboo, and of necessity have this shape. But the most characteristic form in the common pottery of Japan is that of the gourd.

In glancing round the room in which I sit I see more than twenty specimens derived from the bottle, or pilgrim's, gourd, but

in these I only include such as have the contraction in the centre, like the old hour-glass ; yet the onion-shaped bottle with a long neck, such as we so often see in Kishiu ware, is undoubtedly derived from another and equally characteristic form of gourd ; and while primitive man has frequently made his drinking cups from portions of the gourd shell, such vessels may be found in use at the present day in Japan, together with earthen pots having forms similar to the natural object. Ladles formed by the longitudinal splitting of a long-necked gourd are also common in the country.

Before me, in porcelain or earth, lie long gourds, short gourds, broad gourds, narrow gourds ; gourds with the upper and lower distensions almost of the same size, gourds with the lower distension large and the upper small, and gourds bent in various manners. One gourd is a sachi bottle, one a teapot, one a sauce bottle, and one (or rather half a one) a ladle ; while, if we were to include the long-necked bottle, with the one globular bulb, and the common sachi cup (for it was a bottom portion of a gourd), amongst the vessels derived from the gourd, the specimens met with would be simply innumerable.

While speaking of the gourd, we may mention that its form in pottery ware is by no means peculiar to Japan, for it is equally common in China and Morocco : and even in Central Africa a similar thing occurs ; for here we find rude metal vessels which are mere imitations of the carved calabash shells of the district.

In some cases the gourd form is somewhat strangely used ; for some vessels may be regarded as formed chiefly of a tube having the sectional form of the gourd or hour-glass. Here, before me is a teapot so shaped, and with the ends made of flat pieces of this gourd-like shape. An earthenware basket which I bought in the Sanda district is of this shape. But here the tubular portion is large and short, and stands vertically. It has a flat bottom and an arched handle.

It would be easy to furnish many illustrations of the manner in which the Japanese have derived the forms of their wares from natural objects ; but having called attention to the fact, I must leave the reader to pursue the inquiry for himself. Could we extend



our researches to all branches of manufacture, and to all countries, such an investigation would have great interest, but as we must confine our remarks to pottery and to Japan, the inquiry loses much of the fascination which it would otherwise possess.

Comparisons, it is said, are odious; yet in considering the manufactures of a country we may reasonably try to estimate their true value, especially when a nation has produced such works as command the attention of the world. I must say that in form the Greeks stand pre-eminent, that the Chinese and the Moors perhaps come next, then the Persians and Indians, while the Japanese lack tenderness of shape. But in other respects I think that Japanese works take a first place; and I cannot help feeling that the best productions of Ota, the finest works of Shiba, and the choicest cups of Satsuma, are things unsurpassed in the potter's art, and that some of the later works of Kioto are fit for a place in the best boudoir in the land.

Respecting the manufacture of porcelain and faience something must be said. It may be remembered by those who visited the Philadelphia Exhibition that the Japanese there showed those materials which are spread so widely over the country, and are used in the pottery manufactures, as clay, kaolin, silex, etc. In the official catalogue of the Japanese section of this exhibition, we are told that "in many instances very good ordinary refractory materials and fine porcelain clay are found close together. This is the case to a most remarkable degree in the neighbourhood of the small town of Arita, province of Hizen, the head centre of the porcelain manufacture in Japan. Within a very limited circuit, not half a mile in diameter, there are found embedded in the rock at different places all the materials necessary for the biscuit, for the coating of the ware before glazing, for the glaze, for the craquelé, etc., the best being of such good quality that, after being powdered and decanted, it is used without any further mixture for the finest ware,—the so called egg-shell porcelain. In the central part of Nippon,<sup>1</sup> where granite is the principal constituent of the mountains, in the provinces of Owari, Yamashiro, and the island

<sup>1</sup> Japan.

of Awajishima, opposite Hiogo, beds of petuntse, very much like the Bohemian material, are to be found. When used for porcelain, this material is mixed with silicious and feldspathic materials from other places."

This is what the Japanese say respecting the materials with which they fabricate their ceramic wares ; but the ordinary wares of Awaji, we are told, "consist of a strongly baked biscuit, chiefly composed of kaolin," and that they are "glazed with a very fusible mixture of sand and oxide of lead, which, by an addition of copper oxide or certain naturally-coloured clays, assumes a green, yellow, or brownish-red colour."

Before making any comments of my own on the processes of manufacture, I think it well to extract from the Philadelphia catalogue their own description of the porcelain manufactures, which is as follows :—

"The art of porcelain making presents features which, of course, in principle, are very similar to those of porcelain manufacturing in Europe ; however, the machinery used is of a more primitive kind.

"Whatever may be the nature of the raw material, be it quartz, felsite, kaolin, feldspath, or the peculiar porcelain-stone of Arita, it is always powdered by means of balancing pounders of a peculiar construction. These are composed of long horizontal beams, with a perpendicular cross piece at one end, giving the whole the shape of a hammer, and with a water-trough at the other end. This instrument is put up wherever a small stream of water can be utilised ; the water running into the trough raises the poulder by over-weight, and running out at the end in consequence of the incline, allows it to fall down again, with the iron-shod cross piece dropping into a stone mortar, in which the materials are thus reduced to powder ; the latter is then sifted, mixed with water, and decanted.

"No other machinery, such as the quartz or glaze mills of foreign porcelain manufactories, is used, and the consequence is that all the material which cannot be sufficiently powdered by the above described pounders—amounting often from forty to fifty per cent—is thrown away as waste.

"The fine powders produced by decanting are carefully mixed and removed into flat boxes, where the water is partly drained off through a sand bedding covered with matting, and partly tapped off from above the deposed clay ; the latter is finally brought to more consistency by placing it on the warm furnaces. Long experience, combined with the good quality of the raw material, enables the manufacturers to prepare a clay fit even for the production of very large pieces, such as vases from six to seven feet in height. These are chiefly

manufactured in Arita; whereas porcelain tables, painted slabs, fireplaces, and similar articles, are mostly made in Owari. The throwing and shaping of the clay is done upon the common potter's wheel, which, in the town of Arita (Hizen), consists of a flying wheel and a working disc, twelve or fifteen inches one above the other. These are united by a sort of hollow wooden prism, so as to form one system of wheels, which is placed over a vertical round piece of wood fastened in the ground. To avoid friction as much as possible, this system of wheels is resting upon the pointed stick by means of a hollow piece of porcelain set underneath into the working disc. By means of this lathe the workmen in Arita turn out large dishes of three feet in diameter, as well as the so-called egg-shell porcelain, not thicker than paper. For very heavy and large pieces the lathe is turned by means of a driving-cord.

"In all other provinces but Hizen the lathe is of a more simple and imperfect construction, the flying wheel being at the same time the working disc.

"Moulds are also used, and made of ordinary clay. Since the Vienna Exhibition the use of gypsum for moulding is taught to the porcelain manufacturers of different places, and will most likely effect an important progress. Some of the pieces exhibited at Philadelphia have been made by the new process.

"When the pieces have been sufficiently dried in the open air they are shaped with sharp iron tools on the same lathe on which the first throwing has been done, and are then coated with a very pure white clay, so as to give the finished ware a better appearance, and to bring out with more intensity the fine blue colour of the cobalt painting. After this coating the ware receives the preliminary baking in small kilns built in the open yards of the manufacturing localities. The pieces are then painted with the oxide of cobalt, and afterwards glazed in the same way as in Europe. The glaze is always composed of a feldspathic material, either natural or produced by the mixture of different minerals, to which is added a certain quantity of wood ashes freed from the alkali by careful lixiviation. The proportion of ashes depends on the place which the pieces have to occupy in the kiln, the heat of which is not quite uniform. With reference to certain peculiar kinds of porcelain, such as the Celadon or the craquelè, the materials used are not the same as for the white or common ware. For the Celadon the body is the same, but the glaze is made of a mineral different from that which is used for the glaze of the white ware. The craquelè, *i.e.* the body of the craquelè, is made from a peculiar kind of porcelain stone; but the nature of the network of cracks, the size of the meshes, etc., depend not only upon the thickness of the glaze and of the white coating underneath, but also on the degree to which the piece is baked before and after glazing. The ware is finally rubbed over with Chinese ink, so as to render the cracks more distinct.

"The kilns are of a peculiar construction, and are always built on the slope of a hill, in a line of from four to twenty, according to the importance of the

locality. The base of each kiln lies about three feet higher than the base of the foregoing one, so that, if all the kilns were uncovered, the whole of them would present the aspect of terraces formed by a series of platforms, each three feet high. The ground-plan is in the form of a rectangle, or rather of a trapezoid, the kilns growing wider and wider as they extend up the hill. The walls on the four sides of the ground-plan being vertical to the height of a few feet above the base, gradually form a vault, the corners of which have been rounded off in such a way that the upper part of the vault presents no corners at all. This somewhat complicated shape will be more easily understood when it is stated that one of the large kilns in Arita has a length of twenty-seven feet, a depth of eighteen feet, and a height of fifteen feet in the centre. The central section by the depth would resemble half an ellipse, with the principal axis in a vertical position, while the section through the length of the kiln would be half of an ellipse, with its principal axis in a horizontal position, and raised three or four feet above the ground. The front wall of each kiln, *i.e.* the wall facing the lower end of the line of kilns, is pierced on the level of its floor by a series of holes eight to twelve inches high, and three to four inches wide; and in the opposite wall, which, on account of the trapezoidal ground-plan of the kiln, is a little longer than the front wall, there is a second series of similar holes, but at three feet above the floor, and consequently opening exactly upon the floor of the next kiln. In this way a draught is established through the whole line of the kilns, which ends in a range of short chimneys, corresponding to the draught-holes of the last kiln. There are no separate furnaces or fireplaces, but the fuel is thrown directly into the kiln. For this purpose a space 0 m. 70 to 1 m. wide has been reserved along that wall of the kiln, the air-holes of which open immediately upon the floor, and is separated from the main part of the kiln by thick perpendicular fire-clay slabs about 30 m. 0 to 1 m. high. This separate narrow space communicates with the outside by means of an opening, 0 m. 50 high and 0 m. 15 wide, made into the side wall of the kiln. Through this opening the fireman very dexterously throws dried wood into the kiln, three pieces at a time; and, notwithstanding that the kiln is sometimes 8 m. in length, fires it with all the required regularity. The current of air passing through the lower kilns reaches the wood through the holes in the front wall; the flame, deviated by the upright fire-clay slabs, does not strike the porcelain directly, but follows the vault, and the heat spreads more equally amongst the objects placed in the kiln. The opposite part of the vault is purposely made steeper than the side whence the flame starts; consequently, the latter does not take the straight line to the opposite holes, but produces a sort of whirling fire, which takes the objects also from behind. The flame passing through from the lower kiln, where the firing is actually going on, into the following kiln, produces sufficient heat to render this latter red-hot by the time that the firing is finished in the first. At this moment the opening through which the first kiln has been fired is closed up with fire-bricks, and the firing begins in the second one.

“By this arrangement, the principle of which is very similar to that of the modern circulating furnaces for burning bricks, the fresh air has to pass through the kilns that have already been fired, and reaches the wood with a high temperature, producing combustion on most favourable conditions, while the departing flame is used for heating the next kilns. Since each kiln is heated by the fire of the foregoing ones before its own firing begins, it profits by an amount of heat which is the greater the farther up its place in the line. This explains why the manufacturers have thought it to be more advantageous to construct the kilns of increasing size in following the line upwards. At Arita, for instance, the lowest kiln has a length of seven feet, a depth of six feet, and a height of six feet, whilst the last one is twenty-seven feet long, eighteen feet deep, and fifteen feet high. The single separate furnace to begin the firing is situated at the lowest end of the line. The fuel is pine wood, which has been barked and dried in the oven. It may be remarked that the firing, even in the larger kilns, does not generally last more than fourteen hours; but it should be borne in mind that they are already red-hot when the firing begins.

“The setting of the pieces in the kiln is done with precautions similar to those observed in Europe to prevent their distortion. The only difference is that in general only a small number of pieces are protected by fire-clay boxes or sappers, while the greater part are directly exposed to the fire; but in this respect improvements have been lately introduced by some of the principal manufacturers.

“In order to prevent the dust from falling down from the vault, the inner surface of the kiln is coated with a glazing mixture before the firing begins. The pieces are arranged upon fire-clay stands, made in the shape of round tables, and placed one upon another to a height which a man can easily reach. The upper half of the large furnaces remains entirely empty, but surplus height of the vault is necessary to prevent it from caving in, which would certainly happen were it too flat.

“The kilns are constructed in a manner which has the great advantage of being extremely cheap. When the floor is prepared and the side walls erected two or three feet above the ground, a centering is made by placing within this space one or more poles made of young trees, with the branches cut in such a way as to give the upper end the shape of a fork. The length of these poles corresponds to the height of the vault in the place where they are erected. Young pine-trees are then fastened along the inner side of the walls by one end, then bent over the uprights, and fastened with straw ropes in such a way that the whole centering represents a vaulted network with wide meshes. Long strips of bamboo are then tied to the main centering, so as to produce, finally, a sort of basket-work, leaving only such small interstices that the building material cannot fall through. A mixture of fire-clay, powdered, and broken fire-bricks, with enough water to give the mixture sufficient plasticity, is now placed on the centering. The kiln-builders, using their hands only, cover the centering with this mixture, taking great care to make it as compact

as possible. When the material has settled down and has become sufficiently dry, without entirely losing its plasticity, the exterior is beaten with heavy wooden mallets in order to harden and to smoothen it. The vault is now solid enough to stand without the centering; this is thereupon taken away, and the inside smoothened and hardened with small mallets. When repairs are necessary, the damaged part of the kiln is broken away, and a centering built at the required place in the manner described above; whereupon the whole is filled up, this time with fire-bricks and not with the above-mentioned mixture. Thus, after a certain number of repairs in different places, almost the whole of the vault becomes composed of fire-bricks. These kilns are said to last fifteen years, and even the largest do not cost over sixty dollars. Their shape and dimensions vary in the different provinces, the walls being more or less steeply vaulted. The above description refers to those kilns of Arita which seem to be the most perfect. The kilns used for baking the porcelain before glazing are of a similar shape, but smaller and always single, each manufacturer having his own kiln on his premises. But the finishing kilns belong to the community, and are situated here and there on the boundaries of the town or village; they are rented to the different manufacturers. In the town of Arita their number amounts to over two hundred, and they are fired in turns, so that each kiln is used only six or eight times a year.

“The greater part of the articles which are baked in these kilns belong to the kind called ‘Sometsuki,’ or porcelain decorated with blue paintings underneath the glaze; this is done with a native cobaltiferous ore, or with a purer material imported from China. Almost all the ware made for home use is ‘Sometsuki.’ Another part is left white in order to be decorated on the glaze with coloured enamels, which have to be baked in peculiar furnaces at a lower temperature. This kind of porcelain is manufactured chiefly in Hizen, and mostly for the foreign market. The chief ingredients of the enamel consist of powdered glass (a sort of flint glass composed of silica, litharge or red lead, and nitre), with an addition of white lead or of silver powder in various proportions, for the purpose of giving to each enamel a proper fusibility.

“The colouring oxides to be mixed with the flux are very few in number, viz. copper, manganese, antimony, red oxide of iron, impure oxide of cobalt (for the black), and a sort of smalt from China; finally, gold for carmine tints mixed with powdered glass, and for gilding with a slight addition of white lead or borax. None of these enamels are melted beforehand in a crucible, but the ingredients are mixed by the painter himself and used directly for painting, so that the green, the yellow, the violet, etc., only appear when the pieces are baked in the muffle. Of later years foreign enamels have been used, but the painters are more and more inclined to return to the original native style of decoration. Porcelain painting, to a much smaller extent than in Hizen, is done in Owari, Kioto, and in Yedo, on white Owari ware.

“The manner in which this decoration is produced differs very much from the European method. In the first place, the whole design is traced in black

lines, and the shades, when at all, are only indicated by strokes. The coloured enamels are put on either in a thin layer when they are opaque, such as the red, the yellow, and the black, or in a thick layer when they are to produce, after melting, the effect of coloured glass, through which the black tracing of the design is visible. Sometimes relief paintings are produced by first coating the porcelain with a white opaque enamel, which contains no oxide of tin, but is merely a mixture of glass, white lead, and powdered stone, and on which the other colours are then painted. Generally speaking, the whole decoration is finished in one baking; very seldom it requires to be baked a second time. As to the character of the Hizen porcelain decoration, it is so well known in foreign markets that it needs no special description. In Owari, Kioto, Mino, the great bulk of the porcelain consists of blue ware or Sometsuki; but a remarkable article produced in Kioto is the Eraku ware (so named after the inventor), which consists of porcelain painted over with red oxide of iron, on which ground all kinds of mythological ornaments are applied in gold.

“Kaga ware is decorated in a most characteristic way. It is distinguished by the very fine gold ornamentation, generally on red, sometimes on black grounds, leaving open fields with paintings of flowers, birds, or personages, either dressed in red or gold outlines, or painted with transparent enamels of a similar composition, as those used in Hizen. These latter paintings are characterised by the vigorous tracing of the black outlines under the enamels, and the power with which these latter have been applied. Although the ware in itself is not generally of a very fine quality, this sort of decoration in gold and red is very rich and most effective. In later years, when better white ware has been manufactured in Kaga, or imported from other places for decoration, one of the painters has produced some excellent specimens, presenting a happy combination of the painting in red, black, and gold outlines, with the above-mentioned peculiar style of decoration, originated by a celebrated porcelain-maker of Kioto, called Eraku.”

This is the description which the Japanese give of their own manufactures, and it is so accurate that it needs little comment. But with the view of rendering the nature of their kilns, and their mode of working, better understood, I give illustrations (Figs 172, 173, 174, and 175) which may serve to throw light on the explanation, and for these I am indebted to Dr. Roritz of Nagoya.

To me the description seems likely to mislead in this one respect, that while Japanese potteries are usually very small, this account would cause one to suppose that they are generally of considerable size. In Hizen there are potteries where a

number of men are employed, and in Mino and Owari there are also works which give employment to a score or more of potters ; but the great mass of those potteries, from which the



FIG. 172. - THE POTTER'S WHEEL.



FIG. 173.—THE PAINTER AT HIS WORK.

celebrated works proceed, have, as workmen, the master and a son, or the master and an apprentice, or, at most, the master and one or two others. I visited sixty-eight potteries, yet I never saw a potter's wheel of the description named by the Japanese in the Philadelphia catalogue.

In a paper which I read before the Society of Arts some little time since, I gave this as a description of the manner in which earthen vessels were usually made. "In a lovely little room, the floor of which was covered with mats, dwelt the potter . . . One mat being removed from the floor, a potter's wheel is exposed to view ; but the wheel is of the simplest character. It



is a mere circular stone, of the form of a Cheshire cheese, is level with the uncovered floor, and works on a vertical axis which is fixed in a log of wood beneath. At one side of the wheel is a clean tray bearing a lump of clay. At the other side is another tray, often well lacquered, on which the vessels, when



FIG. 174.—OVEN.

shaped, are placed. The operator now kneeling in front of the wheel, and sitting more or less back on his heels, sets the disc in motion by whipping it with the tips of his fingers till the necessary speed is attained in its rotations. He now places a piece of clay upon the wheel and gives to it form in the usual manner, stopping to whip the stone whenever it is necessary that its speed be quickened. In this way he shapes his wares."

I invariably found that where excellent work was produced things were on a very small scale; and that it was only in those cases where numbers of common things were made (like the ordinary wares of the country or those produced for the European and American markets) that anything like a factory system existed. It is important to remember that a Japanese potter, lacquer-worker, or other handicraftsman, may become as famous as a Landseer or a Turner, and that works bearing his signature will be as much sought after by the natives as those of any of our "great masters" are by us.

Such men are invariably lost in their art. They give them-

selves up to the production of the excellent, the beautiful, the lovable ; and whether their food is of the poorest or the best they do not seem to care. Their whole pride lies in the production of meritorious works.

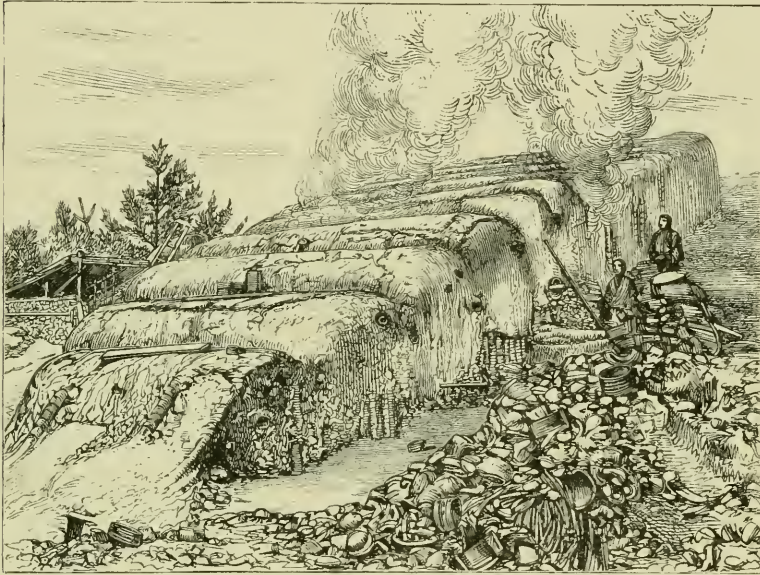

FIG. 175.—KILN.

In buying from one of these men a specimen of his work I found that he could not count money, and that he had little or no idea of its value. The buying and selling was done exclusively by his wife and daughter ; and as the money system had changed much in the last twenty years, this poor but skilled workman had failed to keep pace with the day. His life had been wholly consumed in his work.

This was by no means a solitary case ; and it is only under similar conditions to these that we get those grand objects which both we and the Japanese so much value. Whenever these men part with a work they are most particular in placing it in a beautifully finished pine-wood box, on which they place their

autograph and seal (red stamp), and in wrapping the box in paper which they again sign. None but ordinary works are sent out without being thus packed.

Happily for Japan the personal pride of a workman is as great as that of any of our artists or our sculptors.

## CHAPTER V.

## THE METAL MANUFACTURES.

THE art of metal casting is of great antiquity, and it appears to have been carried to a high state of perfection at an early period ; indeed, during the Middle Ages bronze casting, chasing, engraving, gilding, and the various processes connected with the goldsmith's art, were so perfect that they have never been excelled. This is at once apparent to those who have had the opportunity of studying the old swords with their various ornaments, and the large castings of Buddhas and of bells which may be seen in the country.

The traveller is astonished at the magnitude as well as the excellence of some of the metal castings which he meets with ; but in contemplating these works we should always bear in mind that they resulted from a national interest awakened by the priests.

In mediæval times the casting of a large bell, an image, or a bronze lantern, was a matter of public concern, and for the work the priests collected offerings of gold ornaments, of copper, and of other metals.

The Dai-butzu at Nara and Kamakura are the largest metal castings now existing in the world—that at Kamakura being forty-seven feet in height, while that at Nara is fifty-three and a half feet from the base to the top of its head. The latter of these enormous statues was first erected in the eighth century, but, being destroyed during the civil wars, it was recast about seven hundred years since.

In attempting to produce this enormous casting six failures were made, and it was only by the seventh effort that success was achieved. Three thousand tons of charcoal are said to have been used in the operation. We are told that the metal used in the production of this great *Dai-butzu* weighs four hundred and fifty tons, and that it is an alloy consisting of about one part of gold, four parts mercury, thirty-four parts tin, and nineteen hundred and seventy-two parts of copper.

Here, as in Europe, much of the best work of the Middle Ages was achieved in the monasteries, where religious enthusiasm and holy zeal led to that loving work which was ultimately fostered through the baronial system, when the skilled workman became the servant of a feudal lord.

It was in the eighth century that the Mikado became secluded; but it was not until the end of the twelfth century that Yoritoma (the first *Shôgun*) initiated the dual system of government by leaving Kyoto (with the officers of the internal revenue) for Kamakura, and establishing those conditions which led to the feudal system. Although the Mikado remained at Kyoto, Kamakura became the actual seat of Government, and was subject to Yoritoma's will. Five members of Yoritoma's family were now made governors of provinces; but before this time the governors were civil officers of the Court. The people were next taxed for the support of the provincial troops, who were subject to Yoritoma's relations, or to military rulers who were appointed as co-rulers of the provinces with the Court officials. Yoritoma thus gained a military supremacy which made him practically the ruler of Japan.

The power of this mighty ruler became increased through a conquest which he achieved in the north of the country. By way of a reward for this service he was received in great state by the Mikado at Kyoto; had valuable presents given to him, many of which I inspected at Kamakura and Nara, where they are still preserved, and was appointed to the important office of subjugating barbarians.

The military governors of the provinces gradually became more powerful, and with the increase of power came an insolent

and overbearing manner, which led to the Court governors of provinces being entirely superseded by military authority. Thus the military rulers gradually became feudal lords, each of whom commanded a certain number of armed men ; but all were subject to the Shôgun, or chief of the barons, who held a power from the Mikado by which he could reward acts of prowess, or any conduct which he personally approved.

Thus was established a system which did much to foster art in the country. Prior to the time of Yoritoma handicraftsmen were found chiefly in the Buddhist monasteries, where the quiet and leisure necessary to the production of great art works could alone be enjoyed. But no sooner was the feudal system established, by the military rulers of provinces becoming Barons or Daimiôs, than a fierce persecution of the Buddhist monks took place, when the power of the priesthood was to a great extent broken. The newly established rulers of provinces now sought skilled workmen who could manufacture objects such as they themselves desired to use, and which might serve as presents worthy of the acceptance of the Shôgun or other barons. These workmen became part of the household of the lord for whom they wrought. They lived in the precincts of the baronial palace ; they were fed and clothed as the servants of the household ; they were allowed to marry ; and received presents or favours in return for the production of works having special merit.

For seven centuries the best art work of Japan was done under the conditions of rest and leisure enjoyed by artists working under the baronial rule, just as the best work had formerly been done in the seclusion of the monastery.

Metal-work, especially, prospered during the earlier part of the feudal period, for not only were good sword-blades necessary during the periods of civil war, but officers of rank, as well as the Daimiô himself, sought to have their sword and armour adorned with metal ornaments of marked beauty. On the perfection of these enrichments, both as regards workmanship and art, they especially prided themselves.

Our first acquaintance with Japanese manufactures revealed

their skill in the casting of metals. But it was the Vienna Exhibition which showed what supreme casters of metal the Japanese are. In this exhibition was shown a casting of a flight of birds, which may now be seen in the Archæological Museum at Edinburgh. The birds are so arranged that the group forms a continuous casting. Yet the birds composing it are almost separate the one from the other. This casting is the work of a Tokio manufacturer of remarkable ability.

So far as I know, this was the most notable work ever produced by the flowing of molten metal into a mould. But even this marvellous work was surpassed by a peacock sent to the last Paris International Exhibition by the same wonderful metal founder.

This peacock, which was of life size, had a drooping and unspread tail, but many of the feathers, and even barbs of the feathers, were distinctly rendered ; while in many cases the barbs were separate the one from the other, and the individual feathers more or less distinct.

Up to the time when this marvellous casting was brought before the eyes of Europe nothing approaching it had ever been produced, I believe, by any people or in any time ; but before the close of the exhibition in which this was shown, Messieur Barbedien of Paris added some truly remarkable works to his exhibit, which, while smaller than the Japanese bird, were equally difficult of production. But were I to guess how he accomplished his work I should say that he had learned the Japanese secret, and adopted their method of work.

While in Tokio I had the opportunity of seeing the little foundry of the great metal caster who sent these marvellous objects to Europe, and he most kindly showed me how he achieved his results.

The great peculiarity which I noticed in the Japanese method consisted in a fresh model being made for every work produced. Thus, if fifty kettles were to be formed of the same pattern, not only would a fresh sand mould be made for each particular kettle, but a fresh model would be prepared for the making of each mould.

All must now be familiar with those beautiful iron kettles

which have become so fashionable for the afternoon tea-drinking, and which frequently have a flower or some other device jutting out from the side in almost full relief. These are of Japanese manufacture, and while the body is of iron the lid and the handle are generally of bronze (Fig. 176).

To produce such a kettle a block of wood is turned to the shape of its body, and the spray, or whatever ornament is to appear on the finished work, whether it be simple or most elaborate, is modelled in wax on this "core," a separate process of modelling being necessary to the production of each particular kettle.

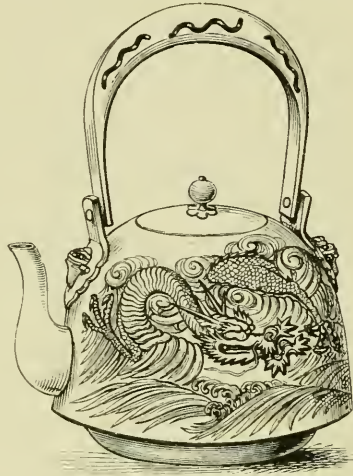

FIG. 176.—CAST-IRON KETTLE, with lid and handle of bronze.

It will be seen that this process, although laborious, gives variety and interest to the works produced; and while all such methods must seem to us to involve an unnecessary expenditure of labour, I yet think that the Japanese gain as much as they lose by their processes.

Nothing is so calculated to remove from man a true perception of art qualities as seeing hundreds of works precisely alike. The mere fact of seeing a number of duplicates of the one thing, however meritorious each may be, is calculated to weaken our appreciation of the beautiful. The multiplication of examples inspires dislike, though the work itself may be worthy of admiration.

No one would like to see his walls covered with fifty copies of Landseer's "Last Mourner," Herbert's "Man of Sorrows," or Frith's "Derby Day," even if each one were painted by the same master. So is it with reproductions of art objects of any kind. There is something about numbers which in some way detracts from our appreciation of the object multiplied.

The Japanese method of casting gives a certain amount



of variety in the work produced, for no two objects are precisely alike. And each has a special character resulting from the personal work of the modeller.

It is this quality which causes those who have art appreciation to prefer Japanese kettles to anything that the black countries have yet produced.

Whether the work be large or small a model is first made on a rough piece of wood, to which shape is given by the addition of a mixture of wax and resin ; but in the case of long feathers or other fragile parts the wax would enclose such wires or bamboo slips as would be needed for their support.

The model being prepared, a thin batter is formed by mixing a sand of exceeding fineness, and almost clay-like in character, with water. This is carefully spread over the model in such a manner as to coat it all over. But care must be taken to leave no air-bubbles between the wax and the sand. When this batter is dry a second coating is given, and then another, but now the batters are formed of a slightly coarser sand. If necessary, other coats are placed over the whole or part of the work. When these are dry sand is piled around the mass and pressed into all the spaces which have been but partly filled by the semi-fluid matter, till the whole appears as one shapeless but solid mass.

The next process consists in removing the model with its surrounding sand to a sort of kiln or "muffle," in which the heat is sufficient to melt and evaporate the wax, and even to consume the wooden core should any exist. Certain holes have necessarily been left through which the metal is to be introduced to the mould, and also holes by which air is to be expelled at the time of casting. Through the holes any dust or ash can be removed from the mould.

By this process of melting the wax, and evaporating it through the body of the sand, a firmness seems to be produced in the mould which our moulds lack. But the fact that the wax model is first coated with semi-fluid matter does much to attain this end. It is well known that if a pint of fine sand is placed in a vessel, much water may be added to it with the result of

diminishing, rather than increasing, its bulk. Particles of matter adhere more closely together when floated in water than when in air, and it is owing to this fact that we are able to make paper, for the particles of vegetable fibre, being floated in this medium, are brought into close contact and entangle themselves together.

I had no opportunity while in Japan of seeing the actual process of casting carried on, I only saw the making of models and moulds ; but from the explanations given to me by various workmen it seemed to differ in no essential particular from our own. I was, however, told that the moulds were made hot before the fluid metal was poured into them, so as to prevent its chilling while flowing through fine ducts. This I think highly probable, for by no other method that I know of could such work as the tail of the great peacock already mentioned be effected.

Anything analogous to our "piece moulds" I never saw in Japan, and I was informed that of this method of working nothing was known. The case of "under-cut" work is met by their wax models. Fig. 177 is a cast-iron hibachi with much under-cut work.

In one instance I saw a kettle, the upper half of which was covered with little rounded eminences, closely arranged in geometrical disposition. The mould was, in this case, formed in two parts, an upper and a lower, upon a

wooden core. The upper half of the mould having been separated from the lower, the end of a small iron tool, with rounded point (Fig. 178), was pressed into the sand wherever an eminence was wanted ; and while these indentations of the mould were



FIG. 177.  
CAST-IRON HIBACHI OR FIRE-HOLDER.



FIG. 178.

arranged with almost mathematical accuracy,—row after row being so placed that when the entire half of the mould was covered with these depressions those spiral lines appeared which are always visible when dots are regularly arranged on a globose surface,—yet this work of “pitting” the mould was accomplished simply by eye, and without the aid of any “setting out” whatever.

The casting of kettles is carried on chiefly in the district of Tokio, whence many are taken to Osaka or Kioto to be inlaid with gold and silver, for in no country in the world has damascening been carried to such perfection as in Japan. The finest work of India, Persia, Venice, and the Peninsula being entirely surpassed, both as regards excellence of workmanship and perfection of detail, by many of the Japanese productions. The best of this work occurs where gold is inlaid in certain alloys, and not in iron or steel; but the Japanese inlay in these latter metals also.

The processes employed for the enrichment of metal-work in Japan are more numerous than in any other country, and in the case of small objects metal-work is carried to a perfection unknown to any other people.

Damascening, chasing, hammering, inlaying, and combining metals are means by which they achieve effects, as well as by the careful use of “textures;” but *repoussé* work has been practised in Japan with magnificent results. In bold hammered iron alone, so far as I know, has Japan been beaten by other nations; but while it has produced grand nail-heads (Fig. 36) and good hinges, some of the iron-work Germany wrought during the Middle Ages—like that which may still be seen on the old houses near the cathedral at Frankfort-on-the-Main—is better than any similar work in Japan.

With the exception of the nature of the alloys used, and of the means by which colour is given to metals, the metal manufactures are chiefly carried on in a manner similar to that of other countries.

We here find true damascening. This results from a “dove-tail” cut being made in metal, and by a wire being hammered into this cut. This work is effected in the following way:—

By the aid of a little chisel-like tool (Fig. 179, 1) which is hammered into the metal, a groove is formed with nearly vertical sides. The same tool now tapped with a hammer is run along, first one side of the groove (Fig. 179, 2) and then the other (Fig. 179, 3), so as to make the base of the groove wider than the cut on the surface (Fig. 179, 4). This process always causes the groove to have a raised and slightly recurved edge. This edge is now rubbed down, with

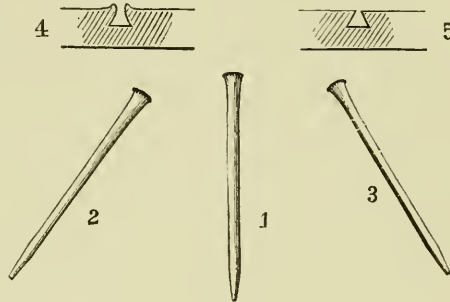

FIG. 179.

the result, as seen from the surface, of making it much narrower than it previously was (Fig. 179, 5). A wire of gold, silver, or some other metal softer than the body in which it is to be inlaid, is hammered into this "dove-tail" groove. The whole is then ground down, and the inlaid wire appears as a gold line on the surface.

By this method most beautiful effects and complicated ornaments are produced; for patterns consisting of straight lines, scroll-work, and even flowers are formed. I have before me, as I write, some specimens of this work which are more minute and beautiful than anything I have seen from any other nation.

The Japanese are also acquainted with the method of producing that elaborate *Kuftgari* work, which is one of the richest of Indian manufactures, and is generally supposed to result from a true method of damascening. But this is not the case, for it is made in the manner in which the Japanese produce their cheaper work, and results from those parts of the surface of the metal, which are to be covered with gold, being made rough by scratching, and by sheet-gold, of the thickness of ordinary writing-paper, being rubbed on to this scratched work, to which it adheres, the rough surface being sufficient to secure its adhesion.

Lines, less in thickness than the shank of an ordinary pin, can

be formed with great accuracy by this method ; and those large masses of gold and of silver which we frequently meet with on Japanese bronzes, and which look like lumps of solid metal, are in reality only pieces of bronze covered with a sheet of gold or silver thus attached.

In Japanese metal-work we not unfrequently find small plaques of enamel introduced. These are first prepared, and then held in their places by the "dove-tail" cut.

Much Japanese metal-work results from the cutting of forms or devices out of a solid lump or plate of metal, which is cut into form after it is fixed in the bronze ; but the choicest effects are due to the absence of all mechanical methods of production, and to the mixture of various metals and alloys in the one work.

I have before me a sort of iron button on which one or two sprays of bamboo have been cut, as well as water with its undulated surface ; but the interest of this little work is greatly increased by the reflected moon appearing in the water ; the moon being formed of a little bit of inlaid silver. Here is another iron button in which a few sprays of some drooping tree have been inlaid in fine gold lines, while under the tree stands on one leg a stork. The stork protrudes from the iron disc (it is in low relief), and has its body formed of silver, while its eye (which is no longer than the eye of a very fine needle) and its legs are of gold. Here is a clasp, two and a half inches long by three-quarters of an inch in width, which has twenty-two little daisy-like flowers formed of white metal with gold centres. The dense mass of little leaves on which these flowers rest is formed of some dark metallic alloy, and each leaf appears to have been chiselled from the solid mass by so many clean cuts. Here is a little chased bead, about half an inch square, ornamented with flowers and an insect ; but interest is imparted to the work by a touch of gold on the insect's neck, and by one flower-bud being in this yellow metal while all else is white. Here is a brooch which has a fruit resembling that of the winter cherry boldly chiselled out of white metal, but through some little openings in the fruit, which represent decay, a red substance appears like coral, while

some of the leaves are white, others black (being formed of an alloy into the composition of which antimony largely enters), and others the rich brown of tea-urn bronze.

Here is a little gourd-like bottle formed of iron, but in this iron are inlaid little curved and irregularly arranged lines of gold. There is no pattern on the object, but the surface is rendered interesting through this curious method of mixing the metals. Here, too, is another gourd-like bottle formed of brass, but with its surface roughened by little irregular rounded lumps of zinc or some similar metal protruding from it.

I have also seen curious convoluted surfaces, formed by a number of thin layers of various metals brazed together till a thick sheet has been formed. Then, by the irregular hammering and bulging of this sheet, and its subsequent grinding down, all the metals of the compound sheet appear on the surface in waved lines.

*Repoussé* work was formerly much practised in the town of Hiroshima (Fig. 180), but the manufacture has been removed to Osaka, where the descendants of the old Hiroshima metal-workers still chiefly live; but *repoussé* work is also made in Kioto and Tokio.

The finest specimens that I have seen of this particular work are the property of Mr. Mounsey.<sup>1</sup> Curiously, I have never seen any other specimens similar to these. He has a bowl in white metal, probably in white copper (called by the Japanese *tutenague*), which has a dragon hammered up on its interior surface with almost inimitable skill. It is one of the finest works in *repoussé* that I have ever seen. Mr. Mounsey has also a pair



FIG. 180.  
BRONZE HIROSHIMA CANDLESTICK.

<sup>1</sup> With much sorrow I learn of this gentleman's death while my book is in the press.

of vases, about two feet in height, surrounded by nimbused saints, and robes treated with a crisp conventionality, equalling, if not surpassing, any mediæval or early renaissance work still preserved to us. There is about these works a "breadth" of treatment, a simplicity of execution, and a boldness of design, which, when mingled with a perfect understanding of the method by which the design has been produced, stamp them as of great excellence.

I cannot but know the "Milton Shield," the other great works of our Elkington, and the products of the atelier of Monsieur Christoffle of Paris, and of Tiffany of New York, as well as the objects preserved in the great museums of Europe; yet, after calm thought, I doubt whether any greater works exist than those of which Mr. Mounsey is the happy possessor. Since I first saw these works I have been told that I have objects of a similar kind, and that I have either had these works of Mr. Mounsey copied, or have succeeded, through seeing them, in possessing myself of like treasures. This is another instance of the fact which so often comes before me, that others know so much more of me than I myself know. Were I speaking according to the best of my knowledge and belief, I should say that the only things of the kind I have ever seen are the magnificent, and perhaps unequalled, works which Mr. Mounsey managed to pick up while in Japan; but as gentlemen have stated that I also have received like works from Japan, I suppose I must be blind, and that they are hidden somewhere amidst my many specimens of oriental art. This I can positively say, that I have never seen them; and that, so far as I know, Mr. Mounsey is the possessor of works in *repoussé* which are both unique and priceless.

I saw the silversmith to the emperor (Mikado) at work on a teapot, hammering up beautiful forms; but what struck me most when in his company was his grand old happy face (he was a very old man) and his spectacles (Fig. 181).

Hiroshima bronze-work attained a celebrity which it richly deserved, and which will increase as time advances. It resulted from the work of the hammer, and from a simple method of inlaying. The vessel itself was of copper-coloured bronze, whether

box, tazza, or tray ; and each specimen bore the marks of the hammer, like a modern frying-pan. Silver inlaid sprays, bordered by sunk tool marks, gave relief to the surface (Fig. 182). But Hiroshima work was also characterised by little embossed metal clasps, which overlaid every crack, handle, or seam in the metal (Fig. 182, *a a*). Hiroshima bronze affords a fine illustration of individuality of work and refined art feeling ; and no better school of hammered bronze exists than that of Hiroshima.

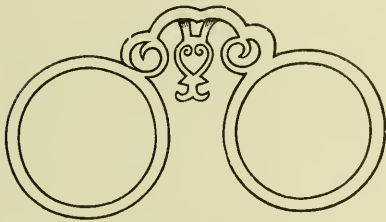

FIG. 181.  
HIS SPECTACLES.

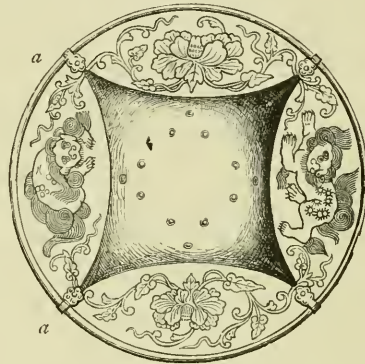

FIG. 182.  
HIROSHIMA BRONZE TAZZA, inlaid with silver.

It would take many printed pages to enumerate the excellences and specialties of Japanese metal-work ; the task, therefore, must not be attempted. The wood-carver, the enameller, the weaver, the printer, and others have an equal demand on my space, which I must divide as well as I can amongst all.

The great charm in Japanese metal work, as in most of their arts, consists in the variety and delicacy, the poetical feeling, and at the same time the boldness, displayed in it. I have here before me a metal netsuki on which I find a butterfly, a moth, a dragon-fly, a gnat, beetles, a bee, grass, leafage, and flowers innumerable. Thus the thought of summer, life, and beauty is conveyed. In an illustration already given, I have spoken of the bamboo drooping over the water in which the moon was reflected, and here the interest centres in the sheen of the reflected orb of night, while the very attitude of the stork, stand-



ing under the golden branches of a weeping tree, removes the netsuki from a mere mechanical work. The bird is obviously thinking ; and even its thoughts can be divined. It is evidently some time since this bird last partook of food, and it has just become conscious of the fact that it will shortly need further sustenance. It stands on one leg, in contemplative mood, meditating on the nature of the meal which it should seek, and for the moment it has scarcely made up its mind which of the finny tribe in the adjacent waters it shall choose for its evening meal.

No people but the Japanese have understood the value of colour in metal compositions. We make steel fenders, copper coal-skuttles, tin kettles, and iron grates ; but we have never fully realised the fact that by producing metallic alloys, and combining these with pure metals, a world of colour is open to us. We have also never known the value of reflected light in relation to metal compositions. If light is reflected from one sheet of copper to another many times it is intense red, if from one plaque of tin to another it becomes an earth-green (*terra vert*), and when all the effects produced by light, reflected by the various metals, is considered, we have open to us an infinite resource of polychromatic harmony.

The Japanese have more nearly achieved the production of colour harmony in metals than any other people ; and in many of their works we see gold, silver, copper, zinc, black-metal, tea-urn bronze, green bronze, and other metals and alloys brought together ; and not only brought together, but so arranged that their colours are brightened by reflected lights, and brought into harmony by skilful juxtaposition.

We are certainly in the very infancy of our knowledge of metal-working. Chilleney's cups are masterpieces of manipulative excellence, and their art qualities are also great ; but there is no colour harmony in anything that Chilleney ever produced. What are gold and silver but vehicles for the production of the beautiful ? and cannot tenderness of shape, delicacy of form, and careful manipulation find expression also in copper, iron, tin, and lead ? Are not these, then, also vehicles for the conveyance of beautiful

thought and refinement of mind? certainly they are; and the Japanese alone, of all civilised nations, understand how to combine metals so that they shall express form, and at the same time combine to produce colour harmonies. In their combination of metals they express an understanding and knowledge of the capabilities of materials greater than that of any European people.

One other point connected with Japanese metal-work is worthy of most careful consideration, namely, the various textures given to metals. We are too fond of bright surfaces, and not unfrequently prefer glitter to repose; but to the Japanese glitter is vulgar. They tell a tale of a servant coming from the rural districts to Tokio, where she entered the service of some distinguished family. In her new abode she discovered a silver teapot, which was beautifully oxydised and subdued in colour, which she at once proceeded to brighten. To the Japanese this tale has a point which is not so striking to us, for to them the whole respectability of the article was removed by this process of polishing, and what was a work worthy of high appreciation had, by her labour, become an object of absolute vulgarity.

I am sure that the Japanese are right in seeking to give to their works in metal such textures as will render their forms apparent, and make the ornaments which they bear prominent by contrast. Many of their works have a "toothed" or gunpowder-like grain, and from this an ornament, having a somewhat smooth surface, frequently stands out. But the number of various textures given to the surfaces of metals by the Japanese is almost endless.

The Japanese are the only perfect metal-workers which the world has yet produced, for they are the only people who do not think of the material, and regard the effect produced as of greater moment than the metal employed. To them iron, zinc, bismuth, gold, silver, and copper, are only so many materials with which things of beauty may be produced, and the one is as acceptable as the other, if perfect appropriateness is seen in the application of the material, and if the result produced be satisfactory and

beautiful. So long as we value the material rather than the art, and insist upon purchasing art objects by the ounce, we can never attain to true knowledge. Whoever heard of music being dealt out in measured quantities. Fancy paying for an oratorio by the length of time taken up in its recital, or purchasing a picture by the yard! Yet if a silver teapot is purchased its weight is demanded, as though the material were not altogether insignificant when compared with the knowledge and skill expended on its production. If a teapot has been formed by a man who has no art knowledge, and who has simply expended upon its production so many hours of labour, then it is right to determine both the value of the labourer's time and the cost of the material; but if the work be beautiful, and if it conveys to the beholder the knowledge and refinement of an educated artist, then it is ridiculous to estimate its value as though the material of which it is composed were of greater worth than the amount of life, thought, and painstaking care expended upon its production.

## CHAPTER VI.

## ON THE MEANS BY WHICH FABRICS RECEIVE PATTERN.

*Processes in which the effect produced results from the use of dyes.*

THE processes of printing on fabrics, and the means by which figures are produced on both cottons and silks, without the aid of the loom, are somewhat various in Japan. With the simple methods of block printing they are perfectly familiar, but of those processes which are mere modifications of our own I need not speak. The methods which I am about to describe are those by which the greater portion of Japanese fabrics receive their figure.

Japanese towels, as I have before said, are strips of a common cloth or calico, about three feet in length by one foot in width, which always bear some simple pattern or curious device, and while they sometimes vary in colour, almost nineteen out of twenty are of blue with a white figure.

All common fabrics, such as towels, coolies' dresses (Fig. 183), etc., seem to be figured by one of the following processes :—

The first method consists in preparing two blocks, the one of which is simply a heavy piece of wood with a perfectly smooth face, while the other has the pattern which is to be given to the cloth cut into its surface,—the pattern is thus wrought in *intaglio* upon it. From the deeper portions of the sunken figures holes are bored through the block to the outer surface, where they are enlarged into funnel-shaped tubes.

In order that the fabric be figured it is stretched over the smooth surface of the plain block, as upon a table; upon this the figured block is now inverted; thus the fabric lies between the

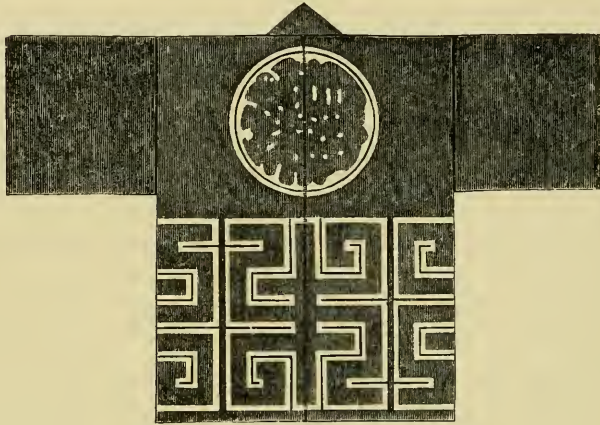

FIG. 183.—PRINTED DRESS OF A COOLIE.  
The circular device is the badge of the master whom he serves.

surfaces of the plain and figured wood. Pressure is now employed so as to bring the surfaces of the blocks as near together as possible, when a dye is poured through the funnel-shaped holes, and is thus brought in contact with the fabric wherever the block has been hollowed. In a few seconds the fabric has become saturated with the dye when the blocks are inverted, all the spare fluid poured off; and thus the fabric has received pattern, for the pressure was sufficient to prevent the "running" of the dye, and thus the obliteration of the figure.

In some cases a dyed fabric receives a white pattern by a modification of this process, in which a weak acid, or some other fluid which will destroy or "discharge" the dye already existing in a dyed cloth, is poured through the holes in the block. It is in this way that many of the towels are figured.

Although I have described this method of producing patterns on cloth it is by no means unknown in our own manufactures; but I believe that it is now almost abandoned in our calico print-works. It being, however, one of the simple processes by which

cottons are figured in Japan, I have thought it desirable to mention it.

Another process by which cotton fabrics receive pattern is that of using a common stencil plate formed of lacquered paper (Fig. 184), but by this simple means two kinds of effect are produced. In the one case the pattern is simply stencilled, a dye being used instead of paint; while in the other case the pattern is stencilled with a kind of paste, or "resist" (a substance that protects cloth from dye when brought in contact with the latter). Whenever the pattern is placed upon the fabric in "resist" the cloth is afterwards immersed in a dye vat, and then washed, by which processes the ground of the cloth first receives colour, and then the "resist" is washed away, leaving a white pattern upon a coloured ground.

There is another modification of this process, by which work is done in the following roundabout manner. Let us suppose that a little figure—say a leaf—has to be distributed in green colour over the surface of a fabric, a thing which could obviously be done by the use of a small stencil plate and a brush with a little green colour. But the Japanese have a labour-expending process (not a labour saving-method) by which they achieve this result. They cut a series of leaves, all of the same shape and size, in paper, and instead of using the sheets from which the leaves have been cut as so many stencil plates, they take these paper leaves themselves and arrange them upon the cloth in the manner required. Now holding a leaf with a finger of the left hand, and with a sort of trowel in the right, on which rests a quantity of resist, they so spread this resist that the leaf is buried, as well as the cloth intervening between the leaves. Leaf after leaf is covered in the same manner, care being taken

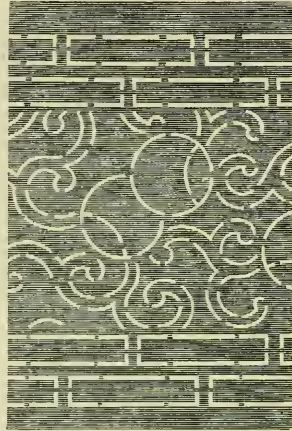

FIG. 184.—STENCIL FORMED OF LACQUERED PAPER. The dark tint shows the paper, and the white lines the openings cut in it, full size.

that the "resist" does not get under the edges of the paper. Each leaf, which is just visible through the "resist" with which the fabric is now covered, is picked up by a needle point; hence at these particular places the fabric is clean. The "resist"



FIG. 185.—PAPER DRAGON.

is now dried, the fabric is dipped in a green dye vat, by which the leaf-like spaces assume their colour. The cloth is now exposed to the steaming process which is so familiar to us, and is then washed; thus the resist is removed, and we have a series of green leaves figuring a white surface. Fig. 185 gives a copy of a dragon cut in paper which I saw used while in Japan in the manner of the leaf just spoken of.

We must now consider the means by which expensive fabrics, such as silks and silk crapes, receive their patterns, but as we have no process in any way analogous to the Japanese method, so far as I am aware, I feel the task of describing it most difficult, and in the whole of these descriptions of processes I have more or less to repeat what I have already said briefly in a paper read some little time since before the Society of Arts; but there I could not go into matters so fully as I can in the present work.

Now as to the means of figuring fabrics, the silk is first given to an artist, who draws the pattern upon it as carefully as if he were designing an historical cartoon. The pieces of silk figured by the process which I am now describing, are about forty feet in length by twelve inches in width, and on the entire fabric the artist places either a varying or a repeating pattern as is required. This pattern he draws with a preparation of indigo, which can readily be removed from the fabric by washing; and he not only gives outline but adds depth, shade, or whatever may enable him to produce a desired effect.

Thus, at the outset, the whole pattern is drawn by hand (Fig.

186), and this we should think a sufficiently costly mode of giving figure to a fabric ; but in the process which we are considering the work is only now in its first stage of production.



FIG. 186.—PAINTING THE DESIGN ON THE FABRIC. After a native drawing.

The artist having finished his work hands the fabric to a workman who has prepared a material of a most tenacious and ductile nature—a sort of glutinous bird-lime. This mucous matter he forms by boiling the finest possible rice-flour with lime water of a particular strength. Having previously prepared this glutinous matter he warms it slightly, and rubs it on a board with a kind of putty knife, but it appears to me as difficult to rub as warm indiarubber would be. A piece of this bird-lime about the size of a small pea is placed on the end of a wooden point or skewer, and a portion of the fabric is stretched flat by bowed pieces of cane being placed beneath it. Thus all is ready for work. Holding the stretched fabric over a small charcoal fire, with the left hand under the cloth, so as to raise any portion of it that may be necessary, and with the point of wood, on which is the little ball of plastic matter, in the other hand, the operator begins by touching the fabric at some point of the pattern, say at the base of a leaf, with the mucous ball, which at once adheres to the cloth. The ball of mucus is now drawn to some little distance from the surface of the fabric, say a foot, but between the fabric and the ball there now intervenes a thread of this mucus, for so ductile is the material, and so sticky, that it will



adhere to anything, and draw out to a thread some yards in length without breaking. By certain dexterous movements of the right hand, in which the wooden point supporting the plastic matter is held, and by the middle finger of the left hand raising the cloth when necessary, a thread of the plastic matter is being constantly formed, and is as constantly dropped upon the fabric as an outline to the pattern (Fig. 187, A). With the utmost skill leaves, flowers,

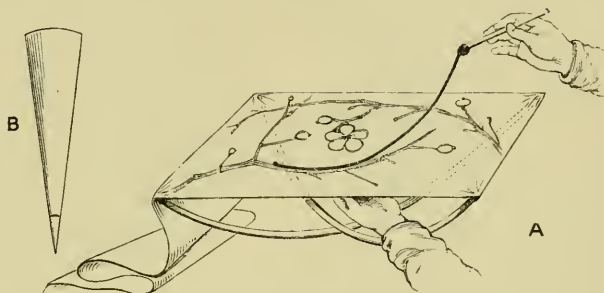

FIG. 187.

and even the small parts of the flowers, as the stamens, are outlined with this mucus, which falls upon the cloth as a thread of about the thickness of an ordinary pin-shank. The whole pattern, however small its detail, or however finely serrated its leaves, is thus outlined. But as this outline is not sufficient, means are adopted for thickening it. Hence a conical tube of oiled paper is formed of about four inches in length, and with an orifice at its broad end of about an inch in diameter. At the small end this tube terminates in a tin nozzle, in the apex of which is an opening such as would be made by a fine darning-needle (Fig. 187, B). This tube is charged with the mucus, and through the fine opening in the tin nozzle the plastic matter is so pressed as to thicken (on the outside) and also to raise the outline already formed. All this has afforded a means of preventing the "running" of dyes which are now to be used; and when thus prepared the fabric is ready for the next stage of the process.

This consists in the painting with dyes of various colours of the spaces enclosed by the little banks of now dry but formerly mucous material; and a care is bestowed upon this painting such as

would suffice for the production of a highly-finished water-colour drawing. In this way the pattern is wrought. The dyes having dried, the colours are exposed for about six minutes to the action of steam in a steam bath (which is a sort of kitchen "steamer" placed over a pot of boiling water), and then the mucous matter is removed by the fabric being gently rinsed in a vat of clean water (Fig. 188).

If the ground is to be coloured the whole of the figures are now painted over by a "resist," and the fabric is then dipped in the dye vat, the ground receiving its colour as it is unprotected.

Landscapes, flowers, birds, and groups of various kinds are produced by this method, and some interesting sketches, which are

often mistaken in England for pure hand drawings, are wrought by this semi-mechanical method.

Many fabrics are made by combinations of these processes ; thus some are in part stencilled and in part wrought by this last mentioned process.

The means of producing an effect just described appears to us the most laborious that could well be imagined ; yet, while the method is laborious, the results achieved are in the highest degree



FIG. 188.—PATTERN OF FABRIC INTO WHICH TELEGRAPH POSTS, WITH THEIR INSULATORS, AND TELEGRAPH WIRES ARE INTRODUCED.

satisfactory, and nothing could be more welcome than some of the effects thus laboriously obtained.

Here, on a length of fabric figured by this strange process, we have a series of panels, some fan-shaped, and some of other strange forms, distributed over the surface. In each of these shapes is painted, with all the tenderness of hand-work, an exquisite group of flowers, a few birds at rest or in flight, or some other pretty objects, while on the ground are dispersed blossoms, sprays, spiders'-webs, and insects in groups of singular interest. No purely mechanical method, such as we employ, could possibly produce the effects gained by this mode of work; and while we may be disposed to talk of "wasted labour" and "laborious methods," the Japanese yet succeed in producing, by their process, effects that all artists esteem; whereas but little work yet achieved by our calico printers has satisfied persons with art knowledge and taste.

The Japanese know other methods of figuring fabrics, as I have already said, but the processes described are those which alone require our notice, for it is these only by which artistic results are achieved; and while we cannot hope that our manufacturers will follow the Japanese methods, we yet commend to their notice the artistic character of the works produced in Japan.

The principal seat of the cotton-printing industry is Nagoya and near towns; but the more expensive fabrics, as silks, are chiefly figured in Kioto.

*On Fabrics figured in the Loom, by Embroidery, and  
by combined Methods.*

As regards the methods by which fabrics receive pattern in the loom little need be said, for they are of primitive character; and the work of the Jacquard apparatus is done by a boy who raises strings and thus enables the weaver to give pattern to his fabrics.

This same method of weaving was formerly employed by us,

for on the top of our loom sat the "draw-boy," whom Jacquard succeeded in dethroning by the ingenious contrivance which bears his name.

In Japan weaving is carried on almost without mechanical appliances, and the shuttle is passed across the warp threads by the hand. Even in those cases where many colours are introduced the various shuttles necessary for the production of the fabric are moved more in the manner of a darning-needle than that in which such a contrivance is moved by us.

For personal wear Japanese fabrics are generally of dark neutral colour, but a girl will show a narrow strip of bright colour around her neck, and the sash which she winds around her waist will often be of rich terry, with a pattern upon it in velvet and gold. But in no case must she wear obtrusive colours, save around the neck, or as a bow on the hair, and even these bits of colour must be small in quantity.

The Japanese seem to understand most of the systems of weaving that we employ, but they also have methods peculiar to themselves. It is common to find terry cloths with parts so cut as to produce a velvet pattern, when the velvet appears as the figure, and the terry as the ground; but when this is the case it generally happens that by looking into the cut surface of the velvet gold may be seen, for the Japanese often weave gold into the substance of a fabric so that it can only be seen through the cut velvet surface.

Speaking of gold, we may here remark that the thread used in the weaving of fabrics for the production of gold tissues is nearly always shredded gilt paper, and that gold thread is scarcely ever used by the Japanese weaver.

The fabrics produced are very varied in character. Some are gorgeous in colour and beautiful in effect; but what these are used for I scarcely know. I have seen bright coloured cloths thrown over trays on which presents were borne to a friend, but in no other way have I seen the gorgeous tissues which they produce utilised. Their houses are not draped; the window openings have no curtains; and there is no furniture to cover.

All I can say is, that during my stay in Japan I never saw, either in the palace of the Mikado, the residence of a minister, the house of a merchant, or the cottage of an artisan, any of their richly coloured fabrics used, either as dress materials or in any other way. On the occasion of a reception given by Sir Harry Parkes one native lady of high rank wore a dress covered with cherry-blossoms of the softest pink shade, and on the robes of the priestesses at Nara were embroidered sprays of somewhat bright colour, and, while neither was of a character similar to the rich specimens of which I possess many examples, they were stronger in colour than anything that I met with in the country, save little bits of common finery in which the children of poor parents were dressed on holiday occasions.

Amidst the rich fabrics we often find specimens in which the ground shades from one colour to another, the most common variation being from red to white. In one illustration I notice that the ground changes about every half yard, whereas in another we have this change occurring about every four inches.

Besides the gorgeous effects produced by polychromatic colouring and the free use of gold, we have many fabrics closely resembling our brocaded silks; and these are either in two distinct colours or are mere damasks, their pattern rendered visible by a certain arrangement of the threads.

Then we have gauze-like tissues of the most charming tints of soft greens, gray-blues, and other neutral colours, with patterns woven upon them in gold, or in gold and colours; but we might almost fancy that the figures on some of these tissues had been produced by darning, for there is no "floating" of the thread at the back of the fabric, and the consequent cutting away of the useless material; and besides these there are scores of other cloths which cannot possibly be described.

Something should be said respecting the character of the patterns with which these fabrics are figured. One consists of a dragon, clouds, and flowers, drawn to a somewhat large scale, and coloured in a rich and neutral manner; some have patterns formed wholly of scroll-work; others have scroll-work grounds

with circular floral ornaments placed upon them. Some have the ground covered with fan-shaped panels, in which landscapes are wrought; and others have patterns of a wholly geometrical character. Then there are patterns formed of clouds, of storks, of insects, of pine leaves, of small diapers, of sailing boats, of bats, of cobwebs, of fungi, of water, of feathers, of fire-flies, of sea-monsters, of broken diapers, irregular powderings, strange key patterns, rosettes; plaids, waved lines, and other elements too numerous to mention, even rain being used in some of their designs.

Out of these strange materials the Japanese artists manage to construct patterns which are both interesting and satisfying, and, discarding symmetry and all other fetters, they give free vent to their fancy and produce designs of the wildest order.

Yet there is nothing *outré* in their patterns, for by flatness of treatment and evenness of distribution they achieve the production of effects having all necessary qualities of repose, although, at the same time they bid defiance to all the canons of European art.

What would an English artist think were he asked to produce a pattern from telegraph posts and wires, or to arrange a design in outline and flat colours which should consist wholly of little boys at play? Yet with such materials the Japanese figure fabrics! Japanese art seems to laugh at the canons by which the European designer is bound, and to hold our method in derision. Clearly, without law and without order, patterns can be constructed which are quite as acceptable as those which other nations with fixed rules have produced.

While speaking thus respecting the art of Japan, I must not be understood to underrate the ornament which arose in Egypt, in China, in Greece, in Byzantium, and in Arabia, and which developed into the styles of Rome, Pompeii, Turkey, Persia, Morocco, and Normandy. Neither do I say that Japanese art is of a more exalted character than these. Its forms are less pure than the Greek, less dignified than those of Egypt, and in it we miss that purity of style which characterises Mahometan orna-

ment. Yet there is a variety and a freshness about it which is unknown to all other systems of decoration; and while it savours little of the college, and makes no pretence to Attic elegance, it is redolent of spring, and has all the freshness of the fields and the flowers.

In the sections Architecture and Art we noticed that much of the interest of Japanese patterns lies in its poetical feeling, and here is a dress which well illustrates this fact (Fig. 189). Woven in Kioto, it was taken to Vienna, where it enjoyed a conspicuous position at the International Exhibition, after which it came into my possession. The pattern of this dress consists of flowers and butterflies drawn in colours upon a cloth of gold ground. The flowers and butterflies are treated as flat ornaments, and are without shade or shadow; but it is not the harmony of colour to which I wish to call attention, perfect as it is, nor the beauty of the drawing,

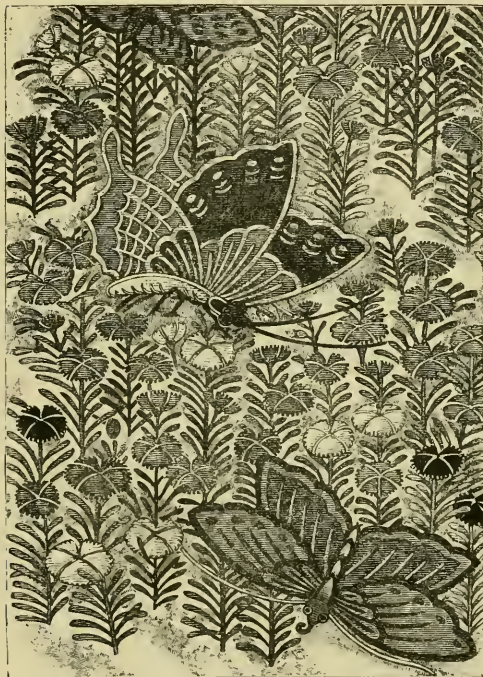

FIG. 189.—WOVEN FABRIC WITH CLOTH OF GOLD GROUND AND FLOWERS AND FLIES IN COLOURS.

though this is excellent, but the thought realised in the work, namely, Summer. No one can look upon this beautiful dress without feeling the influence of the sunny ground, of the profusion of richly coloured bloom, of the glorious insects which appear to hover over the flowers; and the influence makes us feel that it is summer while we gaze. No merely imitative treatment of flowers could possibly convey the thought of summer so well as this

conventional treatment does, and here we are pleased with the consistency of the means employed to achieve the effect, while if the rendering had been naturalistic we should have been offended by inappropriateness.

The richly figured fabrics of Japan are nearly all produced in Kioto, and the majority of the looms are owned by the rich Mitsui banking company, yet private individuals also weave fabrics.

Embroidery is carried on as a manufacture, and it seems never to be practised by ladies as an accomplishment. The fabric to be decorated is stretched on a frame, and men work the pattern much as it is worked in Europe.

Embroidery, as practised in Japan, is of many kinds, but the more usual form is seen on those squares which have been brought into this country in large numbers for banner-screens; yet these do not convey a full idea of the nature of Japanese work.

Two methods of producing results which are peculiar to Japan are these. They have a kind of embroidery consisting wholly of raised dots similar to those often used for the centres of flowers in this country, and which result from wrapping the thread several times round the needle and drawing the latter through the coil. This class of work is made with a fine thread when the work is on a small scale, and with a coarse thread for the production of large pieces, such as we should use for the panels of walls.

The other method is that of forming the ground of a number of spiral arrangements of the thread. It should be noticed that much Japanese embroidery results from stitching threads to the fabric on which the work is placed rather than from stitching through the fabric, as is common with us. When a stout thread is used—say one of the one-sixteenth inch in diameter—and the ground is formed by this cord being rolled into flat spirals of two or more inches in diameter, which are sewn to the fabric, a curious effect is produced; but I have only seen this method of work employed on large pieces. I have also seen the ground formed of gold threads so arranged into masses as to give much



the effect of the ground of "the hawthorn pattern;" and this arrangement has the advantage that, from whatever point of view it may be seen, some parts of the gold will yet be bright.

In some cases remarkable effects are achieved by shaded or mixed yarns being used. In a piece before me as I write I see the silk thread shaded from indigo to claret colour, from claret to green, from green to soft yellow, and from this to light blue, and all the rocks on this piece of work are formed of this mixed yarn. Then we have a sandy beech formed of mixed threads, but here the shades are soft and silvery, and are so managed as to produce a curious sheen. Water is worked in shades of blue, with white crestings to the waves, and the clouds are worked in shades passing from white to red, in various tints of blue, and in a series of amber hues. A figure which is conspicuous in this piece of work has a head and neck formed of a piece of flesh-coloured silk, which is slightly modelled by wool being placed beneath the raised parts. It has eyes formed of talc or horn. The skimp hair of the head, the full eyebrows, the long but sparse moustache and beard, are all formed of the finest of silk, the loose ends of which give a strange naturalistic look to the embroidery. The lips are worked with red, and a soft pink thread gives outline to the features, while the texture of a tiger standing close beside the figure is excellently given by shades of floss silk.

More need not be said respecting embroidery, for we must notice a combination of processes by which the finest effects achieved in Japanese fabrics are rendered.

In England we manufacture printed goods and woven fabrics, and we also work embroidery, but we never attempt to combine the three methods of producing pattern. This is not so with the Japanese, for here we find any methods employed, however varied, in order that effects of an art character be produced. With us, also, printing seems to be employed for the figuring of common stuffs only; but in Japan the methods equivalent to our printing processes are applied to the most costly fabrics, and special attention is paid to the texture of the cloths which are to receive pattern by any method of printing.

Silk crape is a favourite material with the Japanese, and it is often figured by a "resist" being stencilled over parts of the surface, when, by dyeing, a white pattern is produced on a coloured ground, as we have already seen. Such a pattern when occurring on an expensive material is generally enriched by embroidery, some of the flowers being filled in with coloured silks or with gold, while a leaf here and there is emphasised in the same manner.

A dress, which to me is especially beautiful, was woven as a white silk damask, figured all over with the buds and flowers of the plum. So far it is a woven fabric figured in the loom. But now it goes to the printer, and he stencils here and there upon its surface in "resist" fan-shaped panels, and then dips the fabric in a soft scarlet dye. We thus have a scarlet fabric figured with little plum blossoms and white fan-shaped panels.

In each panel are now drawn in tender outline either flowers, fish, animals, birds, or landscape, and the outline is in part filled in with subdued tints of colour. The work next goes to the embroiderer, who works a border around each fan-shaped panel, and who enriches certain portions of the surface with charming sprays of the fir-tree, some in gold, some in yellow-green silk thread, and some in a green shade of indigo (Fig. 190).



FIG. 190.—FABRIC FIGURED IN THE LOOM, AND BY DYEING, PAINTING, AND EMBROIDERY.

This method of combining processes is of the greatest value

in achieving art effects, and we lose more than is generally supposed by our exclusive modes of work. We forget that various processes achieve different results, and that these various effects can be combined in a most welcome and harmonious manner. The question that we have to solve as artists is not simply how we may produce the best effect by printing, by weaving, or by embroidery, but how we can produce the most welcome results by any processes of which we have knowledge. Surely if by a combination of weaving and printing, or of printing and embroidery, or by a union of the three methods of giving figure to cloth, we can get better effects than by employing one method only, it is our duty as well as our privilege to avail ourselves of them.

Nothing can be more stupid than our pig-headed persistence in old methods. Progress is no longer possible if we do only what our forefathers did ; and the gulf which separates one manufacture from another must be crossed if we are to advance as we should. We have yet to learn the need of so using all processes and all materials as to achieve the best possible results. In so doing we may meet with trade opposition and the difficulties which spring from prejudice and ignorance, but these must be encountered and overcome or our manufactures will ultimately be to a great extent replaced by those of Japan.<sup>1</sup>

In some instances embroidery is used to heighten the effect of a drawing, and in the case of Indian ink sketches on silk golden threads are frequently employed to give sheen to clouds. On a specimen of a very beautiful character, in which the drawing is coloured, we have the lustre of ripe capsicums given by threads of floss silk ; and in a melon garden by moonlight we have touches of embroidery which give the idea of the yellow blossoms in a strange and effective manner.

Another method by which fabrics receive pattern in Japan is evidently derived from Central Asia, and practised to this day in

<sup>1</sup> It may here be noticed that Japanese tea-trays have almost entirely superseded our own, and have materially injured our manufacture of such articles, as their price is less than that of English goods, and their art qualities greatly superior.

India ; but the Japanese objects figured by the process about to be described are most frequently silk scarves.

The mode of procedure is as follows. Two pieces of white silk crape are taken, each about three yards in length and twelve inches in width (twelve inches is the usual width of native cloths).

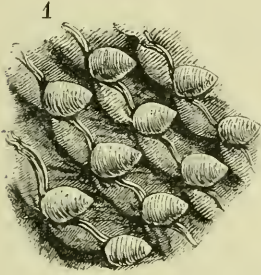

FIG. 191.—FABRIC TIED READY FOR DYEING.



FIG. 192.—FABRIC BEING UNTIED.

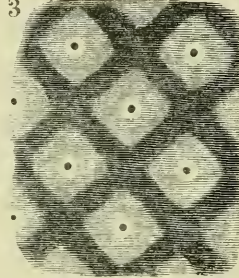

FIG. 193.—FABRIC UNTIED AND STRETCHED FLAT.

These two pieces of fabric are placed together so that one is exactly over the other. Thus placed, we will regard them as forming one double fabric, and will forget that there are two thicknesses, for they are both treated as one, and the two are



FIG. 194.—FINISHED SILK CRAPE FABRIC.

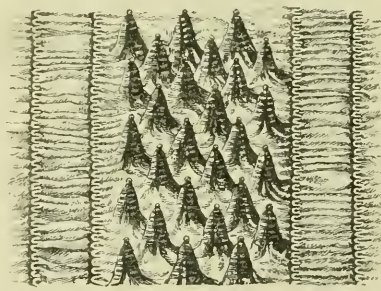

FIG. 195.—PART OF A STRIPED SILK CRAPE FABRIC. The stripes being formed by a method of tying.

manipulated together. A small piece of pointed stick resembling a common meat skewer, and a quantity of waxed thread, are the requisites of the process.

From below a small portion of the fabric is pressed upwards on the point of the skewer into the form of a little cone of, say,

half an inch in height. Around this cone waxed thread is wrapped, so that a little tuft or knot is formed on the surface of the fabric. The skewer is now withdrawn and removed about half an inch from this little tuft, when it is employed to raise a second cone, which in its turn is wrapped round by the waxed thread. This formation of tufts is repeated till the entire fabric is covered with them, when it is ready for dyeing. Thus prepared the fabric is dipped in a dye-vat, which in this case generally contains scarlet or pink colouring matter. The dye gives colour to the cloth, and at the same time shrinks it; hence, where the dye has come in contact with the crape a shrinking has taken place. Thus permanent conical eminences are formed. The waxed thread is now removed, each little tuft being unwound, and not only has a curious fabric been formed with a surface consisting of conical eminences, but also a fabric variegated in colour; for where the wax thread was in contact with the crape the dye could not act upon it; thus by the one operation a fabric has been produced both variegated and with a rich, coarsely-granulated character (Figs. 191, 192, 193, 194, and 195).

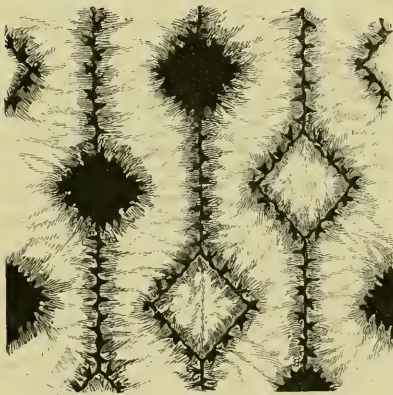

FIG. 196.—COTTON FABRIC FIGURED BY  
TYING AND DYEING.

The height to which these eminences are brought varies much. In some instances conical tufts of half an inch in height completely and regularly cover the fabric, while in other cases the tufts are but small and are arranged into patterns.

Common cotton cloths are also treated in a similar manner, only here the tufts are large; but by the stretching of the fabric after the dyeing is completed irregularly shaped star-like figures have been produced over the surface (Fig. 196).

We must not hope that English manufacturers will adopt a process so laborious as this; yet some of the crape scarves treated

in this manner are amongst the most beautiful and dainty of fabrics. But what the Japanese do by hand we could achieve by the aid of machines ; and it surely would not be very difficult to bind the fabric into tufts by revolving spindles of suitable description.

This interesting manufacture is carried on in two small towns—Narumi and Arimatsu—and the fabrics are called Narumi-shibori (shibori meaning tied or knotted).

## CHAPTER VII.

## MINOR MANUFACTURES OF JAPAN.

IN many manufactures certain printing processes are employed, as in the production of wall-papers, hand-screens, umbrellas, fancy papers, and other things. For whatever purpose printing processes may be employed, the method of engraving and of getting impressions from the blocks seems to be similar.

A drawing is prepared on a thin piece of paper, and this is pasted on a block of cherry wood, which is cut with, and not across, the grain. The engraver cuts through the paper with knives and chisel-like tools. In this way those wooden blocks are prepared which are used for printing the illustrations of books as well as for producing the papers used in the manufactures: The native drawings in this work were engraved in the same manner.

Just as we use several blocks for the production of wall-papers, so the Japanese use various blocks when different colours occur in the one pattern; but their methods of printing are so simple that shading can be effected without difficulty by the use of but one block.

In the production of wall-papers the block is placed face upwards on a table or stool from four to six inches in height, and the block is fed with colour in various ways. Sometimes a brush is used for this purpose, when colours are not unfrequently blended together, so that a polychromatic effect is given by one printing; sometimes by a sort of pad, like that used by engravers for the

production of proof impressions ; and sometimes by a membrane stretched over a circular frame to which a long handle is attached (this feeder closely resembles in form a shallow stew-pan). If fed by either of the latter methods, the colour is first applied to the "dabber," or to the frame, and by these it is given to the block ; but the dabber appears to be chiefly used where colours are shaded from dark towards white. When the block is thus prepared with colour a sheet of paper is placed upon it and pressed in contact with its surface either by the hand or by a pad which is generally formed of a scale from a bamboo shoot as it first issues from the ground.

In no instance where paper is printed did I observe the block brought down on the paper. On the contrary, the paper was always pressed on the block. No printing-press of any description seems ever to have been used in Japan, the simple process already described being that by which all printing is effected.

When speaking of wall-papers, it must be noticed that while these are used on the "slides" which separate the various rooms of a house, they are never produced in continuous rolls, but always in small sheets. Silver is never used in their production, the lustre effect which is so common in them being due to finely powdered mica. The size used for binding the colours is generally a sort of paste made of rice ; but I do not think the use of this material is invariable, for sizes of different sorts, and made from different roots, seem to be used in various cases.

---

Fans are made in many parts of Japan, but the cheaper kinds are produced in the district of Kioto, while the costly productions come chiefly from Tokio. The Japanese claim the folding fan as a native invention, and assert that it was first made in the latter half of the seventh century. They refer its origin to the bat's wing, which was studied as a model. They also assert that it was originally formed of twenty-five flat boards united by strings, and that it was introduced into China from Japan.

The uses of this familiar object are various. It is the house-



hold bellows with which the fire is kindled ; it is the winnowing machine by which the chaff is separated from the rice. Dancing-girls use it in a manner which renders it indispensable as an adjunct to the dance. It is employed by the umpire at wrestling matches as a badge of office ; but the particular form used by this important individual has rather the shape of a Roman paddle than that which we associate with the fan. There is a form of folding fan peculiar to Nara, in which the folds are much broader than the wood side-pieces when the fan is closed ; and in some form or other the fan finds its way into every house. There are perfumed fans, with scented material enclosed between the two thicknesses of paper ; there are waterproof fans, which are used as sprinklers in hot weather by being dipped in water and then swung backwards and forwards in the ordinary way. The Japanese often ask great artists to make a sketch on a fan, great writers to inscribe a few words of poetry, or celebrated men to place their autograph on such an object ; and these they preserve as we do photographs of friends.

Besides the folding fan peculiar to Nara, there are hand screens, or flat fans, made in this town which we do not find in any other part of the country. These are sometimes formed of silk and sometimes of paper, but in all cases they are perforated like our stencil plates, only the perforations are exceedingly fine. Sometimes the pattern consists of diaper-work or small geometrical figures, and at other times of flowers, animals, or birds ; but in all cases the figure is produced by perforation.

These fans are always made by hand ; but if formed of paper six thicknesses are cut through at the same time, while if silk is used a smaller number of thicknesses are brought together during the operation of cutting. The accuracy with which this perforating is accomplished, and the minuteness of the work, causes us to wonder at the skill of the workmen, for lines no thicker than the shank of a medium-sized pin are commonly cut, not only in paper but also in silk.

When these pieces are made into screens one piece is pasted on the front and another on the back, but they are so arranged

that the perforations of one fit exactly over the perforations of the other.

---

There is in Japan a material which we call crape-paper, as it closely resembles the crimped woven fabric which we know as crape. This is a tough, fibrous paper to which a crape-like surface has been given ; but the process of manufacture I did not see during my stay in the country. I am therefore compelled to give the description of the process which appeared in the Japanese catalogue of the Philadelphian Exhibition :—

“The crape paper, which is a most perfect imitation of the real crape, is made by a very ingenious and most simple process. In the first place, that which may be called the matrix-paper is prepared by laying a moistened sheet of strong paper on a wooden board cut with fine grooves running either parallel or crossing one another at very small angles, and by beating it with hard brushes so as to force it into these grooves. It is then painted over with the frequently mentioned ‘shibu,’ in consequence of which operation the paper becomes so elastic that when let go after having been stretched out it refolds by itself. For the production of crape several sheets of thin moistened paper are laid alternately with sheets of the above-mentioned matrix-paper, one upon the other. The package is then wound on to a round piece of wood, and pressed several times with a strong lever, as if it were to be stripped off from this piece of wood. By means of this operation the soft and moistened paper is forced into the folds of the matrix, and consequently folded in a similar manner. By repeating this manipulation ten or twelve times, each time unrolling it in order to change the position of the paper between the sheets of matrix-paper, and by winding it again on the piece of wood, the paper becomes gradually folded in all directions, the intersecting points of all these folds producing the craped surface. Naturally, this process causes the paper to shrink considerably. This kind of craping is done with printed pictures, and also with coloured papers, which are used for coiffures.”

Paper leathers also receive their textures in a like way, and in the last Paris Exhibition some pieces with the coarsest of “grain” were shown. The patterns which are embossed upon these leather-like surfaces are almost always due to the fabric being hammered with hard brushes upon a matrix in much the same manner as we form the moulds in the process by which our newspapers are stereotyped.

---

- With regard to baskets there is nothing of importance to be noticed, except the fact that in a large number of cases they are formed from flat sheets of plaited work which are cut into shape and joined together.

When thus made the basket is generally lined with a kind of plaited work differing from that of the exterior, and the seams are covered by strips of bamboo sewn over in basket-like fashion.

The plaited work of which the exterior of the basket is made is formed of shreds of the bamboo, on one side of which is that hard glossy surface characteristic of the stem of the plant, and these sheets are plaited much in the manner of our cane bottoms for chairs. All good baskets have as their exterior this glabrous surface, which possesses the quality of resisting dirt to a remarkable degree. The inner lining of the basket is formed of flat laths of extreme thinness, which are cut from that portion of the bamboo which remains after the silicious surface has been removed. Common baskets, used for holding eggs and other household purposes, are made of the inner portions of the stem, like the lining of the better works.

Baskets are also made in Japan from the shoots of the *Westeria* creeper, but these are not in general use, and there is no special interest attaching to them. Occasionally a beautiful basket may be seen formed of fine string of some kind instead of bamboo. Such a basket, rubbed over with brown lacquer and dusted with gold, is before me as I write. We have already seen that beautiful works are also formed of fern fronds (see page 194).

The Japanese are the best basket-makers in the world, and they alone have raised the manufacture to an art industry. They make baskets which are not only useful but beautiful, and many of them must be classed as true art objects. Their forms are carefully considered, the patterns into which the bamboo is worked are beautiful, the contrast of open work with solid is duly appreciated, and the handle is often of most dainty character, while its curve almost invariably forms a pleasant contrast with the lines of the other parts of the work. As I write I have by my side a number of baskets from Japan, China, Formosa, India, Jamaica,

Ceylon, Java, Haiti, Spain, and Algeria, but none of them are comparable as works of art with those from Japan.

Boxes are also made of fine basket-work on which lacquer sprays are sometimes drawn, the interstices between the strips of bamboo being filled up so that a level surface is produced where the flower is to be drawn. Cabinets, luncheon baskets, and other things are in some cases covered with plaited bamboo-work, and we are all familiar with the egg-shell sachi cups covered with basket-work. Sachi bottles similarly covered are common. Immense bags, many feet in length, are also formed of strips of bamboo; these are filled with boulder-stones and then arranged in piles as an embankment to a river, as we have already seen; and little nets are formed from strips of bamboo for carrying oranges and other fruits.

---

The Japanese differ from all other people in the extended use of material, and in the mingling of a number of substances in the one object. The advantages which accrue from this use of varied materials, and from the mingling of different substances in the one object, is greater than we might at first suppose.

In the sections on the metal manufactures the fact was noted that the Japanese use metals for their art qualities, and to a great extent disregard their intrinsic worth. It is so with other materials also, for an art workman in Japan seems to search the earth and the seas for material with which to produce beautiful objects.

A pipe-case which I have just been inspecting is formed of ivory, and it is decorated with inlaid sprays of bamboo and birds; but its interest rests in the fact that colour is given to the sprays by the use of different kinds of material. Thus we have leaves formed of tortoise-shell, of pearl, of gold, of oxydised silver, and of ivory dyed green, while the birds are formed of horn, through which coloured pigments are just visible. But each bird has a golden eye.

By employing this variety of material richness of effect is got, and colour is also secured; whereas we to a great extent lose the advantages of colour through confining ourselves to certain kinds

of materials. Fig. 197 gives a wood pipe-case in which flowers and butterflies formed of various metals are inlaid.



FIG. 197.—PIPE-CASE, formed of wood, with pattern of chased inlaid metals—gold, silver, and bronze being used in the work.

But besides combining various substances in the one object the Japanese use materials which no other people employ in their manufactures.

Bark is worked into trays of considerable beauty, which are either left plain or lacquered. And bark is largely used as a veneer, the trays being made in Nikkô and the veneer work done chiefly in the district of Hakoné.

The bark used as a veneer is of various kinds, but that most generally employed is of ash-gray colour, with a rough and somewhat suberous character. That employed for the manufacture of the Nikkô trays is comparatively smooth and ligneous, and appears to be the inner bark of a cone-bearing tree. The inner layers of a certain kind of fibrous bark are also used for the thatch of temples; and a roof of this material which has become celebrated in Japan owing to the perfection of its workmanship and the time during which it has lasted, is pointed out as one of the sights of Nara.

In Japan I purchased a set of sachi cups made of orange-peel. The rind of half an orange had been shaped into a beautiful form, dried, and covered with a thin coating of transparent lacquer. Internally the cup was covered with red lacquer of perfect finish.

These little cups were not mere ornaments; they were dainty little vessels from which the Japanese would sip their sachi, as we should wine from a Venetian glass. And they would certainly prove durable. But I suppose that the British workman would as soon think of making his breakfast of cowhides as he would of making orange-peel into cups.

I found in Tokio a manufacture which concerned itself with the working of sea-weed into pocket-books, plaited hats, and other things. The form of algæ used was evidently a tangle. By some

means the salt was extracted from it, and it was rendered pliable while the beautiful smoothness of its surface was retained.

The town of Okabe in Suruga is almost entirely devoted to the manufacture of mats, trays, and chop-sticks, from the stems of the common brake fern. Mats are made by a number of stems of equal size being arranged in parallel rows and held together by long copper pins which run crosswise through the stems, or by being first pinned and then plaited together by a little thread of cane. The trays are formed in the same manner, only they are margined by one or two stems similar to those of which the bottom part is made. The margin is generally tied to the bottom part at two or three points by strips of cherry bark (Fig. 63).

At Yumoto-kawabata, in the province of Sagami, baskets, which are beautiful in shape, and hats of helmet-like form, are made from the fronds of a pinnate fern which are most ingeniously plaited together. The pieces of frond used for this purpose are generally about twelve or fifteen inches in length, and the pinnæ extend to about six inches on either side of the mid-rib. When dried this frond is smooth, of soft buff colour, and leathery consistency; but before being plaited the mid-rib is pared to about one-third of its original consistency (Fig. 64).

The rind of the gourd is also used in Japan, and with it cups, ladles, and even teapots are made. A bottle gourd which is sawn in two lengthwise makes two excellent ladles when their interiors are well lacquered; but the use of the gourd, save as the pilgrim bottle, is not general in Japan.

I have seen excellent stands, with lacquered and inlaid ornaments upon them, formed of those fungoid masses which we sometimes see protruding from the sides of trees. And I have seen a box formed of a sea-urchin (*Echinus*) shell, with lacquered interior.

When the bamboo first rises from the ground the stem is almost enveloped in large scale-like leaves like a colossal asparagus shoot. These are shed when the foliaceous branches make their appearance. Such scales are somewhat scoop-shaped, as they more or less encircle the stem. They are gray in colour, fibrous, and slightly striated in character owing to their endogenous forma-

tion. These scales are used as veneer to much of the work now made at Tajima ; but in this case they are most commonly cut into little squares so arranged that the fibres of the scale run vertically and horizontally in the alternate squares.

Flattened grass stems are also largely used for the covering of wooden boxes ; and when dyed into many colours beautiful objects are made with this simple material : Bamboo scales are sometimes, though not frequently, covered with lacquer and used as scoops.

I have mentioned a number of materials used by the Japanese in order to show English manufacturers that they do not avail themselves of many materials capable of being formed into beautiful objects ; but I have not even named the two which furnish more of the useful objects of Japan than any other, scarcely excepting clay itself. These are the bamboo and paper.

To enumerate the various uses to which the bamboo is put would be to furnish a list altogether unreadable, for they seem to make everything of bamboo, and to treat it in every imaginable manner.

It must be remembered that the bamboo is a tough, fibrous, giant grass, with hollow stem divided horizontally at the knots. Thus it consists of a series of cylindrical chambers superposed one on the other, and separated from each other by horizontal wooden divisions—the knots or divisions being very close to each other near the root of the plant, and removed from each other by a considerable distance in the higher part of the stem. It is from these knots that the thin shoots on which the foliage is borne are protruded.

Before me, as I write, are a series of carved boxes each made from a section of the stem with two of the transverse divisions, the one forming the top and the other the bottom of the box ; and these boxes vary in height according as the joint has come from the centre or lower portion of the stem. Here is a sachi bottle formed of an elongated joint, and with an arched handle. On it is a beautiful spray of the magnolia carved in the manner called *cameo*, and with a bud so arranged as to become the spout from which the sachi is poured. A plugged hole at the top permits of the

vessel being filled with the exhilarating fluid (Fig. 198). Here is a spill bordered with a Greek key pattern, and on one side of which a snake is carved, while on the other we have a flower, the surface being lowered in both cases so that the figure stands



FIG. 198.—SACHI BOTTLE, formed of a portion of a bamboo stem, with two horizontal septa—one becoming the top, the other the bottom, of the vessel.

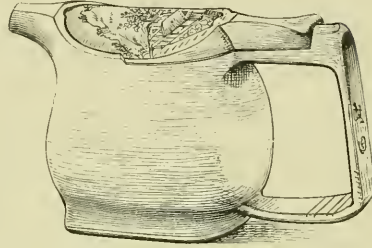

FIG. 199.—TEAPOT, formed of portion of bamboo stem, with three septa.

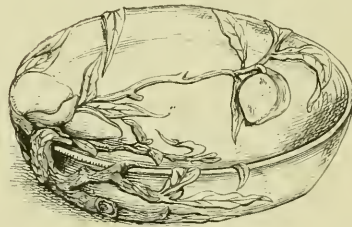

FIG. 200.—TRAY, formed of the carved transverse partition of a bamboo stem (*the dissepiment*).

out in relief. But besides the carving, this beautiful spill is enriched with a little lacquer-work, in which gold, oxydised silver, and a warm brown colour, prevail. Here is another spill with flowers cut upon it in *intaglio*. Here is a tea-box or tea-caddy formed out of a short root joint. Here is a teapot also formed of a root joint, with the spout carved in the thickness of the side. A hole is made in the top, to which a lid is fitted, and the handle consists of a tuft of lateral shoots. Here is another made out of two cells and three of the dissepiments, the one being utilised as the handle (Fig. 199). But before me I see scoops made of portions of the stem, trays formed of the horizontal divisions, both carved (Fig. 200) and plain; medicine boxes; portable writing-cases;



a box formed by splitting a portion of the stem lengthwise; a nest of boxes, consisting of a number of superposed joints; a censer in the form of a tripod; and many other things. But the Japanese attach handles to portions of the stem and thus make useful ladles. They use large joints for the carrying of water as we use pails. They make fences of a hundred different kinds by plaiting and intertwining the thin shoots in various ways (Figs. 1 to 15). They make sun blinds by threading little bits of bamboo on strings, as we thread beads; they split it into laths and form mats by attaching the strips together with threads; they make the spokes of their fans of bamboo. They split a stem throughout a portion of its length and make a hand screen by spreading the split portions and pasting paper over them. They make their fishing-rods of the bamboo; they convey water in bamboo stems from which the transverse members or dissepiments have been removed; and the gutters around their houses are formed of this material. Their baskets are of the bamboo (willow is not used in Japan for basket-work); and, by hammering it till it is reduced to a broken and fibrous condition, they form a fuse used for blasting operations; while the tooth-brush is a bit of bamboo stem, with the end rendered fibrous by hammering. These are some of the uses to which the bamboo is put in Japan, but they are only a few out of a multitude.

The Japanese paper is tough and fibrous, and we have seen that they treat it in various ways so as to give to it the appearance of other substances. Thus they make from it a material closely resembling leather, and also an imitation of tortoise-shell so like the substance imitated that it might readily be taken for the real shell. They make a paper so gossamer-like that the air passes through it as it would through a net, and which might almost be used for ladies' veils.

In its leather-like form paper is used for the making of pocket-books, tobacco-pouches, pipe-cases, satchels, and for most of the purposes to which we should apply leather. In the form of imitation tortoise-shell it is inlaid into cabinets and trays. Japanese pocket-handkerchiefs are formed of paper, and some of these may

be rubbed up into a ball without their tearing, when they become as soft as the finest cambric. Small parcels are almost invariably tied with string formed of twisted paper. Waterproof coats are formed of paper, as well as the "aprons" of the jinrikishas, and paper is also put to all those uses to which we apply it in England.

---

I have now, so far as I could, described the arts and the art industries of Japan, but want of space has compelled me to treat some of the subjects imperfectly. The art of Japan is so full of interest that a large volume and many illustrations should be devoted to it alone; and especially should coloured illustrations be employed if justice is to be done to it. The manufacturing processes are so varied and so interesting that a volume should be devoted to their consideration also. My book may, however, awaken some interest in the beautiful works which Japan produces, and throw some little light on the architecture, the art, and the manufactures of the country. It may also lead to improvement in our own manufactures by calling attention to excellences in the productions of others. If it should achieve these results, or any of them, I shall feel that my labour has been well bestowed.

Some interesting manufactures I have been unable to describe for want of sufficient knowledge; and one of the most interesting, *i.e.* the manufacture of *cloisonné* enamel-work on porcelain, I have been obliged to pass unnoticed. While in Japan I observed every detail of the process, and after I left the country Dr. Roritz, of Nagoya, most kindly got for me a specimen of every process in the manufacture, and samples of all the substances used. These were sent to the care of a London trading firm, which appears to have sold them in mistake for their own goods. But, unfortunately, the collection was sold in parts, and no one got a complete set of specimens. To me they were all lost, and I had no opportunity of analysing the substances used in the process. The wires are attached to a biscuit-ware and not to a glazed surface, and to this they are stuck by a gum-like substance (probably a liquid resin or a solid volatile oil). When all

the wires have been fixed in their places, the whole work—wires and biscuit—are smothered in a white semi-fluid matter. The object is now dried, and sent to an oven, where the white matter with which it has been covered becomes vitrified. But this substance never actually melts. It has no tendency to run, but simply becomes hard and gritty; is it borax? It is this substance which fixes the wires in their places, and the whole secret of the manufacture rests here. After the wires are thus fixed the soft enamel colours are placed in the cells and are vitrified; and this process of filling and of vitrifying is repeated so that the cells become filled with a true enamel. The work is now ground down till it is smooth, and the outer edges of the wires are all distinct; then comes a polishing process, after which the work is finished. In all respects this manufacture resembles that of *cloisonné* metal objects, save in the fixing of the wires to earth instead of soldering them to metal, and the manufacture of the metal *cloisonné* is now so familiar as to require no description.

The whole of the manufacturing processes of Japan are conducted without the aid of any mechanical contrivances whatever, and with the simplest of tools. I do not think that the country boasts a saw of sufficient length to cut through a large log of wood. The saw has the form of a butcher's chopper, and when it has cut well into the angle at the end of a log, the log is turned, and work is begun on the opposite side. By repeated turnings a plank is cut. The plane cuts pulling towards the workman, and so does the saw. I never saw a lathe with a continuous rotary motion, save in the Royal Arsenal, which is nothing more than a European workshop; and I never but once saw a labour-saving contrivance of any kind in the country. Rice is husked by being placed in a sort of mortar into which a pestle falls. The pestle is attached to a horizontal piece of wood supported by a fulcrum in the centre. On the end opposite to the pestle a man stands; thus the pestle is raised: but by his jumping off the pestle falls. By this repeated stepping on the end and jumping off the process of husking the rice is accomplished.

In the corner of a field I once saw one of these mills with a

kind of bucket placed on the end of the beam where the man would stand. A small water-spout coming from a hillside filled this bucket with water, when it raised the pestle. But the

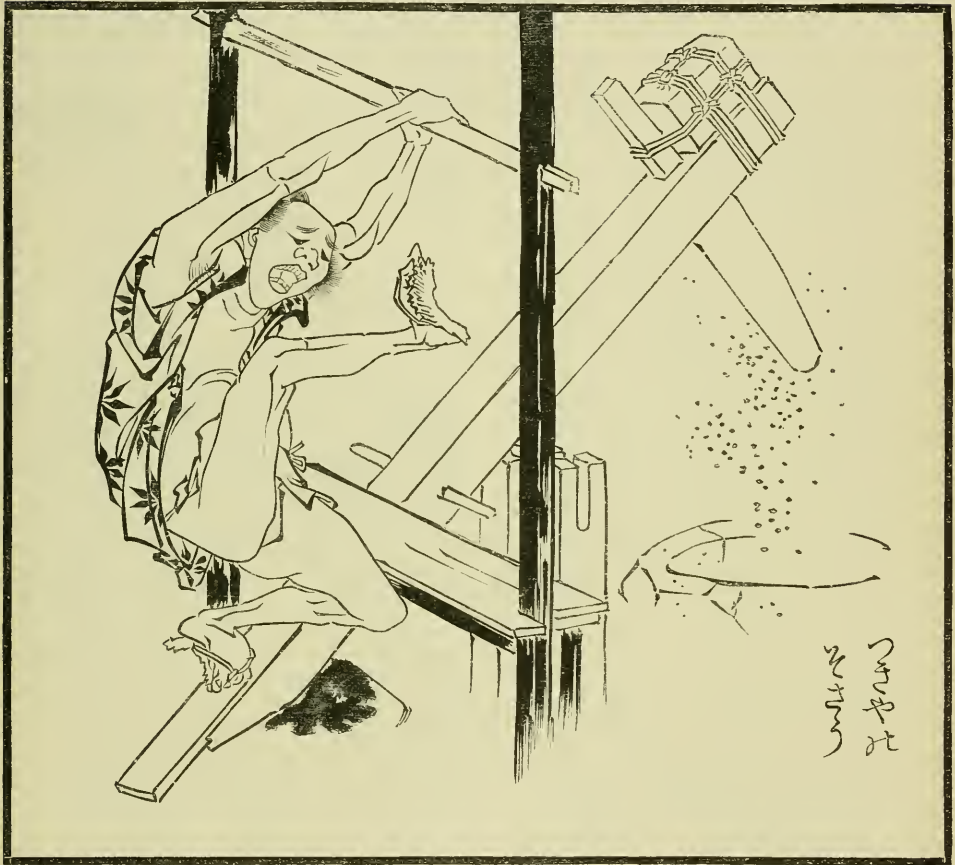

FIG. 201.—HUMOROUS SKETCH OF A MAN WORKING A RICE MILL, WHO BY HIS ENERGY HAS JERKED THE FULCRUM FROM ITS SOCKET.

act of raising upset the water, and thus let the pestle fall. A humorous native sketch of an energetic workman, who by his exuberant energy has displaced the beam, is given in Fig. 201; and the delighted man who has found out the labour-saving contrivance is given, together with his mill, in Fig. 202.<sup>1</sup> This, as I

<sup>1</sup> A similar contrivance is still in use in the north of England.

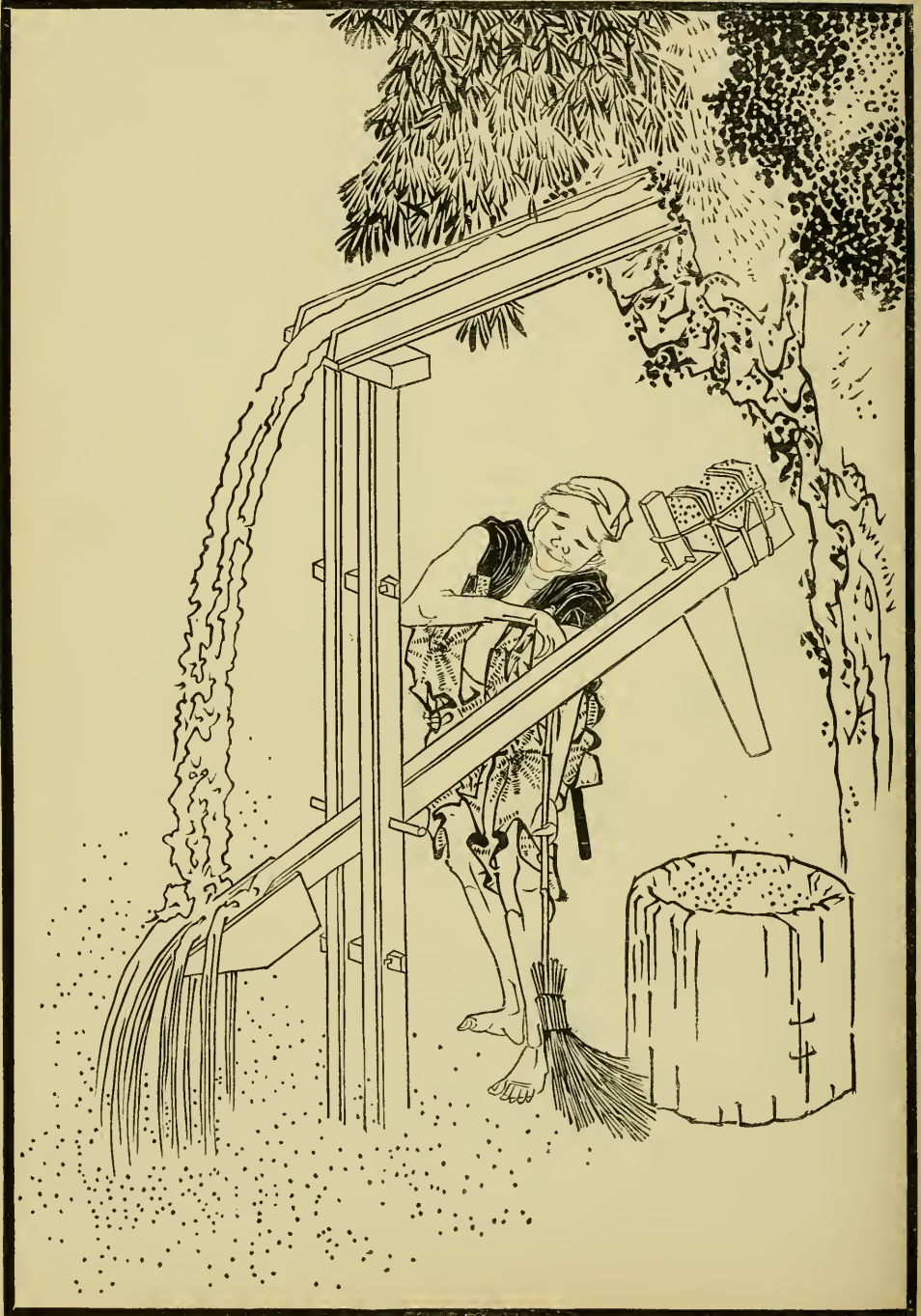

FIG. 202.—RICE MILL WORKED BY WATER POWER.

have just said, is the only machine that I ever saw in Japan, yet the productions of the country would lead us to infer that machinery of an advanced character must be common. Various forms of water-wheels are known, but during all my travels I never saw one.

The following may be useful, as it is a list of the chief woods of the country, with the Japanese, the English, and the botanical name of each, the natural order to which the tree belongs, and the chief uses to which each is put, as prepared by Motoyoshi Ono of Tokio for the instruction of engineers, students, and merchants.

- Ho-no-ki. Magnolia. *Magnolia hypoleuca* S. et Z. Magnoliaceæ. Used for sword scabbards and cabinet-work.
- Katsura. Cercidiphyllum. *Cercidiphyllum Japonicum* S. et Z. Magnoliaceæ. Used for furniture and boxes.
- Mokkoku. Ternstroemia. *Ternstroemia Japonica* Th. Ternstroemiaceæ. Used for joinery.
- Kiwada. Phellodendron. *Phellodendron amurense* Rupr. Xanthoxylaceæ. Used for joinery.
- Kenpo-nashi. Sweet hovenia. *Hovenia dulcis* Th. Rhamnaceæ. Used for joinery.
- To-chi-no-ki. Horse-chestnut-tree. *Æsculus turbinata* Bl. Sapindaceæ. Used for joinery.
- Urushi. Lacquer-tree. *Rhus vernicifera* Dc. Anacardiaceæ. Used for boxes and joinery.
- Yenju. Sophora. *Sophora Japonica* L. Leguminosæ. Used for joinery.
- Sakura. Cherry wood. *Prunus pseudocerasus* Lind. Rosaceæ. Used for woodcuts and joinery.
- Kaki. Persimmon wood. *Diospyros kaki* L. Ebenaceæ. Used for joinery.
- Kuro-gaki. Black persimmon. *Diospyros kaki* L. Ebenaceæ. Used for joinery.
- Yego-no-ki. Styraç. *Styrax Japonicum* S. et Z. Styracaceæ. Used for joinery and turnery.
- Shoji. Kind of ash-tree. *Fraxinus*. Oleaceæ. Used for joinery.
- Kiri. Paulownia. *Paulownia imperialis* S. et Z. Scrophulariaceæ. Used for boxes and furniture.
- Kusu. Camphor. *Cinnamomum camphora* F. Nees. et Ebern. Lauraceæ. Used for joinery.
- Yama-giri. Wood oil-tree. *Elæococca cordata* Bl. Euphorbiaceæ. Used for joinery.

- Keyaki. Zelkova (planera). *Zelkova Keaki Sieb.* Urticaceæ. Used for timber, joinery, furniture, etc.
- Muku-ye-no-ki. Aphananthe. *Aphananthe aspera Pl.* Urticaceæ. Used for joinery.
- Kuwa. White mulberry. *Morus alba L.* Urticaceæ. Used for joinery and furniture.
- Nara. Kind of oak. *Quercus crispula Bl.* Amentiferæ. Used for handles, ships, and timber.
- Shihi-no-ki. Kind of oak. *Quercus cuspidata Th.* Amentiferæ. Used for handles, ships, and timber.
- Shira-gashi. Kind of oak. *Quercus thalassica Hance.* Amentiferæ. Used for handles, ships, and timber.
- Aka-gashi. Kind of oak. *Quercus acuta Th.* Amentiferæ. Used for handles, ships, and timber.
- Sawaguri. Kind of oak. *Quercus sp.* Amentiferæ. Used for handles, ships, and timber.
- Kuri. Chestnut-tree. *Castanea vulgaris Lamk.* Amentiferæ. Used for boxes, joinery, furniture, and timber.
- O-matsu. Black pine. *Pinus Thunbergii Parlat.* Coniferæ. Used for timber.
- Me-matsu. Red pine. *Pinus densiflora S. et Z.* Coniferæ. Used for timber.
- Hime-ko-matsu. Yellow pine. *Pinus parviflora S. et Z.* Coniferæ. Used for joinery and timber.
- Kara-matsu. Larch-tree. *Larix leptolepis Gord.* Coniferæ. Used for timber.
- Momi. Fir (Coarse texture). *Abies firma S. et Z.* Coniferæ. Used for timber and boxes.
- Shirabe. Fir (fine texture). *Abies menziesii S. et Z.* Coniferæ. Used for boxes and timber.
- Tohi. Fir (white wood). *Abies alcockiana Lindl.* Coniferæ. Used for boxes and timber.
- Tsuga. Fir. *Abies Tsuga S. et Z.* Coniferæ. Used for timber.
- Sugi. Japanese cedar. *Cryptomeria japonica Don.* Coniferæ. Used for timber and cooper's work.
- Kurobe-sugi. Japanese cedar. *Cryptomeria japonica Don.* Coniferæ. Used for timber and cooper's work.
- Hiba. Thujopsis. *Thujopsis dolabrata S. et Z.* Coniferæ. Used for timber (much valued).
- Nedzuko. Selaginellense Thujopsis. *Thujopsis latevirens Lind.* Coniferæ. Used for timber.
- Sawara. Kind of white cedar. *Chamaeyaris pisifera S. et Z.* Coniferæ. Used for timber and cooper's work.

- Hi-no-ki. Kind of white cedar. *Chamaecyparis obtusa* S. et Z. Coniferæ.  
Used for timber (much valued).
- Beni-byakusin. Juniperus. *Juniperus nipponica* Maxm. Coniferæ.  
Used for joinery and timber.
- Wa-byakudan. Arbor vitæ. *Thuja*. Coniferæ. Used for joinery.
- Araragi. Yew-tree. *Taxus cuspidata* S. et Z. Coniferæ. Used for  
joinery.
- Kaya. Nut-bearing tree resembling the yew-tree. *Torreya nucifera* Z. et S.  
Used for boxes and fine timber.
- Icho. Ginko tree. *Ginkgo biloba* S. et Z. Coniferæ. Used for boxes and  
chessboards.

THE END.











BOSTON PUBLIC LIBRARY



3 9999 05692 2899



