

The
BLACK SEALS
of
SOLOMON
THE KING

Carl Nagel

The Double Seal of Solomon

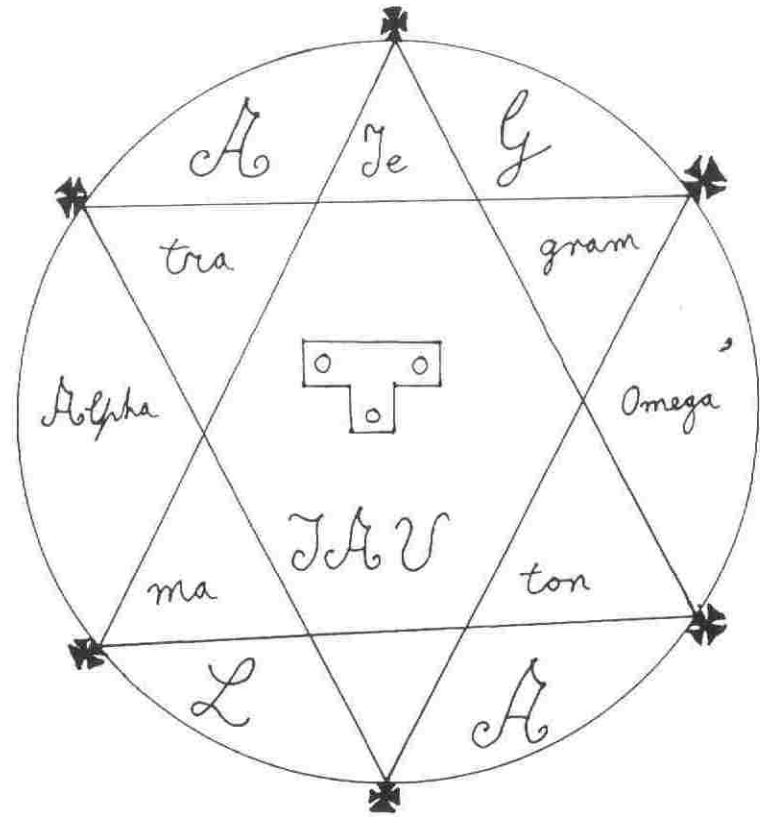

Figure 1-1

THEORY

The theory of the present study is based on the idea that the use of a computer program can help to reduce the time and effort required to learn a new language. The program is designed to provide a structured and interactive learning environment that allows the user to practice their skills and receive immediate feedback.



Figure 1: A person using a computer program.

CONCLUSION

The results of the study show that the use of a computer program can significantly improve the learning of a new language. The program provides a structured and interactive learning environment that allows the user to practice their skills and receive immediate feedback. The results also show that the program is easy to use and can be used by people of all ages and backgrounds. The program is a valuable tool for anyone who wants to learn a new language.

REFERENCES

- 1. Smith, J. (2010). The effectiveness of computer-based language learning programs. *Journal of Educational Technology*, 12(3), 45-58.
- 2. Brown, S. (2008). The impact of technology on language learning. *Language Learning*, 58(2), 215-230.
- 3. Johnson, K. (2005). The use of computers in language learning. *Computer Assisted Language Learning*, 18(1), 1-15.

his beloved children during the courses of their very mortal lives, all you as an individual have to do is diligently follow the easy-to-understand instructions given in the following pages of the book on how to both charge and employ the Black Seal or Seals of your choice.

The Black Seals, as does the Double Seal of Solomon (Figure 1-1), originate from the pages of various magickal textbooks from the Middle Ages.

With a little bit of luck, you should be able to discover somewhere within the pages of this magickal textbook, an appropriate Black Seal with which your own particular problem or problems can be solved with the help of the magickal forces attracted to the chosen seal.

“Must I” you might ask, “be an experienced occultist or Black Magician before I can succeed in producing the desired results through the implementation of the Magickal Power of the Black Seals as described in this book?” Obviously, any form of experience in the field of occultism in general and so-called Black Magick in particular can be of great help in using the Black Seals; but, having said that, let me say this: no such prior experience is required, as evocation of the seventy-two spirits of the brass vessel is an art and a science you can easily master. Neither should you possess any undue fear as regards using a Black Seal as described in succeeding sections of this book. Although we are in fact dealing with the powers and offices ascribed to certain infernal spirits – let me assure you that these forces are far more ‘human’ in their nature and in their relationship to mankind as a whole than angels could ever hope to be.

WHAT DEMONS REALLY ARE

Demons and evil spirits are the personifications of the three most basic and all-consuming desires within us all: greed, lust, and revenge. What, therefore, could be safer than dealing with your own self?

Rest assured that, providing you have taken adequate safety measures prior to the commencement of the appropriate Rite of Evocation, nothing in the least untoward will happen to you; on the contrary, you should have found a magickal way to improve your business, social and personal affairs whenever and wherever that help is needed.

HOW TO INCREASE THE MAGICKAL POWER OF THE SEVENTY-TWO BLACK SEALS

After selecting the appropriate Black Seal and imbuing it with the power and majesty of the spirit (see Part Three), there are some simple means by which an individual may help to increase the chosen Seal’s latent and ancient powers one is using to produce results in line with the original intent.

These methods are as follows:

- (A) Do not ask for the impossible. Chasing castles in the sky will get you nowhere fast. Real magick comes from within; the spirits and forces as evoked in Ritual and Ceremonial Magick are simply a means to an end, so you must firmly believe that what you seek is realistic, believable as regard your present financial and emotional position in life and is within the realms of probability.
- (B) Do not doubt, for a single moment, the Seal’s power to reproduce your desires in a tangible and solid manner. There really is the possibility of the forces you have evoked turning on you if you show doubt in their abilities. So please, show them nothing but respect. You’ve been warned.
- (C) Be constantly aware of why you created the Black Seal and that its latent magick power force is working twenty-four hours of each day to bring your desire into glorious and everlasting reality. This, above all else, can help to increase self-confidence and, by doing so, remove any lingering mental slivers of destructive doubt.
- (D) Keep the fact that you are using magick, particularly this form of magick, a closely guarded secret from the less enlightened members of your community. Telling others of your actions will only lead to derogatory comments, and humiliation at the hands of ‘well meaning’ church-goers. Keep your own mouth shut.

By faithfully following those four magickal steps to success you can greatly increase the efficiency of your seal – be it one for money, love, lust, revenge or whatever!

MAGICKAL SUCCESS IS A GAME OF GIVE AND TAKE

While it is beyond any occultist’s means to give anyone a 100% guarantee as to the efficacy of magick in the securing of results, the

desired outcome can be attained that much more quickly and easily if one supplements the magickal power of the Black Seals with a little bit of good old-fashioned hard work in the direction of a specific and worthwhile goal.

In other words, do not just sit back and wait for results to happen; help the powers of the Seal along with a combination of both physical and mental work and you will complete your quest for power and success that much more quickly.

With the assistance of the magick energies imbued in the Black Seal you should find yourself receiving original ideas, meeting the right people and, generally, attracting the appropriate circumstances with which to attain each and every one of your goals.

Good luck.

PART ONE

THE POWERS AND OFFICES OF THE 72 SPIRITS OF THE FALSE MONARCHY

As mentioned in the Introduction, the Double Seal of Solomon originated in the latter part of the Middle Ages, and the same holds true for both Ritual of Evocation and Ceremonial Magick which involved both Celestial and Demonic methods by which one could achieve his or her desires. Unfortunately, the often bizarre – sometimes quite unnecessary – process for summoning said angelic or demonic forces was so long and complicated that the entire Science was almost entirely the exclusive plaything of the idle rich in search of something with which to pass the time, and the average man in the street was, more often than not, left out in the cold. Add to this the fact that this often expensive (everything had to be brand new and preferably the most expensive of its kind) practice seldom, if ever, seemed to work and you are left with a very sad state of affairs. Yet despite all these apparent drawbacks with which to fuel the sceptic's fire, magick is still a power force that does have the ability to bring about changes in one's circumstances once the unnecessary veil of magick circles, incenses, hard to obtain herbs, robes and candles shaped like a mummy's case, has been torn aside to reveal the lost source of magickal power.

It is the sole purpose of this book to show you that even the maligned world of Black Magick contains within its dark and mysterious links with the Racial Mind a relatively safe and simple way of attaining material success.

DEMONS, DEMONS AND MORE DEMONS

Any textbook of magick owned or written by a practitioner of the occult is known in the trade as a grimoire, and contained within the pages of the older grimoires is a wide selection of techniques by which

one can enlist the magick help of a multitude of demons ranging from 666 to a slightly larger figure of 1,758,064,176 which includes princes and leaders of lesser demons and assorted evil spirits.

A favourite request of ancient magicians was to be shown where buried treasure could be found and how to bypass the guardian spirit. Oh yes, didn't you know, every buried treasure has at least one nature spirit standing his guard over the goods.

Each one of the 1,758,064,176 demons has its own particular sphere of influence, but for the moment we will contain ourselves to dealing with just the seventy-two spirits of that famous brass vessel. Time enough later to become acquainted with the rest of the gang.

THE WORLD OF THE BLACK MAGICIAN

A true Black Magician or Satanist, call him what you will, does not slaughter a baby a night. He does not abduct virgins from Church Fetes. He does not desecrate graves. And most important of them all, he does not grovel to an invisible God.

The Black Magician is an individual in a conformist's world. He enlists the aid of demons and evil spirits and calls them brother. He lives each and every day to the full. Money, pride, ego and sexual delight are recognised for being what they really are – human and very normal desires and inclinations.

The world of the real Black Magician is one of satisfied desire. Are you ready to join it?

THE SEVENTY-TWO SPIRITS OF THE FALSE MONARCHY

Before dealing with the actual Rites of Evocation and the Black Seals themselves, let us study the powers and offices attributed to the controlling evil spirits of the seventy-two different Black Seals of Solomon the King.

Their names, powers and offices are as follows:

AGARES, a Duke from the Eastern Quarter and one of the three demons serving the demon Lucifuge – being Lucifer's prime minister. He can appear in a somewhat deceiving form of a harmless old man

sitting astride a crocodile. Resting upon his left wrist can be found a hawk whose eyes will never leave your own. He has the power to bring Back runaways, teach all languages and to destroy the spiritual atmosphere of any person or place.

AINI, a mighty and powerful Duke has the body of a handsome young man, but with three different heads, the head to the left of his body is like a hissing serpent, the head atop his body resembles a man with stars marked upon his forehead, and the head to the right of his body is a cat. He sits astride a large viper and is armed with a blazing torch with which he spreads destruction with gay abandon. He has the power to grant one much cunning and gives true and honest answers to questions regarding all secret things.

ALLOCEN, a Grand Duke of Hell, appears in the form of a large horned horseman complete with the head of a roaring lion. He rides an enormous black horse with blazing red eyes. When he speaks his voice is said to be quite hoarse. He can provide the magicians with spirit familiars, teaches the secrets of Heaven and Hell. He has at his command thirty-six legions of lesser demons.

AMDUSCIAS, another Grand Duke of Hell, he appears first in the form of a unicorn, but will, at the insistence of the magician, assume a more human shape. He can give one faithful familiars. He is also able to cause beautiful music to be heard in the atmosphere. Trees are said to bend to his and the magician's will. He has at his command twenty-nine legions of lesser demons.

AMON, a mighty and powerful Marquis of Hell, he appears as a fire-breathing snake-headed wolf. He is very important and has a great deal of power at his command. He will assume a human shape if so commanded. He will sometimes appear as an owl-headed human attired in a scarlet surcoat, vest and breeches, with shiny black riding boots. He has the power to bring about reconciliations between friends and enemies, procure the love of another, and reveals both the past and the future. He has at his command forty legions of lesser demons and evil spirits.

AMY, an important president, he appears first as a pillar of fire and then as a man. He can reveal to the magician the location of buried

treasure and to evade the guardian spirit. He grants good familiars to the magician and can help one to understand the mechanics of astrological interpretation.

ANDRAS, a Marquis of Hell, he appears in the form of an owl-headed angel riding a black wolf. He brandishes a sharp bright sword. He has the power to create discord and mistrust. He has at his command thirty legions of lesser demons.

ANDREALPHUS, a mighty and powerful Marquis, he appears first as a peacock, accompanied by a great noise, but later assumes the form of a human. He teaches one the secrets of astronomy, geometry, and all things related to measurements.

ANDROMALIUS, a great Duke and Earl, he appears in the somewhat mundane form of a man holding a serpent in his hands. He has the power to return stolen goods to their rightful owner, and reveals the thief's identity. He discloses all wickedness and underhanded dealings of both friends and enemies, and reveals the site of buried and hidden treasure.

ASMODAY, a powerful King he, like his fellow demon Aini, has the somewhat dubious honour of having three heads, the head to the left is one of a bull, the head atop his body is like a man, and the head to the right of his body is that of a ram. His feet are those of an enormous web-footed goose, a serpent's tail hangs to the ground, and he vomits fire from his three heads. He appears astride the back of a large dragon, and carries a large pointed spear. Many powers are attributed to him, he can grant one the power of invisibility, give one skill in handicrafts, teach all aspects of a mathematical problem, answers all questions, reveals the precise location of buried treasure, and can grant one any virtue.

ASTAROTH, a powerful Grand Duke from the Western Quarter, he appears as an ugly angel sitting astride a dragon. He holds a viper in his two hands. Being a treasurer of Hell, he is blessed with awesome and terrifying infernal powers. He knows both the present and past – and, if ordered, will reveal the future. He can grant the bearer of his Seal secret knowledge about all things. He will, it is said, talk willingly about the fall of spirits. His wife is the Phoenician goddess of the moon, Astarte.

BAAL, is the King of the East and the commander of all the legions of Hell. He appears as a human, but sometimes will appear with the head of a toad or a cat – sometimes all three. He can grant the bearer of his Seal the power to move about invisible to the eyes of man. He speaks with a rough sounding voice, and can give wisdom.

BALAM, a horrible and mighty King, he appears with three heads, the head to the left of his body is like that of a bull, the head atop his body is that of a man, and the head to the right of his body is that of a ram. He rides astride a ferocious bear. His eyes are aglow with the fires of Hell, and he has the tail of a serpent. He speaks with only those few mortals who are well-versed in the science of Demonology. He will grant those brave enough to evoke his aid great wit, and an understanding of all things past, present and future. He also gives the power of invisibility. He will often appear naked, and carries a hawk on his left wrist.

BARBATOS, a great and powerful Duke, he is one of three demons in the service of Satanachia the commander of the first legion of Hell; he grants the bearer of his Seal the location of buried or hidden treasures guarded by enchantments. He knows all things past, present and future, and can bring about reconciliations.

BATHIN, a mighty Duke, he is one of three demons in the service of a lieutenant general of the armies and legions of Hell – namely, Fleuretty. He appears as a masculine young man adorned with the tail of a serpent, riding a white stallion. He can grant one the knowledge of herbs and precious gems. His sphere of influence also includes long voyages to distant countries.

BELETH, a terrible and dangerous King, he appears only when it suits his own purposes and is not to be trusted. He rides a pale horse preceded by many minstrels and musicians. His only ability is that of producing love between a man and a woman. He is of the Order of the Powers.

BELIAL, a great and mighty King, he appears as a beautiful and naked angel in fiery chariot and speaks with a very pleasant sounding voice. He will cause friends and enemies of the person bearing his Seal to grant him any favour asked of them. He also gives excellent familiars.

BERITH, a mighty Duke, he appears in the form of a scarlet clad soldier upon a large red stallion. When he speaks his voice is clear and very persuasive. He can advise his evoker on things past, present and those yet to be. He can cause the bearer of his Seal to be awarded a great many dignities; but be warned, he is a notorious liar and cannot be trusted.

BIFRONS, a great Earl, he usually appears in the form of a monster, but will assume a more pleasing shape if commanded by the magician. He gives to the bearer of his Seal an understanding of astrology, geometry and all things of a mathematical nature.

BOTIS, a great president and Earl, he is one of three demons who loyally serve Agaliarept the commander of the second legion of Hell. He appears like that of a viper with large teeth and horns. In his left hand is a huge sword. He reconciles friends, and answers questions about the future.

BUER, a great president, he also serves Agaliarept, and appears in the shape of a bright star in the midst of a great fire. He gives wisdom to those who seek it, and also teaches philosophy. His Seal can also be used to aid in the healing of disease.

BUNE, a mighty and powerful Duke, he has the body of an infernal dragon with three heads, the head to the left of his body is that of a savage dog, the head at the centre resembles a griffin's, and the head to the right is that of a man. His voice is pleasant, and he can give riches and comfort to the bearer of his Seal. He can also make the bearer of his Seal eloquent and wise, and answers all questions truly.

CAIM, a great president, he appears in the form of a large black bird with flaming red eyes, but will later assume the shape of a powerful man, brandishing a sharp sword. He can grant the bearer of his Seal power to understand the forces of Nature and the voices of animals. He can also answer questions regarding the future. He was once of the Order of Angels.

CIMERIES, a mighty and powerful Marquis, he appears as a soldier sitting on a black horse. He teaches the bearer of his Seal logic, grammar and reveals the location of buried treasure. He commands all the evil spirits of that darkest of continents, Africa.

DANTALIAN, a mighty Duke, he appears with the faces of both men and women, and always has a book in his hand. He is very learned in such things as the arts and sciences, and knows all human thoughts and can give an individual possessing his Seal the power to control minds.

DECARABIA, a Marquis, he appears on the earth as a bright star at the centre of a pentagram, but will assume the shape of a man if so desired. He has the power to grant bird-like familiars, and knows virtues of the herbs and precious stones.

ELIGOR, a great Duke, he appears in the somewhat unusual form of a good and kindly knight carrying a lance and sceptre. He discovers, for bearer of his Seal, hidden mysteries, and kindles love and lust between the sexes. Eligor, above all others, is perhaps the most cordial of all the seventy-two spirits.

FLAUROS, a powerful Duke, he first appears as a savage leopard, but will, at the magician's command, assume the shape of a horrific old man with eyes aflame with the fire of Hell. He has the power to punish your enemies and will protect you from all forms of temptation. He will also give truthful answers regarding all things past, present and future.

FOCALOR, a strong and powerful Duke, he appears on the earth as a man with the wings of a griffin. He has the power to control the winds and the seas, and to drown the male enemies of the bearer of his Seal and nature.

FORAS, the Grand President of Hell, he commands twenty-nine legions, and appears on earth as a robust white-haired old man who teaches the art of invisibility, imparts great wisdom and wit, reveals treasures and returns lost or stolen things.

FORNEUS, a great and powerful Marquis he appears as a roaring sea-monster. He has the ability to teach all arts and sciences, gives knowledge of all languages, and can make the bearer of his Seal to be loved by his enemies.

FURCAS, a Duke who appears on earth as a very cruel old man with a long beard and wild hair. He arrives seated on a very pale horse, and holds in his hand a sharp pointed spear. He is skilled in philosophy.

FURFUR, a great Count of Hell, he first appears as a comet with a fiery tail, but will, at the magician's command, assume the shape of an angel and speaks with a very hoarse voice. He can produce love between those in wedlock, raise storms, and give answers to questions about things of a secret and divine nature. He commands twenty-six legions of lesser, more servile demons and evil spirits.

GAAP, a great and powerful president and prince of Hell, he appears when the sun is in one of the southern signs, and appears on earth in the shape of a normal human being. He teaches one philosophy, excites love or an intense hatred, drives men mad, gives true answers to questions of the past, present and future, and will transport people quickly from place to place. He was of the Order of the Powers.

GAMYGYN, a great Marquis, he first appears as a small horse, but later takes on the shape of a man. His voice is, as with so many of our demonic friends, rather hoarse. He can bring the dead back to life, especially those who have died in sin.

GLASYALABOLAS, a mighty president, he appears on the earth in the form of a large winged dog. He can make the bearer of his Seal invisible, discerns the true intentions of any person, and is the driving force behind all murders and acts of violence.

GOMORY, a Duke, appears on earth as a beautiful young woman riding astride a camel. He/She procures the love of young women, and reveals the location of buried treasure.

GUSION, a mighty and powerful Duke, he appears when the sun is in the star sign of Leo, answers all questions truthfully, reconciles enemies, and can award the bearer of his Seal a great many dignities.

HAGENTI, a great president, he appears first as an enormous bull with the wings of a griffin, but will, if so desired, assume human shape. He is skilled in alchemy and can grant the bearer of his Seal great and lasting wisdom.

HALPAS, another great Earl, he appears on earth in the form of a dove and speaks with a – surprise, surprise – very hoarse voice. He destroys towns with hell-fire, and punishes the wicked.

IPOS, a mighty Prince and Earl of Hell, he appears as goose footed,

hare tailed, lion headed angel – and you think you've got problems. He can grant the bearer of his Seal great courage, wit, and knowledge of all things past and future.

LERAJIE, a powerful Marquis, he appears on the earth in the somewhat mundane form of an archer, attired in green and carrying a bow and arrow on his person. He causes battles between persons or countries.

MALPAS, a Grand President in the infernal scheme of things, he first appears as a crow, but will, at the magician's command, assume a human form. I'll let you guess what his voice sounds like. He can destroy one's enemies, brings material possessions, and gives good familiars.

MARCHOSIAS, a mighty Marquis, he appears on earth in the form of a wolf with the wings of a griffin and the tail of a hare. He vomits fire on anyone who comes near him. He gives true answers to questions on any subject, and is exceptionally loyal to those who evoke him.

MORAX, a great Earl and President, he appears as a bull-headed man. He teaches astrology, gives good familiars, and knows the virtues of all herbs and precious gems.

MURMUR, another great Duke and Earl, he appears in the shape of a gallant and fierce soldier, riding on a griffin, wearing a crown on his head. He is highly skilled in philosophy, and causes spirits to appear at once when summoned by the magician. He was of the Order of Angels.

NABERIUS, a great and powerful Marquis of Hell, he appears in the shape of an enormous crow. He is skilled in the arts and sciences, and can restore lost honours and dignities.

ORIAS, a Count of Hell, he appears on the earth in the form of a lion riding a horse, holding two serpents in his right hand. He can transform the magician's enemies into loyal friends, bestow dignities, and teaches, as do so many of his demonic brothers, astrology.

OROBAS, a great and noble Prince, he appears first as a horse, but will later assume a normal human shape. He discerns all things past, present and future; he can cause the magician or bearer of his Seal to receive an assortment of dignities and honours, and he, like Marchosias, is very loyal to those who evoke him.

OSE, a great and powerful President, he appears at first in the shape of a leopard and later in human form. He gives true answers concerning all divine and secret things.

PAIMON, a great King and very loyal to Lucifer, he appears when summoned as a crowned man sitting astride a camel, and is preceded by musicians of all shapes and sizes. He teaches those who evoke his aid all the arts and sciences. He gives dignities, and can grant the bearer of his own Black Seal the power to control the thoughts and actions of others. He is of the Order of the Dominions.

PHOENIX, a great and powerful Marquis, he appears as a bird rising from the ashes, and has the voice of a child. When in the form of a human – at the will of the magician – he teaches all sciences, poetry, and obeys all orders very well indeed.

PROCEL, a great and powerful Duke, he appears on the earth as an angel. He is skilled in all matters of geometry and the sciences. He will speak of mysterious and hidden things if asked. He was of the Order of Powers.

PURSON, a great and noble King, he is one of the three demons who loyally serve Fleuretty – a lieutenant general of all the legions of Hell. When evoked, he appears as a lion-headed man carrying a viper in his two hands and riding a camel, and is preceded by a multitude of trumpeters. He reveals the location of hidden treasure, discerns all the magician desires, gives true answers to all questions, and supplies good familiars.

RAUM, a great Earl, he appears in the form of a crow, but will, if ordered by the magician, assume a human form. He has the power to destroy whatever the magician desires, reconciles friends and enemies, produces love for the bearer of his Seal, brings money and success, discerns all things and is of the Order of the Thrones.

RONOBE, a great Marquis and Earl, he appears on the earth in the form of a horrific monster. He teaches the arts, gives one an understanding and knowledge of all languages. He can make the bearer of his Seal well loved by friends and enemies alike.

SABNACK, a mighty Marquis, he appears as a lion-headed soldier

riding upon a pale horse. He protects buildings and cities from hostile attack, he also gives good familiars.

SALEOS, a Duke, he appears dressed as a soldier riding a crocodile. Upon his head is to be found a crown. His only purpose is to promote love and desire between the sexes.

SEERE, a mighty and powerful Prince, he appears on earth as a beautiful young man riding a white, winged horse. He brings things to pass suddenly in respect to the magician's will, discovers the identity of thieves, and is indifferently good or bad.

SHAX, a powerful Marquis, he appears as a dove and speaks with a hoarse voice. He has the power to bring blindness, deafness and insanity to any enemy, discovers all hidden secrets, produces material possessions and money.

SOLAS, a mighty and noble Prince, his appearance is that of a raven, and then later that of a man. He teaches astrology and the virtues of herbs and precious stones.

SYTRY, a great and powerful Prince, he appears with a leopard's head and the wings of a griffin, but will, at the magician's command, assume human form. He procures love between the sexes, and can make women lustful. This seal will, no doubt, be of very little interest to male readers.

VALAC, a great and mighty President, he appears on earth as a tiny angel on the back of a two-headed dragon. He can lead the magician to where a treasure is buried.

VALEFOR, a Duke of Hell, he is the driving force behind all thieves, and is one of three demons in the service of Sargatanas – brigadier general of Hell's legions. His appearance is that of a many-headed man or lion.

VAPULA, a powerful Duke, he appears in the form of lions with the wings of griffins. He can grant the bearer of his Seal great skill in manual, scientific and philosophical pursuits.

VASSAGO, a mighty Prince, he can reveal all things past, present and future. He also reveals the location of lost or stolen goods. He is

perhaps the only demonic force used openly in both Black and White Magick – he is good by nature.

VEPAR, a great Duke of Hell, he/she appears on the earth as a mermaid, and creates storms at sea.

VINE, a great King and powerful Earl, appears on the earth as a terrible and horrific monster, but will, at the will of the magician, assume a more pleasing form. He will reveal the identity of other magicians and witches, uncover things hidden, and makes known the future. He can also bring death and destruction on both the land and the sea.

VUAL, a great Duke, he appears first as an enormous camel, but afterwards he will transform himself into an Egyptian. He procures the love of women and maidens, discerns the future, and gains the friendship of enemies. He was of the Order of Powers.

ZAGAN, a great King and powerful president, he appears first as a gigantic bull with the wings of a griffin, but will, at the magician's command, transform himself into the likeness of a man. He can bestow upon those bearing his Seal a great sense of humour, and can make fools wise. He is also highly skilled in the art of alchemy.

ZEPER, a great Duke of Hell, he appears as an armed soldier in a scarlet uniform. He arouses love and passion in the hearts of women.

These then are the names, powers and offices of the seventy-two spirits of the brass vessel as mentioned in the Lemegeton, and ancient grimoire, and it can be an enjoyable pastime deciding just which spirit to evoke for any particular problem, for it can be seen that there is a veritable multitude of spirits available to an individual with which to accomplish every possible need and desire.

But having chosen the spirit, when to evoke its aid for the maximum benefit?

Each Duke, King, Marquis, Count, Earl and Prince have their own particular hours of the day and night in which they may be called forth from their places in the dimension known as Hell, and these will be given at the commencement of each Rite of Evocation as described in Part Three of this book.

Where to practice the acts of demonic evocation? It can be performed anywhere, but it is best if one is in a place far removed from any distraction such as the noises of modern day living, as this will interrupt one's concentration.

No magick circles, no candles, no hard-to-obtain herbs.

THE KING SOLOMON PROTECTION CHANT

Stand facing East and recite the following chant aloud and with feeling, all the while imagining that your body is surrounded by a halo of very bright white light:

“Alija Laija Laumin Otheon!”

With the image of the halo of bright white light firm in your mind, recite:

“Eliam yoena Adonai caudus ebrel eloyela agiel, ayom sachadon ossuseles eloym de liomar elynla lelia yazi zazall Unnela ovela dilatam Saday alma panaim alym canal densy usami yasas calipi calfas sasna saffa sadojay aglata pantomel amriel azien Phanaton sarze penerion ya Emanuel Jod jaleph amphia than Domirael alowin. Amen.”

For your own safety, this ancient protection chant must be recited three consecutive times immediately prior to the evoking any one of the spirits – or any form of black occult force – as described in this book.

HOW TO USE THE SEAL OF SOLOMON TO GAIN THE OBEDIENCE OF SPIRITS

The Double Seal of Solomon (Figure 1-1) has its origins in that time when magick was the order of the day – the Middle Ages – and became popular with Magicians employing the varied methods described in lurid detail within the pages of one or more of the black grimoires, which were so popular at the time, to gain all their materialistic desires.

Now perhaps is a good time to mention the fact that the only real difference between so-called black and white magick is that one deals openly with the Evil One and his minions, and the ‘good guys’ system

with forces and spirits obviously of the same class but are called by more friendly and less frightening names in the scheme of things. Both systems of magick contain precise instructions on how to acquire money (materialistic desire), how to punish one's enemies and rivals (destructive magick), and how to win the love of another (controlling an individual's thoughts and emotions), etc. The dividing line between the forces of black and white magick is very thin indeed.

When all is said and done ... good and evil are simply states of mind.

The Double Seal of Solomon must be drawn on the reverse side of whatever one of the Black Seals you use in respect of your individual desire as this can help you to gain the obedience of the evoked spirit-force.

PART TWO

THE BLACK SEALS

"What is it," you might ask, "that gives the Black Seals their magickal and supernatural properties?"

The answer to that question is as follows:

1. The seventy-two different Black Seals as described within the pages of this book are, in themselves, a source of highly potent occult power, for they are filled not only with the magick power instilled into them by their original creators and the powers which they symbolise, but also with the thousands upon thousands of occult practitioners that have instilled into them their belief – and desires – down through the ages.
2. The Black Seals represent the dark, mysterious and powerful dimensions that surround our own, and the intelligences residing therein. They are the doorway between the worlds of Light and Darkness; the occult barriers between Good and Evil, and exist both physically and astrally.
3. The Black Seals are therefore magnets to which are drawn the magickal force they symbolise, and which the bearer of the Seal can use to better his life in an infinite variety of ways.

Such are the magickal and supernatural properties latent within each and every Black Seal of Solomon the King.

IF IT'S TUESDAY, THIS MUST BE DESTRUCTIVE MAGICK

Very soon now, you'll be eyeing the seventy-two different Black Seals of the False Monarchy of Spirits and deciding on which one is appropriate for your own personal desire.

But wait, the best is yet to come.

Having chosen the Black Seal and decided that what you desire above all else is actually worth the fun-and-games of dealing with, if

you'll pardon the expression, demonic forces, you must now decide on the most propitious day on which to perform this most darkest of arts.

The correlation of days and planets, along with their own particular sphere of influence, is as follows:

- Sunday: Sun – Money; health matters, hope, success, material gain.
- Monday: Moon – Spirits; necromancy, women, water, ocean, ships, occult and psychic powers, theft.
- Tuesday: Mars – Sex; anger, hatred, death, destruction, enemies, war.
- Wednesday: Mercury – Business dealings, writing, contracts, communications.
- Thursday: Jupiter – Gambling; growth, plenty, long journeys, honour and dignity, riches, desires.
- Friday: Venus – Love; affection, friends, strangers, luxury.
- Saturday: Saturn – Real estate; debts, furniture.

So there you have it, now let's take a look at the Seals themselves.

Figure 1-2
THE BLACK SEAL OF AGARES

For making a runaway return home; punishing a powerful person

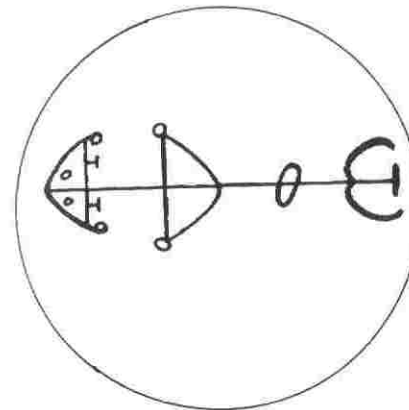
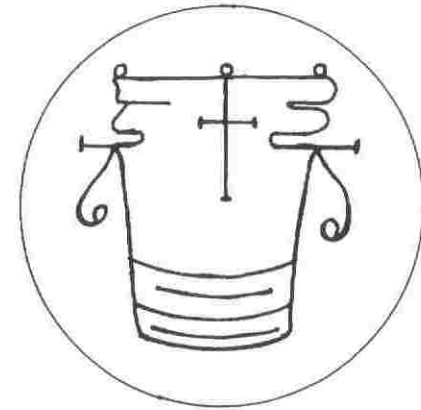

Figure 1-3
THE BLACK SEAL OF AINI

For discovering another person's private affairs

Figure 2-1
THE BLACK SEAL OF ALLOCEN

For improving one's understanding of astrology

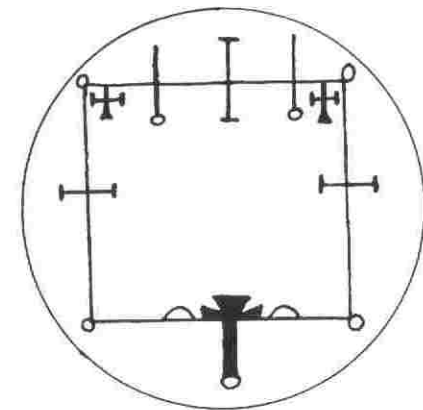

Figure 2-2
THE BLACK SEAL
OF AMDUSCIAS
 For gaining the help of
 the spirit world

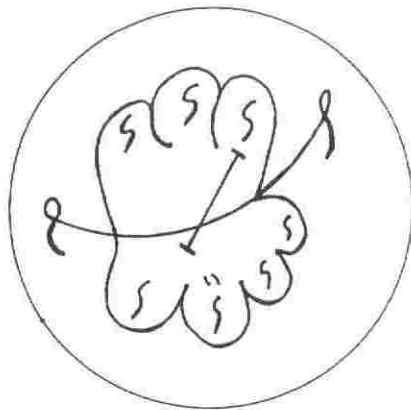
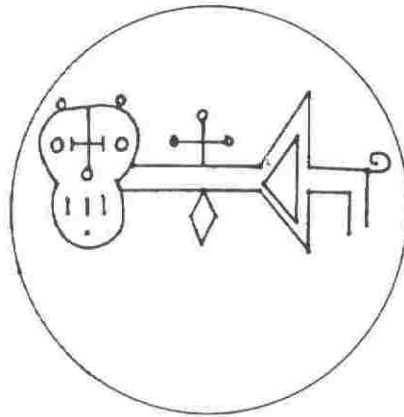

Figure 2-3
THE BLACK SEAL
OF AMON
 For bringing love or
 reconciliation;
 development of
 clairvoyance

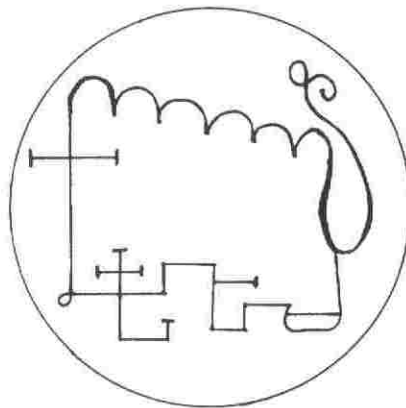

Figure 3-1
THE BLACK SEAL
OF AMY
 Improve understanding
 of astrology; find buried
 treasure

Figure 3-2
THE BLACK SEAL
OF ANDRAS
 For causing havoc
 amongst enemies

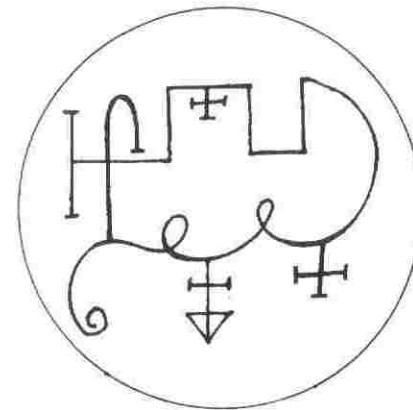
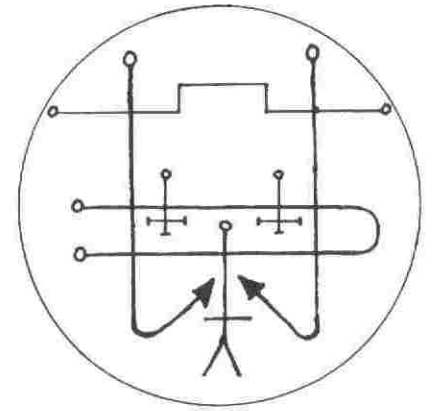

Figure 3-3
THE BLACK SEAL
OF ANDREALPHUS
 For passing exams in
 mathematics and
 geometry

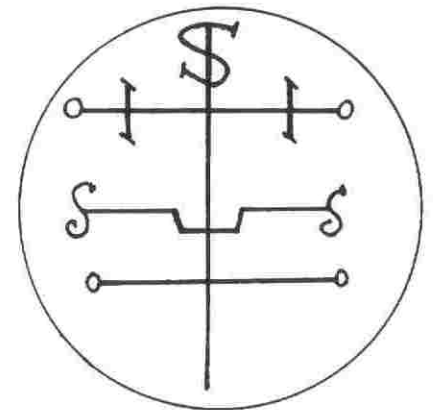

Figure 4-1
THE BLACK SEAL
OF ANDROMALIUS
 For regaining stolen
 property; learning the
 identity of a thief

Figure 4-2
**THE BLACK SEAL
 OF ASMODY**

For success in astral
 projection; also
 mathematics and
 excellence in any type
 of handicraft

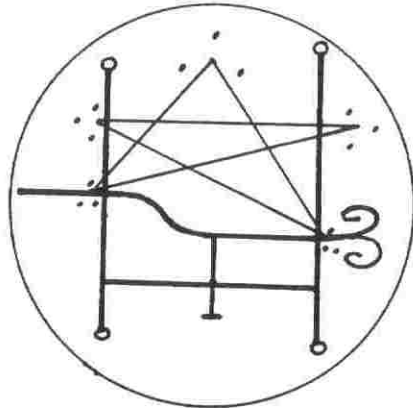

Figure 4-3
**THE BLACK SEAL
 OF ASTAROTH**
 For developing
 clairvoyance; also skills
 in the arts and sciences

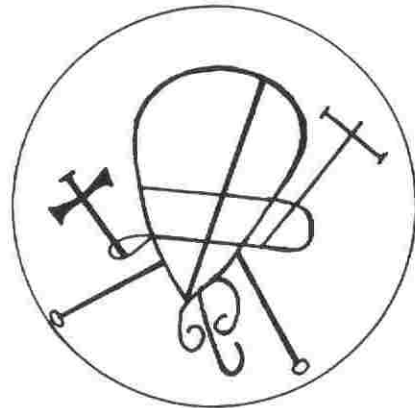

Figure 5-1
**THE BLACK SEAL
 OF BAAL**
 For success in astral
 projection or the
 acquirement of wisdom

Figure 5-2
**THE BLACK SEAL
 OF BALAM**

For success in astral
 projection; also for
 developing wit and the
 powers of clairvoyance

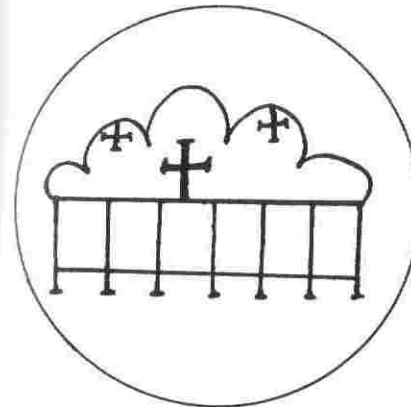
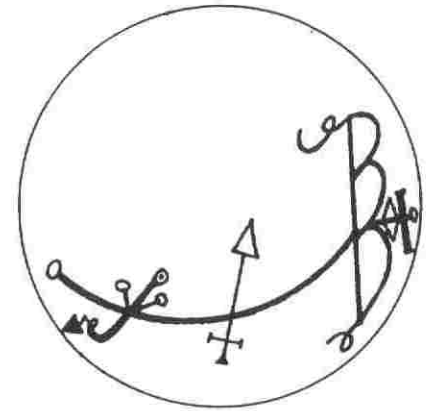

Figure 5-3
**THE BLACK SEAL
 OF BARBATOS**
 To influence those in
 authority or
 reconciliation with
 friends

Figure 6-1
**THE BLACK SEAL
 OF BATHIN**
 For successful travel
 between two countries
 or the understanding of
 herbs and precious
 stones

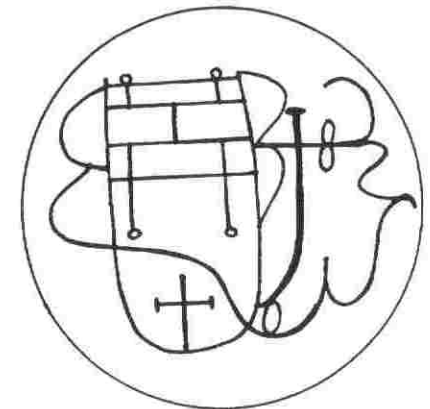

Figure 6-2
THE BLACK SEAL
OF BELETH
 To win the affections of
 another

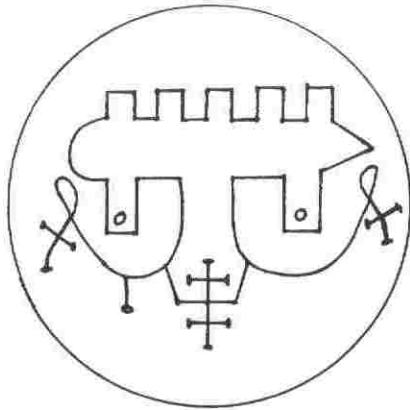
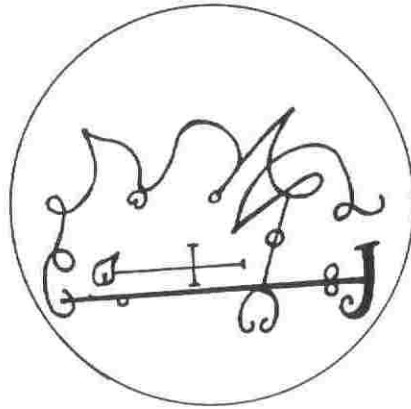

Figure 6-3
THE BLACK SEAL
OF BELIAL
 For gaining favours
 from both friends and
 enemies

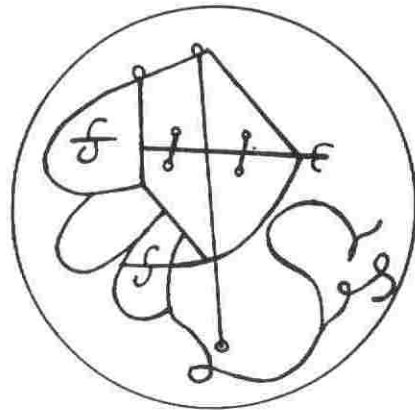

Figure 7-1
THE BLACK SEAL
OF BERITH
 For success in politics

Figure 7-2
THE BLACK SEAL
OF BIFRONS
 For success in all
 branches of
 mathematics

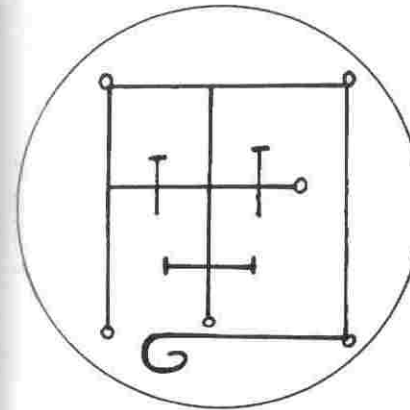
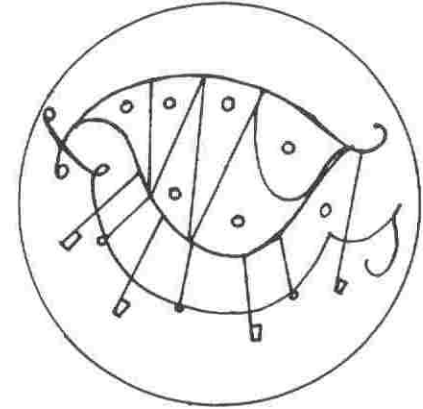

Figure 7-3
THE BLACK SEAL
OF BOTIS
 For reconciliation with
 a friend or enemy

Figure 8-1
THE BLACK SEAL
OF BUER
 For the improvement of
 logic and reason; also
 for an understanding of
 philosophy; and the
 healing of a disease

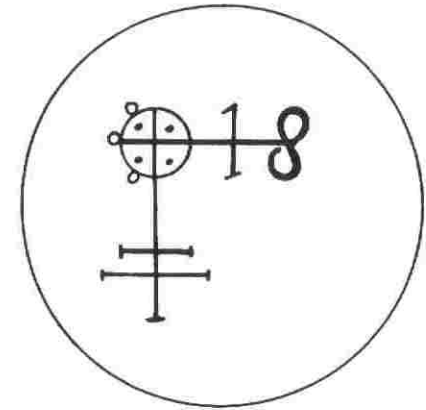

Figure 8-2
THE BLACK SEAL
OF BUNE

For the attraction of riches, eloquence and wisdom

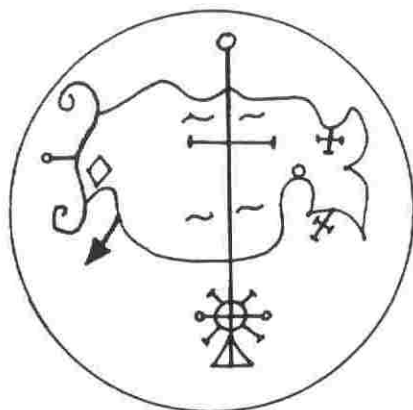
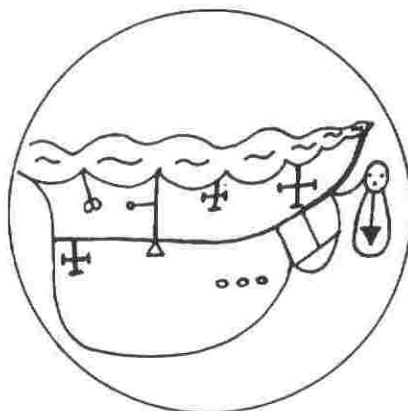

Figure 8-3
THE BLACK SEAL
OF CAIM

For building a unity with all animals and birds

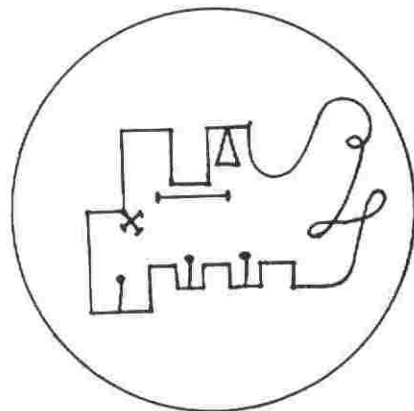

Figure 9-1
THE BLACK SEAL
OF CIMERIES

For a better understanding of logic and grammar

Figure 9-2
THE BLACK SEAL
OF DANTALIAN

For development of telepathy and the power to influence the thoughts of others

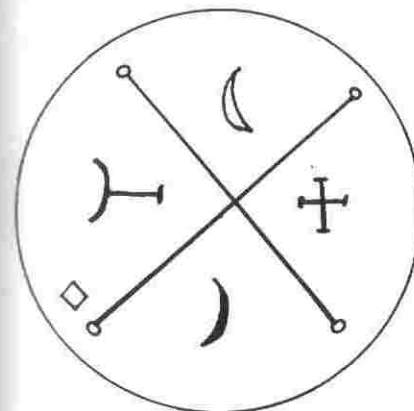
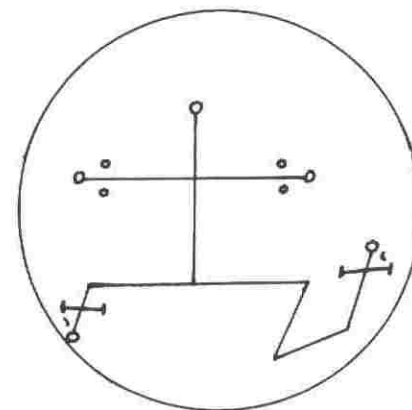

Figure 9-3
THE BLACK SEAL
OF DECARABIA

For a better understanding of herbs and precious stones

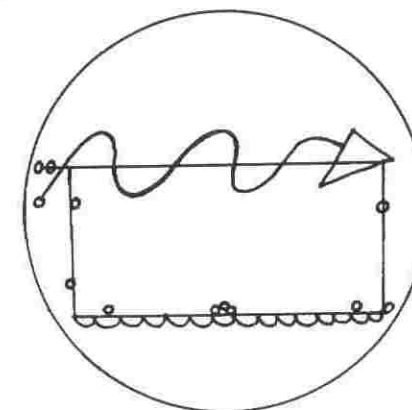

Figure 10-1
THE BLACK SEAL
OF ELIGOR

To bring disharmony or to promote sexual pleasure

Figure 10-2
**THE BLACK SEAL
 OF FLAUROS**
 For the total destruction
 of an enemy or,
 conversely, for total
 protection of one's self

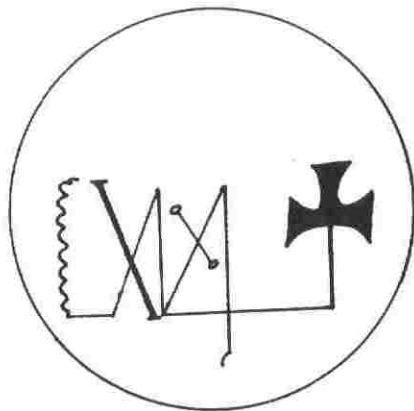
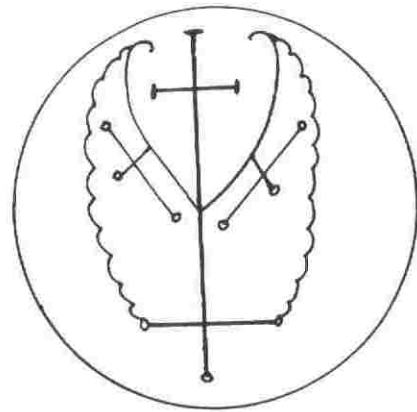

Figure 10-3
**THE BLACK SEAL
 OF FOCALOR**
 For the protection of
 those at sea

Figure 11-1
**THE BLACK SEAL
 OF FORAS**
 For the development of
 wit, eloquence and
 wisdom

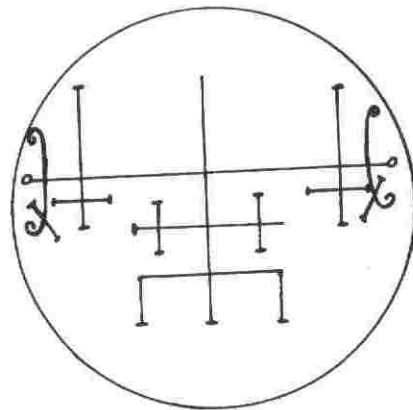

Figure 11-2
**THE BLACK SEAL
 OF FORNEUS**
 To help one learn a
 foreign language

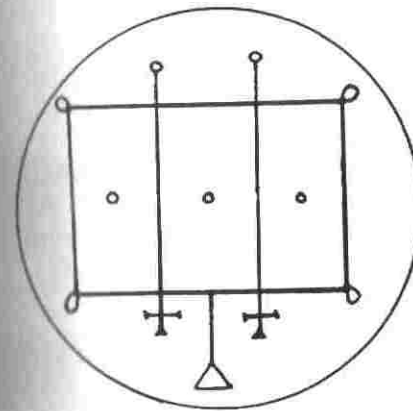
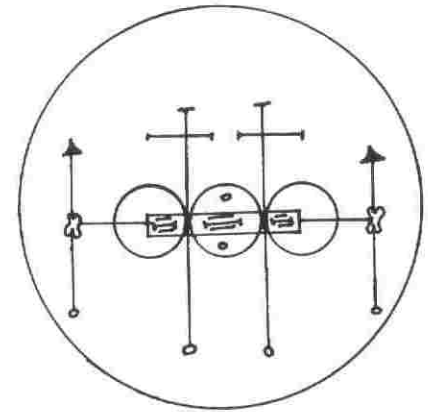

Figure 11-3
**THE BLACK SEAL
 OF FURCAS**
 To make one's self
 more rational, and
 logical in thought

Figure 12-1
**THE BLACK SEAL
 OF FURFUR**
 To rekindle a mate's
 interest; also the occult
 power to control or
 create storms

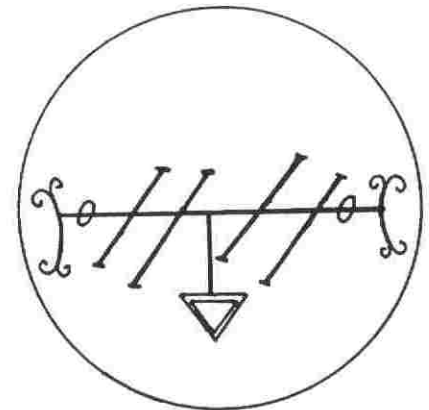

Figure 12-2
**THE BLACK SEAL
 OF GAAP**
 To drive an enemy mad

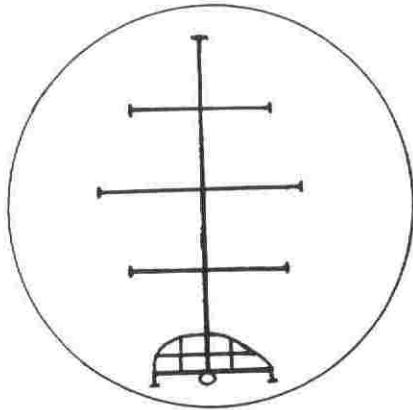
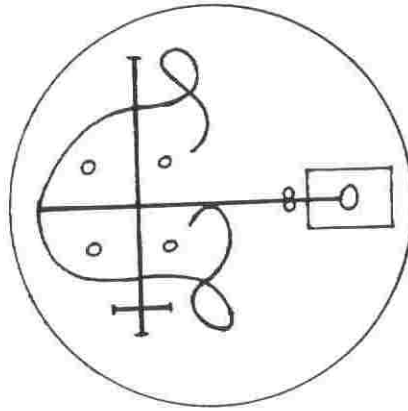

Figure 12-3
**THE BLACK SEAL
 OF GAMYGYN**
 For the development of
 mediumistic powers

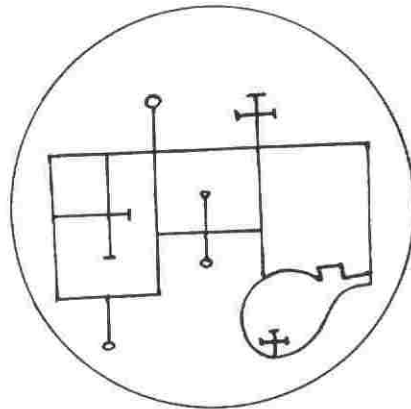

Figure 13-1
**THE BLACK SEAL OF
 GLASYLABOLAS**
 For an instant, basic
 understanding of an art
 or science

Figure 13-2
**THE BLACK SEAL
 OF GOMORY**
 To attract young women

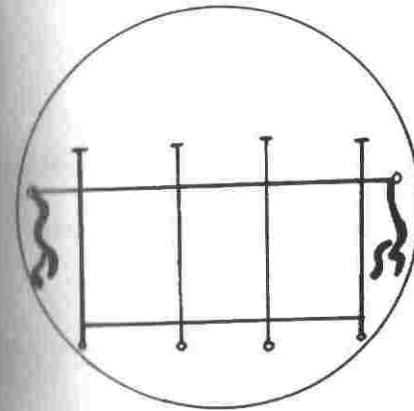
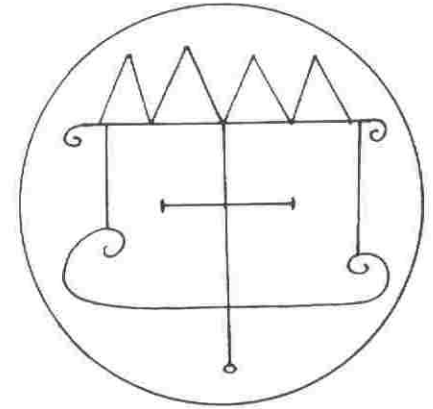

Figure 13-3
**THE BLACK SEAL
 OF GUSION**
 For reconciliation with
 one's enemies

Figure 14-1
**THE BLACK SEAL
 OF HAGENTI**
 For an understanding of
 alchemy

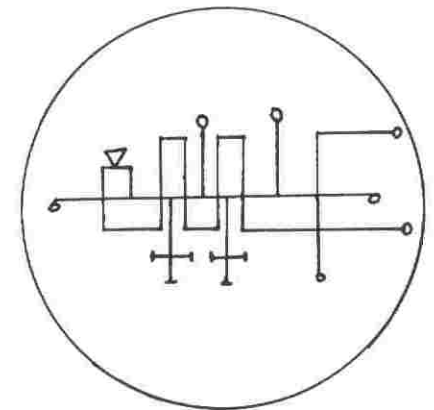

Figure 14-2
**THE BLACK SEAL
 OF HALPAS**
 For the punishment of
 enemies

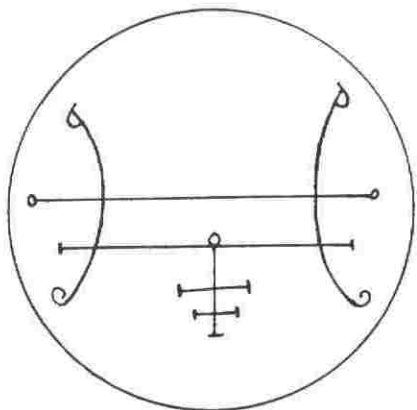
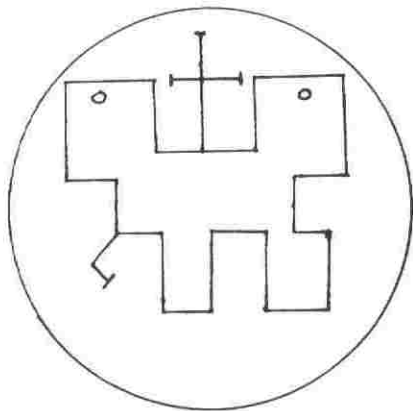

Figure 14-3
**THE BLACK SEAL
 OF IPOS**
 For making one's self
 courageous

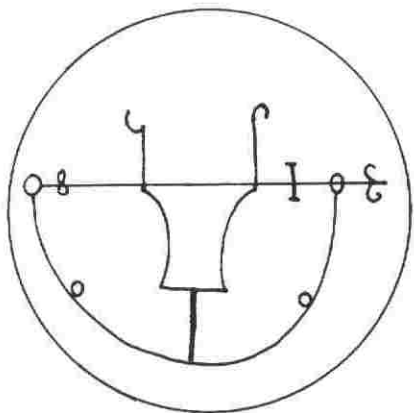

Figure 15-1
**THE BLACK SEAL
 OF LERAJIE**
 To cause distrust
 between people

Figure 15-2
**THE BLACK SEAL
 OF MALPAS**
 For thwarting the plans
 and actions of enemies

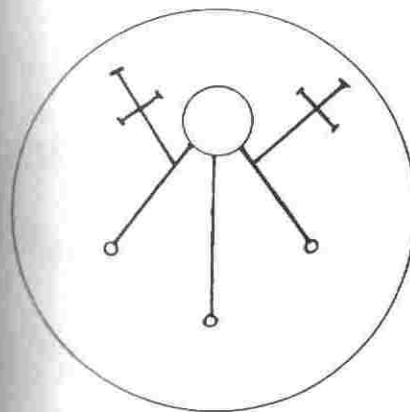
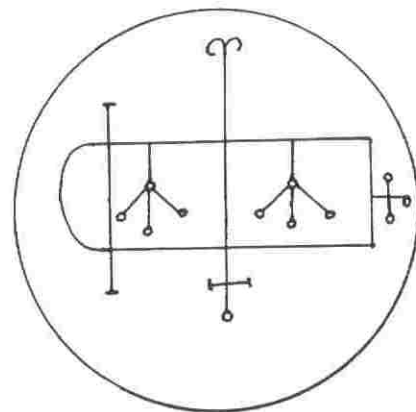

Figure 15-3
**THE BLACK SEAL
 OF MARBAS**
 To cure a disease; also
 for skill in mechanics

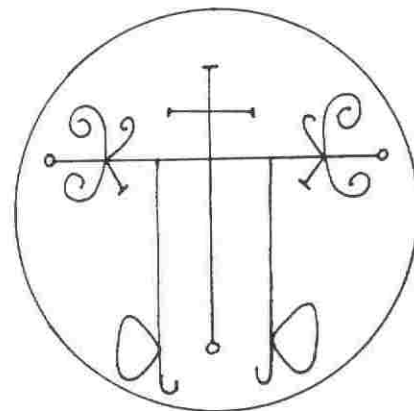

Figure 16-1
**THE BLACK SEAL
 OF MARCHOSIAS**
 For courage and valour
 in armed combat

Figure 16-2
**THE BLACK SEAL
 OF MORAX**
 To improve
 understanding of the
 sciences

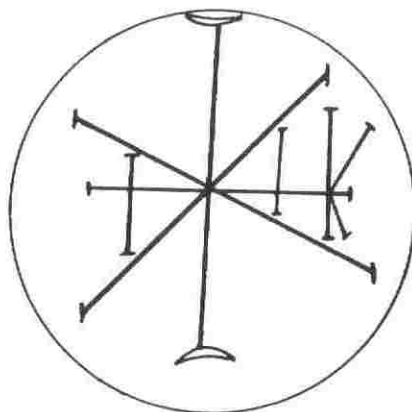
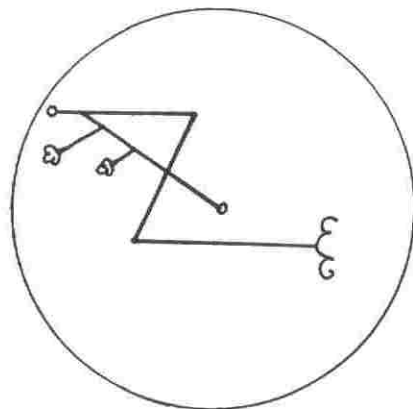

Figure 16-3
**THE BLACK SEAL
 OF MURMUR**
 To assist in
 communicating with
 the dead

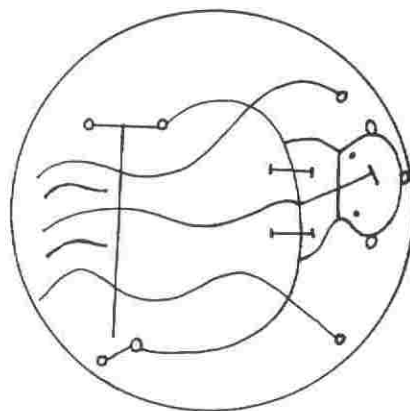

Figure 17-1
**THE BLACK SEAL
 OF NABERIUS**
 For the restoration of
 lost honours and
 dignities

Figure 17-2
**THE BLACK SEAL
 OF ORIAS**
 For understanding the
 workings of astrology

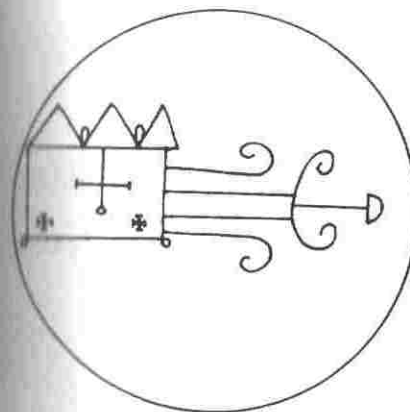
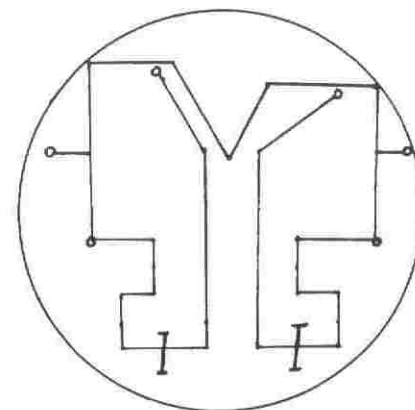

Figure 17-3
**THE BLACK SEAL
 OF OROBAS**
 For material and social
 advancement

Figure 18-1
**THE BLACK SEAL
 OF OSE**
 For acquiring secret
 knowledge

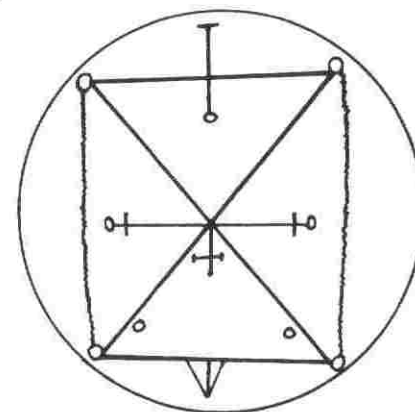

Figure 18-2
**THE BLACK SEAL
 OF PAIMON**

For controlling the
 thoughts and actions of
 others

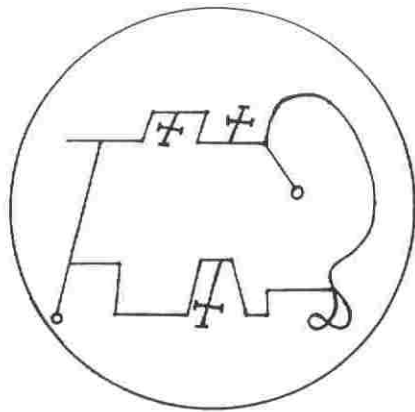
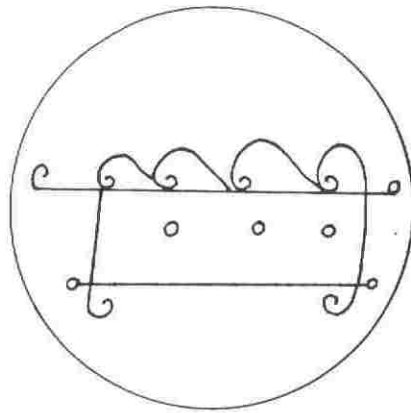

Figure 18-3
**THE BLACK SEAL
 OF PHOENIX**
 For writing good poetry

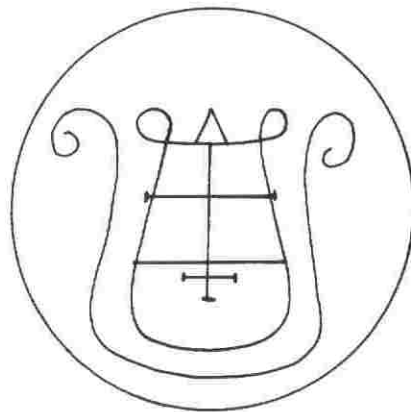

Figure 19-1
**THE BLACK SEAL
 OF PROCEL**
 For improving one's
 knowledge of all matters
 divine and infernal

Figure 19-2
**THE BLACK SEAL
 OF PURSON**
 For the discovery of lost
 treasure

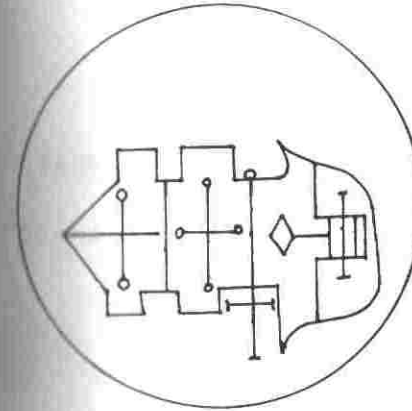
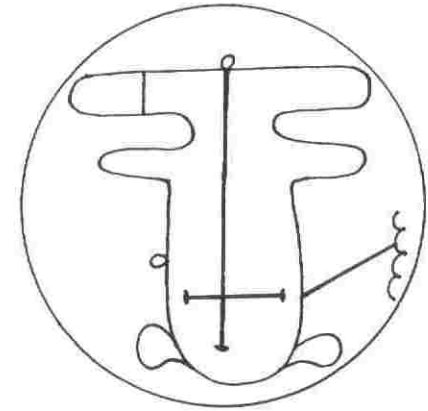

Figure 19-3
**THE BLACK SEAL
 OF RAUM**
 To attract riches

Figure 20-1
**THE BLACK SEAL
 OF RONOBE**
 To gain the favour of
 both friends and
 enemies

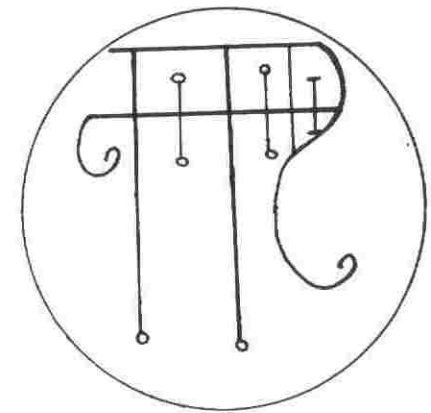

Figure 20-2
**THE BLACK SEAL
 OF SABNACK**
 For creating a protective
 occult barrier around a
 building

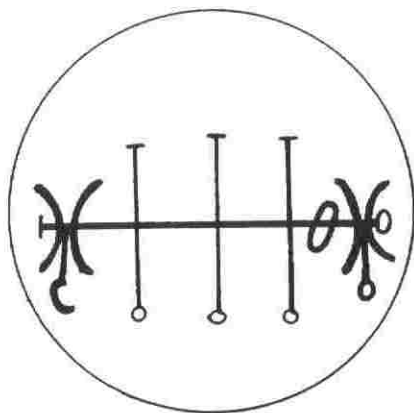
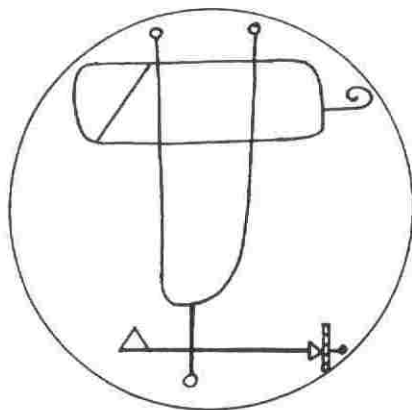

Figure 20-3
**THE BLACK SEAL
 OF SALEOS**
 For winning the love of
 another



Figure 21-1
**THE BLACK SEAL
 OF SEERE**
 For discovering the
 identity of a thief

Figure 21-2
**THE BLACK SEAL
 OF SHAX**
 For attracting money

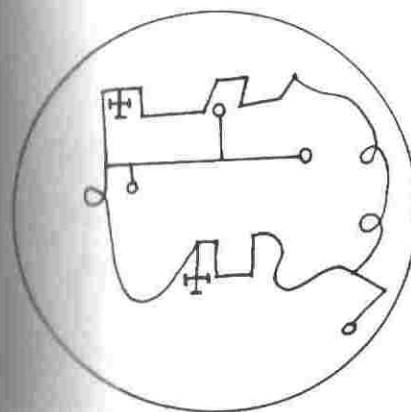
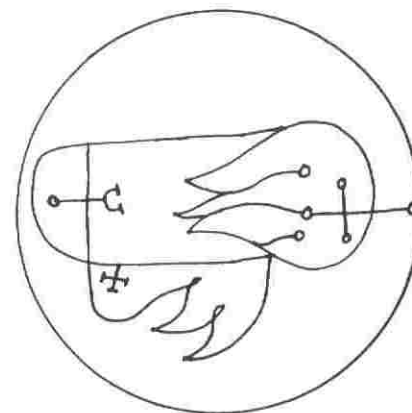

Figure 21-3
**THE BLACK SEAL
 OF SOLAS**
 For understanding
 astronomy

Figure 22-1
**THE BLACK SEAL
 OF SYTRY**
 To inflame women with
 lust

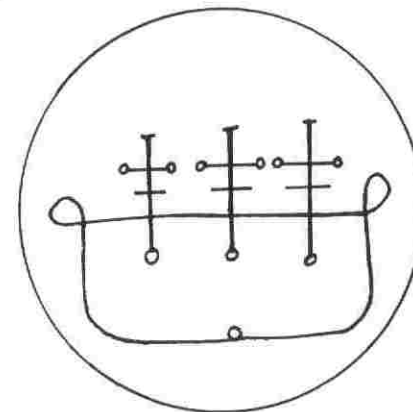

Figure 22-2
**THE BLACK SEAL
 OF VALAC**
 For finding the location
 of buried treasure

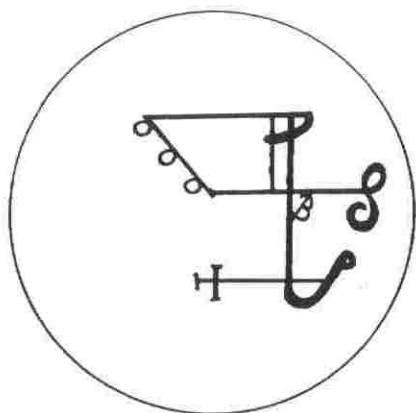
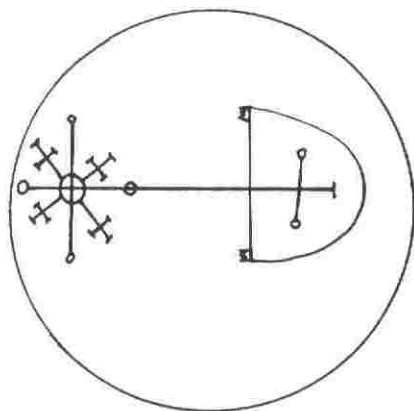

Figure 22-3
**THE BLACK SEAL
 OF VALEFOR**
 For awakening occult
 power

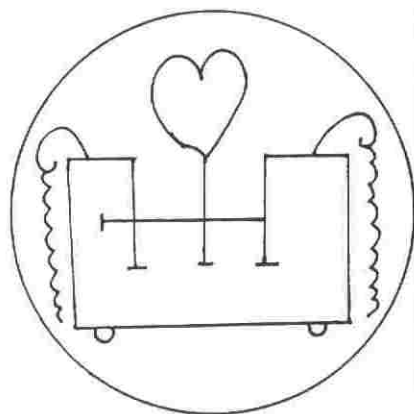

Figure 23-1
**THE BLACK SEAL
 OF VAPULA**
 For skill in any manual
 trade

Figure 23-2
**THE BLACK SEAL
 OF VASSAGO**
 For discovering the
 location of a lost or
 stolen object

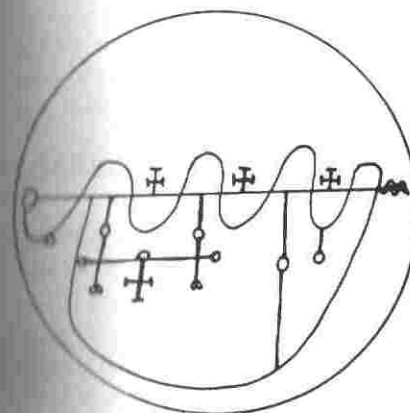
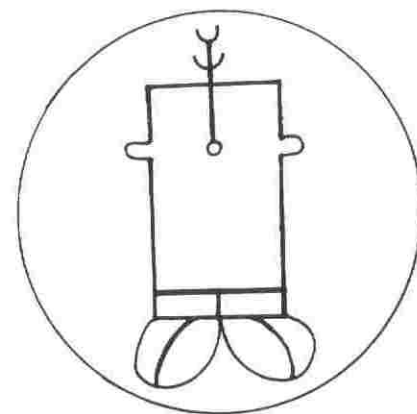

Figure 23-3
**THE BLACK SEAL
 OF VEPAR**
 To increase occult
 power

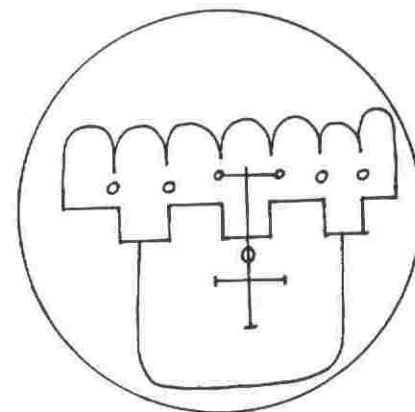

Figure 24-1
**THE BLACK SEAL
 OF VINE**
 For secret occult
 knowledge

Figure 24-2
THE BLACK SEAL
OF VUAL

To secure the love of a woman

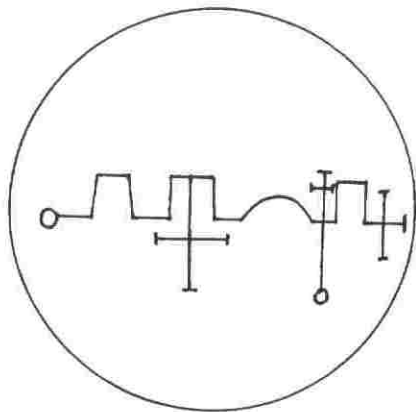
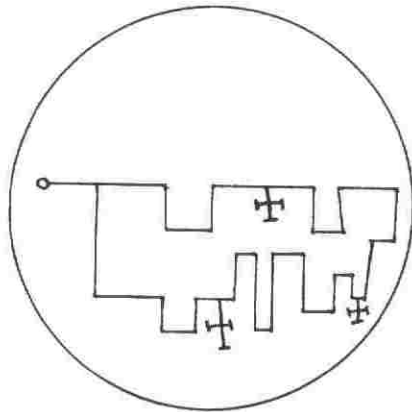

Figure 24-3
THE BLACK SEAL
OF ZAGAN
To help a fool become wise

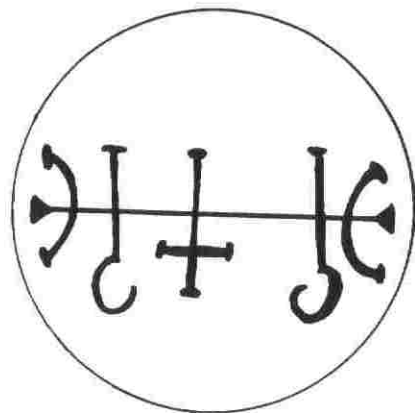

Figure 25-1
THE BLACK SEAL
OF ZEPER

To arouse desire in a woman

PART THREE

THE POWER OF THE BLACK SEALS

It is a widely held belief in occult circles that to personally create one's own magickal seal, is to create an instrument of vast and ever-lasting magickal power.

Why is this so?

Because you are instilling into it a part of your own self; the stuff dreams are made of, and every time that you look at it or touch it lightly with the tips of your fingers you are, in fact, reinforcing its own latent psycho-occultic power force with the magickal power of externalised mental desire.

CREATING YOUR BLACK SEAL

The Black Seals illustrated in the preceding section of this book can be, if so desired, engraved upon the metals that occult tradition holds are most acceptable to the spirit-force as symbolised by the said Seals; or, if this is beyond your current financial situation, you may simply draw the appropriate Seal for a individual desire or need upon a piece of stiff white paper measuring approximately six inches square. An ordinary black felt pen should be used for this piece of magickal work.

Whatever method is chosen, it is important that you use time and patience in creating the Seal. Even in the field of Black Magick, patience is a virtue.

CHARGING YOUR BLACK SEAL

Having chosen and created your own personal Black Seal, you must then have it charged with the vast storehouse of supernatural power surrounding us with invisible dimensions of unlimited power.

Proceed as follows:

Sit upright in a comfortable chair, with your back supported, and take a few deep breaths; inhaling through your nose and exhaling through your mouth, to be as relaxed and free from all physical tension as is possible.

Close your eyes and take the phone off the hook. Dim the lights, but do not sit in total darkness. If you have a red candle handy then you may use this to bring some illumination to the room, however, this is not absolutely essential. Make your mind passive and receptive to the occult forces you are evoking.

Now, that you have achieved the desired state of relaxation, comes the most important part of all: keeping your eyes shut, and your mind free of thoughts, visualise an intense beam of bright red light flowing from above down into the Black Seal held in your hand. Keep this visualised image of supernatural power clear and firm in your mind for at least fifteen minutes; all the while believing that the seal will cause your inner desires to be released into the outer objective world of tangible reality. At the end of the fifteen minutes, image in your mind the desire as having been fulfilled. See it clearly and in detail for a full five minutes. Finally, imagine the beam of bright red light flowing into and becoming part of the seal. Open your eyes and go about your affairs in a normal and everyday manner.

You now have in your possession a most potent occult tool.

THE WHYS AND WHEREFORES OF THE SEALS

When using a seal to develop clairvoyance, it should be used in conjunction with a psychic development exercise for the said power.

When using a seal to aid in the healing of a disease, it should only be used in conjunction with prescribed medical treatment.

When using a seal to develop an occult power, the seal should only be used in conjunction with separate exercises designed to develop the chosen power.

When using a seal to bring success in astral projection, it should be used in conjunction with one of the many techniques available for the development of this ability. (Finbarr International have books available on this.)

By following these tips, you will greatly increase your chances of success when using the Black Seals of Solomon the King.

THE KING AMAYMON INVOCATION

You are now ready to evoke and command the obedience of the seventy-two different spirits of the brass vessel as described within the pages of the Lemegeton for assistance in the attaining of your desires – both spiritual and material.

To aid you in the evoking of these sometimes deceptive spirits, this Invocation should be read aloud, slowly and with feeling:

"O thou Great and Powerful King Amaymon, who rulest by the divine powers of the Supreme God, EL, over all the spirits, both superior and inferior to thee, but especially over the Infernal Order in the Dominion of the Eastern Quarter, I invoke and command thee by thee particular and true Name of God, by the true God Whom thou dost worship and obey, by the Seal of thy own and particular creation, by the most mighty and powerful Names of God almighty, JHOVAH, TETRAGRAMMATON, Who cast thee out of Heaven with the rest of thine kind; by all the other potent and great Names of God, creator of Heaven and Earth and Hell, and all of those contained therein; by their powers and the virtues they possess; by the Name PRIMEMATUM, which commands the whole host of Heaven.

"Do thou force and compel the Spirit (*name of Spirit*) here into my presence, in a fair and comely shape, without injury to myself or to any living, or dead creature, that he may accomplish my desired outcome, so that I will achieve my desired end, whatsoever it might be, provided that it is proper, and true to his appointed sphere of influence, by the powers of the awesome God, El, Who hath created and doth dispose of all things, celestial, aerial, terrestrial and infernal."

The above Invocation must be repeated a total of three times, and must be recited while facing the East.

Having thrice invoked King Amaymon in this manner, you will be virtually assured of success in securing the assistance and help of the chosen spirit in whose sphere of influence your particular problem falls.

THE RITES OF EVOCATION

You are now on the threshold of genuine Black Magick from the Middle Ages, with which you can begin to change unpleasant current conditions while creating the future of your own choosing. Easily and virtually automatically, whatever you truly desire can become solid reality for you to see, feel and possess in life.

These Rites of Evocation are secret, and should be respected as such. When you begin your personal descent into the unknown, be absolutely certain; this is important, that you have the object of your desire clearly in mind. Doubt of any kind is dangerous in the Shadow World of evil spirits. Magick does not take kindly to being summoned by individuals without any purpose in life. So please, know exactly what it is you want out of life.

Each Rite of Evocation should be performed once every week until you have fulfilled your desire. Then select another Rite of Evocation with which to fulfil your next desire in life. It is a good idea to make a short list, listing your desires in order of importance and work from that – erasing the desires one-by-one until the page is empty.

This is where all you have learnt in preceding sections of this book begin to form into a collective, life enriching, magickal whole.

WHAT THE BLACK SEALS COULD DO FOR YOU

If you are short of money, a Black Seal could bring you some much needed money. If you are disappointed with your love-life, a Black Seal could bring you all of the happiness and romantic fulfilment you desire. If you are suffering an unpleasant disease, a Black Seal could help you to recover your health. If you are seeking the development of psychic occult powers, a Black Seal could help you develop these special powers of the mind and soul. If you are feeling sad or lonely, a Black Seal could bring you endless joy and everlasting friendships. If you are the victim of malicious psychic attack, a Black Seal could turn the evil on your attacker. If there is any area of your life in need of changing, a Black Seal could help you to lead the type of life you desire.

If you fit into any of those categories, then please read on. This part of the book could be your 'Open Sesame' to a totally new and different life, for it is within the succeeding pages that you will find the Ancient

Rites of the Forbidden Science of Black Magick, which have the potential of great things, and which, according to occult lore, hold the key to success in all magickal undertakings.

Long before you have reached the end of this final part of this book, you will – without doubt – have found the way with which to release the power of Black Magick into any area of your life and, in so doing, perhaps change the unpleasant aspects of it forever.

Yes, there have been a rather large amount of similar books promising 'instant miracles' of health, wealth and happiness, I've written just such books, providing you practiced and developed mind powers over a period of weeks or even months.

What makes this particular method of working miracles so different from all those other self-help books which are currently on the market, is the fact you do not have to wait weeks or months before putting the powers into practice in your life. The seals can be used instantly, on any day of the week, for every possible need or desire.

Long and meaningless discourses on things philosophical will not be found here; only sound, practical instruction on how to evoke ancient powers for a wide variety of purposes.

I know what you're thinking: "If these Black Seals are so darn great, then why doesn't this guy use them himself?" Well, I did.

THE DAY MY HORSES CAME HOME; OR, I DID IT – SO CAN YOU!

Whilst researching this book, I had cause to attend the March 23rd 1985, race meeting at Rosehill Racecourse, situated approximately twenty-minutes drive from my home. Realising that this would be an ideal opportunity to test some of the famous Black Seals, I promptly created and charged the Black Seal of Bune, with which one may attract money.

Later that day ...

Upon reaching Rosehill Racecourse, I studied the form-guide which listed the various horses for that day's race meeting. As my eyes travelled over the often 'exotic' names, certain ones seemed to possess a magnetic-like quality; holding my eyes in a 'psychic grip' as if to say: "I am the horse to place your money on in this race."

The horses names were: Jewel of Light, Luck's a Lottery, Astrolin,

and Daybreak Lover. If you care to check the record books for that day, you will find that they all came home in either first, second or third place. I walked away with a smile.

EXAMPLES OF HOW TO USE THE MAGICKAL POWER OF THE BLACK SEALS

Prior to actually describing the various Rites of Evocation of the seventy-two different spirits of the brass vessel, I have here listed below an example of just some of the ways in which the Black Seals may be put to use.

Obtaining Money. Let us suppose that, like just about everyone else within the confines of the earth, you would like to attract some more of that highly elusive commodity ... money!

You would first decide on how you would like the green stuff to appear in your life. If you like to gamble, then a win at the horses (now that sounds familiar) would be the most suitable. If, on the other hand, you do not like to gamble, then perhaps an unexpected pay rise or an inheritance is the way by which you would like the money to arrive. Whatever way you select for this magickal happening to occur, stick with that choice, and create a Black Seal for that purpose. The Black Seal of Bune is used to attract money, and that it is the Seal you must use for this particular purpose.

So engrave or draw the Seal upon either a copper plaque or a six inch square piece of paper respectively, and perform the Rite of Evocation as explained later.

Then as you sit having charged the Seal in the manner described in Part 3 of this book, you would visualise in your mind the money flowing into your life in the chosen manner.

The same holds true for attracting love, friendship, good health, protection from psychic attack, and a number of other positive life experiences. You just decide on what and then select the appropriate Black Seal.

REMEMBER

Now follow the Evocations. Remember to begin with the King Solomon Protection Chant. Then engrave the Black Seal on a piece

of copper 6 inches square (or with a black pen on a piece of white card of the same size). The Double Seal of Solomon shown at the front of the book must be engraved or drawn on the reverse side of the Seal. You then recite the King Amaymon Invocation three times before making the Evocation. Next 'charge' the Seal and then dismiss the spirit - instructions on this will be found towards the end of the book. Carry the Seal with you or on your person until your will is accomplished. You can 're-charge' your Seal once or twice a week, if you so wish.

THE EVOCATION OF AGARES

Hour of Evocation: Agares is evoked at any hour from sunrise until noon, with the following:

"In the Power of the Names ADONAI, ELOHIM, JAH and SADAI, I evoke and do command thee, O Great and Noble Spirit Agares, do thou forthwith manifest - in no uncertain manner - thy presence in this thine own Black Seal; and, by the power of the everlasting fire, manifest that which I desire.

"Be then ruled and governed by me in the Name of the Eternal, Living and True God, HELIOREM. Amen."

THE EVOCATION OF AINI

Aini is evoked at any hour from sunrise until noon. Aini is then evoked with the following words-of-power, which are spoken in a clear and firm tone of voice:

"I evoke, conjure and command thee, O Most Noble and Powerful Spirit Aini, by the Name JEHOVAH, which Adam heard and spoke; by the Seal of BASDATHEA, by this Name PRIMEMATUM, which Moses named, and the earth opened and swallowed Corah, Dathan and Abriam; do thou forthwith manifest thyself in this Black Seal of Power, and manifest that which I desire.

"Be thou ruled and governed by me in the Name of the Eternal, Living and True God, HELIOREM. Amen."

THE EVOCATION OF ALLOCEN

Hour of Evocation: Allocen is evoked at any hour from sunrise till noon.

"I conjure and constrain thee, O most noble Spirit Allocen, by these Seven Names with which Solomon did bound thee and thy fellow devils, in the brass vessel; being, ADONAI, PRERAI, TETRAGRAMMATON, ANEXHEXETON, INESSENSATOAL, PATHUMATON and ITEMON; do thou forthwith manifest in the Black Seal of thy powers, and fulfil my will in all things that are within your sphere of influence.

"Be thou ruled by and governed by me in the Name of the Eternal, Living and True God, HELIOREM. Amen."

THE EVOCATION OF AMDUSCIAS

Hour of Evocation: Amduscias is evoked at any hour from sunrise till noon. Amduscias is then evoked with the following words-of-power, which must be spoken aloud in a clear and firm tone of voice:

"I conjure thee, O Mighty Spirit Amduscias, by Him to Whom all creatures are obedient, by this ineffable Name, TETRAGRAMMATON JEHOVAH, by which even the elements are overthrown, the air is shaken, the sea turns back, the all consuming fire is generated, the earth moves and all the hosts of all things celestial, of things terrestrial, of things infernal, do tremble and are of confusion; come into this Seal, come I command thee, and manifest all those desires that I have within me.

"Be thou ruled and governed by me in the Name of the Eternal, Living and True God, HELIOREM. Amen"

THE EVOCATION OF AMON

Amon is evoked at any hour from sunset to sunrise.

"I conjure thee, O Grand and Noble Spirit Amon, by the particular and True Name of God to whom thou owest thine obedience; by the Name of your King who rules over thee, do thou come into this Black Seal; come and in so doing, fulfil each and every one of those desires which are within an area of influence governed by thee. Come therefore in the name of ADONAI ZEBAOOTH; come unto me. ADONAI SADAY, King of Kings, commands thee.

"Be thou ruled and governed by me in the Name of the Eternal, Living, and True God, HELIOREM. Amen."

THE EVOCATION OF AMY

Hour of Evocation: Amy is evoked at any hour of daylight until the fall of twilight.

Recite the King Amaymon Invocation a total of three consecutive times. Amy is then evoked with the following words-of-power:

"I conjure thee, O Spirit Amy, by all the most noble, glorious and efficacious Names of the Great and Incomparable Lord the God of Hosts, come quickly and without delay, from whatsoever part of Heaven or Hell that thou art in at this time; come into this Black Seal, and make manifest that which I desire.

"Be thou ruled and governed by me in the Name of the Eternal, Living and True God, HELIOREM. Amen."

THE EVOCATION OF ANDRAS

Hour of Evocation: Andras is evoked at any hour from sunset to sunrise.

"I conjure thee, O most powerful and mighty Spirit Andras, and command thee by the most Holy Names of ELOY, ADONAI, ELOY, AGLA and ZEBAOOTH which thee must obey; by the four beasts before the Throne, having eyes before and behind; by the fire which is about the Throne, by the Holy Angels of Heaven, and by the Mighty Wisdom of God, to bless this Seal with thy own infernal powers, and to make manifest all of my known and unknown desires immediately and without delay.

"Be thou ruled and governed by me in the Name of the Eternal, Living and True God, HELIOREM. Amen."

THE EVOCATION OF ANDREALPHUS

Hour of Evocation: Andrealphus is evoked at any hour from sunset to sunrise.

"I conjure, evoke and command thee, O Spirit Andrealphus, by all the names with which thou can be summoned and constrained. Come then by the Names EHEIEH, IOD, TETRAGRAMMATON ELOHIM, EL, ELOHIM GIBOR, ELOAH VA-DAATH, EL ADONAI TZABAOOTH, ELOHIM TZABAOOTH, SHADAI and all the Holy Names of the Archangels of the True God; do I command

thee to come into this Seal, and to manifest every desire that falls within thy own sphere of influence.

“Be thou ruled and governed by me in the Name of the Eternal, Living and True God, HELIOREM. Amen.”

THE EVOCATION OF ANDROMALIUS

Hour of Evocation: Andromalius is evoked at any hour from sunrise to noon.

“I conjure thee, O Mighty Spirit Andromalius, by the True and Living God, by the true God, by the holy God, Who spoke and all was made, Who commanded, and all things were created. I conjure and command thee by the three Secret, Powerful and Holy Names of AGLA, ON and TETRAGRAMMATON; by the Name ADONAI, which Moses named, and there came up locusts over all the lands of Egypt and devoured what the hail had left; come therefore, and make manifest my desire in no uncertain manner.

“Be thou ruled and governed by me in the Name of the Eternal, Living and True God, HELIOREM. Amen.”

THE EVOCATION OF ASMODOY

Hour of Evocation: Asmoday is evoked at any hour of the day or night.

“I call thee, O Great and Powerful Spirit Asmoday, in the Name and by the power and dignity of the Omnipotent and Immortal Lord God of Hosts, JEHOVAH TETRAGRAMMATON, sole Creator of Heaven, Earth and Hell, and all things which swim in the seas, which walk upon the earth, which fly through the skies, do I call thee to come and make thy presence known to me by manifesting all the desires within and without me.

“Be thou ruled and governed by me in the Name of the Eternal, Living and True God, HELIOREM. Amen.”

THE EVOCATION OF ASTAROTH

Astaroth, a great and powerful duke, is evoked at any hour from sunrise until noon.

“Come Astaroth! Come, Astaroth! Come, Astaroth! conjure thee, O wicked Spirit Astaroth, by the words and virtues of God, by the

powerful God unto Whom all demons are submitted, I conjure thee again, in the name of Father and of the Son, and of the Holy Ghost. I command thee by Him Who shall appear with flames to judge the living and the dead, unto Whom is all honour, praise and glory. Come therefore, promptly, obey my will; appear and bring into being that which is desires and wishes fulfilled.

“Be thou ruled and governed by me in the Name of the Eternal, Living and True God, HELIOREM. Amen.”

THE EVOCATION OF BAAL

Hour of Evocation: Baal is evoked at any hour of the day or night.

“I invoke thee, O Spirit Baal, in the Name of Satan and in the name of all other evil spirits, to make haste and imbue this Black Seal with thy infernal authority.

“Be thou ruled and governed by me in the Name of the Eternal, Living and True God, HELIOREM. Amen.”

THE EVOCATION OF BALAM

Hour of Evocation: Balam is evoked at any hour of the day or night.

“I conjure and command thee, O Most Noble Spirit Balam, by the Name of JOTH, which Jacob learned from the Angel on the night of his wrestling and was delivered from the hands of his brother Esau; by the Name of your God AGLA, which Lot heard and was saved with his family; by the name ANEXHEXETON, which Aaron spake and was made wise; do I command, conjure, and demand of thee to fulfil my will in all things which seem good unto me.

“Be thou ruled and governed by me in the Name of the Eternal, Living and True God, HELIOREM. Amen.”

THE EVOCATION OF BARBATOS

Barbatos is evoked at any hour of the day, but only when the sun occupies the sign of Sagittarius.

“I conjure, evoke and constrain thee, O Mighty and Powerful Spirit Barbatos, by the Most High Names of God, HAIN, LON, HILAY, SABAOOTH, HELIM, RADISHA, LEDIEHA, ADONAI, JEHOVAH, YAH, TETRAGRAMMATON, SADAI, MESSIAS,

AGIOS, ISCHYROS, EMANUEL and AGLA, do I exhort thee and call thee, I command and constrain thee, here into this Seal; do thou forthwith, and without delay, come unto me and make manifest that which I desire.

“Be thou ruled and governed by me in the Name of the Eternal, Living and True God, HELIOREM. Amen.”

THE EVOCATION OF BATHIN

Hour of Evocation: Any hour from sunrise till noon.

“I conjure thee, O Spirit Bathin, by Him Who made you by the power and dignity of the three Names, TETRAGRAMMATON, ANEXHEXETON and PRIMEMATUM, do I summon and command on this day, and at this hour, your power and obedience in bringing unto me my desires and wishes.

“Be thou ruled and governed by me in the Name of the Eternal, Living and True God, HELIOREM. Amen.”

THE EVOCATION OF BELETH

Beleth is evoked at any hour of the day or night.

“O thou great and powerful Spirit Beleth, I invoke and command thee by the power of the Supreme Being, the everlasting Lord; by EYE, by SARAY, by the virtue of the Name PRIMEMATUM which commands the whole host of Heaven; do I conjure and command thee Spirit to appear forthwith and fulfil my desires in a most suitable manner.

“Be thou ruled and governed by me in the Name of the Eternal Living and True God, HELIOREM. Amen.”

THE EVOCATION OF BELIAL

Belial is evoked at any hour of the day or night.

“I conjure thee, O Spirit Belial, and command thee by the Most Holy Names of the True God, ELOY, ADONAI, ELOY, AGLA and TETRAGRAMMATON. I command thee by all the Kingdoms of God whose Name is JEHOVAH, to come without evil intent, without delay, to obey me in all my commands, without harm nor pain to my body or soul. Come, Belial, and make manifest my desire.

“Be thou ruled and governed by me in the Name of the Eternal, Living and True God, HELIOREM. Amen.”

THE EVOCATION OF BERITH

Hour of Evocation: Any hour from sunrise till noon.

“I conjure thee, O Spirit Berith, by the great living God, the Sovereign Creator of all things, to come into this Black Seal and make it powerful in accordance to thy own sphere of influence. I conjure thee again by the power and virtue of these Holy and Sacred Names EHIEH, IOD, TETRAGRAMMATON and SHADAI EL CHAI, come unto me and do my bidding in all things which are good for me.

“Be thou ruled and governed by me in the Name of the Eternal, Living and True God, HELIOREM. Amen.”

THE EVOCATION OF BIFRONS

Bifrons is evoked at any hour of the day.

“I conjure and command thee, O Spirit Bifrons, to enter into this Seal of infernal power. By the ineffable Names JEHOVAH ADONAI, ELOHE, ELION and JAH do I conjure, evoke and command thee into submitting to my will. By the ever-lasting goodness of God when he created man in His own likeness, do thou now come forthwith from wheresoever thee may be in Heaven or Hell, and obey that which is commanded of thee

“Be thou ruled and governed by me in the Name of the Eternal, Living and True God, HELIOREM. Amen.”

THE EVOCATION OF BOTIS

Botis is evoked at any hour of the day.

“I evoke and conjure thee, O Botis, and, fortified with the power of the Supreme Majesty, I strongly command thee by the Names of BARALAMENSIS, BALDACHIENSIS, PAUMACHIE, APOLO-RESEDES and the most potent of princes GENIO, LIACHIDE, Ministers of the Tartean Seat, chief princes known by the Mighty APOLOGIA of the ninth region of Hell, do I evoke and command, by the power and virtue of JEHOVAH TETRAGRAMMATON, that thee obey my wishes and desires.

"Be thou ruled and governed by me in the Name of the Eternal, Living and True God, HELIOREM. Amen."

THE EVOCATION OF BUER

Buer is evoked at any hour of the day or night, but only when the sun is in the sign of Sagittarius the Archer.

"I conjure thee, O Mighty and Powerful Spirit Buer, who hath dominion over all physical diseases; by the Name EMMANUEL, which the three children, Shadrach, Meshach and Abednego, chanted in the middle of the fiery furnace, and in the wisdom of the lord JEHOVAH were delivered; by the Name ALPHA and OMEGA, which Daniel uttered, and destroyed Bel and the Dragon, do I call thee forth from the Bottomless Pit, to hear and obey my commands.

"Be thou ruled and governed by me in the Name of the Eternal, Living and True God, HELIOREM. Amen."

THE EVOCATION OF BUNE

Hour of Evocation: Any hour from sunrise till noon.

"I conjure thee, O Grand and Powerful Spirit Bune, by the authority of God the Father Almighty, by all the powers and virtues of Heaven, Hell and the stars above, by the powers and virtues of all the Angels, do I summon and command thee, O Mighty Spirit, to come forth and bless this Seal with infernal power.

"Be thou ruled and governed by me in the Name of the Eternal, Living and True God, HELIOREM. Amen."

THE EVOCATION OF CAIM

Caim is evoked at any hour of the day or night.

"I command and conjure thee, O Spirit Caim, by the Name Zebaoth, which Moses named, and all the rivers and waters in the land of Egypt brought forth frogs, which ascended into the houses of the Egyptians, destroying all things; and by the Name Escerchie Ariston, which Moses also named, and the rivers and waters, of all the lands of Egypt were turned into blood; by the Name Adonai, which he of Egypt named, do I command and summon thee forthwith from wheresoever you may be, to come and make manifest that which I desire.

"Be thou ruled and governed by me in the Name of the Eternal, Living and True God, HELIOREM. Amen."

THE EVOCATION OF CIMERIES

Hour of Evocation: Any hour from sunset to sunrise.

"I conjure thee, O Mighty and Powerful Spirit Cimeries, by the Name ELION, on which Moses called, and there fell a great hail, such as never was seen at the time, nor since the creation of the world; by the Name HAGIOS; by the Seal of ADONAI, by those others, which are JETROS, ATHERNOROS and PARACLETUS do I summon and command thee to make this Seal a symbol of infernal power, and I also command thee, forthwith, to bring unto me all desired things.

"Be thou ruled and governed by me in the Name of the Eternal, Living and True God, HELIOREM. Amen."

THE EVOCATION OF DANTALIAN

Dantalian is evoked at any hour from sunrise to noon.

"I conjure thee, O Spirit Dantalian, by the powers and virtues of the Names ADONAI, ELOHIM, JAH, EL, ELOHE, ZEBOATH, ELION, ESCHERCE, TETRAGRAMMATON and SADAI EL CHAI: do thou forthwith come and make thy presence known unto me, in no uncertain manner, by making manifest that which I desire.

"Be thou ruled and governed by me in the Name of the Eternal, Living and True God, HELIOREM. Amen."

THE EVOCATION OF DECARABIA

Hour of Evocation: Any hour from sunset to sunrise.

"I evoke, conjure and command thee, O Most Noble and Majestic Spirit Decarabia, by the Name JEHOVAH, which Adam heard and spoke; by the Seal of BASADETHERA, and by the power and virtue of the Seven Sacred Names of ADONAI, PRERAI, TETRAGRAMMATON, ANEXHEXETON, INESSENSATOAL, PATHUMATON, and ITEMON; do thou forthwith, and without delay of any kind, manifest thy self in this Black Seal of infernal power and make manifest that which I desire in this world of mortal flesh and blood.

"Be thou ruled and governed by me in the Name of the Eternal, Living and True God, HELIOREM. Amen."

THE EVOCATION OF ELIGOR

Eligor is evoked at any hour from sunrise till noon.

"I conjure and constrain thee, O Spirit Eligor, by Him who hath condemned thee to the lower regions of Hell, by His omnipotent Name TETRAGRAMMATON EL CHAI, and by the Names ELOY, ADONAI, ELOY, AGLA and ZEBAOOTH, do I command of thee to come and fulfil all my desires which seem good unto me.

"Be thou ruled and governed by me in the Name of the Eternal, Living and True God, HELIOREM. Amen."

THE EVOCATION OF FLAUROS

Hour of Evocation: Any hour from sunrise till noon.

"Come, Flauros! Come, Flauros! Come, Flauros! I conjure and command thee, O Great and Powerful Spirit Flauros, by the power and virtue of the Names of BARALAMENSIS, BALDACHIENSIS, PAUMACHIE and APOLORESEDES, do I evoke thee and command thee to fulfil my will, and obey my wishes. Come, therefore, and bless this Seal with thy own infernal powers.

"Be thou ruled and governed by me in the Name of the Eternal, Living and True God, HELIOREM. Amen."

THE EVOCATION OF FOCALOR

Focalor is evoked at any hour from sunrise till noon.

"I conjure thee, O Most Noble Spirit FOCALOR, by the particular and True Name of God to whom thou owest thine obedience; by the Sovereign Creator of all things; by the Names TETRAGRAMMATON, ANEXHEXETON and PRIMEMATUM, and by the power and virtue of all the Archangels, do I summon and command thee on this day, and at this hour, to come and make manifest that which I desire.

"Be thou ruled and governed by me in the Name of the Eternal, Living and True God, HELIOREM. Amen."

THE EVOCATION OF FORAS

Foras is evoked at any hour of the day or night. Foras is evoked with the following words-of-power, which should be spoken clearly and with feeling:

"In the Power of the Names JEHOVAH, ADONAI, SHADAI EL CHAI and TETRAGRAMMATON, I summon and evoke thee, O Grand and Noble Spirit Foras, do thou forthwith manifest thy presence in this Black Seal of infernal power, and without deceit or deception of any kind, make manifest that which I desire from thee.

"Be thou ruled and governed by me in the Name of the Eternal, Living and True God, HELIOREM. Amen."

THE EVOCATION OF FORNEUS

Hour of Evocation: Any hour from sunset till sunrise.

"I summon and evoke thee, O Mighty Spirit Forneus, by the most merciful of Gods, EL, Whose power and majesty and virtue has no beginning nor end, and by the power of the Name ANEXHEXETON, do I command thee to bless this Seal, with all the power and virtue that is yours to give. Come, then, Forneus and bring unto me all that I desire.

"Be thou ruled and governed by me in the Name of the Eternal, Living and True God, HELIOREM. Amen."

THE EVOCATION OF FURCAS

Furcas is evoked at any hour from sunrise till noon. Furcas is evoked with the following words-of-power, which should, for the best possible effect, be spoken aloud in a clear and commanding voice:

"I conjure thee, O Grand and Noble Spirit Furcas, by the authority of God the Father Almighty, and by the powers and virtues of the Names ADONAI, JAH, ELOHIM, EL, ELOHE, ZEBOATH, ELION, ESCHERCE, JAH, TETRAGRAMMATON and SADAI: do I command thee, O wicked spirit of Hell, to come forthwith and manifest, in no uncertain manner, that which I desire above all else.

"Be thou ruled and governed by me in the Name of the Eternal, Living and True God, HELIOREM. Amen."

THE EVOCATION OF FURFUR

Furfur is evoked at any hour of the day.

"I call thee, O Spirit Furfur, to come forthwith from wheresoever thee be, to appear in a comely shape, with neither evil nor deception

in thine heart – if a heart thou hast – to bless this, thy own Seal, with thy powers and virtues thee alone possess, with which I may attain that which I desire above all the kingdoms of the earth.

“Be thou ruled and governed by me in the Name of the Eternal, Living and True God, HELIOREM. Amen.”

THE EVOCATION OF GAAP

Gaap is evoked at any hour of the day up to twilight, but only when the sun is in one of the southern signs of the celestial void.

“I summon thee, O Spirit Gaap, by the Name of JOTH, whose name was given to Jacob by an Angel, and he was saved; by the Power and Authority of Satan, do I command and constrain thee to fulfil my will in all things which seem good for me.

“Be thou ruled and governed by me in the Name of the Eternal, Living and True God, HELIOREM. Amen.”

THE EVOCATION OF GAMYGYN

Hour of Evocation: Any hour from sunset to sunrise. Gamygyn is evoked with the following words-of-power, which should, for the best possible effect, be spoken aloud in a firm and commanding voice:

“I summon thee, O Most Noble Spirit Gamygyn, by the Names JETROS, ASTAROTH, PARACLETUS and HAGIOS, do I summon thee forthwith from wheresoever thee may be on the earth or beyond; be it in Heaven or Hell that ye may seek to hide, do I summon, constrain and command thee to appear this night in a good and comely shape, without threat or danger to my body or soul; come, therefore, and bring unto me all that I desire in life.

“Be thou ruled and governed by me in the Name of the Eternal, Living and True God, HELIOREM. Amen.”

THE EVOCATION OF GLASYALABOLAS

Glasyalabolas is evoked at any hour of the day up to the evening twilight.

“I conjure thee, O Mighty and Powerful Spirit Glasyalabolas, by the powers and virtues of the Names ALPHA and OMEGA, which Daniel uttered, and destroyed Bel and the Dragon, do I command thee

to forthwith, and without delay, manifest thyself within this Black Seal of infernal power, and to make manifest that which I desire.

“Be thou ruled and governed by me in the Name of the Eternal, Living and True God, HELIOREM. Amen.”

THE EVOCATION OF GOMORY

Gomory is evoked at any hour from sunrise till noon.

“I conjure and evoke thee, O Grand and Noble Spirit GOMORY, do thou forthwith appear and show thyself unto me, here within this Black Seal of infernal power, without neither harm nor injury to my body or soul; do thou come immediately from wheresoever thee may be, and make manifest that which I desire, being conjured by the particular and true name of the King who rules thee and constrains thee in Hell, do thou come at once and do my bidding.

“Be thou ruled and governed by me in the Name of the Eternal, Living and True God, HELIOREM. Amen.”

THE EVOCATION OF GUSION

Gusion is evoked at any hour from sunrise till noon.

“Come, Gusion! Come, Gusion! Come, Gusion! I conjure and command thee Spirit Gusion, by the power of the Names ELOY, ELOHIM, ELOHE, ZABAOTH, ELION, ESARCHIE, ADONAI, JAH, TETRAGRAMMATON and SADAI EL CHAI, do thou come forthwith; by the power and virtue of the Names ALPHA, ELY, ELOHE, ZABAOTH, ELION, SADAI, and, OMEGA, do thou come without tarrying; come, forthwith, and bless this Seal with all the infernal powers that thou dost possess

“Be thou ruled and governed by me in the Name of the Eternal, Living and True God, HELIOREM. Amen.”

THE EVOCATION OF HAGENTI

Hagenti is evoked at any hour of the day up to the evening twilight.

“I conjure and evoke thee, O Might Spirit Hagenti, who has the power to change all metals into gold; by all the Most Holy Names of the Divinity, by the Sacred Names of the All-Powerful and True God, creator and manifester – without beginning nor end – do I command

thee, O Spirit, to obey me, and to fulfil my will in all things which seem good unto me.

“Be thou ruled and governed by me in the Name of the Eternal, Living and True God, HELIOREM. Amen.”

THE EVOCATION OF HALPAS

Halpas is evoked at any hour of the day or night.

“I call, summon, evoke, conjure and constrain thee, O Mighty Spirit Halpas, by the omnipotence of the true and living God, in the name of the Father, Son, and of the Holy Ghost, do I command thee to come forthwith, and manifest within this Seal, without neither harm nor injury to my body or soul, come forever at my calling, bringing with thee all the joy and happiness of wishes fulfilled and desires manifested.

“Be thou ruled and governed by me in the Name of the Eternal, Living and True God, HELIOREM. Amen.”

THE EVOCATION OF IPOS

Ipos is evoked at any hour of the day. The following words-of-power should, for the best possible effect, be spoken aloud in a clear and commanding tone of voice:

“Harm me not, Ipos! Harm me not, Ipos! Harm me not, Ipos! I conjure thee, O Spirit Ipos, in the Name of Lucifer, by the power of Satan, by the virtues and desires of Astaroth, do I command thee to forthwith come, without inflicting a cruelty of any kind, without harm or injury to my body or soul; I command thee again, to appear within this Black Seal of infernal and material desire. Come and make manifest that which is yours to give.

“Be thou ruled and governed by me in the Name of the Eternal, Living and True God, HELIOREM. Amen.”

THE EVOCATION OF LERAJIE

Lerajie is evoked at any hour from sunset to sunrise.

“I conjure thee, O Powerful and Mighty Spirit Lerajie, by the Lord God, by the eternal God, by the living God, by the true God, do thou come forthwith! I conjure thee again by the Ineffable Names of

the Lord, JAH, ALPHA, ELOY, ELOYM, ON, SADAI, AGLA, EMMANUEL, and, OMEGA, do I conjure thee, O Spirit, to come unto me in a good and comely shape, without deceit, without harm nor injury to my body or soul, and make manifest all that I desire in an ordinary world.

“Be thou ruled and governed by me in the Name of the Eternal, Living and True God, HELIOREM. Amen.”

THE EVOCATION OF MALPAS

Malpas is evoked at any hour of the day up to the evening twilight.

“I evoke thee, O Spirit Malpas, by the power and virtue of Grand ADONAI, ELOIM, ARIEL and JEHOVAH, in the honour and majesty of the Nameless One who is superior to all things, both celestial and infernal, do I evoke, summon, command and constrain thee Spirit, to appear forthwith within the Seal and room; obeying my every thought, and my every whim.

“Be thou ruled and governed by me in the Name of the Eternal, Living and True God, HELIOREM. Amen.”

THE EVOCATION OF MARBAS

Marbas is evoked at any hour of the day up to the evening twilight.

“I conjure thee, O Mighty and Powerful Spirit Marbas, who hath dominion over all physical diseases; by the Name EMMANUEL, which the three children, Shadrach, Meshach and Abednego, chanted in the midst of the fiery furnace, and instantly, in the wisdom of the Lord JEHOVAH, were delivered; by the Name ALPHA and OMEGA, which Daniel uttered, and destroyed Bel and the Dragon, do I call thee, to hear and obey my commands.

“Be thou ruled and governed by me in the Name of the Eternal, Living and True God, HELIOREM. Amen.”

THE EVOCATION OF MARCHOSIAS

Marchosias is evoked at any hour from sunset to sunrise.

“I command and constrain thee, O Spirit Marchosias, by the Most Holy Names of God, SABAOOTH, ADONAI, JEHOVAH, JAH, TETRAGRAMMATON, SADAI, EMMANUEL, ALPHA, OMEGA,

and, AGLA: do I summon and command thee to come forth from the Bottomless Pit, to hear and obey my every command.

“Be thou ruled and governed by me in the Name of the Eternal, Living and True God, HELIOREM. Amen.”

THE EVOCATION OF MORAX

Morax is evoked at any hour of the day.

“I evoke, conjure and command thee, O Most Noble and Majestic Spirit Morax, by the name JEHOVAH; by the Seal of BASADETHERA and by the power and virtue of the Seven Sacred Names of ADONAI, PRERAI, TETRAGRAMMATON, ANEXHEXETON, INESSENSATOAL, PATHUMATON and ITEMON: do thou forthwith, and without delay, manifest thyself in this Black Seal of infernal powers and make manifest that which I desire above all else.

“Be thou ruled and governed by me in the Name of the Eternal, Living and True God, HELIOREM. Amen.”

THE EVOCATION OF MURMUR

Murmur is evoked at any hour of the day.

“I conjure and constrain thee, O Spirit Murmur, by Him who hath condemned thee to the lower regions of Hell, by His omnipotent Name TETRAGRAMMATON EL CHAI, and by the Names ELOY, ADONAI, AGLA and ZEBAOOTH, do I command of thee to come forth and fulfil all my desires which seem good unto me.

“Be thou ruled and governed by me in the Name of the Eternal, Living and True God, HELIOREM. Amen.”

THE EVOCATION OF NABERIUS

Hour of Evocation: Any hour from sunset to sunrise.

“Come, Naberius! Come, Naberius! Come, Naberius! conjure and command thee, O Great and Powerful Spirit Naberius, by the power and virtue of the Holy Names BARALAMENSIS, BALDACHIENSIS, PAUMACHIE and APOLORESEDES, do I evoke and command thee to fulfil my will, and to obey my wishes. Come, therefore, and bless this, thy own Seal, with the infernal powers vested in thee.

“Be thou ruled and governed by me in the Name of the Eternal, Living and True God, HELIOREM. Amen.”

THE EVOCATION OF ORIAS

Orias is evoked at any hour from sunset to sunrise.

“In the Power of the Name ADONAI, ELOHIM, JAH, and, SADAI EL CHAI, I do evoke and command thee, O Great and Regal Spirit Orias, to manifest in no uncertain manner, thy presence, powers and virtues within this, thy own Black Seal, and, by the fury of the everlasting Fire, manifest that which I desire of thee.

“Be thou ruled and governed by me in the Name of the Eternal, Living and True God, HELIOREM. Amen.”

THE EVOCATION OF OROBAS

Orobas is evoked at any hour of the day.

“I evoke, conjure and command thee, O Most Noble and Regal Spirit Orobas, by the Name JEHOVAH, which Adam did hear and spoke; by the Royal Seal of BASDATHEA, by this Name PRIMEMATUM, which Moses spoke, and the earth opened up and swallowed Corah, Dathan and Abriam; do thou forthwith manifest thy power in this Black Seal, and manifest that which I desire.

“Be thou ruled and governed by me in the Name of the Eternal, Living and True God, HELIOREM. Amen.”

THE EVOCATION OF OSE

Ose is evoked at any hour of the day up to the evening twilight.

“I conjure and constrain thee, O Most Noble Spirit Ose, by these Seven Names with which Solomon did bound thee and thy fellow devils in the brass vessel and freed mankind from thy evil torment; being, ADONAI, PRERAI, TETRAGRAMMATON, ANEXHEXETON, INESSENSATOAL, PATHUMATON and ITEMON; do thou forthwith manifest in the Black Seal of thy infernal powers, and fulfil my will in all things.

“Be thou ruled and governed by me in the Name of the Eternal, Living and True God, HELIOREM. Amen.”

THE EVOCATION OF PAIMON

Hour of Evocation: Paimon is evoked at any hour from 9 a.m. till noon.

“I conjure thee, O Mighty and Noble Spirit Paimon, by Him to Whom all of the creatures are obedient, by this ineffable Name, TETRAGRAMMATON JEHOVAH, by which even the elements are overthrown, the air is shaken, the sea turns back, the all consuming fire is generated, the earth moves, and all the hosts of all things celestial, of things terrestrial, of things infernal, do tremble and are of confusion; come into this Seal, come I command thee from wheresoever thee may be, and make manifest all those desires within me which seem good unto me.

“Be thou ruled and governed by me in the Name of the Eternal, Living and True God, HELIOREM. Amen.”

THE EVOCATION OF PHOENIX

Phoenix is evoked at any hour from sunset to sunrise.

“I conjure and adjure thee, O Grand and Noble Spirit Phoenix, who arose from the ashes, by the particular and True Name of God to whom thou owest thine obedience; by the Name of your King who rules over thee, do thou now come forthwith into the Black Seal; come in and so doing, fulfil each and every one of those desires which are within an area of influence governed, ruled, and controlled by thee and the devils with thee in Hell. Come therefore in the Names of ADONAI and ZEBOATH; come thee unto me this night.

“Be thou ruled and governed by me in the Name of the Eternal, Living and True God, HELIOREM. Amen.”

THE EVOCATION OF PROCEL

Hour of Evocation: Any hour from sunrise till noon.

“I conjure thee, O Spirit Procel, by all the most noble, glorious and efficacious Names of the Great and Incomparable Lord the God of Hosts; come quick, and without delay of any kind, from whatsoever part of Heaven or Hell that you are in at this time; come into this Black Seal, and make manifest that which I desire.

“Be thou ruled and governed by me in the Name of the Eternal, Living and True God, HELIOREM. Amen.”

THE EVOCATION OF PURSON

Hour of Evocation: Any hour from 9 a.m. till noon.

“I conjure thee, O Most Powerful and Mighty Spirit Purson, and do command thee by the most Holy Names of ELOY, ADONAI, ELOY, AGLA, and, ZEBAOOTH, which thee must obey; by the four beasts before the Throne, having eyes before and behind; by the fire which is about the Throne, by the Holy Angels of Heaven, and by the Mighty Wisdom of God, to bless this Seal with thy own infernal & demonic powers, and to make manifest that which is within thy area of powers to do so.

“Be thou ruled and governed by me in the Name of the Eternal, Living and True God, HELIOREM. Amen.”

THE EVOCATION OF RAUM

Raum is evoked at any hour of the day.

“I conjure, evoke and command thee, O Spirit Raum, by all the names with which thee can be summoned and constrained. Come then by the Holy and Grand Names EHEIEH, IOD, TETRAGRAMMATON ELOHIM, EL, ELOHIM GIBOR, ELOAH VADAATH, EL ADONAI TZABAOOTH, ELOHIM TZABAOOTH, SHADAI and all the Holy Names of all the Archangels of the True and Living God; do I command thee to come into this Seal, and to manifest every desire asked of thee.

“Be thou ruled and governed by me in the Name of the Eternal, Living and True God, HELIOREM. Amen.”

THE EVOCATION OF RONOBE

Ronobe is evoked at any hour from sunset to sunrise.

“I conjure thee, O Mighty Spirit Ronobe, by the True and Living God, by the true God, by the holy God, Who spoke and all was made, Who commanded – and all things were created out of nothingness. I conjure and command thee by the three Secret, Powerful and Holy Names AGLA, ON, and, TETRAGRAMMATON by the Name ADONAI, which Moses named, and there came up locusts all over the land of Egypt and devoured what the hail had left; come, therefore and make manifest my desires in no uncertain manner.

"Be thou ruled and governed by me in the Name of the Eternal, Living and True God, HELIOREM. Amen."

THE EVOCATION OF SABNACK

Sabnack is evoked at any hour from sunset to sunrise.

"I call thee, O Great and Powerful Spirit Sabnack, in the Name and by the power and dignity of the Omnipotent and Immortal Lord God of Hosts, JEHOVAH TETRAGRAMMATON, sole Creator of Heaven, Earth and Hell, and all things which swim in the sea, which walk upon the earth, which fly through the skies, do I call thee to come forth from the Bottomless Pit, and make thy presence and authority known by manifesting all the secret desires held captive within my beating heart.

"Be thou ruled and governed by me in the Name of the Eternal, Living and True God, HELIOREM. Amen."

THE EVOCATION OF SALEOS

Hour of Evocation: Any hour from sunrise to noon.

"Come, Saleos! Come, Saleos! Come, Saleos! I conjure and adjure thee, O wicked Spirit Saleos, by the words and virtues of God, by the powerful God unto Whom all the spirits of Heaven and Hell are submitted, I conjure thee again, in the name of the Father, of the Son, and of the Holy Ghost; do I command thee by Him Who shall appraise the worthiness of the living and of the dead, unto Whom all is honour, dignity, and everlasting glory. Come in a good and pleasing shape, without harm or injury to my body or soul, come and obey my will in all things which seem good unto me.

"Be thou ruled and governed by me in the Name of the Eternal, Living and True God, HELIOREM. Amen."

THE EVOCATION OF SEERE

Seere is evoked at any hour of the day.

"I conjure thee, O Spirit Seere, in the Name of Lucifer, in the Name of Beelzebub, in the Name of Mighty Astaroth, and in the name of all the other evil spirits, to make haste and imbue this Black Seal with thy own infernal powers, virtues, and authority. Come, then, in the

Name of Satan, and in the names of all your demonic brothers; come at once, and fulfil my wish and desire.

"Be thou ruled and governed by me in the Name of the Eternal, Living and True God, HELIOREM. Amen."

THE EVOCATION OF SHAX

Shax is evoked at any hour from sunset to sunrise.

"I conjure and command thee, O Most Noble Spirit Shax, by the Name of JOTH, which Jacob learned from the Angel on the night of his wrestling and was delivered from the hands of his brother Esau; by the Name of the God AGLA, which Lot heard and was saved with his family; by the Name and Glory of ANEXHEXETON, which Aaron spake and was made wise; do I command – by the power and virtue of TETRAGRAMMATON JEHOVAH – and adjure thee evil spirit, to fulfil my will in all things which seem good unto me.

"Be thou ruled and governed by me in the Name of the Eternal, Living and True God, HELIOREM. Amen."

THE EVOCATION OF SOLAS

Solas is evoked at any hour of the day.

"I conjure, evoke, adjure, command and constrain thee, O Mighty and Noble Spirit Solas, by the Most High Names of God, HAIN, LON, HIEAY, SABAOOTH, YAH, HELIM, RADISHA, LEDIEHA, ADONAI, JEHOVAH, TETRAGRAMMATON, SADAI, MESSIAS, EL CHAI, AGIOS, ISCHYROS, EMMANUEL, and, AGLA, do I exhort and call thee forth, I command and constrain thee, here into this Seal; do thou forthwith, without delay of any kind, come unto me and make manifest that which I desire.

"Be thou ruled and governed by me in the Name of the Eternal, Living and True God, HELIOREM. Amen."

THE EVOCATION OF SYTRY

Sytry is evoked at any hour of the day.

"I conjure thee, O Perverted Spirit Sytry, who has the power to inflame women with lustful and depraved desires, by Him Who made you, and all your fellow spirits of lust and depravity, by the power

and dignity of the Name TETRAGRAMMATON, do I summon and command thee, at this hour, and on this day, to come forth from wheresoever thee may be in the lowest depths of the world in which thee reside, and to grant me every lustful and depraved desire in this world of flesh and blood.

“Be thou ruled and governed by me in the Name of the Eternal, Living and True God, HELIOREM. Amen.”

THE EVOCATION OF VALAC

Valac is evoked at any hour of the day up to the evening twilight.

“I summon thee, O Spirit Valac, to come and enter into this Black Seal of infernal power, by the ineffable Names JEHOVAH, ADONAI, ELOHE, ELION, SADAI, and, JAH do I conjure, evoke, summon and command thee into submitting to all my earthly desires. By the everlasting goodness of God when He created man, do thou now come forth from wheresoever thee may be in Heaven or Hell, and, in no uncertain manner, obey that which is commanded of thee.

“Be thou ruled and governed by me in the Name of the Eternal, Living and True God, HELIOREM. Amen.”

THE EVOCATION OF VALEFOR

Hour of Evocation: Any hour from sunrise till noon.

“O thou great and powerful Spirit Valefor, I invoke and command thee by the power of the Supreme Being, the everlasting Lord, that God Who created thee in the space of six days; by EYE, by SARAY, by the virtue of the Name PRIMEMATUM, which commands the whole host of Heaven; do I conjure thee, O Spirit Valefor to appear forthwith and fulfil my desire in a most suitable manner.

“Be thou ruled and governed by me in the Name of the Eternal, Living and True God, HELIOREM. Amen.”

THE EVOCATION OF VAPULA

Vapula is evoked at any hour from sunrise till noon.

“I conjure thee, O Spirit Vapula, and command thee, by the Most Holy Names of the True God, ELOY, ADONAI, AGLA, and, TETRAGRAMMATON. I command you by all the Kingdoms of God Whose

Name is JEHOVAH, to come without evil intent and without delay, to obey me in all my commands, without neither harm or injury to my body or soul. Come, Vapula, and make manifest my desire.

“Be thou ruled and governed by me in the Name of the Eternal, Living and True God, HELIOREM. Amen.”

THE EVOCATION OF VASSAGO

Vassago is evoked at any hour of the day.

“I call thee, O Mighty Spirit Vassago, who hath the power to reveal those things which are hidden from the eyes of man, by the Great and Living God of Gods, the Sovereign Creator of all things, to come into this Black Seal, and make it an instrument through which may flow thy infernal powers. I conjure, evoke and call thee again by the powers and virtues of these Most Holy Names EHIEH, IOD, TETRAGRAMMATON, and, SHADAI EL CHAI, come unto me, O Spirit, and do my bidding in all things which seem good unto me.

“Be thou ruled and governed by me in the Name of the Eternal, Living and True God, HELIOREM. Amen.”

THE EVOCATION OF VEPAR

Hour of Evocation: Any hour from sunrise till noon.

“I evoke and conjure thee, O Spirit Vepar, and, fortified with the power of the Supreme Majesty, I strongly command thee evil spirit by the Names of BARALAMENSIS, BALDACHIENSIS, PAUMACHIE, APOLORESEDES and the most potent of princes GENIO, LIACHIDE, Ministers of the Tartean Seat, chief princes known by the Mighty APOLOGIA of the ninth region of Hell, do I evoke and command by the power and virtue of JEHOVAH TETRAGRAMMATON, that thee obey my wishes and desires, now and forever more.

“Be thou ruled and governed by me in the Name of the Eternal, Living and True God, HELIOREM. Amen.”

THE EVOCATION OF VINE

Hour of Evocation: Any hour from 9 a.m. till noon. Vine is evoked aloud in a clear and commanding tone of voice:

“I conjure thee, O Mighty and Powerful Spirit Vine, by the authority

of God the Father Almighty, by the powers and virtues of Heaven, Hell and the celestial void, by the powers and virtues of all the Angels, do I call and command thee, O Mighty Spirit, to come forth from the blackest pit and bless this Seal with thy own infernal powers.

“Be thou ruled and governed by me in the Name of the Eternal, Living and True God, HELIOREM. Amen.”

THE EVOCATION OF VUAL

Vual is evoked at any hour from sunrise till noon.

“I command and conjure thee, O Spirit Vual, by the Name ZEAOTH, which Moses named, and by the Name ESCERCHIE ARISTON, which Moses also named, and the rivers and waters, of all the lands of Egypt which were turned into blood; by the Name ADONAI, which he of Egypt named, do I command and summon thee forthwith from wheresoever thee is in the world, to come and make manifest that which I desire.

“Be thou ruled and governed by me in the Name of the Eternal, Living and True God, HELIOREM. Amen.”

THE EVOCATION OF ZAGAN

Hour of Evocation: Any hour from 9 a.m. till noon.

“I conjure and adjure thee, O Mighty and Powerful Spirit Zagan, by the Name ELION, on which Moses called, and there fell a great hail, such as was unknown since Creation of the Earth; by the Name HAGIOS; by the Sacred Seal of ADONAI, by those others, which are JETROS, ATHERNOROS and PARACLETUS do I summon thee, by the honour and glory of Mighty JEHOVAH, to make this Seal a symbol of thine own infernal powers, and I also command of thee to bring unto me all things in no uncertain manner.

“Be thou ruled and governed by me in the Name of the Eternal, Living and True God, HELIOREM. Amen.”

THE EVOCATION OF ZEPER

Zeper is evoked at any hour from sunrise till noon.

“I conjure thee, O Mighty Spirit Zeper, by the powers and virtues of the Names ADONAI, ELOHIM, JAH, EL, ELOHE, ZEAOTH,

ELION, ESCHERCE, SADAI, JEHOVAH EL CHAI, and, TETRAMMATON: do thou forthwith come and make thine presence known unto me, in no uncertain manner, by making manifest what is desired by me.

“Be thou ruled and governed by me in the Name of the Eternal, Living and True God, HELIOREM. Amen.”

HOW TO DISMISS THE EVOKED SPIRIT

Having evoked the spirit-force symbolised by the appropriate Black Seal; and having both charged and consecrated the said seal, the spirit must, and this is very important for all our sakes, be dismissed from this world. A spirit evoked and left to wander the world will only cause unnecessary suffering and hardship for both the evoking magician and those innocent parties who may come – at some time in their lives – into contact with the said spirit. Evoked spirits – both good and bad by nature – are the cause of much of the world’s problems.

The evoked spirit-force is dismissed in the following manner:

“O Spirit (*name of spirit*), because thou hast come at my calling and obeyed my commands, I do hereby dismiss thee from this world, without injury to man, woman, child or beast. Begone, I command, and be thou ready and willing to come again at my calling, whensoever that may be, providing it is performed and executed under the Sacred Rites of Magick. I command thee again to leave this place at once. Begone! Begone! Begone! Amen.”

Under no circumstances must you dismiss the image of the halo of bright and comforting light – generated by the King Solomon Protection Chant – until you, and those who may be with you, are certain that the evoked spirit-force has in fact been driven from the surrounding atmosphere.

SOME FINAL WORDS

Just like those ancient magickal adepts of long, long ago, you could be on the verge of improving every aspect of your mortal life; or even certain special areas of your life in need of extra attention, by creating,

RESEARCH ... **CONCLUSIONS** ... **RECOMMENDATIONS** ...

RESEARCH AND CONCLUSIONS

The research was conducted in three phases. The first phase involved a literature review of existing studies on the topic. The second phase involved a series of experiments designed to test the hypotheses. The third phase involved a detailed analysis of the data collected during the experiments.

The results of the experiments are presented in the following tables. Table 1 shows the mean values for each variable. Table 2 shows the standard deviations for each variable. Table 3 shows the correlations between the variables.

The findings of this study indicate that there is a significant relationship between the variables studied. The results suggest that the proposed model is valid and can be used to predict the outcomes of the study. The study has several limitations, including a small sample size and a lack of control over some external factors.

Future research should focus on addressing these limitations and exploring the relationship between the variables in greater detail. The study has provided valuable insights into the topic and has contributed to the existing body of knowledge.

The study was supported by the National Science Foundation. The authors would like to thank the reviewers for their constructive comments. The authors also would like to thank the participants for their participation in the study.

REFERENCES

- Smith, J. (2010). *Journal of Applied Psychology*, 95(3), 456-470.
- Johnson, L. (2011). *Journal of Experimental Psychology*, 142(2), 123-135.
- Williams, K. (2012). *Journal of Personality and Social Psychology*, 103(1), 78-90.

APPENDIX A

Table A1: Mean values for each variable. Table A2: Standard deviations for each variable. Table A3: Correlations between the variables.

APPENDIX B

Table B1: Description of the experimental procedure. Table B2: List of the variables measured.